

THE ANDREE PUTMAN COLLECTION

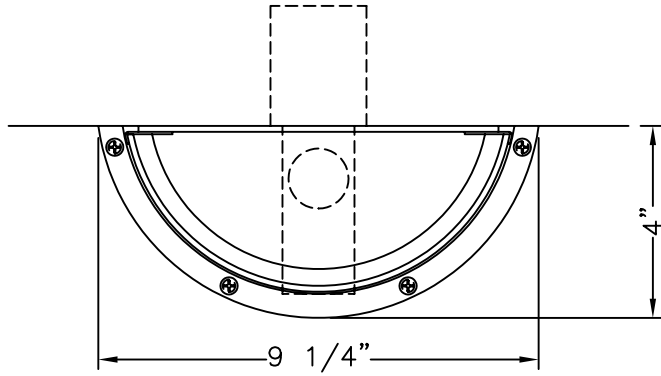

LINE OF FINISHED WALL

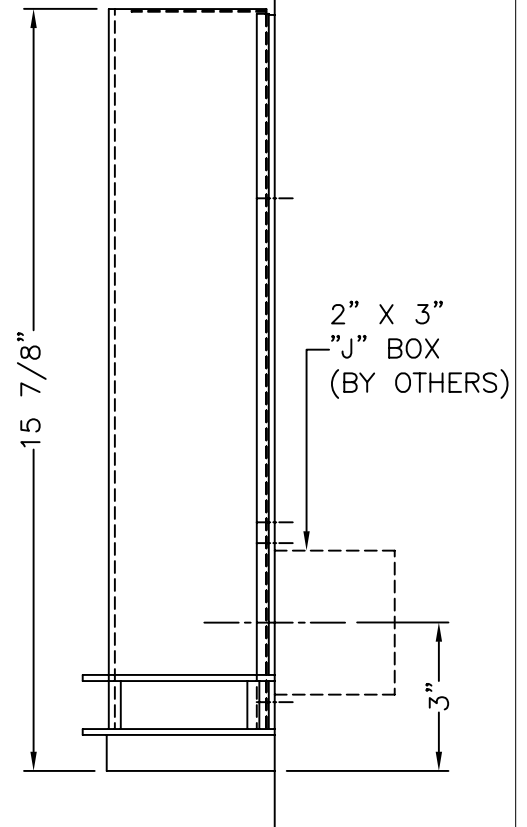
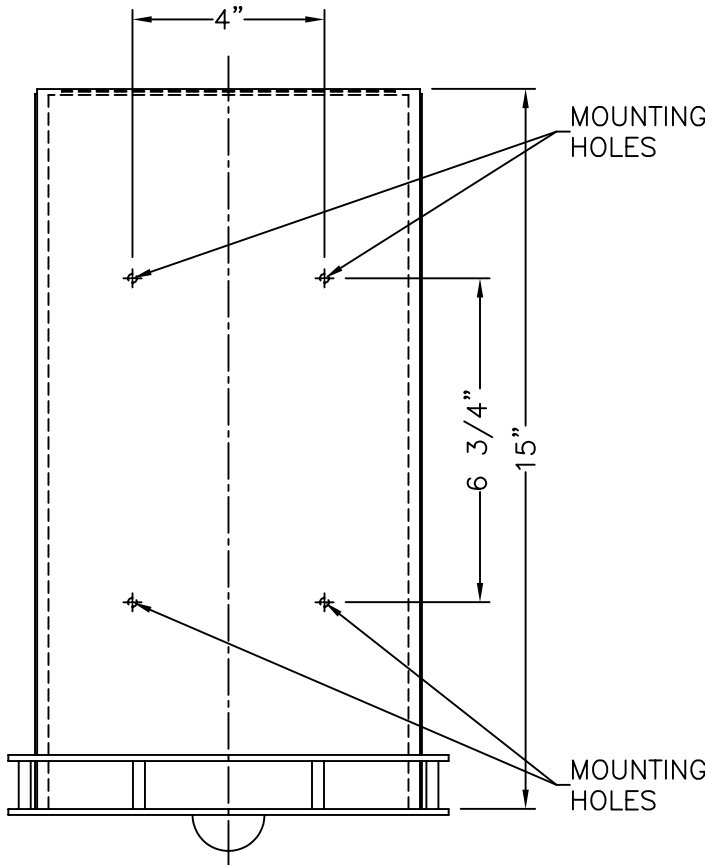

© BALDINGER ARCHITECTURAL LIGHTING, INC.

FIXTURE WEIGHT: 15 LBS

PURCHASER: _____ DATE: 12/22/00

JOB NAME: _____ TYPE: _____ QUANTITY: _____

METAL FINISHES

- ANTIQUE BRASS
- SATIN BRASS
- POLISHED BRASS
- POLISHED CHROME
- POLISHED NICKEL
- SATIN NICKEL
- OTHER _____

DIFFUSERS

- WHITE FAUX ALABASTER
- BEIGE FAUX ALABASTER
- BEIGE ALABASTER
- WHITE ALABASTER
- CLEAR GLASS FROSTED
- WHITE OPAL GLASS
- OTHER _____

LAMPING

- (1) 75W T-10 (120V only)
- (1) FT24W (see below)
- OTHER _____

VOLTAGE

- 120V OTHER _____

JOB #:

BALDINGER

BALDINGER ARCHITECTURAL LIGHTING INC
19-02 STEINWAY STREET, ASTORIA, NEW YORK 11105
TEL. (718) 204-5700 FAX. (718) 721-4986

BERTILLE 15"
AP27632/15