



---

# Kick Solutions Specification Guide

## Availability

**Electronic price list updated** with release 200.I (U.S.) and 156.I (Canada), dated October 16, 2023.

All specifications subject to change without notice. Reference the electronic catalog/Hedberg for current pricing.

Transitional products in this specification guide are **maintained for existing customers only** and are likely to be phased out over time. These products are indicated with a . Products that are scheduled to be culled are indicated with an , followed by the last order entry date.

## Surface Materials

**The surface materials team** has announced the launch of the Finish Library, found at [www.steelcase.com/finishlibrary/](http://www.steelcase.com/finishlibrary/).

► For a list of all trademarks, refer to the last page of this specification guide. © 2023 Steelcase Inc.

## Working With This Specification Guide

Ten Tips: How to Get the Most Out of This Book	2
Additional Resources	4

## Kick Solutions

Understanding	5
Specifying	173

## Lighting

Understanding	335
Specifying	351

## Surface Materials

Resources	359
-----------	-----



### For Canadian Pricing

Canadian factor can be found at [www.steelcase.com/CADpricing/](http://www.steelcase.com/CADpricing/). Calculate in the following order to avoid rounding errors:

- Multiply the base price and each option by the Canadian factor.
- Round each to the nearest dollar.
- Add base and options for total list price.

# Ten Tips: How to Get the Most Out of This Book

## Tip 1

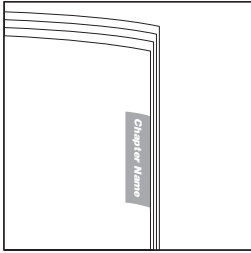

**Watch** the tabs on the right-hand edges of the pages. They'll always indicate which chapter you are in.

## Tip 2

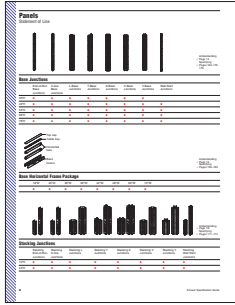

**Use the Statement of Line pages** for an overview of the available components, their sizes, and page references for additional information. Each *Understanding* chapter includes a statement of line after the table of contents.

## Tip 3



**Find cross references** by looking for page numbers flagged with an arrow.

## Tip 4

**Study the product detail pages** in the *Understanding* section to learn everything an expert knows about specific products. Each product detail page in this section contains the following features, where applicable:

- Product Drawing
- Actual Dimensions
- Product Details
- Connections
- Wiring and Cabling
- Surface Materials
- Application Topics

**Product Drawing** shows you what the product looks like and points out important features.

**Product Details** gives specific information on the product and how it is used.

**Connections** describes how the product is assembled or how it attaches to another product.

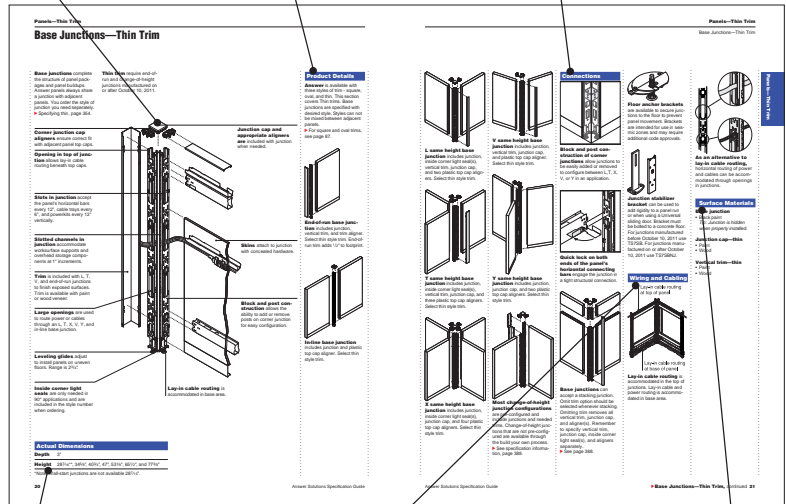

**Actual Dimensions** table lists the dimensions of the product.

**Wiring and Cabling** details the power and cable-management and cable routing capabilities of the product.

**Surface Materials** lists what material is used for each part of the product.

**Tip 5**

**Refer to the specifying pages** for all the information needed to order a product. Each product specifying page contains a variety of elements to help you complete a specification:

- Product Drawing
- Standard Includes
- Required to Specify
- Options
- Related Products
- Specification Information
  - Dimensions
  - Style Number
  - Price

**Product Drawing** shows you what the product looks like.

**Standard Includes** (under the red or dark grey band) provides a list of what comes standard with the product.

**Required to Specify** (under the red or dark grey band) itemizes the information that you must provide to order the standard product and the preferred sequence for specification.

**Specification Information** (under the teal or light grey band) provides product dimensions, style numbers, and prices for the standard product and any surface material choices that are available.

The image shows two pages from a product specification guide. The left page is titled 'Base Horizontal Frame Packages—Thin Trim' and the right page is titled 'Panel—Thin Trim'. Both pages have a red band at the top for 'Standard Includes' and 'Required to Specify', a black band for 'Options', and a teal band for 'Specification Information'. Callouts from the text on the left point to these sections on the pages. The 'Options' section lists various choices like 'Finish' and 'Glass' with their respective prices. The 'Specification Information' section includes a table with columns for 'Width', 'Style', 'Material', 'Price', and 'Option'.

**Options** (under the black band) lists all the options that apply to the product, their price, and what is required to specify.

**Related Products** provide specification information for products that are directly related.

**Tip 6**

**Required to Specify**

Specify with *Customiz Stain*

**Italic typeface** on specifying pages usually identifies wording that you should use in your order.

**Tip 7**

**To determine** how many skins are needed to complete a panel, consult the table at the right.

*Tip: Remember to order skins for both sides of the panel buildup.*

**Watch for tips** throughout the text that give you explanations and helpful instructions.

**Tip 8**

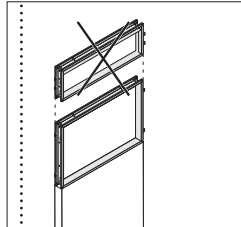

**Learn what you cannot do** by looking for drawings crossed out with an "X."

**Tip 9**

**Use the surface materials listings** in the Surface Materials section of this book to find surface material color numbers.

**Tip 10**

Style Number	Page
TS7042BL	131
TS7042S	130
TS7048BL	131
TS7048S	130
TS7060BL	131
TS7060S	130
TS7072BL	131

**Refer to the style number index** when you need to find the page that has more details about the product.

# Additional Resources

**Kick** is supported with an array of informational materials, tools, and software to help you plan and install efficiently.

**Product brochures and planning tools** can be ordered through your Steelcase area office by calling 1.800.784.0358 or through the Marketing Resources web site at [village.steelcase.com](http://village.steelcase.com).

## Printed Materials

### Kick Systems Furniture Brochure

Form Number 06-0001593

### Kick Thought Starters

Form Number T3232

**Storage Specification Guide** contains storage that attaches to Kick.

### Quick Ship Guide

This handbook describes all Steelcase and Coalesse products that are available for Rapid2 (ships in 2 days), Rapid5 (ships in 5-7 days), or Coalesse Rapid10 (ships in 10 days).

### U-Free Product Brochure

This 8-page brochure introduces the U-Free family of freestanding solutions, including traditional and contemporary desk applications, tables and storage. Includes an abbreviated statement of line.

Form number 08-0000159

### Surface Materials Reference Manual

This publication provides:

- An explanation of the surface materials program
- "Available on" matrices
- Vertical surface fabric and seating upholstery selection listing
- Technical data for surface materials
- Surface material care and cleaning instructions

## Computer Tools

### Electronic Catalog

Accurate sales quotations and purchase orders for Kick products are created with specification software that uses Kick Electronic Catalog data. Use the data to specify and price style numbers and options for every Kick product. The data is updated bimonthly by Steelcase and provided to software programs like the Hedberg Business System, 20-20 CAP Studio.

### Furniture Symbol Graphic Data

Steelcase creates 2D and 3D furniture symbols (with attributes) for planning and initially specifying Steelcase products. This data is incorporated into several add-on software packages that work in either a Microstation or an AutoCAD drafting environment.

For more information about these and other software tools to help you plan effective work environments, please email [fsl@steelcase.com](mailto:fsl@steelcase.com)

### Digital Publications

You can access these digital publications at [www.steelcase.com](http://www.steelcase.com) or [village.steelcase.com](http://village.steelcase.com).

## Kick Product Training

Basic training for the Kick systems products is available as part of the Building Product Muscle (BPM) curriculum on the Steelcase University Web site at [village.steelcase.com](http://village.steelcase.com).

The Kick BPM is an interactive, web-based course, filled with photos, detailed positioning, statement of line, features/advantage, application, and specification information, as well as practice exercises designed to build salespeople's knowledge of the Kick system. The course also contains printable job aids to provide ongoing performance support. The Kick BPM is course SAL188.

## Support

### Steelcase Capabilities

Steelcase products are distributed, installed, and serviced through a network of more than 600 dealers worldwide. Steelcase is also represented with offices and corporate showrooms in 26 U.S. cities, 4 Canadian cities, and in France, Germany, Great Britain, and Japan. Every Steelcase product meets our exceptionally high standards of quality and durability and comes with the Steelcase assurance of excellence in service.

**For ordering or product assistance**, please call your local dealer, the Steelcase Solutions Resource Team, or the Steelcase Solutions Fulfillment Team at 1.800.STEELCASE (1.800.887.6786).

Call the Steelcase Solutions Fulfillment Team if you have submitted an order to Steelcase and you need to speak to your Solutions Fulfillment Team Representative about the order. Also call if you have any post-shipment quality concerns or service parts questions.

For warranty information, please go to <http://www.steelcase.com/warranty/>.

Outside the U.S.A., Canada, Mexico, Puerto Rico, and the U.S. Virgin Islands, call 1.616.247.2500.

## Sustainability

At Steelcase, we believe business can be a force for good. We create long-lasting products that are better for people and better for the planet. Our products and operations use life cycle thinking to meet our commitment to reducing climate change. This commitment is reinforced by practices such as designing to minimize global warming and other life cycle impacts, ensuring material health, and enabling end-of-use strategies.

To learn more at a corporate level, visit: <https://www.steelcase.com/discover/steelcase/esg-overview/environmental/>

Product Environmental Profiles, which provide key environmental attributes such as recycled content, embodied carbon and recyclability, as well as product certifications can be found by searching for Steelcase at [Origin.build](http://Origin.build).

---

# Understanding Kick Solutions

<b>Panels</b>	<b>7</b>
<b>Wiring and Cabling</b>	<b>33</b>
<b>TS Series Worksurfaces and Supports</b>	<b>55</b>
<b>Universal Systems Worksurfaces and Supports</b>	<b>71</b>
<b>Counterweights</b>	<b>109</b>
<b>TS Series Storage Products</b>	<b>119</b>
<b>Universal Steel Storage Products</b>	<b>135</b>



---

# Understanding Panels



<b>Statement of Line</b>	<b>8</b>
	
<b>Monolithic Panels</b>	<b>10</b>
<b>Segmented Panels and Stacker Options</b>	<b>12</b>
<b>Panel Stackers</b>	<b>14</b>
<b>Panel Connectors</b>	<b>16</b>
<b>Off-Module Connections</b>	<b>18</b>
<b>Panel Trim</b>	<b>20</b>
<b>Sliding Panel Door</b>	<b>24</b>
<b>Stability Guidelines</b>	<b>26</b>

# Statement of Line

## Panels

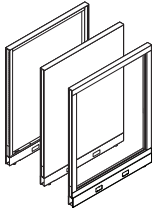

Understanding  
 ▶ Page 10  
 Specifying  
 ▶ Page 176

### Monolithic Panels

	24"W	30"W	36"W	42"W	48"W	60"W
42"H	●	●	●	●	●	●
48"H	●	●	●	●	●	●
54"H	●	●	●	●	●	●
66"H	●	●	●	●	●	●

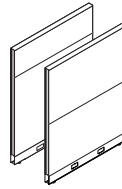

Understanding  
 ▶ Page 12  
 Specifying  
 ▶ Pages 178

### Segmented Panels

	24"W	30"W	36"W	42"W	48"W	60"W
42"H	●	●	●	●	●	●
48"H	●	●	●	●	●	●
54"H	●	●	●	●	●	●
66"H	●	●	●	●	●	●

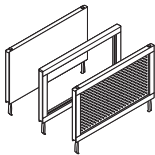

Understanding  
 ▶ Page 14  
 Specifying  
 ▶ Page 184

### Panel Stackers

	24"W	30"W	36"W	42"W	48"W	60"W	72"W
12"H	●	●	●	●	●	●	●
18"H	●	●	●	●	●	●	●
24"H	●	●	●	●	●	●	●



Understanding  
 ▶ Page 20  
 Specifying  
 ▶ Page 186

### Vertical End-of-Run Trim

	42"H	48"H	54"H	60"H	66"H	72"H	78"H
Standard	●	●	●	●	●	●	●



Understanding  
 ▶ Page 20  
 Specifying  
 ▶ Page 187

### Change-of-Height Trim

	6"H	12"H	18"H	24"H	36"H
Standard	●	●	●	●	●
High	●	●	●	●	●

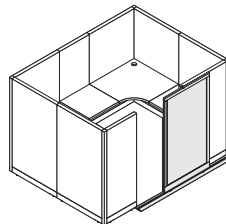

Understanding  
 ▶ Page 24  
 Specifying  
 ▶ Page 193

### Sliding Panel Doors

	66"H	78"H
36"W	●	●
42"W	●	●



# Monolithic Panels

**Panels** are constructed with a rigid, tubular steel frame and are shipped fully assembled. Remember to order trim separately.  
 ▶ Specifying, page 176.

**Wire separator** for the panel base can be ordered through Kick Service Parts to provide a separate, isolated space for routing data and telecommunication cables. It also serves as a second metallic barrier between low-voltage communication wires and 120-volt electricity.

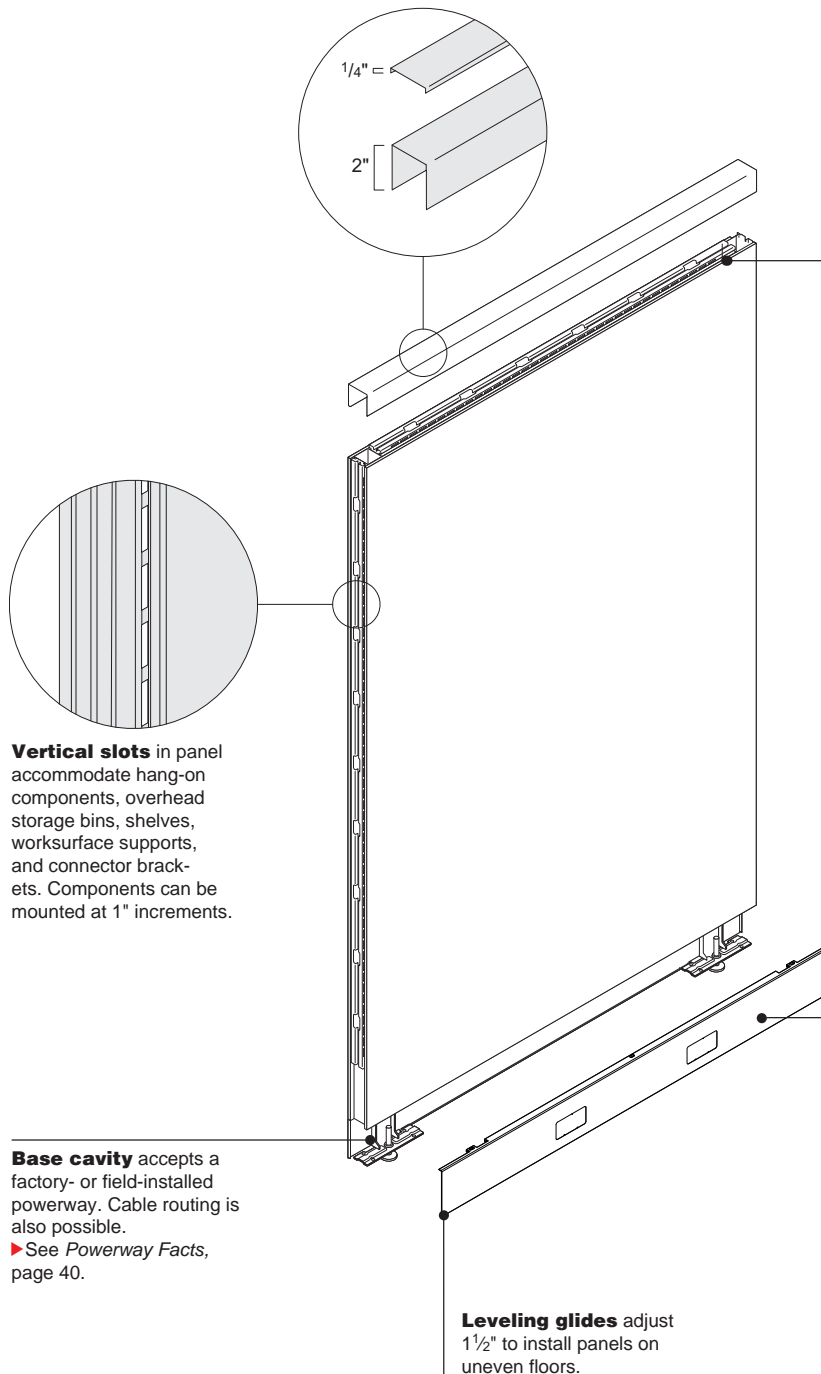

**Steel top caps** are available in two heights—low is standard and high is available as an option. High top cap will accommodate cable routing at the top of the panel.

**Horizontal slots** accommodate off-module connections.

**Vertical slots** in panel accommodate hang-on components, overhead storage bins, shelves, worksurface supports, and connector brackets. Components can be mounted at 1" increments.

**Base cavity** accepts a factory- or field-installed powerway. Cable routing is also possible.  
 ▶ See *Powerway Facts*, page 40.

**Removable base cover** has receptacle knockouts. Base covers have a receptacle opening on the left and right side of the base cover. *Exception: 24"W base covers have a receptacle opening in the center of the base trim.*

**Leveling glides** adjust 1½" to install panels on uneven floors.

## Actual Dimensions

<b>Height</b>	42", 48", 54", or 66"
<b>Width</b>	24", 30", 36", 42", 48", or 60"
<b>Thickness</b>	2"
<b>Base Raceway Height</b>	3 <sup>5</sup> / <sub>8</sub> "
<b>Glides</b>	1½" adjustment

### Product Details

**Kick panels** come in four types.

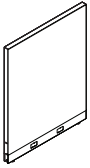

**Tackable acoustical**—skin on each side, covered with vertical surface fabric.

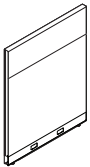

**Segmented**—tackable skins on one or both sides, covered with vertical surface fabric.



**Glass**—single pane of clear, tempered safety glass on panel centerline, surrounded by painted border. Glass panels can accept glass stackers.

### Wiring & Cabling

**Panel frames** have hollow interior to allow routing cables from top cap through to base raceway.

**Kick** is available with an optional high top cap to accommodate additional cable capacity at the top of the panel.

**Chicago electrical code** requires that all electrical connections be hardwired in the field. Order a non-powered panel and have the electrician obtain conduit and receptacles (Leviton 5325) to make the connections in the field.

### Surface Materials

**Base cover, top cap, and border**

- Paint

**Panel surface**

- Fabric
- 6500 Clear Glass

# Segmented Panels and Stacker Options

**Kick** allows a wide variety of panel arrangements to meet specific functional and aesthetic needs. Panels are not dedicated to a specific location and can be used anywhere on the face of the panel. Illustrations show largest sized skin in bottom position.

## Stacking Guidelines

**Stackers** are available in 12"H, 18"H, or 24"H in tackable acoustical or glass.

**Maximum height** is 78".

**Maximum number of tackable acoustical stackers** is three.

**Maximum number of glass stackers** is one.

**Any height base panel** can be used with stackers.

## Segmented Panels

### 42"H Base panels

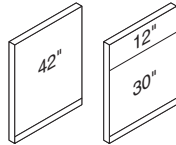

### 48"H Base panels

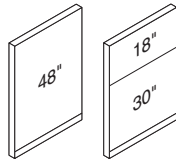

### 54"H Base panels

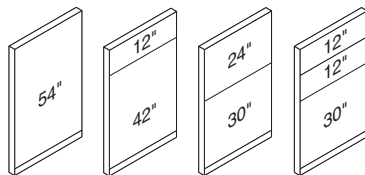

### 66"H Base panels

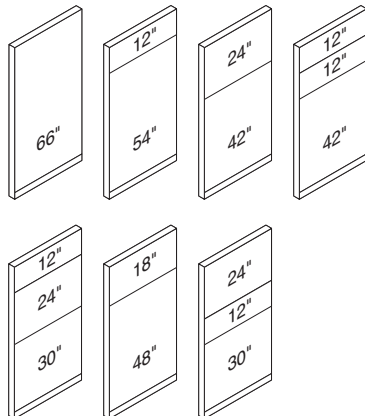

## Stacker Options

### 42"H Base panels with stacker

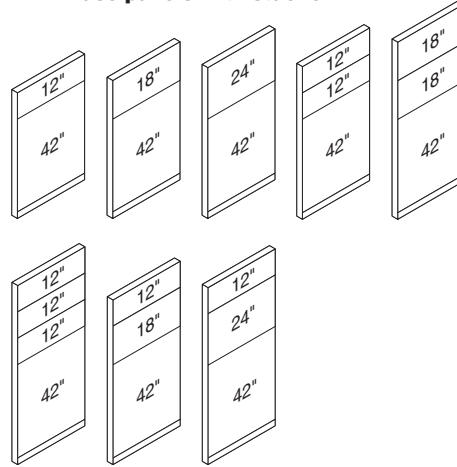

### 48"H Base panels with stacker

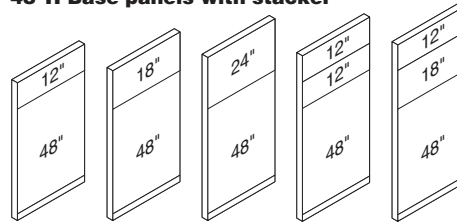

### 54"H Base panels with stacker

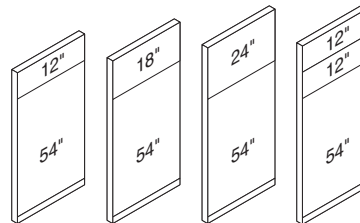

### 66"H Base panels with stacker





# Panel Stackers

**Stackers** are constructed with a rigid, tubular steel frame and are shipped fully assembled.

► Specifying, page 184.

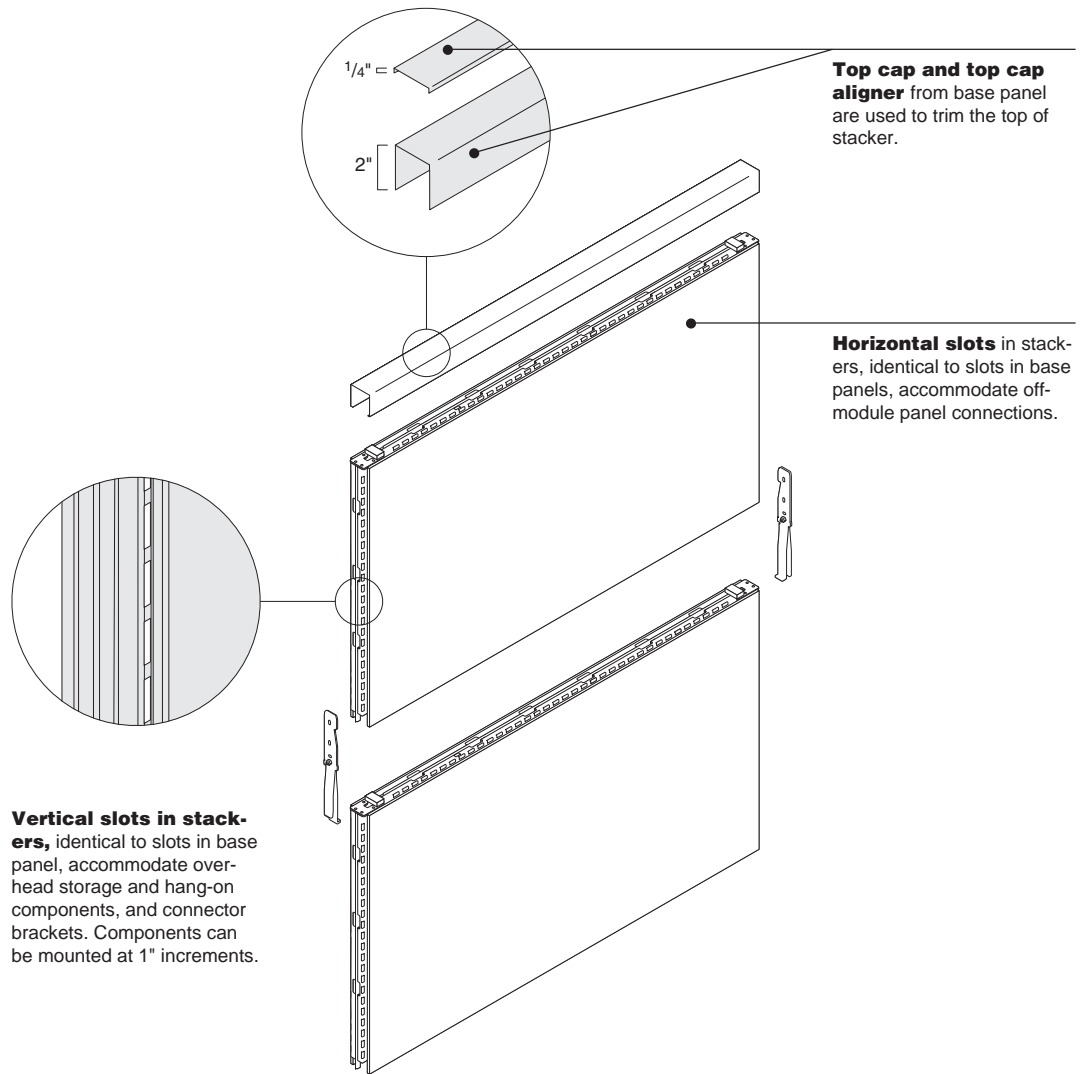

## Actual Dimensions

<b>Height</b>	12", 18", or 24"
<b>Width</b>	24", 30", 36", 42", 48", 60", or 72"
<b>Thickness</b>	2"

**Product Details**

**All existing base panels** accept stackers.

**Stackers** do not include vertical trim, must be specified separately.

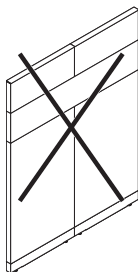
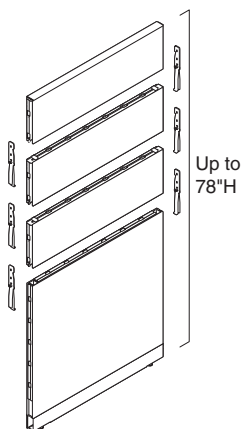

**Two smaller stackers** cannot be attached to the top of a larger stacker or panel.

**Kick stackers** are available in two surface options.



**Tackable acoustical**—skin on each side, covered with vertical surface fabric.



**Glass**—single pane of clear, tempered safety glass on panel centerline, surrounded by painted border.

**Base panels** can accept one, two, or three stackers, up to a total height of 78". Base panels can only accept one glass stacker. All stackers are load bearing, but load cannot be mounted above 66" height.

▶ See page 12.

**Two fork connectors** are included with every stacker.

**Attaching stackers to panels** will not cause disruption to existing panel connections.

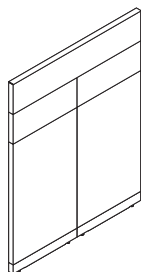

**Spanning stackers** are available in 48", 60", or 72".

**Stacker** can span over an in-line connection between two base panels or two stackers. Width of stacker must equal total width of two base panels.

**Application Topics**

**Maximum height with base panel and stackers** cannot exceed 78".

**Maximum number of stackers** is three.

**Any base panel** can accept stackers.

**Bins and shelves** can hang from first or second stacker, not above 66" in height.

**When** adding a stacker to existing panels with a power or cable pole connected at L-, T-, or X- corner, the universal panel connector can not be used. Order service part **TS100574SR** and use the special panel connector for poles to make the connection.

**Surface Materials**

**Border**

- Paint

**Panel surface**

- Fabric
- 6500 Clear Glass

# Panel Connectors

**Universal connector package** joins panels of the same height in a straight line or in L-, T-, or X-configurations. The package, included with panels, contains two universal connectors—one for the top and one for the bottom connection.

► Specifying, page 191.

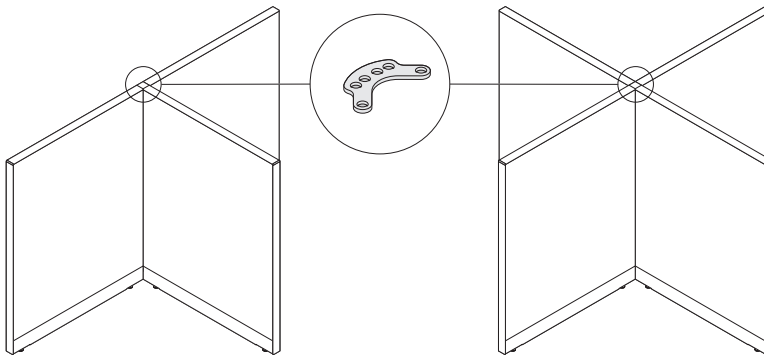
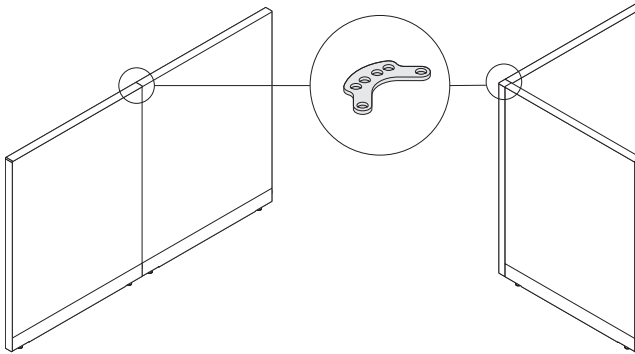

**Same connector** is used at both the top and bottom of panel.

**Different slots** are used to create in-line, L-, T-, or X-conditions.



Left Hand  
Right Hand  
Change-of-Height Connector



Universal Connector



120° Connector

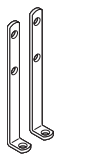

Wall Start

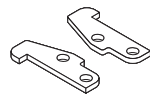

Top brackets

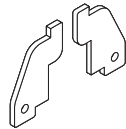

Bottom brackets

Off-Module Connector—Universal

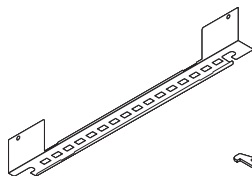

Bottom slotted rail



Top brackets



Bottom brackets

Off-Module Connector—Panel Width-Specific

## Product Details

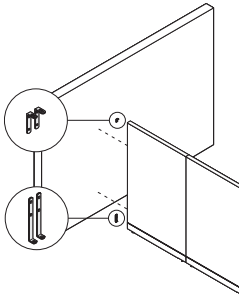

**Wall start connector package** is used to anchor a panel run to a perpendicular wall. Mounting screws that connect the brackets to the panel are included in each package.

*Tip: Vertical end-of-run trim is not required at the end of panel that is attached to the wall.*

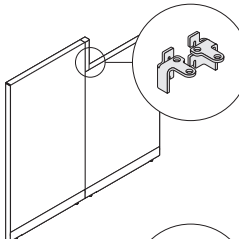

**Change-of-height in-line and corner panel connector package** is used to join panels at varying heights in a straight line or at 90° angles. Package contains left and right connectors for both in-line and corner configurations.

*Tip: Change-of-height in-line and corner panel connectors cannot be used in 120° configurations.*

**Left and right in-line connectors** are required to connect panels in a straight line.

**One-handed corner connector** is required for connecting panels at 90°.

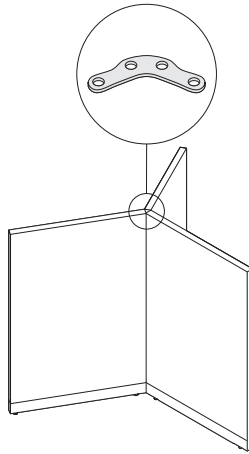

**To connect panels in a 120° application**, a 120° panel connector is required. A two-panel connection requires one 120° connector package. A three-panel connection requires three 120° connector packages.

*Tip: Change-of-height in-line and corner panel connectors cannot be used in 120° configurations.*

► Page 191

**120° connectors** are for the same height panels only.

**120° and 90° connections** can occur within the same workstation.

## Surface Materials

### Universal and 120° connector

- 0835 Black

# Off-Module Connections

**Kick** offers true off-module capability with the ability to mount a return panel anywhere along the spine in 1" increments.

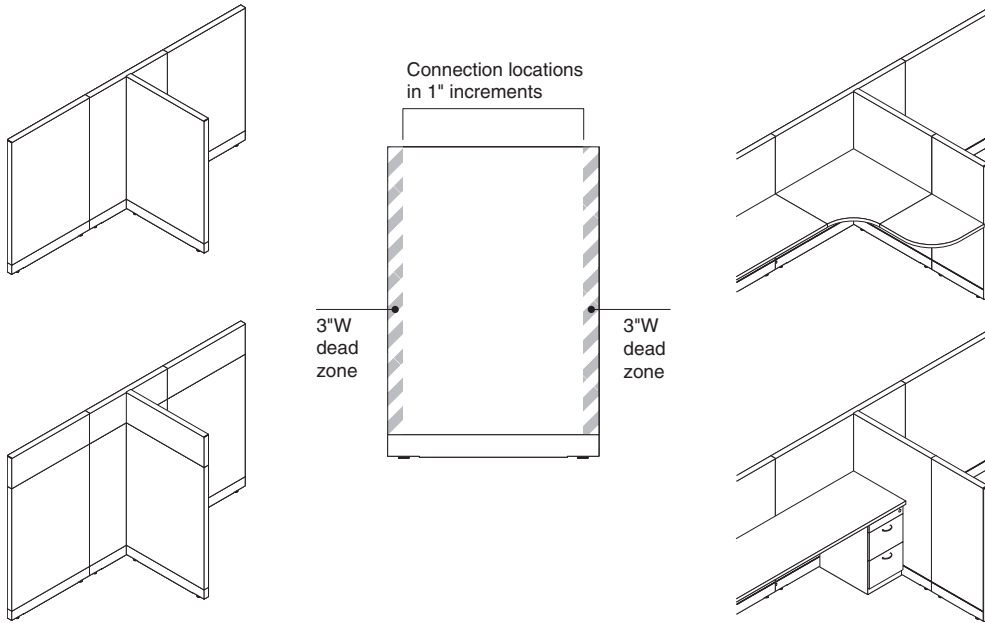

## Product Details

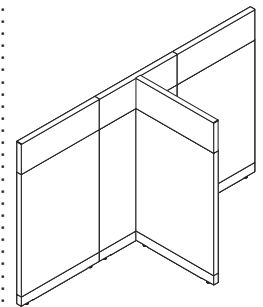
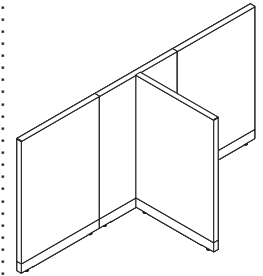

**Off-module connectors** connect all types of Kick panels of the same height. Connection locations are at 1" increments and allow the use of standard-size worksurfaces for workstation planning. Stackers can be mounted on either or both of the panels. There is a dead zone at the last 3" of each end of the panel where an off-module connection cannot be made due to lack of horizontal mounting slots.

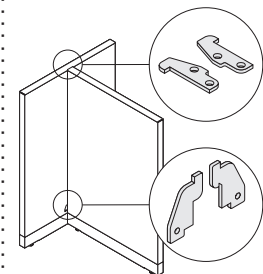

### Off-Module Connector—Universal

Bottom connection requires the use of two self-drilling screws (included) through the skin of the host panel approximately 1/2" above the base cover.

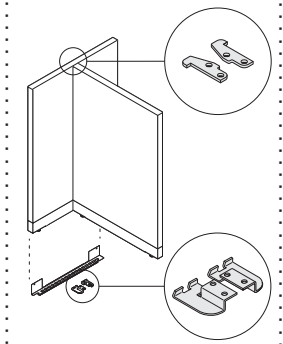

**Off-Module Connector—  
Panel-Width Specific**

The panel width-specific off-module connector incorporates a horizontal element that connects to the base feet of the host panel. There is no defacing of either panel.

# Panel Trim

**Steel top caps** are available in two heights—low is standard and high is available as an option. High top cap will accommodate cable routing at the top of the panel.

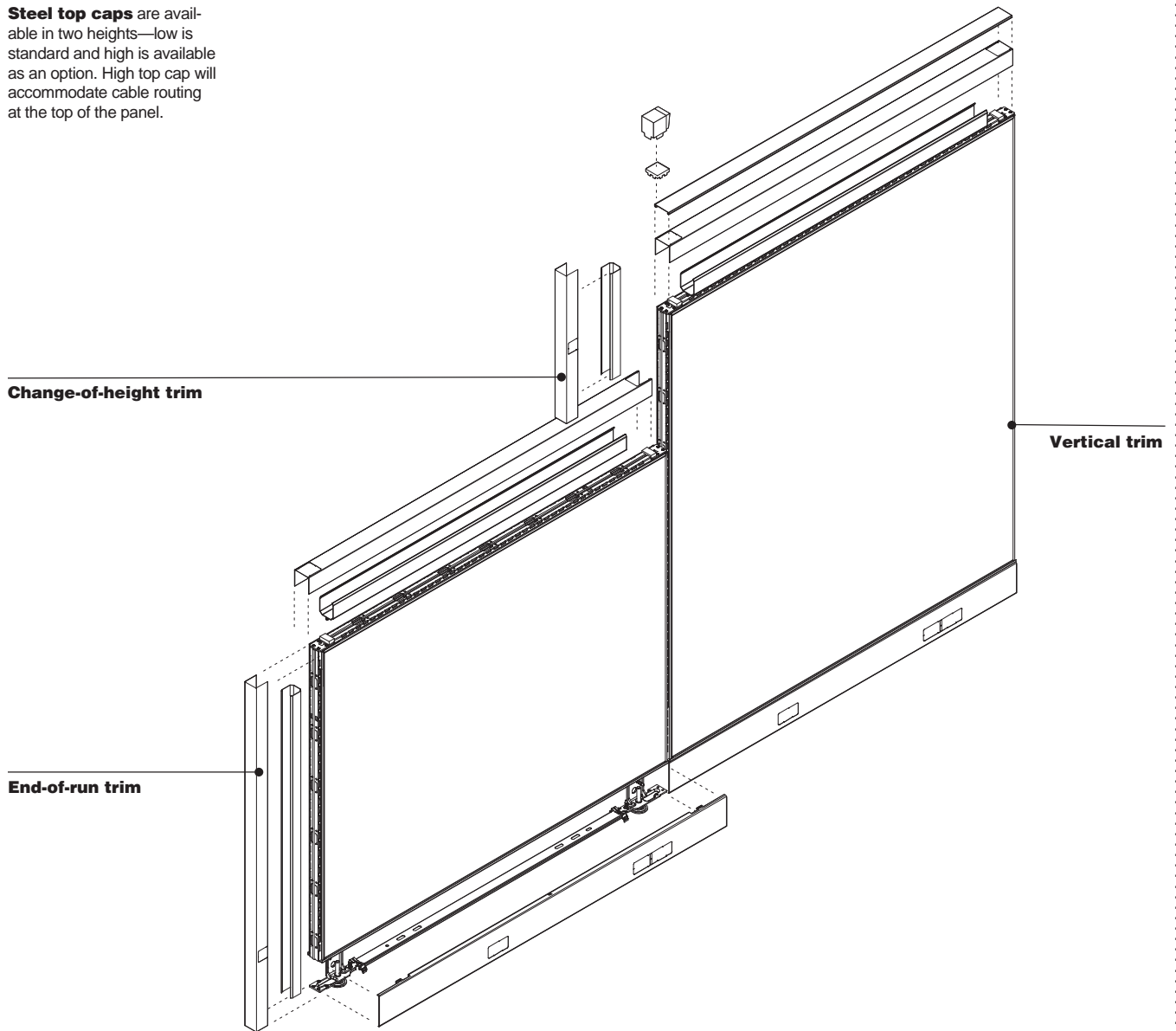

## Actual Dimensions

	Vertical Corner Trim	End-of-Run Trim	Change-of-Height Trim
Height	42", 48", 54", or 66"	42", 48", 54", 60", 66", 72", or 78"	6", 12", 18", 24", or 36"
Standard Thickness	1/4"	1/4"	1/4"
High Cable Capacity Thickness	2"	2"	2"

**Product Details**

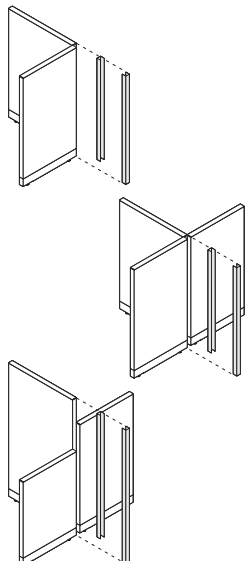

**Vertical corner trim** allows cables to be laid in before the cover is snapped into place and can be removed for cable access. Corner trim is required for L-, T-, and X-configurations and includes a low trim end cap. High trim end caps, available as an option, are application specific.

**Always specify vertical corner trim** the same height as the tallest panel.

**L-configurations:**

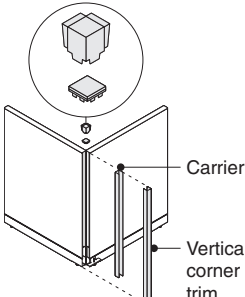

High L end cap or low universal end cap

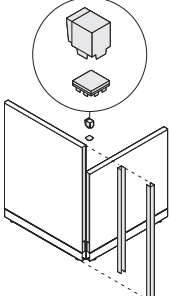

High end-of-run cap or low universal end cap

**T-configurations:**

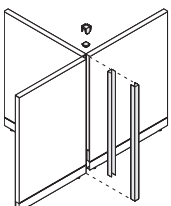

High T end cap or low universal end cap

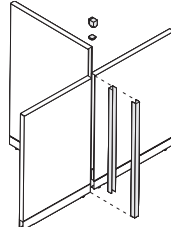

High end-of-run cap or low universal end cap

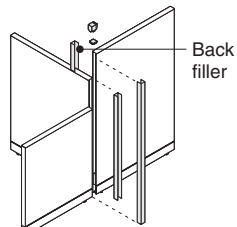

High end-of-run cap or low universal end cap

*Tip: Back filler required for cable routing capability and non-sequential assembly only.*

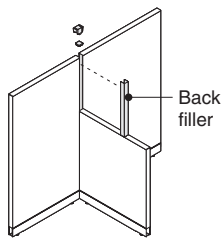

High in-line cap or low universal end cap

*Tip: Back filler required for cable routing capability and non-sequential assembly only.*

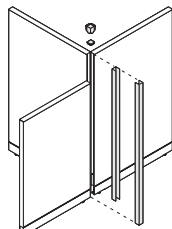

High L end cap or low universal end cap

**X-configurations:**

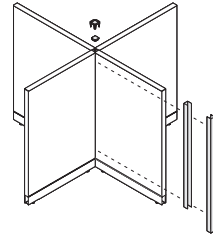

High X end cap or low universal end cap

*Tip: In an X-configuration, carrier and vertical corner trim must be attached to one panel prior to installation of last panel.*

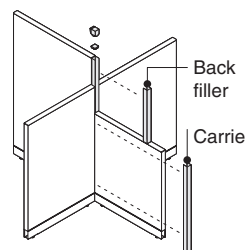

High end-of-run cap or low universal end cap

*Tip: Back filler required for cable routing capability only.*

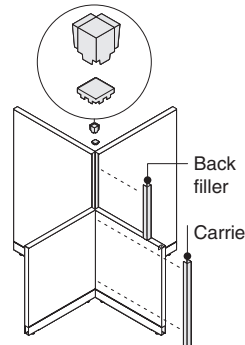

High L end cap or low universal end cap

*Tip: Back filler required for cable routing capability only.*

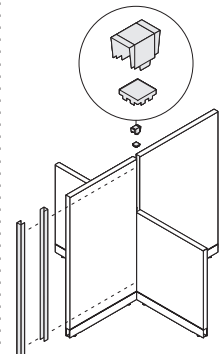

High in-line cap or low universal end cap

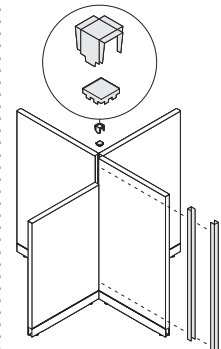

High T end cap or low universal end cap

**End caps:**



High T end cap



High end-of-run cap



High in-line cap



High L end cap



High X end cap



Low universal end cap

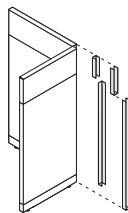
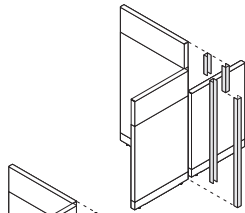
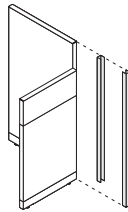

**Vertical corner trim and corner change-of-height trim** are required in combination for L-, T-, and X-configurations when stackers are used. All corner trims include a low trim end cap. High trim end caps, available as an option, are application specific.

**Always specify vertical corner trim** the same height as the tallest base panel. Specify vertical corner change-of-height trim to cover the ends of stackers.

**Vertical end-of-run trim** covers the exposed end of panels and includes a low trim end cap. High trim end caps, available as an option, are application specific.

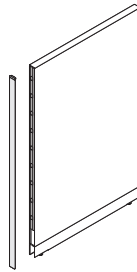

**Vertical end-of-run trim** must match height of base panel.

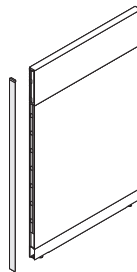

**Vertical end-of-run trim** must match combined height of base panel and stacker.

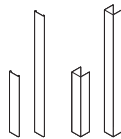

**Vertical in-line change-of-height trim** is available 6"H, 12"H, 18"H, 24"H, and 36"H in slim profile (standard with a low trim end cap) or with cable-routing capacity (standard with a high trim end cap). Trim covers the exposed section of the taller panel when panels of different heights are joined.

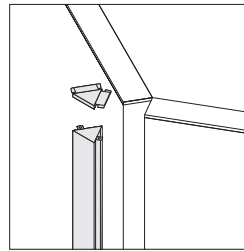

**120° vertical corner trim** is required for all 120° connections. The same 120° vertical corner trim is used for two- and three-way connections and is available with a low end cap only. Both two- and three-way end caps are included with each 120° vertical corner trim package.

▶ Page 189

**Application Topics**

**Always** specify vertical corner trim the same height as tallest panel.

**When specifying a base panel and a stacker**, specify corner trim to match base panel and change-of-height trim piece to cover the ends of stacker.

**When base panel and stacker** are specified in end-of-run trim must match total overall height.

**Surface Materials**

- Trim**
- Paint



# Sliding Panel Door

**Sliding door** is handed and can be added to workstations for additional privacy.

**Door** must be installed on the outside of the workstation.

**Receiving panel height** must match door height.

**Door** is attached to the host panel only; therefore, the stability of the door is closely related to the stability of the host panel.

**The sliding door infill** is standard in ribbed, translucent plastic. Clear tempered glass and white laminated glass are available as options.

**Sliding door** can be specified with lock option. Specify lock cylinder and key separately.

**Sliding door** is not freestanding; it must mount to panels.

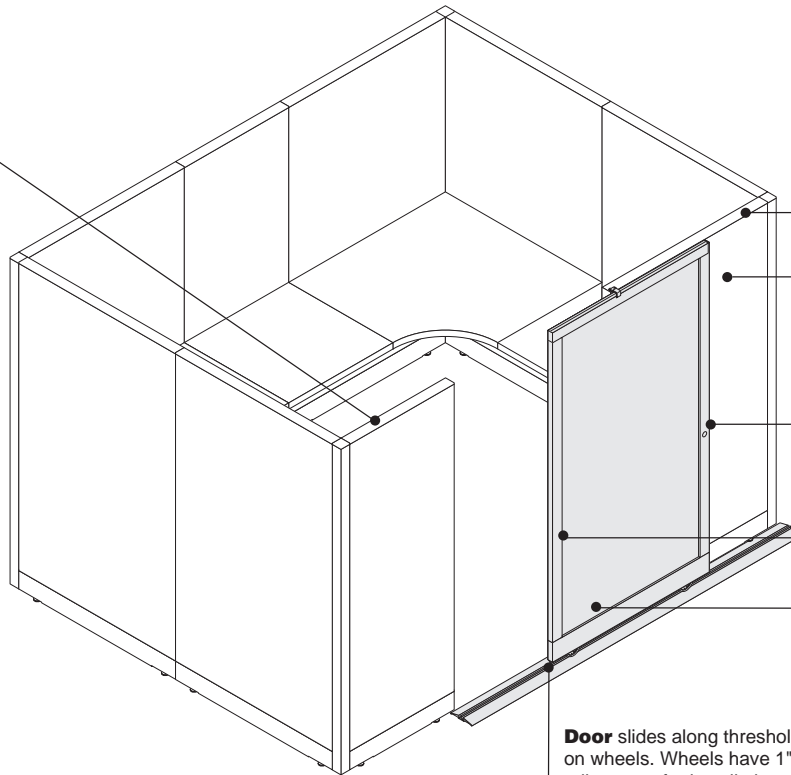

**Height of host panel** must match height of door.

**Sliding door frame and threshold** are constructed from extruded aluminum and painted.

**Lock mechanism** is on the right-hand side of a left-hand sliding door.

**Door handle** is integral and is ADA compliant.

**Left-hand sliding door** closes from right to left.

**Door** slides along threshold on wheels. Wheels have 1" adjustment for installation on uneven floors. Threshold is ADA compliant.

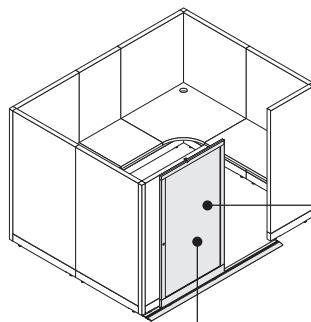

**Right-hand sliding door** closes from left to right.

**Lock mechanism** is on left-hand side of a right-hand sliding door to lock into the host panel.

## Actual Dimensions

<b>Height</b>	66" or 78"
<b>Width</b>	36" or 42"
<b>Thickness</b>	1¼"

### Product Details

**Sliding door** is handed. Right-handed sliding door or left-handed sliding door must be specified.

**Sliding door** can be specified with lock option. Specify lock cylinder and key separately.

**Door insert** is standard in ribbed, translucent plastic. Clear tempered glass and white laminated glass are available as options.

### Application Topics

**Sliding door** is not free-standing. It must mount to panels.

**Door** is attached to the host panel only. Therefore, the stability of the door is closely related to the stability of the host panel.

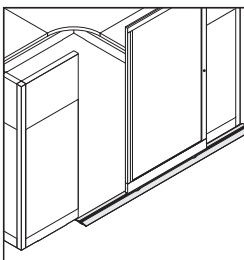

**Door track** is attached to both host panel and opposite panel.

**Height of door** must match height of host panel - 66"H or 78"H.

**Match** the width of the host panel to the width of the door.

**Sliding panel door** cannot attach to a host panel with a double-pane window.

### Surface Materials

#### Panel door frame

- Paint

#### Door insert

- 6500 Clear Glass
- 6541 White Laminated Glass
- 6625 Translucent Plastic

# Stability Guidelines

**Counterweight packages for storage products** are required to ensure product stability.  
▶ See page 111 for *Counterweight Requirements for Storage Products*.

## Tackable Acoustical Panels without Components

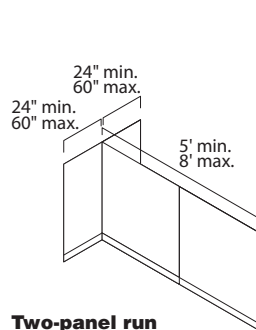

**Two-panel run**

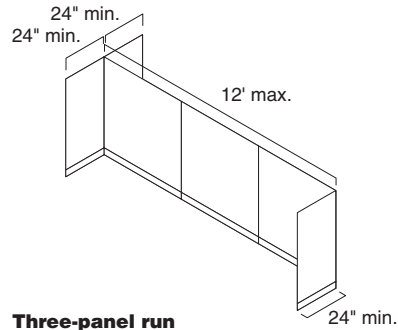

**Three-panel run**

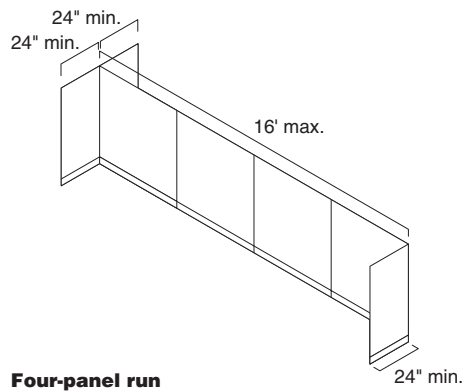

**Four-panel run**

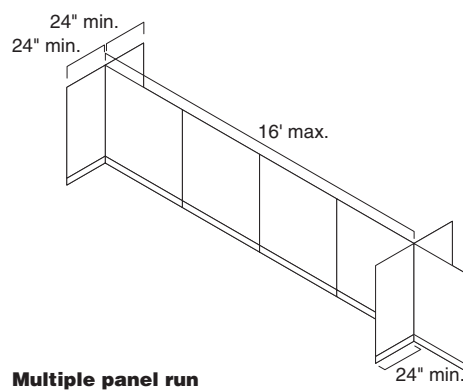

**Multiple panel run**

## Tackable Acoustical Panels

### Two-Panel Run with Supported Components

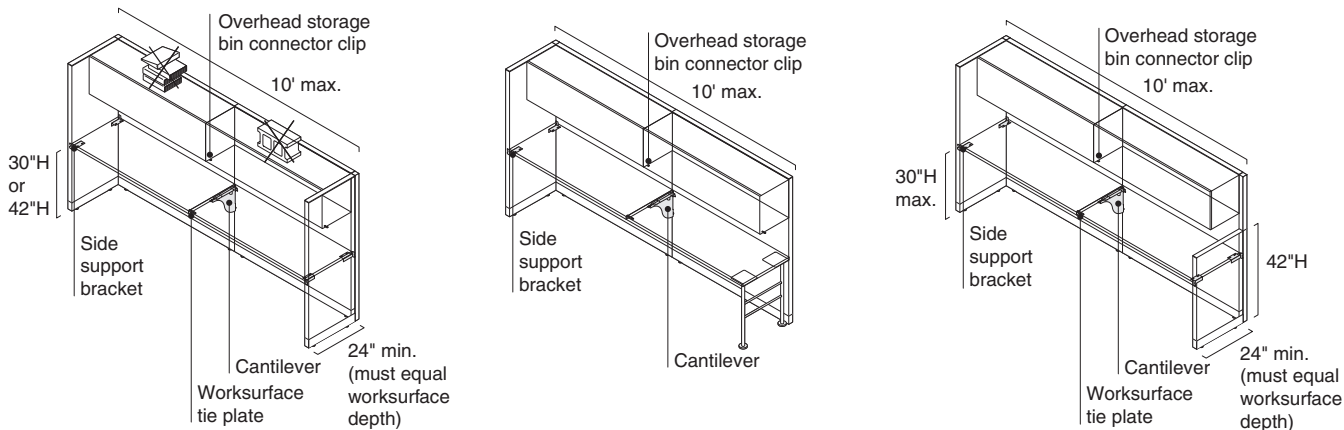

**Optional worksurface supports:**

- 20\"W H-leg
- Pedestal with filler
- Lateral file
- End panel

*Tip: Kick overhead storage bins cannot support any load on top.*

### Two-Panel Run with Upmount Bin Bracket

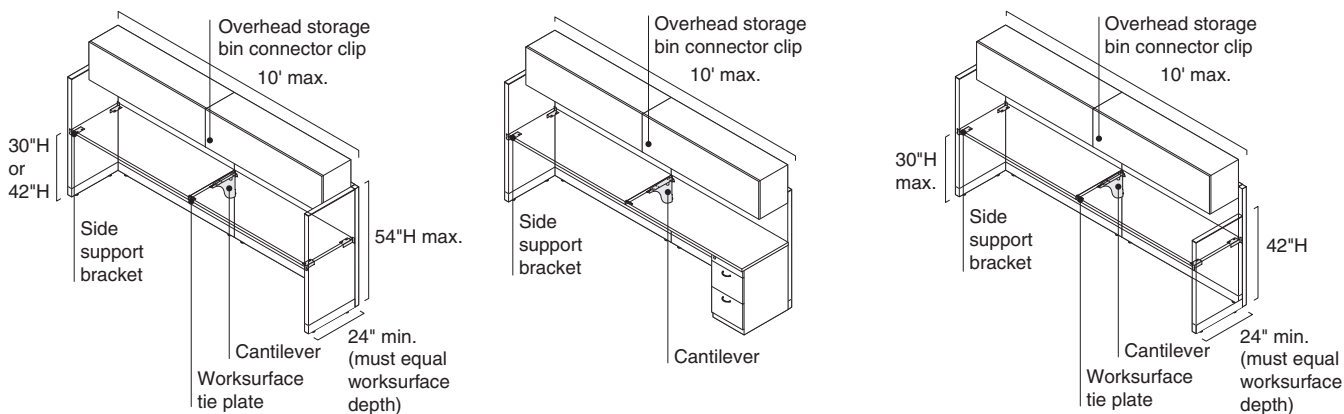

**Optional worksurface supports:**

- Pedestal with filler
- End panel

*Tip: Kick overhead storage bins cannot support any load on top.*

*Tip: Upmount bin brackets cannot be used in three-panel runs or 120° panel configurations.*

**Tackable Acoustical Panels, continued**

**Three-Panel Run with Supported Components**

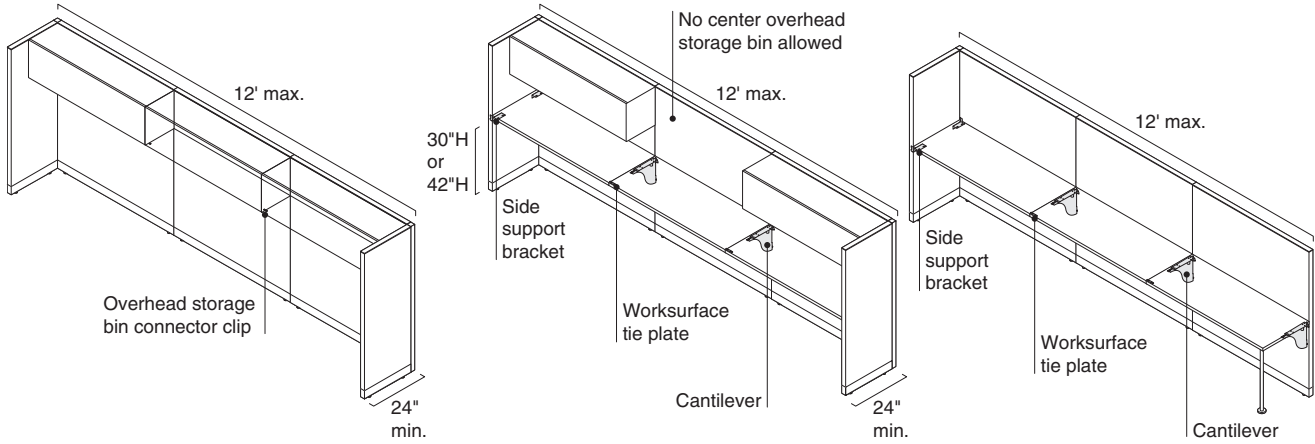

**Optional worksurface supports at 30\"/>**

- 20\"/>

*Tip: Kick overhead storage bins cannot support any load on top.*

**Tackable Acoustical Panels without Components**

**120° Connection**

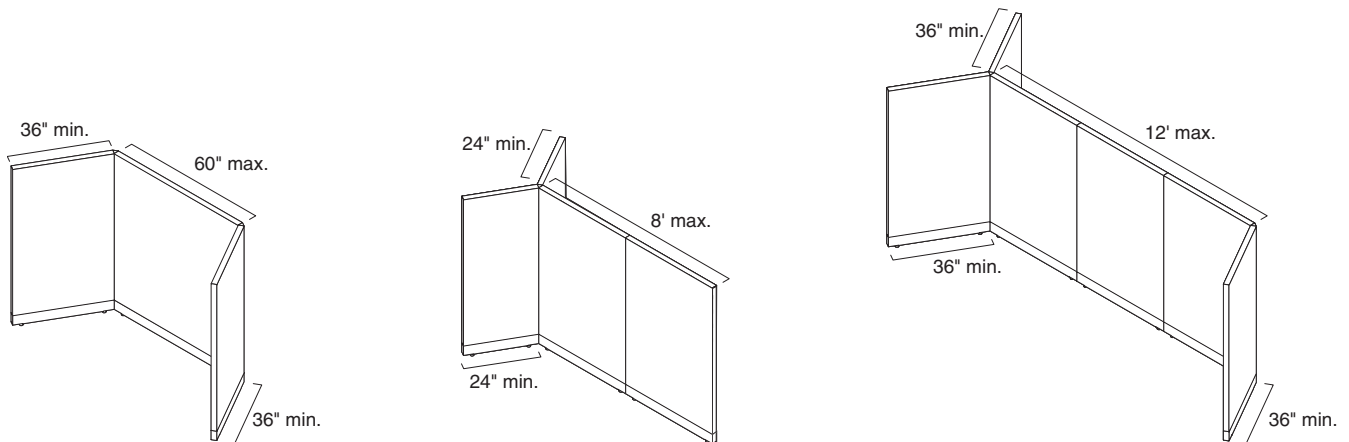

**Tackable Acoustical Panels with Supported Components**

**One Panel—120° Connection**

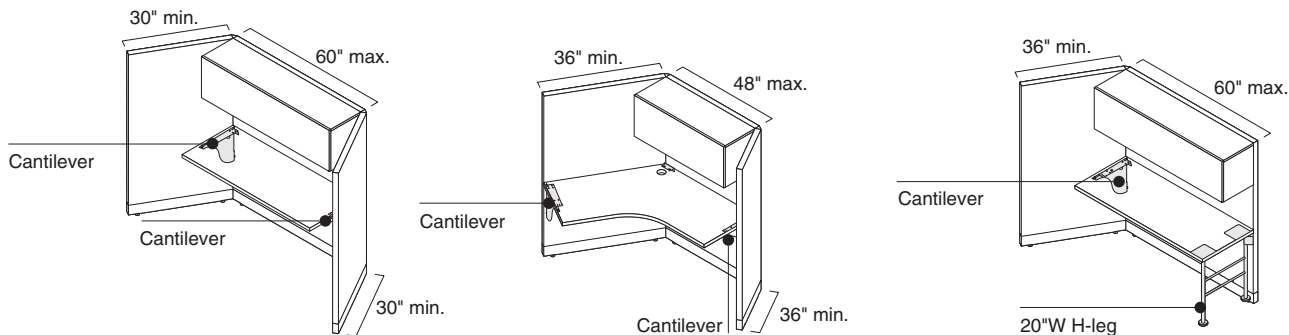

**Optional worksurface supports:**

- Pedestal with filler
- 90° panel connection—panel width must match worksurface depth
- End panel

**Optional worksurface supports:**

- Pedestal with filler
- 90° panel connection—panel width must match worksurface depth
- 20"W H-leg

*Tip: Upmount bin brackets cannot be used with 120° panel configurations.*

**Two-Panel Run—120° Connection**

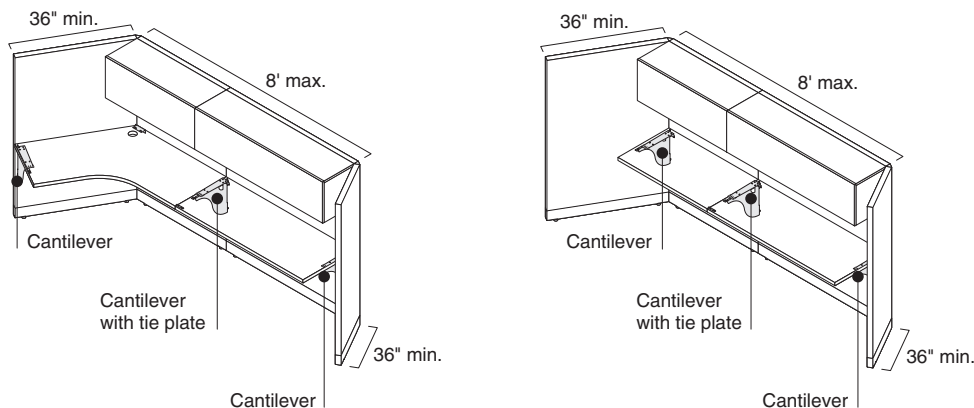

**Optional worksurface supports:**

- 20"W H-leg
- Pedestal with filler
- 90° panel connection—panel width must match worksurface depth

*Tip: Upmount bin brackets cannot be used with 120° panel configurations.*

**Tackable Acoustical Panels with Supported Components, continued**

**Three-Panel Run—120° Connection**

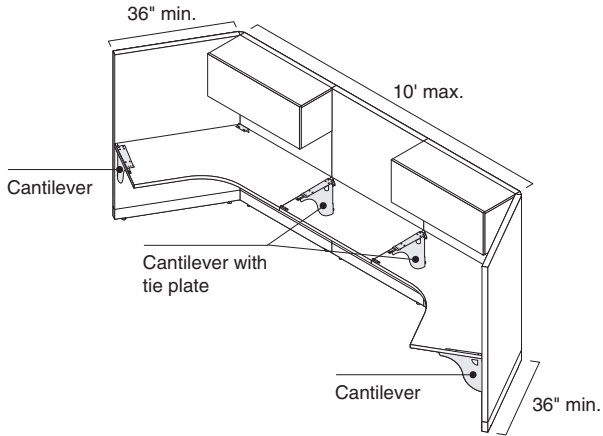
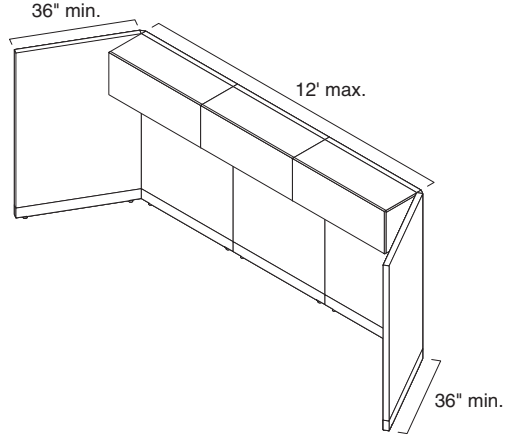
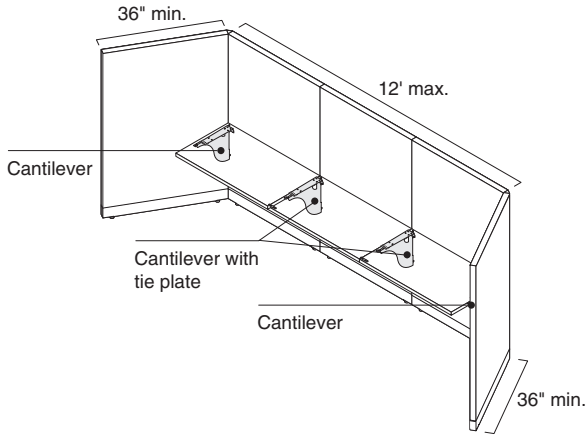

*Tip: Same rule applies if using 120° worksurfaces in place of straight worksurfaces.*

*Tip: Upmount bin brackets cannot be used with 120° panel configurations.*

**Tackable Acoustical Panels—Three-Way 120° Connection**

**Three Panel 120° Connection with One Supported Component**

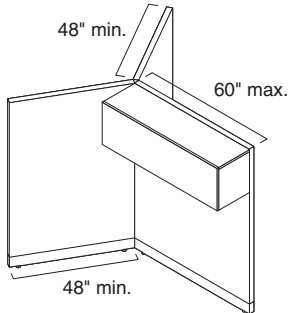

*Tip: Upmount bin brackets cannot be used with 120° panel configurations.*

**Three Panel 120° Connection with 120° Worksurface and up to One Additional Component**

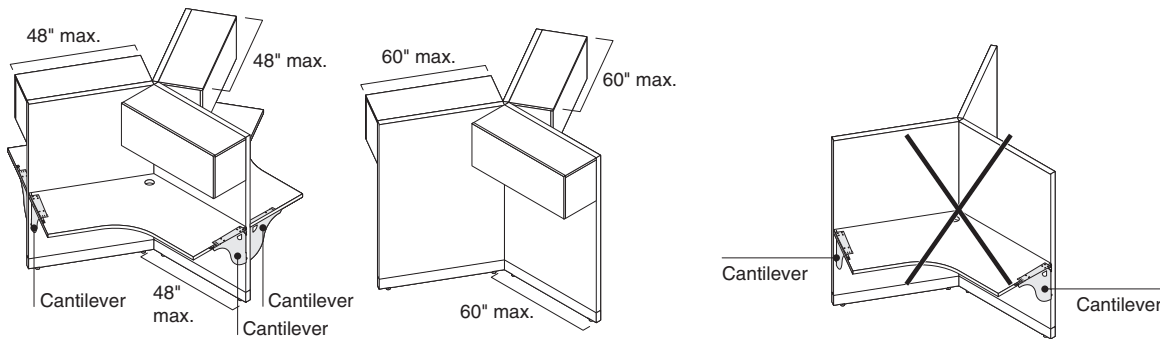

*Tip: Loads must be counterbalanced in this application.*

*Tip: Worksurface needs to be supported to floor or application needs to be counterbalanced.*

**Panels and Panel Stackers**

**Base panels** can accept one, two, or three stackers, up to a total height of 78". Base panels can accept only one glass stacker. Glass stacker cannot be used on glass panel. See below for additional rules and exceptions.

**Universal or change-of-height connectors** must be used at top of base panel and each stacker wherever possible to increase stability.

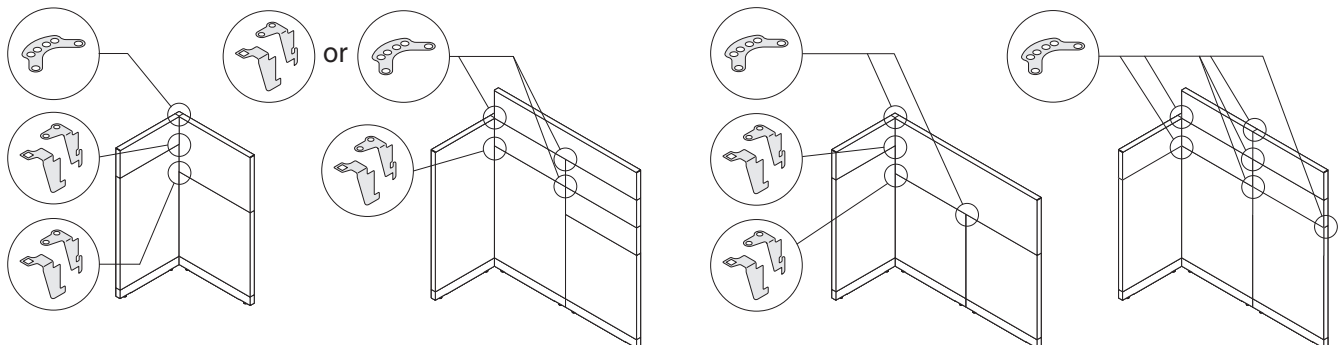

**Panels and Panel Stackers, continued**

**All stackers** are load bearing, but load cannot be mounted above 66" height.

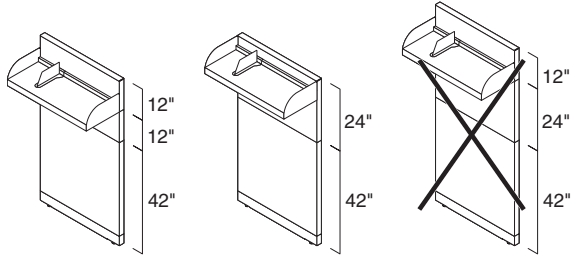

**Glass stackers on acoustical panels without components** follow the same rules as tackable panels, with the exception of the T-configuration below.

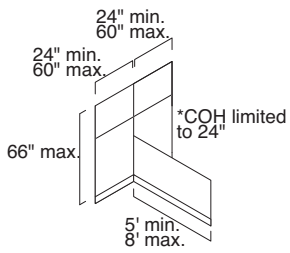

**12" or 24" Glass stacker**

**Glass Panels**

**Glass panels** do not allow stackers. The return on the glass panel can be any type of material.

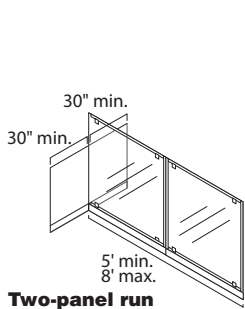

**Two-panel run**

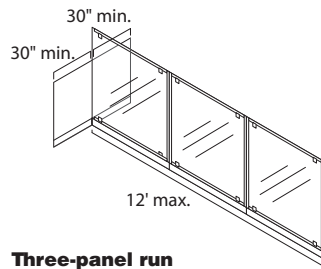

**Three-panel run**

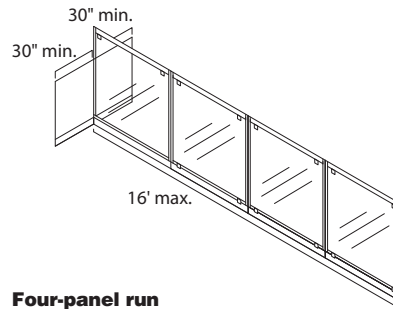

**Four-panel run**

---

# Understanding Wiring and Cabling

---

	
<b>Statement of Line</b>	<b>34</b>

	
<b>Circuit Specifications</b>	<b>35</b>
<b>How to Calculate Power Needs</b>	<b>36</b>
<b>Special Requirements for Chicago</b>	<b>37</b>
<b>Cable Capacities</b>	<b>38</b>
<b>Powerway</b>	<b>40</b>
<b>Receptacle</b>	<b>42</b>
<b>Power and Cable Pole</b>	<b>44</b>
<b>Base Power-in</b>	<b>46</b>
<b>Worksurface-Height Power and Communication</b>	<b>52</b>

# Statement of Line



**Receptacles**  
▶ Page 42

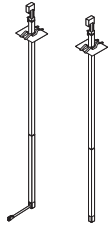

**2" x 2" Power and Cable Poles**  
▶ Page 44



**Base Power-Ins**  
▶ Page 46

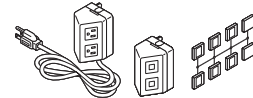

**Panel-Mounted Receptacle Package and Communication Module Package**  
▶ Page 52

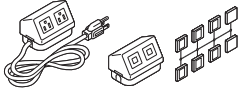

**Worksurface-Mounted Receptacle Package and Communication Module Package**  
▶ Page 52

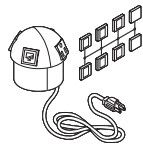

**Worksurface-Mounted Power and Communication Sphere**  
▶ Page 52

**Five wiring schematics** are available for Kick—two 3-circuit systems and three 4-circuit systems.

**All the components in an electrical distribution network** must use the same wiring schematic. The components (power poles, base power-ins, powerways, and receptacles) snap together and are keyed to make it impossible to connect mismatched parts. Color-coded and labeled components make it easy for installers to identify which wiring schematic each component is dedicated to.

**Color coding:**

- For power components manufactured before June 19, 2023:
  - 3 circuits shared = Black
  - 3 circuits separate = White
  - 4 circuits 3+D = Black
  - 4 circuit 3I+1 = Tan
  - 4 circuit 2+2 = Grey

- For power components manufactured on or after June 19, 2023:
  - 3 circuits shared = Blue
  - 3 circuits separate = Rust
  - 4 circuits 3+D = Black
  - 4 circuit 3I+1 = Black
  - 4 circuit 2+2 = Brown

## Overview

**Three-circuit electrical components with shared neutrals** are standard with 5 wires to provide three circuits that share one oversized neutral and one ground.

**Three-circuit with separate neutrals** have 8 wires providing three circuits, each with its own separate neutral. The first two circuits share an isolated ground; the third uses the system ground.

**Four-circuit 3+D** are standard with 8 wires to provide four circuits. Three of these circuits share an oversized neutral and a system ground while the remaining circuit has its own neutral and isolated ground.

**Four-circuit, 3I+1** again have 8 wires but with three circuits that share an oversized neutral and isolated ground. The fourth circuit has its own neutral and is attached to the system ground. This electrical system is like the standard 3+D, but the grounds are switched, providing three isolated circuits and one general purpose circuit as compared to one isolated circuit and three general purpose circuits.

**Four-circuit 2+2** also have 8 wires but provide two circuits that share an oversized neutral and a system ground and an additional two circuits with a second oversized neutral and an isolated ground.

### 3 Circuit Shared Neutral, 5 Wires

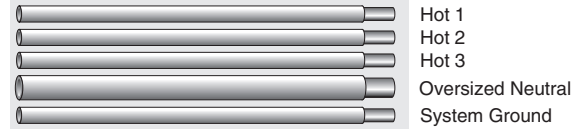

### 3 Circuit Separate Neutral, 8 Wires

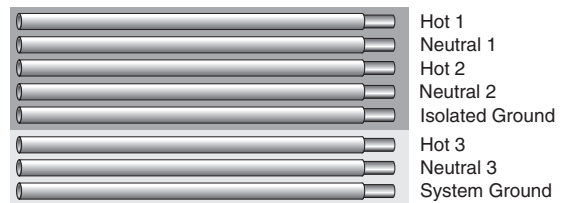

### 4 Circuit 3+D, 8 Wires

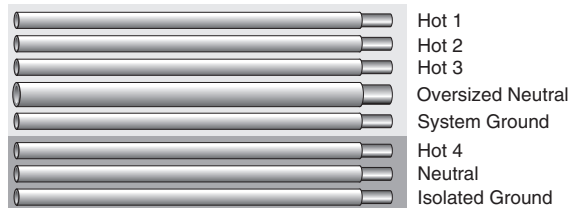

### 4 Circuit 3I+1, 8 Wires

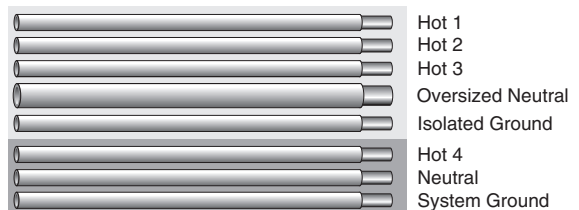

### 4 Circuit 2+2, 8 Wires

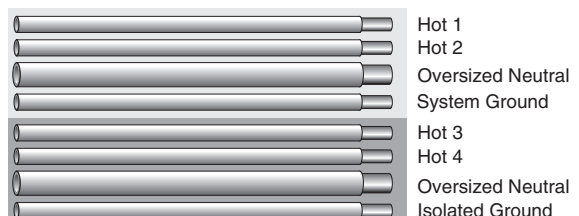

# How to Calculate Power Needs

Use This to Determine How Many Power-Ins You'll Need

**When planning a power network,** you must calculate the amperage requirements of all your electrical components so you can provide sufficient electricity to power them.

**If your usage is not known in advance:**

The National Electrical Code (NEC) allows a maximum of 13 receptacles on each 20-amp circuit. This provides up to 30 receptacles for each 3-circuit power-in.

**If your usage is known in advance:**

Add up the amperage used by each piece of equipment in the workstation. Whenever you reach 60 amps (20 amps times 3 circuits) from items that are likely to be used at the same time, you have reached the limit for a single power-in. Specify another power-in and continue until all equipment is powered.

If the circuits will normally be subject to a continuous load (three or more hours of continuous use, such as lights or computers), the NEC requires that circuit capacity be "de-rated" by 20 percent. Therefore, treat circuits used for continuous loads as if they were rated at 16 amps instead of the regular 20 amps.

Try to anticipate future increases in power requirements and build some excess capacity into your plan.

▶ See table at right for typical and actual amperage usages for components.

To calculate amperage when the wattage of a device is known, divide watts by 120.

Some appliances, such as large copiers, coffee makers, or space heaters require most of the current available on a 20-amp circuit. It is recommended that such devices be supplied with their own receptacle/circuit, directly from the building. This leaves the capacity of the furniture circuits available for the more dynamic requirements of the office equipment.

Local electrical codes vary. Consult a qualified electrical contractor or engineer for the proper planning of electrical circuits in your locale.

**Approximate power consumption for common devices**

• Device	• Wattage	• Amperage	• Voltage	• Number of Devices Supported on Single 20 Amp Circuit*
Laptop	90	0.8	110	20
CPU/Desktop Computer	120	1.1	110	15
Monitor	60	0.5	110	29
Phone	5	0.0	110	352
High Power Tablet (e.g. Surface Pro)	40	0.4	110	44
Low Power Tablet (e.g. iPad Air)	15	0.1	110	117
Desktop Printer	40	0.4	110	44
42" LCD Screen	210	1.9	110	8
DVD Player	25	0.2	110	70
Projector	175	1.6	110	10
Desktop Lamp	19	0.2	110	93
Large Printer/Copier (high)	1900	17.3	110	1
Large Printer/Copier (low)	850	7.7	110	2
Paper Shredder	360	3.3	110	5
Desktop Fan	20	0.2	110	88
Standing Fan	180	1.6	110	10
Coffee Maker (high)	1200	10.9	110	1
Coffee Maker (low)	600	5.5	110	3
Microwave (high)	400	13.6	110	1
Microwave (low)	150	5.5	110	3
Refrigerator (high)	1500	3.6	110	4
Refrigerator (low)	200	1.4	110	12
Vacuum (high)	1500	13.6	110	1
Vacuum (low)	200	1.8	110	9
Space Heater (high)	1500	13.6	110	1
Space Heater (low)	750	6.8	110	2

*Tip: These calculations are estimations and are meant solely for informational purposes. It is important to conduct proper power planning for each installation to prevent overloading a circuit.*

# Special Requirements for Chicago

	Chicago Code	Specification:	Electrician will supply:
<p><b>Panel Requirements</b></p> <p><b>Chicago code</b> requires hardwiring of all electrical components.</p>	<p><b>Panel</b> must be hardwired in the field.</p> <p><b>Electrician hardwires</b> all receptacle boxes and conduits into panel bases in the field. <i>Tip: Panel depth prohibits use of standard device boxes for back-to-back receptacles in Chicago.</i></p>	<ul style="list-style-type: none"> <li>• <b>Order panels</b> with factory-installed power base covers with receptacle knockouts where you intend to install receptacles. <i>Tip: Chicago code doesn't require a special base cover with different receptacle locations.</i></li> <li>• <b>Receptacles</b> in Chicago are supplied by electrician. Because these receptacles will be duplex size, you must order a filler plate to occupy the remaining space in larger-size openings. Reusable filler plates are available from Service Parts. <i>Tip: Because receptacles in Chicago cannot be installed back-to-back, you may want to avoid powered panels that are 30"W or less. These panels only have one receptacle location on each side, so these panels can only accommodate one duplex-size receptacle.</i></li> <li>• <b>Order corner fillers</b> for L-, T-, and X-configurations separately to conceal electrical conduits.</li> </ul>	<ul style="list-style-type: none"> <li>• Connection to building power supply</li> <li>• Wires</li> <li>• Fittings</li> <li>• Duplex receptacle (Leviton 5325-Decora style)</li> <li>• Electrical components</li> </ul>
<p><b>Lighting Requirements</b></p>	<p><b>Cords</b> must include integral overload protection.</p>	<ul style="list-style-type: none"> <li>• <b>Order Chicago version of shelf lights.</b></li> </ul>	

# Cable Capacities

## Test and verify capacities for your individual situation.

We recommend that testing be conducted using your specific cable, as well as the furniture configuration you are considering. Cable capacities in this table are based on actual cable studies performed by an independent contractor following EIA/TIA codes and practices and can be taken as an accurate assessment of maximum practical capacity. Actual cable capacities may vary slightly depending on which manufacturer produced the cable and the specific field conditions.

**Cable capacities** are based on Category 6 and Category 6a cables at 55% fill capacity.

*Tip: Low top cap does not accept any cables.*

### Cables Tested

**A CommScope  
Systimax Gigaspeed  
1071E Series  
Category 6 Cable  
OD=0.23"**



**B CommScope  
Systimax X10D  
1091B Series  
Category 6A Cable  
OD=0.285"**

**Powerways reduce cable capacity.** An average of 10-15 cables will be reduced per powerway used. However, this number varies according to installation practices and the type of cables used.

**If glass stacker is used at the top of a panel,** top cap lay-in cable capacity is 20 for category 6 cables.

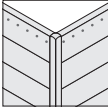
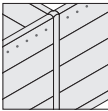
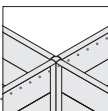
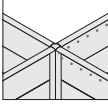
**When laying cables vertically behind skins,** capacity is dependent on skin width.

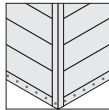
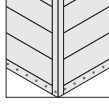
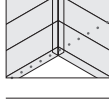
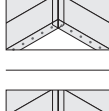
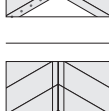
		A	B
<b>L, T, X, V, and Y Horizontal Routing</b>			
	Lay-in cable routing at top of panels in L or V configuration	25 Hi	20 Hi
	Lay-in cable routing at top of panels in T configuration	30 Hi	25 Hi
	Lay-in cable routing in top of panels in X or Y configuration	30 Hi	25 Hi
	Lay-in cable routing (around the corner) at the top of a panel in T or X configuration	25 Hi	20 Hi

		A	B
<b>L, T, X, V, and Y Horizontal Routing</b>			
	Lay-in cable routing (corner) at base of panel <b>with</b> power in L, T, or V configuration	9	5
	Lay-in cable routing (corner) at base of panel <b>without</b> power in L, T, or V configuration	32	21
	Lay-in cable routing (straight) at base of panel <b>with</b> power in X or Y configuration	9	5
	Lay-in cable routing (corner) at base of panel <b>with</b> power in X or Y configuration	9	5
	Lay-in cable routing (straight) at base of panel <b>without</b> power, or with powerway routed above in X or Y configuration	32	21
	Lay-in cable routing (corner) at base of panel <b>without</b> power, or with powerway routed above in X or Y configuration	32	21

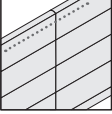
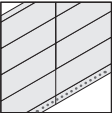
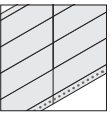
		A	B
<b>Straight Horizontal Routing</b>			
	Lay-in cable routing at top of panel	30 Hi	25 Hi
	Lay-in cable routing at base of panel <b>with</b> power	8	5
	Lay-in cable routing at base of panel <b>without</b> power or with powerway routed above	32	21

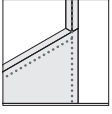
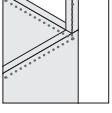
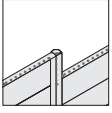
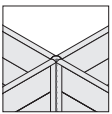
		A	B
<b>Straight Vertical Routing</b>			
	Vertical cable routing inside power pole (used on an end, L or T configuration an end)	28 Hi	18 Hi
	Vertical cable routing inside power pole	28 Hi	18 Hi
	Change in height (top)	13 Hi	9 Hi
	Through center of X	24	16

*Tip: Low top cap does not accept any cables.*

# Powerway

**Powerways** that are installed in the panel base cavity allow power to be distributed wherever panels go. They are concealed when properly installed. All five wiring schematics are available.

**On June 19, 2023, Kick power components**

changed design. Power components manufactured before June 19, 2023 are not compatible with power components manufactured after June 19, 2023.

▶ See *Power Components Transition Details* on page 48.

**All the components in an electrical distribution network** must use the same wiring schematic. Components are color coded and keyed to make it impossible to connect mismatched parts.

**All Steelcase electrical systems** are designed in compliance with the National Electrical Code (NEC) and Canadian Electrical Code (CEC) to function as a multi-wire branch circuit. Installations should be made in accordance with the NEC or CEC provisions for multi-wire branch circuits.

**Local electrical codes** vary. Consult a qualified electrical contractor or engineer for the proper installation of electrical equipment. Chicago, New York City, and Los Angeles have special requirements.

**Wire separator tray** supports the powerway and provides some space for cable routing.

**Power blocks of the powerway** are attached to the wire separator tray.

**Harness connectors** come attached to the powerway and connect the powerway to the powerway in an adjacent panel.

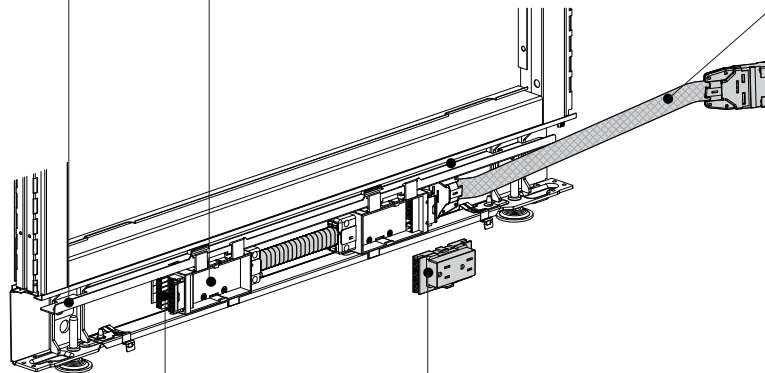

**Receptacles** snap into power block of the powerway.

**Two modular connections on end of powerkit** accept modular connectors of adjacent powerkit or power infeeds.

**Product Details**

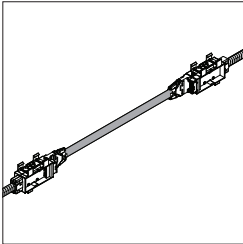

**Straight connection** is formed when a harness connector from one powerway attaches to the powerblock of the adjacent powerway.

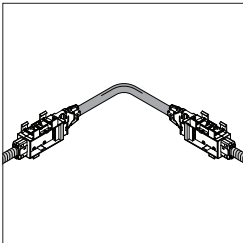

**L-connection** is formed when a powerway connector harness turns to the left or right and connects to the power block of the adjacent panel.

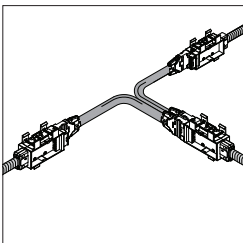

**T-connection** is formed by two powerway connector harnesses each turning in the same direction.

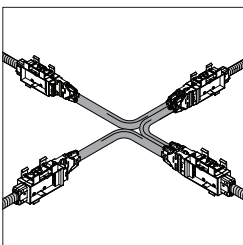

**X-connection** is formed by three powerway connector harnesses each turning in the same direction.

The **powerway connector harness** comes attached to each powerway and can be removed in field.

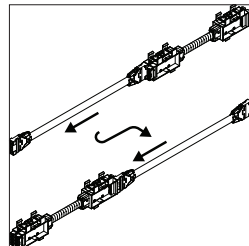

**Removing the powerway connector harness and adding it to the opposite end of the powerway powerblock** can be used to correct planning and installation oversights.

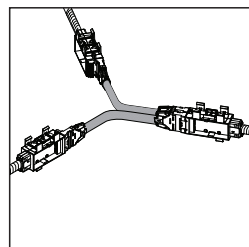

**Power** can be routed through the base of panels in a two- and three-panel, 120° connection.

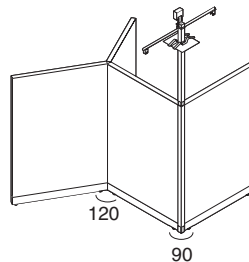

(inside measurement)  
**2" x 2" power and cable poles** can bring building power and data from the ceiling to a 120° panel application at the end of a run or 90° connection only.

**Application Topics**

**Factory included powerway for field installation** replaces need to order separate powerways.

**Field-installed powerways** can be ordered through Kick service parts.

**Wiring and Cabling**

**Chicago, San Francisco, and Los Angeles** have special requirements.

**Chicago electrical code** requires that all electrical connections be hardwired in the field. Order a non-powered panel and have the electrician obtain conduit and receptacles (Leviton 5325) to make the connections in the field.

**Underwriters Laboratory (UL)** listed. These products have been designed to meet U.S. and Canadian national electrical and energy codes and most local building codes. Local electrical codes vary, so consult with your local authority having jurisdiction as they have final say if the products as installed are compliant with local code. Consult with a qualified electrician or electrical engineer for proper installation of all electrical equipment.

# Receptacle

**Receptacles** are ordered separately and installed in the field in the base cover knockout opening. Receptacles snap into the power block in the field. Receptacles are designed to link to a specific circuit.

- ▶ Specifying, page 196

**On June 19, 2023, Kick power components** changed design. Power components manufactured before June 19, 2023 are not compatible with power components manufactured after June 19, 2023.

- ▶ See *Power Components Transition Details* on page 48.

**All receptacles** are duplex (two outlets) and are available in two versions - 15-amp and 20-amp.

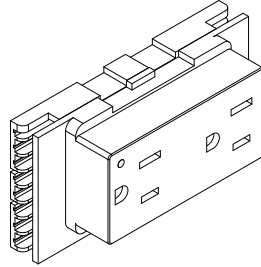

## Product Details

**Numbers** printed on the receptacles indicate the line number. Label on receptacle indicates which circuit the receptacle connects to, so the user can control which devices are on specific circuits.

**With the 3-circuit separate neutral system**, these designations are with letters A, B, or C as compared to 1, 2, 3, or 4 in the other systems.

**Specific circuits** are accessed through the powerway by installing the appropriate receptacle in the receptacle location. All five wiring schematics are available.

**All the components in an electrical distribution network** must use the same wiring schematic. Components are color coded and keyed to make it impossible to connect mismatched parts.

**Available** in 6000 Black plastic only.

**Receptacles** come in packages of six receptacles.

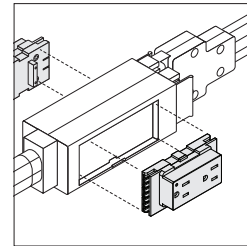

**Receptacles** snap into both faces of the power block in the field.

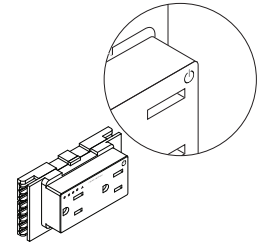

**Controlled receptacle** must be indicated when tying into the building management system. Duplex receptacles have an option for a factory permanent, pad stamp power icon symbol with the word controlled per compliance with the Energy Code.



# 2" x 2" Power and Cable Pole

► Specifying, pages 197

**Junction box**, at the top of the power pole, encloses the hardwired connection to the building's electrical service.

**Power poles** bring building power from the ceiling to the powerways in the base cavity of panels. They can also be used to run cables into the top cap or into the panel base cavity. All five wiring schematics are available.

**Trim** conceals powerway and cables routed to the base of the panel.

**Knockout**

**The power pole harness** attaches to either end of a powerway.

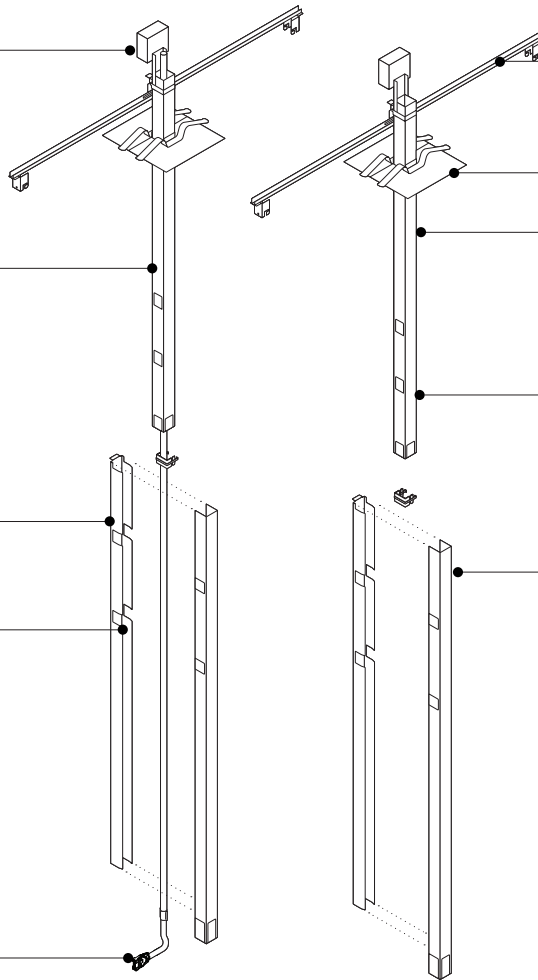

**Hanger bar** secures the top of the pole to the ceiling grid.

**Ceiling trim plate**

**Cable poles** provide a space to route cables from the ceiling to the high top cap or base cavity of a panel.

**Knockouts** allow data distribution in change-of-height conditions.

**Retainer** attaches to the end of a panel with screws that attach below the top cap. Panel remains undamaged so power and cable pole can be removed and relocated later.

**On June 19, 2023, Kick power components** changed design. Power components manufactured before June 19, 2023 are not compatible with power components manufactured after June 19, 2023.

► See *Power Components Transition Details* on page 48.

**All the components in an electrical distribution network** must use the same wiring schematics. Components are color coded and keyed to make it impossible to connect mismatched parts.

### Product Details

**Power and cable poles** accommodate ceiling heights up to 10'4"H.

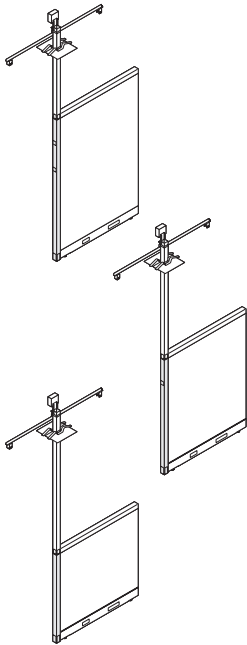

**Height of the pole** must correspond with the height of the panel it is attached to so that the pole will connect under the top cap. Adjacent panels can be lower.

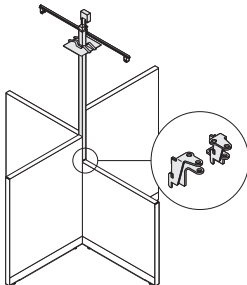

**Power and cable pole packages** ship with one left-hand and one right-hand corner change-of-height connector. A separate change-of-height package may be required in certain X configurations. See assembly direction 93-9504745 for more information.

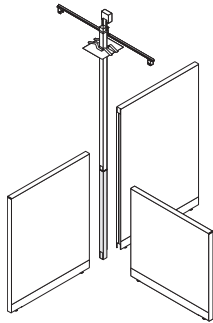

**In T configurations,** height of power and cable pole must correspond to the height of the center panel.

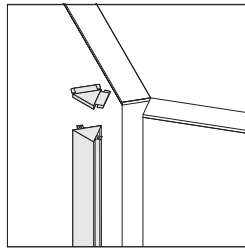

**120° vertical corner trim** is required for all 120° connections. The same 120° vertical corner trim is used for two- and three-way connections and is available with a low end cap only. Both two- and three-way end caps are included with each 120° vertical corner trim package.

▶ Page 189

### Surface Materials

#### Power pole

- Paint

#### Ceiling trim plate

- 4790 Sodium paint

# Base Power-In

**Base power-ins** are field installed and connect the panel electrical system to the building power source. All five wiring schematics are available.  
▶ Specifying, page 199.

**Power-ins** are UL listed and CSA certified. Local electrical codes vary, so consult with your local authority having jurisdiction as they have final say if the products as installed are compliant with local code.

**All the components in an electrical distribution network** must use the same wiring schematic. Components are color coded and keyed to make it impossible to connect mismatched parts. Building power source can come from the floor, wall, or column.

**On June 19, 2023, Kick power components** changed design. Power components manufactured before June 19, 2023 are not compatible with power components manufactured after June 19, 2023.  
▶ See *Power Components Transition Details* on page 48.

**Connector on end of base power infeed harness** occupies one receptacle location in power block.

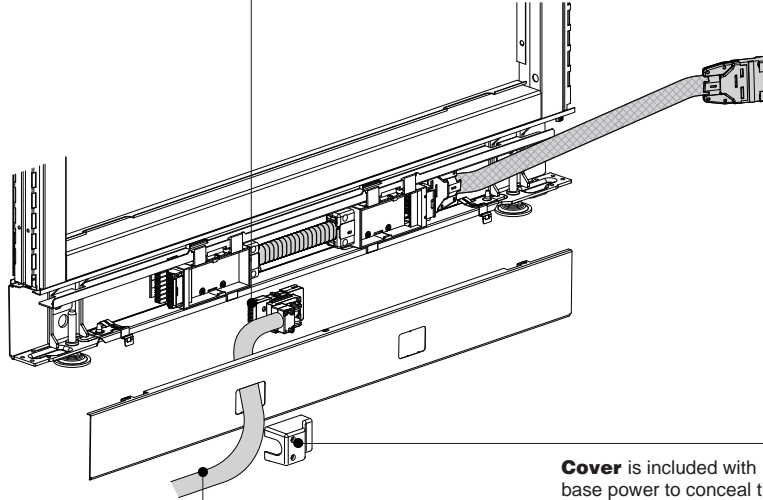

**Flexible harness** secures hardwired connection to building monument. The harness must be back fed through the base trim prior to connection into the building monument.

**Cover** is included with base power to conceal the connection.

## Product Details

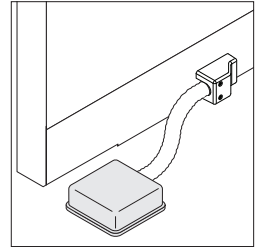

**Power-in** brings power to panel run by connecting to a receptacle location end of the powerway.

**Special requirements** are needed for San Francisco.

▶ See page 199





# Power Components Transition Details

On June 19, 2023, Kick power components changed design. Power components manufactured before June 19, 2023 are not compatible with power components manufactured after June 19, 2023.

The style numbers of power component have changed. The panel style numbers have not changed. Any panel segment ordered with power after June 19, 2023 will include the new power component design.

How power is specified remains unchanged. Power can be optioned on to the panel segment. Powerways can be specified as installed in the factory or installed in the field.

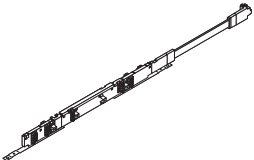
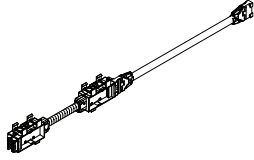
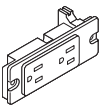
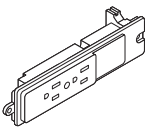
Components included in the design change are powerways, receptacles, base power-ins, and the harness included in the power pole.

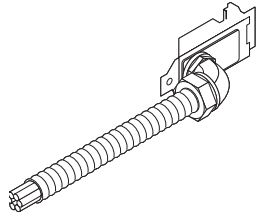
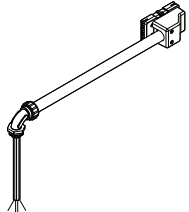
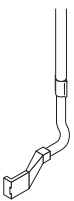
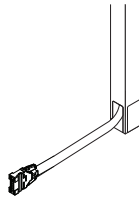
Power before June 19, 2023	Power after June 19, 2023
<b>Powerways</b>	
	
<b>Receptacles</b>	
  <p><b>Standard    Larger</b></p>	
<b>Base Power-Ins</b>	
	
<b>Power Harness in Power Pole</b>	
	

<b>Difference between power components</b>		
<b>What is different</b>	<b>Power before June 19, 2023</b>	<b>Power after June 19, 2023</b>
<b>Connector flag/harness</b>	Mesh connector flag is not removable from the powerway.	Mesh connector flag is removable from the powerway.
<b>Power access in 24" and 30" wide panel segments</b>	24"W and 30"W base covers have a standard-size opening on one side of the panel and larger size opening on the reverse side.	24"W and 30"W base covers have standard-size openings on both sides of the panel.
<b>Receptacle size</b>	Receptacles were available in two sizes– standard and larger.	All receptacles are standard size.
<b>Receptacle cutout locations on base covers</b>	Receptacle location differs before and after June 19, 2023. See details under <i>Receptacle Location Change</i> . Page 51	Receptacle location differs before and after June 19, 2023. See details under <i>Receptacle Location Change</i> . Page 51
<b>Base power-in</b>	Connection at receptacle location does not include an aesthetic cover.	Connection at receptacle location includes an aesthetic cover.
<b>Receptacle connection to powerway</b>	Receptacle connect to powerway with screws.	Receptacle snaps into the powerway without any screws.
<b>Wiring schematics</b>	All five wiring schematics available. Color-coding and keying have changed.	All five wiring schematics available. Color coding and keying have changed.

**Planning with power components manufactured before and after June 19, 2023.**

Power components manufactured before June 19, 2023 can still be used but do not connect to power components manufactured on or after June 19, 2023. The following two approaches can be used when both power systems are used:

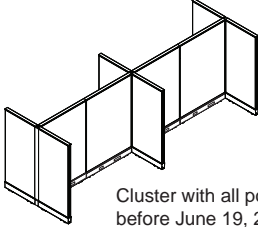

Cluster with all power components manufactured before June 19, 2023.

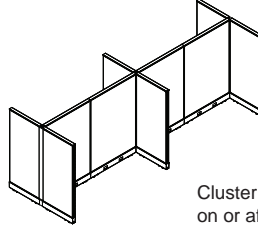

Cluster with all power components manufactured on or after June 19, 2023.

Organize by cluster: power systems can be organized by workstation cluster. Some clusters can use power components manufactured before June 19, 2023 and other clusters can utilize power components manufactured on or after June 19, 2023.

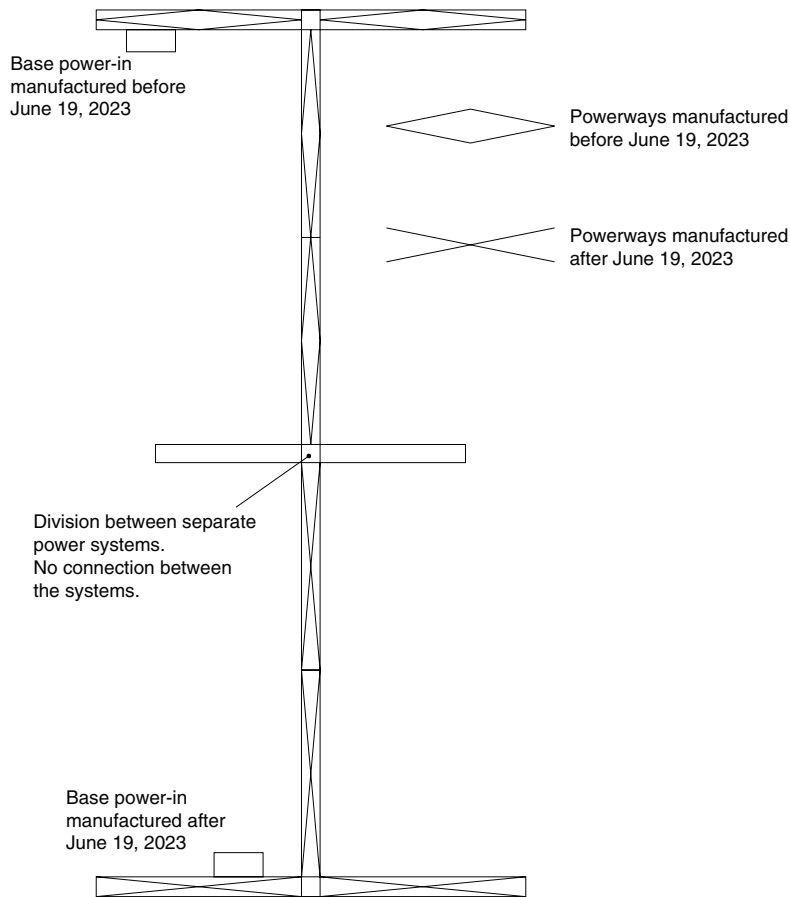

Utilize multiple infeed in a single cluster: a single workstation cluster can use both power systems by utilizing multiple infeeds. Power components manufactured before June 19, 2023 can power part of the workstation and have its infeed and power components manufactured on or after June 19, 2023 can power part of the workstation and have its infeed. Each power system covers part of the workstation and the two systems do not connect to one another.

**Receptacle location change**

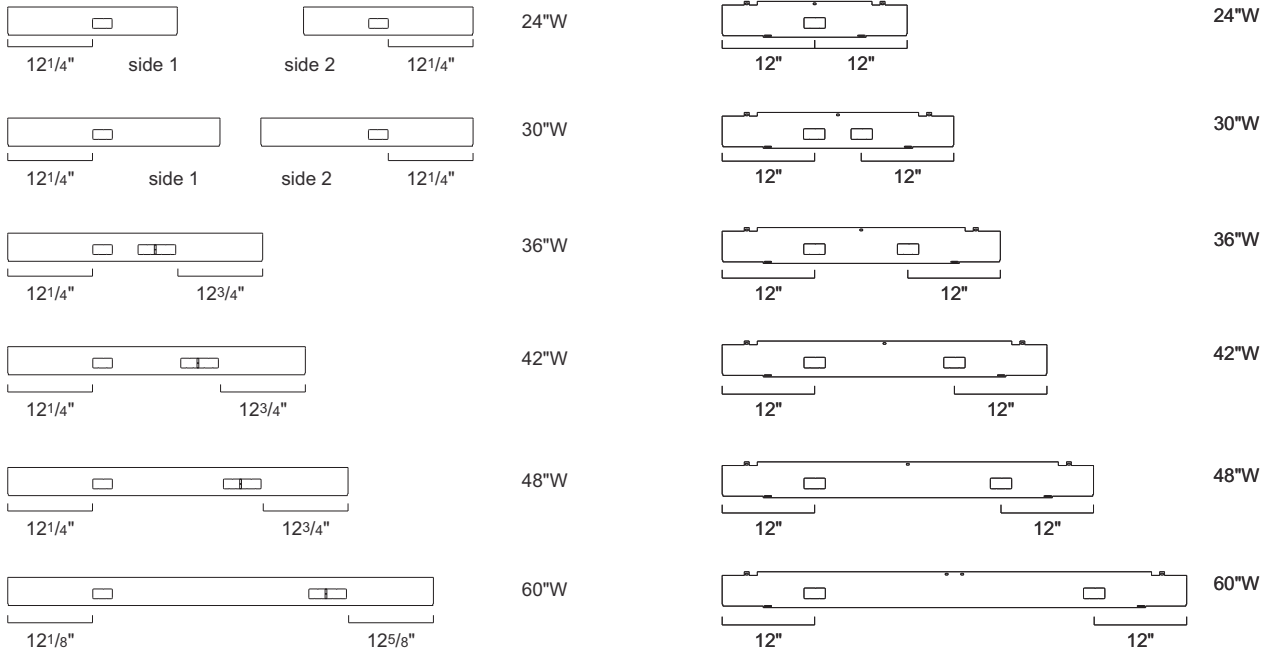

**Receptacle location for base trims manufactured before June 19, 2023**

**Receptacle locations for base trims manufactured after June 19, 2023**

**Status of power components manufactured before June 19, 2023**

Powerways, panel connectors, receptacles, base power-ins, and harnesses included in the power pole manufactured before June 19, 2023 are no longer supported.

Base covers with receptacle cutouts for the receptacle locations of the pre-June 19, 2023 powerways are supported as service parts.

Receptacle knockout fillers for both the pre-June 19, 2023 and post-June 19, 2023 are available as a service part.

The pre-June 19, 2023 wire separator, which supports the powerway in the panel, is available as a service part.

**How to convert a Kick panel manufactured before June 19, 2023 with post June 19, 2023 power components.**

1. Remove all pre-June 19, 2023 power components and the pre-June 19, 2023 wire separator.
2. Order from service parts a post June 19, 2023 powerway and a post June 19, 2023 set of base covers of the appropriate width. Powerways, wire separators, and base covers are not available as style numbers.
3. Add post June 19, 2023 components to base area of the panel frame manufactured before June 19, 2023.

# Worksurface-Height Power and Communication

**Power and communication** can be accessed at or near worksurface height by using panel- or worksurface-mounted receptacles, panel- or worksurface-mounted communication modules, or worksurface-mounted power and communication sphere.

► Pages 200 and 216

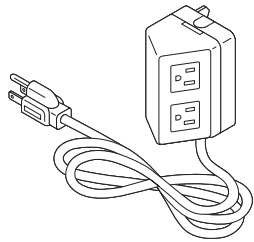

**Panel-mounted receptacle**

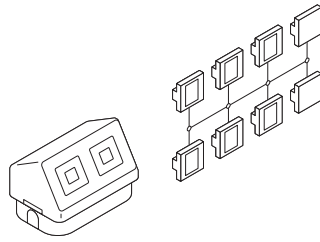

**Worksurface-mounted communication module**

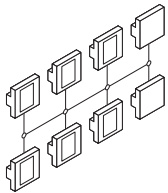

**Panel-mounted communication module**

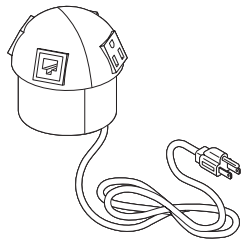

**Worksurface-mounted power and communication sphere**



**Grommet**

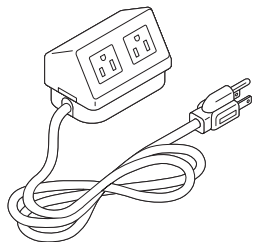

**Worksurface-mounted receptacle**

## Product Details

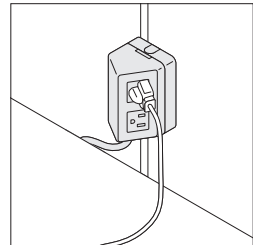

**Panel- and worksurface-mounted receptacles** come in packages of three. Each has a duplex receptacle, a nine-foot cord, and a three-prong plug.

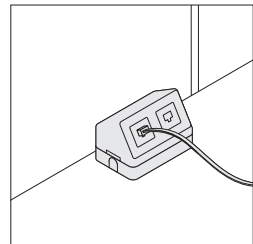

**Panel- and worksurface-mounted communication modules** come in packages of three. Each contains face plates to accommodate customer-supplied voice/data jacks. Comes in package of three.

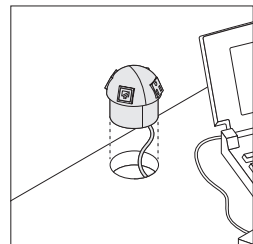

**Worksurface-mounted power and communication sphere** contains two simplex electrical outlets, face plates to accommodate customer-supplied data jacks, a six-foot cord, and a three-prong plug.

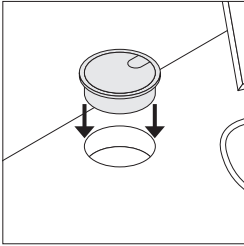

**Grommets** are available in packages of 10 to finish exposed edges of field-installed openings in the worksurface for vertical cable routing. Grommets are black plastic.

**All power and communication products** are available in black plastic only.

### Wiring and Cabling

**Chicago, New York City, and Los Angeles** have special requirements.

#### Underwriters

**Laboratory (UL)** listed.

These products have been designed to meet U.S. and Canadian national electrical and energy codes and most local building codes. Local electrical codes vary, so consult with your local authority having jurisdiction as they have final say if the products as installed are compliant with local code.

Consult with a qualified electrician or electrical engineer for proper installation of all electrical equipment.



---

# Understanding TS Series Worksurfaces and Supports



**Statement of Line** **56**



**TS Series Worksurfaces** **62**

**TS Series Worksurface Supports** **66**

**Freestanding Guidelines** **68**

# Statement of Line

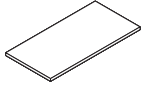

Understanding  
 ▶ Page 62  
 Specifying  
 ▶ Page 202

## TS Series Straight Worksurfaces

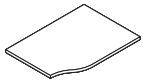
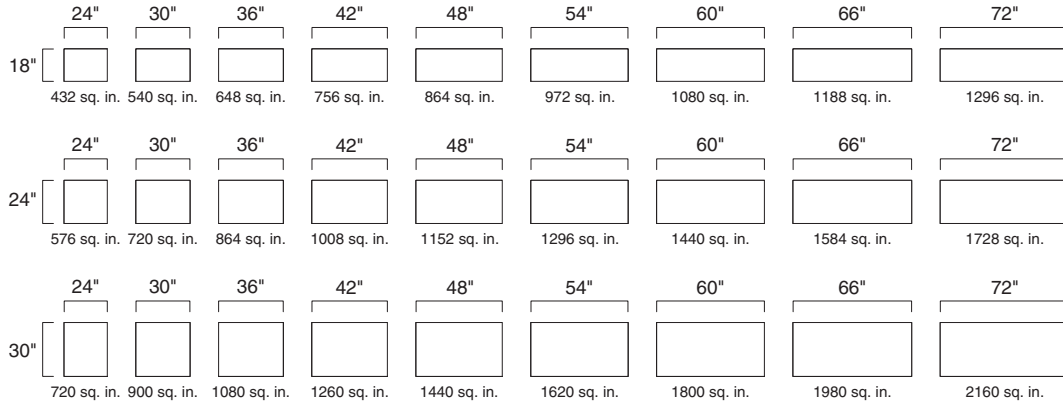

Understanding  
 ▶ Page 62  
 Specifying  
 ▶ Page 203

## TS Series Transition Worksurfaces

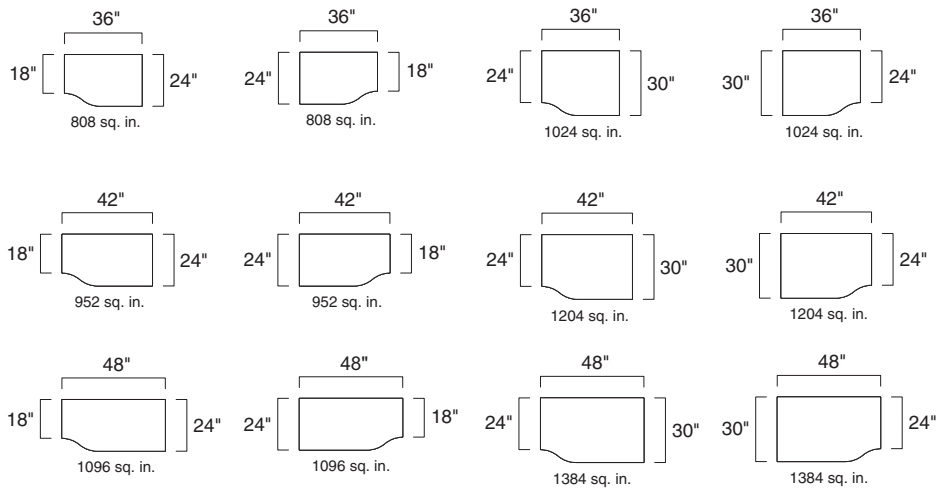

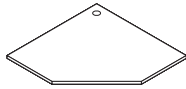

Understanding  
 ▶ Page 62  
 Specifying  
 ▶ Page 204

### TS Series Straight Corner Worksurfaces

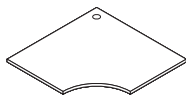
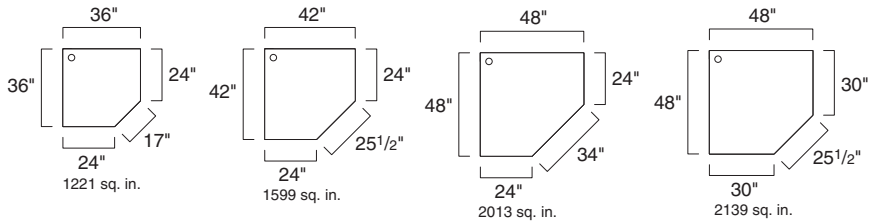

Understanding  
 ▶ Page 62  
 Specifying  
 ▶ Page 205

### TS Series Curved Corner Worksurfaces

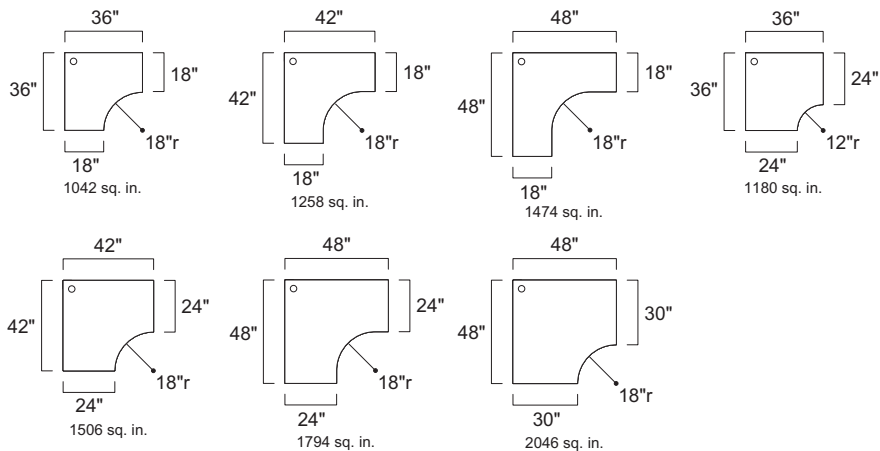

TS Series Worksurfaces

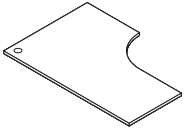

Understanding  
 ▶ Page 62  
 Specifying  
 ▶ Pages 206-207

**TS Series Extended Curved Corner Worksurfaces\***

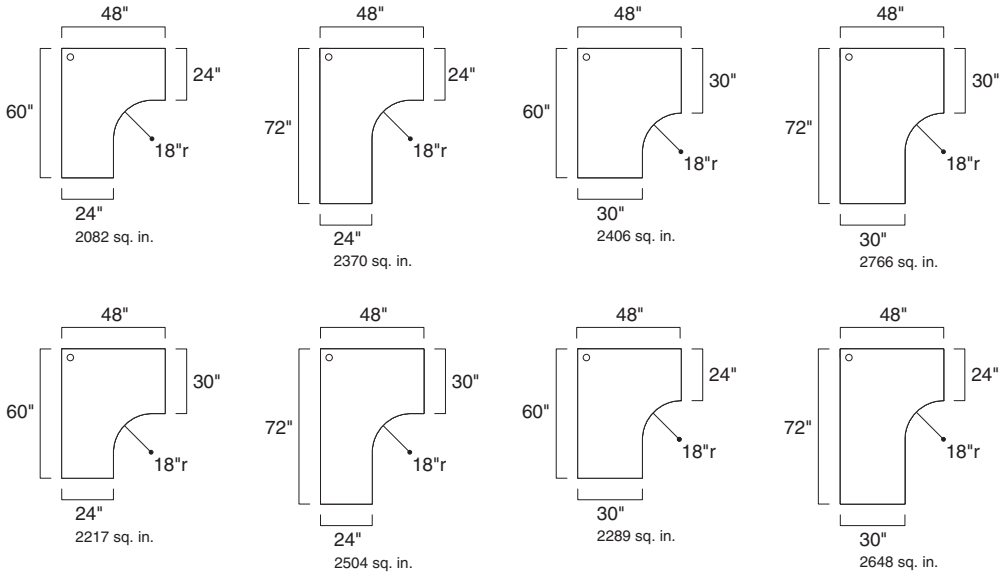

\* Left-hand is shown. Right-hand is also available.

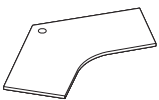

Understanding  
 ▶ Page 62  
 Specifying  
 ▶ Page 208

**TS Series 120° Corner Worksurfaces**

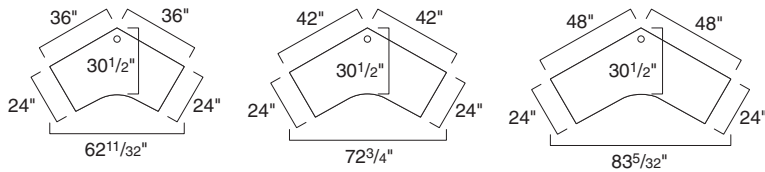

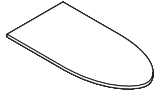

Understanding  
▶ Page 62  
Specifying  
▶ Page 209

### TS Series Peninsula Worksurfaces

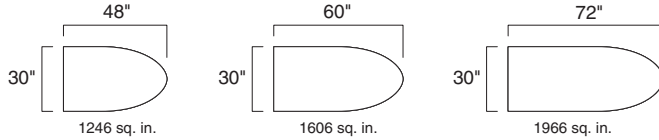

Understanding  
▶ Page 62  
Specifying  
▶ Page 210

### TS Series Angled Peninsula Worksurfaces

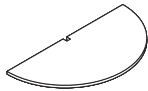
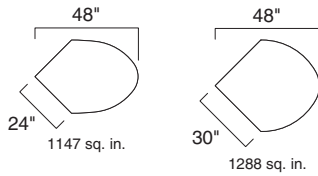

Understanding  
▶ Page 62  
Specifying  
▶ Page 211

### TS Series Spanner Worksurfaces

#### Spanner Worksurfaces for Use with 2" Kick Panels

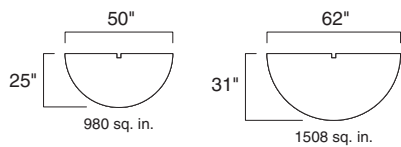

#### Spanner Worksurfaces for Use with 3" Panels

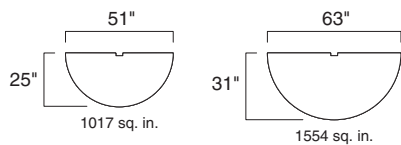

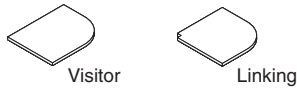

Understanding  
▶ Page 62  
Specifying  
▶ Page 212

## TS Series Visitor and Linking Worksurfaces

### Visitor Worksurfaces For Use With 2" Kick Panels

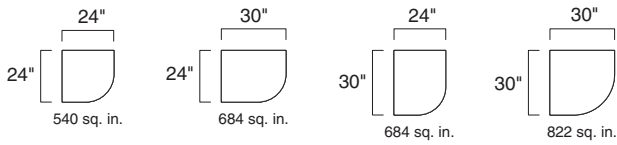

### Linking Worksurfaces For Use With 2" Kick Panels

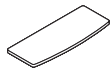
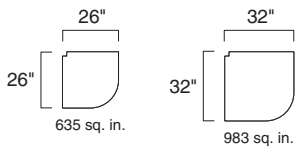

Understanding  
▶ Page 62  
Specifying  
▶ Page 213

## TS Series Transaction Worksurfaces

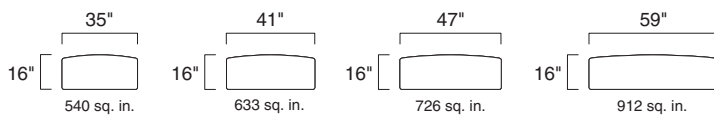



# TS Series Worksurfaces

**Worksurface** has a wood core with laminate top and plastic edge band. Low-Pressure Laminates are available. Plastic edge band color is selectable.

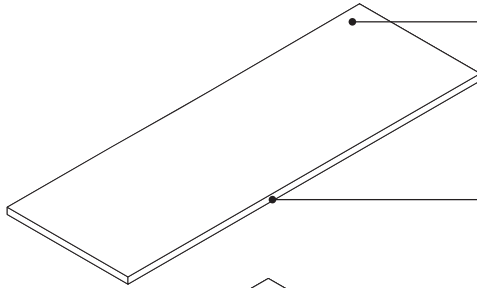

**Full-depth worksurfaces** fit flush against panels.

**Front (user's) edge** is a plastic edge band with a 3 mm radius. Back and side edges are flat.

**Grommet** is standard on corner worksurfaces only. Field-installed grommet requires a 3" diameter hole in the worksurface.

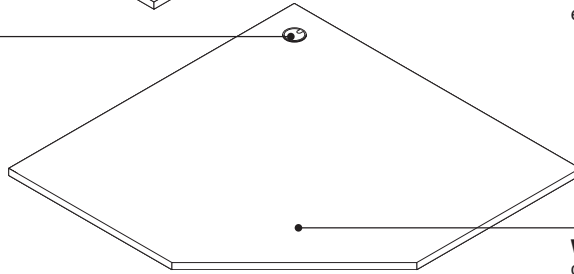

**Worksurface** has a wood core with a Low-Pressure Laminate surface and is 1<sup>3</sup>/<sub>16</sub>" thick.

## Product Details

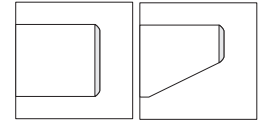

3 mm edge profile      Knife edge profile

**PVC-free, 3 mm edge profiles** are proprietary polyolefin blend for all solid colors and seven woodgrain finishes. Matching 1 mm side and back edges are also PVC-free. See surface material listing in this book for specific PVC-free availability.

**Edge profile finishes** are specified separately from laminate color.

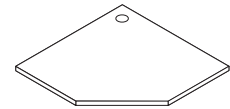

**Corner bracket** is included to connect the back corner of worksurface to panels.

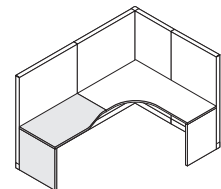

**30" D straight and transition cantilevered worksurfaces** require additional floor support along the front edge, such as a pedestal, end panel, post leg, side support bracket, or an adjacent return worksurface.

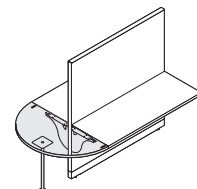

**Spanner worksurfaces** with 3" notch accommodate Kick panels. Legs and cantilevers or column and cantilevers must be used for support.

## Edge Profiles

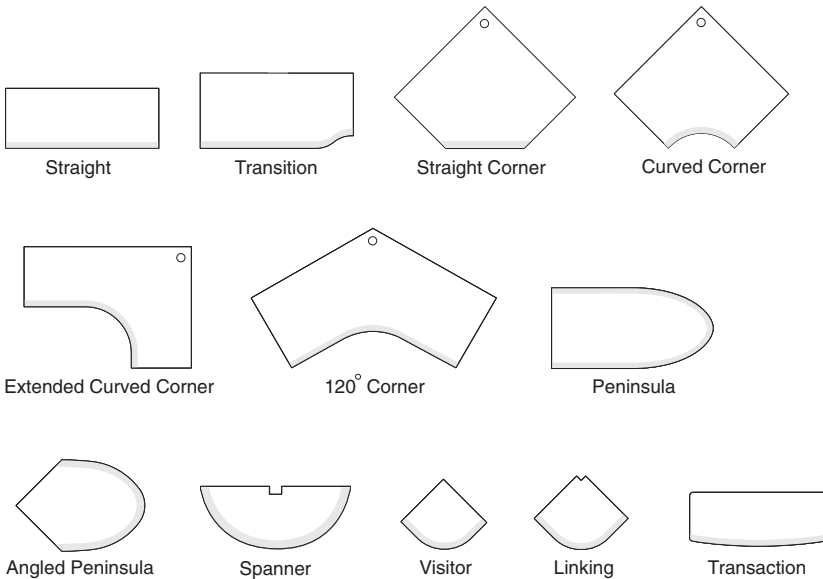

**Edge Profile** is applied to front (user's) edge only.

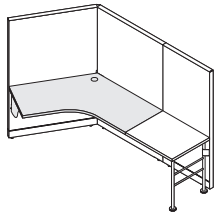

**120° Worksurface**

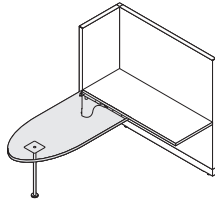

**Peninsula**

**Bullet peninsula, angled peninsula, and jetty worksurfaces** can be supported two ways:

- With a cantilever, a center support panel, and a column
- With a cantilever, a side support bracket, and two post legs

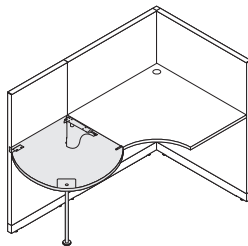

**Angled Peninsula**

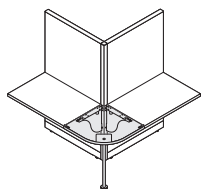

**Linking worksurfaces** with 3" notch accommodate Kick panels. One leg and two cantilevers must be used to support linking worksurfaces.

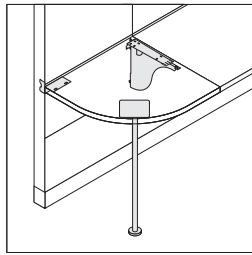

**Visitor worksurfaces** must be supported by a cantilever, a side support bracket, and a post leg.

**Connections**

**Supports** are ordered separately and installed in the field. The following supports are available for use with Kick worksurfaces:

- Post leg
- H-leg
- Cantilever with tie plate
- Side support brackets
- Tie plates
- In-line support plate
- Reinforcing channel
- On-module end panel



Post leg

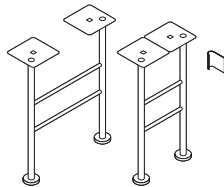

H-leg with bracket

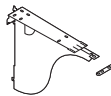

Cantilever with tie plate



Side support brackets Tie plates



In-line support plate

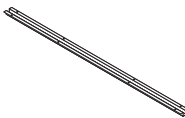

Reinforcing channel

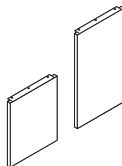

End panels—standard height and standing height

**Cantilever** with tie plate works in left-hand, right-hand, or shared applications.

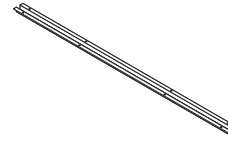

**Worksurface spans greater than 54"** require additional support of a cantilever, pedestal, intermediate support, or leg. Exception; worksurfaces can span up to 60" in heavy load applications and up to 72" in light load applications if a reinforcing channel is used. Reinforcing channel must be specified separately.

▶ Page 263

**Surface Materials**

**Low-Pressure Laminate Worksurfaces**

- Laminate
- ▶ See *Surface Materials Reference Manual*.
- Open Line laminate (option)  
A program including non-Steelcase laminates which are suitable for use on Steelcase products.
- ▶ See *Surface Materials Reference Manual*.

**Front (user's) edge(s)**

- Plastic

**Back and side edges**

- Plastic color default to match user's edge

**Wiring & Cabling**

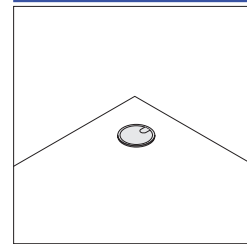

**Grommet** is standard on corner worksurfaces.

**Kick** is available in a wide variety of worksurface shapes. Directional laminate grain direction is shown.

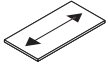

Straight

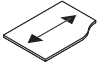

Transition



Straight corner



Curved corner



Left-hand extended curved corner

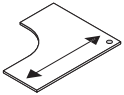

Right-hand extended curved corner

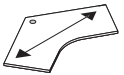

120° Corner

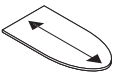

Peninsula



Angled peninsula



Spanner



Visitor



Linking



Transaction

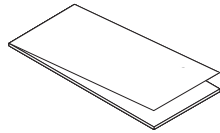

**Low-Pressure Laminates, or LPLs,** are created by dipping decorative crafted paper in melamine resin. The melamine dipped paper is then bonded to a wood core under heat and high-pressure. LPLs are generally suitable for use in lower impact areas. LPLs are generally used in vertical applications as well as tops for workstations and private offices.

### Shipping

**Palletizing** streamlines unloading and staging of worksurfaces. Identical worksurfaces ordered on the same line item are packed on pallets containing 10–20 worksurfaces. Remaining worksurfaces are packed individually in cartons. If palletizing is not desired, order in quantities of nine or less per line item. For maximum unload efficiency, utilize pallet handling equipment at job site whenever possible.



# TS Series Worksurface Supports

**On-module supports** can be used to panel support worksurfaces in various configurations.

► Specifying, page 262

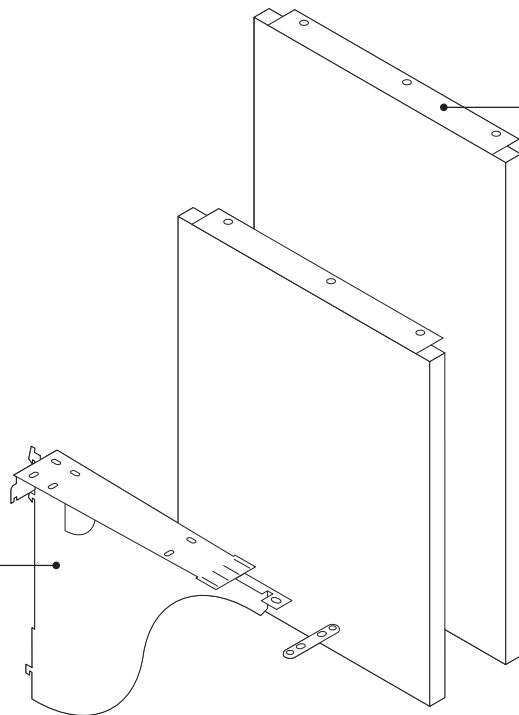

**End panel** can be used to support the end of a work surface at seated height or standing height.

**Cantilever** can be used to panel-support a work surface at any height.

**Side support brackets** can be used to support the ends of straight and corner worksurfaces and to support the back corner of any corner work surface.

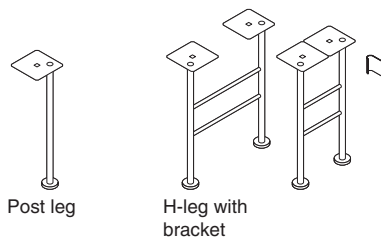
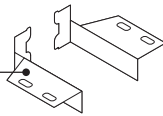

Post leg

H-leg with bracket

## Product Details

**On-module work surface supports** engage the slots in the vertical uprights of Kick panels.

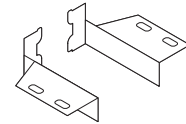

**Side support brackets** support worksurfaces at any height in 1" increments. Brackets ship as a left- and right-hand pair and are ordered separately.

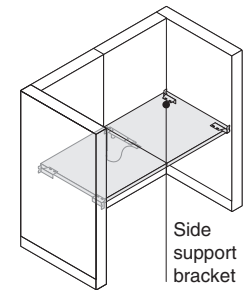

**Side support brackets** can be used to support the end of a work surface that is wrapped by a panel with the same width dimension that matches the work surface depth.

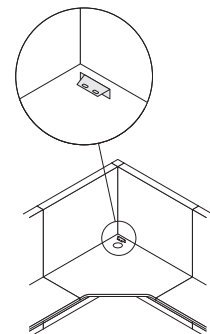

**Single side support bracket** can be used to support the rear corner of corner, extended corner, and 120° corner work surfaces. It is standard with these corner work surfaces.

## Actual Dimensions

	Cantilever	Center support panel	End panel	Post Leg	H-Legs
Height	13"	28½" or 40 <sup>7</sup> / <sub>8</sub> "*	28½" or 40 <sup>7</sup> / <sub>8</sub> "*	28½"	28½"
Depth	16"	11"	23¾" or 29¾"	N.A.	14" or 22¾"
Glide Range	N.A.	1¼"	1¼"	2"	2¾"

\*Height dimensions include the thickness of a work surface.

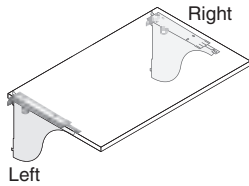

Right

Left

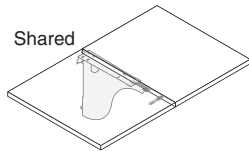

Shared

**Cantilevers** support worksurfaces at any height in 1" increments. Cantilever is non-handed and can be used to support either end of a worksurface, or shared to support two worksurfaces at the same height simultaneously. One tie plate ships with each cantilever.

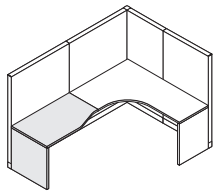

**30°D straight, tapered, and transition cantilevered worksurfaces**

require additional floor support along the front edge, such as a pedestal, end panel, post leg, side support bracket, or an adjacent return worksurface.

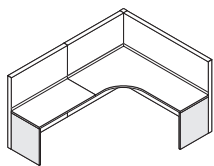

**End panels** can be used to support the end of a worksurface for additional panel stability. Refer to the applicable panel stability guidelines for specific requirements.

**End panels** are available in seated and standing heights, and cannot be used in freestanding applications.

**All panel mounted supports** can be removed and repositioned later without any permanent damage to panels or skins.

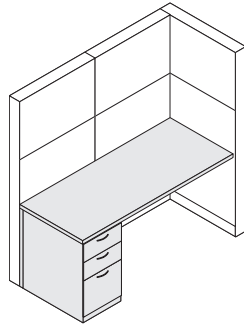

**Pedestals and lateral files** with a filler can be used to support the end of a worksurface in place of an end panel.

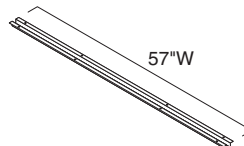

57"W

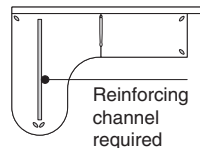

Reinforcing channel required

**Worksurface spans greater than 54"** require additional support of a cantilever, pedestal, intermediate support, or leg. Exception; worksurfaces can span up to 60" in heavy load applications and up to 72" in light load applications if a reinforcing channel is used. Reinforcing channel must be specified separately.  
▶ Specifying, page 263

**Surface Materials**

**Side support bracket and reinforcing channel**

- Black paint only

**Cantilever, center support panel, and end panel**

- Paint

# Freestanding Guidelines

For TS Series Worksurfaces with Legs

The following section on freestanding worksurfaces gives some guidelines to be used with common freestanding configurations. Consult your local dealer or Steelcase representative prior to deviating from these guidelines.

Counterweight packages for storage products are required to ensure product stability.

▶ See page 111 for *Counterweight Requirements for Storage Products*.

There are several ways to support the ends of a freestanding worksurface:

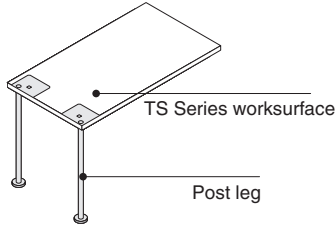

With post legs.

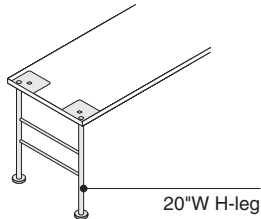

72" max.

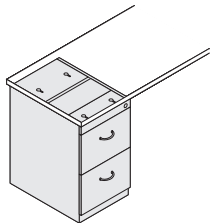

72" max.



With a 22"D or 28"D pedestal.

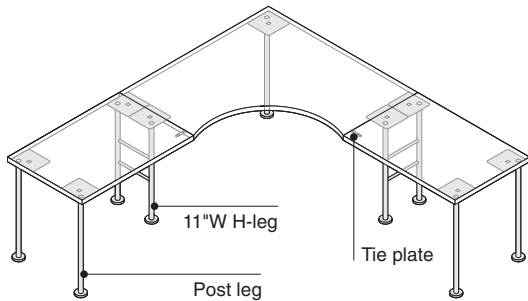

Combined worksurfaces can give each other support when joined with an 11"W H-leg and tie plate.

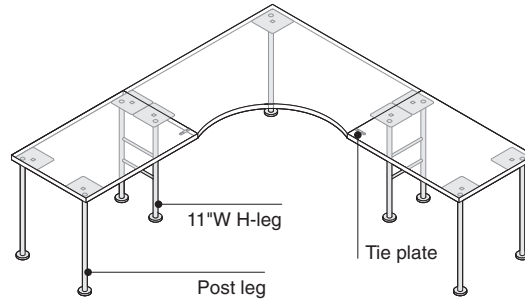

Corner worksurface attached to adjacent worksurfaces requires 11"W H-leg. Tie plate is recommended to align worksurfaces. This application only good for 48"W corner worksurfaces. The 36"W and 42"W corner worksurfaces do not meet ADA requirements.

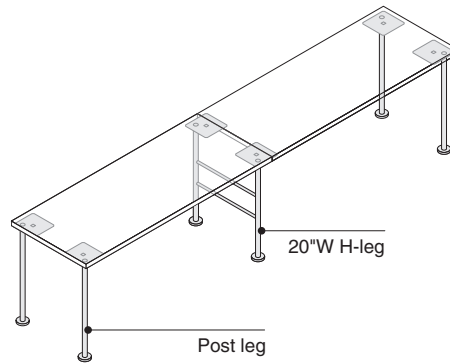

72" max. 72" max.

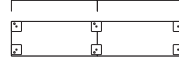

20"W H-leg can support adjacent worksurfaces up to 72"W.

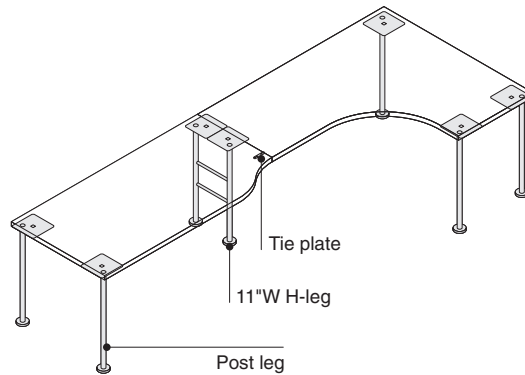

72" max. 72" max.

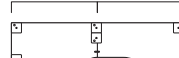

48" max.

11"W H-leg can be used to support a corner worksurface and adjacent worksurfaces up to 72"W.

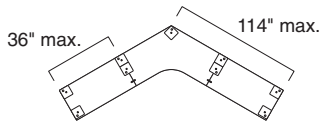
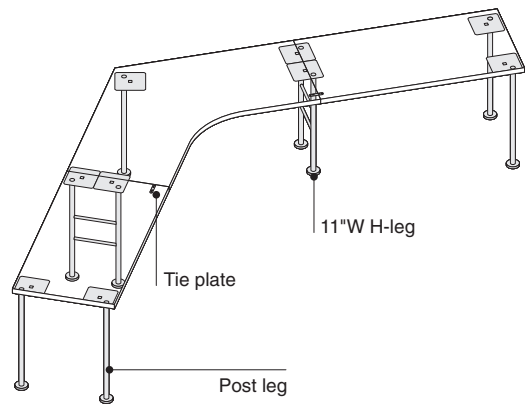

**120° worksurface.**

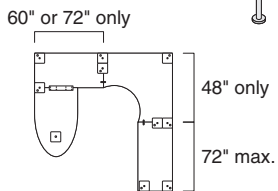
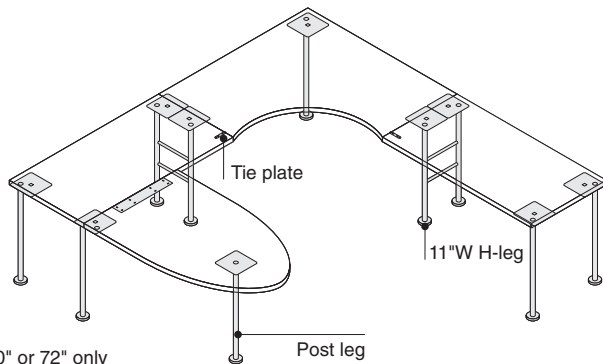

**11" W H-leg** can be used to support a corner worksurface and adjacent worksurfaces up to 72"W.

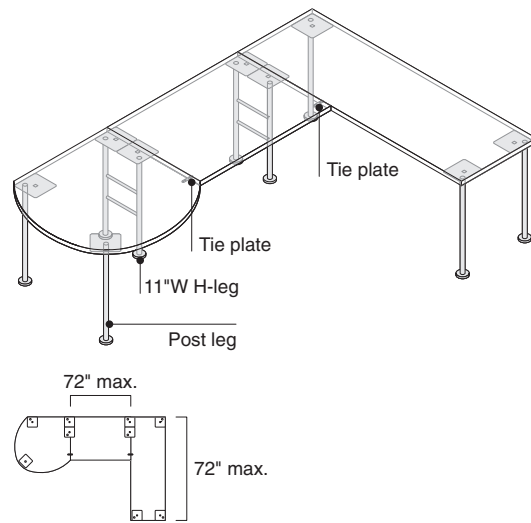

**H-leg** can be used to support adjacent perpendicular worksurfaces up to 72"W.

**Reinforcing channel** (TSATRC39, TSATRC48, TSATRC57, or TSATRC72) is available to add support to worksurfaces that have 60" or more of unsupported kneespace and that are heavily loaded.



---

# Understanding Universal Systems Worksurfaces and Supports

---

	
<b>Statement of Line</b>	<b>72</b>

	
<b>Universal Systems Worksurfaces</b>	<b>86</b>
<b>Worksurface Support Guidelines</b>	<b>90</b>
<b>Universal Systems Worksurfaces with Soft Edge, Power and Data Access Door and Tray</b>	<b>94</b>
<b>Universal Systems Worksurfaces with Power Access Door</b>	<b>98</b>
<b>Universal Panel-Mounted Worksurface Supports</b>	<b>100</b>
<b>Legs and Columns for Universal Systems Worksurfaces</b>	<b>102</b>
<b>Knife Edge Worksurface Application Guidelines</b>	<b>104</b>
<b>Freestanding Guidelines for Universal Systems Worksurfaces with Legs</b>	<b>105</b>
<b>Divisio Side Screen</b>	<b>108</b>

# Statement of Line

All **worksurface sizes and shapes** are available in High-Pressure Laminate with 3 mm edge. Most sizes and shapes are also available in High-Pressure Laminate in wood veneer with square edge. See Specifying pages for details.

**Worksurface dimensions shown** apply to both wood veneer and High-Pressure Laminate versions of each worksurface.

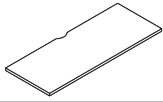

Understanding  
 ▶ Page 86  
 Specifying  
 ▶ Pages 220–230

## Straight Worksurfaces

### With 1/2" Cord Drop



*Tip: Worksurfaces greater than 30" can only be used in free-standing applications.*

*Tip: Modular dimensions displayed, parametric dimensions available in depths from 18" to 120" in 1/16" increments both depth and width.*

### With Full Depth

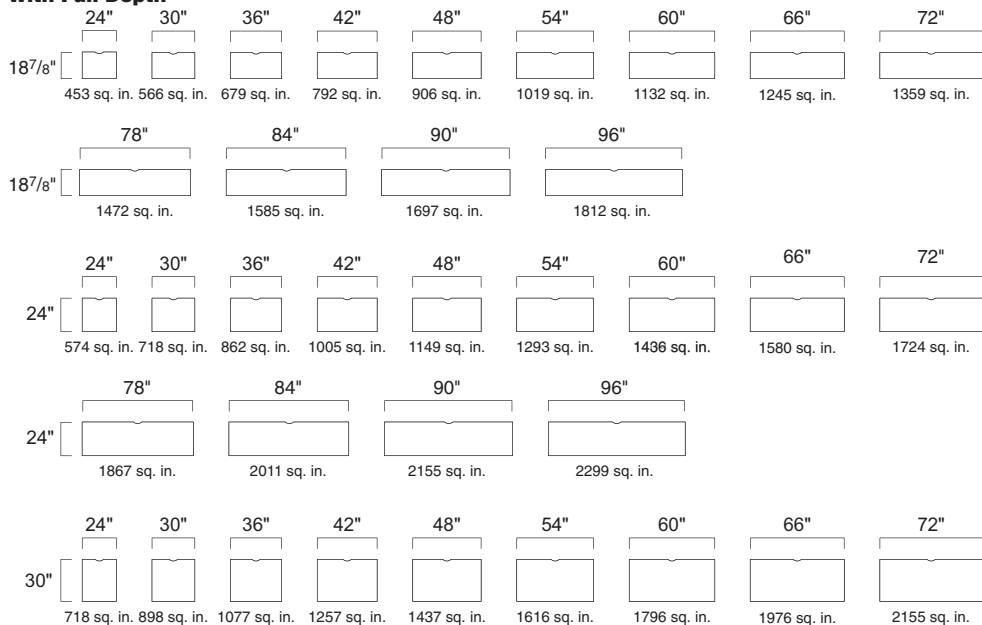

*Tip: Modular dimensions displayed, parametric dimensions available in depths from 18" to 120" in 1/16" increments both depth and width.*

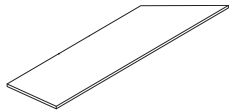

Understanding  
 ▶ Page 86  
 Specifying  
 ▶ Page 234

## Straight 120° Worksurfaces

### With 1/2" Cord Drop

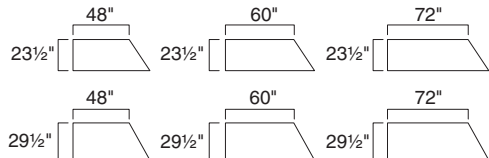

\*Right-hand units shown. Left-hand units available.

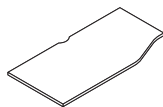

Understanding  
 ▶ Page 86  
 Specifying  
 ▶ Page 236

## Transition Worksurfaces\*

### With 1/2" Cord Drop

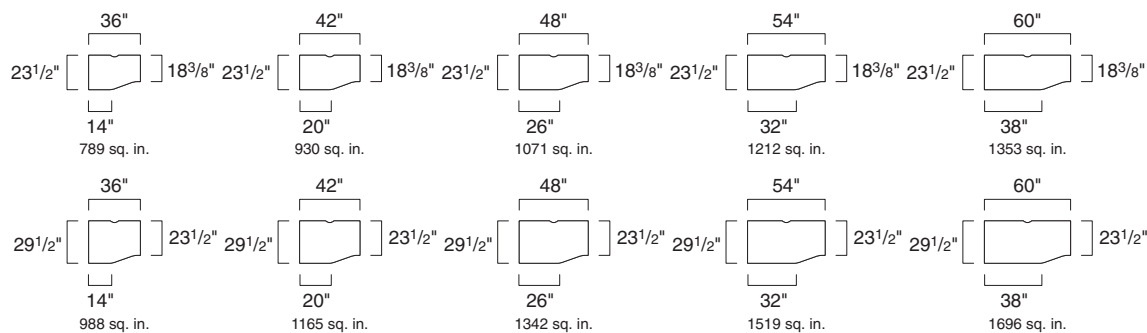

### With Full Depth

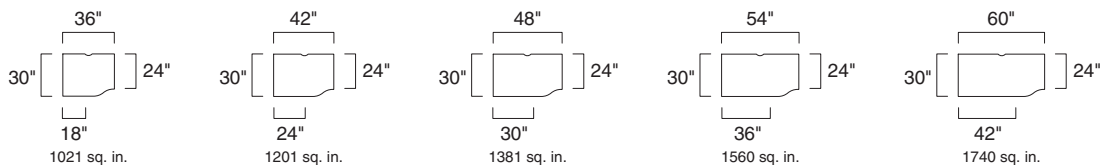

\*Left-hand units shown. Right-hand units available.

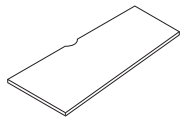

Understanding  
 ▶ Page 86  
 Specifying  
 ▶ Page 238

### Tapered Worksurfaces\*

#### With 1/2" Cord Drop

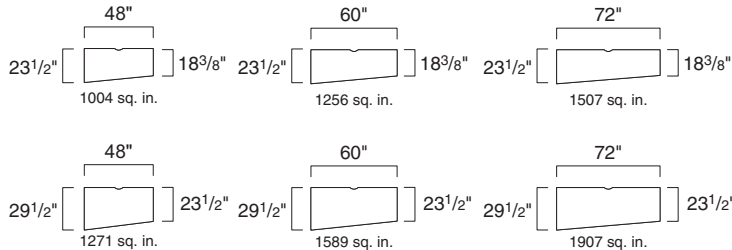

#### With Full Depth

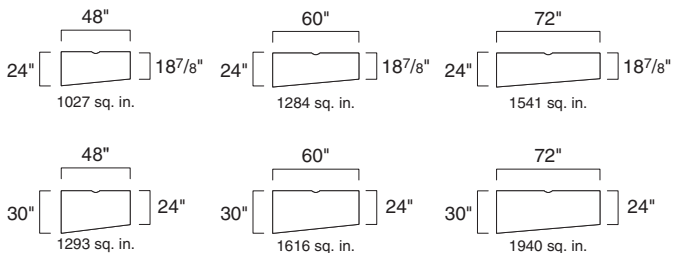

\*Left-hand units shown. Right-hand units available.

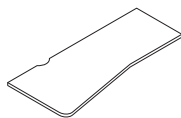

Understanding  
 ▶ Page 86  
 Specifying  
 ▶ Page 240

### Taper-Flat Worksurfaces\*

#### With 1/2" Cord Drop

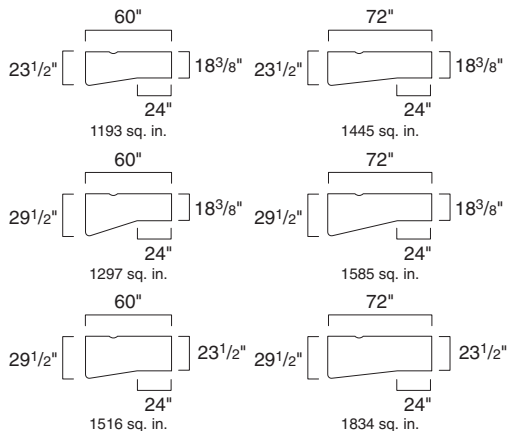

#### With Full Depth

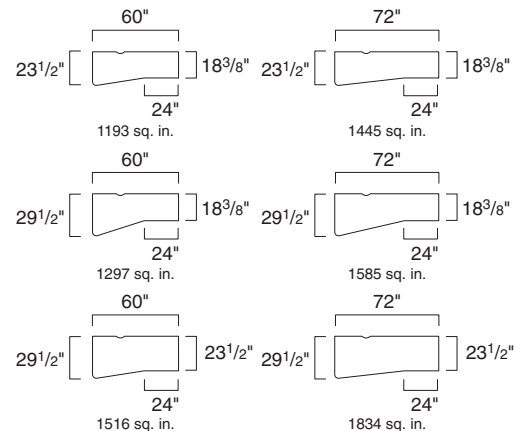

\*Left-hand units shown. Right-hand units available.

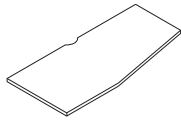

Understanding  
 ▶ Page 86  
 Specifying  
 ▶ Page 241

## Single-Tapered Worksurfaces\*

### With 1/2" Cord Drop

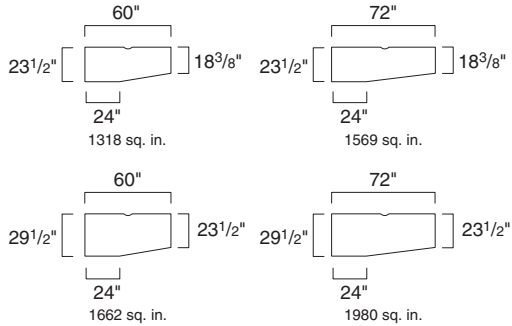

### With Full Depth

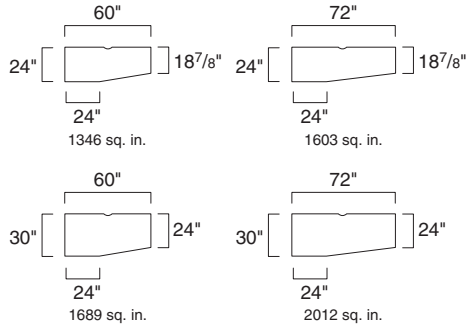

\*Left-hand units shown. Right-hand units available.

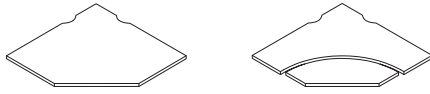

Understanding  
 ▶ Page 86  
 Specifying  
 ▶ Page 242

## Corner, Flat-Front Worksurfaces

### Corner, Flat-Front Worksurfaces With 1/2" Cord Drop

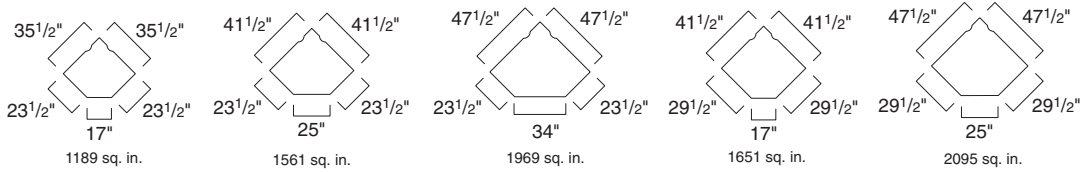

### Dual Corner, Flat-Front Worksurfaces With 1/2" Cord Drop

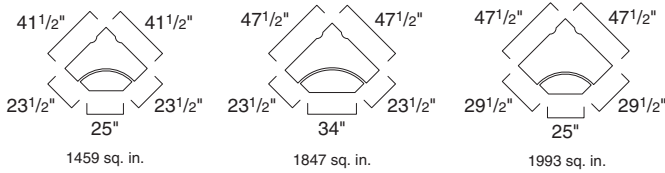

### Corner, Flat-Front Worksurfaces with Full Depth

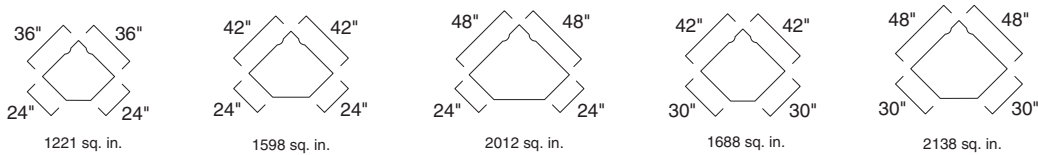

### Corner, Flat-Front Worksurfaces with Full Depth

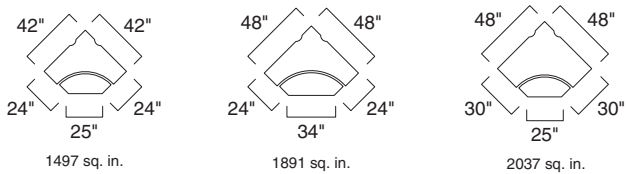



Understanding  
 ▶ Page 86  
 Specifying  
 ▶ Page 244

## Corner, Straight-Front Worksurfaces

### Corner, Straight-Front Worksurfaces With 1/2" Cord Drop

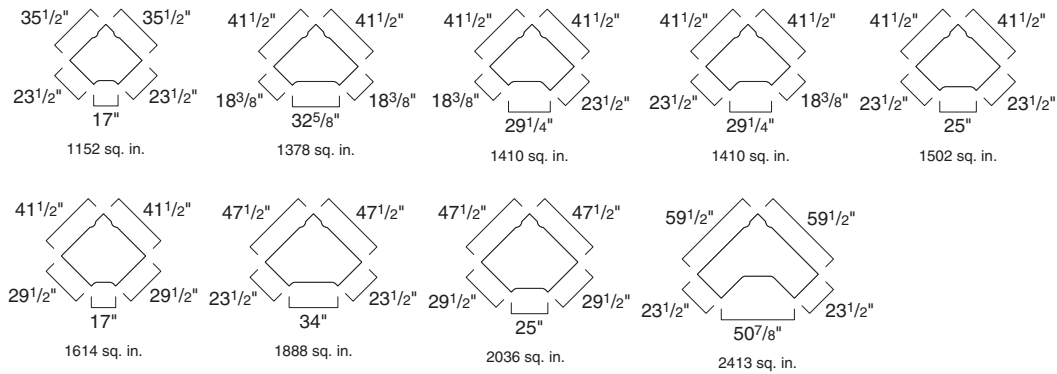



Understanding  
 ▶ Page 86  
 Specifying  
 ▶ Page 245

## Corner, Curved-Front Worksurfaces

### Corner, Flat-Front Worksurfaces With 1/2" Cord Drop

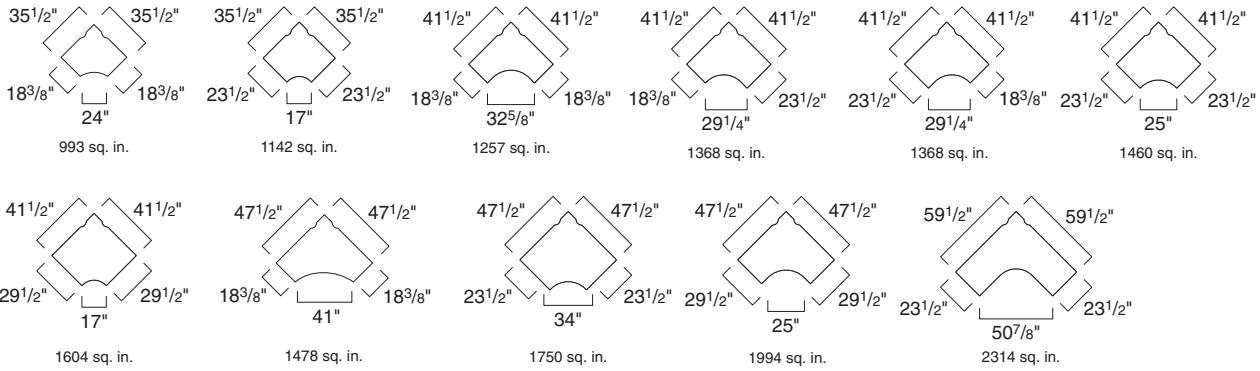

### Corner, Flat-Front Worksurfaces with Full Depth

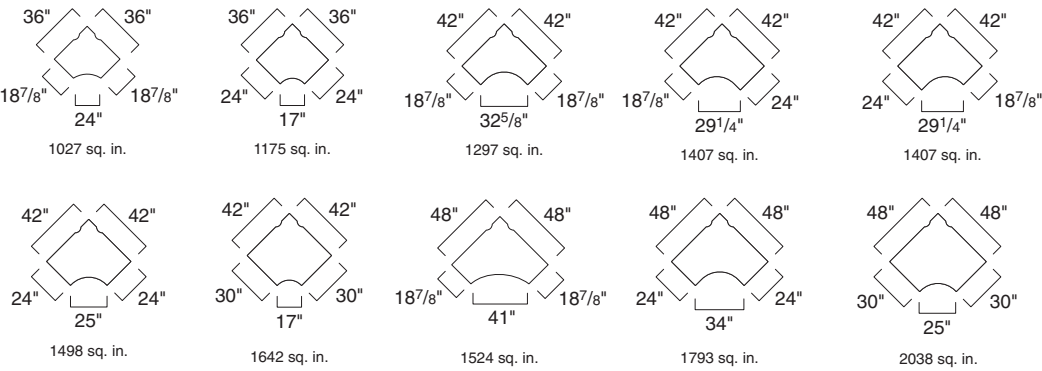

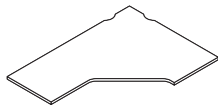

Understanding  
 ▶ Page 86  
 Specifying  
 ▶ Page 246

## Extended Corner, Straight-Front Worksurfaces\*

### Extended Corner, Straight-Front Worksurfaces With 1/2" Cord Drop

\*Left-hand units shown.  
 Right-hand units available.

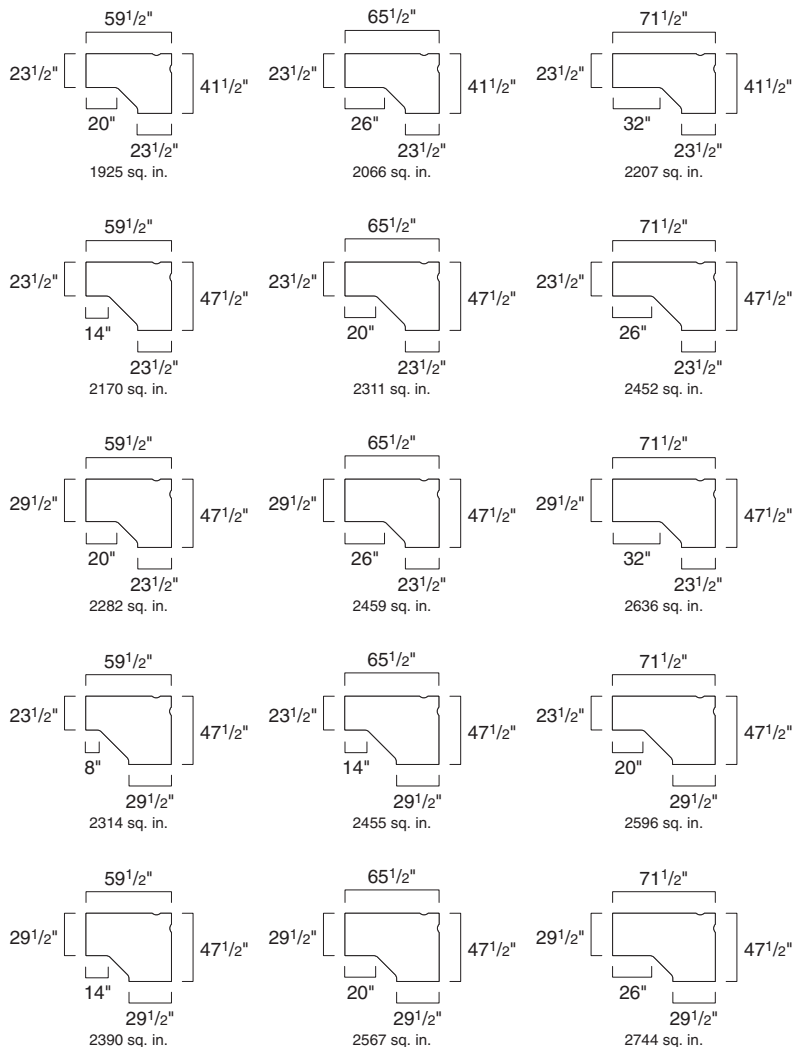



Understanding  
 ▶ Page 86  
 Specifying  
 ▶ Page 248

**Extended Corner, Curved-Front Worksurfaces\***

**With 1/2" Cord Drop**

\*Left-hand units shown.  
 Right-hand units available.

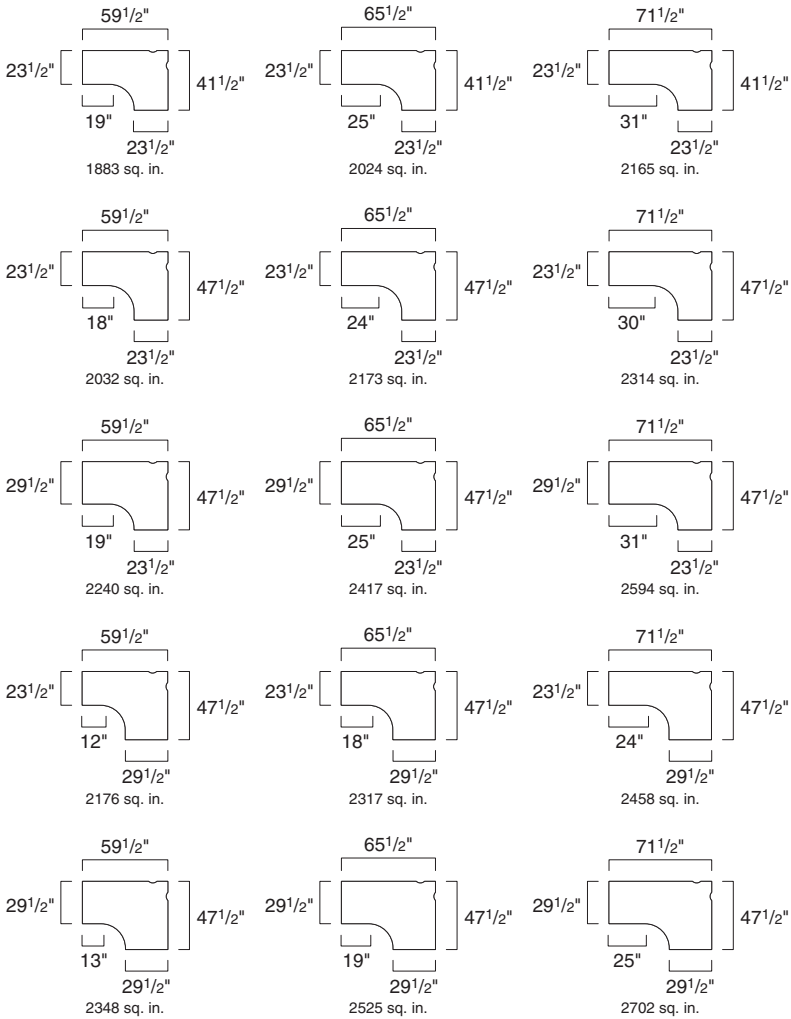

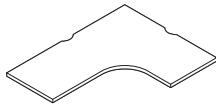

Understanding  
 Page 86  
 Specifying  
 Page 248

## Extended Corner, Curved-Front Worksurfaces\*

### With Full Depth

\*Left-hand units shown.  
 Right-hand units are also available.

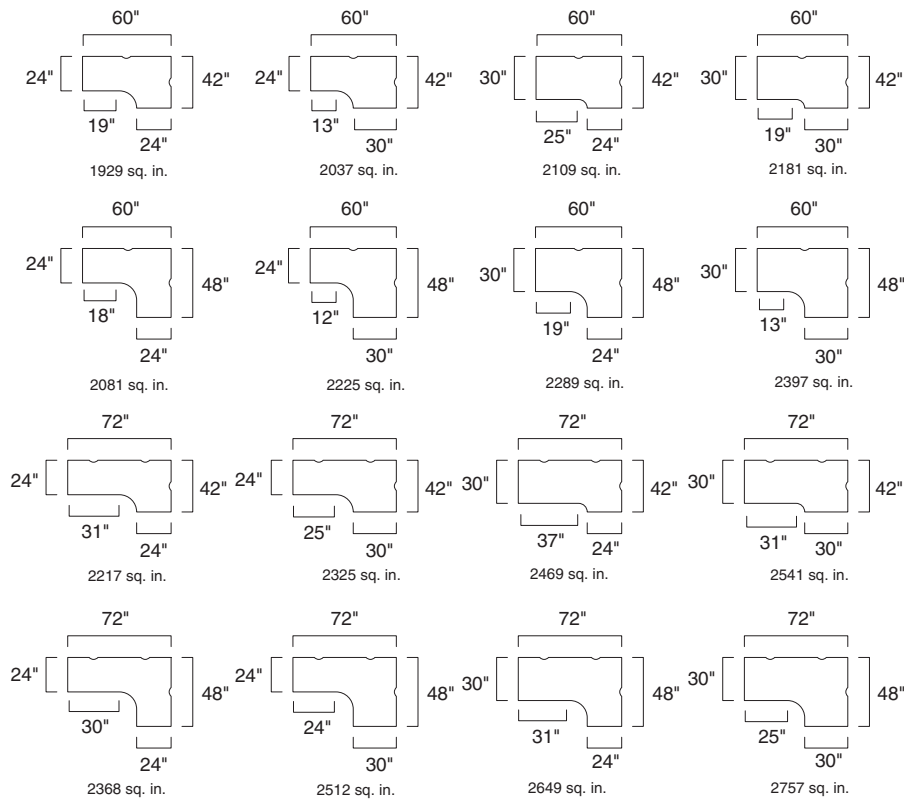



Understanding  
 ▶ Page 86  
 Specifying  
 ▶ Page 250

### Corner, 120° Worksurfaces

#### Corner, 120° Worksurfaces With 1/2" Cord Drop

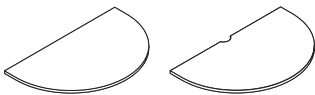
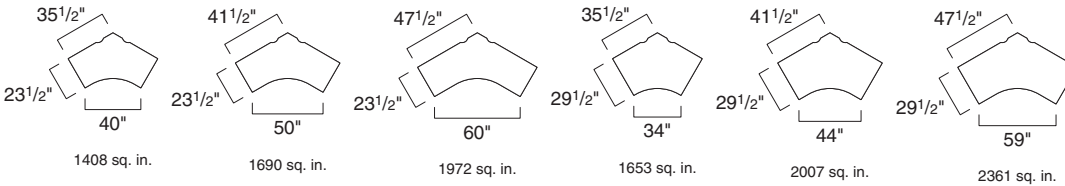

Understanding  
 ▶ Page 86  
 Specifying  
 ▶ Page 251

### Spanner Worksurfaces

#### For Use With 1/2" Cord Drop Worksurfaces

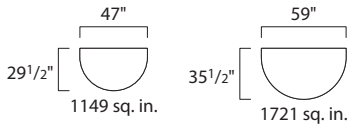

For Freestanding Applications

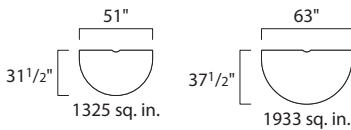

For Panel-Supported Applications

#### For Use With Full Depth Worksurfaces

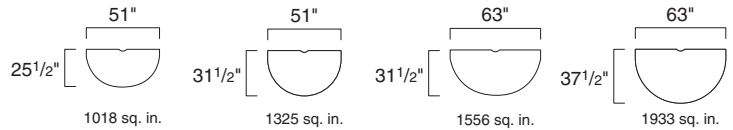
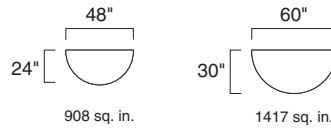

For Freestanding Applications

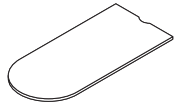

Understanding  
 ▶ Page 86  
 Specifying  
 ▶ Page 252

### Bullet Peninsula Worksurfaces

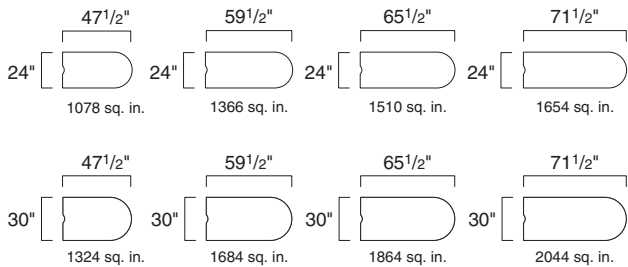

*Tip: The same bullet peninsula work-surfaces can be used with either work-surfaces with 1/2" cord drop, or with full-depth work-surfaces.*



Understanding  
 ▶ Page 86  
 Specifying  
 ▶ Page 253

### Angled Peninsula Worksurfaces

#### With 1/2" Cord Drop

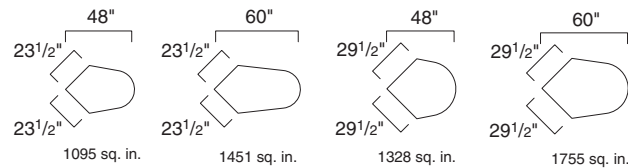

#### With Full Depth

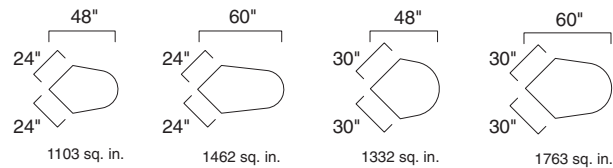



Understanding  
 ▶ Page 86  
 Specifying  
 ▶ Page 254

### Jetty Worksurfaces\*

#### With 1/2" Cord Drop

\*Left-hand units shown.  
 Right-hand units available.

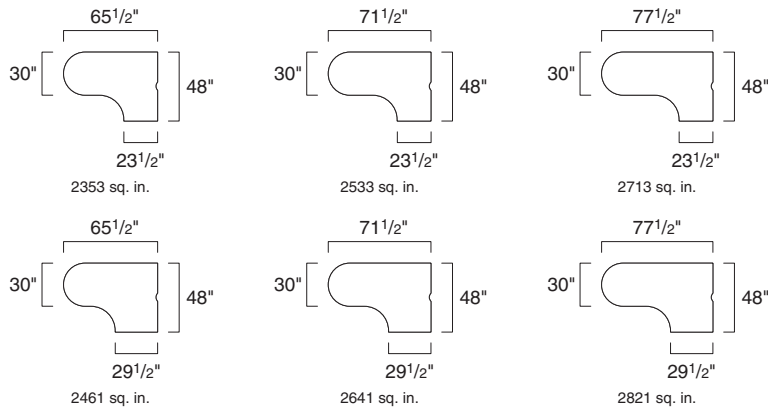

#### With Full Depth

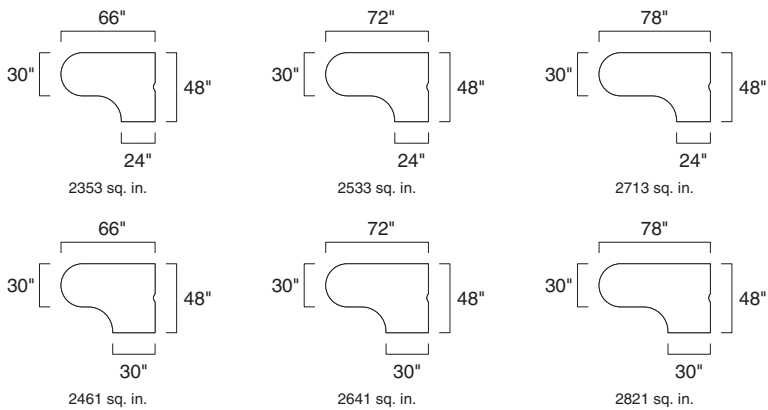

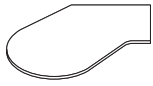

Understanding  
 ▶ Page 86  
 Specifying  
 ▶ Page 256

### Bubble Jetty Worksurfaces\*

#### With 1/2" Cord Drop

\*Left-hand units shown.  
 Right-hand units available.

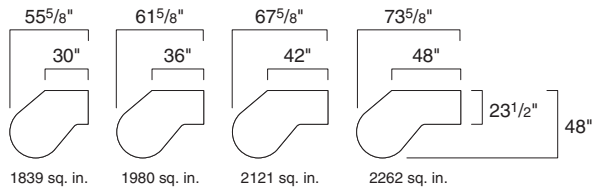

Understanding  
 ▶ Page 86  
 Specifying  
 ▶ Page 258

### Visitor Worksurfaces\*

#### With 1/2" Cord Drop

#### With Full Depth

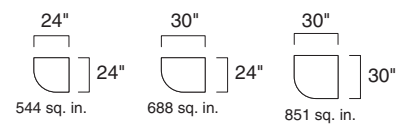
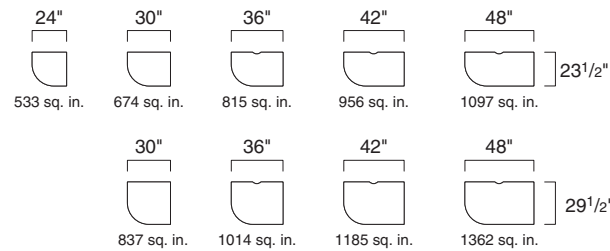

\*Left-hand units shown. Right-hand units available.

Tip: 24"W and 30"W visitor worksurfaces are not available with cable scallops.



Understanding  
 ▶ Page 108  
 Specifying  
 ▶ Page 269

### Divisio Side Screen

29<sup>1</sup>/<sub>2</sub>"D  
 11<sup>5</sup>/<sub>8</sub>"H ●

# Universal Systems Worksurfaces

**Systems worksurfaces— with 1/2" cord drop** feature built-in cable management flexibility, allowing cords to drop below the worksurface at any point along the back edge.

► Specifying Systems Worksurfaces, page 219

**Systems worksurfaces— full depth** feature a tighter fit to panels for a cleaner aesthetic.

**Systems straight worksurfaces with 1/2" cord drop and full depth** are available in a variety of widths and depths in modular and parametric dimensions.

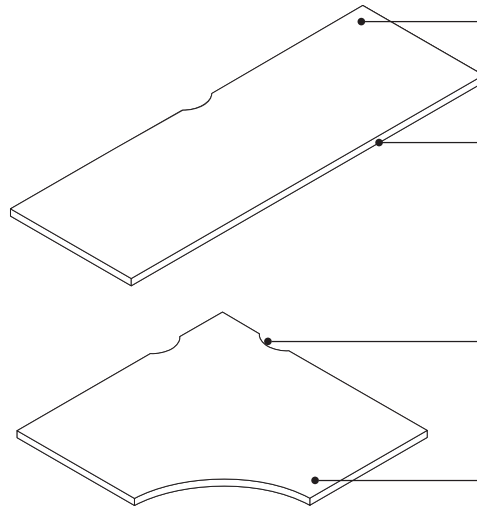

**Full-depth worksurfaces** fit flush against panels. Cords and cables are routed through cable scallops.

**Front (user's) edge** is available in two edge profiles on laminate worksurfaces. Wood veneer worksurfaces have a square (3 mm) edge profile only. Back and side edges are flat.

**Cable scallops** allow cords and plugs to pass behind the worksurface. Cable scallops can be omitted as an option.

**Worksurface** has a wood core with a High-Pressure Laminate or wood veneer surface and is 1 3/16" thick.

## Product Details

### High-Pressure Laminate Worksurfaces

**Front (user's) edge profile** is available in two shapes.

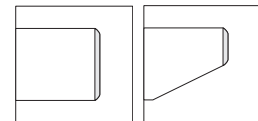

3 mm edge profile      Knife edge profile

**PVC-free, 3 mm edge profiles** are proprietary polyolefin blend for all solid colors and seven woodgrain finishes. Matching 1 mm side and back edges are also PVC-free.

► See surface material listing in this book for specific PVC-free availability.

**Knife edge with 3 mm user edge** is available on straight and tapered systems worksurfaces and on round tables.

**Edge profile finishes** are specified separately from laminate color.

### Wood Veneer Worksurfaces

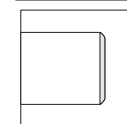

**Front (user's) edge profile** is wood veneer with a square (3 mm) radius. Back edge and edge that joins to adjacent worksurfaces are flat. Wood edge color matches finish specified for worksurface.

**Straight worksurfaces** are available to specify parametrically. The parametric dimensions available are from 18" to 36" deep and from 18" to 120" wide in 1/16" increments both depth and width.

## Edge Profiles

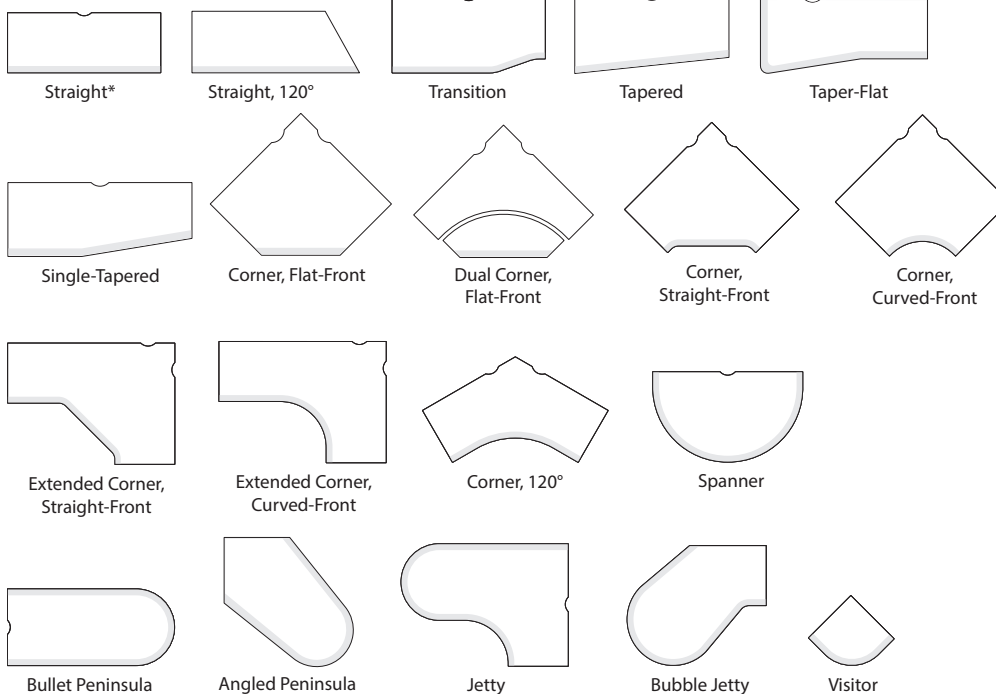

**Edge profile** is applied to front (user's) edge only.

\*Tip: Straight worksurface width is available parametric from 18"W–120"W in 1/16" increments.

\*Tip: Straight worksurface depth can be specified parametric from 18"D–36"D in 1/16" increments.

**Parametric straight worksurfaces** are available in laminate with a 3 mm plastic edge, knife edge, or soft edge options and wood veneer with square edge or soft edge options.

**Parametric straight worksurfaces** have the option to specify a scallop, grommet cutouts, power and data access door and tray cutout, or power access door.

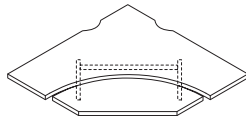

**Dual-worksurfaces** are two pieces - a large monitor surface with a smaller keyboard surface attached. A dual-arm spring mechanism provides superior stability when compared to the single-arm spring mechanism used in worksurfaces with an adjustable keyboard shelf.

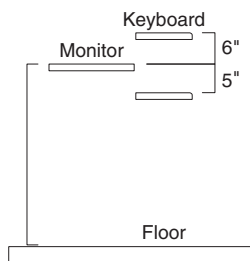

**Keyboard surface on dual worksurface** can be adjusted to positions up to 6" higher or 5" lower than the monitor worksurface.

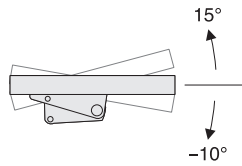

**Keyboard surface** tilts with a range of 25°.

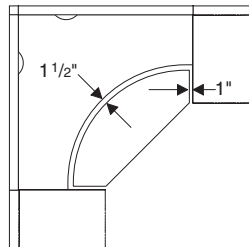

**A 1" gap** separates the sides of the keyboard surface and adjacent worksurfaces. There is also a 1 1/2" space between the keyboard and monitor surfaces.

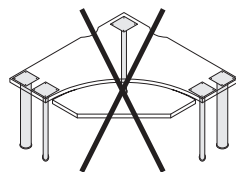

**Dual worksurfaces** cannot be used as a single worksurface. Dual worksurfaces must be tethered to a panel or connected to an adjacent worksurface in a freestanding application.

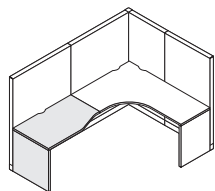

**30°D straight, tapered, and transition cantilevered worksurfaces** require additional floor support along the front edge, such as a pedestal, end panel, post leg, side support bracket, or an adjacent return worksurface.

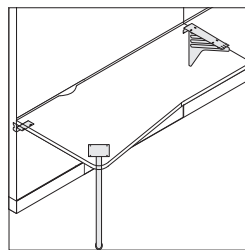
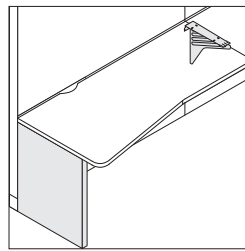

**Taper-flat worksurfaces** can be supported at the larger end with a side support bracket and a post leg. If the larger end is 30"D, a 24"D end panel can also be used.

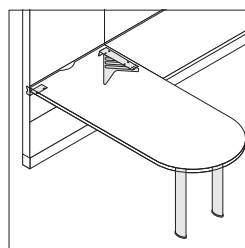
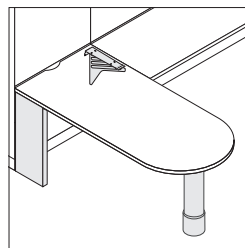

**3 mm edge bullet peninsula, jetty, and bubble jetty worksurfaces** can be supported two ways:

- With a cantilever, a center support panel and a column
- With a cantilever, a side support bracket, and two post legs

In certain applications, a center support panel should not be used because the unfinished top edge of the support panel would be exposed. Use a cantilever, a side support bracket, and two post legs instead. These applications include:

- Angled peninsula with 3 mm edge and 1/2" cord drop

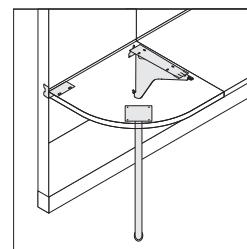
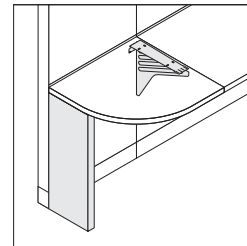

**3 mm edge visitor worksurfaces** must be supported by either a cantilever and a center support panel, or by a cantilever, a side support bracket, and a leg.

## Connections

**Worksurfaces** can be used freestanding or in panel-supported installations.

**Supports** are ordered separately and installed in the field.

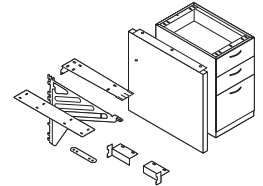

**For panel-supported applications** you can use:

- Side support brackets
- Cantilever with tie plate
- End panel
- Standing-height end panel
- Support plate
- Center support panel with tie plate
- Standing-height center support panel with tie plate
- Columns or legs
- ▶ See page 100 for *Universal Panel-Mounted Systems Worksurface Supports*.
- Universal pedestal with filler
- Universal lateral file with underworksurface lateral file filler.
- ▶ See *Storage Specification Guide*.

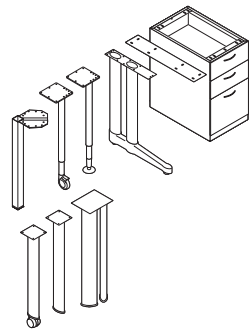

**For leg-based applications** you can use:

- Post legs
  - Double post leg
  - Double post C-leg
  - Support plate
- ▶ See page 102 for *Legs and Columns for Universal Systems Worksurfaces*.  
*Tip: Pedestal can also be used in leg-based freestanding installations.*

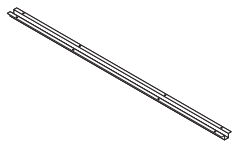

**Worksurface spans greater than 54"** require additional support of a cantilever, pedestal, intermediate support, or leg. Exception; worksurfaces can span up to 60" in heavy load applications and up to 72" in light load applications if a reinforcing channel is used. Reinforcing channel must be specified separately.  
 ▶ Page 263

**Knife edge worksurfaces** require reinforcement channels for spans greater than 48". Use TS7WKSPT39 for 54"W worksurfaces, TS7WKSPT for 60"W and 66"W worksurfaces, and TS7WKSPT72 for 72" worksurfaces.

**Heavy load worksurfaces spanning greater than 60", or all work-surface spans wider than 72"**, require additional support of a cantilever, pedestal, intermediate support, or leg.

**Wiring & Cabling**

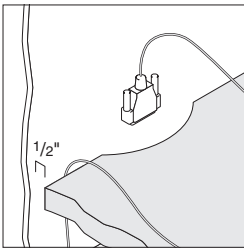

**Worksurface depth** is 1/2" less than nominal and allows cords and cables to pass over at any point. Cable scallops provide space for plugs to pass over the back edge of the worksurface.

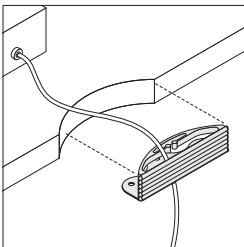

**Cable scallop** allows cord plugs to easily pass below the worksurface. Worksurface wire managers are available to convert cable scallops into grommets in freestanding applications. Wire managers are included with wood veneer worksurfaces. Wire managers for use with laminate worksurface must be ordered separately.

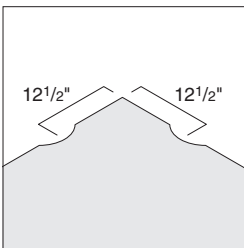

**Corner worksurfaces** have scallops located 12 1/2" from the rear corner of the worksurface to the center of the scallop. Taper-flat worksurfaces have a single scallop located 18 1/2" from the larger end. Scallops are centered on the rear edge of all other worksurfaces that include them.

**Cable scallop** can be omitted for freestanding applications or panel-supported applications where plugs do not need to pass over the back edge of the worksurface.

**Cable management devices** are available to help manage conventional and fiber-optic cables beneath the worksurface.  
 ▶ See *Worksurface Power and Communication*, page 52.

**Parametric straight worksurfaces** have two grommet cutout options. The 2" round grommet cutout option fits the AWAG2 grommet which is specified separately.  
 ▶ See page 261

**The 3" round grommet cutout** option fits the TSAEGROM grommet which is specified separately.  
 ▶ See page 261

**The grommet cutout option** is not available on a work-surface when the power access door option is selected.

**Grommet cutouts in parametric straight work-surfaces** can be specified in the center, the left, or the right sides of the worksurface. Grommet cutouts are available in the below configurations.

Grommet Location on Worksurface	Minimum Worksurface Widths
Center, Right, or Left	All widths
Right and Left	At least 25"W
Right and Center	At least 34"W
Left and Center	At least 34"W
Center, Right, and Left	At least 34"W

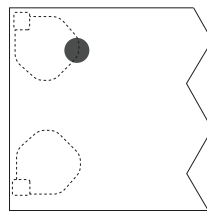

**FrameOne post legs** will interfere with the left or right grommet cutouts on parametric Universal straight worksurfaces.

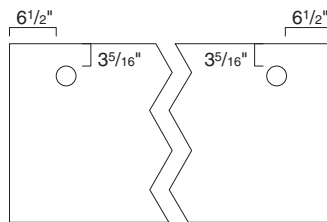

**Grommet cutouts in parametric straight work-surfaces** are located 3 5/16" from the back edge of the work-surface to the back edge of the grommet cutout. Left and right grommet cutouts are located 6 1/2" from the edge of the work-surface to the outside edge of the grommet cutout.

**Surface Materials**

**High-Pressure Laminate Worksurfaces**

- Laminate
- ▶ See *Surface Materials Reference Manual*.
- Open Line laminate (option)  
 A program including non-Steelcase laminates which are suitable for use on Steelcase products.
- ▶ See *Surface Materials Reference Manual*.

**Front (user's) edge(s)**

- Plastic

**Back and side edges**

- Plastic color default to match user's edge

**Wood Veneer Worksurfaces**

- Wood veneer (standard)
- Customiz stain (option)
- Full-fill finish (option)

**Square (3 mm) edge profile**

- Wood veneer to match worksurface

**Front (user's) edge(s)**

- Wood edge band

## Application Topics

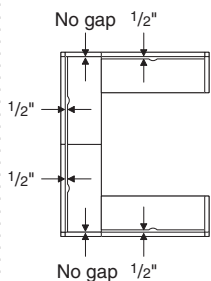
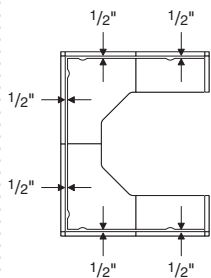

**Full-depth worksurfaces** provide an uninterrupted working surface and are designed to allow traditional corner or L-configuration planning without creating uneven gaps.

**Plan using worksurfaces actual dimensions when panel-wrapping worksurfaces** because worksurface depths and widths vary by type. Straight and transition worksurfaces are full-width to correspond directly with panel width. Corner, extended corner, 120° corner, bullet peninsula, jetty, and visitor worksurfaces are 1/2" less than panel width to allow for a consistent 1/2" cable-management gap when used in combination with straight worksurfaces.

*Tip: To avoid uneven gaps in panel-supported applications, use full-depth worksurfaces to create L-configurations.*

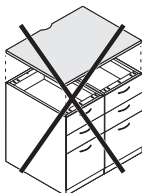

### Do not use a Universal Systems Worksurface

as a top for storage that matches the worksurface width. Universal Systems Worksurfaces are slightly undersized for panel-wrapped applications and will not fit over full-width storage. Use field-installed storage tops for this type of application.

▶ See *Storage Specification Guide*.

**Knife edge worksurfaces** have limitations for support options and application restrictions.

▶ See page 104 for *Knife Edge Worksurface Application Guidelines*.

## Shipping

**Palletizing** streamlines unloading and staging of worksurfaces. Identical worksurfaces ordered on the same line item are packed on pallets containing 5–50 worksurfaces depending on worksurface size. Remaining worksurfaces are packed individually in cartons. If palletizing is not desired, order in quantities of four or less per line item. For maximum unload efficiency, utilize pallet handling equipment at job site whenever possible. Wood veneer worksurfaces cannot be palletized.

# Worksurface Support Guidelines

**Worksurface spans greater than 54"** require a brace or additional support to the floor. Spans greater than 72" wide cannot be supported only by a reinforcing channel, and require additional supports to the floor. Calculate span distance by measuring from edge of one end of worksurface to edge of other end of worksurface.

*Exception: When using pedestals or lateral files to support a worksurface, measure from the inside edge of the storage unit.*

**Worksurfaces** can span up to 60" in heavy load applications and up to 72" in light load applications if a reinforcing channel is used. A light load application is less than 40 pounds placed on a worksurface. Reinforcing channel must be specified separately.

► Page 215

*Exception: Knife edge worksurfaces require support on spans greater than 48"W.*

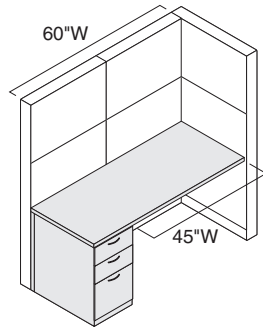

**Reinforcing channel** is not required on worksurfaces with spans less than 54"W.

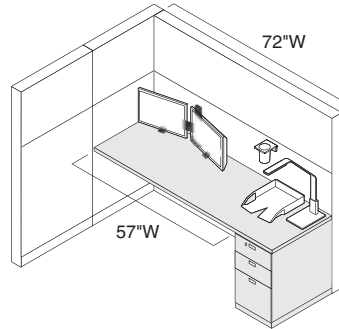

**Lightly loaded applications** typically include a workstation with monitors, lighting, limited organizational tools, and personal items.

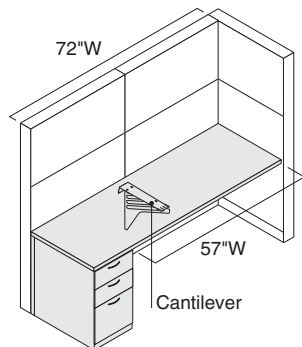

**Reinforcing channel or additional support** is required for worksurfaces with spans greater than 54"W and less than 72"W in light use applications and on worksurfaces with spans greater than 54"W and less than 60"W in heavy load applications.

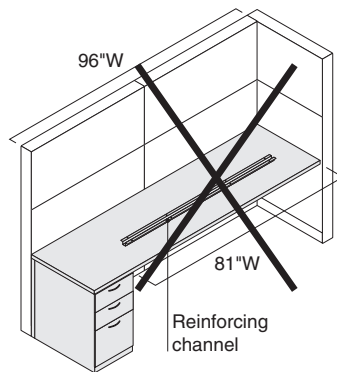

**Worksurface span** cannot be supported solely by a reinforcing channel. Additional to the floor supports are required.

*Tip: Reinforcing channels add 1\"D below the worksurface.*

*Tip: For maximum effectiveness, place the reinforcing channel in the middle of the worksurface span.*

**Calculate span distance** by measuring from edge of one end of worksurface to edge of other end of worksurface. To determine size of reinforcing channel needed, deduct the amount listed in the matrix below from the measured span. Deduction in inches is based on combination of the left-hand and right-hand supports.

Example: 72"W measured span, with application of cantilever for left-hand support and end panel for right-hand support, has a span deduction of 6" for a reinforcing channel size of 66" (72"-6" = 66"). For this application, use reinforcing channel TS7WKSPT66.

Worksurface Span Deductions for Determining Reinforcing Channel Size		Right-Hand Support						
		End Panel	FrameOne Leg	FrameOne Leg-Table Application	Intermediate Support	DBL Post Leg	Cantilever	All other Legs/Supports
Left- Hand Support	End Panel	-6"	-6"	-9"	-9"	-6"	-6"	-6"
	FrameOne Leg	-6"	-6"	-9"	-9"	-6"	-6"	-6"
	FrameOne Leg-Table Application	-9"	-9"	-12"	-12"	-9"	-9"	-9"
	Intermediate Support	-9"	-9"	-12"	-12"	-9"	-9"	-9"
	DBL Post Leg	-6"	-6"	-9"	-9"	-6"	-6"	-6"
	Cantilever	-6"	-6"	-9"	-9"	-6"	-6"	-6"
	All other Legs/Supports	-6"	-6"	-9"	-9"	-6"	-6"	-6"

Note: Not all supports shown work effectively with this panel system. Please check with your field sales representative for clarification and understanding prior to ordering

Reinforcing Channel Sizes		
Style Number	Nominal	Actual
TS7WKSPT39	39"W	39.231"W
TS7WKSPT48	48"W	47.547"W
TS7WKSPT51	51"W	50.547"W
TS7WKSPT54	54"W	53.547"W
TS7WKSPT	57"W	56.547"W
TS7WKSPT60	60"W	59.547"W
TS7WKSPT63	63"W	62.547"W
TS7WKSPT66	66"W	65.547"W
TS7WKSPT72	72"W	71.547"W

Note: If the deducted span distance falls between two reinforcing channel sizes, select the smaller of the two sizes.

#### Reinforcing Channel Size for Straight 120° Worksurfaces

To calculate the reinforcing channel size for a straight 120° worksurface, use the user edge length, subtract 6", and order the next shortest channel. See chart below.

Back Edge Width	Worksurface Depth	User Edge Depth	Reinforcing Channel Size
48"	23½"	61⅙"	54"W
48"	29½"	65⅙"	57"W
60"	23½"	73⅙"	66"W
60"	29½"	77⅙"	66"W
72"	23½"	85⅙"	72"W
72"	29½"	89⅙"	72"W

### Support Requirements for Peninsula Worksurfaces

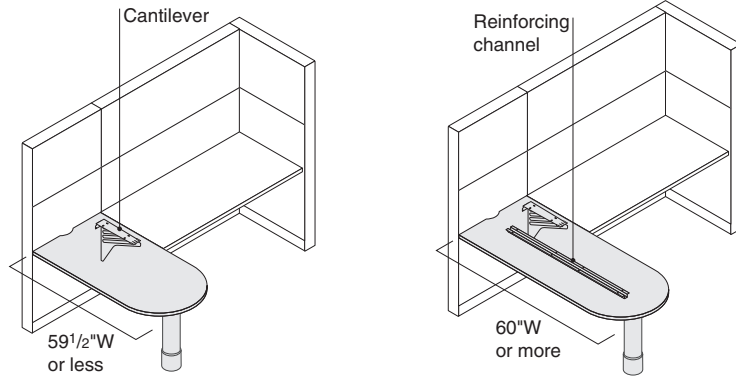

**Peninsula worksurfaces smaller than 60"W** do not require a reinforcing channel. Location of leg or column support, determined by pilot holes, meets the requirements for worksurface support every 54". Sizes 60"W or greater require a reinforcing channel. Determining brace size for peninsula worksurfaces: If worksurface is supported by a single column or legs, subtract 21" from span of worksurface to determine reinforcing channel size. Example: 72"W measured span has a span deduction of 21" for a reinforcing channel size of 51" ( $72" - 21" = 51"$ ). For this application, use reinforcing channel TS7WKSPT51.



# Universal Systems Worksurfaces with Soft Edge, Power and Data Access Door and Tray

**Soft edge** provides a comfortable user experience reducing strain on wrists and forearms.

► Specifying page 228

**Power and data access door and tray** provides desk top access and management of cords.

► Specifying page 260

**Soft edge and power and data access door and tray cutout** are available in modular and parametric straight worksurfaces, both 1/2" cord drop and full depth.

**Cutout** is optional; power and data access door and tray is ordered separately. 24"W cutout is centered near the back of the worksurface.

**Edge** is soft to the touch and flexes to conform to the arm.

**Power and data access door and tray** is available with cord or with modular or hardwire connection.

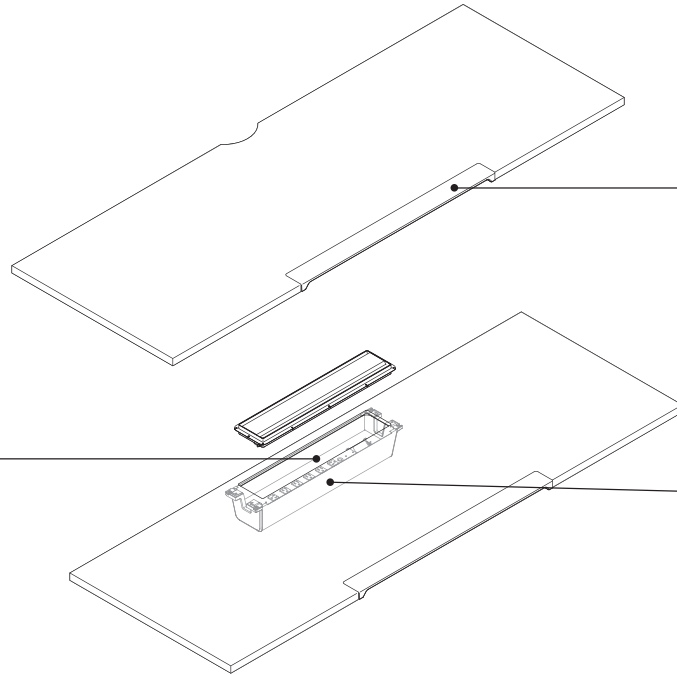

**Soft edge** is 36"W centered on the worksurface; balance of front edge is 3 mm radius. Back and side edges are flat.

**Soft edge and power and data access door and tray** are available on straight and taper Universal Systems Worksurfaces with 1/2" cord drop and full depth.

**Tray** includes six simplex receptacles and cutout for data access.

## Soft Edge, Power and Data Access Door and Tray Worksurface Availability

	48"W	54"W	60"W	65"W	72"W	78"W	84"W	90"W	96"W	102"W	108"W	114"W	120"W
<b>Modular</b>	48"W	54"W	60"W	65"W	72"W	78"W	84"W	90"W	96"W	102"W	108"W	114"W	120"W
<b>Parametric</b>	48"W- 53 <sup>15</sup> / <sub>16</sub> "W	54"W- 59 <sup>15</sup> / <sub>16</sub> "W	60"W- 64 <sup>15</sup> / <sub>16</sub> "W	65"W- 71 <sup>15</sup> / <sub>16</sub> "W	72"W- 77 <sup>15</sup> / <sub>16</sub> "W	78"W- 83 <sup>15</sup> / <sub>16</sub> "W	84"W- 89 <sup>15</sup> / <sub>16</sub> "W	90"W- 95 <sup>15</sup> / <sub>16</sub> "W	96"W- 101 <sup>15</sup> / <sub>16</sub> "W	102"W - 107 <sup>15</sup> / <sub>16</sub> "W	108"W- 113 <sup>15</sup> / <sub>16</sub> "W	114"W- 119 <sup>15</sup> / <sub>16</sub> "W	120"W
<b>Modular Straights</b>	24", 30", and 36"D*	●	●	●	●	●	●	●	●	●	●	●	●
<b>Parametric Straights</b>	24"-36"D*	●	●	●	●	●	●	●	●	●	●	●	●
<b>Modular Tapered</b>	48"W	60"W	72"W										
29 <sup>1</sup> / <sub>2</sub> "D or 30"D to 23 <sup>1</sup> / <sub>2</sub> "D or 24"D	●	●	●										

● Only soft edge, only power & data access door & tray, or both  
\*Tip: Subtract 1/2" for worksurfaces with cord drop.

## Dimensions

	Soft edge	Cutout for Door	Tray (below worksurface)
Width	36"	24"	27 <sup>1</sup> / <sub>8</sub> "
Depth	3"	4 <sup>5</sup> / <sub>8</sub> "	6"
Thickness	1/2" at front	N.A.	N.A.
Height	N.A.	N.A.	4 <sup>3</sup> / <sub>4</sub> "

## Product Details

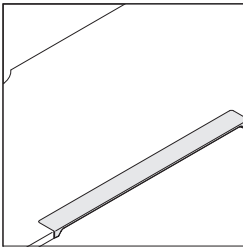

**Soft edge profile** is polyurethane and is available with Bactiblock™ antimicrobial protection.

### High-Pressure Laminate Worksurfaces

**PVC-free, 3 mm edge profiles** are proprietary polyolefin blend for all solid colors and seven woodgrain finishes. Matching 1 mm side and back edges are also PVC-free. See surface material listing in this book for specific PVC-free availability.

**3 mm front edge** is specifiable. Back and side edges match 3 mm front edge.

**Edge profile finish for 3 mm front edge** is specified separately from laminate color.

### Wood Veneer Worksurfaces

**Front (user's) edge profile** is wood veneer with a square (3 mm) radius. Back edge and edge that joins to adjacent worksurfaces are flat. Wood edge color matches finish specified for worksurface.

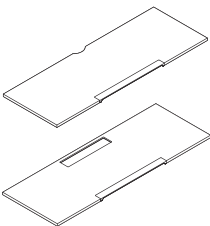

**Scallops** are omitted on worksurface when cutout for power and data access door and tray option is selected.

**Power and data access door and tray cutouts** are 3<sup>7</sup>/<sub>8</sub>" from the back edge of the worksurface and always centered on the width of the worksurface.

**Power and data access door and tray cutouts** are available on worksurfaces 24"D through 36"D.

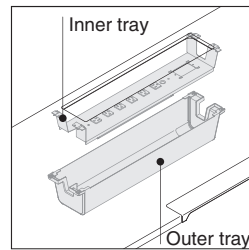

**Inner tray** provides under the surface power and data connections and access and cord management.

**Outer tray** provides cover and management for cord, and/or data cables to and from the panel.

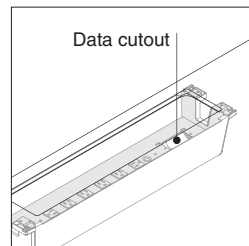

**Data cutout in tray** can accommodate either a single gang or a modular furniture communication faceplate.

**Tray** includes adapter to accommodate modular faceplate.

**Filler packages** are available to fill unused data cutout. Order separately in package of 24.

**Corded tray** includes 10' cord with plug and has an integrated overload circuit breaker. Non-PVC version is available.

**Power and data access door and tray** flips toward the user.

## Connections

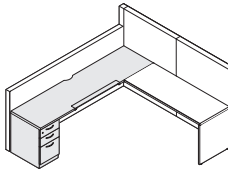

**Fixed storage** can be used with worksurfaces with soft edge but must not encroach the 36" width of the edge.

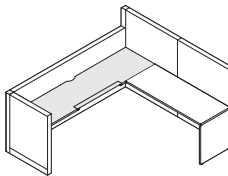

**Worksurfaces** connected perpendicular should not encroach the 36" width of the soft edge.

**Soft edge worksurfaces** are available with the same support options and follow the same application rules as other Universal Systems worksurfaces. *Exception: 48"W worksurface with soft edge cannot have a post leg at the front edge.* ▶ See page 86 for Universal Systems Worksurfaces Understanding.

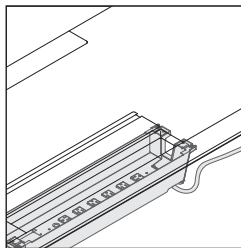

**Access holes in tray** allow power and data to be routed straight back when worksurface is against the panel or routed to the sides when the worksurface is perpendicular to the panel.

**Worksurfaces with power and data access door and tray** are available with the same support options and follow the same application rules as other Universal Systems worksurfaces.

▶ See page 86 for Universal Systems Worksurfaces Understanding.

**Tray with cord and plug** can be used in a free-standing table application.

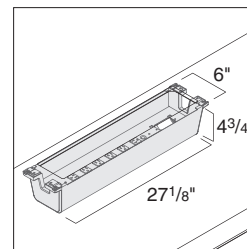

**Height of tray** is 4<sup>3</sup>/<sub>4</sub>" so lower storage height must be accounted for when used adjacent to tray.

**Width of outer tray** is 27<sup>1</sup>/<sub>8</sub>" so adjacent lower storage dimensions must be accounted for on each worksurface width.

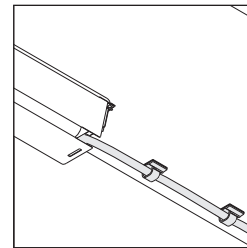

**Tray with cord and plug** includes two cord clips to help manage the cord below the worksurface.

**Soft edge worksurfaces and power and data access door and tray worksurfaces** require reinforcement channel or other support on worksurfaces 60"W or larger.

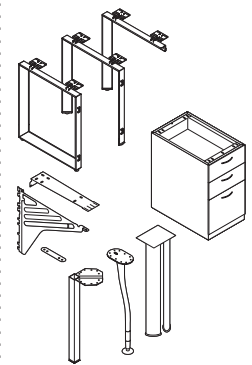

**Worksurfaces** greater than 72"W require additional support such as cantilevers, pedestals, or legs beyond the brace.

## Surface Materials

### High-Pressure Laminate Worksurfaces

- Laminate
- ▶ See *Surface Materials Reference Manual*.

- Open Line laminate (option)

A program including non-Steelcase laminates which are suitable for use on Steelcase products.

- ▶ See *Surface Materials Reference Manual*.

### Soft edge

- 6615 Grey V5 Plastic

### 3 mm front edge

- Plastic

### Back and side edges

- Plastic color default to match 3 mm front edge

### Wood Veneer Worksurfaces

- Wood veneer (standard)
- Customiz stain (option)
- Full-fill finish (option)

### Soft edge

- 6615 Grey V5 Plastic

### Square (3 mm) edge profile

- Wood veneer to match worksurface

### Front (user's) edge(s)

- Wood edge band

### Power and Data Access Door and Tray

#### Door

- Paint
- Anodized aluminum

#### Door bezel

- 6694 Slate Plastic

#### Inner and outer tray

- 7237 Slate Paint

#### End caps for outer tray

- 6694 Slate Plastic

#### Pad

- 6615 Grey V5 Plastic



# Universal Systems Worksurfaces with Power Access Door

**Power access door option on worksurfaces** allows for convenient pass through access to panel outlets.

**Systems straight worksurfaces with power access door** are available in a variety of widths and depths in modular and parametric dimensions.

**Power and data access door** provides desk top access and management of cords.

**Power access door** is only available on worksurfaces with a 1/2" cord drop.

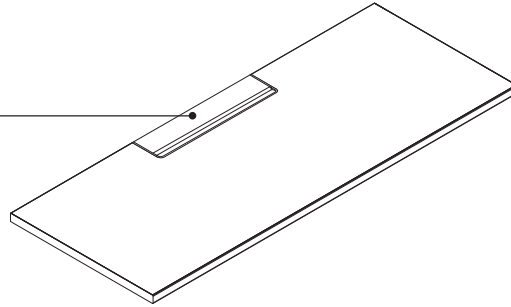

## Actual Dimensions

Modular*	Parametric*	Centered	Left	Right	Left and Right	Left and Center	Right and Center	Left, Right, and Center
<b>Straights — 18<sup>3</sup>/<sub>8</sub>", 23<sup>1</sup>/<sub>2</sub>", and 29<sup>1</sup>/<sub>2</sub>"D*</b>	<b>Straights — 18"D-36"D</b>							
30"W	30"W – 35 <sup>15</sup> / <sub>16</sub> "W	●						
36", 42", and 48"W	36"W – 53 <sup>15</sup> / <sub>16</sub> "W	●	●	●				
54", 60", and 66"W	54"W – 71 <sup>15</sup> / <sub>16</sub> "W	●	●	●	●			
72", 78", 84", 90", and 96"W	72"W – 120"W	●	●	●	●	●	●	●
<b>Straight 120° Worksurfaces — 23<sup>1</sup>/<sub>2</sub>" and 29<sup>1</sup>/<sub>2</sub>"D</b>								
48" and 60"W	N.A.	●	●	●				
72"W	N.A.	●	●	●	●	●	●	●
<b>Square Edge Tops — 18<sup>3</sup>/<sub>8</sub>" and 23<sup>1</sup>/<sub>2</sub>"D</b>								
30", 36", and 42"W	N.A.	●						
48", 54", 60", and 66"W	N.A.	●	●	●				
72", 78", 84", 90", and 96"W	N.A.	●	●	●	●	●	●	●

## Dimensions

### Cutout for Door

Width	16 <sup>1</sup> / <sub>8</sub> "
Depth	4 <sup>1</sup> / <sub>4</sub> "

\*Tip: Modular 29<sup>1</sup>/<sub>2</sub>"D worksurface is only available up to 72"W.

\*Tip: Worksurface width is available parametric from 18"W-120"W in 1/16" increments.

\*Tip: Worksurface depth can be specified parametric from 18<sup>3</sup>/<sub>8</sub>"D-36"D in 1/16" increments.

## Product Details

### High-Pressure Laminate Worksurfaces

**PVC-free, 3 mm edge profiles** are proprietary polyolefin blend for all solid colors and seven woodgrain finishes. Matching 1 mm side and back edges are also PVC-free.

▶ See *Surface Materials Reference Manual* for specific PVC-free availability.

**3 mm front edge** is specifiable. Back and side-edges match 3 mm front edge.

**Edge profile finish for 3 mm front edge** is specified separately from laminate color.

### Wood Veneer Worksurfaces

**Front (user's) edge profile** is wood veneer with a square (3 mm) radius. Back edge and edge that joins to adjacent worksurfaces are flat. Wood edge color matches finish specified for worksurface.

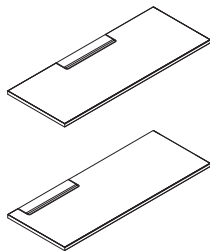

**Scallops** are omitted on all worksurfaces with a power access door.

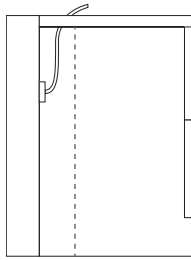

**Power access door** provides access to power outlets in the panel.

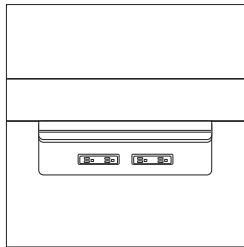

**Universal laminate storage with recessed back should be used** when storage will be placed in front of a power outlet.

**Recessed back storage** features a 3<sup>3</sup>/<sub>4</sub>" cavity to allow access to outlets below the worksurface.

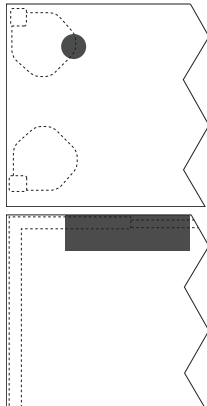

**Left and right configured power access doors** will interfere with FrameOne post leg support and freestanding end panels (UE18, UE24, and UE30).

## Surface Materials

### High-Pressure Laminate Worksurfaces

- Laminate
  - ▶ See *Surface Materials Reference Manual*.
  - Open Line laminate (option)
- A program including non-Steelcase laminates which are suitable for use on Steelcase products.
- ▶ See *Surface Materials Reference Manual*.

### 3 mm front edge

- Plastic

### Back and side edges

- Plastic color default to match 3 mm front edge

### Wood Veneer Worksurfaces

- Wood veneer (standard)
- Customiz stain (option)
- Full-fill finish (option)

### Square (3 mm) edge profile

- Wood veneer to match worksurface

### Front (user's) edge(s)

- Wood edge band

### Power Access Door

#### Door

- 4799 Platinum Metallic
- 7207 Black
- 7241 Arctic White
- 7360 Merle
- 8043 Clear Anodized Aluminum

#### Door bezel

- 6527 Merle

# Universal Panel-Mounted Worksurface Supports

For Kick Panel Applications

**On-module supports** can be used to panel support worksurfaces in various configurations.

► Specifying, page 262

**Worksurface supports** feature alignment tab used to set a depth for Universal Systems Worksurfaces—with  $\frac{1}{2}$ " cord drop. This tab is bent down when installing full-depth worksurfaces.

**Cantilever** can be used to panel-support a worksurface at any height.

**Side support brackets** can be used to support the ends of straight and corner worksurfaces and to support the back corner of any corner worksurface.

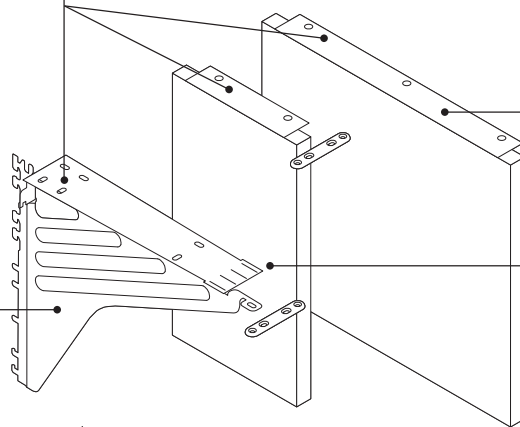

**End panel** can be used to support the end of a worksurface.

**Center support panel** can be shared by two worksurfaces and may be required for longer runs of worksurfaces.

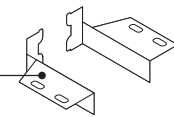

## Product Details

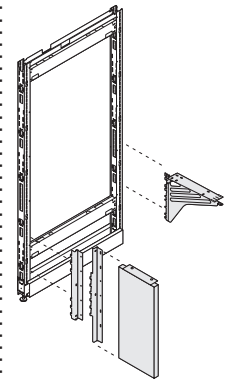

**On-module worksurface supports** engage the slots in the vertical uprights of Kick panels.

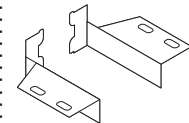

**Side support brackets** support worksurfaces at any height in 1" increments. Brackets ship as a left- and right-hand pair and are ordered separately.

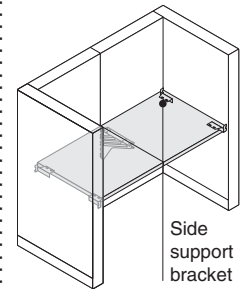

**Side support brackets** can be used to support the end of a worksurface that is wrapped by a panel with the same width dimension that matches the worksurface depth.

## Actual Dimensions

	Cantilever	Center support panel	End panel
Height	12 $\frac{1}{4}$ "	28 $\frac{1}{2}$ " or 40 $\frac{7}{8}$ "*	28 $\frac{1}{2}$ " or 40 $\frac{7}{8}$ "*
Depth	15 $\frac{1}{2}$ "	11"	23 $\frac{3}{4}$ " or 29 $\frac{3}{4}$ "
Glide Range	N.A.	1 $\frac{1}{4}$ "	1 $\frac{1}{4}$ "

\*Height dimensions include the thickness of a worksurface.

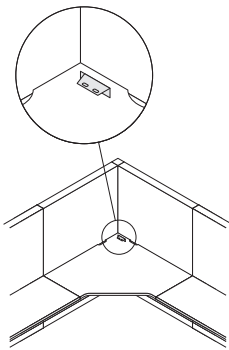

**Single side support bracket** can be used to support the rear corner of corner, extended corner, and 120° corner worksurfaces.  
*Tip: For off-module fin wall applications, the single side support bracket must be handed appropriately for connection to the fin wall.*

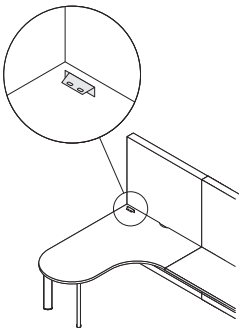

**Single side support bracket** can be used to support the user's side rear corner of bullet peninsula, angled peninsula, visitor, jetty, and bubble jetty worksurfaces.

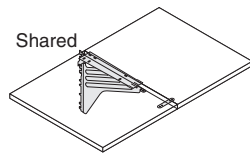
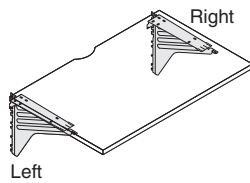

**Cantilevers** support worksurfaces at any height in 1" increments. Cantilever is non-handed and can be used to support either end of a worksurface, or shared to support two worksurfaces at the same height simultaneously. One tie plate ships with each cantilever.

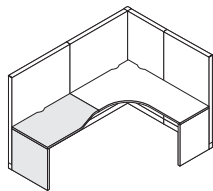

**30°D straight, tapered, and transition cantilevered worksurfaces** require additional floor support along the front edge, such as a pedestal, end panel, post leg, side support bracket, or an adjacent return worksurface.

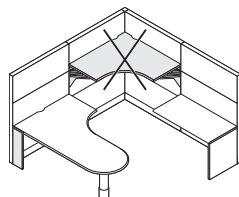

**Adjacent cantilevered worksurfaces** must be the same height in order to connect with a tie plate and provide panel stability.

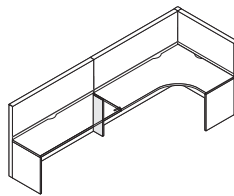

**Center support panel** is an alternative to a cantilever in supporting longer runs of worksurfaces for additional panel stability. Refer to the applicable panel stability guidelines for specific requirements.

**Center support panels** are available in seated and standing heights, and cannot be used in freestanding applications or as a substitute for an end panel. One tie plate ships with each center support panel.

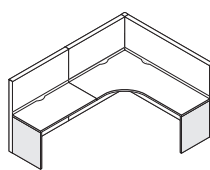

**End panels** can be used to support the end of a worksurface for additional panel stability. Refer to the applicable panel stability guidelines for specific requirements.

**End panels** are available in seated and standing heights, and cannot be used in freestanding applications.

**All panel mounted supports** can be removed and repositioned later without any permanent damage to panels or skins.

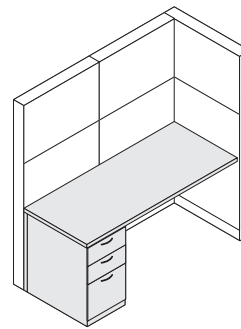

**Pedestals and lateral files** with a filler can be used to support the end of a worksurface in place of an end panel.

▶ See *Storage Specification Guide*.

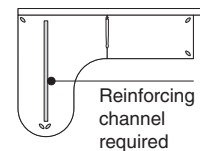
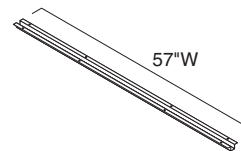

**Worksurface spans greater than 54"** require additional support of a cantilever, pedestal, intermediate support, or leg. Exception; worksurfaces can span up to 60" in heavy load applications and up to 72" in light load applications if a reinforcing channel is used. Reinforcing channel must be specified separately.  
▶ Specifying, page 264

## Surface Materials

### Side support bracket and reinforcing channel

- Black paint only

### Cantilever, center support panel, and end panel

- Paint

# Legs and Columns for Universal Systems Worksurfaces

Without Alignment Tab

**Legs** are available to support worksurfaces in free-standing or panel-supported applications.

► Specifying, page 266

**Post leg** can be used on a single worksurface. Non-locking caster and glide versions are available.

**Column** is 4" in diameter and can be used as a column support on a single worksurface. Adjustable and non-adjustable versions are available.

**Double post leg** can be used as a column support on a single worksurface or to support a shared application.

**Adjustable-height leg** can be used with a single worksurface. Locking caster and glide versions are available.

**Adjustable-height leg** adjusts from 25½"H to 31½"H in ¾" increments.

**Double post C-leg** can be used on a single worksurface or in a shared application.

**Support plate** can be used with a double post leg to join and support two worksurfaces. Plate is 14"D or 20"D and 3⅛"W.

**Leveling glide** allows worksurface height to be adjusted on uneven floors.

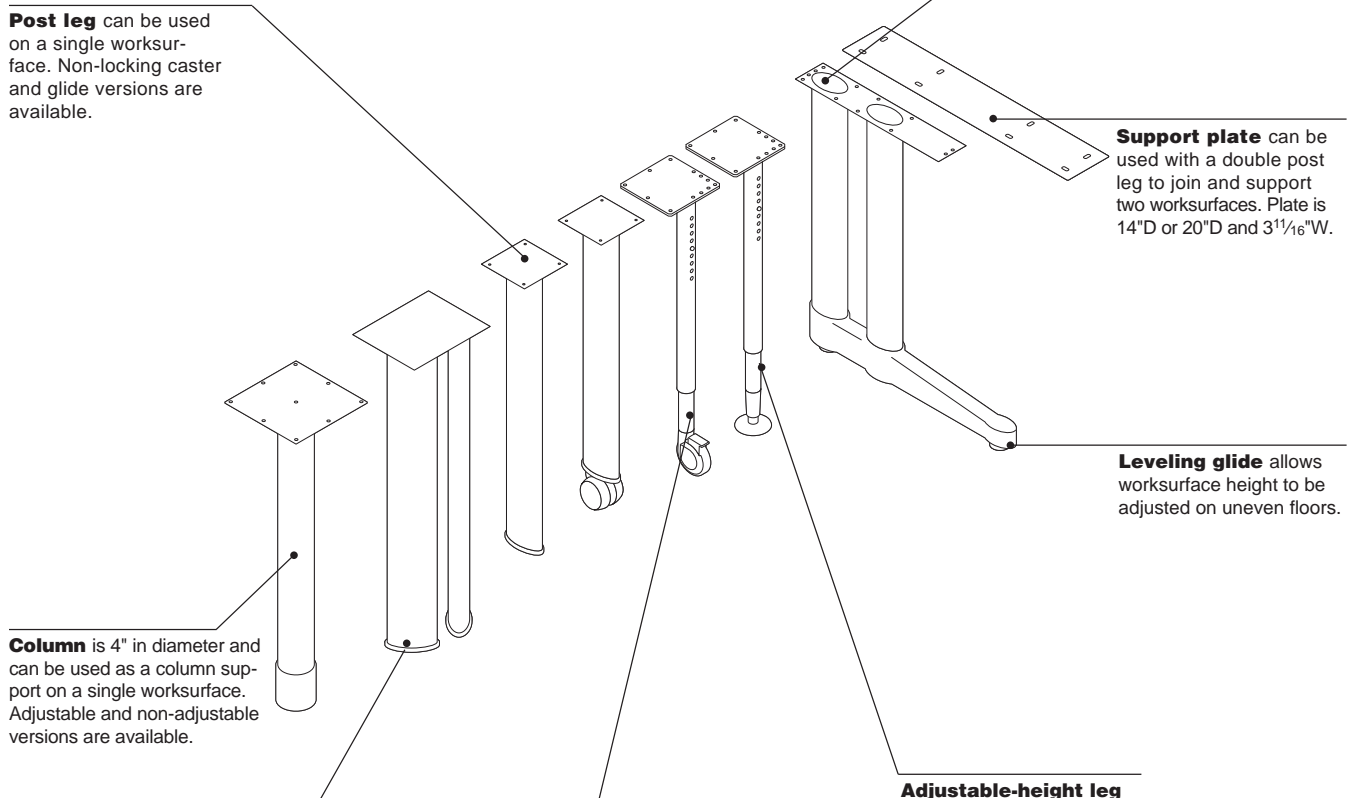

Actual Dimensions							
	Column	Adjustable column	Double post leg	Post leg	Adjustable-height leg	Double post C-leg	Support plate
Height*	28½"	28½"–31⅝"	28½" or 40⅞"	26", 28½", or 40⅞"	25½"– 31½"	28½"	N.A.
Glide range, for legs equipped with glides	1½"	3⅛"	¾"	¾"	¾"	¾"	N.A.

\*Height dimensions include the thickness of a worksurface.

### Product Details

**Legs** support Systems Worksurfaces at 26"H nesting, 28½"H standard, 40⅞"H standing or 25½"H to 31½"H adjustable heights.

**Legs** for Systems Worksurfaces do not include alignment tabs. Pilot holes help the installer locate the proper leg position under the worksurface.



45° orientation

**Post legs** are always installed at a 45° orientation.

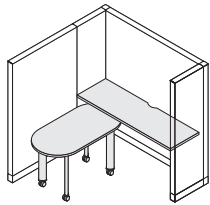

**26"H nesting height legs** allow worksurfaces to nest underneath an adjacent worksurface supported with 28½"H legs or a panel-supported worksurface.

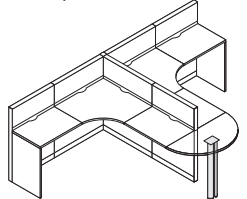
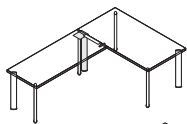

**Double post leg** can be used in a shared application with a support plate, or it can be used as a column support for spanner, jetty, bubble jetty, bullet peninsula, and angled peninsula worksurfaces in panel-mounted applications.

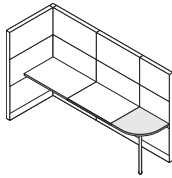

**Post leg**, in conjunction with a side support bracket, can be used to support the end of a visitor or taper-flat worksurface.

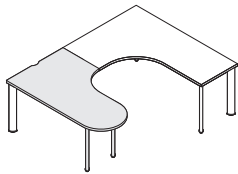

**Two post legs** can be used in place of one double post leg as column support for spanner, jetty, bubble jetty, bullet peninsula, and angled peninsula worksurfaces for added stability.

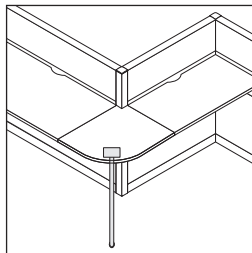

**Standing-height post or double post legs** can be used as column support in panel-mounted applications only.

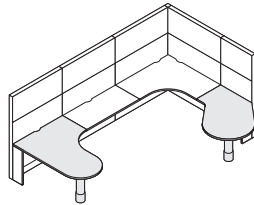

**Column** can be used on spanner, bullet peninsula, angled peninsula, jetty, and bubble jetty worksurfaces in panel supported applications.

**For U-Free desk applications, column** can be used on bullet peninsula and jetty worksurfaces. Adjustable and non-adjustable versions are available.

**Column** cannot be used in a shared application.

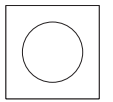

Bottom View Column



Bottom View Post Leg

**Column** is not recommended for applications that include post legs because it has a round shape, while post legs are more of an elliptical shape. Use single or double post legs as a column support in applications that include other post legs.

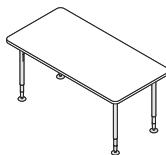
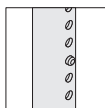

**Adjustable-height legs** adjust from 25½"H to 31½"H in ¾" increments. Legs can be used to support the primary worksurface, or legs can support a worksurface in a nesting application.

**The adjustable-height leg with casters** cannot support freestanding worksurfaces that are less than 24" deep.

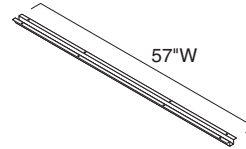

57"W

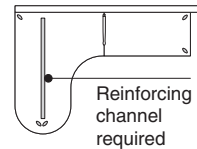

Reinforcing channel required

**Worksurface spans greater than 54"** require additional support of a cantilever, pedestal, intermediate support, or leg. Exception; worksurfaces can span up to 60" in heavy load applications and up to 72" in light load applications if a reinforcing channel is used. Reinforcing channel must be specified separately. ▶ Specifying, page 263

### Surface Materials

**Post legs, C-leg, adjustable-height leg, and adjustable column**

- Paint

**Post leg caster**

- Black plastic only

**Support plate and reinforcing channel**

- Black paint only

### Application Topics

**Freestanding Guidelines for TS Series Worksurfaces with Legs**

- ▶ Page 68

# Knife Edge Worksurface Application Guidelines

**When planning an L-configuration**, two UFB flat brackets should be used to support the worksurfaces. A cantilever is not wide enough to support the gap where the knife edge worksurface comes together.

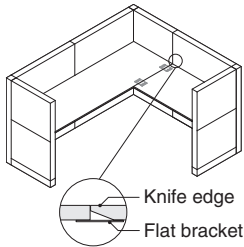

**Freestanding L-configuration** should be avoided due to profile on the backside of the worksurface.

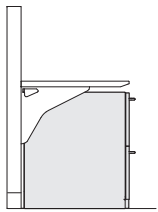

25<sup>1</sup>/<sub>2</sub>"H Pedestal  
(cantilever supported worksurface)

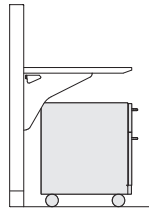

Box/file  
(cantilever supported worksurface)

**Compatible storage** includes 25<sup>1</sup>/<sub>2</sub>"H pedestal with freestanding conversion kit, box/file mobile pedestals, and 1-high storage.

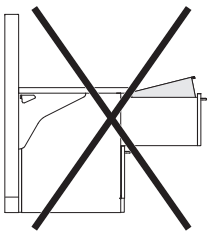

Knife Edge with 27"H Lateral  
and 27"H Pedestal

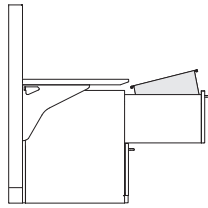

Knife Edge with 25<sup>1</sup>/<sub>2</sub>"H Pedestal

**Knife edge worksurface over 27"H storage** can make files difficult to access. Use a 25<sup>1</sup>/<sub>2</sub>"H pedestal that is flush with the front edge of the worksurface to avoid this issue.

**Knife edge worksurfaces** require reinforcement channels for unsupported spans greater than 48". Use TS7WKSPT39 for 54"W worksurfaces, TS7WKSPT for 60"W and 66"W worksurfaces, and TS7WKSPT72 for 72" worksurfaces.

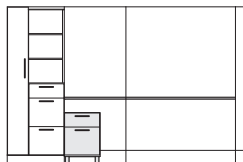
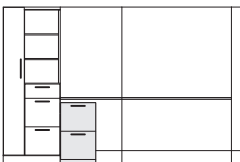

**Although a 25<sup>1</sup>/<sub>2</sub>"H pedestal looks good when paired with knife edge**, keep in mind that it does not align with other storage – drawers and base trim do not align. Use a box/file mobile pedestal instead.

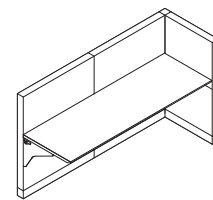
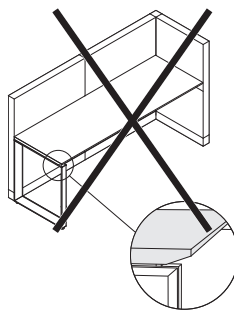
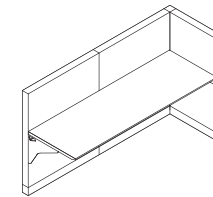
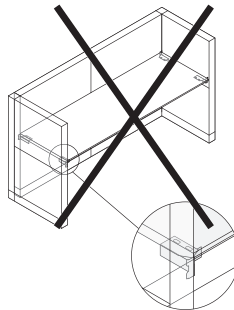
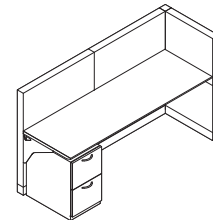
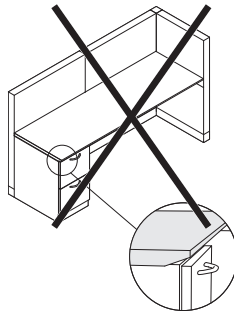
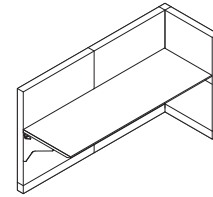
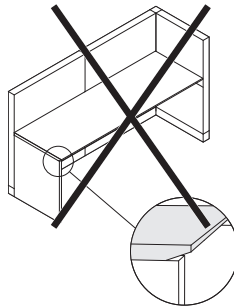

**End panels, 27"H standard pedestals, side support brackets and FrameOne legs for Universal** do not align properly with knife edge worksurfaces. Instead, use cantilevers as shown.

\*\*Side support brackets will work to support the back end of a worksurface; front end is where they won't align properly.

# Freestanding Guidelines For Universal Systems Worksurfaces with Legs

The following section on freestanding worksurfaces gives some guidelines to be used with common freestanding configurations.

Counterweight packages for storage products are required to ensure product stability.  
▶ See page 111 for *Counterweight Requirements for Storage Products*.

Remember to specify "omit scallops" option on worksurfaces intended for use in freestanding applications.

There are several ways to support the ends of a freestanding worksurface:

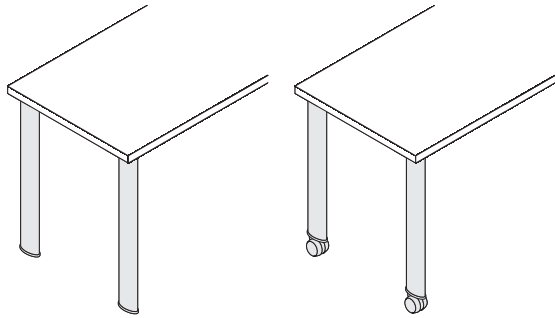

With post legs. Nesting post legs can also be used.

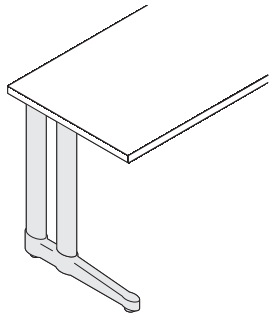

With a double post C-leg.

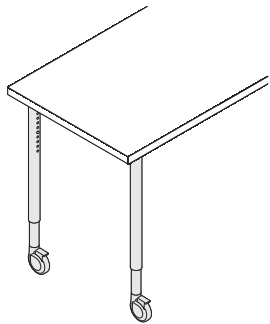

With adjustable-height legs.

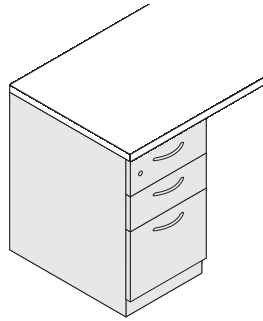

With a pedestal. Other storage products can also be used.

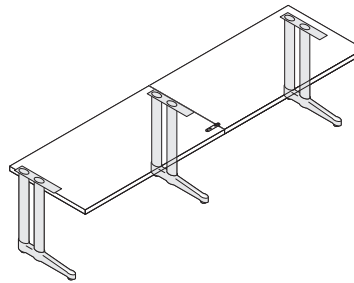

Double post C-legs can be used on a single worksurface or in a shared application.

## Freestanding Guidelines For Universal Systems Worksurfaces with Legs, continued

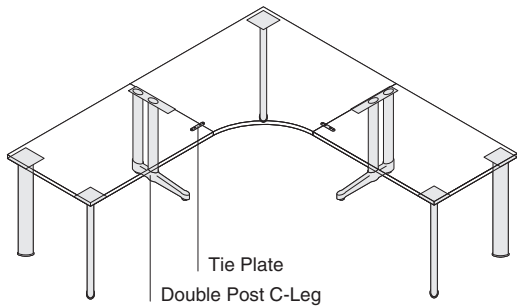

**Tie plate** is recommended to align worksurfaces.

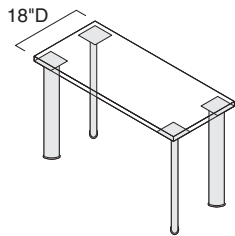

**18"D worksurfaces** can be freestanding down to 24"W.

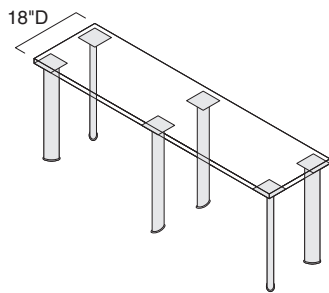

**Freestanding worksurfaces greater than 72"W** need additional center front and back floor support.

**The adjustable-height leg with casters** cannot support freestanding worksurfaces that are less than 24" deep.

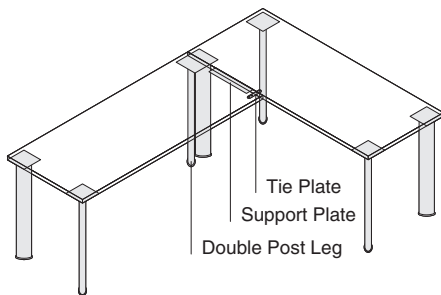

**Combined worksurfaces** can give each other support when joined with a double post leg and support plate. Use 14"D support plate on worksurfaces 24"D and smaller and 20"D support plate on worksurfaces 24<sup>1</sup>/<sub>16</sub>"D and larger. Tie plate is recommended to align the worksurfaces.

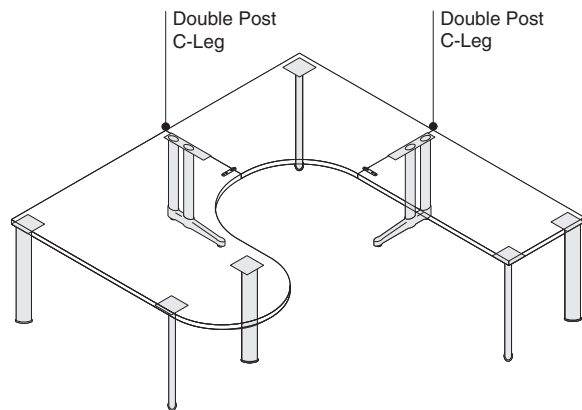
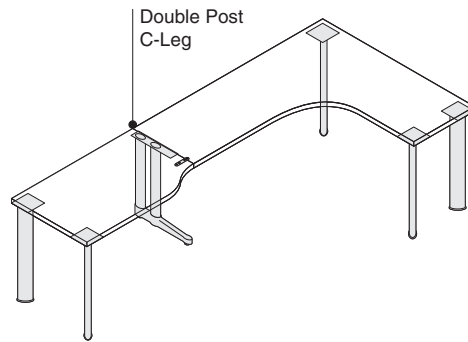

**Double post C-leg** can be used to support a corner or extended corner work surface and adjacent worksurfaces.

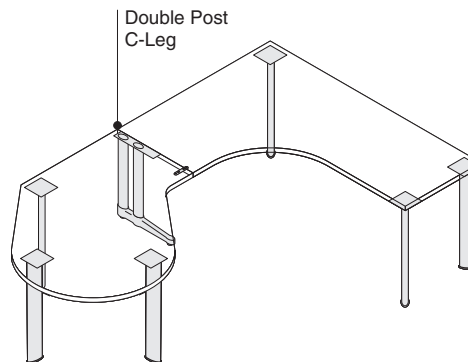

**Double post C-leg** can be used to support an extended corner work surface and adjacent worksurfaces.

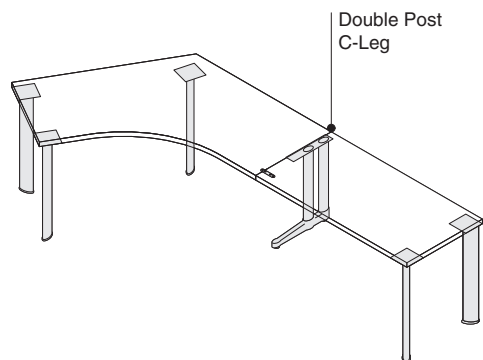

**Double post C-leg** can be used to support a corner, 120° work surface and adjacent worksurfaces.

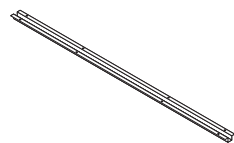

**Worksurface spans greater than 54"** require additional support of a cantilever, pedestal, intermediate support, or leg. Exception; worksurfaces can span up to 60" in heavy load applications and up to 72" in light load applications if a reinforcing channel is used. Reinforcing channel must be specified separately.

► Page 264

# Divisio Side Screen

**Divisio side screen** is magnetic and provides a territorial boundary between users. The user-movable functionality allows users to decide when and where they need additional privacy. The screens may be used on any  $\frac{3}{4}$ "- to  $1\frac{1}{2}$ "-thick work surface.

► Specifying, page 269

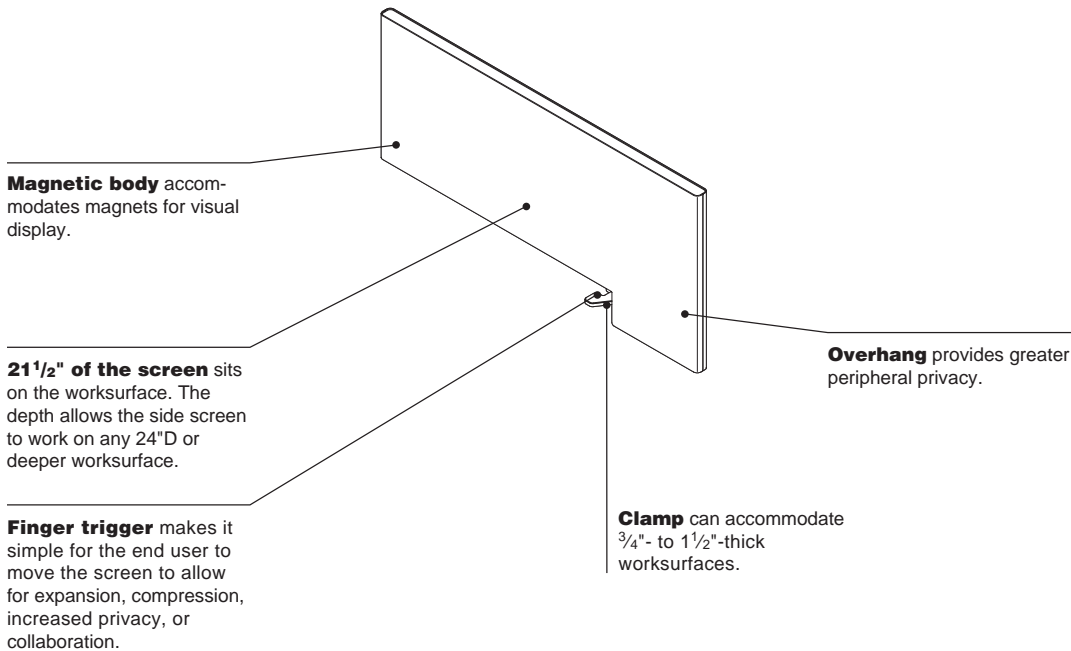

## Product Details

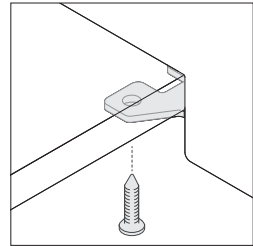

**Divisio side screen** can be made more permanent by adding two screws through the clamp. For work surfaces 1" thick or less; FrameOne, Ology, Migration, a #10 x  $\frac{3}{4}$ " countersunk wood screw is recommended. For work surfaces over 1", a #10 x  $\frac{7}{8}$ " countersunk wood screw is recommended.

## Actual Dimensions

<b>Depth</b>	29 $\frac{1}{2}$ " (total), 21 $\frac{1}{2}$ " (sits on work surface)
<b>Width</b>	1 $\frac{1}{4}$ "
<b>Height</b>	14 $\frac{1}{4}$ " (total), 11 $\frac{5}{8}$ " (above work surface)

---

# Understanding Counterweights

<b>Counterweights</b>	<b>110</b>
<b>Counterweight Requirements for Storage Products</b>	<b>111</b>

# Counterweights

**Counterweight packages** are required to ensure product stability and are ordered as an option or separately. Product specification pages indicate the correct counterweight package for each style number and any exceptions where counterweights are not required.  
 ▶ See *Counterweight Requirements for Storage Products*, page 111.

## Counterweight Packages for Lateral Files and Cabinets

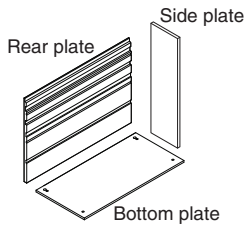

▶ Specifying, page 332

### Product Details

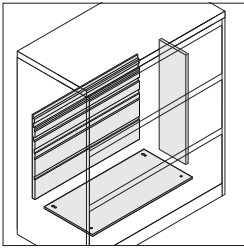

### Surface Materials

**Counterweight plates**  
 • Black only

### Actual Dimensions

**Depth** 3 $\frac{1}{8}$ " or 2 $\frac{3}{8}$ "  
**Width** 25 $\frac{1}{2}$ "  
**Height** 18"

## Counterweight Package for Towers

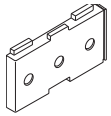

▶ Specifying, page 333

### Product Details

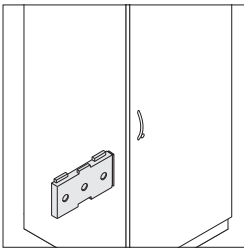

### Surface Materials

**Counterweight**  
 • Black only

### Actual Dimensions

**Depth** 1 $\frac{1}{4}$ "  
**Width** 12"  
**Height** 1 $\frac{1}{4}$ "

## Counterweight Packages for Bookcases

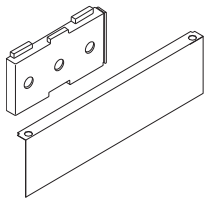

### Product Details

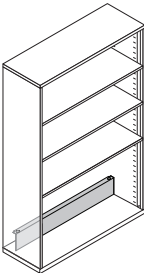

**Counterweight packages** attach to the inside of the bottom shelf. A cover is included to conceal the counterweight.

### Surface Materials

**Counterweight**  
 • Black  
**Cover**  
 • Paint

### Actual Dimensions

**Counterweight**  
**Depth** 1 $\frac{1}{4}$ "  
**Width** 19", 25", 31", or 37"  
**Height** 1 $\frac{1}{4}$ "  
**Cover**  
**Depth** 1 $\frac{3}{8}$ "  
**Width** 23 $\frac{3}{4}$ ", 29 $\frac{3}{4}$ ", 35 $\frac{3}{4}$ ", 41 $\frac{3}{4}$ "  
**Height** 1 $\frac{1}{4}$ "

# Counterweight Requirements for Storage Products

## ⚠️ WARNING

Follow these requirements to reduce the risk of storage products tipping and causing injury.

### Requirements for Lateral Files, Towers, Cabinets, and Bookcases Applications

Specification Information						
Dimensions		W		H	Counterweight Package	Style Number
D	Flush Front	Proud Steel	Steel/Wood			
<b>Three 12"H Drawers</b>						
18"	18 <sup>7</sup> / <sub>8</sub> "	30"	40"	Package 3	<b>RLF18303_</b>	
18"	18 <sup>7</sup> / <sub>8</sub> "	36"	40"	Package 3	<b>RLF18363_</b>	
18"	18 <sup>7</sup> / <sub>8</sub> "	42"	40"	Package 3	<b>RLF18423_</b>	
23 <sup>1</sup> / <sub>8</sub> "	24"	30"	40"	Package 2	<b>RLF24303_</b>	
23 <sup>1</sup> / <sub>8</sub> "	24"	36"	40"	Package 2	<b>RLF24363_</b>	

**Product specification pages** indicate proper counterweight package for each style number.

Specification Information						
Dimensions		W		H	Counterweight Package	Style Number
D	Flush Front	Proud Steel	Steel/Wood			
<b>65<sup>1</sup>/<sub>2</sub>"H Tower with Door Hinged on Left, continued</b>						
<b>Partition with Coat Rod, Two Adjustable Shelves, One Fixed Shelf, and</b>						
23 <sup>1</sup> / <sub>8</sub> "	24"	24"	65 <sup>1</sup> / <sub>2</sub> "	Not required	<b>RFF24245LW_</b>	

**If a counterweight** is not required in any condition for a particular style number, the product specification page will indicate not required.

## Requirements for Freestanding Applications

Counterweights are required as shown in the product specification pages unless any of the following conditions are met:

1. Counterweights are not required for lateral files, towers, cabinets, and bookcases anchored to the floor.

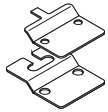

**Floor anchor bracket (for TS Series Storage and Universal Storage with 3" base)** secures lateral files, towers, cabinets, or bookcases to the floor for stability or to reduce the risk of hazards during earthquakes in seismic zones. Four bracket packages are required for each cabinet.

*Note: Local seismic requirements vary. Compliance with local code requirements is the responsibility of the customer or their authorized agent. For a California Office of Statewide Health Planning and Development (OSHPD) approved anchor bracket, contact Steelcase Specials. Tip: Anchor bracket cannot be used with pedestals.*

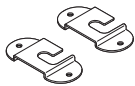

Floor anchor brackets for Universal with FrameOne foot secure lateral files and towers to the floor for stability or in seismic zones to reduce the risk of hazards during earthquakes.

*Note: Local seismic requirements vary. Compliance with local code requirements is the responsibility of the customer or their authorized agent.*

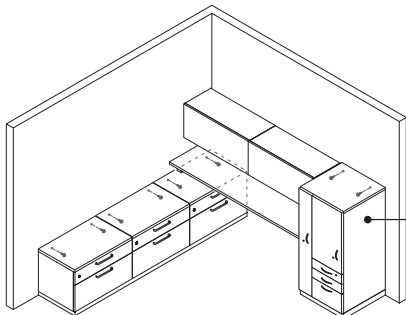

Wall Anchors

2. Counterweights are not required for lateral files, towers, cabinets, and bookcases anchored to the wall.

For wall anchoring of lateral files, towers, cabinets and bookcases, consult with the building's designated design professional (architect or engineer) and work with local codes authorities for approvals to ensure adequate support when product is fully loaded.

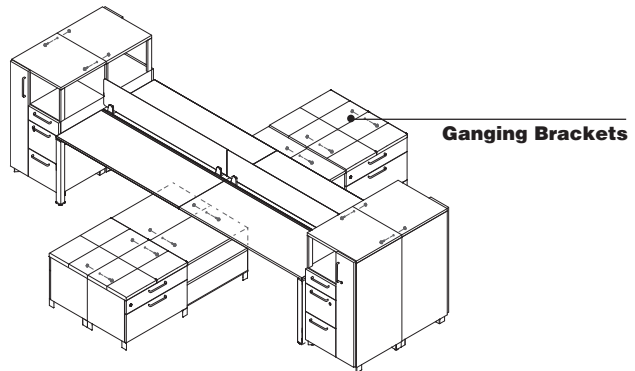

Ganging Brackets

3. Counterweights are not required for lateral files, towers, cabinets, and bookcases ganged back-to-back with ganging hardware.

TS Series towers which do not include ganging hardware, order 8425808SR from Service Parts.

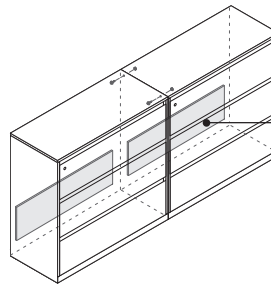

Counterweights

Units ganged side-by-side **require** counterweights.

## Requirements for Panel Applications

Panel stability guidelines must be met prior to determining counterweight requirements.

► See *Panel Stability Guidelines* in the appropriate panel specification guide. (Storage may support panel stability)

Counterweights are required as shown in the product specification pages unless any of the following conditions are met:

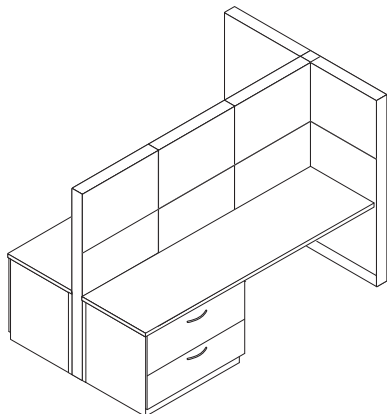

1. Counterweights are not required for Two Drawer lateral files installed right below a worksurface attached to the panel system when the application is mirrored back-to-back (a two-pack minimum).

TS Series underworksurface lateral files are only intended for use under a panel-mounted worksurface and cannot be used as freestanding.

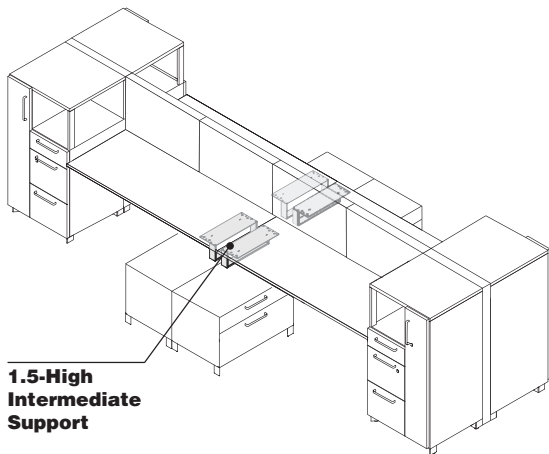

### 1.5-High Intermediate Support

2. Counterweights are not required for One-High and 1.5-High lateral files and cabinets used with an intermediate support, when the application is mirrored back-to-back (a two-pack minimum).

*Note: This includes storage either perpendicular or parallel to the panel.*

### Requirements for Answer Freestanding Desk Applications

Answer Freestanding Desk guidelines must be met prior to determining counterweight requirements.  
▶ See *Answer Freestanding Desk Stability Guidelines* in the *Answer Freestanding Specification Guide*.

Counterweights are required as shown in the product specification pages unless any of the following conditions are met:

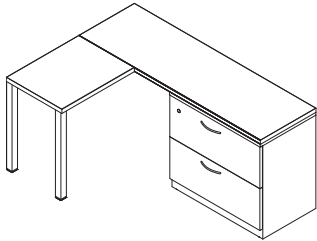

1. A counterweight is not required for a single Two Drawer lateral file attached to desks connected in an L-configuration.

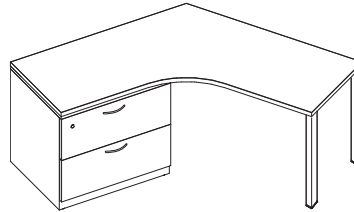

2. A counterweight is not required for a single Two Drawer lateral file attached to a desk made with corner, extended corner, or 120 degree corner worksurfaces.

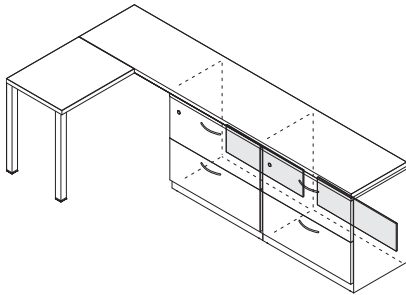

L-configurations with two or more lateral files **require** counterweights in each file.

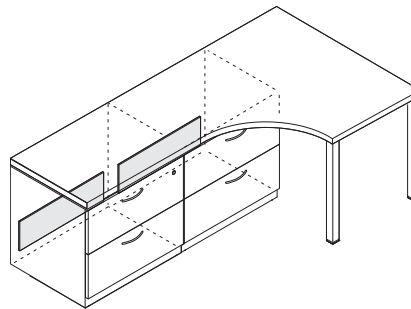

Configurations with two or more lateral files **require** counterweights in each file.

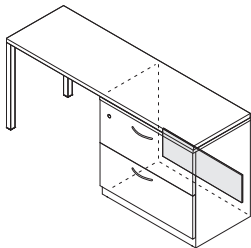

Counterweights are **required** for all lateral files in stand-alone desk or credenza applications.

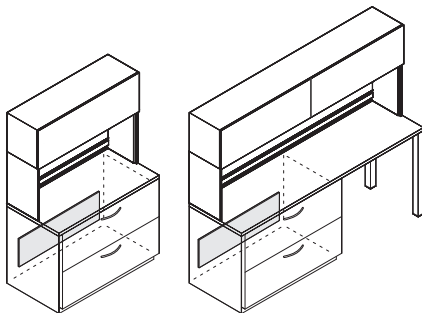

Hutch kit applications with lateral files always **require** counterweights in the lateral files.

### Requirements for Pedestals in Freestanding Applications

Counterweights are required for all freestanding applications.

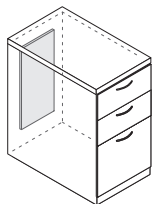

1. Universal fixed pedestals converted to freestanding pedestals require a counterweight and drawer interlock system.

Universal fixed to freestanding pedestal conversion kit includes  $\frac{1}{8}$ "H steel top, counterweight package, and drawer interlock system.

Fixed pedestals, converted to freestanding with a laminate or veneer top, require a counterweight and drawer interlock system. Drawer interlock system is available from service parts.

TS Series fixed pedestals are only intended for use under a panel-mounted worksurface and cannot be converted to freestanding.

Laminate fixed pedestals can never be freestanding.

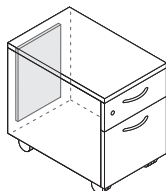

2. Mobile pedestals include counterweight and drawer interlock system as standard.

### Requirements for Pedestals in Panel Applications

Panel stability guidelines must be met prior to determining counterweight requirements.

► See *Panel Stability Guidelines* in the appropriate panel specification guide.

Counterweights are required as shown in the product specification pages unless any of the following conditions are met:

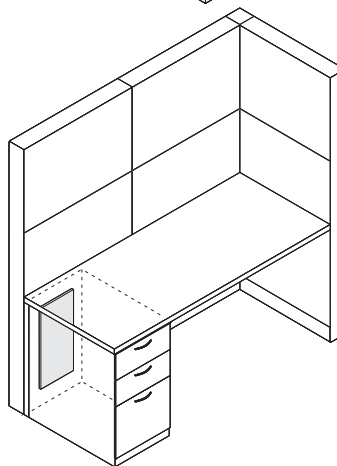
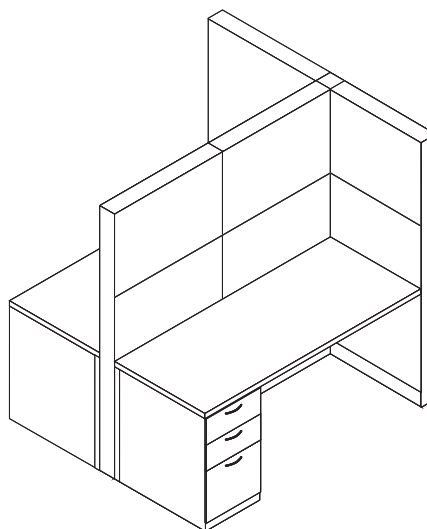

Counterweights are not required for fixed pedestals installed below a worksurface attached in a panel spine application. Single workstation applications **require** a counterweight in each pedestal.

**Requirements for Pedestals in Answer Freestanding Desk Applications**

Answer Freestanding Desk guidelines must be met prior to determining counterweight requirements.  
 ▶ See *Answer Freestanding Desk Stability Guidelines* in the *Answer Freestanding Specification Guide*.

Counterweights are required as shown in the product specification pages unless any of the following conditions are met:

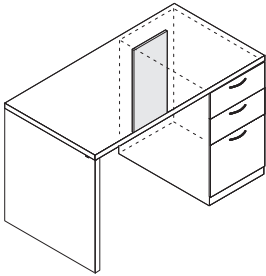

1. Single pedestal desks less than 48"W require a counterweight and an interlock. Single pedestal desks with 30"D pedestals require a counterweight and interlock.

*Tip: Interlock is available as a service part for Universal pedestals, 1043575SR for box/box/file and file/file configurations.*

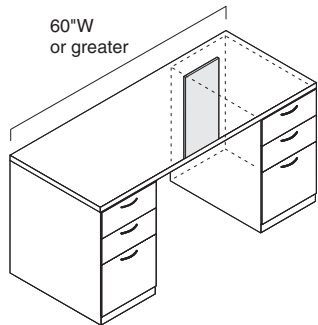

2. Double pedestal desks 60"W and wider only require one pedestal with counterweight.

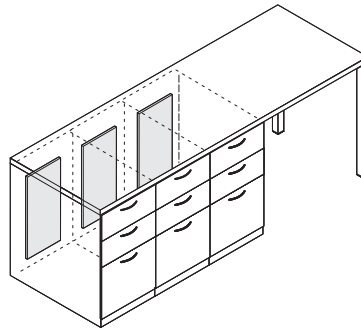
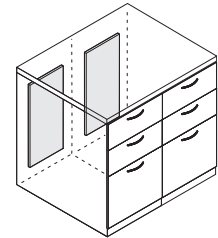
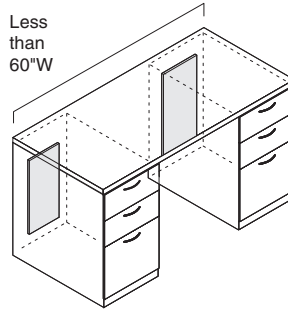

All other desk applications with multiple pedestals **require** a counterweight for each pedestal.

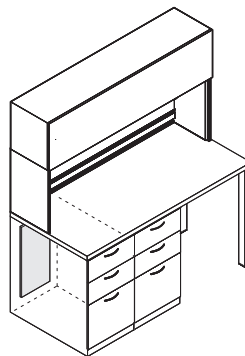
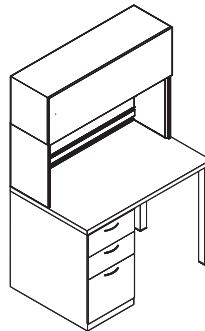

3. Counterweights are not required for a single fixed pedestal in desk with hutch kit applications. Any additional pedestals within the application **require** counterweights.

### Requirements for Pedestals in Answer Freestanding Desk Applications, continued

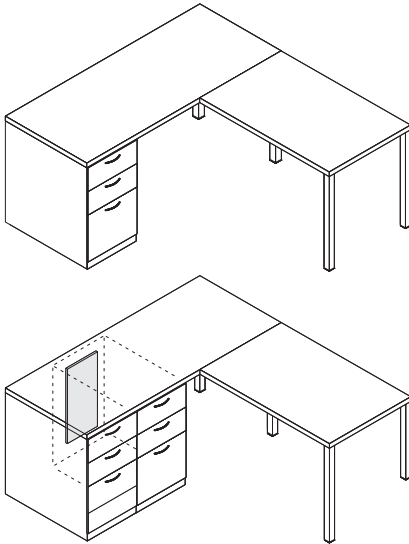

4. A counterweight is not required for a single fixed pedestal attached to a desk attached to another worksurface in an L-configuration. Any additional pedestals within the application require counterweights.

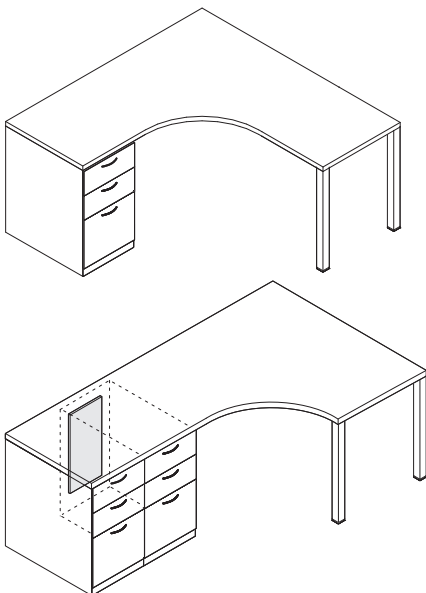

5. A counterweight is not required for a single fixed pedestal attached to desks made with corner, extended corner, or 120 degree corner worksurfaces. Any additional pedestals within the application require counterweights.



---

# Understanding TS Series Storage Products



<b>Statement of Line</b>	<b>120</b>
<hr/>	
<b>TS Series Pedestals</b>	<b>122</b>
<b>TS Series Bins</b>	<b>124</b>
<b>TS Series Laminate Common Shelves</b>	<b>126</b>
<b>TS Series Under-Worksurface Lateral Files</b>	<b>128</b>
<b>TS Series Freestanding Lateral Files</b>	<b>130</b>
<b>TS Series Tower Too</b>	<b>132</b>

# Statement of Line

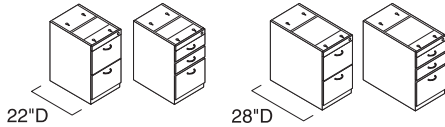

Understanding  
 ▶ Page 122  
 Specifying  
 ▶ Page 272

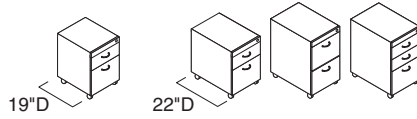

Understanding  
 ▶ Page 122  
 Specifying  
 ▶ Page 274

## TS Series Fixed Pedestals

15"W	
27"H	●

## TS Series Mobile Pedestals with Steel Top

15 1/4"W	
21"H	●
26 5/8"H*	●

\*Available 22"D only.

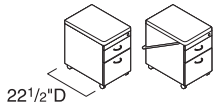

Understanding  
 ▶ Page 122  
 Specifying  
 ▶ Page 275

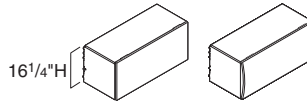

Understanding  
 ▶ Page 124  
 Specifying  
 ▶ Page 277

## TS Series Mobile Pedestals with Seat Cushion

15 1/4"W	16 1/4"W
22 3/4"H	●* ●*

\*With handle

## TS Series Bins

24"W	30"W	36"W	42"W	48"W	60"W	72"W
15 3/4"D	●	●	●	●	●	●

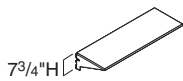

Understanding  
 ▶ Page 126  
 Specifying  
 ▶ Page 279

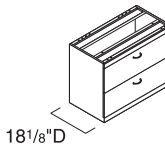

Understanding  
 ▶ Page 128  
 Specifying  
 ▶ Page 280

## TS Series Laminate Common Shelves

24"W	30"W	36"W	42"W	48"W
15"D	●	●	●	●

## TS Series Under-Worksurface Lateral Files

30 1/2"W	36"W
27"H	● ●

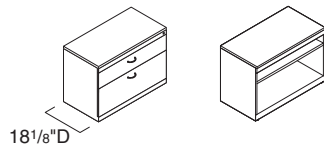

Understanding  
 ▶ Page 130  
 Specifying  
 ▶ Page 281

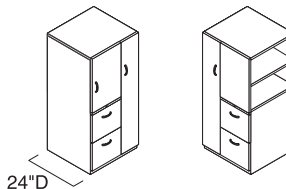

Understanding  
 ▶ Page 132  
 Specifying  
 ▶ Page 284

## TS Series Freestanding Lateral Files

30"W	36"W
21"H	● ●

## TS Series Tower Too

24"W	
48"H	●*
54"H	●
66"H	●

\*Available with open side shelving only.



# TS Series Pedestals

**TS Series pedestals** provide fixed and mobile storage for personal items and filing of infrequently referenced materials.  
 ▶ Specifying, page 272

**Top of pedestal** is open to attach beneath the worksurface.

**Finished back and sides** are standard.

**Leveling glides on pedestals** adjust to install furniture on uneven floors. Leveling glide range is 1".

**Handle, ledge, and contemporary pulls** are available as an option on drawers and doors.

**Pedestal file drawers** are made of steel with steel ball-bearing suspensions and open their full depth for total access to the contents. File drawer accommodates letter- and legal-size filing (legal filing requires the use of optional dividers).

**Handle on mobile pedestal** can be positioned in front or at rear to access contents of drawer. Also available without handle.

**Lock** is standard keyed random and controls all of the drawers. Lock cylinders must be specified separately. Consecutive and specific keying options are available. Master-keyed locks are also available. Products with locks ship with a lock face ring and removable plastic plug to accommodate a lock cylinder installed on site.  
 ▶ *Lock and Keying Options*, page 374

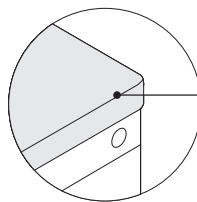
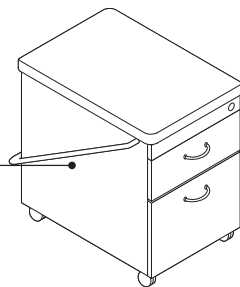
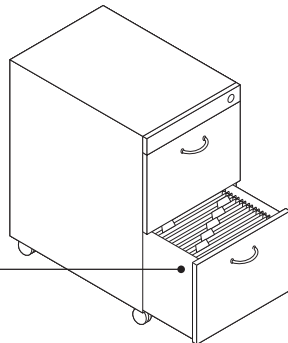
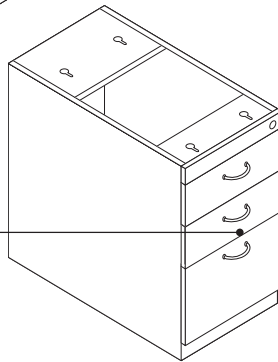
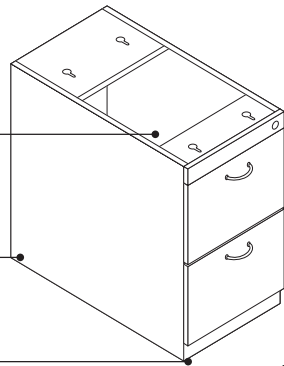

**Cushion tops** are 1¾" thick.

## Actual Dimensions

	Fixed Pedestals	Mobile Pedestals with Steel Top	with Cushion Top
Depth	21 <sup>3</sup> / <sub>16</sub> " , 27 <sup>13</sup> / <sub>16</sub> "	23" and 19"	22"
Width	15 <sup>3</sup> / <sub>16</sub> "	15 <sup>3</sup> / <sub>16</sub> "	15 <sup>3</sup> / <sub>16</sub> "
Height	27"	21" , 26 <sup>5</sup> / <sub>8</sub> "	21"

**Product Details**

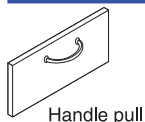

Handle pull

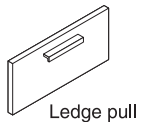

Ledge pull

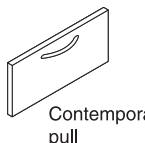

Contemporary pull

**Pull Choices**

Handle, ledge, and contemporary pulls are available as an option on drawers and doors.

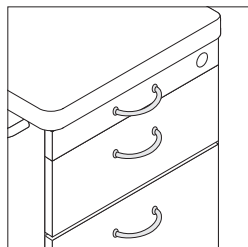

**Extra handle pull**, available as an option on mobile pedestals, allows pedestals to be moved easily within the workstation.

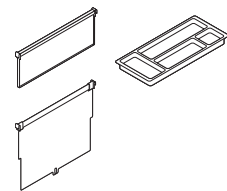

**Box drawer and file drawer dividers and pencil tray** for use with fixed pedestals are available as optional accessories. Mobile pedestals have different dividers that are not interchangeable.

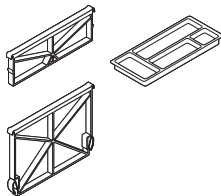

**Dividers and pencil tray** for use with mobile pedestals must be ordered separately. Mobile pedestal accessories are not interchangeable with under-worksurface pedestal accessories.

▶ Page 276

*Tip: Under-worksurface pedestals shipped prior to January 2005 require the use of drawer accessories from the mobile pedestal collection.*

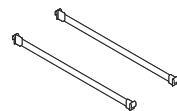

**To file legal-size or side-to-side letter-size filing** in pedestal file drawers, specify optional 15"W file rails.

**Counterweight packages** are required to ensure product stability and are ordered as an option or separately. Product specification pages indicate the correct counterweight package for each style number and any exceptions where counterweights are not required.

*Tip: TS Series pedestal counterweights are available from Service Parts catalog.*

**Connections**

**TS Series fixed pedestals** are only intended for use under a panel-mounted worksurface. Attachment hardware is provided.

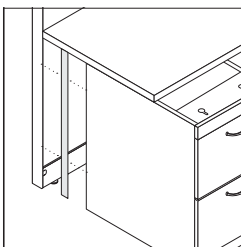

**Pedestal filler**, ordered separately, adds structure and fills the gap between the pedestal and panel. TS Series pedestal filler works with Kick panels only.

▶ Page 290

**Mobile pedestal** fits under 24"D and 30"D work-surfaces or can be moved wherever storage is needed.

**Wiring & Cabling**

**Fixed pedestals** do not accommodate cable-routing. Plan accordingly when installing pedestals underneath worksurfaces with grommets of other cable-routing accessories.

**Surface Materials**

**Pedestal**

- Paint

**Handle pull**

- 0835 Black
- 9211 Nickel

**Contemporary pull**

- 0835 Black
- 9201 Polished Chrome
- 9211 Nickel
- 9212 Silver

**Ledge pull**

- 4799 Platinum
- 7207 Black

**Lock**

- 9201 Polished Chrome

**Cushion top**

- Fabric

**Application Topics**

▶ For interior dimensions, see *Storage Capacities and Dimensions* in the *Storage Specification Guide*.

**Counterweight Requirements for Storage Products**

▶ Page 111

**Shipping**

**Fixed pedestals** are normally shipped in heavy-duty, recyclable stretch wrap to reduce the amount of corrugated board needed.

**Mobile pedestals** are shipped in corrugated board to minimize damage during transport.

# TS Series Bins

**TS Series bins** can be attached to Answer and Kick with integrated hooks. These storage bins provide overhead storage in the workspace.

► Specifying, page 277

**On-module attachment hooks** are integral to the end supports and are used to mount bins on panels of the same width as bins.

**Safety catch** locks overhead storage unit to frame to prevent accidental removal.

**Bin** is steel and ships assembled.

**Backstop** prevents notebooks and equipment from damaging the surface of the panels or walls.

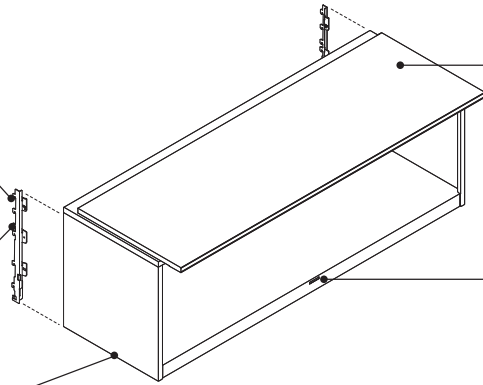
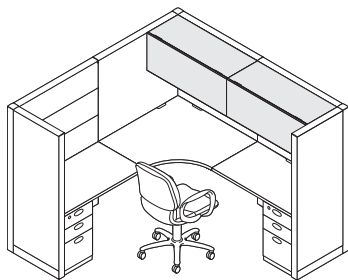

**Flat-front lift-up doors** open and close quietly. When up, the doors rest on top of the case to provide more storage space inside.

**Locks** are standard on bins to secure the door(s). Lock is located underneath the center of the shelf. Locks are standard factory-installed, keyed random. Two-door units are keyed alike.

► *Lock and Keying*, page 374

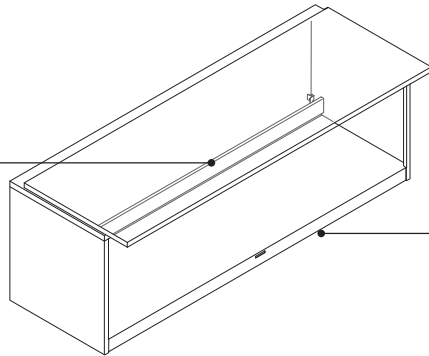

**Recess** beneath unit can accommodate a shelf light.  
► Page 340

## Product Details

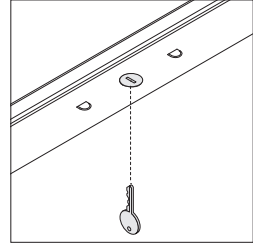

**Lock** in bin is concealed from view beneath the shelf. Locks are available factory- or field-installed. Factory-installed locks are standard and available keyed random only. Two-door units are keyed alike. Optional field-installed locks are available with consecutive, specific, and random keying options. Master-keyed locks are also available. Field-installed lock cylinders must be specified separately.

► *Lock and Keying*, page 374

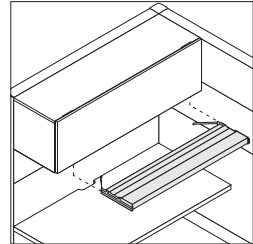

**Shelf lights** are available for use beneath bins. Lights recess into the bottom of overhead bins.

► Page 340

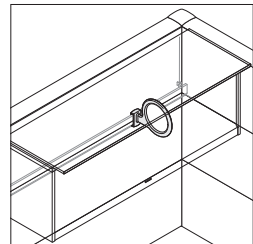

**Dividers** are available as an option for use on bins. Dividers ship in a package of four.

► Page 304

## Actual Dimensions

<b>Depth</b>	15 <sup>3</sup> / <sub>4</sub> "
<b>Width</b>	24", 30", 36", 42", 48", 60", or 72"
<b>Height</b>	16 <sup>1</sup> / <sub>4</sub> "

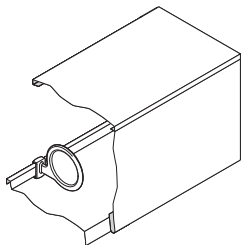

**Back of storage bin** is open to allow panel surface to show. Metal backstop prevents contents of bin from damaging panel surface.

**Overhead storage bin height** accepts standard and A4 binders.

**Connections**

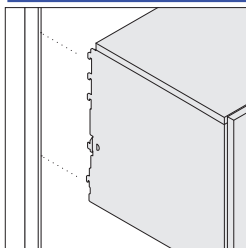

**Steel support hooks** on end supports insert into the slotted channel of a panel or wall channel and lock into place with a safety catch.

**On-module steel support hooks** can be used above and adjacent to slat-wall on Kick panels.

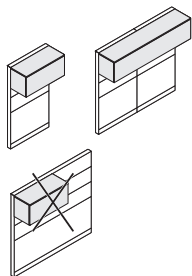

**Width of overhead bin** must match the width of the panel or panels that it is attached to. Bin may span up to two frames.

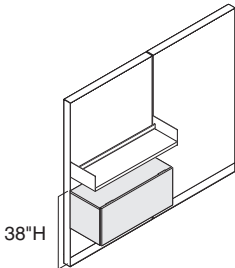

**TS Series bin** may be mounted at 38"H or lower if another panel-mounted component prevents it from being seated upon.

**TS Series bins** cannot be attached to upmount brackets.

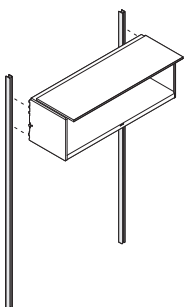

**Wall channels** are available to attach bins to concrete or block walls. Wall channels can be used to attach bins and tackboards to wood, dry wall, or plaster walls if the wall is reinforced.   
▶ Page 156

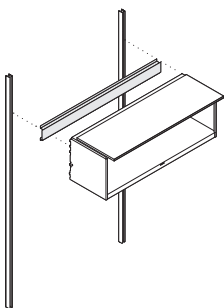

**Wall channel horizontal brace** is required with wall channels to support shelves and bins that are wider than 48".   
▶ Page 156

**Wiring & Cabling**

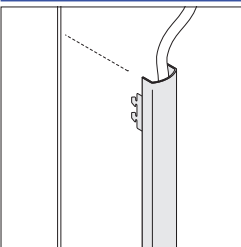

**Vertical wire managers** are available to conceal cords that are routed from light mounted beneath overhead storage.   
▶ Page 350

**Surface Materials**

**Overhead bin**

- Paint

**Lock**

- 9201 Polished Chrome

**Dividers**

- White plastic

**Application Topics**

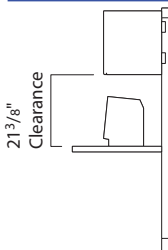

**Clearance** between Universal Systems work-surfaces or Universal tables and bottom of overhead bins is 21<sup>3</sup>/<sub>8</sub>" when storage unit is installed in the highest position on a 66"H panel and glides are adjusted all the way into the panel.

**Storage Capacities and Dimensions**

▶ See *Storage Specification Guide*.

**Bracket Application Rules for Bins and Shelves**

▶ Page 158

**Stability Guidelines**

▶ Page 26

**Guidelines for Stackable Components**

**TS Series bins, Universal bins, and shelves** can hang from first or second stacked tier, as long as it is not above 66"H.

**Only TS Series bins, Universal over the case bins or shelves** can be supported on the second stacked tier.

# TS Series Laminate Common Shelves

► Specifying, page 279

**Laminate common shelf** has a wood core and is covered with Low-Pressure Laminate and High-Pressure Laminate. Plastic edge band is selectable.

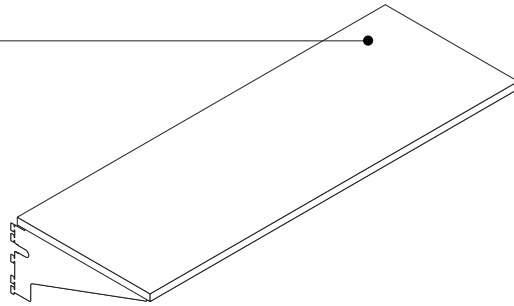

Laminate common shelf

*Tip: For anticipated heavy loads on 42" and 48"W laminate common shelves, a field-installed reinforcing channel (TSATRC39) can be used.*

## Product Details

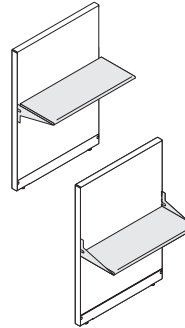

**Laminate common shelf** ships with steel support brackets. Support brackets hook into the vertical panel slots or wall channel and lock into place with a safety catch. Support brackets can be used in either orientation.

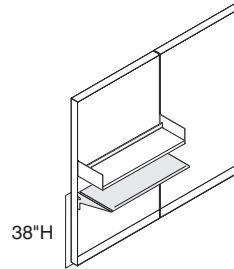

**TS Series shelf** may be mounted at 38"H or lower if another panel-mounted component prevents it from being seated upon.

## Wiring and Cabling

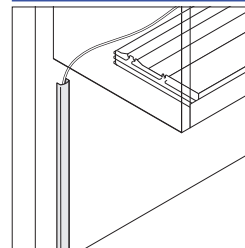

**Vertical wire managers** are available to conceal cords that are routed from light mounted beneath overhead storage.

► Page 358

## Surface Materials

### Shelf

- Laminate

### Edge

- Plastic

### Supports

- Paint

## Actual Dimensions

<b>Depth</b>	15"
<b>Width</b>	24", 30", 36", 42", or 48"
<b>Height</b>	7 <sup>3</sup> / <sub>4</sub> "



# TS Series Under-Worksurface Lateral Files

► Specifying, page 280

**Top of lateral file** is open to attach beneath the worksurface.

**Finished back and sides** are standard.

**Leveling glides on lateral files** adjust to install furniture on uneven floors. Leveling glide range is 1".

*Tip: The actual depth of under-worksurface lateral files is 18<sup>1</sup>/<sub>4</sub>"D, which will not accommodate the use of the 18"D Kick straight worksurfaces.*

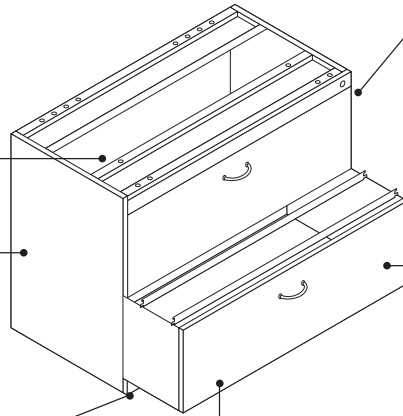

**Lock cylinders** are specified separately from the lateral file. Random, consecutive, and specific keying are available. Master-keyed locks are also available. Products with locks ship with a lock face ring and removable plastic plug to accommodate a lock cylinder installed on site. ► Lock and Keying Options, page 374

**Lateral file drawers** are made of steel with steel ball-bearing suspensions and open their full depth for total access to the contents.

**Lateral file drawers** are standard with two side-to-side hanging file frames to file letter- or legal- size papers. Clearance is provided for two rows of filing.

## Product Details

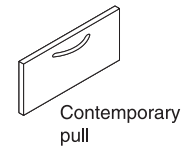
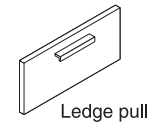
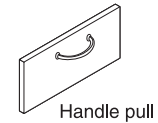

### Pull Choices

Handle, ledge, and contemporary pulls are available as an option on drawers and doors.

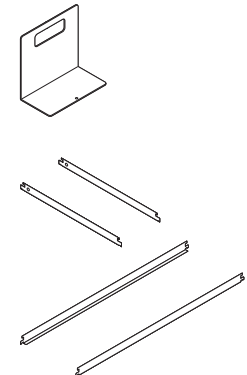

**Under-worksurface lateral file drawer dividers, front-to-back file rails, and side-to-side hanging file frames**, ordered separately, are available for use with under-worksurface lateral files.

**Counterweight packages** are required to ensure product stability and are ordered as an option or separately. Product specification pages indicate the correct counterweight package for each style number and any exceptions where counterweights are not required.

## Actual Dimensions

<b>Depth</b>	18 <sup>1</sup> / <sub>4</sub> "
<b>Width</b>	31 <sup>1</sup> / <sub>2</sub> " or 36"
<b>Height</b>	27"

## Connections

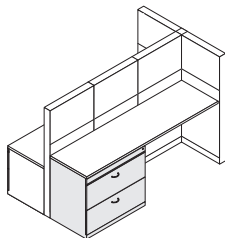

**TS Series underworksurface lateral files** are only intended for use under a panel-mounted worksurface and cannot be used as freestanding.

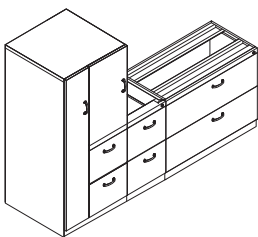

**Kick plate (2"H) and lock bar** align with underworksurface pedestal and Tower Too.

**Ganging hardware** is included to provide alignment by joining adjacent components side-by-side, back-to-back, or both.

► See *Counterweight Requirements for Storage Products*, page 111.

## Floor anchor bracket (for TS Series Storage and Universal Storage with 3" base)

secures lateral files, towers, cabinets, or bookcases to the floor for stability or to reduce the risk of hazards during earthquakes in seismic zones. Four bracket packages are required for each cabinet.

**Note: Local seismic requirements vary.**

*Compliance with local code requirements is the responsibility of the customer or their authorized agent.*

*For a California Office of Statewide Health Planning and Development (OSHPD) approved anchor bracket, contact Steelcase Specials.*

*Tip: Anchor bracket cannot be used with pedestals.*

► Page 333

## Surface Materials

### Lateral file

- Paint

### Handle pull

- 0835 Black
- 9211 Nickel

### Ledge pull

- 4799 Platinum
- 7207 Black

### Contemporary pull

- 0835 Black
- 9201 Polished Chrome
- 9211 Nickel
- 9212 Silver

### Lock

- 9201 Polished Chrome

## Application Topics

► For interior dimensions, see *Storage Capacities and Dimensions* in the *Storage Specification Guide*.

# TS Series Freestanding Lateral Files

► Specifying, page 281

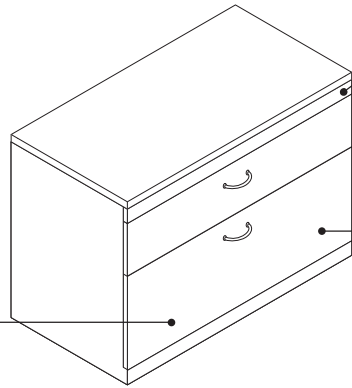

**Lateral file drawers** are standard with two side-to-side hanging file frames to file letter- or legal- size papers. Clearance is provided for two rows of filing.

**Lock cylinders** are specified separately from the lateral file. Random, consecutive, and specific keying are available. Master-keyed locks are also available. Products with locks ship with a lock face ring and removable plastic plug to accommodate a lock cylinder installed on site. ► *Lock and Keying Options*, page 374

**Lateral file drawers** are made of steel with steel ball-bearing suspensions and open their full depth for total access to the contents.

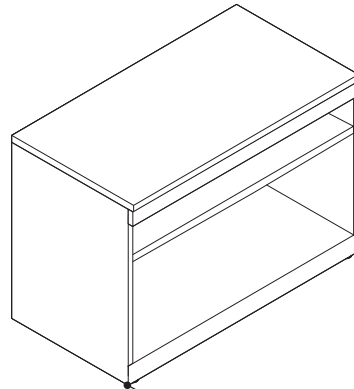

**Leveling glides on lateral files** adjust to install furniture on uneven floors. Leveling glide range is 1".

## Product Details

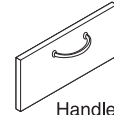

Handle pull

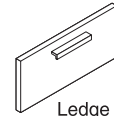

Ledge pull

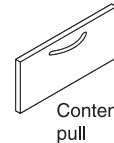

Contemporary pull

### Pull Choices

Handle, ledge, and contemporary pulls are available as an option on drawers and doors.

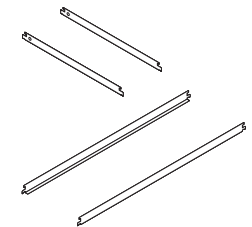
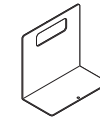

**Under-worksurface lateral file drawer dividers, front-to-back file rails, and side-to-side hanging file frames**, ordered separately, are available for use with under-worksurface lateral files.

## Actual Dimensions

<b>Depth</b>	18 $\frac{1}{8}$ "
<b>Width</b>	30" and 36"
<b>Height</b>	21"

**Counterweight packages** are required to ensure product stability and are ordered as an option or separately. Product specification pages indicate the correct counterweight package for each style number and any exceptions where counterweights are not required.

### Connections

**Ganging hardware** is included to provide alignment by joining adjacent components side-by-side, back-to-back, or both.

▶ See *Counterweight Requirements for Storage Products*, page 111.

**Floor anchor bracket (for TS Series Storage and Universal Storage with 3" base)** secures lateral files, towers, cabinets, or bookcases to the floor

for stability or to reduce the risk of hazards during earthquakes in seismic zones. Four bracket packages are required for each cabinet.

**Note: Local seismic requirements vary.**

*Compliance with local code requirements is the responsibility of the customer or their authorized agent.*

*For a California Office of Statewide Health Planning and Development (OSHPD) approved anchor bracket, contact Steelcase Specials.*

*Tip: Anchor bracket cannot be used with pedestals.*

▶ Page 333

### Surface Materials

#### Lateral file

- Paint

#### Handle pull

- 0835 Black
- 9211 Nickel

#### Contemporary pull

- 0835 Black
- 9201 Polished Chrome
- 9211 Nickel
- 9212 Silver

#### Ledge pull

- 4799 Platinum
- 7207 Black

#### Lock

- 9201 Polished Chrome

### Application Topics

▶ For interior dimensions, see *Storage Capacities and Dimensions* in the *Storage Specification Guide*.

# TS Series Tower Too

**TS Series Tower Too** accommodates paper filing, miscellaneous storage, and wardrobe storage.  
 ▶ Specifying, page 284

**Finished top, sides, and back** allow storage cabinet to be positioned anywhere.

**Shelves** are fixed and can accommodate binders or other storage needs.

**Lock**, standard, is located on the lock bar and secures file drawers below. Lock cylinders are specified separately from the tower. Random, consecutive, and specific keying are available. Consecutive and specific keying options are available. Master-keyed locks are also available. Products with locks ship with a lock face ring and removable plastic plug to accommodate a lock cylinder installed on site.  
 ▶ *Lock and Keying Options*, page 374

**Safety interlock system** allows only one drawer to be opened at a time.

**Leveling glides on lateral files** adjust to install furniture on uneven floors. Leveling glide range is  $\frac{3}{4}$ ".

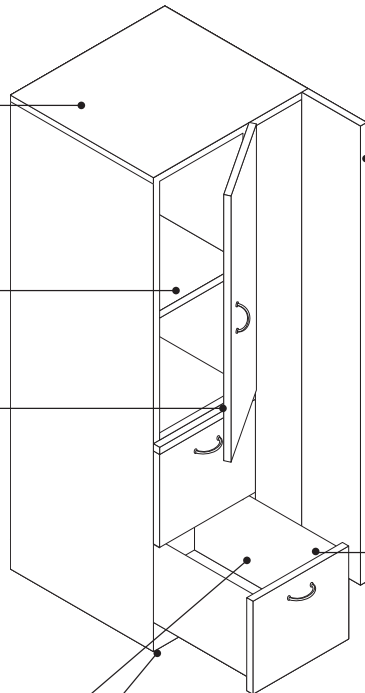

**Doors** open 98° for access to contents.

**Drawers** open their full depth for total access to the contents. Drawers have full-height sides; hanging file folder frames are not needed for front-to-back letter-size filing. Legal or side-to-side filing is accommodated using Universal filing rails. Tower Too file drawers and optional box drawers are made of steel with steel ball-bearing suspensions.

▶ For interior dimensions see *Storage Capacities and Dimensions* in the *Storage Specification Guide*.

## Product Details

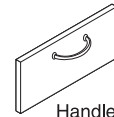

Handle pull

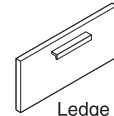

Ledge pull

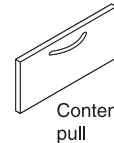

Contemporary pull

### Pull Choices

Handle pull is standard. Ledge pulls are available as an option on drawers and doors. Contemporary pulls are available as unique Tower Too style numbers.



Wardrobe left

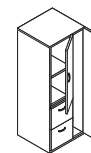

Wardrobe right

**TS Series Tower Too** is available 48"H, 54"H, or 66"H. Wardrobe storage can be left or right. 48"H is open side only.

## Actual Dimensions

<b>Depth</b>	24"
<b>Width</b>	24"
<b>Height</b>	48", 54", or 66"

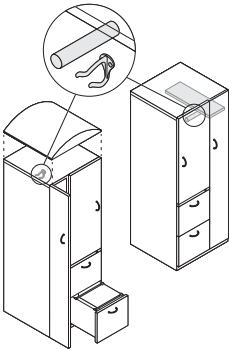

**Wardrobe interior** can be specified with wardrobe hook or wardrobe rod with shelf.

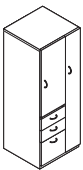

**Two box drawers in place of top file drawer** is available as an option on 48"H, 54"H, and 66"H towers. Box drawers have 3/4 extension.

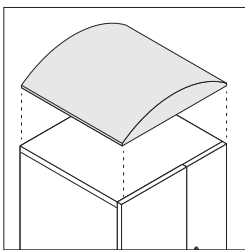

**Dome**, field-installed only, can be added to Tower Too for a unique aesthetic.

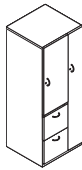

**All locking** (one lock for wardrobe, second lock for drawer, third lock for cabinet if applicable), is available as an option on 48"H, 54"H, and 66"H towers.

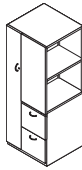

**Towers** are available with open side shelving in place of the upper cabinet. Fixed shelves provide two openings (with clearance of 5"H on 48"H units, 12"H on 54"H units, and 18"H on 66"H units).

**Counterweight packages** are required to ensure product stability and are ordered as an option or separately. Product specification pages indicate the correct counterweight package for each style number and any exceptions where counterweights are not required.

**Connections**

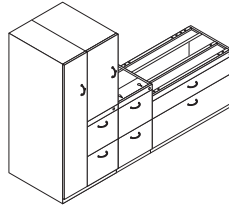

**Kick plate (2"H) and lock bar** align with fixed pedestals and under-worksurface lateral files.

**Ganging hardware** is available to provide alignment by joining adjacent components side-by-side, back-to-back, or both. Order 8425808SR from Service Parts.

**Floor anchor bracket (for TS Series Storage and Universal Storage with 3" base)**

secures lateral files, towers, cabinets, or bookcases to the floor for stability or to reduce the risk of hazards during earthquakes in seismic zones. Four bracket packages are required for each cabinet. *Note: Local seismic requirements vary. Compliance with local code requirements is the responsibility of the customer or their authorized agent. For a California Office of Statewide Health Planning and Development (OSHPD) approved anchor bracket, contact Steelcase Specials. Tip: Anchor bracket cannot be used with pedestals.* ▶ Page 333

**Surface Materials**

**Tower Too**  
• Paint

**Handle pull**  
• 0835 Black  
• 9211 Nickel

**Ledge pull**  
• 4799 Platinum  
• 7207 Black

**Lock**  
• 9201 Polished Chrome

**Application Topics**

▶ For interior dimensions, see *Storage Capacities and Dimensions* in the *Storage Specification Guide*.



---

# Understanding Universal Steel Storage Products

---

<b>Statement of Line</b>	<b>136</b>
--------------------------	------------

<b>Universal Pedestals</b>	<b>140</b>
<b>Universal Sliding Door Bins</b>	<b>144</b>
<b>Universal Over the Case and In the Case Bins</b>	<b>148</b>
<b>Dimensions for Custom Field-Installed Picture Frame Door Inserts</b>	<b>151</b>
<b>Universal Shelves and Universal Personal Shelves Dividers</b>	<b>152</b>
<b>Horizontal Wall Attachment Brackets</b>	<b>154</b>
<b>Wall Hang Channels and Horizontal Braces</b>	<b>155</b>
<b>Slim Shelves</b>	<b>156</b>
<b>Bracket Application Rules for Bins and Shelves</b>	<b>157</b>
<b>Application Rules for Overhead Storage on Answer and Kick Panels</b>	<b>158</b>
<b>Universal One-High, 1.5-High, and Two Drawer Lateral Files</b>	<b>160</b>
<b>Universal Towers</b>	<b>162</b>
<b>Universal Lateral Files</b>	<b>166</b>
	<b>170</b>

# Statement of Line

For the full Universal Storage offering, see *Storage Specification Guide*.

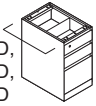

17<sup>1</sup>/<sub>2</sub>"D,  
22<sup>5</sup>/<sub>8</sub>"D,  
or 28<sup>5</sup>/<sub>8</sub>"D

Flush steel front

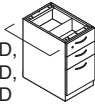

18<sup>3</sup>/<sub>8</sub>"D,  
23<sup>1</sup>/<sub>2</sub>"D,  
or 29<sup>1</sup>/<sub>2</sub>"D

Proud steel, laminate,  
or wood front

Understanding  
▶ Page 140  
Specifying  
▶ Page 288

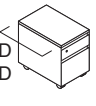

17<sup>1</sup>/<sub>2</sub>"D  
or 22<sup>5</sup>/<sub>8</sub>"D

Flush steel front



18<sup>3</sup>/<sub>8</sub>"D  
or 23<sup>1</sup>/<sub>2</sub>"D

Proud steel, laminate,  
or wood front

Understanding  
▶ Page 140  
Specifying  
▶ Page 292

## Universal Fixed Pedestals

15"W	
25 <sup>1</sup> / <sub>2</sub> "H	●
27"H	●

## Universal Mobile Pedestals

15"W	
21"H	●
27"H	●

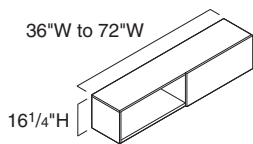

Understanding  
▶ Page 144  
Specifying  
▶ Page 296

## Universal Sliding Door Bins

For Use with Kick

	36"W	42"W	48"W	60"W	66"W	72"W
15 <sup>3</sup> / <sub>4</sub> "D	●	●	●	●	●	●

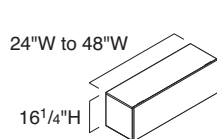

Flat steel, laminate,  
or wood front

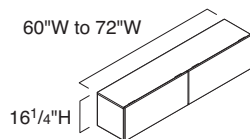

Flat steel, laminate,  
or wood front

Understanding  
▶ Page 148  
Specifying  
▶ Pages 298–300

## Universal Over the Case and In the Case Bins

For Use with Kick

	24"W	30"W	36"W	42"W	48"W	60"W	66"W	72"W
15 <sup>3</sup> / <sub>4</sub> "D	●	●	●	●	●	●	●	●

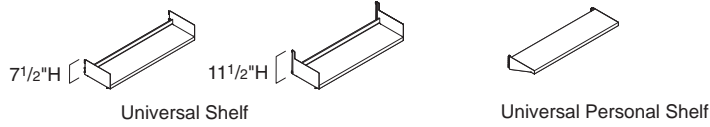

Understanding  
 ▶ Page 152  
 Specifying  
 ▶ Page 303

### Universal Shelves and Universal Personal Shelves

For Use with Kick

	24"W	30"W	36"W	42"W	48"W	60"W	72"W
Universal Personal Shelves 13 <sup>1</sup> / <sub>16</sub> "D	●	●	●	●	●		
Universal Shelves 14 <sup>3</sup> / <sub>4</sub> "D	●	●	●	●	●	●	●

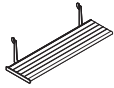

Understanding  
 ▶ Page 157  
 Specifying  
 ▶ Page 308

### Slim Shelves

	24"W	30"W	36"W	42"W	48"W	60"W	72"W	96"W
6"D	●	●	●	●	●	●	●	●

### Universal One-High

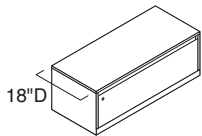

Flush steel front

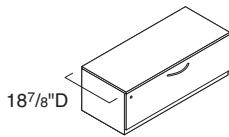

Proud steel, laminate, or wood front

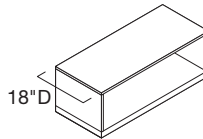

Flush steel open front

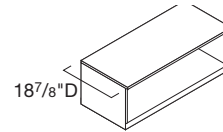

Proud steel open front

### Universal 1.5-High

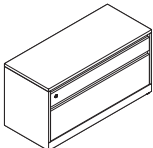

Flush steel front

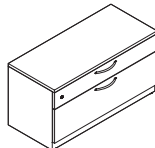

Proud steel, laminate, or wood front

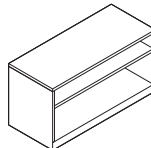

Flush steel open front

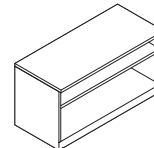

Proud steel open front

Understanding  
 ▶ Page 162  
 Specifying  
 ▶ Page 310

### Universal One-High and 1.5-High Lateral Files

	30"W	36"W	42"W
One-High 16"H	●	●	●
1.5-High 22"H	●	●	●

Tip: 42"W lateral files are available 18"D and 18<sup>7</sup>/<sub>8</sub>"D only.

For the full Universal Storage offering, see *Storage Specification Guide*.

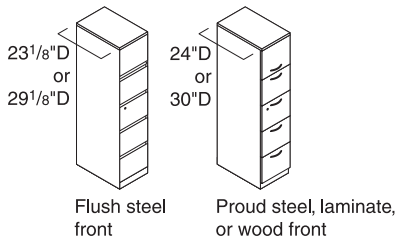

Understanding  
 ▶ Page 166  
 Specifying  
 ▶ Page 318

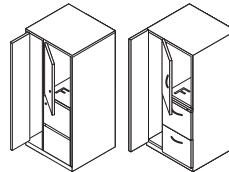

Understanding  
 ▶ Page 166  
 Specifying  
 ▶ Page 322

### Universal Open Side Towers

	24"W
47½"H	●
52"H	●
65½"H	●

Drawings show door hinged left.  
 Units are also available with door hinged right.

### Universal Dual Door Towers

	24"W
47½"H	●
52"H	●
65½"H	●

Drawings show door hinged left.  
 Units are also available with door hinged right.

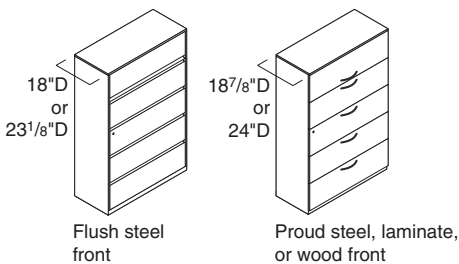

Understanding  
 ▶ Page 170  
 Specifying  
 ▶ Page 328

### Universal Lateral Files

	30"W	36"W	42"W
28"H	●	●	●
40"H	●	●	●
52"H	●	●	●
65½"H	●	●	●

Tip: 42"W lateral files are available 18"D and 18 7/8"D only.



# Universal Pedestals

## 27"H fixed pedestals

are floor-standing and can support worksurfaces at 28½"H.

- ▶ Specifying, page 288
- ▶ Specifying *Storage Accessories*, page 332

**Top** is open and accommodates attachment to a worksurface. Attachment hardware is included.

**Lock** is standard on pedestals and secures all drawers. Lock is located in the top drawer. Locks are standard factory-installed, keyed random.

- ▶ *Lock and Keying*, page 375

**Leveling glides** adjust to install pedestals on uneven floors. 25½"H pedestals have a 7⁄8" adjustable glide range, and 27"H pedestals have a 1 7⁄8" adjustable glide range.

**Mobile pedestals** fit under a worksurface and can be moved wherever storage is needed. They provide an auxiliary work-surface when you need more space to spread out your work.

- ▶ Specifying, page 292
- ▶ Specifying *Storage Accessories*, page 332

**Finished back and sides** are standard.

**Four casters** are hard composition and non-locking, with a full-rotation swivel mechanism. Casters are exposed at the base of box/file pedestals and concealed with the base of box/box/file and file/file pedestals.

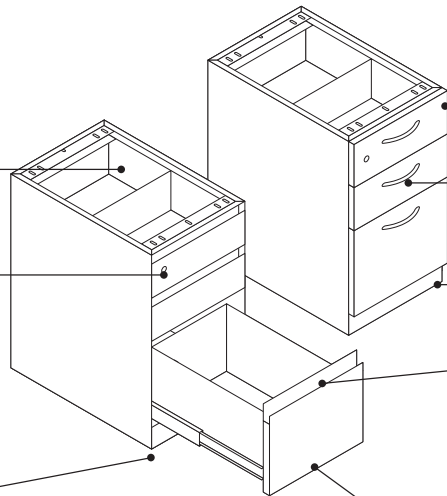

**Drawer fronts** are available in steel, laminate, or wood veneer. Mobile pedestals maintain drawer pull and drawer front alignment with other storage components that have a 3" base.

**Pull on proud-front pedestal** is available in a variety of shapes.

**3"H base** is integral to 27"H pedestal case.

**Pull on flush-front pedestal** is full width and integral. This pull is available on steel drawer fronts only. Full-width wood pull is available as an option. Wood pull, if selected, ships separately from pedestal and is field installed, attaching to the integral pull with double-sided tape.

**Drawers** open their full depth for total access to the contents. Box and file drawers are available.

**Top on mobile pedestal** is 1⁄8"H steel. Additional top options are available.

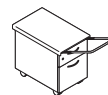
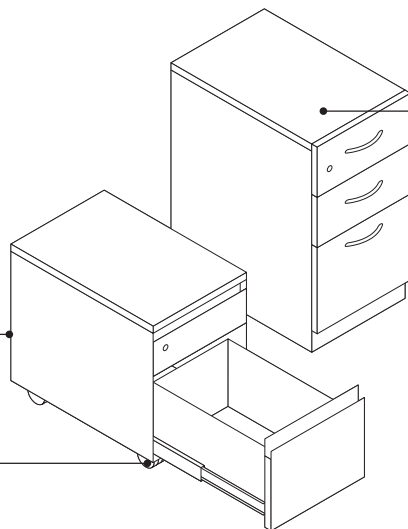

**Mobile pedestal cushion top** provides a temporary seat ideal for informal gatherings. Optional handle can be extended to easily transport mobile pedestal. Available factory- or field-installed.  
▶ Specifying, page 294

## Product Details

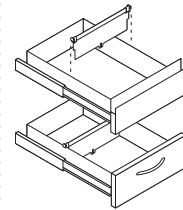

**Box drawers** are a welded steel construction and available with proud or flush fronts. One divider is included with each box drawer.

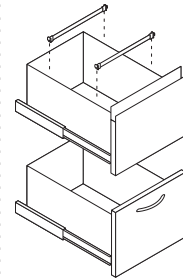

**File drawers** are a welded steel construction and available with proud or flush fronts. Drawer body sides are full height and accommodate front-to-back filing of hanging letter-size file folders.

**Optional rails** accommodate side-to-side filing of letter-, A4-, and legal-size hanging folders.  
*Exception: Legal-size file folders cannot be filed in 17 1⁄8"D or 18 3⁄8"D pedestals.*

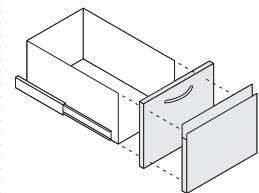

**Drawer fronts** can be removed and changed in the field to create a different aesthetic or to replace damaged drawer fronts.

## Actual Dimensions

	Fixed	Box/File	Box/Box/File and File/File
Depth with flush steel front	17 1⁄2", 22 5⁄8", and 28 5⁄8"	17 1⁄2" and 22 5⁄8"	17 1⁄2" and 22 5⁄8"
Depth with proud steel, laminate, or wood front	18 3⁄8", 23 1⁄2", and 29 1⁄2"	18 3⁄8" and 23 1⁄2"	18 3⁄8" and 23 1⁄2"
Width	15"	15"	15"
Height	25 1⁄2" and 27"	N.A.	N.A.
Overall height with 1⁄8"H top	N.A.	21"	27"

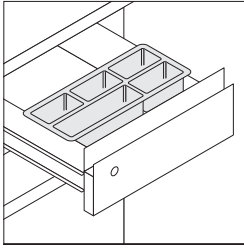

**Pencil tray** to hold small office supplies is included with each box/box/file pedestal.

**Optional basic drawer interior** allows box/box/file pedestals to be ordered without rails, box drawer dividers, or pencil trays.

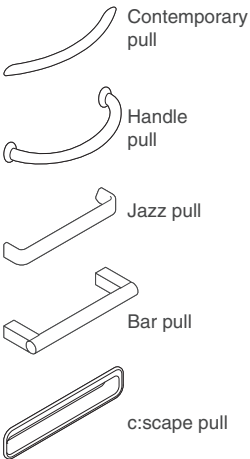

**Proud-front pulls** are available in the following styles—contemporary, handle, jazz, and bar. Each pull is 128 mm and available on steel or wood veneer drawers. c:scape pulls (200 mm) are available on steel drawers only.

**Label holders** are available through Service Parts. Label holder fits inside the integral pull of flush-front drawers and over the top edge of drawer front on proud-front drawers.

**Safety interlock system** allows only one drawer to be opened at a time for added stability.

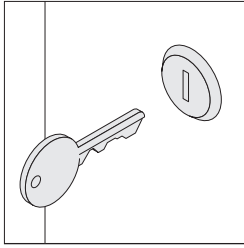

**Locks** are available factory- or field-installed. Factory-installed locks are standard and available keyed random only. Optional field-installed locks are available with consecutive, specific, and random keying options. Master-keyed locks are also available. Field-installed lock cylinders must be specified separately.

▶ *Lock and Keying*, page 375

**Individual drawer locks** are available on file/file pedestals for applications where you want to limit access to each drawer. Pedestals include a security shield above each drawer to prevent unauthorized access. Individual locking drawers are only available with field-installed lock cylinders. Consecutive, specific, and random keying options are available. Master-keyed locks are also available. Field-installed lock cylinders must be specified separately.

▶ *Lock and Keying*, page 375

**Non-locking pedestal** is available as an option.

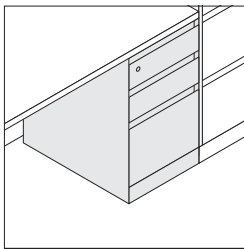

**27"H fixed pedestals** have base alignment with other Universal Storage components that have a 3"H base.

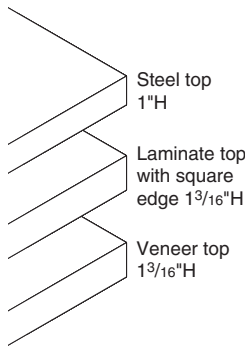

**Steel, laminate, and wood veneer tops** are available in place of standard 1/8"H steel tops, 1"H steel tops, 1 3/16"H laminate with square edge profile, and 1 3/16"H wood veneer with square edge profile.

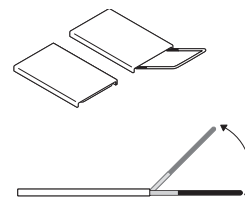

**Handle of mobile pedestal cushion top** is retractable. In the stowed position, handle is flush with mobile pedestal front. In the travel position, handle is completely extended and articulates upward for longer distance transport. Cushion top is also available without a handle.

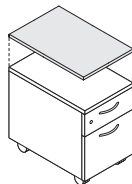

**Basic cushion enhanced** is ordered separately for use on Universal mobile pedestals with metal, laminate, or veneer top. Basic cushion enhanced is field-installed and attaches to the existing top with hook and loop fastener.

**Basic cushion enhanced for field installation** can be used with mobile pedestals RPM1821CF, RPM1821CP, RPM1821CW, RPM2421CF, RPM2421CP, and RPM2421CW only.

**Counterweight packages** are required to ensure product stability and are ordered as an option or separately. Product specification pages indicate the correct counterweight package for each style number and any exceptions where counterweights are not required.

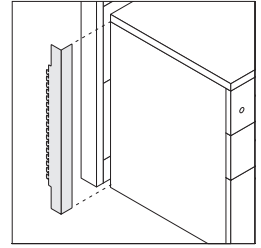

**Filler** conceals the gap that may exist between the face of a panel and the back of a 27"H pedestal. Fillers are also used to provide stability for pedestal and worksurface configurations that are not panel-wrapped.

*Tip: Fillers for proud front pedestals conceal a 1/2" gap. Fillers for flush front pedestals conceal a 1 3/8" gap.*

### Connections

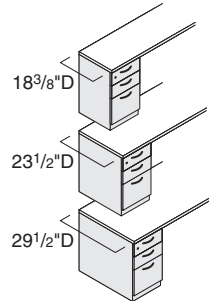

**Fixed pedestals** are intended to attach under a worksurface for security and support. Three pedestal depths are available to correspond with Universal Worksurface depths. Proud-front pedestals exactly match the depth of Universal Worksurfaces. Flush-front pedestals are 7/8" shorter.

**Freestanding applications** that don't require attachment to a worksurface should be used with a conversion kit that includes a steel top, counterweight package, and components to convert the locking system to a safety interlock system.

▶ Page 291

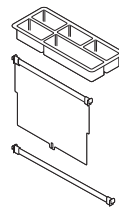

**Field-installed accessories** are available, including pencil trays, media trays, stationery trays, dividers, and rails.

### Wiring & Cabling

**Fixed pedestals** do not accommodate cable-routing. Plan accordingly when installing pedestals underneath worksurfaces with grommets or other cable-routing accessories.

### Surface Materials

#### Pedestal, steel drawer fronts, and integral pulls

- Paint

#### Contemporary, handle, jazz, and bar pulls

- 0835 Black
- 9201 Polished Chrome
- 9211 Nickel
- 9212 Silver

#### cscape pull

- 4140 Arctic White Gloss
- 4144 Black Gloss
- 4799 Platinum Metallic

#### Wood veneer top and drawer fronts

- Wood veneer—  
Open pore finishes
- Customiz stain (option)

#### Lock

- 9201 Polished Chrome
- 9250 Ember Chrome (option)

#### Drawer bodies, drawer suspensions, rails, dividers, and glides

- Black

#### Laminate top and drawer fronts

- Laminate
- Open Line laminate (option)

#### Square edge profile on laminate top

- Plastic

#### Cushion top

- Fabric
- Leather

#### Basic cushion enhanced

- Fabric

*Tip: For both cushion top and basic cushion enhanced: fabric patterns with a linear design will always be applied from the front to back of the unit or the depth of the unit. Pattern matching will not be done on COM.*

### Application Topics

#### Storage Capacities and Dimensions

▶ See *Storage Specification Guide*.

#### Counterweight Requirements for Storage Products

▶ Page 111.

### Shipping

**Pedestals** are normally shipped in heavy-duty, recyclable stretch wrap to reduce the amount of corrugated board needed.



# Universal Sliding Door Bins

For Use with Kick

**Universal sliding door bins** attach to panels with an on-module bracket and provide overhead storage in the work space. Door is available in steel or wood.  
 ▶ Specifying, page 296

**Safety catch locks** overhead storage unit to frame to prevent accidental removal.

**On-module attachment brackets** are used to mount bins on panels of the same width as bins and are included with the bin as a standard component.

**Steel, laminate, and wood front doors** glide smoothly from one side of the case to the other.

**Bin** ships assembled.

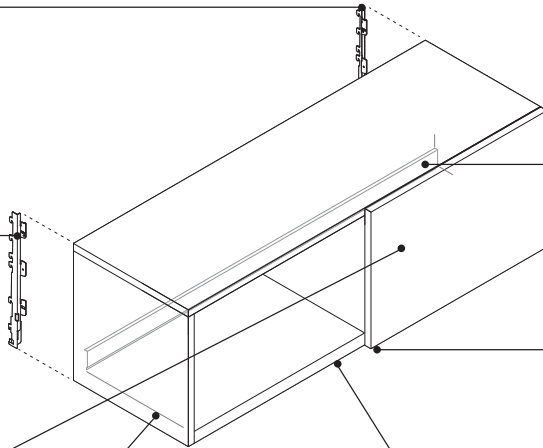

**Metal backstop** prevents notebooks and equipment from damaging panel surface.

**Lock** is standard on bins to secure the door. The door can be locked in the closed position on either the right- or left-hand side of the bin. Lock is located underneath the center of the shelf. Lock is standard factory-installed, keyed random. A no-lock option is available.  
 ▶ Lock and Keying Options, page 375

**Recess** beneath unit can accommodate a shelf light.  
 ▶ Page 340

## Product Details

**On-module attachment brackets** are independent of the storage bin and unique to the panel system they are used on. If the storage bin needs to be attached to a different panel in the future, additional on-module attachment brackets can be purchased through Service Parts.

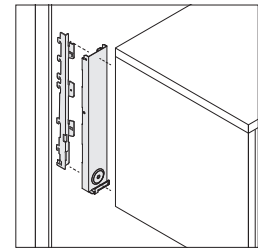

**Vertical off-module brackets**, optional, can be used to mount one or two sides of an overhead bin off-module on Answer, Kick, Avenir, and Montage with vertical slot patterned panels. To mount an overhead bin with one side off-module, specify with one vertical off-module bracket. To mount an overhead bin with two sides off-module, specify with two vertical off-module brackets. Both of these brackets attach to the on-module bracket that comes standard with the overhead bin.

**Vertical off-module brackets** are used with bins up to 12" wider than the panel, allowing them to overhang the panel seam.

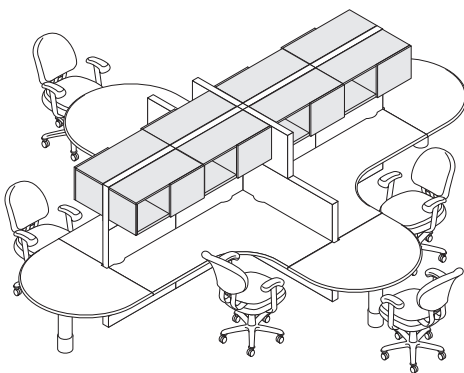

## Actual Dimensions

<b>Depth</b>	15 <sup>3</sup> / <sub>4</sub> "
<b>Width</b>	36", 42", 48", 60", 66", and 72"
<b>Height</b>	16 <sup>1</sup> / <sub>4</sub> "

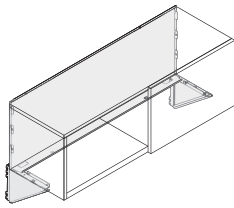

**Upmount brackets**, optional, are for use on Answer, Kick, Avenir, and Montage. Brackets enable overhead storage to be used on lower panel heights. Bins using an upmount bracket must be installed on a panel of the same width.

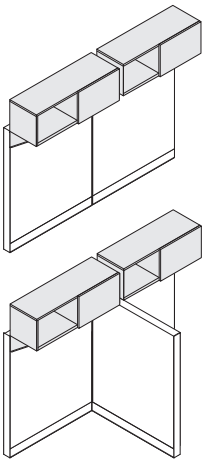

**Two upmount bin brackets** can be hung side-by-side in an in-line, T-, or X- application. Bin can be upmounted on slat-wall skin as long as there is not another bin or another slatwall skin on the adjacent in-line panel.

**Omit brackets option** must be specified when bin is being used in hutch kit or when attaching bin to a horizontal wall attachment bracket. Order hutch kit separately.

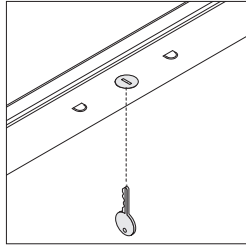

**Lock in bin** is concealed from view beneath the shelf. Locks are available factory- or field-installed. Factory-installed locks are standard and available keyed random only. Optional field-installed locks are available with consecutive, specific, and random keying options. Master-keyed locks are also available. Field-installed lock cylinders must be specified separately.

► *Lock and Keying*, page 375

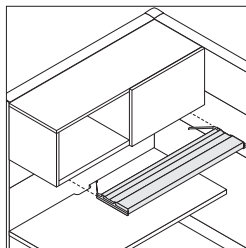

**Shelf lights** are available for use beneath bins. Lights recess into the bottom of the overhead storage unit.

► Page 340

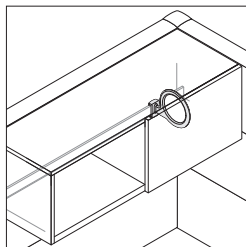

**Dividers** are available as an option for use on bins. Dividers ship in a package of four.

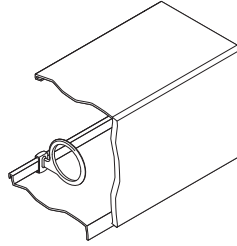

**Back of storage bin** is open to allow panel surface to show. Metal backstop prevents contents of bin from damaging panel surface.

**Overhead storage bin height** accepts standard and A4 binders.

**When mounting on Answer or Kick panels**, top of bin cannot be loaded.

### Connections

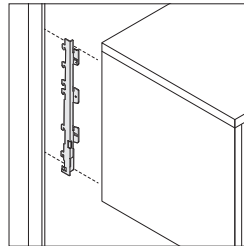

**Steel support** hooks on end supports insert into the slotted channel of a panel or wall channel and lock into place with a safety catch.

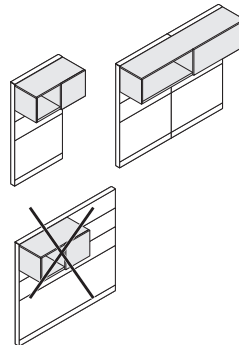

**Width of overhead bin** must match the width of the panel or panels that it is attached to when using an on-module bracket. Bin may span up to two frames.

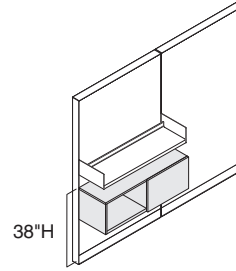

**Universal sliding door bin** may be mounted at 38"H or lower if another panel-mounted component prevents it from being seated upon.

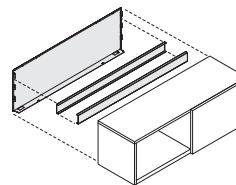

**Horizontal wall attachment brackets** are available to attach storage bins to wall of building. Specify as separate style number.

*Tip: Select the omit brackets option when ordering the bin.*

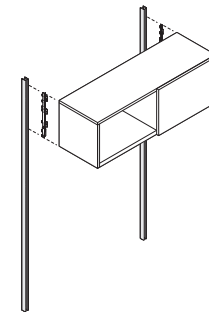

**Wall channels** are available to attach bins to concrete or block walls. Wall channels can be used to attach bins and tackboards to wood, dry wall, or plaster walls if the wall is reinforced.

► Page 156

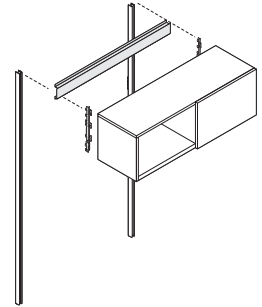

**Wall channel horizontal brace** is required with wall channels to support bins that are wider than 48".

► Page 156

### Wiring & Cabling

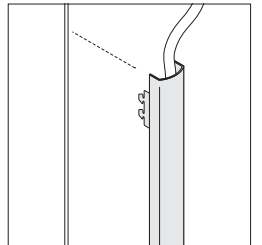

**Vertical wire managers** are available to conceal cords that are routed from light mounted beneath overhead storage.

► Page 350

### Surface Materials

#### Overhead bin

- Paint
- Wood door (optional)

#### Locks

- 9201 Polished Chrome
- 9250 Ember Chrome (optional)

#### On-module and vertical off-module attachment brackets

- Black paint only

#### Upmount brackets

- Paint

#### Dividers

- White plastic

**Application Topics**

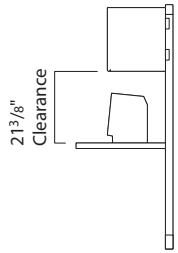

**Clearance** between Universal Systems Worksurfaces or Universal tables and bottom of overhead bins is 2 13/8" when storage unit is installed in the highest position on a 66"H panel and glides are adjusted all the way into the panel.

**Storage Capacities and Dimensions**

▶ See *Storage Specification Guide*.

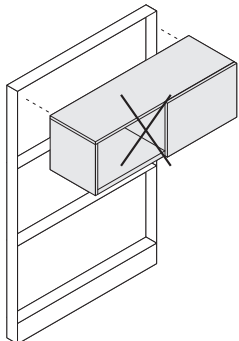

**Hanging components** cannot be hung in front of a double-pane window.

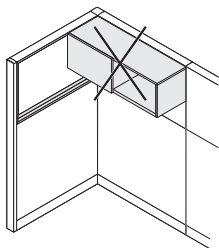

**Hanging components** cannot be used next to a double-pane window at a 90 degree corner.

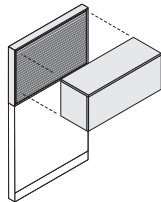

**Overhead bins** can be hung in front of slatwall skins.

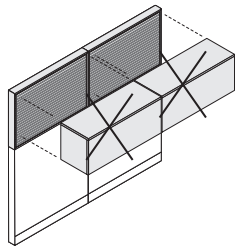

**Two bins** cannot be hung side by side if one or both bins are in front of a slatwall skin.

**Bracket Application Rules for Bins and Shelves**

▶ Page 158

**Stability Guidelines**

▶ Page 26

**Guidelines for Stackable Components**

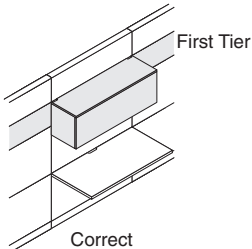

Correct

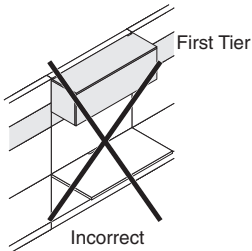

Incorrect

**TS Series bins, Universal bins, and shelves** can hang from the first stacked tier only.



# Universal Over the Case and In the Case Bins

For Use with Kick

**Universal over the case bins** can be attached to panels with an on-module bracket and provide overhead storage in the work space.

► Specifying, page 298

**Safety catch** locks overhead storage unit to frame to prevent accidental removal.

**On-module attachment brackets** are used to mount bins on panels of the same width as bins and are included with the bin as a standard component.

**Backstop** prevents notebooks and equipment from damaging the surface of the panels or walls.

**Bin** is steel and ships assembled.

**Universal in the case bins**, attach to panels with an on-module bracket and provide overhead storage in the work space. Door is available in steel, laminate, or wood.

► Specifying, page 300

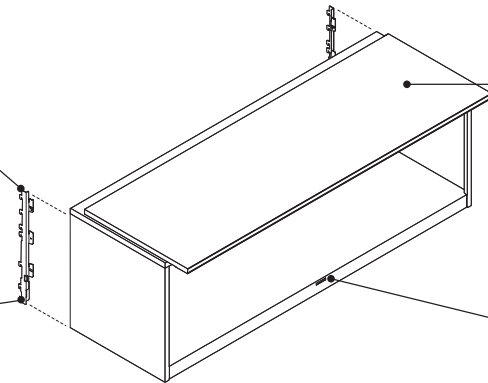

**Flat-front lift-up doors** open and close quietly. When up, the doors rest on top of the case to provide more storage space inside.

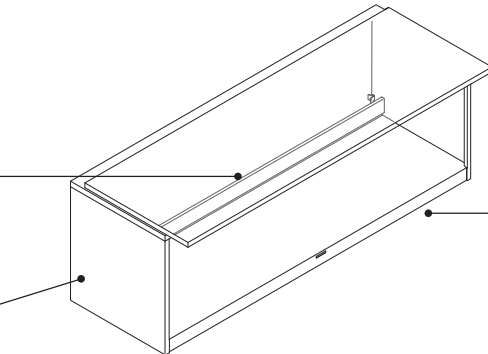

**Locks** are standard on bins to secure the door(s). Lock is located underneath the center of the shelf. Locks are standard factory-installed, keyed random. Two-door units are keyed alike. A no-lock option is available.

► *Lock and Keying*, page 375

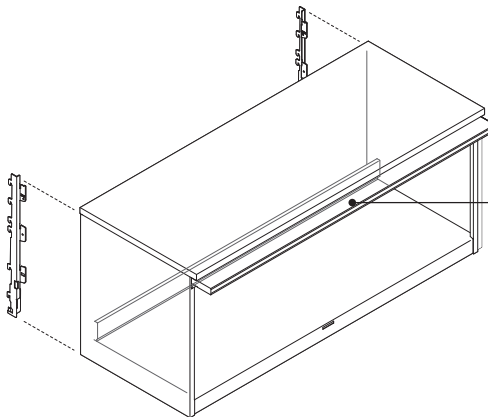

**Flat-front lift-up doors** (steel, laminate, or wood) recess into the overhead storage bin.

## Product Details

**On-module attachment brackets** are independent of the storage bins and unique to the panel system they are used on. The following style number suffixes indicate the panels they attach to:

**TAK** = Answer and Kick  
**AVR** = Avenir

**MON** = Montage

If the storage bin needs to be attached to a different panel in the future, additional on-module attachment brackets can be purchased through Service Parts.

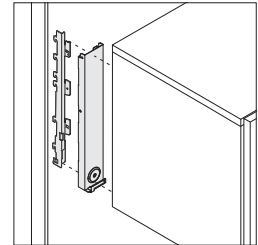

**Vertical off-module brackets**, optional, can be used to mount one or two sides of an overhead bin off-module on Answer, Kick, Avenir, and Montage with vertical slot patterned panels. To mount an overhead bin with one side off-module, specify with one vertical off-module bracket. To mount an overhead bin with two sides off-module, specify with two vertical off-module brackets. Both of these brackets attach to the on-module bracket that comes standard with the overhead bin.

**Vertical off-module brackets** are used with bins up to 12" wider than the panel, allowing them to overhang the panel seam.

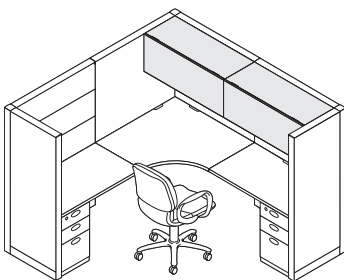

## Actual Dimensions

<b>Depth</b>	15 <sup>3</sup> / <sub>4</sub> "
<b>Width</b>	24", 30", 36", 42", 48", 60", 66", and 72"
<b>Height</b>	16 <sup>1</sup> / <sub>4</sub> "

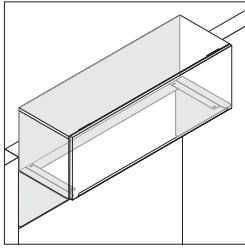

**Picture frame door—omit insert**, optional, is available on Universal over the case and in the case bins with flat steel fronts only. An omit insert option allows custom material to be field installed in the aluminum door frame.

**Upmount brackets** are optional for use on Answer, Kick, Avenir, and Montage. Brackets attach the bin near the top of 54"H panel to enable overhead storage to be used on lower panel heights. Bins using an upmount bracket must be installed on a panel of the same width.

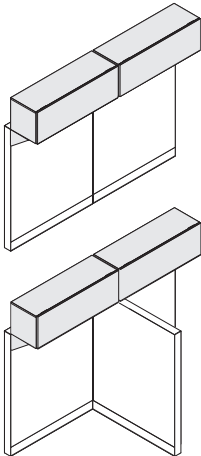

**Two upmount bin brackets** can be hung side by side in an in-line, T-, or X-application. Bin can be upmounted on slatwall skin as long as there is not another bin or another slatwall skin on the adjacent in-line panel.

**Omit brackets option** must be specified when bin is being used in hutch kit or when attaching bin to a horizontal wall attachment bracket. Order hutch kit separately.

**The omit insert custom material** must be ordered from a material vendor. If an omit insert option is specified and a door assist mechanism is also required, an assist mechanism must be specified as a separate option to the storage bin. The weight of a custom insert on a Universal over the case bin can not exceed 10½ pounds. An insert for a Universal over the case storage bin door with an assist mechanism must weigh within the range of 7¼ pounds to 10½ pounds or the assist mechanism will not function correctly. Custom materials being installed in a door insert must comply with local building codes. Consult with local authorities to determine compliance requirements. The use of safety glass is required if installing custom glass in a door insert. To install customer provided material in a picture frame door with the insert omitted, make sure the material is cut precisely to the sizes listed on the dimensions matrix.   
▶ See *Dimensions for Custom Field-Installed Picture Frame Door Inserts*, page 151

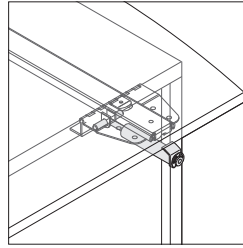

**Door assist mechanism**, optional, consist of a gas cylinder and spring that provides an assisted open and close of the door. When opening the door, the spring pulls the door to the fully recessed position. When closing the door, the assist mechanism will slowly close the door. Universal bins ship with two assist mechanisms per door when specified.

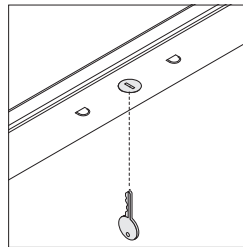

**Lock in bin** is concealed from view beneath the shelf. Locks are available factory- or field-installed. Factory-installed locks are standard and available keyed random only. Two-door units are keyed alike. Optional field-installed locks are available with consecutive, specific, and random keying options. Master-keyed locks are also available. Field-installed lock cylinders must be specified separately.   
▶ *Lock and Keying*, page 375

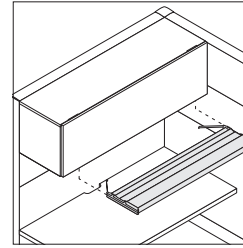

**Shelf lights** are available for use beneath bins. Lights recess into the bottom of overhead bins.   
▶ Page 340

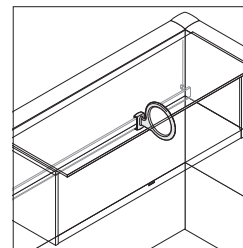

**Divider** is available as an option on overhead bins. Dividers ship in a package of four.   
▶ Page 164

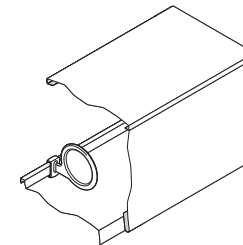

**Back of storage bin** is open to allow panel surface to show. Metal backstop prevents contents of bin from damaging panel surface.

**Overhead storage bin height** accepts standard and A4 binders.

**When mounting on Answer or Kick panels**, top of bin cannot be loaded.

## Connections

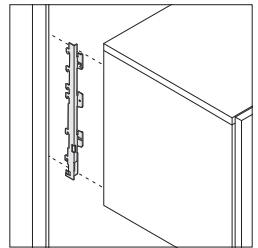

**Steel support hooks on end supports** insert into the slotted channel of a panel or wall channel and lock into place with a safety catch.

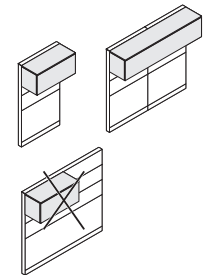

**Width of overhead bin** must match the width of the panel or panels that it is attached to when using an on-module bracket. Bin may span up to two frames.

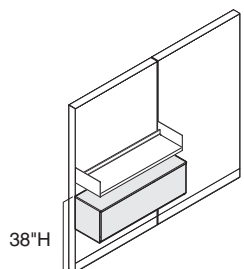

**Universal over the case bin** may be mounted at 38"H or lower if another panel-mounted component prevents it from being seated upon.

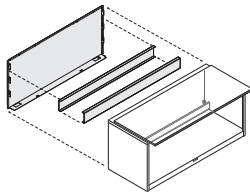

**Horizontal wall attachment brackets** are available to attach storage bins to wall of building. Specify as a separate style number.  
*Tip: Select the omit brackets option when ordering the bin.*  
 ▶ Page 304

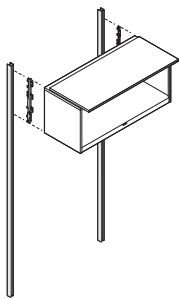

**Wall channels** are available to attach bins to concrete or block walls. Wall channels can be used to attach bins and tackboards to wood, dry wall, or plaster walls if the wall is reinforced.  
 ▶ Page 156

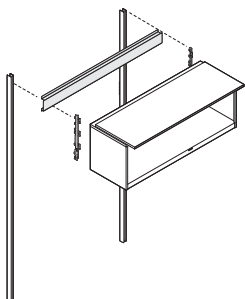

**Wall channel horizontal brace** is required with wall channels to support bins that are wider than 48".  
 ▶ Page 156

**Wiring & Cabling**

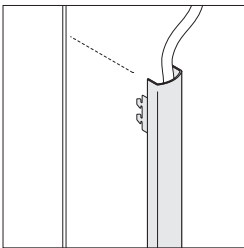

**Vertical wire managers** are available to conceal cords that are routed from light mounted beneath overhead storage.  
 ▶ Page 350

**Surface Materials**

**Overhead bin**

- Paint

**Lock**

- 9201 Polished Chrome
- 9250 Ember Chrome (optional)

**On-module and vertical off-module attachment brackets**

- Black paint only

**Horizontal off-module attachment brackets for Montage**

- Paint to match bin

**Upmount brackets**

- Paint

**Dividers**

- White plastic

**Application Topics**

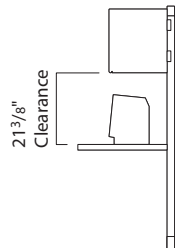

**Clearance** between worksurfaces and bottom of overhead bins is 21<sup>3</sup>/<sub>8</sub>" when storage unit is installed in the highest position on a 66"H panel and glides are adjusted all the way into the panel.

**Storage Capacities and Dimensions**

▶ For interior dimensions, see *Storage Capacities and Dimensions* in the *Storage Specification Guide*.

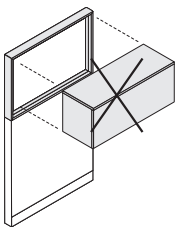

**Hanging components** cannot be hung in front of a double-pane window.

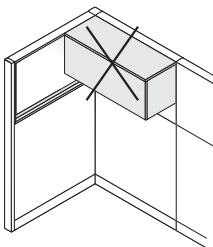

**Hanging components** cannot be used next to a double-pane window at a 90 degree corner.

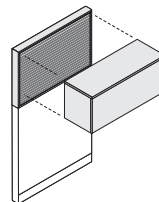

**Overhead bins** can be hung in front of slatwall skins.

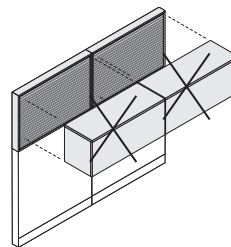

**Two bins** cannot be hung side by side if one or both bins are in front of a slatwall skin.

**Bracket Application Rules for Bins and Shelves**

▶ Page 158

**Guidelines for Stackable Components**

**TS Series bins, Universal bins, and shelves** can hang from first or second stacked tier as long as it is not above 66"H.

**Only TS Series bins, Universal over the case bins or shelves** can be supported on the second stacked tier.

# Dimensions For Custom Field-Installed Picture Frame Door Inserts

Dimensions For Custom  
Field-Installed Picture  
Frame Door Inserts

Universal Storage

## For Universal Over the Case Bins

Bin Width	Door Width	Custom Picture Frame Door Inserts		
		Height +/-0.02"	Width +/-0.02"	Thickness +/-0.02"
24"	24"	15.933"	23.314"	0.138"
25"	25"	15.933"	24.314"	0.138"
30"	30"	15.933"	29.314"	0.138"
35"	35"	15.933"	34.314"	0.138"
36"	36"	15.933"	35.314"	0.138"
42"	42"	15.933"	41.314"	0.138"
45"	45"	15.933"	44.314"	0.138"
48"	48"	15.933"	47.314"	0.138"
60"	30" (per door)	15.933"	29.314"	0.138"
66"	33" (per door)	15.933"	32.314"	0.138"
70"	35" (per door)	15.933"	34.314"	0.138"
72"	36" (per door)	15.933"	35.314"	0.138"
75"	37½" (per door)	15.933"	36.314"	0.138"

*Tip: A custom insert cannot be factory installed. Custom insert must be ordered from a material vendor and will not be handled like a Steelcase Customer's Own Material. In selecting materials for customer supplied inserts, consider material characteristics, such as effects from thermal changes, humidity changes, aging characteristics, and strength of material. Do not use materials that allow the overall size of the custom insert to deviate by amounts larger than the acceptable tolerances listed in the matrix.*

## For Universal In the Case Bins

Bin Width	Door Width	Custom Picture Frame Door Inserts		
		Height +/-0.02"	Width +/-0.02"	Thickness +/-0.02"
24"	24"	15.000"	23.164"	0.138"
25"	25"	15.000"	24.164"	0.138"
30"	30"	15.000"	29.164"	0.138"
35"	35"	15.000"	34.164"	0.138"
36"	36"	15.000"	35.164"	0.138"
42"	42"	15.000"	41.164"	0.138"
45"	45"	15.000"	44.164"	0.138"
48"	48"	15.000"	47.164"	0.138"
60"	30" (per door)	15.000"	29.164"	0.138"
66"	33" (per door)	15.000"	32.164"	0.138"
70"	35" (per door)	15.000"	34.164"	0.138"
72"	36" (per door)	15.000"	35.164"	0.138"
75"	37½" (per door)	15.000"	36.664"	0.138"

*Tip: A custom insert cannot be factory installed. Custom insert must be ordered from a material vendor and will not be handled like a Steelcase Customer's Own Material. In selecting materials for customer supplied inserts, consider material characteristics, such as effects from thermal changes, humidity changes, aging characteristics, and strength of material. Do not use materials that allow the overall size of the custom insert to deviate by amounts larger than the acceptable tolerances listed in the matrix.*

# Universal Shelves and Universal Personal Shelves

For Use with Kick

**Universal shelves**—supported by Answer, Kick, Avenir, and Montage—provide overhead storage in the work space.  
▶ Specifying, page 303

**Universal personal shelves** provide a wall-supported surface that attaches to Answer, Kick, and Avenir.  
▶ See *Storage Specification Guide*.

**Metal backstop on Universal shelves** prevents notebooks and equipment from damaging panel surface. Universal personal shelves do not have a backstop.

**On-module attachment hooks** are integral to the end supports and are used to mount shelves on panels of the same width as bins.

**Safety catch** locks shelf units to frame to prevent accidental removal.

**Shelves** are steel and ship ready to assemble.

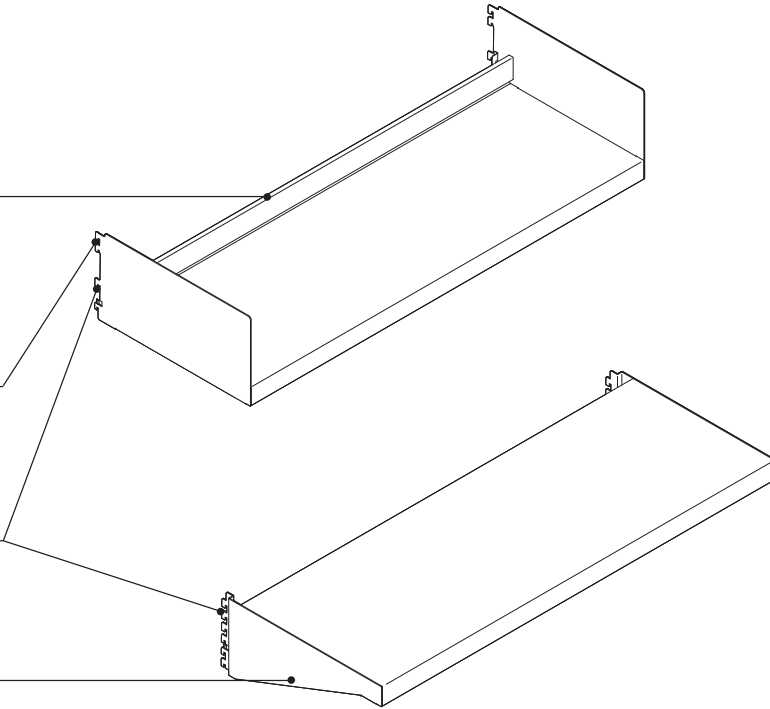
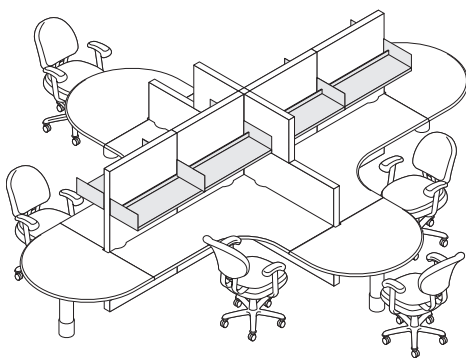

## Product Details

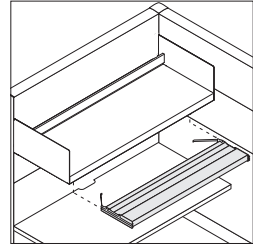

**Shelf lights** are available for use beneath shelves. Lights recess into the bottom of the overhead storage unit.  
▶ Page 340

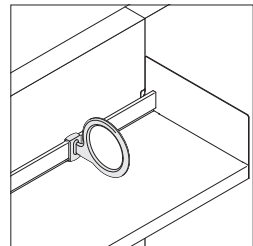

**Dividers** are available field installed for use on Universal shelves. Dividers ship in a package of four. Dividers cannot attach to Universal personal shelves.

**A 1½" gap** exists between the personal shelf and the panel to allow for cable routing.

**The height dimension of the bracket** (from top of personal shelf to the bottom of the bracket) is 6½" H.

## Connections

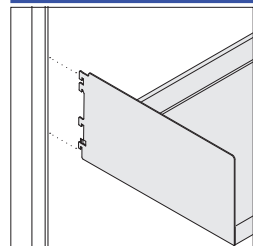

**Steel support hooks** on end supports insert into the slotted channel of a panel or wall channel and lock into place with a safety catch.

## Actual Dimensions

	Universal shelves	Universal personal shelves
Depth	14¾"	13¹¹⁄₁₆"
Width	24", 30", 36", 42", 48", 60", and 72"	24", 30", 36", 42", and 48"
Height	7½" (Kick, Answer, and Avenir)	1¹¹⁄₁₆" (thickness of shelf)

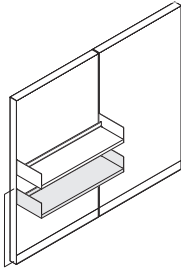

38"H

**Universal shelf** may be mounted at 38"H or lower if another panel-mounted component prevents it from being seated upon.

**On-module attachment hooks** cannot be attached to upmount brackets.

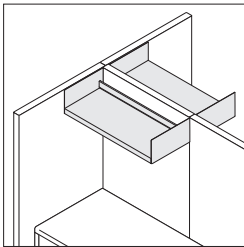

**Width of shelf** must match the width of the panel or panels that it is attached to with the on-module brackets. Shelves may span up to two frames.

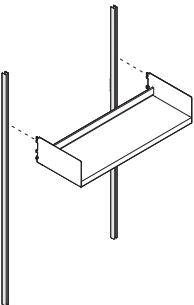

**Wall channels** are available to attach shelves to concrete or block walls. Wall channels can be used to attach shelves to wood, dry wall, or plaster walls, if wall is reinforced.

▶ Page 156

### Wiring & Cabling

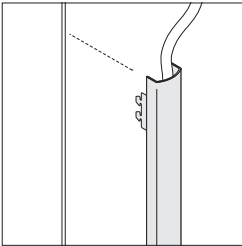

**Vertical wire managers** conceal cords and cables that are routed vertically outside of the panels.

▶ Page 350

### Surface Materials

#### Shelf

- Paint

### Application Topics

#### Storage Capacities and Dimensions

▶ For interior dimensions, see *Storage Capacities and Dimensions* in the *Storage Specification Guide*.

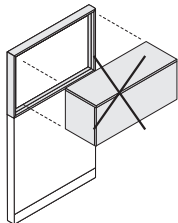

**Hanging components** cannot be hung in front of a double-pane window.

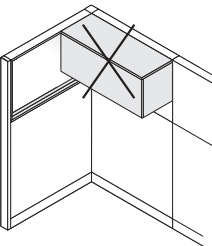

**Hanging components** cannot be used next to a double-pane window at a 90 degree corner.

#### Bracket Application Rules for Bins and Shelves

▶ Page 158

### Stability Guidelines

▶ Page 26

### Guidelines for Stackable Components

**TS Series bins, Universal bins, and shelves** can hang from first or second stacked tier as long as it is not above 66"H.

**Only TS Series bins, Universal over the case bins or shelves** can be supported on the second stacked tier.

# Dividers

## Dividers



► Specifying, page 304

### Product Details

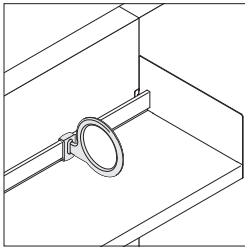

**Divides** space in panel-supported bins and Universal shelves. Dividers will not work in bins and shelves introduced prior to March 2007.

**Divider** can be used on hutch kit.

### Specifying

**A carton of four dividers** is available as an option on overhead bins and Universal shelves.

### Surface Materials

**Divider**

- White plastic only

### Actual Dimensions

<b>Depth</b>	7½"
<b>Width</b>	¼" 1½" at the back
<b>Height</b>	6½"

# Horizontal Wall Attachment Brackets

For Use with Universal Sliding Door, Universal Over the Case, and Universal In the Case Bins

Horizontal Wall Attachment Brackets

Universal Storage

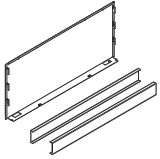

**Horizontal wall attachment brackets** can attach to wall of building to accept Universal sliding door, Universal Over the Case, and Universal In the Case storage bins. Brackets will not accept bins introduced prior to March 2007 or TS Series bins.

► Specifying, page 304  
 Tip: Specify as a separate style number.

## Product Details

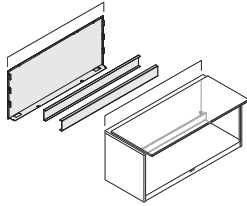

**Horizontal wall attachment brackets** must match the width of the storage bin.

Tip: Select the omit brackets option when ordering the bin.

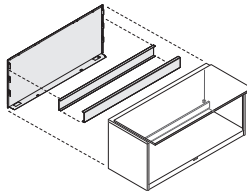

**Horizontal wall attachment brackets** include brackets and a steel back to enclose the storage bin.

**Horizontal wall attachment brackets** can be positioned on wall at height needed.

## Connections

**Horizontal wall attachment brackets** can be used to attach Universal sliding door, Universal over the case, and Universal in the case bins to a building wall. TS Series bins cannot attach to horizontal wall attachment brackets.

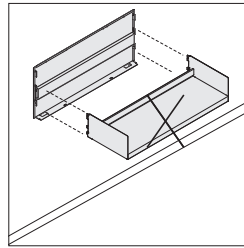

**Shelves** cannot hang off horizontal wall attachment brackets.

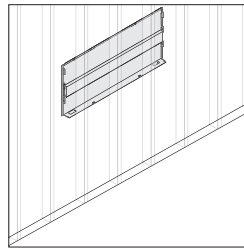

**Mounting** of horizontal wall attachment brackets must include attachment to at least two wall studs, but it is recommended to attach to all studs in wall behind the storage bin. Storage bins that are 24"W or 25"W can only be mounted with horizontal wall attachment brackets if wall is constructed with 16" stud centers.

## Field install:

- Concrete walls with Hilti type anchors.
- Drywall or plywood with  $\frac{5}{8}$ " thick Toggler R-type  $\frac{3}{16}$ " wall anchors with countersunk flat head screw.
- Wood studs with #10 wood screws of appropriate length with countersunk flat head screw.
- Steel studs with #10 sheet metal screws of appropriate length with countersunk flat head screw.

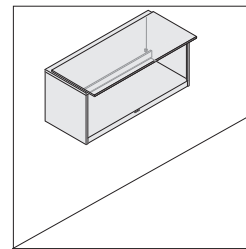

**Limit** of one bin for each horizontal wall attachment bracket.

**Attaching worksurfaces** to horizontal wall attachment brackets is not possible.

**Horizontal wall attachment brackets** allow overhead storage bin to fit flush to wall.

## Actual Dimensions

**Width** 24", 30", 36", 42", 48", 60", 70", and 72".

## Surface Materials

### Brackets and steel back

- Paint

# Wall Hang Channels and Horizontal Braces

For Use with Overhead Storage Bins and Shelves

**Slotted steel channel** can attach to wall of building to accept shelves, overhead storage bins, worksurfaces, or tackboards. Channel will accept all universal bins and shelves, TS Series bins and bins and shelves introduced prior to March 2007.

► Specifying, page 306

*Tip: Must specify bin or shelf with Answer, Kick, or Avenir bracket to hang on wall channel.*

## Product Details

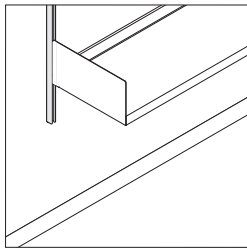

**Wall channel** can be positioned on wall at height needed.

## Connections

**Wall channels** can be used to support shelves, overhead storage bins, worksurfaces, and tackboards. Wall channels can be shared.

### Field install:

- Concrete walls with Hilti type anchors.
- Drywall or plywood with  $\frac{5}{8}$ " thick Toggler R-type  $\frac{3}{16}$ " wall anchors with countersunk flat head screw.
- Steel or wood studs with #10 sheet metal or wood screws of appropriate length with countersunk flat head screw.

**Anchors** must be used in each screw hole location on the wall channel.

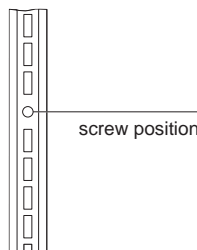

**Components attach** at 1" increments, but screws block some slot locations.

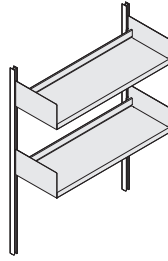

**Component limits for each pair of wall channels** are as follows:

- Two bins or shelves
- One worksurface and two shelves
- One worksurface and one bin

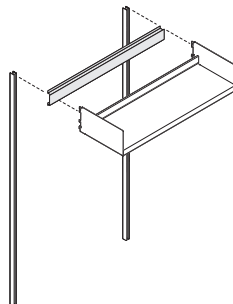

**Horizontal brace** is available to reinforce vertical wall channels that support storage bins, shelves, or worksurfaces that are attached to walls. Bins and shelves that are 48"W or less do not require a horizontal brace. All worksurfaces require horizontal braces.

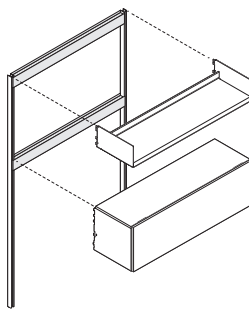

**Wall channel horizontal brace** is required for EACH storage bin or shelf that is wider than 48". The brace should be placed at the position along the vertical wall channel where the top of the bin or shelf will be placed.

**Width of horizontal brace** must match width of shelf or storage bin.

**Wall channel horizontal brace** is also available in 42" and 48" widths and can be used in applications where there is concern regarding the strength of the wall. These braces must also be used with wall-mounted worksurfaces.

**Wall hang channels** for shelves, overhead storage bins, or tackboards cannot be used with a wall start junction.

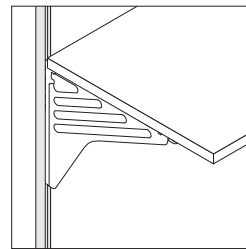

**Worksurfaces** may be attached to wall channels with cantilevers, subject to the following application guidelines:

- All worksurfaces must be 24"D or less.
- Worksurfaces must be supported by a cantilever or legs every 42" or 48". Cantilevers can be shared when worksurfaces are adjacent.
- Wall channel horizontal braces must be installed directly behind all wall-mounted worksurfaces, and also at the top of the wall channels.
- Worksurface-supported pedestals cannot be hung from a wall-mounted worksurface.

## Surface Materials

### Wall channel

- Paint

### Horizontal brace

- Paint

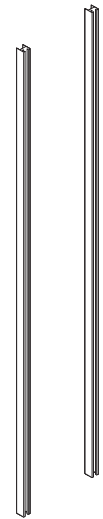

### Screw hole positions

$64\frac{3}{8}$ "H

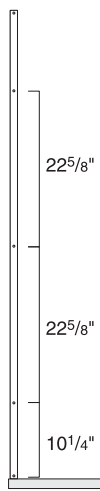

Floor

## Actual Dimensions

### Wall hang channels and horizontal braces

Depth	1 $\frac{1}{8}$ " (28 mm)
Width	1 $\frac{5}{16}$ " (24 mm)
Height	66" (1676 mm)

## Application Topics

**Reinforce** wall by positioning studs where wall channels will be attached. See dimensions below.

Distance between center lines of reinforced wall channels matches width of overhead storage unit.

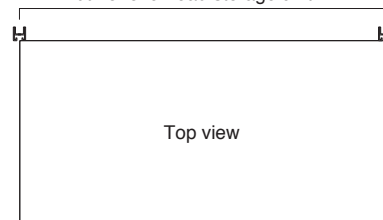

Top view

*Tip: Wall channels can be shared.*

**Slim shelves** provide a panel-supported surface that attaches to Kick with panel-specific brackets.

► Specifying, page 308

**Slim shelf** is an extruded aluminum shelf that provides storage for small items.

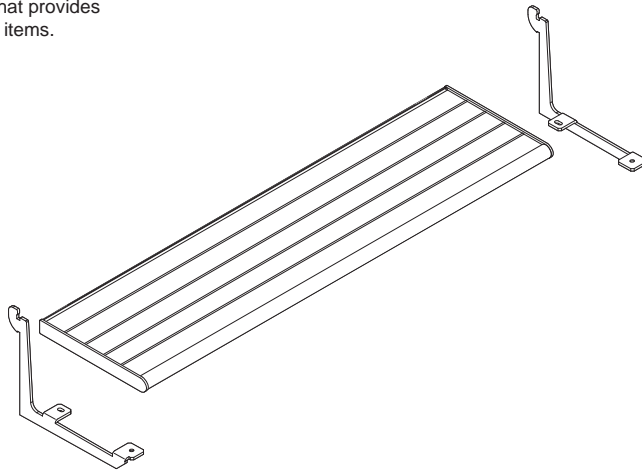

## Product Details

**Slim shelves** attach to Kick with panel-specific brackets.

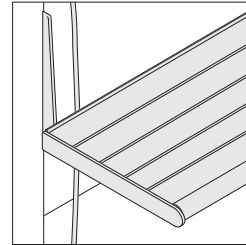

**Gap at back of slim shelf** allows routing of shelf light cord.

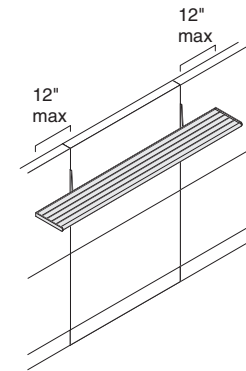

**Slim shelves** can be mounted off-module. No more than 12" overhang on either side of panel is recommended. Brackets attach on vertical seams of panel, while the shelf adjusts off-module on the brackets.

**Two attachment brackets** are included with shelves less than or equal to 48"W. Two attachment brackets and a mid-span support are included with shelves wider than 48"W.

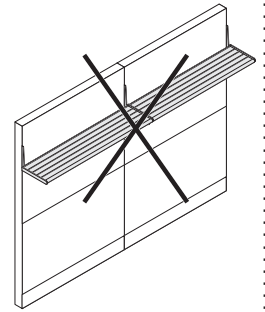

**Kick will not support** two shelves installed end to end.

## Surface Materials

**Slim shelves**

- Paint

**Attachment brackets**

- Painted to match shelf

## Actual Dimensions

**Depth** 6<sup>3</sup>/<sub>8</sub>"

**Width** 24", 30", 36", 42", 48", 60", 72", or 96"

# Bracket Application Rules for Bins and Shelves

For TS Series Bins, Universal Sliding Door Bins, Universal Over the Case Bins, Universal In the Case Bins, and Universal Shelves

## Bracket Application Matrix

Panels	TS Series Bins, Universal Bins, and Universal Shelves—On-Module	Universal Bins—Single Side Vertical Off-Module	Universal Bins—Two Sided Vertical Off-Module	Universal Bins—Horizontal Off-Module (for use with and Montage only)	Universal Bins—Upmount
Answer	●	●	●		●
Kick	●	●	●		●
Avenir	●	●	●		●
Montage	●	●	●	●	●

### On-Module Brackets and Hooks

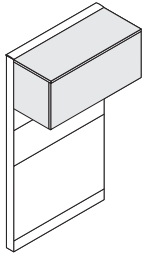

**On-module brackets and hooks** are used to mount overhead bins and Universal shelves to panels with vertical slot patterns. Answer, Kick, Avenir, and Montage panels can support on-module attachment brackets.

**Universal personal shelves** can attach on-module to all panels except Montage.

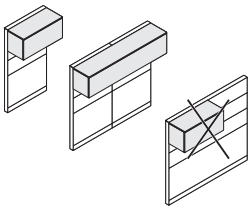

**Width of overhead storage unit** must match the width of the panel or panels that it is attached to. Storage bins or shelves may span up to two panels.

**Additional support** for stability may be required when shelves and overhead storage bins are attached to panels. Counterbalancing loads on the opposite sides of the panels increases stability.

*Tip: See Stability Guidelines in each corresponding specification guide.*

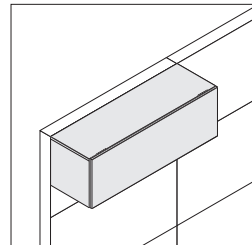

**On-module attachment brackets** install in panel seams.

**On-module brackets** can be used above and adjacent to slatwall on Answer and Montage Panels.

**On-module brackets** can be used with a panel stacker on Answer, Kick, and Montage panels. Follow standard panel stacker guidelines for each panel.

**Off-module brackets** are used with bins up to 12" larger than the panel, allowing them to overhang the panel seam.

### Off-Module Brackets

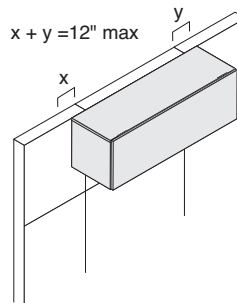
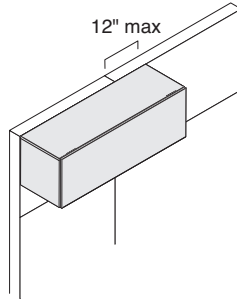

**Vertical off-module brackets, optional**, can be used to mount one or two sides of the overhead bin off-module on Answer, Kick, Avenir, and Montage with vertical-slot-patterned panels. Both of these brackets attach to the on-module bracket that comes standard with the overhead bin. Vertical off-module brackets allow bins to be installed a maximum of 12" off-module. Vertical off-module brackets can be used with 30"W to 60"W Montage bins only.

**Vertical off-module brackets** can be used above and adjacent to slatwall on Answer and Montage panels.

**Vertical off-module brackets** can be used with a panel stacker on Answer, Kick, and Montage panels. Follow standard panel stacker guidelines for each panel.

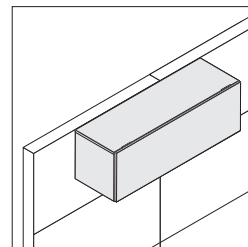

**Horizontal off-module brackets, optional**, accommodate off-module installations of overhead storage bins on panels with horizontal slot patterns. Enhanced off-module Montage frames can support horizontal off-module brackets. Horizontal off-module brackets can be used with 24"W to 48"W Montage bins only.

**Horizontal off-module brackets** can be used above and adjacent to slatwall on Montage panels.

**Horizontal off-module brackets** can be used with a panel stacker on Montage panels. Follow standard panel stacker guidelines for each panel.

**Enhanced off-module Montage frames** have horizontal slot patterns and must be specified for horizontal off-module Montage configurations.

**Horizontal off-module brackets** push bin out from panel 5/8" on enhanced off-module Montage panels.

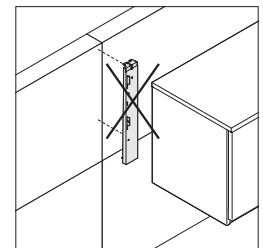

**Horizontal off-module brackets** cannot span a vertical or joint where two frames come together on enhanced off-module Montage panels. Shift the bin to avoid the joint.

**Only two pairs of off-module brackets** and associated storage can be mounted per frame.

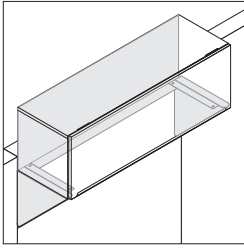

**Upmount brackets,** optional, can be used with Universal sliding door, Universal over the case, and Universal in the case bins. Brackets attach bins near the top of 54"H panels. TS Series bins and Universal shelves cannot be attached to upmount brackets.

**Upmount bin width** must match the width of the panel or panels that it attaches to. Upmounted bins and shelves cannot be supported off-module.

**Upmount brackets** can be used with a panel stacker on Answer, Kick, and Montage panels. Follow standard panel stacker guidelines for each panel.

### Omit Brackets

**Omit brackets option** must be specified when bin is used in hutch kit or when attaching bin to a horizontal wall attachment bracket. Order hutch kit separately. Hutch kit supports bin at 66" height.

# Application Rules for Overhead Storage on Answer and Kick Panels

Tip: For complete panel specific stability guidelines, see the corresponding panel specification guide.

## Answer Panel

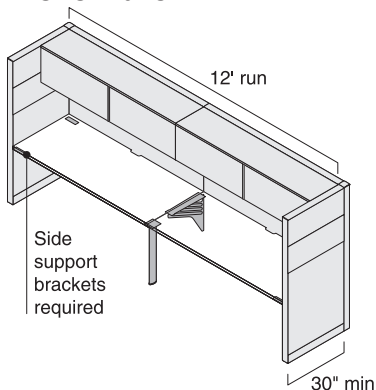

**Guidelines for Universal Bins.** Applies to universal sliding door bin or universal in the case bin on Answer and Kick panels.

**The following application restrictions** must be complied with when hanging universal overhead bins on Answer and Kick panels. Otherwise, standard Answer and Kick application guidelines apply.

- Universal sliding door bin or universal in the case bins cannot hang on an Answer or Kick panel above the 66"H connection point.
- Universal sliding door bin and universal in the case bins or shelves cannot hang on a stacked segment of an Answer panel.
- The maximum panel run length when using a universal overhead bin on Answer or Kick panels is 12'.
- Top of bins and shelves are not designed to support the weight of a seated person. Bins and shelves may be mounted at 38"H or lower only if another panel-mounted component prevents it from being seated upon.
- When ganging binder bins, the use of a tie plate is required.

### **WARNING**

Failure to comply to these guidelines may result in personal injury.

## Kick Panel

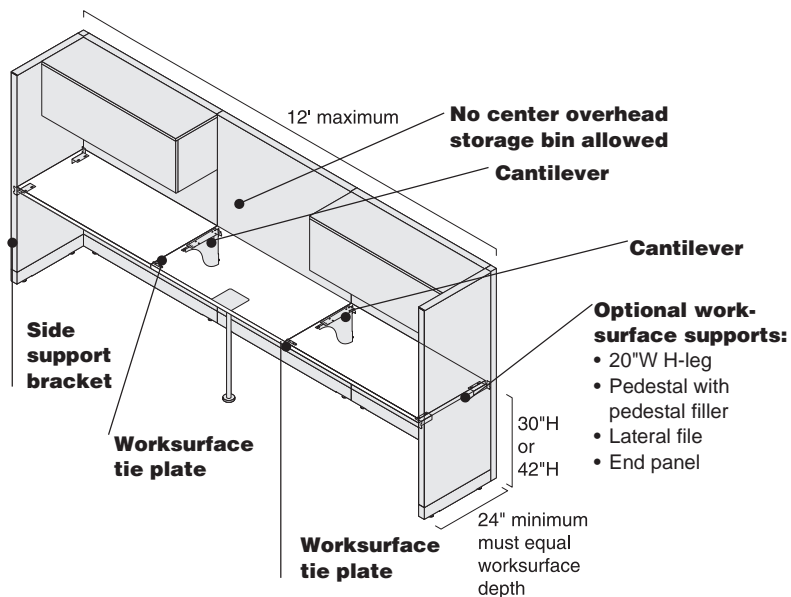
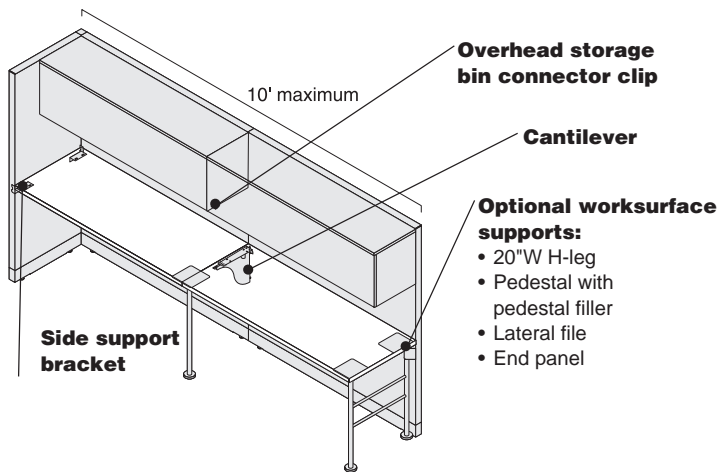



# Universal One-High, 1.5-High, and Two Drawer Lateral Files

## One-High and Two Drawer lateral files

serve a dual purpose as high-density storage and as an inviting space for guests.

► Specifying, page 310

## 1.5-High lateral files

provide multi-zone storage for binders, hanging folders, and piling surfaces at a height which allows for comfortable guest seating in collaborative environments.

► Specifying, page 310

## Label holders

are included with each drawer. Label holder fits inside the integral pull or can be affixed to the front of the drawer or door. Perforated labels are included and can be created using the template available on [www.steelcase.com/label](http://www.steelcase.com/label).

**Finished back** is standard.

## Three base options

**are available:** the universal 3" base, FrameOne foot, and c:scape glide. All three bases have the same overall height.

**Lock** is standard on lateral files and is located at top left corner of drawer. Locks are standard factory-installed, keyed random.

► *Lock and Keying*, page 375

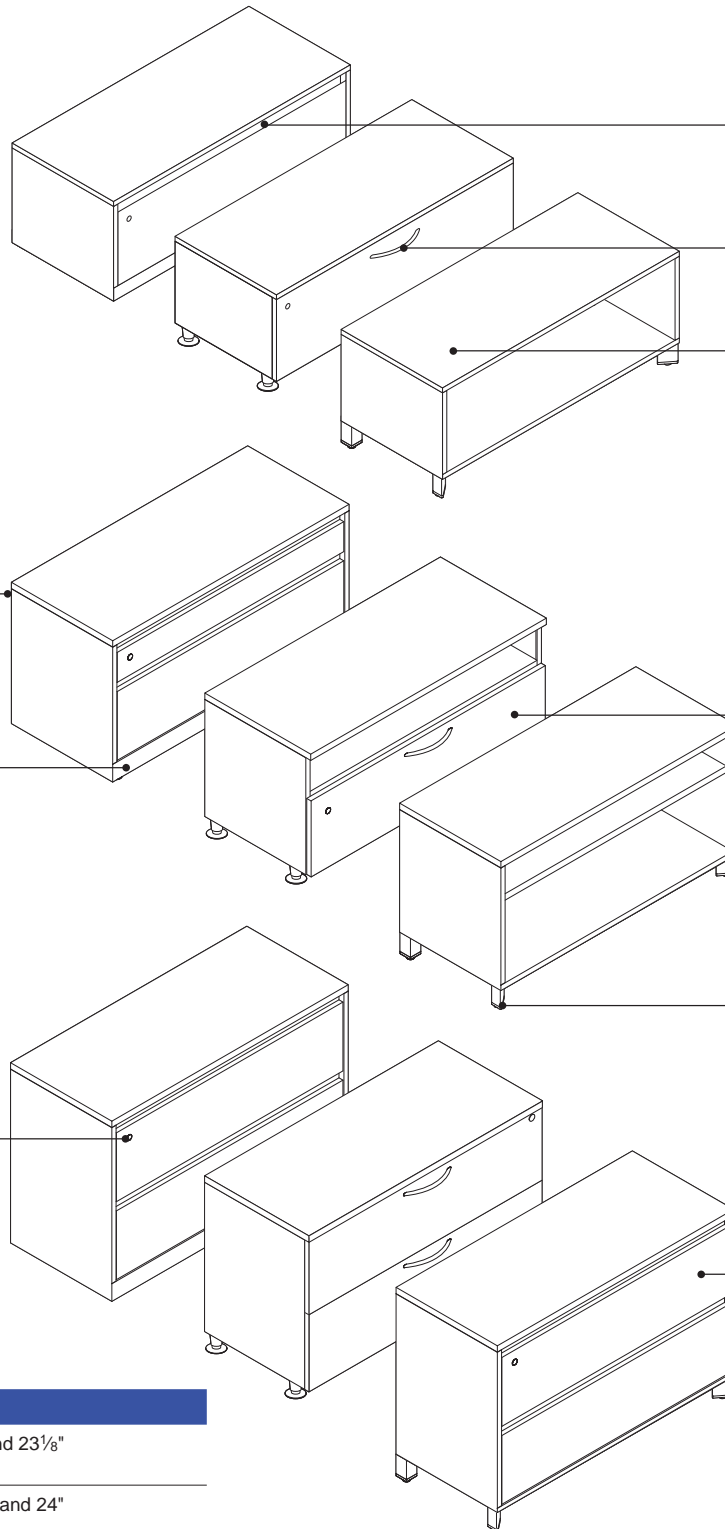

**Pulls on flush-front lateral files** are full width and integral.

**Pulls on proud-front lateral files** are available in a variety of shapes.

**Top** is standard 1"H steel on units with steel fronts and standard 1<sup>3</sup>/<sub>16</sub>"H wood veneer on units with wood fronts. Other top options are available.

**Drawer fronts** are available in steel, laminate, or wood veneer.

**Leveling glides** adjust up to <sup>3</sup>/<sub>4</sub>" for universal 3" base and up to 1" for c:scape glide and FrameOne foot base to install lateral file on uneven floors.

**Drawers** are standard 12"H and open full depth for total access to the contents.

## Actual Dimensions

**Depth with flush steel or open front** 18" and 23<sup>1</sup>/<sub>8</sub>"

**Depth with proud steel, laminate, or wood front** 18<sup>7</sup>/<sub>8</sub>" and 24"

**Width** 30", 36", and 42"

**Height** 16", 22", and 28"

**Product Details**

**Base options**



Universal 3" Base

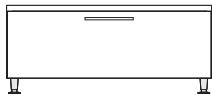

c:scape Glide Base

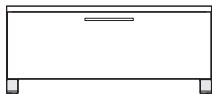

FrameOne Foot Base

Tip: All base options have same overall height.

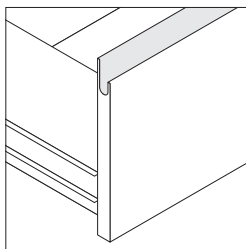

**Flush-front pull** is full width and integral with the drawer. Pull is available on steel drawers only.



Contemporary pull



Handle pull



Jazz pull



Bar pull



c:scape pull

**Proud-front pulls** are available in the following styles—contemporary, handle, jazz, and bar. Each pull is 192 mm and available on steel or wood veneer drawers. c:scape pulls (200 mm) are available on steel drawers only.

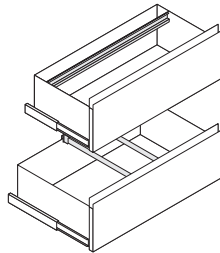

**Drawer interiors** include one hanging folder bar per drawer in each 18"D case and two rails per drawer in each 24"D case. Alternative interiors are available as options.

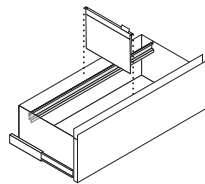

**Hanging folder bar** accommodates side-to-side filing of letter-, A4 international-, and legal-size hanging folders. Additional bars are available and must be specified separately. ▶ See *Storage Specification Guide*.

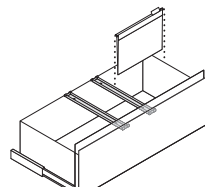

**Rails** accommodate front-to-back filing of letter-, A4 international-, and legal-size hanging folders. Rail packages accommodate two rows of letter-size files in 30"W and 36"W drawers and three rows of letter-size files in 42"W drawers. See *Storage Capacities* for additional details. Additional rails are available and must be specified separately. ▶ For interior dimensions, see *Storage Capacities and Dimensions* in the *Storage Specification Guide*.

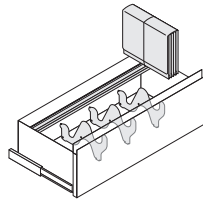

**Dividers** accommodate side-to-side filing of expandable folders and other objects. Divider packages include three dividers per drawer, 12"H file drawers also include one hanging folder bar per drawer. Additional dividers are available and must be specified separately. ▶ See *Storage Specification Guide*.

**Safety interlock system** allows only one drawer to be opened at a time.

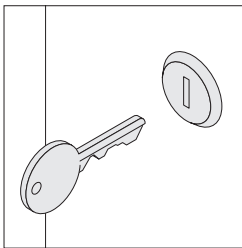

**Locks** are available factory- or field-installed. Factory-installed locks are standard and available keyed random only. Optional field-installed locks are available with consecutive, specific, and random keying options. Master-keyed locks are also available. Field-installed lock cylinders must be specified separately. ▶ *Lock and Keying*, page 375

**Individual drawer locks** are available as an option for an application that would limit access to each drawer. Lateral files include a security shield between drawers to prevent unauthorized access. Individual locking drawers are only available with field-installed locks. Consecutive, specific, and random keying are available. Field-installed lock cylinders must be specified separately. ▶ *Lock and Keying*, page 375

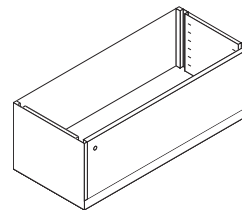

**No-top lateral files** are available for use with cushion top or beneath a common top shared among several lateral files. Hardware is included to attach case to worksurface. No-top option reduces height of file by 1".

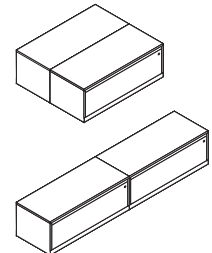

**Ganging hardware** is included to provide alignment by joining adjacent components side-by-side, back-to-back, or both.

**Counterweight packages** are required to ensure product stability and are ordered as an option or separately. Product specification pages indicate the correct counterweight package for each style number and any exceptions where counterweights are not required.

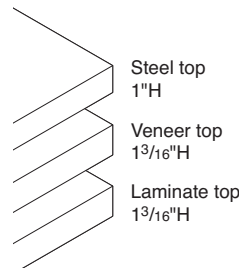

**Laminate and wood veneer tops** with square-edge profiles are available in place of standard 1"H steel tops. Laminate and wood veneer tops are 3/16" taller than steel tops and will add that dimension to the overall height of the lateral file.

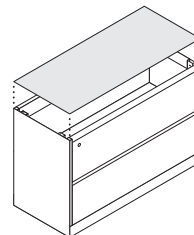

**Security top** is available as an option for installations where the file will be installed beneath a worksurface, but not physically attached. Thin steel top prevents unauthorized access to the contents of the cabinet. Security top is not structural and can be specified on 28"H files only. Security top reduces overall height of file to approximately 27"H.

**Connections**

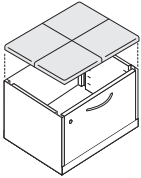

**Cushion top** is ordered separately for use on One-High, 1.5-High, and Two Drawer lateral files without top.

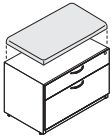

**Basic cushion enhanced** is ordered separately for use on Universal One-High, 1.5-High, and Two Drawer laterals with metal, laminate, or veneer top. Basic cushion enhanced is field-installed and attaches to the existing top with hook and loop fastener.  
*Tip: Basic cushion enhanced is available on Universal lateral files with a top only.*

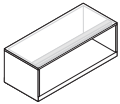

**When applying the basic cushion enhanced on 30"W or 36"W Universal laterals with an open configuration**, a support brace must also be specified.

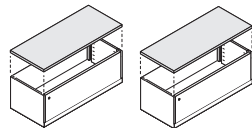

Wood veneer with square edge profile      Laminate with square edge profile

**Field-installed tops** are available in two choices—wood veneer with square edge profile or laminate with square edge profile. Tops can be used on an individual lateral file, or larger tops can be used to connect files to make a credenza.  
▶ See *Storage Specification Guide*.

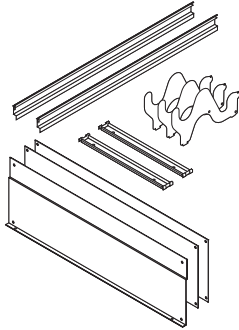

**Field-installed accessories** are available, including drawer accessories and counterweight packages.  
▶ Page 332

**Floor anchor bracket (for TS Series Storage and Universal Storage with 3" base)** secures lateral files, towers, cabinets, or bookcases to the floor for stability or to reduce the risk of hazards during earthquakes in seismic zones. Four bracket packages are required for each cabinet.  
*Note: Local seismic requirements vary. Compliance with local code requirements is the responsibility of the customer or their authorized agent. For a California Office of Statewide Health Planning and Development (OSHPD) approved anchor bracket, contact Steelcase Specials. Tip: Anchor bracket cannot be used with pedestals.*  
▶ Page 333

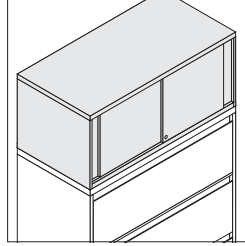

**Overfile cabinets** are separate components that are field installed on top of lateral files, combination cabinets, storage cabinets, and wardrobe cabinets to provide space for additional files, ring binders, or miscellaneous storage.  
▶ See *Storage Specification Guide*.

**Surface Materials**

**Lateral, including steel top, fixed shelf, and integral pulls**

- Paint

**Contemporary, handle, jazz, and bar pulls**

- 0835 Black
- 9201 Polished Chrome
- 9211 Nickel
- 9212 Silver

**scape pull**

- 4140 Arctic White Gloss
- 4144 Black Gloss
- 4799 Platinum Metallic

**Wood veneer top, lift-up door, and drawer fronts**

- Wood veneer—Open pore finishes
- Customiz stain (option)
- Full-fill finish (option) is available on field-installed wood veneer tops only.  
*Tip: Specify file with no top option.*

**Laminate top, lift-up door, and drawer fronts**

- Laminate
- Open Line laminate (option)

**Lock**

- 9201 Polished Chrome
- 9250 Ember Chrome (option)

**Drawer bodies, hanging folder bars, rails, and dividers**

- Black

**Cushion top**

- Fabric
- Leather

**Basic cushion enhanced**

- Fabric

*Tip: For both cushion top and basic cushion enhanced: fabric patterns with a linear design will always be applied from the front to back of the unit or the depth of the unit. Pattern matching will not be done on COM.*

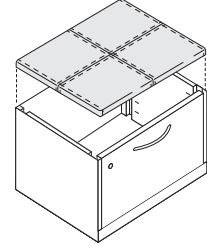

**Cushion top** will be manufactured in a four seam pattern in all standard solid color seating upholstery, leather, vinyls, COM leathers, and COM vinyls. These upholsteries are:

- Brisa
- Buzz2
- Cogent: Connect
- Elmosoft Leather
- Foundation
- Gaja
- Leather
- Stand In
- Select Surfaces leather
- Vinyl

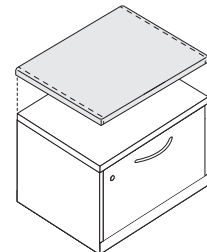

**Cushion top** will be manufactured in a two seam pattern for all approved standard patterned seating upholstery, leather, vinyl, COM leathers, and COM vinyls. All approved standard textured upholsteries will also be manufactured in a two seam pattern including leather, vinyl, COM leathers, and COM vinyls.

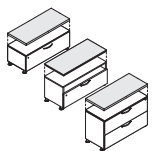

**Basic cushion enhanced** will be manufactured in a two seam pattern for all approved standard seating upholstery and Customer's Own Materials (COMs).

*Note: Leathers and vinyls are not approved for basic cushion enhanced.*

### Application Topics

#### Storage Capacities and Dimensions

▶ See *Storage Specification Guide*.

#### Counterweight Requirements for Storage Products

▶ Page 111.

### Shipping

**Lateral files** are normally shipped in heavy-duty, recyclable stretch wrap to reduce the amount of corrugated board needed.

**Counterweight packages** ship separately from case and must be field-installed.

# Universal Towers

**Towers** provide storage of a variety of work and personal items for an individual, including paper, binders, books, and coats.

► Specifying, page 318

**Finished back** is standard.

**Interior of tower** is available in a variety of configurations combining coat storage, fixed and adjustable shelves, and file drawers.

**Pull on flush-front tower** is integral and full height on doors and full width on drawers.

**Locks** are standard on door and drawers. Locks are standard factory-installed, keyed random. Door and drawer locks are keyed alike.

► *Lock and Keying*, page 375

**Three base options are available:** the universal 3" base, FrameOne foot, and c:scape glide. All three bases have the same overall height. All other universal towers are available with the universal 3" base only.

**Drawers** open their full depth for total access to the contents.

**Leveling glides** adjust up to  $\frac{3}{4}$ " for universal 3" base and up to 1" for c:scape glide and FrameOne foot base to install tower on uneven floors.

**Top** is standard 1"H steel. Other top options are available.

**Door** is available in steel, laminate, or wood veneer. Hinges are European-style and allow doors to open to 110° for full access to the interior. Door is available hinged on left or right.

**Locker space** is 9" wide and standard with a coat rod.

**Pull on proud-front tower** is available in a variety of shapes.

**Drawer fronts** are available in steel, laminate, or wood veneer.

## Actual Dimensions

<b>Depth with flush steel front</b>	18", 23 $\frac{1}{8}$ ", and 29 $\frac{1}{8}$ "
<b>Depth with proud steel, laminate, or wood front</b>	18 $\frac{7}{8}$ ", 24", and 30"
<b>Width</b>	24"
<b>Height</b>	47 $\frac{1}{2}$ ", 52", and 65 $\frac{1}{2}$ "

**Product Details**

**Base options**



**Universal 3" Base**



**c:scape Glide Base**



**FrameOne Foot Base**

**All base options** have same overall height. FrameOne foot base and c:scape glide base are only available on 18"D and 24"D open side towers.



**Interior of tower** combines coat storage, box and file drawers, fixed and adjustable shelves.

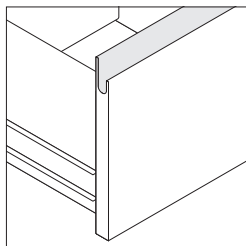

**Flush-front pull** is integral and full height on the door and full width on the drawers. Pull is available on steel doors and drawers only.

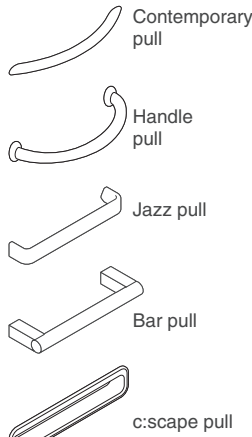

**Proud-front pulls** are available in the following styles—contemporary, handle, jazz, and bar. Door pull is 192 mm and drawer pulls are 128 mm. Proud-front pulls are available on steel, laminate, or wood veneer doors and drawers. c:scape pulls (200 mm) are available on steel only.

**Adjustable shelves on 52"H and 65½"H open side towers** are recessed from the front and side of the tower. Shelves adjust in 2½" vertical increments. Opening on 47½"H tower is 13½"H and does not come with an adjustable shelf.

**Post on open side towers** supports adjustable shelves and is painted to match the case.

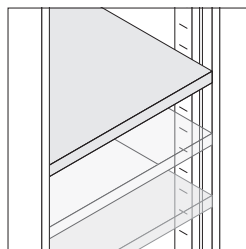

**Adjustable shelves in dual door towers** can be positioned in the interior of the tower in ¾" vertical increments using a reversible bracket. The first shelf above a file drawer is a fixed shelf.

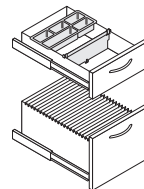

**Drawer accessories** include one divider and one pencil tray in each box drawer. File drawers can accommodate front-to-back filing of letter-size hanging folders without the use of additional accessories.

**Safety interlock system** allows only one drawer to be opened at a time.

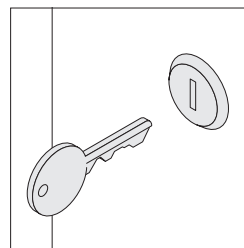

**Locks** are available factory- or field-installed. Factory-installed locks are standard and available keyed random only. Door and drawer locks are keyed alike. Optional field-installed locks are available with consecutive, specific, and random keying options. Master-keyed locks are also available. Field-installed lock cylinders must be specified separately.

► *Lock and Keying*, page 375

**Drawer lock in open side tower** is located in the top file drawer.

**Drawer lock in dual door tower** is located approximately 36" from the floor.

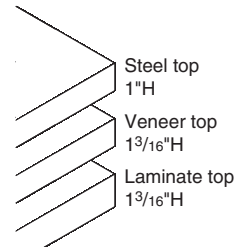

**Laminate and wood veneer tops** with square-edge profiles are available in place of standard 1"H steel tops. Laminate and wood veneer tops are ¾" taller than steel tops and will add that dimension to the overall height of the tower.

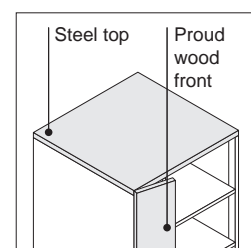

**Top** will default to steel on towers with proud wood fronts since the door overlaps and partially conceals the top. Wood top is available as an option.

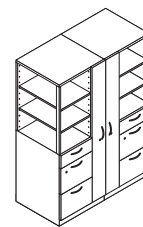

**Ganging hardware** is included to provide alignment by joining adjacent components side-by-side, back-to-back, or both.

**Counterweight packages** are required to ensure product stability and are ordered as an option or separately. Product specification pages indicate the correct counterweight package for each style number and any exceptions where counterweights are not required.

**Connections**

**Worksurface to tower alignment.** Proud front towers align with 23½"D, 24"D, 29½"D, and 30"D worksurfaces. Flush front towers extend ⅞" beyond 24"D and 30"D worksurfaces, and ⅙" beyond 23½"D and 29½"D worksurfaces.

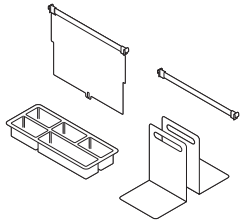

**Field-installed accessories** are available, including drawer accessories and shelf bookends.  
▶ Page 332

**Floor anchor bracket (for TS Series Storage and Universal Storage with 3" base)** secures lateral files, towers, cabinets, or bookcases to the floor for stability or to reduce the risk of hazards during earthquakes in seismic zones. Four bracket packages are required for each cabinet.  
**Note: Local seismic requirements vary.** Compliance with local code requirements is the responsibility of the customer or their authorized agent. For a California Office of Statewide Health Planning and Development (OSHPD) approved anchor bracket, contact Steelcase Specials.  
*Tip: Anchor bracket cannot be used with pedestals.*  
▶ Page 333

**Surface Materials**

**Tower, including steel top, hinged door, integral pulls, drawer fronts, and adjustable shelves**

- Paint

**Post**

- Paint to match tower (default)

**Contemporary, handle, jazz, and bar pulls**

- 0835 Black
- 9201 Polished Chrome
- 9211 Nickel
- 9212 Silver

**c:scape pull**

- 4140 Arctic White Gloss
- 4144 Black Gloss
- 4799 Platinum Metallic

**Wood veneer top, hinged doors, and drawer fronts**

- Wood veneer—  
Open pore finishes
- Customiz stain (option)

**Laminate top, hinged doors, and drawer fronts**

- Laminate
- Open Line laminate (option)

**Lock**

- 9201 Polished Chrome
- 9250 Ember Chrome (option)

**Drawer bodies, pencil tray, and box drawer divider**

- Black

**Coat rod**

- Black with black supports

**Application Topics**

**Storage Capacities and Dimensions**

▶ See *Storage Specification Guide*.

**Counterweight Requirements for Storage Products**

▶ Page 111.

**Shipping**

**Towers** are normally shipped in heavy-duty, recyclable stretch wrap to reduce the amount of corrugated board needed.

**Counterweight packages** ship separately from case and must be field installed.



# Universal Lateral Files

**Lateral files** are ideal for high-density paper storage.  
 ▶ Specifying, page 328

**Finished back** is standard.

**Lock** is standard on lateral files and secures all drawers and lift-up door. On 52"H and 65½"H files, lock is located at top left corner of drawer that is third from the bottom. On 28"H and 40"H files, lock is located at top left corner of top drawer. Locks are standard factory-installed, keyed random.  
 ▶ Lock and Keying, page 375

**Base** is 3"H and is integral to the case.

**Leveling glides** adjust up to ¾" for universal 3" base and up to 1" for c:scape glide and FrameOne foot base to install lateral file on uneven floors.

**Drawer and lift-up door fronts** are available in steel, laminate, or wood veneer.

**Pulls on proud-front lateral files** are available in a variety of shapes. Pulls are located at the top of a drawer and at the bottom of a lift-up door.

**Top** is standard 1"H steel on units with steel fronts and standard 1⅜"H wood veneer on units with wood fronts. Other top options are available.

## Product Details

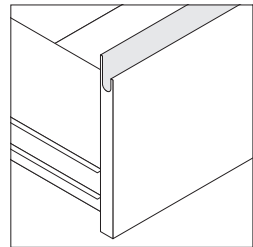

**Flush-front pull** is full width and integral with the drawer. Pull is available on steel drawers only.

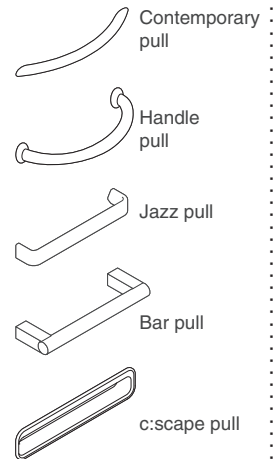

**Proud-front pulls** are available in the following styles—contemporary, handle, jazz, and bar. Each pull is 192 mm and available on steel or wood veneer doors and drawers. c:scape pulls (200 mm) are available on steel only.

**Drawers** open their full depth for total access to the contents are standard 12"H.

**Label holders** are included with each drawer. Label holder fits inside the integral pull or can be affixed to the front of the drawer or door. Perforated labels are included and can be created using the template available on [www.steelcase.com/label](http://www.steelcase.com/label).

**Pull on flush-front lateral file** is full width and integral.

## Actual Dimensions

<b>Depth with flush steel front</b>	18" and 23⅛"
<b>Depth with proud steel, laminate, or wood front</b>	18⅞" and 24"
<b>Width</b>	30", 36", and 42"
<b>Height</b>	28", 40", 52", and 65½"

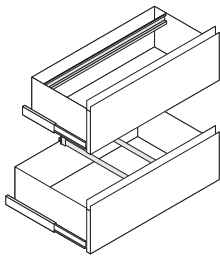

**Drawer interiors** include one hanging folder bar per drawer in each 18"D case and two rails per drawer in each 24"D case. Alternative interiors are available as options. *Tip: Your specification for optional drawer interiors will apply to all the drawers within a single lateral file.*

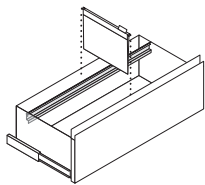

**Hanging folder bar** accommodates side-to-side filing of letter-, A4 international-, and legal-size hanging folders. Additional bars are available and must be specified separately. *► See Storage Specification Guide.*

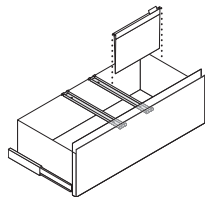

**Rails** accommodate front-to-back filing of letter-, A4 international-, and legal-size hanging folders. Rail packages accommodate two rows of letter-size files in 30"W and 36"W drawers and three rows of letter-size files in 42"W drawers. See *Storage Capacities* for additional details. Additional rails are available and must be specified separately. *► For interior dimensions, see Storage Capacities and Dimensions in the Storage Specification Guide.*

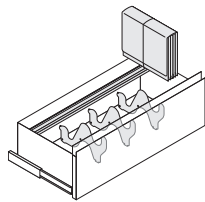

**Dividers** accommodate side-to-side filing of expandable folders and other objects. Divider packages include three dividers and one hanging folder bar per drawer. Additional dividers are available and must be specified separately. *► See Storage Specification Guide.*

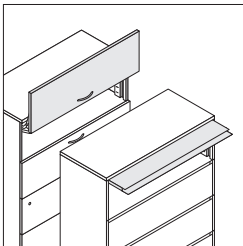

**Lift-up door with fixed shelf** is standard in the top position of 65½"H cases. Door is 13½"H to accommodate standard-height binders. Door on lateral files with flush-front recesses inside the case; door on proud-front case lifts up above the case.

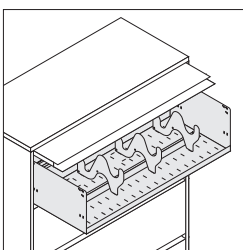

**Lift-up door on flush-front cases** is available with an optional roll-out shelf in place of the standard fixed shelf. Roll-out shelf includes three dividers and one hanging file folder bar to function as a backstop.

**Safety interlock system** allows only one drawer or roll-out shelf to be opened at a time.

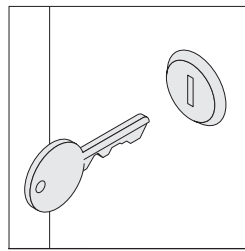

**Locks** are available factory- or field-installed. Factory-installed locks are standard and available keyed random only. Optional field-installed locks are available with consecutive, specific, and random keying options. Master-keyed locks are also available. Field-installed lock cylinders must be specified separately. *► Lock and Keying, page 375*

**Individual drawer locks** are available as an option for applications where you want to limit access to each drawer. Lateral files include a security shield above each drawer to prevent unauthorized access. In 65½"H cases, the lock in the drawer below controls the lift-up door in the top position. Individual locking drawers are only available with field-installed locks. Consecutive, specific, and random keying options are available. Field-installed lock cylinders must be specified separately. *► Lock and Keying, page 375*

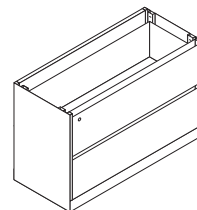

**No-top lateral files** are available for installations where cases will be installed under a worksurface or beneath a common top shared among several lateral files. Hardware is included to attach case to worksurface. No-top option reduces height of file by 1".

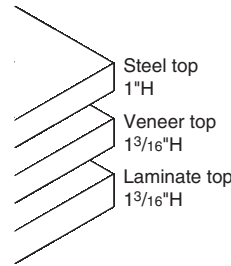

**Laminate and wood veneer tops** with square-edge profiles are available in place of standard 1"H steel tops. Laminate and wood veneer tops are 3/16" taller than steel tops and will add that dimension to the overall height of the lateral file.

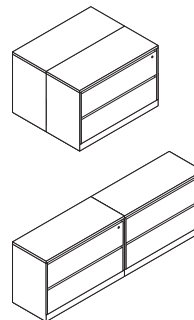

**Ganging hardware** is included to provide alignment by joining adjacent components side-by-side, back-to-back, or both.

**Counterweight packages** are required to ensure product stability and are ordered as an option or separately. Product specification pages indicate the correct counterweight package for each style number and any exceptions where counterweights are not required.

**Connections**

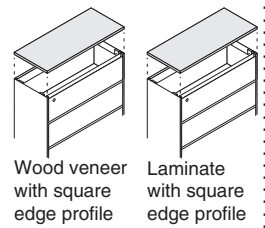

**Field-installed tops** are available in two choices—wood veneer with square edge profile or laminate with square edge profile. Tops can be used on an individual lateral file, or larger tops can be used to connect files to make a credenza. *► See Storage Specification Guide.*

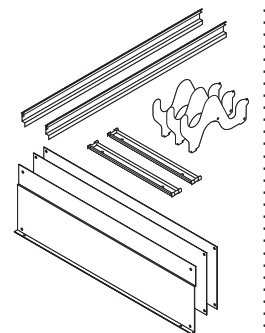

**Field-installed accessories** are available, including drawer accessories and counterweight packages. *► Page 332*

**Floor anchor bracket (for TS Series Storage and Universal Storage with 3" base)**

secures lateral files, towers, cabinets, or bookcases to the floor for stability or to reduce the risk of hazards during earthquakes in seismic zones.

Four bracket packages are required for each cabinet.

**Note: Local seismic requirements vary.** Compliance with local code requirements is the responsibility of the customer or their authorized agent.

For a California Office of Statewide Health Planning and Development (OSHPD) approved anchor bracket, contact Steelcase Specials.

*Tip: Anchor bracket cannot be used with pedestals.*

▶ Page 333

**Surface Materials**

**Lateral file, including steel top, drawer fronts, lift-up door, fixed shelf, and integral pulls**

- Paint

**Contemporary, handle, jazz, and bar pulls**

- 0835 Black
- 9201 Polished Chrome
- 9211 Nickel
- 9212 Silver

**c:scape pull**

- 4140 Arctic White Gloss
- 4144 Black Gloss
- 4799 Platinum Metallic

**Wood veneer top, lift-up door, and drawer fronts**

- Wood veneer—
    - Open pore finishes
  - Customiz stain (option)
  - Full-fill finish (option) is available on field-installed wood veneer tops only.
- Tip: Specify file with no top option.*

**Laminate top, lift-up door, and drawer fronts**

- Laminate
- Open Line laminate (option)

**Lock**

- 9201 Polished Chrome
- 9250 Ember Chrome (option)

**Drawer bodies, roll-out shelves, hanging folder bars, rails, and dividers**

- Black

**Application Topics**

**Storage Capacities and Dimensions**

▶ See *Storage Specification Guide*.

**Counterweight Requirements for Storage Products**

▶ Page 111.

**Shipping**

**Lateral files** are normally shipped in heavy-duty, recyclable stretch wrap to reduce the amount of corrugated board needed.

**Counterweight packages** ship separately from case and must be field-installed.

---

# Specifying Kick Solutions

<b>Panels</b>	<b>175</b>
<b>Wiring and Cabling</b>	<b>195</b>
<b>TS Series Worksurfaces</b>	<b>201</b>
<b>Universal Systems Worksurfaces</b>	<b>219</b>
<b>TS Series Storage</b>	<b>271</b>
<b>Universal Steel Storage Products</b>	<b>287</b>



---

# Specifying Panels

<b>Monolithic Panels</b>	<b>176</b>
<b>42"H and 48"H Segmented Panels</b>	<b>178</b>
<b>54"H Segmented Panels</b>	<b>180</b>
<b>66"H Segmented Panels</b>	<b>182</b>
<b>Panel Stackers</b>	<b>184</b>
<b>Panel Trim</b>	<b>186</b>
<b>Panel Connectors</b>	<b>191</b>
<b>Sliding Panel Doors</b>	<b>193</b>

# Monolithic Panels

Tackable Acoustical and Glass

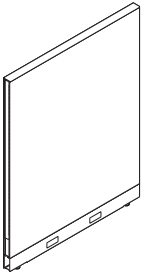

*Tip: To price a panel with two fabric surface materials in different price groups, add the two fabric price group option prices together and divide by 2; then add the result to the panel base price.*

*Tip: Factory-included powerway for field installation option replaces need to order separate powerways.*

*Tip: Field-installed powerways can be ordered through Kick Service Parts.*

*Tip: Remember to order end-of-run trim and vertical corner trim packages.*

*Tip: Panel-mounted slatwall will not hang on a 42"H panel with worksurface. There is not enough space above the worksurface and top of panel for the bracket to engage into panel slots.*

Standard Includes	Required to Specify
<ul style="list-style-type: none"> <li>▶ Need help? Product details, page 10</li> <li>Tackable acoustical panel with two fabric surfaces, if selected: Kick standard fabric price group A</li> <li>Glass insert, if glass panel selected: 6500 Clear</li> <li>Border, if glass panel selected: paint price group 1</li> <li>Base covers with receptacle knockouts: paint price group 1</li> <li>Top cap (low height): paint price group 1</li> <li>Top cap aligner: black plastic</li> <li>Universal connector package</li> <li>Frame: 0835 Black only</li> </ul>	<ol style="list-style-type: none"> <li>Style number</li> <li>Fabric color number for surface 1 of tackable acoustical panel, if selected</li> <li>Fabric color number for surface 2 of tackable acoustical panel, if selected</li> <li>Paint color number for top cap, base covers, and border</li> <li>Options, if selected (see below)                     <ul style="list-style-type: none"> <li>▶ See <i>Surface Materials</i>, page 360.</li> </ul> </li> </ol>

Options	U.S. Price	Required to Specify
<b>Surface Materials</b>	<b>Top cap, base covers, and border on glass panels</b> <ul style="list-style-type: none"> <li>Paint price group 1 No cost</li> <li>Paint price group 2 +\$ 16</li> <li>Paint price group 3 +\$ 34</li> </ul>	Specify paint color number. Specify paint color number. Specify paint color number.
	<b>Fabric surface on tackable acoustical panels</b> <ul style="list-style-type: none"> <li>Kick standard fabric price group A No cost</li> <li>Fabric price group 1 +\$ 10</li> <li>Fabric price group 2 +\$ 64</li> <li>Fabric price group 3 +\$ 96</li> <li>Fabric price group 4 +\$240</li> <li>Fabric price group 5 +\$348</li> <li>Fabric price group COM +\$122</li> </ul>	Specify fabric color number. Specify fabric color number. Specify fabric color number. Specify fabric color number. Specify fabric color number. Specify fabric color number. ▶ See <i>Understanding Customer's Own Material (COM)</i> , page 364.
<b>Top Cap</b>	<ul style="list-style-type: none"> <li>High top cap with knockouts to accommodate cable routing (increases panel height by 1<sup>3</sup>/<sub>4</sub>") +\$ 47</li> </ul>	Specify with <i>high top cap</i> .
<b>Electrical</b>	<b>Factory-installed powerway at base</b> <ul style="list-style-type: none"> <li>3-circuit powerway with shared neutral +\$208</li> <li>3-circuit powerway with separate neutrals +\$258</li> <li>4-circuit (3+D) powerway +\$244</li> <li>4-circuit (3I+1) powerway +\$306</li> <li>4-circuit (2+2) powerway +\$306</li> </ul>	Specify with <i>3-circuit power; shared neutrals</i> . Specify with <i>3-circuit power; separate neutrals</i> . Specify with <i>4-circuit power; 3+D wiring</i> . Specify with <i>4-circuit power; 3I+1 wiring</i> . Specify with <i>4-circuit power; 2+2 wiring</i> .
	<b>Factory-included powerway for field installation for use in New York City</b> <ul style="list-style-type: none"> <li>3-circuit powerway with shared neutral +\$208</li> <li>3-circuit powerway with separate neutrals +\$258</li> <li>4-circuit (3+D) powerway +\$244</li> <li>4-circuit (3I+1) powerway +\$306</li> <li>4-circuit (2+2) powerway +\$306</li> </ul>	Specify with <i>3-circuit power; shared neutrals; not installed</i> . Specify with <i>3-circuit power; separate neutrals; not installed</i> . Specify with <i>4-circuit power; 3+D wiring; not installed</i> . Specify with <i>4-circuit power; 3I+1 wiring; not installed</i> . Specify with <i>4-circuit power; 2+2 wiring; not installed</i> .
<b>Related Products</b>	<ul style="list-style-type: none"> <li>Panel trim</li> <li>Panel connectors</li> <li>Panel wiring and cabling</li> <li>Worksurface-height power and communication access</li> </ul>	<ul style="list-style-type: none"> <li>▶ Page 186</li> <li>▶ Page 191</li> <li>▶ Page 196</li> <li>▶ Page 200</li> </ul>



## For Canadian Pricing

Multiply U.S. Price by the Canadian price factor.

▶ See page 1 for details.

**Specification Information**

**Tackable Acoustical Panels**

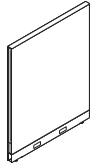

**Glass Panels**



Width	Style Number	U.S. Base Price	Style Number	U.S. Base Price
-------	--------------	-----------------	--------------	-----------------

**42"H**

24"	<b>TSAPF4224</b>	\$ 585	<b>TSAPG4224</b>	\$ 990
30"	<b>TSAPF4230</b>	\$ 608	<b>TSAPG4230</b>	\$1028
36"	<b>TSAPF4236</b>	\$ 668	<b>TSAPG4236</b>	\$1126
42"	<b>TSAPF4242</b>	\$ 740	<b>TSAPG4242</b>	\$1259
48"	<b>TSAPF4248</b>	\$ 789	<b>TSAPG4248</b>	\$1330
60"	<b>TSAPF4260</b>	\$ 906		

**48"H**

24"	<b>TSAPF4824</b>	\$ 608	<b>TSAPG4824</b>	\$1029
30"	<b>TSAPF4830</b>	\$ 667	<b>TSAPG4830</b>	\$1124
36"	<b>TSAPF4836</b>	\$ 714	<b>TSAPG4836</b>	\$1206
42"	<b>TSAPF4842</b>	\$ 812	<b>TSAPG4842</b>	\$1379
48"	<b>TSAPF4848</b>	\$ 871	<b>TSAPG4848</b>	\$1468
60"	<b>TSAPF4860</b>	\$ 961		

**54"H**

24"	<b>TSAPF5424</b>	\$ 613	<b>TSAPG5424</b>	\$1038
30"	<b>TSAPF5430</b>	\$ 682	<b>TSAPG5430</b>	\$1152
36"	<b>TSAPF5436</b>	\$ 726	<b>TSAPG5436</b>	\$1223
42"	<b>TSAPF5442</b>	\$ 831	<b>TSAPG5442</b>	\$1408
48"	<b>TSAPF5448</b>	\$ 887	<b>TSAPG5448</b>	\$1503
60"	<b>TSAPF5460</b>	\$ 968		

**66"H**

24"	<b>TSAPF6624</b>	\$ 625	<b>TSAPG6624</b>	\$1065
30"	<b>TSAPF6630</b>	\$ 714	<b>TSAPG6630</b>	\$1206
36"	<b>TSAPF6636</b>	\$ 760	<b>TSAPG6636</b>	\$1283
42"	<b>TSAPF6642</b>	\$ 858	<b>TSAPG6642</b>	\$1456
48"	<b>TSAPF6648</b>	\$ 946	<b>TSAPG6648</b>	\$1603
60"	<b>TSAPF6660</b>	\$1074		

# 42"H and 48"H Segmented Panels

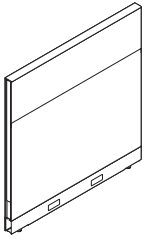

	Standard Includes	Required to Specify
▶ Need help? Product details, page 12	<ul style="list-style-type: none"> <li>Panel with segmented, fabric surfaces: Kick standard fabric price group A</li> <li>Base covers with receptacle knockouts: paint price group 1</li> <li>Top cap (low height): paint price group 1</li> <li>Top cap aligner: black plastic</li> <li>Universal connector package</li> <li>Frame: 0835 Black only</li> </ul>	<ol style="list-style-type: none"> <li>Style number</li> <li>Fabric color number for base skin, surface 1</li> <li>Fabric color number for accent skin, surface 1</li> <li>Fabric color number for base skin, surface 2</li> <li>Fabric color number for accent skin, surface 2</li> <li>Paint color number for top cap and base covers</li> <li>Options, if selected (see below)</li> </ol> <p>▶ See <i>Surface Materials</i>, page 360.</p>

	Options	U.S. Price	Required to Specify
<b>Surface Materials</b>	<b>Top cap and base covers</b>		
	<ul style="list-style-type: none"> <li>Paint price group 1</li> <li>Paint price group 2</li> <li>Paint price group 3</li> </ul>	No cost +\$ 16 +\$ 34	Specify paint color number. Specify paint color number. Specify paint color number.
	<b>Base skin surface</b>		
	<ul style="list-style-type: none"> <li>Kick standard fabric price group A</li> <li>Fabric price group 1</li> <li>Fabric price group 2</li> <li>Fabric price group 3</li> <li>Fabric price group 4</li> <li>Fabric price group 5</li> <li>Fabric price group COM</li> </ul>	No cost +\$ 10 +\$ 64 +\$ 96 +\$240 +\$348 +\$122	Specify fabric color number. Specify fabric color number. Specify fabric color number. Specify fabric color number. Specify fabric color number. Specify fabric color number. Specify fabric color number. ▶ See <i>Understanding Customer's Own Material (COM)</i> , page 364.
	<b>Accent skin surface</b>		
	<ul style="list-style-type: none"> <li>Kick standard fabric price group A</li> <li>Fabric price group 1</li> <li>Fabric price group 2</li> <li>Fabric price group 3</li> <li>Fabric price group 4</li> <li>Fabric price group COM</li> </ul>	No cost +\$ 3 +\$ 11 +\$ 21 +\$ 61 +\$ 33	Specify fabric color number. Specify fabric color number. Specify fabric color number. Specify fabric color number. Specify fabric color number. Specify fabric color number. ▶ See <i>Understanding Customer's Own Material (COM)</i> , page 364.
<b>Top Cap</b>	<ul style="list-style-type: none"> <li>High top cap with knockouts to accommodate cable routing (increases panel height by 1<sup>3</sup>/<sub>4</sub>")</li> </ul>	+\$ 47	Specify with <i>high top cap</i> .
<b>Electrical</b>	<b>Factory-installed powerway at base</b>		
	<ul style="list-style-type: none"> <li>3-circuit powerway with shared neutrals</li> <li>3-circuit powerway with separate neutrals</li> <li>4-circuit (3+D) powerway</li> <li>4-circuit (3I+1) powerway</li> <li>4-circuit (2+2) powerway</li> </ul>	+\$208 +\$258 +\$244 +\$306 +\$306	Specify with <i>3-circuit power; shared neutrals</i> . Specify with <i>3-circuit power; separate neutrals</i> . Specify with <i>4-circuit power; 3+D wiring</i> . Specify with <i>4-circuit power; 3I+1 wiring</i> . Specify with <i>4-circuit power; 2+2 wiring</i> .

▶ Options, continued on next page

*Tip: To price a panel with two base skin surfaces in different fabric price groups, add the two fabric price group option prices together and divide by two; then add the result to the panel base price.*



**For Canadian Pricing**  
 Multiply U.S. Price by the Canadian price factor.  
 ▶ See page 1 for details.

► Options, continued from previous page

Tip: Factory-included powerway for field installation option replaces need to order separate powerways.

Tip: Field-installed powerways can be ordered through Kick Service Parts.

Tip: Remember to order end-of-run trim and vertical corner trim packages.

Tip: Panel-mounted slatwall will not hang on a 42"H panel with worksurface. There is not enough space above the worksurface and top of panel for the bracket to engage into panel slots.

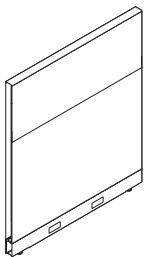
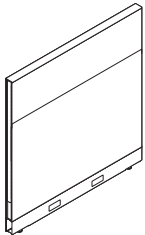

Options	U.S. Price	Required to Specify
<b>Electrical, continued</b>	<b>Factory-included powerway for field installation for use in New York City</b>	
• 3-circuit powerway with shared neutral	+\$208	Specify with 3-circuit power; shared neutrals; not installed.
• 3-circuit powerway with separate neutrals	+\$258	Specify with 3-circuit power; separate neutrals; not installed.
• 4-circuit (3+D) powerway	+\$244	Specify with 4-circuit power; 3+D wiring; not installed.
• 4-circuit (3I+1) powerway	+\$306	Specify with 4-circuit power; 3I+1 wiring; not installed.
• 4-circuit (2+2) powerway	+\$306	Specify with 4-circuit power; 2+2 wiring; not installed.
<b>Segmentation</b>	• Option 1	+\$126
► See below.		Specify with option 1.

Related Products		
• Panel trim		► Page 186
• Panel connectors		► Page 191
• Panel wiring and cabling		► Page 196
• Worksurface-height power and communication access		► Page 200

Specification Information		
Width	Style Number	U.S. Base Price

42"H		
24"	<b>TSAPL4224</b>	\$ 766
30"	<b>TSAPL4230</b>	\$ 792
36"	<b>TSAPL4236</b>	\$ 847
42"	<b>TSAPL4242</b>	\$ 924
48"	<b>TSAPL4248</b>	\$ 968
60"	<b>TSAPL4260</b>	\$1083
•	•	•

48"H		
24"	<b>TSAPL4824</b>	\$ 795
30"	<b>TSAPL4830</b>	\$ 847
36"	<b>TSAPL4836</b>	\$ 892
42"	<b>TSAPL4842</b>	\$ 997
48"	<b>TSAPL4848</b>	\$1051
60"	<b>TSAPL4860</b>	\$1142
•	•	•

**Segmentation**

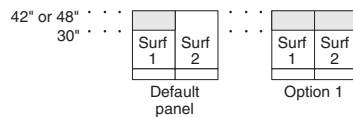

 **For Canadian Pricing**  
Multiply U.S. Price by the Canadian price factor.  
► See page 1 for details.

Tip: Shaded area represents accent skin. This skin can be specified in different fabric from base skin.

# 54"H Segmented Panels

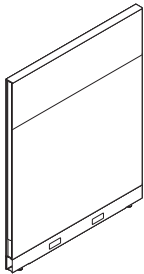

Standard Includes	Required to Specify
<ul style="list-style-type: none"> <li>▶ Need help? Product details, page 12</li> <li>• Panel with segmented, fabric surfaces: Kick standard fabric price group A</li> <li>• Base covers with receptacle knockouts: paint price group 1</li> <li>• Top cap (low height): paint price group 1</li> <li>• Top cap aligner: black plastic</li> <li>• Universal connector package</li> <li>• Frame: 0835 Black only</li> </ul>	<ol style="list-style-type: none"> <li>1 Style number</li> <li>2 Fabric color number for base skin, surface 1</li> <li>3 Fabric color number for accent skin, surface 1</li> <li>4 Fabric color number for base skin, surface 2</li> <li>5 Fabric color number for accent skin, surface 2</li> <li>6 Paint color number for top cap and base covers</li> <li>7 Options, if selected (see below)</li> </ol> <p>▶ See <i>Surface Materials</i>, page 360.</p>

Surface Materials	Options	U.S. Price	Required to Specify	
	<b>Top cap and base covers</b> <ul style="list-style-type: none"> <li>• Paint price group 1</li> <li>• Paint price group 2</li> <li>• Paint price group 3</li> </ul>	No cost +\$ 16 +\$ 34	Specify paint color number. Specify paint color number. Specify paint color number.	
	<b>Base skin surface</b> <ul style="list-style-type: none"> <li>• Kick standard fabric price group A</li> <li>• Fabric price group 1</li> <li>• Fabric price group 2</li> <li>• Fabric price group 3</li> <li>• Fabric price group 4</li> <li>• Fabric price group 5</li> <li>• Fabric price group COM</li> </ul>	No cost +\$ 10 +\$ 64 +\$ 96 +\$240 +\$348 +\$122	Specify fabric color number. Specify fabric color number. Specify fabric color number. Specify fabric color number. Specify fabric color number. Specify fabric color number. Specify fabric color number. ▶ See <i>Understanding Customer's Own Material (COM)</i> , page 364.	
	<b>Accent skin surface</b> <ul style="list-style-type: none"> <li>• Kick standard fabric price group A</li> <li>• Fabric price group 1</li> <li>• Fabric price group 2</li> <li>• Fabric price group 3</li> <li>• Fabric price group 4</li> <li>• Fabric price group COM</li> </ul>	No cost +\$ 3 +\$ 11 +\$ 21 +\$ 61 +\$ 33	Specify fabric color number. Specify fabric color number. Specify fabric color number. Specify fabric color number. Specify fabric color number. Specify fabric color number. ▶ See <i>Understanding Customer's Own Material (COM)</i> , page 364.	
	<b>Top Cap</b> <ul style="list-style-type: none"> <li>• High top cap with knockouts to accommodate cable routing (increases panel height by 1<sup>3</sup>/<sub>4</sub>"</li> </ul>	+\$ 47	Specify <i>with high top cap</i> .	
	<b>Electrical</b>	<b>Factory-installed powerway at base</b> <ul style="list-style-type: none"> <li>• 3-circuit powerway with shared neutral</li> <li>• 3-circuit powerway with separate neutrals</li> <li>• 4-circuit (3+D) powerway</li> <li>• 4-circuit (3I+1) powerway</li> <li>• 4-circuit (2+2) powerway</li> </ul>	+\$208 +\$258 +\$244 +\$306 +\$306  <b>Factory-included powerway for field installation for use in New York City</b> <ul style="list-style-type: none"> <li>• 3-circuit powerway with shared neutral</li> <li>• 3-circuit powerway with separate neutrals</li> <li>• 4-circuit (3+D) powerway</li> <li>• 4-circuit (3I+1) powerway</li> <li>• 4-circuit (2+2) powerway</li> </ul>	Specify <i>with 3-circuit power; shared neutrals</i> . Specify <i>with 3-circuit power; separate neutrals</i> . Specify <i>with 4-circuit power; 3+D wiring</i> . Specify <i>with 4-circuit power; 3I+1 wiring</i> . Specify <i>with 4-circuit power; 2+2 wiring</i> .  Specify <i>with 3-circuit power; shared neutrals; not installed</i> . Specify <i>with 3-circuit power; separate neutrals; not installed</i> . Specify <i>with 4-circuit power; 3+D wiring; not installed</i> . Specify <i>with 4-circuit power; 3I+1 wiring; not installed</i> . Specify <i>with 4-circuit power; 2+2 wiring; not installed</i> .

Tip: To price a panel with two base skin surfaces in different fabric price groups, add the two fabric price group option prices together and divide by two; then add the result to the panel base price.

Tip: Factory-included powerway for field installation option replaces need to order separate powerways.

Tip: Field-installed powerways can be ordered through Kick Service Parts.

▶ Options, continued on next page

► Options, continued from previous page

Options	U.S. Price	Required to Specify
<b>Segmentation</b> ► See below.	<ul style="list-style-type: none"> <li>Option 1 +\$126</li> <li>Option 2 +\$126</li> <li>Option 3 +\$382</li> <li>Option 4 +\$ 28</li> <li>Option 5 +\$173</li> </ul>	Specify with option 1. Specify with option 2. Specify with option 3. Specify with option 4. Specify with option 5.
<b>Related Products</b>	<ul style="list-style-type: none"> <li>Panel trim</li> <li>Panel connectors</li> <li>Panel wiring and cabling</li> <li>Worksurface-height power and communication access</li> </ul>	<ul style="list-style-type: none"> <li>► Page 186</li> <li>► Page 191</li> <li>► Page 196</li> <li>► Page 200</li> </ul>

Tip: Remember to order end-of-run trim and vertical corner trim packages.

Specification Information

Width	Style Number	U.S. Base Price
-------	--------------	-----------------

54"H

24"	<b>TSAPL5424</b>	\$ 796
30"	<b>TSAPL5430</b>	\$ 861
36"	<b>TSAPL5436</b>	\$ 908
42"	<b>TSAPL5442</b>	\$1020
48"	<b>TSAPL5448</b>	\$1074
60"	<b>TSAPL5460</b>	\$1152

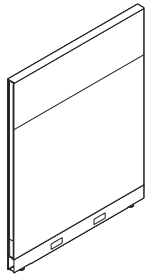

Panels

Segmentation

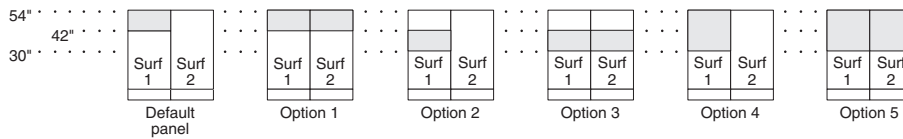

Tip: Shaded area represents accent skin. This skin can be specified in different fabric from base skin.



**For Canadian Pricing**

Multiply U.S. Price by the Canadian price factor.

► See page 1 for details.

# 66"H Segmented Panels

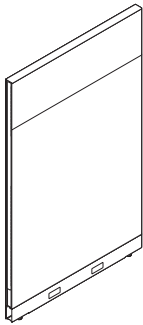

Standard Includes		Required to Specify
<ul style="list-style-type: none"> <li>▶ Need help? Product details, page 12</li> </ul>	<ul style="list-style-type: none"> <li>Panel with segmented, fabric surfaces: Kick standard fabric price group A</li> <li>Base covers with receptacle knockouts: paint price group 1</li> <li>Top cap (low height): paint price group 1</li> <li>Top cap aligner: black plastic</li> <li>Universal connector package</li> <li>Frame: 0835 Black only</li> </ul>	<ol style="list-style-type: none"> <li>1 Style number</li> <li>2 Fabric color number for base skin; surface 1</li> <li>3 Fabric color number for accent skin; surface 1</li> <li>4 Fabric color number for base skin; surface 2</li> <li>5 Fabric color number for accent skin; surface 2</li> <li>6 Paint color number for top cap and base covers</li> <li>7 Options, if selected (see below)</li> </ol> <p>▶ See <i>Surface Materials</i>, page 360.</p>

Options	U.S. Price	Required to Specify
<b>Surface Materials</b> <b>Top cap and base covers</b> <ul style="list-style-type: none"> <li>Paint price group 1</li> <li>Paint price group 2</li> <li>Paint price group 3</li> </ul>	No cost +\$ 16 +\$ 34	Specify paint color number. Specify paint color number. Specify paint color number.
<b>Panel surface</b> <ul style="list-style-type: none"> <li>Kick standard fabric price group A</li> <li>Fabric price group 1</li> <li>Fabric price group 2</li> <li>Fabric price group 3</li> <li>Fabric price group 4</li> <li>Fabric price group 5</li> <li>Fabric price group COM</li> </ul>	No cost +\$ 10 +\$ 64 +\$ 96 +\$240 +\$348 +\$122	Specify fabric color number. Specify fabric color number. Specify fabric color number. Specify fabric color number. Specify fabric color number. Specify fabric color number. Specify fabric color number. ▶ See <i>Understanding Customer's Own Material (COM)</i> , page 364.
<b>Accent skin surface</b> <ul style="list-style-type: none"> <li>Kick standard fabric price group A</li> <li>Fabric price group 1</li> <li>Fabric price group 2</li> <li>Fabric price group 3</li> <li>Fabric price group 4</li> <li>Fabric price group COM</li> </ul>	No cost +\$ 3 +\$ 11 +\$ 21 +\$ 61 +\$ 33	Specify fabric color number. Specify fabric color number. Specify fabric color number. Specify fabric color number. Specify fabric color number. Specify fabric color number. ▶ See <i>Understanding Customer's Own Material (COM)</i> , page 364.
<b>Top Cap</b> <ul style="list-style-type: none"> <li>High top cap with knockouts to accommodate cable routing (increases panel height by 1<sup>3</sup>/<sub>4</sub>"</li> </ul>	+\$ 47	Specify with <i>high top cap</i> .
<b>Electrical</b> <b>Factory-installed powerway at base</b> <ul style="list-style-type: none"> <li>3-circuit powerway with shared neutral</li> <li>3-circuit powerway with separate neutrals</li> <li>4-circuit (3+D) powerway</li> <li>4-circuit (3I+1) powerway</li> <li>4-circuit (2+2) powerway</li> </ul>	+\$208 +\$258 +\$244 +\$306 +\$306	Specify with <i>3-circuit power; shared neutrals</i> . Specify with <i>3-circuit power; separate neutrals</i> . Specify with <i>4-circuit power; 3+D wiring</i> . Specify with <i>4-circuit power; 3I+1 wiring</i> . Specify with <i>4-circuit power; 2+2 wiring</i> .
<b>Factory-included powerway for field installation for use in New York City</b> <ul style="list-style-type: none"> <li>3-circuit powerway with shared neutral</li> <li>3-circuit powerway with separate neutrals</li> <li>4-circuit (3+D) powerway</li> <li>4-circuit (3I+1) powerway</li> <li>4-circuit (2+2) powerway</li> </ul>	+\$208 +\$258 +\$244 +\$306 +\$306	Specify with <i>3-circuit power; shared neutrals; not installed</i> . Specify with <i>3-circuit power; separate neutrals; not installed</i> . Specify with <i>4-circuit power; 3+D wiring; not installed</i> . Specify with <i>4-circuit power; 3I+1 wiring; not installed</i> . Specify with <i>4-circuit power; 2+2 wiring; not installed</i> .

Tip: To price a panel with two base skin surfaces in different fabric price groups, add the two fabric price group option prices together and divide by two; then add the result to the panel base price.

Tip: Factory-included powerway for field installation option replaces need to order separate powerways.

Tip: Field-installed powerways can be ordered through Kick Service Parts.

▶ Options, continued on next page

► Options, continued from previous page

	Options	U.S. Price	Required to Specify
<b>Segmentation</b> ► See below.	• Option 1	+\$126	Specify with option 1.
	• Option 2	+\$126	Specify with option 2.
	• Option 3	+\$382	Specify with option 3.
	• Option 4	+\$ 28	Specify with option 4.
	• Option 5	+\$173	Specify with option 5.
	• Option 6	+\$148	Specify with option 6.
	• Option 7	+\$472	Specify with option 7.
	• Option 8	+\$148	Specify with option 8.
	• Option 9	+\$472	Specify with option 9.
	• Option 10	+\$ 26	Specify with option 10.
	• Option 11	+\$157	Specify with option 11.

Tip: Remember to order end-of-run trim and vertical corner trim packages.

Related Products	
• Panel trim	► Page 186
• Panel connectors	► Page 191
• Panel wiring and cabling	► Page 196
• Worksurface-height power and communication access	► Page 200

**Specification Information**

Width	Style Number	U.S. Base Price
-------	--------------	-----------------

66"H		
24"	<b>TSAPL6624</b>	\$ 806
30"	<b>TSAPL6630</b>	\$ 889
36"	<b>TSAPL6636</b>	\$ 943
42"	<b>TSAPL6642</b>	\$1042
48"	<b>TSAPL6648</b>	\$1131
60"	<b>TSAPL6660</b>	\$1256

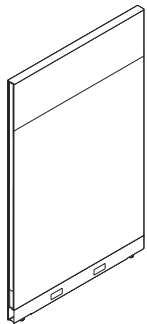

Panels

**Segmentation**

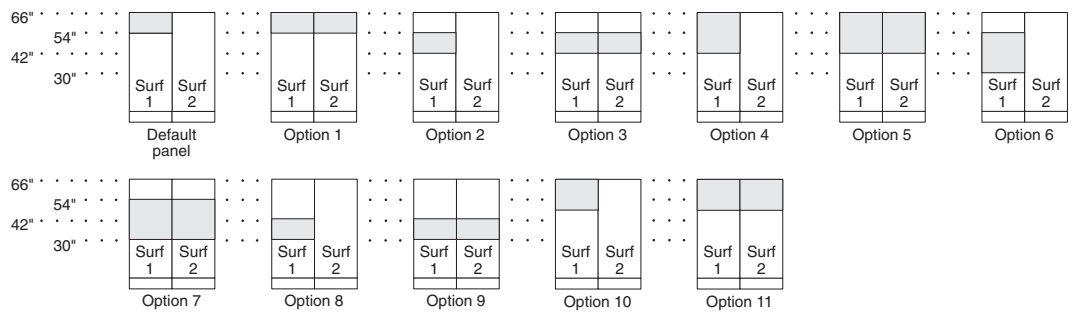

Tip: Shaded area represents accent skin. This skin can be specified in different fabric from base skin.

 **For Canadian Pricing**  
 Multiply U.S. Price by the Canadian price factor.  
 ► See page 1 for details.

# Panel Stackers

## Tackable Acoustical and Glass

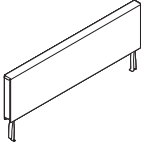

*Tip: To price a panel with two fabric surface materials in different price groups, add the two fabric price group option prices together and divide by 2; then add the result to the panel base price.*

*Tip: Remember to order end-of-run trim and vertical corner trim packages.*

*Tip: Remember to order change-of-height connectors.*

*Tip: When adding a stacker to existing panels with a power or cable pole connected at L-, T-, or X- corner, the universal panel connector can not be used. Order service part **TS100574SR** and use the special panel connector for poles to make the connection.*

Standard Includes	Required to Specify
<ul style="list-style-type: none"> <li>▶ Need help? Product details, page 14</li> <li>• Tackable acoustical stacker with two fabric surfaces, if tackable acoustical stacker selected: Kick standard fabric price group A</li> <li>• Glass insert, if glass stacker selected: 6500 Clear</li> <li>• Border, if glass stacker selected: paint price group 1</li> <li>• Universal connector package</li> <li>• Frame: 0835 Black only</li> <li>• Two stacking fork connectors</li> </ul>	<ol style="list-style-type: none"> <li>1 Style number</li> <li>2 Fabric color number for surface 1 of tackable acoustical stacker, if selected</li> <li>3 Fabric color number for surface 2 of tackable acoustical stacker, if selected</li> <li>4 Paint color number for border, if selected</li> <li>5 Options, if selected (see below)</li> </ol> <p>▶ See <i>Surface Materials</i>, page 360.</p>

Options	U.S. Price	Required to Specify
<b>Surface Materials</b>		
<b>Border on glass stackers</b>		
• Paint price group 1	No cost	Specify paint color number.
• Paint price group 2	+\$ 16	Specify paint color number.
• Paint price group 3	+\$ 34	Specify paint color number.
<b>Fabric surface on tackable acoustical stackers</b>		
• Kick standard fabric price group A	No cost	Specify fabric color number.
• Fabric price group 1	+\$ 10	Specify fabric color number.
• Fabric price group 2	+\$ 64	Specify fabric color number.
• Fabric price group 3	+\$ 96	Specify fabric color number.
• Fabric price group 4	+\$240	Specify fabric color number.
• Fabric price group 5	+\$348	Specify fabric color number.
• Fabric price group COM	+\$122	Specify fabric color number.
▶ See <i>Understanding Customer's Own Material (COM)</i> , page 364.		

<b>Related Products</b>	<ul style="list-style-type: none"> <li>• Panel trim</li> <li>• Panel connectors</li> </ul>	<ul style="list-style-type: none"> <li>▶ Page 186</li> <li>▶ Page 191</li> </ul>
-------------------------	--	--



### For Canadian Pricing

Multiply U.S. Price by the Canadian price factor.

▶ See page 1 for details.

**Specification Information**

**Tackable Acoustical Panel Stackers**

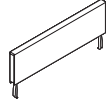

**Glass Panel Stackers**

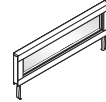

Width	Style Number	U.S. Base Price	Style Number	U.S. Base Price
-------	--------------	-----------------	--------------	-----------------

**12"H**

24"	<b>TSAPS1224T</b>	\$447	<b>TSAPS1224G</b>	\$ 753
30"	<b>TSAPS1230T</b>	\$464	<b>TSAPS1230G</b>	\$ 786
36"	<b>TSAPS1236T</b>	\$504	<b>TSAPS1236G</b>	\$ 856
42"	<b>TSAPS1242T</b>	\$566	<b>TSAPS1242G</b>	\$ 961
48"	<b>TSAPS1248T</b>	\$601	<b>TSAPS1248G</b>	\$1019
60"	<b>TSAPS1260T</b>	\$688	<b>TSAPS1260G</b>	\$1162
72"	<b>TSAPS1272T</b>	\$700	<b>TSAPS1272G</b>	\$1174

**18"H**

24"	<b>TSAPS1824T</b>	\$517	<b>TSAPS1824G</b>	\$ 897
30"	<b>TSAPS1830T</b>	\$550	<b>TSAPS1830G</b>	\$ 936
36"	<b>TSAPS1836T</b>	\$607	<b>TSAPS1836G</b>	\$1026
42"	<b>TSAPS1842T</b>	\$677	<b>TSAPS1842G</b>	\$1145
48"	<b>TSAPS1848T</b>	\$715	<b>TSAPS1848G</b>	\$1210
60"	<b>TSAPS1860T</b>	\$822	<b>TSAPS1860G</b>	\$1390
72"	<b>TSAPS1872T</b>	\$831	<b>TSAPS1872G</b>	\$1406

**24"H**

24"	<b>TSAPS2424T</b>	\$540	<b>TSAPS2424G</b>	\$ 943
30"	<b>TSAPS2430T</b>	\$580	<b>TSAPS2430G</b>	\$ 980
36"	<b>TSAPS2436T</b>	\$640	<b>TSAPS2436G</b>	\$1074
42"	<b>TSAPS2442T</b>	\$710	<b>TSAPS2442G</b>	\$1198
48"	<b>TSAPS2448T</b>	\$748	<b>TSAPS2448G</b>	\$1267
60"	<b>TSAPS2460T</b>	\$858	<b>TSAPS2460G</b>	\$1456
72"	<b>TSAPS2472T</b>	\$871	<b>TSAPS2472G</b>	\$1472

Panels



**For Canadian Pricing**  
 Multiply U.S. Price by the Canadian price factor.  
 ▶ See page 1 for details.

# Panel Trim

## Vertical End-of-Run Trim



Standard Includes		Required to Specify
<ul style="list-style-type: none"> <li>▶ Need help? Product details, page 22</li> </ul>	<ul style="list-style-type: none"> <li>• End-of-run trim: paint price group 1</li> <li>• One low trim end cap: plastic to match paint</li> </ul>	<ul style="list-style-type: none"> <li>1 Style number</li> <li>2 Paint color number for trim</li> <li>3 Options, if selected (see below)</li> <li>▶ See <i>Surface Materials</i>, page 360.</li> </ul>

Options	U.S. Price	Required to Specify
<b>Surface Materials</b> <ul style="list-style-type: none"> <li>• Paint price group 1</li> <li>• Paint price group 2</li> <li>• Paint price group 3</li> </ul>	No cost +\$16 +\$34	Specify paint color number. Specify paint color number. Specify paint color number.
<b>End Cap</b> <ul style="list-style-type: none"> <li>• High end cap</li> </ul>	No cost	Specify <i>with high end cap</i> .

Specification Information		
Corresponding Panel Height	Style Number	U.S. Base Price
42"	<b>TSAPTE42</b>	\$83
48"	<b>TSAPTE48</b>	\$83
54"	<b>TSAPTE54</b>	\$83
60"	<b>TSAPTE60</b>	\$83
66"	<b>TSAPTE66</b>	\$83
72"	<b>TSAPTE72</b>	\$83
78"	<b>TSAPTE78</b>	\$83
:	:	:



**For Canadian Pricing**  
 Multiply U.S. Price by the Canadian price factor.  
 ▶ See page 1 for details.

## Vertical In-Line Change-of-Height Trim

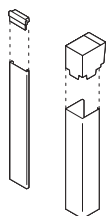

Tip: Remember to order change-of-height connector package.  
▶ Page 191

Standard Includes		Required to Specify
▶ Need help? Product details, page 22	<ul style="list-style-type: none"> <li>Change-of-height trim: paint price group 1</li> <li>Slim profile: one plastic low trim end cap to match paint</li> <li>Cable routing capacity: one plastic high trim end cap to match paint</li> </ul>	1 Style number 2 Paint color number for trim 3 Options, if selected (see below) ▶ See <i>Surface Materials</i> , page 360.

Options	U.S. Price	Required to Specify
<b>Surface Materials</b>	<ul style="list-style-type: none"> <li>Paint price group 1: No cost</li> <li>Paint price group 2: +\$16</li> <li>Paint price group 3: +\$34</li> </ul>	Specify paint color number. Specify paint color number. Specify paint color number.
<b>End Cap</b>	<ul style="list-style-type: none"> <li>Slim profile: high end cap: No cost</li> </ul>	Specify with high end cap.

Specification Information		
Height	Style Number	U.S. Base Price

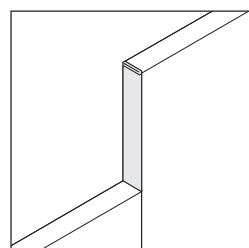

Slim Profile		
6"	<b>TSAPTXS6</b>	\$83
12"	<b>TSAPTXS12</b>	\$83
18"	<b>TSAPTXS18</b>	\$83
24"	<b>TSAPTXS24</b>	\$83
36"	<b>TSAPTXS36</b>	\$83
:	:	:

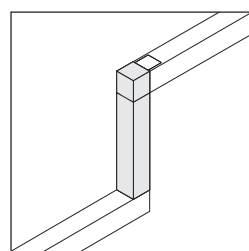

With Cable-Routing Capacity		
6"	<b>TSAPTXT6</b>	\$83
12"	<b>TSAPTXT12</b>	\$83
18"	<b>TSAPTXT18</b>	\$83
24"	<b>TSAPTXT24</b>	\$83
36"	<b>TSAPTXT36</b>	\$83
:	:	:

 **For Canadian Pricing**  
 Multiply U.S. Price by the Canadian price factor.  
 ▶ See page 1 for details.

## Vertical Corner Trim Packages

Standard Includes	Required to Specify
<ul style="list-style-type: none"> <li>▶ Need help? Product details, page 22</li> <li>• Vertical corner trim: paint price group 1</li> <li>• One low trim end cap: plastic to match paint</li> <li>• Carrier: 0835 Black</li> </ul>	<ul style="list-style-type: none"> <li>1 Style number</li> <li>2 Paint color number for vertical corner trim</li> <li>3 Options, if selected (see below)</li> <li>▶ See <i>Surface Materials</i>, page 360.</li> </ul>

Options	U.S. Price	Required to Specify
<b>Surface Materials</b> <ul style="list-style-type: none"> <li>• Paint price group 1</li> <li>• Paint price group 2</li> <li>• Paint price group 3</li> </ul>	<ul style="list-style-type: none"> <li>No cost</li> <li>+\$16</li> <li>+\$34</li> </ul>	<ul style="list-style-type: none"> <li>Specify paint color number.</li> <li>Specify paint color number.</li> <li>Specify paint color number.</li> </ul>
<b>End Cap</b> <ul style="list-style-type: none"> <li>• High end cap for end-of-run configuration</li> <li>• High end cap for L-configuration</li> <li>• High end cap for T-configuration</li> <li>• High end cap for in-line configuration</li> <li>• High end cap for X-configuration</li> </ul>	<ul style="list-style-type: none"> <li>No cost</li> <li>No cost</li> <li>No cost</li> <li>No cost</li> <li>No cost</li> </ul>	<ul style="list-style-type: none"> <li>Specify <i>with high end cap, end-of-run configuration.</i></li> <li>Specify <i>with high end cap, L-configuration.</i></li> <li>Specify <i>with high end cap, T-configuration.</i></li> <li>Specify <i>with high end cap, in-line configuration.</i></li> <li>Specify <i>with high end cap, X-configuration.</i></li> </ul>

Tip: High end cap for X-configuration is not required on corner trim with back filler.

Specification Information			
• Trim Height	• Carrier Height	• Style Number	• U.S. Base Price

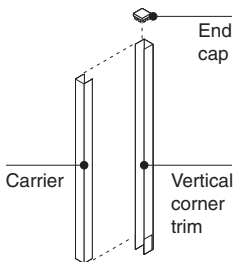

### Vertical Corner Trim

42"	42"	<b>TSAPTC42</b>	\$120
48"	48"	<b>TSAPTC48</b>	\$120
54"	54"	<b>TSAPTC54</b>	\$120
66"	66"	<b>TSAPTC66</b>	\$120
:	:	:	:

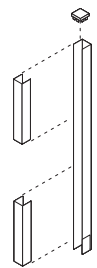

### Vertical Corner Trim with Back Filler

54"	42"	<b>TSAPTCB5442</b>	\$140
66"	42"	<b>TSAPTCB6642</b>	\$140
66"	54"	<b>TSAPTCB6654</b>	\$140
:	:	:	:

Tip: Back filler is required for some T-configurations to make assembly non-sequential and for some T- and X-configurations for cable routing capability only.

## 120° Vertical Corner Trims

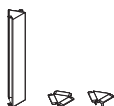

Tip: High end cap is not available for 120° vertical trim.

Standard Includes		Required to Specify
-------------------	--	---------------------

- |   |  |  |
|---|--|--|
| <ul style="list-style-type: none"> <li>▶ Need help? Product details, page 22</li> </ul> | <ul style="list-style-type: none"> <li>• Corner trim: paint price group 1</li> <li>• Low trim end caps for two- or three-way connections (one each): plastic to match paint</li> </ul> | <ul style="list-style-type: none"> <li>1 Style number</li> <li>2 Paint color number for trim</li> <li>3 Options, if selected (see below)</li> <li>▶ See <i>Surface Materials</i>, page 360.</li> </ul> |
|---|--|--|

Surface Materials	Options	U.S. Price	Required to Specify
-------------------	---------	------------	---------------------

- |   |   |   |   |
|---|---|---|---|
| <ul style="list-style-type: none"> <li>• Paint price group 1</li> <li>• Paint price group 2</li> <li>• Paint price group 3</li> </ul> | <ul style="list-style-type: none"> <li>• Paint price group 1</li> <li>• Paint price group 2</li> <li>• Paint price group 3</li> </ul> | <ul style="list-style-type: none"> <li>No cost</li> <li>+\$16</li> <li>+\$34</li> </ul> | <ul style="list-style-type: none"> <li>Specify paint color number.</li> <li>Specify paint color number.</li> <li>Specify paint color number.</li> </ul> |
|---|---|---|---|

### Specification Information

Height	Style Number	U.S. Base Price
6"	<b>TSAPTCY6</b>	\$ 83
12"	<b>TSAPTCY12</b>	\$ 83
18"	<b>TSAPTCY18</b>	\$ 83
24"	<b>TSAPTCY24</b>	\$ 83
42"	<b>TSAPTCY42</b>	\$157
48"	<b>TSAPTCY48</b>	\$157
54"	<b>TSAPTCY54</b>	\$157
66"	<b>TSAPTCY66</b>	\$157
:	:	:

Panels



#### For Canadian Pricing

Multiply U.S. Price by the Canadian price factor.

▶ See page 1 for details.

## Vertical Corner Change-of-Height Trims

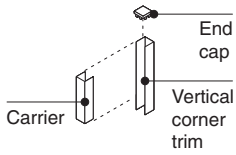

*Tip: Vertical corner change-of-height trims can be used with panel stackers.*

Standard Includes	Required to Specify
<ul style="list-style-type: none"> <li>▶ Need help? Product details, page 22</li> <li>• Vertical corner trim: paint price group 1</li> <li>• One low trim end cap: plastic to match paint</li> <li>• Carrier: 0835 Black</li> </ul>	<ul style="list-style-type: none"> <li>1 Style number</li> <li>2 Paint color number for vertical corner trim</li> <li>3 Options, if selected (see below)</li> <li>▶ See <i>Surface Materials</i>, page 360.</li> </ul>

Options	U.S. Price	Required to Specify
<b>Surface Materials</b> <ul style="list-style-type: none"> <li>• Paint price group 1</li> <li>• Paint price group 2</li> <li>• Paint price group 3</li> </ul>	<ul style="list-style-type: none"> <li>No cost</li> <li>+\$16</li> <li>+\$34</li> </ul>	<ul style="list-style-type: none"> <li>Specify paint color number.</li> <li>Specify paint color number.</li> <li>Specify paint color number.</li> </ul>
<b>End Cap</b> <ul style="list-style-type: none"> <li>• High end cap for end-of-run configuration</li> <li>• High end cap for L-configuration</li> <li>• High end cap for T-configuration</li> <li>• High end cap for in-line configuration</li> <li>• High end cap for X-configuration</li> </ul>	<ul style="list-style-type: none"> <li>No cost</li> <li>No cost</li> <li>No cost</li> <li>No cost</li> <li>No cost</li> </ul>	<ul style="list-style-type: none"> <li>Specify <i>with high end cap, end-of-run configuration.</i></li> <li>Specify <i>with high end cap, L-configuration.</i></li> <li>Specify <i>with high end cap, T-configuration.</i></li> <li>Specify <i>with high end cap, in-line configuration.</i></li> <li>Specify <i>with high end cap, X-configuration.</i></li> </ul>

Specification Information		
• Trim Height	• Style Number	• U.S. Base Price
6"	<b>TSAPTXC6</b>	\$83
12"	<b>TSAPTXC12</b>	\$83
18"	<b>TSAPTXC18</b>	\$83
24"	<b>TSAPTXC24</b>	\$83
:	:	:



**For Canadian Pricing**  
 Multiply U.S. Price by the Canadian price factor.  
 ▶ See page 1 for details.

## Change-of-Height In-Line and Corner Panel Connector Package

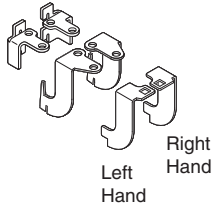

Tip: Change-of-height connections must be used at top of base panel and each stacker whenever possible to increase stability.

Standard Includes	Required to Specify
<ul style="list-style-type: none"> <li>▶ Need help? Product details, page 16</li> <li>• Two corner and two in-line connectors: paint</li> </ul>	<ul style="list-style-type: none"> <li>1 Style number</li> <li>2 Paint color number for connectors</li> <li>▶ See <i>Surface Materials</i>, page 360.</li> </ul>

Specification Information	
Style Number	U.S. Price
TSAPBCOH	\$50

## Wall Start Connector Package

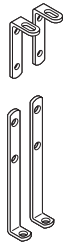

Standard Includes	Required to Specify
<ul style="list-style-type: none"> <li>▶ Need help? Product details, page 16</li> <li>• Wall start connector package: black paint</li> </ul>	<ul style="list-style-type: none"> <li>Style number</li> </ul>

Specification Information	
Style Number	U.S. Price
TSAPBWS66	\$50

## 120° Connectors



Tip: Two-way, 120° connection requires one package. Three-way, 120° connection requires three packages.

Tip: 120° connector does not allow change-of-height connections.

Standard Includes	Required to Specify
<ul style="list-style-type: none"> <li>▶ Need help? Product details, page 16</li> <li>• 120° connectors: 0835 Black</li> <li>• Package includes two 120° connectors and eight screws</li> </ul>	<ul style="list-style-type: none"> <li>Style number</li> </ul>

Specification Information	
Style Number	U.S. Price
<b>One Package</b>	
TSAPB120	\$ 50
<b>Twelve Packages</b>	
TSAPB120P	\$504



**For Canadian Pricing**  
Multiply U.S. Price by the Canadian price factor.  
▶ See page 1 for details.

### Off-Module Connector—Universal

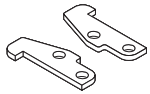

Top brackets

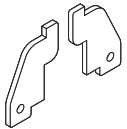

Bottom brackets

Standard Includes	Required to Specify
<ul style="list-style-type: none"> <li>▶ Need help? Product details, page 16</li> <li>• Universal off-module connector: black only</li> </ul>	Style number

#### Specification Information

Style Number	U.S. Price
<b>TSAPBOM</b>	\$50

### Off-Module Connectors—Panel Width-Specific

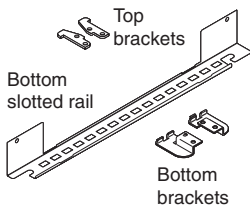

Bottom slotted rail

Top brackets

Bottom brackets

Standard Includes	Required to Specify
<ul style="list-style-type: none"> <li>▶ Need help? Product details, page 16</li> <li>• Panel off-module connector: black only</li> </ul>	Style number

#### Specification Information

Style Number	U.S. Price
<b>TSAPBOM24</b>	\$196
<b>TSAPBOM30</b>	\$214
<b>TSAPBOM36</b>	\$228
<b>TSAPBOM42</b>	\$242
<b>TSAPBOM48</b>	\$255
<b>TSAPBOM60</b>	\$271



**For Canadian Pricing**

Multiply U.S. Price by the Canadian price factor.

▶ See page 1 for details.

# Sliding Panel Doors

For Use with Kick

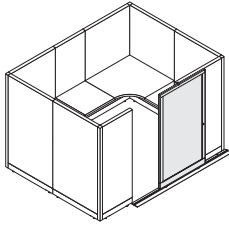

*Tip: The sliding door is located outside of the panel system when installed in the standard position.*

*Tip: The standard door is handed and non-locking. When a lock option is specified the lock will be on the trail end of the door. The illustration above shows a left-handed sliding door. If a lock option is specified, the lock will be on the right (trail) side of the door.*

*Tip: Width of host panel should always be equal to the width of sliding door.*

*Tip: Height of host and receiving panels must match height of door.*

*Tip: Remember to specify lock cylinder and key separately.*

▶ Lock Cylinders, page 374

*Tip: When attaching the sliding door to an Answer panel, a junction stabilizer bracket is available for added rigidity to the host panel. If a host and/or receiving panel run exceeds 4', a junction stabilizer bracket must be applied to the door end of the host and/or receiving panel run. On long runs, apply a junction stabilizer bracket or perpendicular panel every 8'.*

Standard Includes		Required to Specify
▶ Need help? Product details, page 24	<ul style="list-style-type: none"> <li>Panel door frame: paint price group 1</li> <li>Panel door infill: 6625 Translucent plastic</li> <li>Floor track: paint price group 1</li> <li>Attachment bracket: paint price group 1</li> </ul>	1 Style number 2 Paint color number for panel door frame, floor track, and attachment bracket 3 Options, if selected (see below) ▶ See <i>Surface Materials</i> , page 360.

Options	U.S. Price	Required to Specify
<b>Surface Materials</b>	<ul style="list-style-type: none"> <li>Paint price group 1: No cost</li> <li>Paint price group 2: +\$ 16</li> </ul>	Specify paint color number. Specify paint color number.
<b>Panel door infill</b>	<ul style="list-style-type: none"> <li>6500 Clear Tempered glass: +\$379</li> <li>6541 White laminated glass: +\$594</li> </ul>	Specify with 6500 Clear glass. Specify with 6541 White laminated glass.
<b>Door Hand</b>	<ul style="list-style-type: none"> <li>Left-hand sliding door: No cost</li> <li>Right-hand sliding door: No cost</li> </ul>	Specify with left-hand door. Specify with right-hand door.
<b>Door Lock</b>	<ul style="list-style-type: none"> <li>Lock: +\$492</li> </ul>	Specify with lock. ▶ See <i>Lock and Keying</i> , page 374

Specification Information				
Dimensions			Style	U.S.
D	W	H	Number	Base Price
:	:	:	:	:
:	:	:	:	:

Kick Options Doors				
1¼"	36"	66"	<b>TSAPDS06636</b>	\$3647
1¼"	42"	66"	<b>TSAPDS06642</b>	\$3863
1¼"	36"	78"	<b>TSAPDS07836</b>	\$3974
1¼"	42"	78"	<b>TSAPDS07842</b>	\$4185
:	:	:	:	:



## For Canadian Pricing

Multiply U.S. Price by the Canadian price factor.

▶ See page 1 for details.



---

# Specifying Wiring and Cabling

<b>Panel Wiring and Cabling</b>	<b>196</b>
<b>Worksurface-Height Power and Communication Access</b>	<b>200</b>

# Panel Wiring and Cabling

## Duplex Receptacles



Tip: You must specify receptacle to match wiring schematic used in other power components.

Tip: For additional color choices, see the Avenir Systems Furniture Specification Guide.

Standard Includes	Required to Specify
<ul style="list-style-type: none"> <li>Need help? Product details, page 42</li> <li>Package of six powerway receptacles: 6000 Black plastic</li> </ul>	<ul style="list-style-type: none"> <li>1 Style number</li> <li>2 Options, if selected (see below)</li> </ul>

Options	U.S. Price	Required to Specify
<ul style="list-style-type: none"> <li><b>Controlled Stamp</b></li> <li>No stamp</li> <li>Controlled stamp</li> </ul>	<ul style="list-style-type: none"> <li>No cost</li> <li>+\$5</li> </ul>	<ul style="list-style-type: none"> <li>Specify <i>with no stamp</i>.</li> <li>Specify <i>with controlled stamp</i></li> </ul>

Specification Information					
Description	Size	Style Number	U.S. Base Price	Style Number	U.S. Base Price

			15-Amp Receptacles		20-Amp Receptacles	
<b>3-Circuit with Shared Neutral</b>						
Line 1	Standard size	<b>TSAE31DA15SB</b>	\$346		<b>TSAE31DA20SB</b>	\$ 517
Line 2	Standard size	<b>TSAE32DA15SB</b>	\$346		<b>TSAE32DA20SB</b>	\$ 517
Line 3	Standard size	<b>TSAE33DA15SB</b>	\$346		<b>TSAE33DA20SB</b>	\$ 517
<b>3-Circuit with Separate Neutral</b>						
Line A	Standard size	<b>TSAE3ADD15SB</b>	\$517		<b>TSAE3ADD20SB</b>	\$ 791
Line B	Standard size	<b>TSAE3BDD15SB</b>	\$517		<b>TSAE3BDD20SB</b>	\$ 791
Line C	Larger size	<b>TSAE3CDD15SB</b>	\$673		<b>TSAE3CDD20SB</b>	\$1020
<b>4-Circuit 3+D</b>						
Line 1	Standard size	<b>TSAE31DA15SB</b>	\$346		<b>TSAE31DA20SB</b>	\$ 517
Line 2	Standard size	<b>TSAE32DA15SB</b>	\$346		<b>TSAE32DA20SB</b>	\$ 517
Line 3	Standard size	<b>TSAE33DA15SB</b>	\$346		<b>TSAE33DA20SB</b>	\$ 517
Line 4	Larger size	<b>TSAE34DA15SB</b>	\$449		<b>TSAE34DA20SB</b>	\$ 673
<b>4-Circuit with 3I+1 Wiring</b>						
Line 1	Standard size	<b>TSAE31DC15SB</b>	\$517		<b>TSAE31DC20SB</b>	\$ 791
Line 2	Standard size	<b>TSAE32DC15SB</b>	\$517		<b>TSAE32DC20SB</b>	\$ 791
Line 3	Standard size	<b>TSAE33DC15SB</b>	\$517		<b>TSAE33DC20SB</b>	\$ 791
Line 4	Larger size	<b>TSAE34DC15SB</b>	\$673		<b>TSAE34DC20SB</b>	\$1020
<b>4-Circuit with 2+2 Wiring</b>						
Line 1	Standard size	<b>TSAE31DB15SB</b>	\$384		<b>TSAE31DB20SB</b>	\$ 580
Line 2	Standard size	<b>TSAE32DB15SB</b>	\$384		<b>TSAE32DB20SB</b>	\$ 580
Line 3	Larger size	<b>TSAE33DB15SB</b>	\$517		<b>TSAE33DB20SB</b>	\$ 791
Line 4	Larger size	<b>TSAE34DB15SB</b>	\$517		<b>TSAE34DB20SB</b>	\$ 791



**For Canadian Pricing**  
 Multiply U.S. Price by the Canadian price factor.  
 ▶ See page 1 for details.

## 2" x 2" Power Poles



Standard Includes	Required to Specify
-------------------	---------------------

- |   |  |  |
|---|--|--|
| <ul style="list-style-type: none"> <li>▶ Need help? Product details, page 44</li> </ul> | <ul style="list-style-type: none"> <li>• Power pole: paint price group 1</li> <li>• Ceiling trim plate: 4790 Sodium paint only</li> <li>• Harness with 3-circuit, with shared neutral, or with 4-circuit 3+D</li> <li>• Junction box</li> <li>• Mounting brackets</li> <li>• Pair of corner change-of-height connectors</li> </ul> | <ul style="list-style-type: none"> <li>1 Style number</li> <li>2 Paint color number for power pole</li> <li>3 Options, if selected (see below)</li> <li>▶ See <i>Surface Materials</i>, page 360.</li> </ul> |
|---|--|--|

Options	U.S. Price	Required to Specify
---------	------------	---------------------

<b>Surface Materials</b>	<ul style="list-style-type: none"> <li>• Paint price group 1</li> <li>• Paint price group 2</li> <li>• Paint price group 3</li> </ul>	No cost +\$16 +\$34	Specify paint color number. Specify paint color number. Specify paint color number.
<b>Wiring Schematics</b>	<b>Three-circuit</b> <ul style="list-style-type: none"> <li>• Separate neutrals</li> </ul>	+\$19	Specify <i>with separate neutrals</i> .
	<b>Four-circuit</b> <ul style="list-style-type: none"> <li>• 3I+1 wiring schematic</li> <li>• 2+2 wiring schematic</li> </ul>	+\$19 +\$19	Specify <i>with 3I+1 wiring</i> . Specify <i>with 2+2 wiring</i> .

### Specification Information

Panel Height	Style Number	U.S. Base Price	Style Number	U.S. Base Price
	<b>3-Circuit</b>		<b>4-Circuit</b>	
42"	<b>TSAEP342B</b>	\$730	<b>TSAEP442B</b>	\$827
48"	<b>TSAEP348B</b>	\$730	<b>TSAEP448B</b>	\$827
54"	<b>TSAEP354B</b>	\$730	<b>TSAEP454B</b>	\$827
66"	<b>TSAEP366B</b>	\$730	<b>TSAEP466B</b>	\$827



**For Canadian Pricing**  
 Multiply U.S. Price by the Canadian price factor.  
 ▶ See page 1 for details.

## 2" x 2" Cable Poles

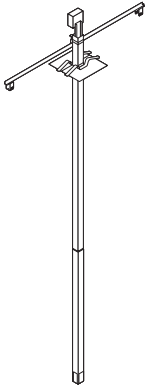

Standard Includes		Required to Specify
<ul style="list-style-type: none"> <li>▶ Need help? Product details, page 44</li> </ul>	<ul style="list-style-type: none"> <li>• Cable pole: paint price group 1</li> <li>• Ceiling trim plate: 4790 Sodium paint only</li> <li>• Junction box</li> <li>• Mounting brackets</li> <li>• Pair of corner change-of-height connectors</li> </ul>	<ul style="list-style-type: none"> <li>1 Style number</li> <li>2 Paint color number for cable pole</li> <li>3 Options, if selected (see below)</li> <li>▶ See <i>Surface Materials</i>, page 360.</li> </ul>

Options	U.S. Price	Required to Specify
<b>Surface Materials</b> <ul style="list-style-type: none"> <li>• Paint price group 1</li> <li>• Paint price group 2</li> <li>• Paint price group 3</li> </ul>	<ul style="list-style-type: none"> <li>No cost</li> <li>+\$16</li> <li>+\$34</li> </ul>	<ul style="list-style-type: none"> <li>Specify paint color number.</li> <li>Specify paint color number.</li> <li>Specify paint color number.</li> </ul>

Specification Information		
Panel Height	Style Number	U.S. Base Price
42"	<b>TSAEPC42</b>	\$664
48"	<b>TSAEPC48</b>	\$664
54"	<b>TSAEPC54</b>	\$664
66"	<b>TSAEPC66</b>	\$664
:	:	:



**For Canadian Pricing**  
 Multiply U.S. Price by the Canadian price factor.  
 ▶ See page 1 for details.

## Base Power-Ins

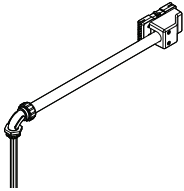

Standard Includes	Required to Specify
<ul style="list-style-type: none"> <li>▶ Need help? Product details, page 46</li> <li>• Power infeed cover: black plastic only</li> <li>• 6' long, 1/2" diameter conduit: black plastic only</li> <li>• 3-circuit with shared neutral or 4-circuit 3+D</li> </ul>	<ul style="list-style-type: none"> <li>1 Style number</li> <li>2 Options, if selected (see below)</li> <li>▶ See <i>Surface Materials</i>, page 360.</li> </ul>

Options	U.S. Price	Required to Specify
<b>Wiring Schematics</b> <b>Three-circuit</b> <ul style="list-style-type: none"> <li>• Separate neutrals</li> </ul>	+\$60	Specify with separate neutrals.
<b>Four-circuit</b> <ul style="list-style-type: none"> <li>• 3I+1 wiring schematic</li> <li>• 2+2 wiring schematic</li> </ul>	+\$74 +\$74	Specify with 3I+1 wiring. Specify with 2+2 wiring.

Specification Information	
<ul style="list-style-type: none"> <li>• <b>Style Number</b></li> <li>•</li> <li>•</li> <li>•</li> </ul>	<ul style="list-style-type: none"> <li>• <b>U.S. Base Price</b></li> <li>•</li> <li>•</li> <li>•</li> </ul>

### 3-Circuit Shared Neutral Wiring Schematic

<b>TSAE98669B</b>	\$420
<b>For Use in San Francisco</b>	
<b>TSAE98669SFB</b>	\$420
•	•

### 4-Circuit 3+D Wiring Schematic



<b>TSAE986694B</b>	\$460
<b>For Use in San Francisco</b>	
<b>TSAE98669SFB</b>	\$460
•	•

Wiring and Cabling

**For Canadian Pricing**  
 Multiply U.S. Price by the Canadian price factor.  
 ▶ See page 1 for details.

# Worksurface-Height Power and Communication Access

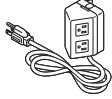
## Receptacle Packages

Standard Includes		Required to Specify	
<ul style="list-style-type: none"> <li>▶ Need help? Product details, page 52</li> </ul>	<ul style="list-style-type: none"> <li>• Package of three</li> <li>• Duplex receptacles: black plastic only</li> <li>• 9' cord with three-prong plug: black plastic only</li> </ul>	Style number	
Specification Information			
Panel-Mounted Receptacle Package		Worksurface-Mounted Receptacle Package	
			
• Style Number	• U.S. Price	• Style Number	• U.S. Price
•	•	•	•
•	•	•	•
<b>TSAERP</b>	\$277	<b>TSAERPW</b>	\$277
•	•	•	•

## Communication Module Packages

*Tip: Many of the AMP, AT&T, Krone, Leviton, and other commercially available data terminals can be used—terminals must be of a design that will snap into 0.695 x 0.650, 0.590 x 0.790, or 0.590 x 0.750 openings, in 0.064 maximum thick face plates.*

*Tip: Order jacks by calling any of the manufacturers listed below:*

- AMP Corporation  
1.800.522.6752
- Leviton  
1.800.722.2082
- Lucent  
1.800.344.0223
- Krone  
1.800.775.5766
- Panduit  
1.800.777.3300

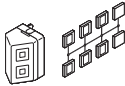
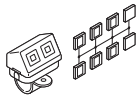
Standard Includes		Required to Specify	
<ul style="list-style-type: none"> <li>▶ Need help? Product details, page 52</li> </ul>	<ul style="list-style-type: none"> <li>• Package of three</li> <li>• Communication housing includes face plates to accommodate customer-supplied voice/data jacks: black plastic only</li> </ul>	Style number	
Specification Information			
Panel-Mounted Communication Module Package		Worksurface-Mounted Communication Module Package	
			
• Style Number	• U.S. Price	• Style Number	• U.S. Price
•	•	•	•
•	•	•	•
<b>TSAERDP</b>	\$177	<b>TSAERDW</b>	\$177
•	•	•	•



### For Canadian Pricing

Multiply U.S. Price by the Canadian price factor.

▶ See page 1 for details.

---

# Specifying TS Series Worksurfaces

<b>TS Series Straight Worksurfaces</b>	<b>202</b>
<b>TS Series Transition Worksurfaces</b>	<b>203</b>
<b>TS Series Straight Corner Worksurfaces</b>	<b>204</b>
<b>TS Series Curved Corner Worksurfaces</b>	<b>205</b>
<b>TS Series Left-Hand Extended Curved Corner Worksurfaces</b>	<b>206</b>
<b>TS Series Right-Hand Extended Curved Corner Worksurfaces</b>	<b>207</b>
<b>TS Series 120° Corner Worksurfaces</b>	<b>208</b>
<b>TS Series Peninsula Worksurfaces</b>	<b>209</b>
<b>TS Series Angled Peninsula Worksurfaces</b>	<b>210</b>
<b>TS Series Spanner Worksurfaces</b>	<b>211</b>
<b>TS Series Visitor and Linking Worksurfaces</b>	<b>212</b>
<b>TS Series Transaction Worksurfaces</b>	<b>213</b>
<b>TS Series Worksurface Legs and Supports</b>	<b>214</b>
<b>Worksurface-Height Power and Communication Access</b>	<b>216</b>
<b>Worksurface Accessories</b>	<b>261</b>

# TS Series Straight Worksurfaces

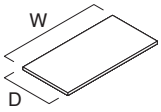

Tip: Long work surface spans require additional support.  
▶ Page 215

Standard Includes		Required to Specify
▶ Need help? Product details, page 62	<ul style="list-style-type: none"> <li>• 1<math>\frac{3}{16}</math>"-thick work surface: Low-Pressure Laminate price group 1</li> <li>• 3 mm radius profile edge on user's side: plastic</li> <li>• Side and back edges: plastic default to match user's side</li> </ul>	<ol style="list-style-type: none"> <li>1 Style number</li> <li>2 Low-Pressure Laminate color number for work surface</li> <li>3 Plastic edge band color number for work surface</li> </ol> <p>▶ See <i>Surface Materials</i>, page 360.</p>

Related Products	
<ul style="list-style-type: none"> <li>• Work surface-height power and communication access</li> <li>• TS Series Work surface legs and supports</li> <li>• Reinforcing channel</li> <li>• Grommet package</li> </ul>	<ul style="list-style-type: none"> <li>▶ Page 200</li> <li>▶ Page 214</li> <li>▶ Page 215</li> <li>▶ Page 216</li> </ul>

## Specification Information

Dimensions		Style Number	U.S. Price
D	W	LPL	
18"	24"	<b>TSAWLR1824</b>	\$191
18"	30"	<b>TSAWLR1830</b>	\$198
18"	36"	<b>TSAWLR1836</b>	\$225
18"	42"	<b>TSAWLR1842</b>	\$242
18"	48"	<b>TSAWLR1848</b>	\$279
18"	54"	<b>TSAWLR1854</b>	\$325
18"	60"	<b>TSAWLR1860</b>	\$350
18"	66"	<b>TSAWLR1866</b>	\$378
18"	72"	<b>TSAWLR1872</b>	\$393
24"	24"	<b>TSAWLR2424</b>	\$215
24"	30"	<b>TSAWLR2430</b>	\$226
24"	36"	<b>TSAWLR2436</b>	\$245
24"	42"	<b>TSAWLR2442</b>	\$279
24"	48"	<b>TSAWLR2448</b>	\$320
24"	54"	<b>TSAWLR2454</b>	\$365
24"	60"	<b>TSAWLR2460</b>	\$401
24"	66"	<b>TSAWLR2466</b>	\$438
24"	72"	<b>TSAWLR2472</b>	\$449
30"	24"	<b>TSAWLR3024</b>	\$238
30"	30"	<b>TSAWLR3030</b>	\$264
30"	36"	<b>TSAWLR3036</b>	\$290
30"	42"	<b>TSAWLR3042</b>	\$325
30"	48"	<b>TSAWLR3048</b>	\$358
30"	54"	<b>TSAWLR3054</b>	\$410
30"	60"	<b>TSAWLR3060</b>	\$460
30"	66"	<b>TSAWLR3066</b>	\$497
30"	72"	<b>TSAWLR3072</b>	\$540



**For Canadian Pricing**  
Multiply U.S. Price by the Canadian price factor.  
▶ See page 1 for details.

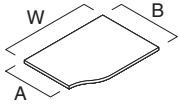

Standard Includes		Required to Specify
▶ Need help? Product details, page 62	<ul style="list-style-type: none"> <li>• 1<math>\frac{3}{16}</math>"-thick work surface: Low-Pressure Laminate price group 1</li> <li>• 3 mm radius profile edge on user's side: plastic</li> <li>• Side and back edges: plastic default to match user's side</li> </ul>	<ol style="list-style-type: none"> <li>1 Style number</li> <li>2 Low-Pressure Laminate color number for work surface</li> <li>3 Plastic edge band color number for work surface</li> </ol> <p>▶ See <i>Surface Materials</i>, page 360.</p>

Related Products	
<ul style="list-style-type: none"> <li>• Work surface-height power and communication access</li> <li>• TS Series Work surface legs and supports</li> <li>• Grommet package</li> </ul>	<ul style="list-style-type: none"> <li>▶ Page 200</li> <li>▶ Page 214</li> <li>▶ Page 216</li> </ul>

Specification Information				
Depth A	B	Width	Style Number LPL	U.S. Price
18"	24"	36"	<b>TSAWLX1236</b>	\$425
18"	24"	42"	<b>TSAWLX1242</b>	\$462
18"	24"	48"	<b>TSAWLX1248</b>	\$554
24"	18"	36"	<b>TSAWLX2136</b>	\$425
24"	18"	42"	<b>TSAWLX2142</b>	\$462
24"	18"	48"	<b>TSAWLX2148</b>	\$554
24"	30"	36"	<b>TSAWLX2336</b>	\$473
24"	30"	42"	<b>TSAWLX2342</b>	\$520
24"	30"	48"	<b>TSAWLX2348</b>	\$618
30"	24"	36"	<b>TSAWLX3236</b>	\$473
30"	24"	42"	<b>TSAWLX3242</b>	\$520
30"	24"	48"	<b>TSAWLX3248</b>	\$618
:	:	:	:	:

TS Series  
Worksurfaces



**For Canadian Pricing**  
Multiply U.S. Price by the  
Canadian price factor.  
▶ See page 1 for details.

# TS Series Straight Corner Worksurfaces

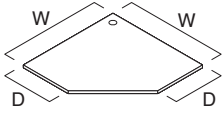

Standard Includes		Required to Specify
<ul style="list-style-type: none"> <li>▶ Need help? Product details, page 62</li> </ul>	<ul style="list-style-type: none"> <li>• 1<math>\frac{3}{16}</math>"-thick work surface: Low-Pressure Laminate price group 1</li> <li>• 3 mm radius profile edge on user's side: plastic</li> <li>• Side and back edges: plastic default to match user's side</li> <li>• Grommet: black plastic only</li> <li>• Corner bracket: black paint only</li> </ul>	<ul style="list-style-type: none"> <li>1 Style number</li> <li>2 Low-Pressure Laminate color number for work surface</li> <li>3 Plastic edge band color number for work surface</li> <li>▶ See <i>Surface Materials</i>, page 360.</li> </ul>

Related Products	
<ul style="list-style-type: none"> <li>• Work surface-height power and communication access</li> <li>• TS Series Work surface legs and supports</li> </ul>	<ul style="list-style-type: none"> <li>▶ Page 200</li> <li>▶ Page 214</li> </ul>

Specification Information			
Dimensions		Style Number	U.S. Price
D	W		
24"	36"	<b>TSAWLCF2436</b>	\$456
24"	42"	<b>TSAWLCF2442</b>	\$525
24"	48"	<b>TSAWLCF2448</b>	\$567
30"	48"	<b>TSAWLCF3048</b>	\$611



**For Canadian Pricing**  
 Multiply U.S. Price by the Canadian price factor.  
 ▶ See page 1 for details.

# TS Series Curved Corner Worksurfaces

TS Series Curved  
Corner Worksurfaces

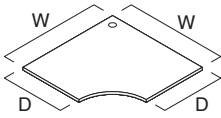

Standard Includes		Required to Specify
▶ Need help? Product details, page 62	<ul style="list-style-type: none"> <li>• 1<math>\frac{3}{16}</math>"-thick worksurface: Low-Pressure Laminate price group 1</li> <li>• 3 mm radius profile edge on user's side: plastic</li> <li>• Side and back edges: plastic default to match user's side</li> <li>• Grommet: black plastic only</li> <li>• Corner bracket: black paint only</li> </ul>	<ol style="list-style-type: none"> <li>1 Style number</li> <li>2 Low-Pressure Laminate color number for worksurface</li> <li>3 Plastic edge band color number for worksurface</li> </ol> <p>▶ See <i>Surface Materials</i>, page 360.</p>

Related Products	
<ul style="list-style-type: none"> <li>• Worksurface-height power and communication access</li> <li>• TS Series Worksurface legs and supports</li> </ul>	<p>▶ Page 200</p> <p>▶ Page 214</p>

Specification Information			
Dimensions		Style Number LPL	U.S. Price
D	W		
18"	36"	<b>TSAWLCC1836</b>	\$520
18"	42"	<b>TSAWLCC1842</b>	\$577
18"	48"	<b>TSAWLCC1848</b>	\$635
24"	36"	<b>TSAWLCC2436</b>	\$501
24"	42"	<b>TSAWLCC2442</b>	\$554
24"	48"	<b>TSAWLCC2448</b>	\$611
30"	48"	<b>TSAWLCC3048</b>	\$707

TS Series  
Worksurfaces

 **For Canadian Pricing**  
Multiply U.S. Price by the  
Canadian price factor.  
▶ See page 1 for details.

# TS Series Left-Hand Extended Curved Corner Worksurfaces

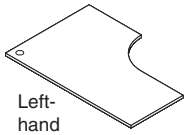

Left-hand

Tip: Long work surface spans require additional support.

▶ Page 215

Standard Includes	Required to Specify
<ul style="list-style-type: none"> <li>▶ Need help? Product details, page 62</li> <li>• 1<math>\frac{3}{16}</math>"-thick work surface: Low-Pressure Laminate price group 1</li> <li>• 3 mm radius profile edge on user's side: plastic</li> <li>• Side and back edges: plastic default to match user's side</li> <li>• Grommet: black plastic only</li> <li>• Corner bracket: black paint only</li> </ul>	<ol style="list-style-type: none"> <li>1 Style number</li> <li>2 Low-Pressure Laminate color number for work surface</li> <li>3 Plastic edge band color number for work surface</li> </ol> <p>▶ See <i>Surface Materials</i>, page 360.</p>

Related Products
<ul style="list-style-type: none"> <li>• Work surface-height power and communication access ▶ Page 200</li> <li>• TS Series Work surface legs and supports ▶ Page 214</li> <li>• Reinforcing channel ▶ Page 215</li> </ul>

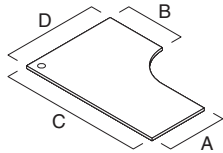

Specification Information					
• Dimensions				• Style Number LPL	• U.S. Price
A	B	C	D		
24"	24"	60"	48"	<b>TSAWLE2264</b>	\$ 826
24"	24"	72"	48"	<b>TSAWLE2274</b>	\$ 985
24"	30"	60"	48"	<b>TSAWLE2364</b>	\$ 850
24"	30"	72"	48"	<b>TSAWLE2374</b>	\$1012
30"	24"	60"	48"	<b>TSAWLE3264</b>	\$ 850
30"	24"	72"	48"	<b>TSAWLE3274</b>	\$1012
30"	30"	60"	48"	<b>TSAWLE3364</b>	\$ 875
30"	30"	72"	48"	<b>TSAWLE3374</b>	\$1041



### For Canadian Pricing

Multiply U.S. Price by the Canadian price factor.

▶ See page 1 for details.

# TS Series Right-Hand Extended Curved Corner Worksurfaces

TS Series Right-Hand  
Extended Curved Corner  
Worksurfaces

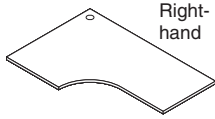

Right-hand

Tip: Long work surface spans require additional support.

▶ Page 215

## Standard Includes

- ▶ Need help? Product details, page 62
- 1 $\frac{3}{16}$ "-thick work surface: Low-Pressure Laminate price group 1
- 3 mm radius profile edge on user's side: plastic
- Side and back edges: plastic default to match user's side
- Grommet: black plastic only
- Corner bracket: black paint only

## Required to Specify

- 1 Style number
  - 2 Low-Pressure Laminate color number for work surface
  - 3 Plastic edge band color number for work surface
- ▶ See *Surface Materials*, page 360.

## Related Products

- Work surface-height power and communication access ▶ Page 200
- TS Series Work surface legs and supports ▶ Page 214
- Reinforcing channel ▶ Page 215

## Specification Information

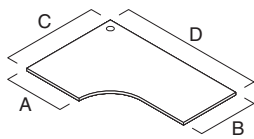

Dimensions				Style Number LPL	U.S. Price
A	B	C	D		
24"	24"	48"	60"	<b>TSAWLE2246</b>	\$ 826
24"	24"	48"	72"	<b>TSAWLE2247</b>	\$ 985
24"	30"	48"	60"	<b>TSAWLE2346</b>	\$ 850
24"	30"	48"	72"	<b>TSAWLE2347</b>	\$1012
30"	24"	48"	60"	<b>TSAWLE3246</b>	\$ 850
30"	24"	48"	72"	<b>TSAWLE3247</b>	\$1012
30"	30"	48"	60"	<b>TSAWLE3346</b>	\$ 875
30"	30"	48"	72"	<b>TSAWLE3347</b>	\$1041
:	:	:	:	:	:



### For Canadian Pricing

Multiply U.S. Price by the Canadian price factor.

▶ See page 1 for details.

# TS Series 120° Corner Worksurfaces

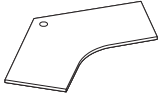

Standard Includes	Required to Specify
<ul style="list-style-type: none"> <li>▶ Need help? Product details, page 62</li> <li>• 1 3/16"-thick worksurface: Low-Pressure Laminate price group 1</li> <li>• 3 mm radius profile edge on user's side: plastic</li> <li>• Side and back edges: plastic default to match user's side</li> <li>• Grommet: black plastic only</li> <li>• Corner bracket: black paint only</li> </ul>	<ul style="list-style-type: none"> <li>1 Style number</li> <li>2 Low-Pressure Laminate color number for worksurface</li> <li>3 Plastic edge band color number for worksurface</li> <li>▶ See <i>Surface Materials</i>, page 360.</li> </ul>

Related Products
<ul style="list-style-type: none"> <li>• Worksurface-height power and communication access ▶ Page 200</li> <li>• TS Series Worksurface legs and supports ▶ Page 214</li> </ul>

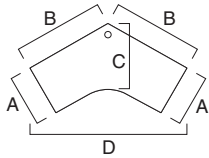

Specification Information					
• Dimensions				• Style Number LPL	• U.S. Price
A	B	C	D		
24"	36"	30 1/2"	63 11/32"	<b>TSAWLY2436</b>	\$ 850
24"	42"	30 1/2"	72 3/4"	<b>TSAWLY2442</b>	\$ 911
24"	48"	30 1/2"	85 5/32"	<b>TSAWLY2448</b>	\$1005
⋮					



**For Canadian Pricing**  
 Multiply U.S. Price by the Canadian price factor.  
 ▶ See page 1 for details.

# TS Series Peninsula Worksurfaces

TS Series Peninsula  
Worksurfaces

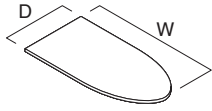

*Tip: Long work surface spans require additional support.*  
▶ Page 215

Standard Includes		Required to Specify
▶ Need help? Product details, page 62	<ul style="list-style-type: none"> <li>• 1<math>\frac{3}{16}</math>"-thick work surface: Low-Pressure Laminate price group 1</li> <li>• 3 mm radius profile edge on user's side: plastic</li> <li>• Side edge: plastic default to match user's side</li> </ul>	<ol style="list-style-type: none"> <li>1 Style number</li> <li>2 Low-Pressure Laminate color number for work surface</li> <li>3 Plastic edge band color number for work surface</li> </ol> <p>▶ See <i>Surface Materials</i>, page 360.</p>

Related Products	
<ul style="list-style-type: none"> <li>• TS Series Worksurface legs and supports</li> <li>• Reinforcing channel</li> </ul>	<ul style="list-style-type: none"> <li>▶ Page 214</li> <li>▶ Page 215</li> </ul>

Specification Information			
Dimensions		Style Number LPL	U.S. Price
D	W		
30"	48"	<b>TSAWLP3048</b>	\$798
30"	60"	<b>TSAWLP3060</b>	\$816
30"	72"	<b>TSAWLP3072</b>	\$832
:	:	:	:

TS Series  
Worksurfaces



**For Canadian Pricing**  
Multiply U.S. Price by the Canadian price factor.  
▶ See page 1 for details.

# TS Series Angled Peninsula Worksurfaces

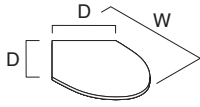

Standard Includes		Required to Specify
▶ Need help? Product details, page 62	<ul style="list-style-type: none"> <li>• 1<sup>3</sup>/<sub>16</sub>"-thick worksurface: Low-Pressure Laminate price group 1</li> <li>• 3 mm radius profile edge on user's side: plastic</li> <li>• Side edge: plastic default to match user's side</li> </ul>	<ol style="list-style-type: none"> <li>1 Style number</li> <li>2 Low-Pressure Laminate color number for worksurface</li> <li>3 Plastic edge band color number for worksurface</li> </ol> <p>▶ See <i>Surface Materials</i>, page 360.</p>

Related Products	
• TS Series Worksurface legs and supports	▶ Page 214

Specification Information			
• Dimensions		• Style	• U.S.
D	W	Number	Price
		LPL	
24"	48"	<b>TSAWLPA2448</b>	\$782
30"	48"	<b>TSAWLPA3048</b>	\$809

 **For Canadian Pricing**  
 Multiply U.S. Price by the Canadian price factor.  
 ▶ See page 1 for details.

# TS Series Spanner Worksurfaces

TS Series Spanner  
Worksurfaces

*Tip: Remember to specify two cantilevers and a post leg to attach spanner worksurface to adjacent worksurfaces on 50" and 62" spanner tops.*

*Tip: Edge profile is applied to front (user's) edge only.*

Standard Includes		Required to Specify
▶ Need help? Product details, page 62	<ul style="list-style-type: none"> <li>• 1<math>\frac{3}{16}</math>"-thick worksurface: Low-Pressure Laminate price group 1</li> <li>• 3 mm radius profile edge on user's front edge: plastic</li> <li>• Side edge: plastic default to match user's side</li> <li>• Cutout</li> </ul>	<ol style="list-style-type: none"> <li>1 Style number</li> <li>2 Low-Pressure Laminate color number for worksurface</li> <li>3 Plastic edge band color number for worksurface</li> </ol> <p>▶ See <i>Surface Materials</i>, page 360.</p>

Related Products	
<ul style="list-style-type: none"> <li>• TS Series Worksurface legs and supports</li> </ul>	▶ Page 214

## Specification Information

Dimensions		Style	U.S.
D	W	Number	Price
:	:	LPL	:
:	:	:	:

### Spanner Worksurfaces for Use with 2" Kick Panels

25"	50"	<b>TSAWLN50</b>	\$429
31"	62"	<b>TSAWLN62</b>	\$511
:	:	:	:

### Spanner Worksurfaces for Use with 3" Panels

25"	51"	<b>TSAWLN51A</b>	\$545
31"	63"	<b>TSAWLN63A</b>	\$700
:	:	:	:

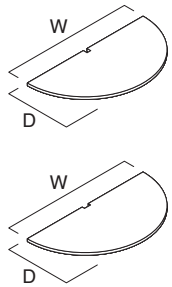

 **For Canadian Pricing**  
Multiply U.S. Price by the Canadian price factor.  
▶ See page 1 for details.

# TS Series Visitor and Linking Worksurfaces

Standard Includes		Required to Specify
<ul style="list-style-type: none"> <li>▶ Need help? Product details, page 62</li> </ul>	<ul style="list-style-type: none"> <li>• 1<math>\frac{3}{16}</math>"-thick worksurface: Low-Pressure Laminate price group 1</li> <li>• 3 mm radius profile edge on user's side: plastic</li> <li>• Side edge: plastic default to match user's side</li> <li>• Cutout on linking worksurface</li> </ul>	<ol style="list-style-type: none"> <li>1 Style number</li> <li>2 Low-Pressure Laminate color number for worksurface</li> <li>3 Plastic edge band color number for worksurface</li> </ol> <ul style="list-style-type: none"> <li>▶ See <i>Surface Materials</i>, page 360.</li> </ul>

Related Products	
<ul style="list-style-type: none"> <li>• Worksurface-height power and communication access</li> <li>• TS Series Worksurface legs and supports</li> </ul>	<ul style="list-style-type: none"> <li>▶ Page 200</li> <li>▶ Page 214</li> </ul>

Specification Information			
Depth Left	Depth Right	Style Number LPL	U.S. Price

## Visitor Worksurfaces For Use With 2" Kick Panels

24"	24"	<b>TSAWL2424</b>	\$440
24"	30"	<b>TSAWL2430</b>	\$491
30"	24"	<b>TSAWL3024</b>	\$491
30"	30"	<b>TSAWL3030</b>	\$554
:	:	:	:

## Linking Worksurfaces For Use With 2" Kick Panels

26"	26"	<b>TSAWL2626</b>	\$469
32"	32"	<b>TSAWL3232</b>	\$525
:	:	:	:

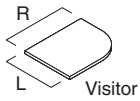

Visitor

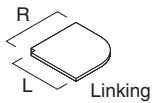

Linking

*Tip: Remember to order cantilevers to connect linking worksurfaces to adjacent worksurfaces.*

▶ Page 215



### For Canadian Pricing

Multiply U.S. Price by the Canadian price factor.

▶ See page 1 for details.

# TS Series Transaction Worksurfaces

For Kick Panels

TS Series Transaction  
Worksurfaces

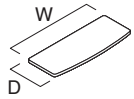

*Tip: Transaction worksurfaces are for use on panels with a low top cap only.*

Standard Includes		Required to Specify
<ul style="list-style-type: none"> <li>▶ Need help? Product details, page 62</li> </ul>	<ul style="list-style-type: none"> <li>• 1<math>\frac{3}{16}</math>"-thick worksurface: Low-Pressure Laminate price group 1</li> <li>• Slight radius profile edge: plastic</li> <li>• Support brackets: black paint only</li> </ul>	<ul style="list-style-type: none"> <li>1 Style number</li> <li>2 Low-Pressure Laminate color number for worksurface</li> <li>3 Plastic edge band color number for worksurface</li> <li>▶ See <i>Surface Materials</i>, page 360.</li> </ul>

Specification Information			
Depth	Width	Style Number LPL	U.S. Price
16"	35"	<b>TSAWLT1636</b>	\$323
16"	41"	<b>TSAWLT1642</b>	\$368
16"	47"	<b>TSAWLT1648</b>	\$387
16"	59"	<b>TSAWLT1660</b>	\$425

TS Series  
Worksurfaces



### For Canadian Pricing

Multiply U.S. Price by the Canadian price factor.

▶ See page 1 for details.

# TS Series Worksurface Legs and Supports

Standard Includes		Required to Specify
<ul style="list-style-type: none"> <li>▶ Need help? Product details, page 66</li> </ul>	<ul style="list-style-type: none"> <li>• Worksurface support: black paint <i>Exception: You can specify paint color choice for cantilever, legs, and on-module end panel.</i></li> <li>• 2¾" adjustable glides on legs</li> <li>• Attachment hardware</li> </ul>	<ul style="list-style-type: none"> <li>1 Style number</li> <li>2 Paint color number for cantilever, legs, and end panel</li> <li>3 Options, if selected (see below)</li> <li>▶ See <i>Surface Materials</i>, page 360.</li> </ul>

Options	U.S. Price	Required to Specify
<b>Surface Materials</b> <b>Post legs and H-legs</b> <ul style="list-style-type: none"> <li>• Paint price group 1</li> <li>• Paint price group 2</li> </ul>	No cost +\$19	Specify paint color number. Specify paint color number.
<b>On-module end panel</b> <ul style="list-style-type: none"> <li>• Paint price group 1</li> <li>• Paint price group 2</li> </ul>	No cost +\$45	Specify paint color number. Specify paint color number.

Specification Information		
Dimensions	Style Number	U.S. Base Price

## Post Leg

27"H	<b>TSATP27</b>	\$193
------	----------------	-------

## H-Legs

11"W	27"H	<b>TSATH2711</b>	\$263
20"W	27"H	<b>TSATH2720</b>	\$323

## On-Module End Panel

24"D	27"H	<b>TSATEP24</b>	\$588
30"D	27"H	<b>TSATEP30</b>	\$671

## Standing Height

24"D	40"H	<b>TSATEP24S</b>	\$698
30"D	40"H	<b>TSATEP30S</b>	\$786

▶ **Specification Information, continued on next page**

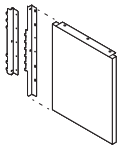
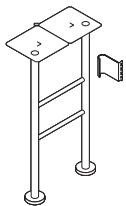
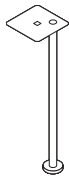

**For Canadian Pricing**  
 Multiply U.S. Price by the Canadian price factor.  
 ▶ See page 1 for details.

► **Specification Information, continued from previous page**

**Specification Information**

• Dimensions	• Style Number	• U.S. Base Price
--------------	----------------	-------------------

**Cantilever with Tie Plate**

16"D 13"H	<b>TSATCANT</b>	\$141
-----------	-----------------	-------

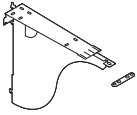

*Tip: Cantilever with tie plate is for use with left-hand, right-hand, or shared application.*

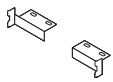

**Side Support Brackets to Connect Worksurface to Panel**

<b>TSATSIDE</b>	\$ 58
-----------------	-------

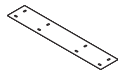

**In-Line Support Plates**

14"D	<b>TSATPL14</b>	\$105
------	-----------------	-------

20"D	<b>TSATPL20</b>	\$105
------	-----------------	-------

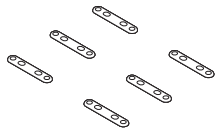

**Package of Six Tie Plates for Side-by-Side Worksurfaces**

7"L	<b>TSATTIE</b>	\$148
-----	----------------	-------

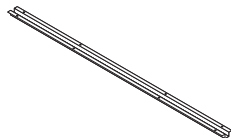

**Reinforcing Channels**

39"W	<b>TSATRC39</b>	\$ 74
------	-----------------	-------

48"W	<b>TSATRC48</b>	\$ 77
------	-----------------	-------

57"W	<b>TSATRC57</b>	\$ 81
------	-----------------	-------

72"W	<b>TSATRC72</b>	\$174
------	-----------------	-------



**For Canadian Pricing**  
Multiply U.S. Price by the  
Canadian price factor.  
► See page 1 for details.

# Worksurface-Height Power and Communication Access

## Worksurface-Mounted Power and Communication Sphere

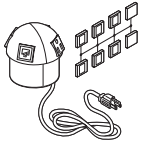

*Tip: Sphere is field installed. Use 3"-diameter drill to cut mounting hole at desired location.*

*Tip: Order jacks by calling any of the manufacturers listed below:*

- AMP Corporation  
1.800.522.6752
- Leviton  
1.800.722.2082
- Lucent  
1.800.344.0223
- Krone  
1.800.775.5766
- Punduit  
1.800.777.3300

Standard Includes	Required to Specify
<ul style="list-style-type: none"> <li>▶ Need help? Product details, page 52</li> </ul>	<ul style="list-style-type: none"> <li>• Sphere with two simplex electrical outlets: black plastic</li> <li>• Face plates to accommodate two customer-supplied voice/data jacks: black plastic</li> <li>• 6' power cord with three-prong plug: black plastic</li> </ul>
	Style number

Specification Information	
• Style Number	• U.S. Price
<b>PTDMGB3</b>	\$365

## Grommet Package



*Tip: Grommet requires a 3" diameter hole in the worksurface.*

Standard Includes	Required to Specify
<ul style="list-style-type: none"> <li>▶ Need help? Product details, page 52</li> </ul>	<ul style="list-style-type: none"> <li>• Package of 10 grommets: black plastic</li> </ul>
	Style number

Specification Information	
• Style Number	• U.S. Price
<b>TSAEGROM</b>	\$85



**For Canadian Pricing**  
Multiply U.S. Price by the Canadian price factor.  
▶ See page 1 for details.

## Worksurface-Mounted Receptacle Packages

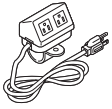

Standard Includes	Required to Specify
<ul style="list-style-type: none"> <li>▶ Need help? Product details, page 52</li> <li>• Package of three</li> <li>• Duplex receptacles: black plastic only</li> <li>• 9' cord with three-prong plug: black plastic only</li> </ul>	Style number

Specification Information	
• Style Number	• U.S. Price
<b>TSAERPW</b>	\$277
•	•

## Worksurface-Mounted Communication Module Packages

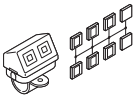

Standard Includes	Required to Specify
<ul style="list-style-type: none"> <li>▶ Need help? Product details, page 52</li> <li>• Package of three</li> <li>• Communication housing includes face plates to accommodate customer-supplied voice/data jacks: black plastic only</li> </ul>	Style number

Specification Information	
• Style Number	• U.S. Price
<b>TSAERDW</b>	\$177
•	•

*Tip: Many of the AMP, AT&T, Krone, Leviton, and other commercially available data terminals can be used—terminals must be of a design that will snap into 0.695 x 0.650, 0.590 x 0.790, or 0.590 x 0.750 openings, in 0.064 maximum thick face plates.*

*Tip: Order jacks by calling any of the manufacturers listed below:*

- AMP Corporation  
1.800.522.6752
- Leviton  
1.800.722.2082
- Lucent  
1.800.344.0223
- Krone  
1.800.775.5766
- Panduit  
1.800.777.3300



**For Canadian Pricing**  
Multiply U.S. Price by the Canadian price factor.  
▶ See page 1 for details.

**TS Series Worksurfaces**



---

# Specifying Universal Systems Worksurfaces

<b>Worksurfaces</b>	
Straight Worksurfaces	<b>220</b>
Parametric Straight Worksurfaces	<b>224</b>
Straight Worksurfaces with Soft Edge Profile	<b>228</b>
Parametric Straight Worksurfaces with Soft Edge Profile	<b>230</b>
120° Straight Worksurface	<b>234</b>
Transition Worksurfaces	<b>236</b>
Tapered Worksurfaces	<b>238</b>
Tapered Worksurfaces with Soft Edge Profile	<b>239</b>
Taper-Flat Worksurfaces	<b>240</b>
Single-Tapered Worksurfaces	<b>241</b>
Corner, Flat-Front Worksurfaces	<b>242</b>
Dual Corner, Flat-Front Worksurfaces	<b>243</b>
Corner, Straight-Front Worksurfaces	<b>244</b>
Corner, Curved-Front Worksurfaces	<b>245</b>
Extended Corner, Straight-Front Worksurfaces	<b>246</b>
Extended Corner, Curved-Front Worksurfaces	<b>248</b>
Corner, 120° Worksurfaces	<b>250</b>
Spanner Worksurfaces	<b>251</b>
Bullet Peninsula Worksurfaces	<b>252</b>
Angled Peninsula Worksurfaces	<b>253</b>
Jetty Worksurfaces	<b>254</b>
Bubble Jetty Worksurfaces	<b>256</b>
Visitor Worksurfaces	<b>258</b>
<b>Power and Data Access Door &amp; Tray</b>	<b>260</b>
<b>Worksurface Accessories</b>	<b>261</b>
<b>Panel-Mounted Universal Systems Worksurface Supports</b>	<b>262</b>
<b>Legs and Columns for Universal Systems Worksurfaces</b>	<b>266</b>
<b>Divisio Side Screen</b>	<b>269</b>

# Straight Worksurfaces

## High-Pressure Laminate or Wood Veneer

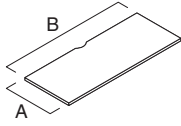

Tip: Supports for freestanding and panel-mounted applications must be specified separately.

Tip: Long work surface spans require additional support.  
 ▶ See understanding section for details, page 88

**For wood and laminate group 2 and 3 pricing,** please refer to the electronic catalog or SmartTools.

Tip: To specify 3 mm edge profile, no suffix is required. For all other edge profiles, add a suffix to the style number. (For example, US1830 becomes US1830SW for wood with square edge profile.)

Tip: Power and data access door and tray is ordered separately to be used with cutout.

▶ See page 260  
 ▶ See page 94 for work surface size availability matrix.

Tip: Scallop will be omitted if you select power access door.

Tip: Power access door option includes the power access door and a cutout for the door in the work surface.

Tip: Power access door option is only available on straight work surfaces with 1/2" cord drop.



**For Canadian Pricing**  
 Multiply U.S. Price by the Canadian price factor.  
 ▶ See page 1 for details.





Standard Includes	Required to Specify
<ul style="list-style-type: none"> <li>▶ Need help? Product details, page 86</li> <li>• Work surface: High-Pressure Laminate price group 1 or wood group 1 veneer</li> <li>• Laminate work surface:                             <ul style="list-style-type: none"> <li>–Plastic 3 mm edge or knife edge on front edge</li> <li>–Plastic default flat profile on side and back edges</li> </ul> </li> <li>• Wood work surface:                             <ul style="list-style-type: none"> <li>–Wood 3 mm edge profile on front edge</li> <li>–Matching veneer flat profile on side and back edges</li> </ul> </li> <li>• Cable scallop on back edge</li> </ul>	<ol style="list-style-type: none"> <li>1 Style number with appropriate edge profile suffix                             <ul style="list-style-type: none"> <li><b>K</b> Laminate with knife edge</li> <li><b>SW</b> Wood with square edge</li> </ul>                             ▶ See edge profiles below.                         </li> <li>2 High-Pressure Laminate or wood color number for work surface</li> <li>3 Plastic color number for front edge on laminate work surface, if selected</li> <li>4 Options, if selected (see below)                             <ul style="list-style-type: none"> <li>▶ See <i>Surface Materials</i>, page 360.</li> </ul> </li> </ol>

Surface Materials	Options	U.S. Price	Required to Specify
	<b>High-Pressure Laminate work surfaces</b>		
	<ul style="list-style-type: none"> <li>• Laminate price group 2</li> <li>• Laminate price group 3</li> <li>• Open Line laminate</li> </ul>	See information at left See information at left +\$102 plus cost of laminate	Specify laminate color number. Specify laminate color number. ▶ See <i>Surface Materials Reference Manual</i> .
	<b>Wood veneer work surfaces</b>		
	<ul style="list-style-type: none"> <li>• Wood group 2</li> <li>• Wood group 3</li> <li>• Customiz stain</li> </ul>	See information at left See information at left No cost	Specify wood color number. Specify wood color number. Specify with <i>Customiz stain</i> . ▶ See <i>Surface Materials Reference Manual</i> . Specify full-fill finish number.
	<ul style="list-style-type: none"> <li>• Full-fill finish on wood group 1</li> </ul>	Prices at right	
	<b>Doors</b>		
	<ul style="list-style-type: none"> <li>• Paint</li> <li>• Anodized aluminum</li> </ul>	No cost +\$ 12 per door	Specify paint color. Specify with <i>8043 Clear Anodized Aluminum</i> .
	<ul style="list-style-type: none"> <li>• Omit scallop</li> </ul>	No cost	Specify <i>omit scallop</i> .
	<b>Cutout for Power and Data Access Door and Tray</b>		
	• Cutout	No cost	Specify with <i>cutout for power and data access door</i> .
	<b>Power Access Door</b>		
	<b>Applies to 30"W</b>		
	<ul style="list-style-type: none"> <li>• No power access</li> <li>• Power access door center</li> </ul>	No cost +\$136	Specify with <i>no power access</i> . Specify with <i>power access door center</i> .
	<b>Applies to 36"W to 48"W</b>		
	<ul style="list-style-type: none"> <li>• No power access</li> <li>• Power access door center</li> <li>• Power access door left</li> <li>• Power access door right</li> </ul>	No cost +\$136 +\$136 +\$136	Specify with <i>no power access</i> . Specify with <i>power access door center</i> . Specify with <i>power access door left</i> . Specify with <i>power access door right</i> .
	<b>Applies to 54"W to 66"W</b>		
	<ul style="list-style-type: none"> <li>• No power access</li> <li>• Power access door center</li> <li>• Power access door left</li> <li>• Power access door right</li> <li>• Power access door left and right</li> </ul>	No cost +\$136 +\$136 +\$136 +\$272	Specify with <i>no power access</i> . Specify with <i>power access door center</i> . Specify with <i>power access door left</i> . Specify with <i>power access door right</i> . Specify with <i>power access door left and right</i> .
	<b>Applies to 72"W to 96"W</b>		
	<ul style="list-style-type: none"> <li>• No power access</li> <li>• Power access door center</li> <li>• Power access door left</li> <li>• Power access door right</li> <li>• Power access door left and right</li> <li>• Power access door left and center</li> <li>• Power access door right and center</li> <li>• Power access door left, right, and center</li> </ul>	No cost +\$136 +\$136 +\$136 +\$272 +\$272 +\$272 +\$408	Specify with <i>no power access</i> . Specify with <i>power access door center</i> . Specify with <i>power access door left</i> . Specify with <i>power access door right</i> . Specify with <i>power access door left and right</i> . Specify with <i>power access door left and center</i> . Specify with <i>power access door right and center</i> . Specify with <i>power access door left, right, and center</i> .

**Related Products**

- Panel-mounted Universal Systems worksurface supports ▶ Page 262
- Reinforcing channel ▶ Page 263
- Legs and supports for Universal Systems Worksurfaces ▶ Page 266

**Specification Information**





		U.S. Base Prices High-Pressure Laminate				Wood		U.S. Base Prices High-Pressure Laminate			
• Dimensions A B	• Style Number					• Option (Add \$ to Base Price)					
		• Plastic 3 mm Edge	• Plastic Knife Edge		• Wood Square Edge			• Plastic 3 mm Edge	• Plastic Knife Edge		
		No Suffix	Suffix K		Suffix SW	Full-Fill Finish on Wood Group 1		No Suffix	Suffix K		
<b>With 1/2" Cord Drop</b>											
18 3/8"	24"	<b>US1824</b>	\$254	\$ 373	N.A.	N.A.					
18 3/8"	30"	<b>US1830</b>	\$275	\$ 393	\$1000	+\$55					
18 3/8"	36"	<b>US1836</b>	\$295	\$ 414	\$1020	+\$56					
18 3/8"	42"	<b>US1842</b>	\$319	\$ 465	\$1164	+\$62					
18 3/8"	48"	<b>US1848</b>	\$385	\$ 531	\$1230	+\$63					
18 3/8"	54"	<b>US1854</b>	\$412	\$ 557	\$1257	+\$66					
18 3/8"	60"	<b>US1860</b>	\$444	\$ 621	\$1439	+\$73					
18 3/8"	66"	<b>US1866</b>	\$516	\$ 690	N.A.	N.A.					
18 3/8"	72"	<b>US1872</b>	\$576	\$ 750	N.A.	N.A.					
18 3/8"	78"	<b>US1878</b>	\$736	\$ 923	N.A.	N.A.					
18 3/8"	84"	<b>US1884</b>	\$776	\$ 962	N.A.	N.A.					
18 3/8"	90"	<b>US1890</b>	\$822	\$1008	N.A.	N.A.					
18 3/8"	96"	<b>US1896</b>	\$860	\$1047	N.A.	N.A.					
23 1/2"	24"	<b>US2424</b>	\$282	\$ 402	\$1007	+\$55					
23 1/2"	30"	<b>US2430</b>	\$305	\$ 423	\$1030	+\$55					
23 1/2"	36"	<b>US2436</b>	\$319	\$ 440	\$1044	+\$56					
23 1/2"	42"	<b>US2442</b>	\$346	\$ 491	\$1191	+\$62					
23 1/2"	48"	<b>US2448</b>	\$410	\$ 556	\$1255	+\$63					
23 1/2"	54"	<b>US2454</b>	\$440	\$ 582	\$1285	+\$66					
23 1/2"	60"	<b>US2460</b>	\$464	\$ 643	\$1459	+\$73					
23 1/2"	66"	<b>US2466</b>	\$521	\$ 701	\$1516	+\$75					
23 1/2"	72"	<b>US2472</b>	\$582	\$ 760	\$1577	+\$77					
23 1/2"	78"	<b>US2478</b>	\$780	\$ 967	N.A.	N.A.					
23 1/2"	84"	<b>US2484</b>	\$868	\$1051	N.A.	N.A.					
23 1/2"	90"	<b>US2490</b>	\$895	\$1081	N.A.	N.A.					
23 1/2"	96"	<b>US2496</b>	\$959	\$1142	N.A.	N.A.					
<b>With Full Depth</b>											
18 7/8"	24"	<b>WS1824</b>	\$254	\$ 375							
18 7/8"	30"	<b>WS1830</b>	\$275	\$ 396							
18 7/8"	36"	<b>WS1836</b>	\$295	\$ 416							
18 7/8"	42"	<b>WS1842</b>	\$319	\$ 467							
18 7/8"	48"	<b>WS1848</b>	\$385	\$ 533							
18 7/8"	54"	<b>WS1854</b>	\$412	\$ 560							
18 7/8"	60"	<b>WS1860</b>	\$444	\$ 624							
18 7/8"	66"	<b>WS1866</b>	\$516	\$ 696							
18 7/8"	72"	<b>WS1872</b>	\$576	\$ 756							
18 7/8"	78"	<b>WS1878</b>	\$736	\$ 932							
18 7/8"	84"	<b>WS1884</b>	\$776	\$ 972							
18 7/8"	90"	<b>WS1890</b>	\$822	\$1018							
18 7/8"	96"	<b>WS1896</b>	\$860	\$1056							
24"	24"	<b>WS2424</b>	\$282	\$ 403							
24"	30"	<b>WS2430</b>	\$305	\$ 426							
24"	36"	<b>WS2436</b>	\$319	\$ 440							
24"	42"	<b>WS2442</b>	\$346	\$ 494							
24"	48"	<b>WS2448</b>	\$410	\$ 558							
24"	54"	<b>WS2454</b>	\$440	\$ 588							
24"	60"	<b>WS2460</b>	\$464	\$ 644							
24"	66"	<b>WS2466</b>	\$521	\$ 701							
24"	72"	<b>WS2472</b>	\$582	\$ 762							
24"	78"	<b>WS2478</b>	\$780	\$ 976							
24"	84"	<b>WS2484</b>	\$868	\$1064							
24"	90"	<b>WS2490</b>	\$895	\$1091							
24"	96"	<b>WS2496</b>	\$959	\$1155							

▶ Specification Information, continued on next page

# Straight Worksurfaces High-Pressure Laminate or Wood Veneer, continued

► **Specification Information, continued from previous page**

## Specification Information

		U.S. Base Prices High-Pressure Laminate			Wood	U.S. Base Prices High-Pressure Laminate			
Dimensions A B	Style Number				Option (Add \$ to Base Price)	Dimensions A B	Style Number		
		Plastic 3 mm Edge	Plastic Knife Edge	Wood Square Edge				Plastic 3 mm Edge	Plastic Knife Edge
		No Suffix	Suffix K	Suffix SW	Full-Fill Finish on Wood Group 1			No Suffix	Suffix K

### With 1/2" Cord Drop

Dimensions A B	Style Number	Plastic 3 mm Edge	Plastic Knife Edge	Wood Square Edge	Option (Add \$ to Base Price)
29 1/2" 24"	<b>US3024</b>	\$399	\$517	\$1124	+\$55
29 1/2" 30"	<b>US3030</b>	\$414	\$532	\$1139	+\$56
29 1/2" 36"	<b>US3036</b>	\$444	\$560	\$1169	+\$59
29 1/2" 42"	<b>US3042</b>	\$464	\$608	\$1309	+\$63
29 1/2" 48"	<b>US3048</b>	\$528	\$675	\$1373	+\$66
29 1/2" 54"	<b>US3054</b>	\$568	\$710	\$1413	+\$69
29 1/2" 60"	<b>US3060</b>	\$603	\$778	\$1598	+\$75
29 1/2" 66"	<b>US3066</b>	\$655	\$831	\$1650	+\$77
29 1/2" 72"	<b>US3072</b>	\$717	\$891	\$1712	+\$78
35 1/2" 60"	<b>US3660</b>	\$655	N.A.	N.A.	N.A.
35 1/2" 66"	<b>US3666</b>	\$710	N.A.	N.A.	N.A.
35 1/2" 72"	<b>US3672</b>	\$770	N.A.	N.A.	N.A.

### With Full Depth

Dimensions A B	Style Number	Plastic 3 mm Edge	Plastic Knife Edge
30" 24"	<b>WS3024</b>	\$399	\$520
30" 30"	<b>WS3030</b>	\$414	\$535
30" 36"	<b>WS3036</b>	\$444	\$565
30" 42"	<b>WS3042</b>	\$464	\$612
30" 48"	<b>WS3048</b>	\$528	\$676
30" 54"	<b>WS3054</b>	\$568	\$716
30" 60"	<b>WS3060</b>	\$603	\$783
30" 66"	<b>WS3066</b>	\$655	\$835
30" 72"	<b>WS3072</b>	\$717	\$897

Tip: 35 1/2"D worksurfaces can only be used in freestanding applications.



### For Canadian Pricing

Multiply U.S. Price by the Canadian price factor.

► See page 1 for details.





► Options, continued from previous page

	Options	U.S. Price	Required to Specify
<b>Cord Drop</b>	• No cord drop	No cost	Specify <i>without cord drop</i> .
	• 1/2" cord drop	No cost	Specify <i>with 1/2" cord drop</i> .
<b>Scallop</b>	• Scallop	No cost	Specify <i>with scallop</i> .
	• Omit scallop	No cost	Specify <i>with no scallop</i> .
<b>Cutout for Power and Data Access Door and Tray</b>	<b>Applies to 48"W to 120"W</b>		
	• Cutout	No cost	Specify <i>with cutout for power and data access door</i> .
<b>Power Access Door</b>	<b>Applies to 30"W to 35<sup>15</sup>/<sub>16</sub>"W</b>		
	• No power access	No cost	Specify <i>with no power access</i> .
	• Power access door center	+\$136	Specify <i>with power access door center</i> .
	<b>Applies to 36"W to 51<sup>15</sup>/<sub>16</sub>"W</b>		
	• No power access	No cost	Specify <i>with no power access</i> .
	• Power access door center	+\$136	Specify <i>with power access door center</i> .
	• Power access door left	+\$136	Specify <i>with power access door left</i> .
	• Power access door right	+\$136	Specify <i>with power access door right</i> .
	<b>Applies to 52"W to 71<sup>15</sup>/<sub>16</sub>"W</b>		
	• No power access	No cost	Specify <i>with no power access</i> .
	• Power access door center	+\$136	Specify <i>with power access door center</i> .
	• Power access door left	+\$136	Specify <i>with power access door left</i> .
	• Power access door right	+\$136	Specify <i>with power access door right</i> .
	• Power access door left and right	+\$272	Specify <i>with power access door left and right</i> .
	<b>Applies to 72"W to 120"W</b>		
	• No power access	No cost	Specify <i>with no power access</i> .
	• Power access door center	+\$136	Specify <i>with power access door center</i> .
	• Power access door left	+\$136	Specify <i>with power access door left</i> .
	• Power access door right	+\$136	Specify <i>with power access door right</i> .
	• Power access door left and right	+\$272	Specify <i>with power access door left</i> .
	• Power access door left and center	+\$272	Specify <i>with power access door left and center</i> .
	• Power access door right and center	+\$272	Specify <i>with power access door right and center</i> .
	• Power access door left, right, and center	+\$408	Specify <i>with power access door left, right, and center</i> .
<b>Grommet Cutout</b>	• No grommet cutout	No cost	Specify <i>with no grommet cutout</i> .
	• 2 inch grommet cutout	No cost	Specify <i>with 2 inch grommet cutout</i> .
	• 3 inch grommet cutout	No cost	Specify <i>with 3 inch grommet cutout</i> .
<b>Grommet Location</b>	<b>Applies to 18"W to 24<sup>15</sup>/<sub>16</sub>"W</b>		
	• Center	No cost	Specify <i>with center grommet</i> .
	<b>Applies to 25"W to 33<sup>15</sup>/<sub>16</sub>"W</b>		
	• Center	No cost	Specify <i>with center grommet</i> .
	• Left	No cost	Specify <i>with left grommet</i> .
	• Right	No cost	Specify <i>with right grommet</i> .
	• Right and left	No cost	Specify <i>with right and left grommet</i> .
	<b>Applies to 34"W to 120"W</b>		
	• Center	No cost	Specify <i>with center grommet</i> .
	• Left	No cost	Specify <i>with left grommet</i> .
	• Right	No cost	Specify <i>with right grommet</i> .
	• Right and left	No cost	Specify <i>with right and left grommet</i> .
	• Left and center	No cost	Specify <i>with left and center grommet</i> .
	• Right and center	No cost	Specify <i>with right and center grommet</i> .
	• Right, left, and center	No cost	Specify <i>with right, left, and center grommet</i> .

Tip: When selecting with cord drop, subtract 1/2" from depth.

Tip: Scallop is available in the center location only. If cutout for power and data access door and tray or power access door is selected, scallop will default to omit scallop.

Tip: Power and data access door and tray is ordered separately to be used with cutout.

► Page 260

► See page 94 for worksurface size availability matrix.

Tip: Cutout for power and data access door and tray is available in the center location only. Worksurface depth must be greater than 24".

Tip: Power access door option is only available on straight worksurfaces with 1/2" cord drop.

Tip: Power access door option includes the power access door and a cutout for the door in the worksurface.

Tip: If cutout for power and data access door and tray or power access door is selected, grommet will default to no grommet.

► Options, continued on next page

  
**For Canadian Pricing**  
Multiply U.S. Price by the Canadian price factor.  
► See page 1 for details.

► Options, continued from previous page

**Related Products**

- Worksurface power and communication components ► Page 216
- Panel-mounted Universal Systems worksurface supports ► Page 262
- Reinforcing channel ► Page 263
- Legs and supports for Universal Systems Worksurfaces ► Page 266
- Divisio side screen ► Page 269
- 2½" round grommet ► Page 261
- 3" grommet package ► Page 261

**Specification Information**

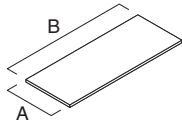

Tip: Dimension A = depth and dimension B = width.

Tip: Side and back edges of worksurface default to a flat profile.

Tip: Worksurfaces greater than 30"D can only be used in freestanding applications.

Style Number	Dimensions			U.S. Prices						
	Modular Depth	Parametric Depth	Parametric Width	18"W	24"W	30"W	36"W	42"W	48"W	
			Modular Width	18"W–23 <sup>15</sup> / <sub>16</sub> "W	24"W–29 <sup>15</sup> / <sub>16</sub> "W	30"W–35 <sup>15</sup> / <sub>16</sub> "W	36"W–41 <sup>15</sup> / <sub>16</sub> "W	42"W–47 <sup>15</sup> / <sub>16</sub> "W	48"W–53 <sup>15</sup> / <sub>16</sub> "W	

**3 mm Edge Profile—Laminate**

USWS	18 <sup>7</sup> / <sub>8</sub> "D	18"D – 23 <sup>7</sup> / <sub>16</sub> "D	\$ 234	\$ 254	\$ 275	\$ 295	\$ 319	\$ 385
	24"D	23 <sup>1</sup> / <sub>2</sub> "D – 29 <sup>7</sup> / <sub>16</sub> "D	\$ 265	\$ 282	\$ 305	\$ 319	\$ 346	\$ 410
	30"D	29 <sup>1</sup> / <sub>2</sub> "D – 35 <sup>7</sup> / <sub>16</sub> "D	\$ 380	\$ 399	\$ 414	\$ 444	\$ 464	\$ 528
	36"D	35 <sup>1</sup> / <sub>2</sub> "D – 36"D	\$ 455	\$ 473	\$ 494	\$ 514	\$ 538	\$ 603

**Knife Edge Profile—Laminate**

USWSK	18 <sup>7</sup> / <sub>8</sub> "D	18"D – 23 <sup>7</sup> / <sub>16</sub> "D	\$ 355	\$ 374	\$ 395	\$ 416	\$ 469	\$ 533
	24"D	23 <sup>1</sup> / <sub>2</sub> "D – 29 <sup>7</sup> / <sub>16</sub> "D	\$ 385	\$ 402	\$ 427	\$ 441	\$ 494	\$ 560
	30"D	29 <sup>1</sup> / <sub>2</sub> "D – 35 <sup>7</sup> / <sub>16</sub> "D	\$ 501	\$ 519	\$ 534	\$ 566	\$ 613	\$ 678
	36"D	35 <sup>1</sup> / <sub>2</sub> "D – 36"D	\$ 576	\$ 596	\$ 613	\$ 633	\$ 686	\$ 750

**Square Edge Profile—Wood**

USWSSW	18 <sup>7</sup> / <sub>8</sub> "D	18"D – 23 <sup>7</sup> / <sub>16</sub> "D	\$ 930	\$ 980	\$ 998	\$1021	\$1164	\$1230
	24"D	23 <sup>1</sup> / <sub>2</sub> "D – 29 <sup>7</sup> / <sub>16</sub> "D	\$ 959	\$1010	\$1028	\$1045	\$1189	\$1255
	30"D	29 <sup>1</sup> / <sub>2</sub> "D – 35 <sup>7</sup> / <sub>16</sub> "D	\$1073	\$1124	\$1137	\$1167	\$1311	\$1376
	36"D	35 <sup>1</sup> / <sub>2</sub> "D – 36"D	\$1297	\$1348	\$1365	\$1401	\$1571	\$1650

► Specification Information, continued on next page



**For Canadian Pricing**  
 Multiply U.S. Price by the Canadian price factor.  
 ► See page 1 for details.

► **Specification Information, continued from previous page**

: 54"W	: 60"W	: 66"W	: 72"W	: 78"W	: 84"W	: 90"W	: 96"W	: 102"W	: 108"W	: 114"W	: 120"W
: 54"W-	: 60"W-	: 66"W-	: 72"W-	: 78"W-	: 84"W-	: 90"W-	: 96"W-	: 102"W-	: 108"W-	: 114"W-	: 120"W
: 59 <sup>15</sup> / <sub>16</sub> "W	: 65 <sup>15</sup> / <sub>16</sub> "W	: 71 <sup>15</sup> / <sub>16</sub> "W	: 77 <sup>15</sup> / <sub>16</sub> "W	: 83 <sup>15</sup> / <sub>16</sub> "W	: 89 <sup>15</sup> / <sub>16</sub> "W	: 95 <sup>15</sup> / <sub>16</sub> "W	: 101 <sup>15</sup> / <sub>16</sub> "W	: 107 <sup>15</sup> / <sub>16</sub> "W	: 113 <sup>15</sup> / <sub>16</sub> "W	: 119 <sup>15</sup> / <sub>16</sub> "W	:

\$ 412	\$ 444	\$ 516	\$ 576	\$ 736	\$ 776	\$ 822	\$ 860	\$ 901	\$ 943	\$ 982	\$1021
\$ 440	\$ 464	\$ 521	\$ 582	\$ 780	\$ 868	\$ 895	\$ 959	\$1000	\$1045	\$1088	\$1129
\$ 568	\$ 603	\$ 655	\$ 717	\$ 925	\$ 966	\$1007	\$1046	\$1085	\$1126	\$1165	\$1208
\$ 632	\$ 655	\$ 710	\$ 770	\$ 966	\$1160	\$1208	\$1255	\$1303	\$1352	\$1398	\$1448
:	:	:	:	:	:	:	:	:	:	:	:

\$ 561	\$ 623	\$ 698	\$ 755	\$ 932	\$ 970	\$1016	\$1055	\$1109	\$1151	\$1189	\$1230
\$ 586	\$ 647	\$ 705	\$ 764	\$ 973	\$1058	\$1092	\$1154	\$1210	\$1252	\$1295	\$1340
\$ 715	\$ 786	\$ 837	\$ 899	\$1121	\$1161	\$1199	\$1240	\$1293	\$1334	\$1376	\$1414
\$ 782	\$ 837	\$ 888	\$ 953	\$1161	\$1353	\$1401	\$1451	\$1512	\$1561	\$1607	\$1655
:	:	:	:	:	:	:	:	:	:	:	:

\$1257	\$1439	\$1513	\$1571	\$1695	\$1908	\$1949	\$1995	\$2066	\$2105	\$2145	\$2217
\$1284	\$1463	\$1519	\$1578	\$1711	\$1940	\$2024	\$2057	\$2148	\$2193	\$2236	\$2309
\$1412	\$1600	\$1652	\$1713	\$1857	\$2096	\$2137	\$2176	\$2248	\$2289	\$2328	\$2400
\$1695	\$1919	\$1984	\$2060	\$2229	\$2515	\$2566	\$2613	\$2697	\$2746	\$2797	\$2881
:	:	:	:	:	:	:	:	:	:	:	:

 **For Canadian Pricing**  
Multiply U.S. Price by the  
Canadian price factor.  
► See page 1 for details.

# Straight Worksurfaces with Soft Edge Profile

High-Pressure Laminate or Wood Veneer

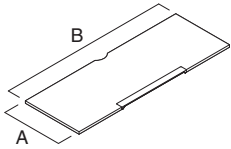

Tip: Supports for freestanding and panel-mounted applications must be specified separately.

Standard Includes	Required to Specify
<ul style="list-style-type: none"> <li>▶ Need help? Product details, page 86</li> <li>• Worksurface: High-Pressure Laminate price group 1</li> <li>• Laminate worksurface:                             <ul style="list-style-type: none"> <li>- Plastic antimicrobial soft edge profile centered on worksurface</li> <li>- Plastic 3 mm edge profile on balance of front edge</li> <li>- Plastic flat profile on side and back edges</li> </ul> </li> <li>• Wood group 1 worksurface:                             <ul style="list-style-type: none"> <li>- Wood 3 mm edge profile on front edge</li> <li>- Plastic soft edge centered on worksurface</li> <li>- Matching veneer flat profile on side and back edges</li> </ul> </li> <li>• Cable scallop on back edge</li> </ul>	<ol style="list-style-type: none"> <li>1 Style number with appropriate edge profile suffix                             <ul style="list-style-type: none"> <li>▶ <b>WS</b> Wood with square edge</li> <li>▶ See edge profiles below.</li> </ul> </li> <li>2 High-Pressure Laminate or wood color number for worksurface</li> <li>3 Plastic color number for front edge on laminate worksurface, if selected</li> <li>4 Options, if selected (see below)                             <ul style="list-style-type: none"> <li>▶ See <i>Surface Materials</i>, page 360.</li> </ul> </li> </ol>

**For wood and laminate group 2 and 3 pricing, please refer to the electronic catalog or SmartTools.**

Tip: Long worksurface spans require additional support. ▶ See understanding section for details, page 88

Tip: To specify 3 mm edge profile, no suffix is required. For all other edge profiles, add a suffix to the style number. (For example, US2448S becomes US2448SWS for wood with square edge profile.)

Tip: Power and data access door and tray is ordered separately to be used with cutout. ▶ See page 94 for worksurface size availability matrix.



Exception: 48"W worksurface with soft edge cannot have a post leg at the front edge.

Options	U.S. Price	Required to Specify
<b>Surface Materials</b> <ul style="list-style-type: none"> <li>• High-Pressure Laminate worksurfaces                             <ul style="list-style-type: none"> <li>• Laminate price group 2 See information at left</li> <li>• Laminate price group 3 See information at left</li> <li>• Open Line laminate +\$102 plus cost of laminate</li> </ul> </li> <li>• Wood veneer worksurfaces                             <ul style="list-style-type: none"> <li>• Wood group 2 See information at left</li> <li>• Wood group 3 See information at left</li> <li>• Customiz stain No cost</li> <li>• Full-fill finish on wood group 1 Prices at right</li> </ul> </li> </ul>		<ul style="list-style-type: none"> <li>Specify laminate color number.</li> <li>Specify laminate color number.</li> <li>▶ See <i>Surface Materials Reference Manual</i>.</li> <li>Specify wood color number.</li> <li>Specify wood color number.</li> <li>Specify <i>with Customiz stain</i>.</li> <li>▶ See <i>Surface Materials Reference Manual</i>.</li> <li>Specify full-fill finish number.</li> </ul>
<b>Soft Edge</b> <ul style="list-style-type: none"> <li>• Antimicrobial edge</li> <li>• No antimicrobial edge</li> </ul>	<ul style="list-style-type: none"> <li>No cost</li> <li>No cost</li> </ul>	<ul style="list-style-type: none"> <li>Specify <i>with antimicrobial soft edge</i>.</li> <li>Specify <i>without antimicrobial soft edge</i>.</li> </ul>
<b>Scallop</b> <ul style="list-style-type: none"> <li>• Omit scallop</li> </ul>	No cost	Specify omit scallop.
<b>Cutout for Power and Data Access Door and Tray</b> <ul style="list-style-type: none"> <li>• Cutout</li> </ul>	No cost	Specify <i>with cutout for power and data access door</i> .
<b>Related Products</b> <ul style="list-style-type: none"> <li>• Panel-mounted Universal Systems worksurface supports</li> <li>• Reinforcing channel</li> <li>• Legs and supports for Universal Systems Worksurfaces</li> </ul>		<ul style="list-style-type: none"> <li>▶ Page 262</li> <li>▶ Page 263</li> <li>▶ Page 266</li> </ul>



**For Canadian Pricing**  
Multiply U.S. Price by the Canadian price factor.  
▶ See page 1 for details.

**Specification Information**

			U.S. Base Prices			U.S. Base Price		
			High-Pressure Laminate	Wood		High-Pressure Laminate		
								
Dimensions	Style	Soft	Soft	Option	Dimensions	Style	Soft	
A B	Number	Edge Profile with Plastic 3 mm Edge	Edge Profile with Wood Square Edge	(Add \$ to Base Price)	A B	Number	Edge Profile with Plastic 3 mm Edge	
		No Suffix	Suffix WS	Full-Fill Finish on Wood Group 1			No Suffix	

**With 1/2" Cord Drop**

Dimensions A B	Style Number	High-Pressure Laminate	Wood	Option
23 1/2" 48"	<b>US2448S</b>	\$ 896	\$1741	+\$63
23 1/2" 54"	<b>US2454S</b>	\$ 926	\$1771	+\$66
23 1/2" 60"	<b>US2460S</b>	\$ 950	\$1945	+\$73
23 1/2" 66"	<b>US2466S</b>	\$1007	\$2002	+\$75
23 1/2" 72"	<b>US2472S</b>	\$1068	\$2063	+\$77
23 1/2" 78"	<b>US2478S</b>	\$1266	N.A.	N.A.
23 1/2" 84"	<b>US2484S</b>	\$1354	N.A.	N.A.
23 1/2" 90"	<b>US2490S</b>	\$1381	N.A.	N.A.
23 1/2" 96"	<b>US2496S</b>	\$1445	N.A.	N.A.
29 1/2" 48"	<b>US3048S</b>	\$1014	\$1859	+\$66
29 1/2" 54"	<b>US3054S</b>	\$1054	\$1899	+\$69
29 1/2" 60"	<b>US3060S</b>	\$1089	\$2084	+\$75
29 1/2" 66"	<b>US3066S</b>	\$1141	\$2136	+\$77
29 1/2" 72"	<b>US3072S</b>	\$1203	\$2198	+\$78

**With Full Depth**

Dimensions A B	Style Number	High-Pressure Laminate
24" 48"	<b>WS2448S</b>	\$ 896
24" 54"	<b>WS2454S</b>	\$ 926
24" 60"	<b>WS2460S</b>	\$ 950
24" 66"	<b>WS2466S</b>	\$1007
24" 72"	<b>WS2472S</b>	\$1068
24" 78"	<b>WS2478S</b>	\$1266
24" 84"	<b>WS2484S</b>	\$1354
24" 90"	<b>WS2490S</b>	\$1381
24" 96"	<b>WS2496S</b>	\$1445
30" 48"	<b>WS3048S</b>	\$1014
30" 54"	<b>WS3054S</b>	\$1054
30" 60"	<b>WS3060S</b>	\$1089
30" 66"	<b>WS3066S</b>	\$1141
30" 72"	<b>WS3072S</b>	\$1203

  
**For Canadian Pricing**  
Multiply U.S. Price by the  
Canadian price factor.  
▶ See page 1 for details.

# Parametric Straight Worksurfaces with Soft Edge Profile

High-Pressure Laminate or Wood Veneer

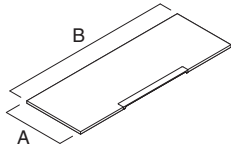

▶ Need help?  
Product details,  
page 94

## Standard Includes

- Worksurface: High-Pressure Laminate price group 1 or wood group 1 veneer
- Laminate worksurface:
  - Plastic antimicrobial soft edge profile centered on worksurface
  - Plastic 3 mm edge profile or knife edge profile on front edge
  - Plastic default flat profile on side and back edges
- Wood worksurface:
  - Plastic antimicrobial soft edge centered on worksurface
  - Wood square edge profile on front edge
  - Matching veneer flat profile on side and back edges
- Depth: 18"D – 36"D
- Width: 18"W – 120"W

## Required to Specify

- 1 Style number
  - 2 Worksurface size type (see below under Required Selections)
  - 3 Depth (see below under Required Selections)
  - 4 Width (see below under Required Selections)
  - 5 User edge profile (see below)
  - 6 High-Pressure Laminate or wood color number for worksurface
  - 7 Plastic color number for front edge on laminate worksurface, if selected
  - 8 Options, if selected (see below)
- ▶ See *Surface Materials*, page 360.

Tip: Long worksurface spans require additional support.  
▶ See understanding section for details, page 90

	Required Selections	U.S. Price	Required to Specify
--	---------------------	------------	---------------------

<b>Worksurface Size Type</b>	<ul style="list-style-type: none"> <li>• Modular</li> <li>• Parametric</li> </ul>	No cost No cost	Specify <i>with modular</i> . Specify <i>with parametric</i> .																												
<b>Depth</b>	<table border="1"> <thead> <tr> <th>Modular</th> <th>Parametric</th> </tr> </thead> <tbody> <tr> <td>• 18<sup>7</sup>/<sub>8</sub>"D</td> <td>18"D–23<sup>7</sup>/<sub>16</sub>"D</td> </tr> <tr> <td>• 24"D</td> <td>23<sup>1</sup>/<sub>2</sub>"D–29<sup>7</sup>/<sub>16</sub>"D</td> </tr> <tr> <td>• 30"D</td> <td>29<sup>1</sup>/<sub>2</sub>"D–35<sup>7</sup>/<sub>16</sub>"D</td> </tr> <tr> <td>• 36"D</td> <td>35<sup>1</sup>/<sub>2</sub>"D–36"D</td> </tr> </tbody> </table>	Modular	Parametric	• 18 <sup>7</sup> / <sub>8</sub> "D	18"D–23 <sup>7</sup> / <sub>16</sub> "D	• 24"D	23 <sup>1</sup> / <sub>2</sub> "D–29 <sup>7</sup> / <sub>16</sub> "D	• 30"D	29 <sup>1</sup> / <sub>2</sub> "D–35 <sup>7</sup> / <sub>16</sub> "D	• 36"D	35 <sup>1</sup> / <sub>2</sub> "D–36"D	Prices at right Prices at right Prices at right Prices at right	Specify depth. Specify depth. Specify depth. Specify depth.																		
Modular	Parametric																														
• 18 <sup>7</sup> / <sub>8</sub> "D	18"D–23 <sup>7</sup> / <sub>16</sub> "D																														
• 24"D	23 <sup>1</sup> / <sub>2</sub> "D–29 <sup>7</sup> / <sub>16</sub> "D																														
• 30"D	29 <sup>1</sup> / <sub>2</sub> "D–35 <sup>7</sup> / <sub>16</sub> "D																														
• 36"D	35 <sup>1</sup> / <sub>2</sub> "D–36"D																														
<b>Width</b>	<table border="1"> <thead> <tr> <th>Modular</th> <th>Parametric</th> </tr> </thead> <tbody> <tr> <td>• 48"W</td> <td>48"W–53<sup>15</sup>/<sub>16</sub>"W</td> </tr> <tr> <td>• 54"W</td> <td>54"W–59<sup>15</sup>/<sub>16</sub>"W</td> </tr> <tr> <td>• 60"W</td> <td>60"W–65<sup>15</sup>/<sub>16</sub>"W</td> </tr> <tr> <td>• 66"W</td> <td>66"W–71<sup>15</sup>/<sub>16</sub>"W</td> </tr> <tr> <td>• 72"W</td> <td>72"W–77<sup>15</sup>/<sub>16</sub>"W</td> </tr> <tr> <td>• 78"W</td> <td>78"W–83<sup>15</sup>/<sub>16</sub>"W</td> </tr> <tr> <td>• 84"W</td> <td>84"W–89<sup>15</sup>/<sub>16</sub>"W</td> </tr> <tr> <td>• 90"W</td> <td>90"W–95<sup>15</sup>/<sub>16</sub>"W</td> </tr> <tr> <td>• 96"W</td> <td>96"W–101<sup>15</sup>/<sub>16</sub>"W</td> </tr> <tr> <td>• 102"W</td> <td>102"W–107<sup>15</sup>/<sub>16</sub>"W</td> </tr> <tr> <td>• 108"W</td> <td>108"W–113<sup>15</sup>/<sub>16</sub>"W</td> </tr> <tr> <td>• 114"W</td> <td>114"W–119<sup>15</sup>/<sub>16</sub>"W</td> </tr> <tr> <td>• 120"W</td> <td>120"W</td> </tr> </tbody> </table>	Modular	Parametric	• 48"W	48"W–53 <sup>15</sup> / <sub>16</sub> "W	• 54"W	54"W–59 <sup>15</sup> / <sub>16</sub> "W	• 60"W	60"W–65 <sup>15</sup> / <sub>16</sub> "W	• 66"W	66"W–71 <sup>15</sup> / <sub>16</sub> "W	• 72"W	72"W–77 <sup>15</sup> / <sub>16</sub> "W	• 78"W	78"W–83 <sup>15</sup> / <sub>16</sub> "W	• 84"W	84"W–89 <sup>15</sup> / <sub>16</sub> "W	• 90"W	90"W–95 <sup>15</sup> / <sub>16</sub> "W	• 96"W	96"W–101 <sup>15</sup> / <sub>16</sub> "W	• 102"W	102"W–107 <sup>15</sup> / <sub>16</sub> "W	• 108"W	108"W–113 <sup>15</sup> / <sub>16</sub> "W	• 114"W	114"W–119 <sup>15</sup> / <sub>16</sub> "W	• 120"W	120"W	Prices at right Prices at right Prices at right Prices at right Prices at right Prices at right Prices at right Prices at right Prices at right Prices at right Prices at right Prices at right Prices at right Prices at right	Specify width. Specify width. Specify width. Specify width. Specify width. Specify width. Specify width. Specify width. Specify width. Specify width. Specify width. Specify width. Specify width. Specify width.
Modular	Parametric																														
• 48"W	48"W–53 <sup>15</sup> / <sub>16</sub> "W																														
• 54"W	54"W–59 <sup>15</sup> / <sub>16</sub> "W																														
• 60"W	60"W–65 <sup>15</sup> / <sub>16</sub> "W																														
• 66"W	66"W–71 <sup>15</sup> / <sub>16</sub> "W																														
• 72"W	72"W–77 <sup>15</sup> / <sub>16</sub> "W																														
• 78"W	78"W–83 <sup>15</sup> / <sub>16</sub> "W																														
• 84"W	84"W–89 <sup>15</sup> / <sub>16</sub> "W																														
• 90"W	90"W–95 <sup>15</sup> / <sub>16</sub> "W																														
• 96"W	96"W–101 <sup>15</sup> / <sub>16</sub> "W																														
• 102"W	102"W–107 <sup>15</sup> / <sub>16</sub> "W																														
• 108"W	108"W–113 <sup>15</sup> / <sub>16</sub> "W																														
• 114"W	114"W–119 <sup>15</sup> / <sub>16</sub> "W																														
• 120"W	120"W																														

	Options	U.S. Price	Required to Specify
--	---------	------------	---------------------

<b>Surface Materials</b>	<b>High-Pressure Laminate worksurfaces</b>		
	<ul style="list-style-type: none"> <li>• Laminate price group 2</li> <li>• Laminate price group 3</li> <li>• Open Line laminate</li> </ul>	See information at left See information at left +\$102 plus cost of laminate	Specify laminate color number. Specify laminate color number. ▶ See <i>Surface Materials Reference Manual</i> .
	<b>Wood veneer worksurfaces</b>		
	<ul style="list-style-type: none"> <li>• Wood group 2</li> <li>• Wood group 3</li> <li>• Customiz stain</li> </ul>	See information at left See information at left No cost	Specify wood color number. Specify wood color number. Specify <i>with Customiz stain</i> . ▶ See <i>Surface Materials Reference Manual</i> .
	<ul style="list-style-type: none"> <li>• Full-fill finish on wood group 1</li> </ul>	Prices at right	Specify full-fill finish number.
	<b>Wood grain direction</b>		
	<ul style="list-style-type: none"> <li>• No direction</li> <li>• Long grain</li> <li>• Short grain</li> </ul>	No cost No cost No cost	Specify <i>with no direction</i> . Specify <i>with long grain direction</i> . Specify <i>with short grain direction</i> .
	<b>Door</b>		
	<ul style="list-style-type: none"> <li>• Paint</li> <li>• Anodized aluminum</li> </ul>	No cost +\$ 12	Specify paint color number. Specify <i>with 8043 Clear Anodized Aluminum</i> .

For wood and laminate group 2 and 3 pricing, please refer to the electronic catalog or SmartTools.

Tip: Short grain laminate is only available on surfaces 60"W or less.

Tip: Soft edge is available with or without 1/2" cord drop.

<b>Soft Edge</b>	<ul style="list-style-type: none"> <li>• Antimicrobial edge</li> <li>• No antimicrobial edge</li> </ul>	No cost No cost	Specify <i>with antimicrobial edge</i> . Specify <i>without antimicrobial edge</i> .
------------------	---	--------------------	---

▶ Options, continued on next page

► Options, continued from previous page

	Options	U.S. Price	Required to Specify
<b>Cord Drop</b>	• No cord drop	No cost	Specify <i>without cord drop</i> . Specify with <i>1/2" cord drop</i> .
	• 1/2" cord drop	No cost	
<b>Scallop</b>	• Scallop	No cost	Specify with <i>scallop</i> . Specify with <i>no scallop</i> .
	• Omit scallop	No cost	
<b>Cutout for Power and Data Access Door and Tray</b>	<b>Applies to 48"W to 120"W</b> • Cutout	No cost	Specify with <i>cutout for power and data access door</i> .
<b>Power Access Door</b>	<b>Applies to 48"W to 51<sup>15</sup>/<sub>16</sub>"W</b>		
	• No power access	No cost	Specify with <i>no power access</i> .
	• Power access door center	+\$136	Specify with <i>power access door center</i> .
	• Power access door left	+\$136	Specify with <i>power access door left</i> .
• Power access door right	+\$136	Specify with <i>power access door right</i> .	
<b>Applies to 52"W to 71<sup>15</sup>/<sub>16</sub>"W</b>	• No power access	No cost	Specify with <i>no power access</i> .
	• Power access door center	+\$136	Specify with <i>power access door center</i> .
	• Power access door left	+\$136	Specify with <i>power access door left</i> .
	• Power access door right	+\$136	Specify with <i>power access door right</i> .
	• Power access door left and right	+\$272	Specify with <i>power access door left and right</i> .
	• Power access door left and center	+\$272	Specify with <i>power access door left and center</i> .
<b>Applies to 72"W to 120"W</b>	• No power access	No cost	Specify with <i>no power access</i> .
	• Power access door center	+\$136	Specify with <i>power access door center</i> .
	• Power access door left	+\$136	Specify with <i>power access door left</i> .
	• Power access door right	+\$136	Specify with <i>power access door right</i> .
• Power access door left and right	+\$272	Specify with <i>power access door left and right</i> .	
• Power access door left and center	+\$272	Specify with <i>power access door left and center</i> .	
• Power access door right and center	+\$272	Specify with <i>power access door right and center</i> .	
• Power access door left, right, and center	+\$408	Specify with <i>power access door left, right, and center</i> .	
<b>Grommet Cutout</b>	• No grommet cutout	No cost	Specify with <i>no grommet cutout</i> .
	• 2" grommet cutout	No cost	Specify with <i>2" grommet cutout</i> .
	• 3" grommet cutout	No cost	Specify with <i>3" grommet cutout</i> .
<b>Grommet Location</b>	<b>Applies to 48"W to 120"W</b>		
	• Center	No cost	Specify with <i>center grommet</i> .
	• Left	No cost	Specify with <i>left grommet</i> .
	• Right	No cost	Specify with <i>right grommet</i> .
	• Right and left	No cost	Specify with <i>right and left grommet</i> .
	• Left and center	No cost	Specify with <i>left and center grommet</i> .
	• Right and center	No cost	Specify with <i>right and center grommet</i> .
• Right, left, and center	No cost	Specify with <i>right, left, and center grommet</i> .	
<b>Related Products</b>	• Worksurface power and communication components		► Page 216
	• Panel-mounted Universal Systems worksurface supports		► Page 262
	• Reinforcing channel		► Page 263
	• Legs and supports for Universal Systems Worksurfaces		► Page 266
	• Divisio side screen		► Page 269
	• 2 1/2" round grommet		► Page 261
	• 3" grommet package		► Page 261

► Specification Information, on next page

Tip: When selecting with cord drop, subtract 1/2" from depth.

Tip: Scallop is available in the center location only. If cutout for power and data access door and tray or power access door is selected, scallop will default to omit scallop.

Tip: Power and data access door and tray is ordered separately to be used with cutout.

► Page 260

► See page 94 for worksurface size availability matrix.

Tip: Cutout for power and data access door and tray is available in the center location only. Worksurface depth must be greater than 24".

Tip: Power access door option is only available on straight worksurfaces with 1/2" cord drop.

Tip: Power access door option includes the power access door and a cutout for the door in the worksurface.

Tip: If cutout for power and data access door and tray or power access door is selected, grommet will default to no grommet.



**For Canadian Pricing**

Multiply U.S. Price by the Canadian price factor.

► See page 1 for details.

► Options, on previous page

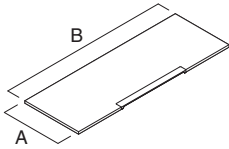

Tip: Dimension A = depth and dimension B = width.

Tip: Side and back edges of worksurface default to a flat profile.

Tip: Worksurfaces greater than 30"D can only be used in freestanding applications.

**Specification Information**

Style Number	Dimensions		Modular Width	U.S. Prices				
	Modular Depth	Parametric Depth		48"W	54"W	60"W	66"W	72"W
			Parametric Width	48"W–53 <sup>15</sup> / <sub>16</sub> "W	54"W–59 <sup>15</sup> / <sub>16</sub> "W	60"W–65 <sup>15</sup> / <sub>16</sub> "W	66"W–71 <sup>15</sup> / <sub>16</sub> "W	72"W–77 <sup>15</sup> / <sub>16</sub> "W

**3 mm Edge Profile—Laminate**

uswss	18 <sup>7</sup> / <sub>8</sub> "D	18"D – 23 <sup>7</sup> / <sub>16</sub> "D	\$ 871	\$ 895	\$ 928	\$ 998	\$1058
	24"D	23 <sup>1</sup> / <sub>2</sub> "D – 29 <sup>7</sup> / <sub>16</sub> "D	\$ 892	\$ 923	\$ 950	\$1008	\$1067
	30"D	29 <sup>1</sup> / <sub>2</sub> "D – 35 <sup>7</sup> / <sub>16</sub> "D	\$1014	\$1051	\$1088	\$1137	\$1202
	36"D	35 <sup>1</sup> / <sub>2</sub> "D – 36"D	\$1159	\$1187	\$1218	\$1273	\$1334

**Square Edge Profile—Wood**

uswssws	18 <sup>7</sup> / <sub>8</sub> "D	18"D – 23 <sup>7</sup> / <sub>16</sub> "D	\$1713	\$1739	\$1924	\$1999	\$2057
	24"D	23 <sup>1</sup> / <sub>2</sub> "D – 29 <sup>7</sup> / <sub>16</sub> "D	\$1737	\$1768	\$1946	\$2005	\$2064
	30"D	29 <sup>1</sup> / <sub>2</sub> "D – 35 <sup>7</sup> / <sub>16</sub> "D	\$1858	\$1897	\$2085	\$2137	\$2200
	36"D	35 <sup>1</sup> / <sub>2</sub> "D – 36"D	\$2133	\$2177	\$2403	\$2466	\$2542

► Specification Information, continued on next page



**For Canadian Pricing**

Multiply U.S. Price by the Canadian price factor.

► See page 1 for details.

► **Specification Information, continued from previous page**

78"W	84"W	90"W	96"W	102"W	108"W	114"W	120"W
78"W-	84"W-	90"W-	96"W-	102"W-	108"W-	114"W-	120"W
83 <sup>15</sup> / <sub>16</sub> "W	89 <sup>15</sup> / <sub>16</sub> "W	95 <sup>15</sup> / <sub>16</sub> "W	101 <sup>15</sup> / <sub>16</sub> "W	107 <sup>15</sup> / <sub>16</sub> "W	113 <sup>15</sup> / <sub>16</sub> "W	119 <sup>15</sup> / <sub>16</sub> "W	
\$1220	\$1260	\$1307	\$1345	\$1388	\$1426	\$1466	\$1504
\$1264	\$1348	\$1381	\$1442	\$1486	\$1529	\$1571	\$1616
\$1410	\$1451	\$1490	\$1530	\$1570	\$1611	\$1651	\$1693
\$1451	\$1644	\$1693	\$1737	\$1788	\$1837	\$1886	\$1931
\$2177	\$2391	\$2435	\$2478	\$2550	\$2588	\$2630	\$2699
\$2197	\$2425	\$2510	\$2540	\$2633	\$2676	\$2722	\$2797
\$2341	\$2580	\$2619	\$2663	\$2733	\$2773	\$2811	\$2884
\$2715	\$3000	\$3049	\$3096	\$3182	\$3229	\$3279	\$3363

 **For Canadian Pricing**  
Multiply U.S. Price by the  
Canadian price factor.  
► See page 1 for details.

# 120° Straight Worksurfaces

High-Pressure Laminate or Wood Veneer

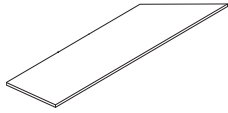

Tip: Supports for freestanding panel-mounted applications must be specified separately.

Standard Includes	Required to Specify
<ul style="list-style-type: none"> <li>▶ Need help? Product details, page 86</li> <li>• Worksurface: High-Pressure Laminate price group 1 or wood group 1 veneer</li> <li>• Laminate worksurface:                             <ul style="list-style-type: none"> <li>–Plastic 3 mm edge profile, or plastic knife profile on front edge</li> <li>–Plastic default flat profile on side and back edges</li> </ul> </li> <li>• Wood worksurface:                             <ul style="list-style-type: none"> <li>–Wood 3 mm edge profile on front edge</li> <li>–Matching veneer flat profile on side and back edges</li> </ul> </li> <li>• Cable scallop on back edge</li> </ul>	<ol style="list-style-type: none"> <li>1 Style number with appropriate edge profile suffix                             <ul style="list-style-type: none"> <li><b>K</b> Laminate with knife edge</li> <li><b>SW</b> Wood with square edge</li> </ul>                             ▶ See edge profiles at right.                         </li> <li>2 High-Pressure Laminate or wood color number for worksurface</li> <li>3 Plastic color number for front edge on laminate worksurface, if selected</li> <li>4 Options, if selected (see below)                             <ul style="list-style-type: none"> <li>▶ See <i>Surface Materials</i>, page 360.</li> </ul> </li> </ol>

**For wood and laminate group 2 and 3 pricing,** please refer to the electronic catalog or *SmartTools*.

Tip: Long worksurface spans require additional support. ▶ See understanding section for details, page 88

Tip: To specify 3 mm edge profile, no suffix is required. For all other edge profiles, add a suffix to the style number. (For example, USE2448LH becomes USE2448LHSW for wood with square edge profile.)

Tip: Power and data access door and tray is ordered separately to be used with cutout. ▶ See page 260

▶ See page 94 for worksurface size availability matrix.

Tip: When facing the user edge, the side the diagonal on is the handed side.

Tip: Power access door option includes the power access door and a cutout for the door in the worksurface.

Surface Materials	Options	U.S. Price	Required to Specify
	<b>High-Pressure Laminate worksurfaces</b>		
	<ul style="list-style-type: none"> <li>• Laminate price group 2</li> <li>• Laminate price group 3</li> <li>• Open Line laminate</li> </ul>	See information at left See information at left +\$102 plus cost of laminate	Specify laminate color number. Specify laminate color number. ▶ See <i>Surface Materials Reference Manual</i> .
	<b>Wood veneer worksurfaces</b>		
	<ul style="list-style-type: none"> <li>• Wood group 2</li> <li>• Wood group 3</li> <li>• Customiz stain</li> </ul>	See information at left See information at left No cost	Specify wood color number. Specify wood color number. Specify with <i>Customiz stain</i> . ▶ See <i>Surface Materials Reference Manual</i> .
	<ul style="list-style-type: none"> <li>• Full-fill finish on wood group 1</li> </ul>	Prices at right	Specify full-fill finish number.
	<b>Doors</b>		
	<ul style="list-style-type: none"> <li>• Paint</li> <li>• Anodized aluminum</li> </ul>	No cost +\$ 12 per door	Specify paint color. Specify with <i>8043 Clear Anodized Aluminum</i> .
<b>Scallop</b>	<ul style="list-style-type: none"> <li>• Omit scallop</li> </ul>	No cost	Specify <i>omit scallop</i> .
<b>Power Access Door</b>	<b>Applies to 48"W</b>		
	<ul style="list-style-type: none"> <li>• No power access</li> <li>• Power access door center</li> <li>• Power access door left</li> <li>• Power access door right</li> </ul>	No cost +\$136 +\$136 +\$136	Specify with <i>no power access</i> . Specify with <i>power access door center</i> . Specify with <i>power access door left</i> . Specify with <i>power access door left</i> .
	<b>Applies to 60"W</b>		
	<ul style="list-style-type: none"> <li>• No power access</li> <li>• Power access door center</li> <li>• Power access door left</li> <li>• Power access door right</li> <li>• Power access door left and right</li> </ul>	No cost +\$136 +\$136 +\$136 +\$272	Specify with <i>no power access</i> . Specify with <i>power access door center</i> . Specify with <i>power access door left</i> . Specify with <i>power access door right</i> . Specify with <i>power access door left and right</i> .
	<b>Applies to 72"W</b>		
	<ul style="list-style-type: none"> <li>• No power access</li> <li>• Power access door center</li> <li>• Power access door left</li> <li>• Power access door right</li> <li>• Power access door left and right</li> <li>• Power access door left and center</li> <li>• Power access door right and center</li> <li>• Power access door left, right, and center</li> </ul>	No cost +\$136 +\$136 +\$136 +\$272 +\$272 +\$272 +\$408	Specify with <i>no power access</i> . Specify with <i>power access door center</i> . Specify with <i>power door left</i> . Specify with <i>power door right</i> . Specify with <i>power access door left and and right</i> . Specify with <i>power access door left and center</i> . Specify with <i>power access door right and center</i> . Specify with <i>power access door left, right, and center</i> .



**Related Products**

- Wiring and cabling
- Reinforcing channel
- Legs and supports for Universal Systems Worksurfaces

- ▶ Page 196
- ▶ Page 263
- ▶ Page 266

 **For Canadian Pricing**  
 Multiply U.S. Price by the Canadian price factor.  
 ▶ See page 1 for details.

**Specification Information**

• Dimensions A B C D				• Style Number	U.S. Base Prices			• Option (Add \$ to Base Price)
					High-Pressure Laminate	Wood		
								
					• Plastic 3 mm Edge	• Plastic Knife Edge	• Wood Square Edge	
					No Suffix	Suffix K	Suffix SW	• Full-Fill Finish on Wood Group 1

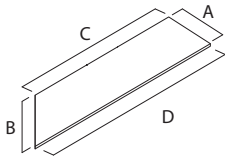

**Left-Hand With 1/2" Cord Drop**

23 1/2"	27 1/8"	48"	61 1/16"	<b>USE2448LH</b>	\$403	\$556	\$1267	+\$63
23 1/2"	27 1/8"	60"	73 9/16"	<b>USE2460LH</b>	\$458	\$643	\$1474	+\$73
23 1/2"	27 1/8"	72"	85 9/16"	<b>USE2472LH</b>	\$574	\$760	\$1590	+\$77
29 1/2"	34 1/16"	48"	65 1/16"	<b>USE3048LH</b>	\$520	\$675	\$1383	+\$66
29 1/2"	34 1/16"	60"	77 1/16"	<b>USE3060LH</b>	\$596	\$778	\$1611	+\$75
29 1/2"	34 1/16"	72"	89 1/16"	<b>USE3072LH</b>	\$709	\$891	\$1725	+\$78

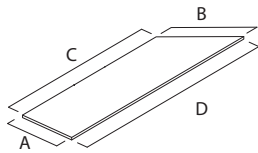

**Right-Hand With 1/2" Cord Drop**

23 1/2"	27 1/8"	48"	61 1/16"	<b>USE2448RH</b>	\$403	\$556	\$1267	+\$63
23 1/2"	27 1/8"	60"	73 9/16"	<b>USE2460RH</b>	\$458	\$643	\$1474	+\$73
23 1/2"	27 1/8"	72"	85 9/16"	<b>USE2472RH</b>	\$574	\$760	\$1590	+\$77
29 1/2"	34 1/16"	48"	65 1/16"	<b>USE3048RH</b>	\$520	\$675	\$1383	+\$66
29 1/2"	34 1/16"	60"	77 1/16"	<b>USE3060RH</b>	\$596	\$778	\$1611	+\$75
29 1/2"	34 1/16"	72"	89 1/16"	<b>USE3072RH</b>	\$709	\$891	\$1725	+\$78



**For Canadian Pricing**  
 Multiply U.S. Price by the  
 Canadian price factor.  
 ▶ See page 1 for details.

# Transition Worksurfaces

## High-Pressure Laminate or Wood Veneer

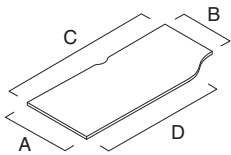

Tip: Illustration above shows a left-hand worksurface.

Tip: Supports for freestanding and panel-mounted applications must be specified separately.

**For wood and laminate group 2 and 3 pricing, please refer to the electronic catalog or SmartTools.**

Tip: Long worksurface spans require additional support. ▶ See understanding section for details, page 88

Tip: To specify 3 mm edge profile, no suffix is required. For all other edge profiles, add a suffix to the style number. (For example, UT2136L becomes UT2136L.SW for wood with square edge profile.)



Standard Includes		Required to Specify
▶ Need help? Product details, page 86	<ul style="list-style-type: none"> <li>• Worksurface: High-Pressure Laminate price group 1 or wood group 1 veneer</li> <li>• Laminate worksurface:               <ul style="list-style-type: none"> <li>–Plastic 3 mm edge profile or plastic knife profile on front edge</li> <li>–Plastic default flat profile on side and back edges</li> </ul> </li> <li>• Wood worksurface:               <ul style="list-style-type: none"> <li>–Wood 3 mm edge profile on front edge</li> <li>–Matching veneer flat profile on side and back edges</li> </ul> </li> <li>• Cable scallop on back edge</li> <li>• Wire manager for wood veneer worksurfaces, if selected: black</li> </ul>	1 Style number with appropriate edge profile suffix <b>K</b> Laminate with knife edge <b>SW</b> Wood with square edge ▶ See edge profiles at right. 2 High-Pressure Laminate or wood color number for worksurface 3 Plastic color number for front edge on laminate worksurface, if selected 4 Options, if selected (see below) ▶ See <i>Surface Materials</i> , page 360.

	Options	U.S. Price	Required to Specify
<b>Surface Materials</b>	<b>High-Pressure Laminate worksurfaces</b>		
	<ul style="list-style-type: none"> <li>• Laminate price group 2</li> <li>• Laminate price group 3</li> <li>• Open Line laminate</li> </ul>	See information at left See information at left +\$102 plus cost of laminate	Specify laminate color number. Specify laminate color number. ▶ See <i>Surface Materials Reference Manual</i> .
	<b>Wood veneer worksurfaces</b>		
	<ul style="list-style-type: none"> <li>• Wood group 2</li> <li>• Wood group 3</li> <li>• Customiz stain</li> </ul>	See information at left See information at left No cost	Specify wood color number. Specify wood color number. Specify <i>with Customiz stain</i> . ▶ See <i>Surface Materials Reference Manual</i> . Specify full-fill finish number.
<b>Scallop</b>	<ul style="list-style-type: none"> <li>• Omit scallop</li> </ul>	No cost	Specify <i>omit scallop</i> .
<b>Related Products</b>	<ul style="list-style-type: none"> <li>• Panel-mounted Universal Systems worksurface supports</li> <li>• Legs and supports for Universal Systems Worksurfaces</li> </ul>		▶ Page 262 ▶ Page 266



**For Canadian Pricing**  
 Multiply U.S. Price by the Canadian price factor.  
 ▶ See page 1 for details.

**Specification Information**

				U.S. Base Prices			U.S. Base Price		
				High-Pressure Laminate	Wood	High-Pressure Laminate			
									
• Dimensions	• Style	• Plastic	• Wood	• Option	• Plastic				
A B C D	Number	3 mm	Square	(Add \$ to	A B C D	Number	3 mm	Edge	
		Edge	Edge	Base Price)			Edge		
		No Suffix	Suffix SW	Full-Fill					
				Finish					
				Wood Group 1					

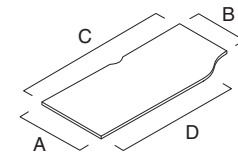
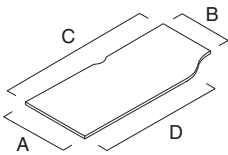

**Left-Hand With 1/2" Cord Drop**

23 1/2"	18 3/8"	36"	14"	<b>UT2136L</b>	\$528	\$1523	+\$56
23 1/2"	18 3/8"	42"	20"	<b>UT2142L</b>	\$562	\$1557	+\$62
23 1/2"	18 3/8"	48"	26"	<b>UT2148L</b>	\$653	\$1648	+\$63
23 1/2"	18 3/8"	54"	32"	<b>UT2154L</b>	\$700	\$1695	+\$66
23 1/2"	18 3/8"	60"	38"	<b>UT2160L</b>	\$743	\$1738	+\$73
29 1/2"	23 1/2"	36"	14"	<b>UT3236L</b>	\$626	\$1621	+\$62
29 1/2"	23 1/2"	42"	20"	<b>UT3242L</b>	\$656	\$1651	+\$63
29 1/2"	23 1/2"	48"	26"	<b>UT3248L</b>	\$766	\$1761	+\$66
29 1/2"	23 1/2"	54"	32"	<b>UT3254L</b>	\$823	\$1818	+\$73
29 1/2"	23 1/2"	60"	38"	<b>UT3260L</b>	\$874	\$1869	+\$78

**Left-Hand With Full Depth**

30"	24"	36"	18"	<b>WT3236</b>	\$626		
30"	24"	42"	24"	<b>WT3242</b>	\$656		
30"	24"	48"	30"	<b>WT3248</b>	\$766		
30"	24"	54"	36"	<b>WT3254</b>	\$823		
30"	24"	60"	42"	<b>WT3260</b>	\$874		

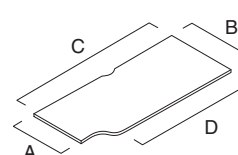
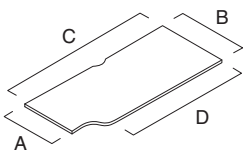

**Right-Hand With 1/2" Cord Drop**

18 3/8"	23 1/2"	36"	14"	<b>UT1236R</b>	\$528	\$1523	+\$56
18 3/8"	23 1/2"	42"	20"	<b>UT1242R</b>	\$562	\$1557	+\$62
18 3/8"	23 1/2"	48"	26"	<b>UT1248R</b>	\$653	\$1648	+\$63
18 3/8"	23 1/2"	54"	32"	<b>UT1254R</b>	\$700	\$1695	+\$66
18 3/8"	23 1/2"	60"	38"	<b>UT1260R</b>	\$743	\$1738	+\$73
23 1/2"	29 1/2"	36"	14"	<b>UT2336R</b>	\$626	\$1621	+\$62
23 1/2"	29 1/2"	42"	20"	<b>UT2342R</b>	\$656	\$1651	+\$63
23 1/2"	29 1/2"	48"	26"	<b>UT2348R</b>	\$766	\$1761	+\$66
23 1/2"	29 1/2"	54"	32"	<b>UT2354R</b>	\$823	\$1818	+\$73
23 1/2"	29 1/2"	60"	38"	<b>UT2360R</b>	\$874	\$1869	+\$78

**Right-Hand With Full Depth**

24"	30"	36"	18"	<b>WT2336</b>	\$626		
24"	30"	42"	24"	<b>WT2342</b>	\$656		
24"	30"	48"	30"	<b>WT2348</b>	\$766		
24"	30"	54"	36"	<b>WT2354</b>	\$823		
24"	30"	60"	42"	<b>WT2360</b>	\$874		

# Tapered Worksurfaces

## High-Pressure Laminate

Tip: Supports for freestanding and panel-mounted applications must be specified separately.

Tip: Long worksurface spans require additional support.  
▶ See understanding section for details, page 88

For laminate group 2 and 3 pricing, please refer to the electronic catalog or SmartTools.

Tip: Power and data access door and tray is ordered separately to be used with cutout.  
▶ See page 260

Tip: To specify 3 mm edge profile, no suffix is required.

Standard Includes	Required to Specify
<ul style="list-style-type: none"> <li>▶ Need help? Product details, page 86</li> <li>• Worksurface: High-Pressure Laminate price group 1</li> <li>• Laminate worksurface:                             <ul style="list-style-type: none"> <li>–Plastic 3 mm edge profile on front edge</li> <li>–Plastic default flat profile on side and back edges</li> </ul> </li> <li>• Cable scallop on back edge</li> </ul>	<ol style="list-style-type: none"> <li>1 Style number with appropriate edge profile suffix                             <ul style="list-style-type: none"> <li><b>K</b> Laminate with knife edge</li> </ul> </li> <li>▶ See edge profiles below.</li> <li>2 High-Pressure Laminate color number for worksurface</li> <li>3 Plastic color number for front edge on laminate worksurface</li> <li>4 Options, if selected (see below)</li> <li>▶ See <i>Surface Materials</i>, page 360.</li> </ol>

Options	U.S. Price	Required to Specify
<b>Surface Materials</b> <ul style="list-style-type: none"> <li>• High-Pressure Laminate worksurfaces                             <ul style="list-style-type: none"> <li>• Laminate price group 2</li> <li>• Laminate price group 3</li> <li>• Open Line laminate</li> </ul> </li> </ul>	See information at left See information at left +\$102 plus cost of laminate	Specify laminate color number. Specify laminate color number. ▶ See <i>Surface Materials Reference Manual</i> .
<b>Scallop</b> <ul style="list-style-type: none"> <li>• Omit scallop</li> </ul>	No cost	Specify omit scallop.
<b>Cutout for Power and Data Access Door and Tray</b> <ul style="list-style-type: none"> <li>• Cutout</li> </ul>	No cost	Specify with cutout for power and data access door.
<b>Related Products</b> <ul style="list-style-type: none"> <li>• Panel-mounted Universal Systems worksurface supports</li> <li>• Legs and supports for Universal Systems Worksurfaces</li> </ul>		▶ Page 262 ▶ Page 266

### Specification Information

U.S. Base Price High-Pressure Laminate			U.S. Base Prices High-Pressure Laminate		
Dimensions	Style Number	Plastic 3 mm Edge	Dimensions	Style Number	Plastic 3 mm Edge
A B C			A B C		No Suffix
					Suffix K

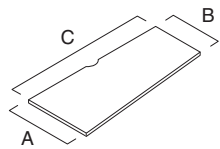

Left-Hand With 1/2" Cord Drop					
Dimensions	Style Number	U.S. Price	U.S. Price	U.S. Price	U.S. Price
A B C					
23 1/2" 18 3/8" 48"	UTT2148	\$653			
23 1/2" 18 3/8" 60"	UTT2160	\$743			
23 1/2" 18 3/8" 72"	UTT2172	\$832			
29 1/2" 23 1/2" 48"	UTT3248	\$766			
29 1/2" 23 1/2" 60"	UTT3260	\$874			
29 1/2" 23 1/2" 72"	UTT3272	\$979			

Left-Hand With Full Depth					
Dimensions	Style Number	U.S. Price	U.S. Price	U.S. Price	U.S. Price
A B C					
24" 18 7/8" 48"	WTT2148	\$653	\$ 731		
24" 18 7/8" 60"	WTT2160	\$743	\$ 836		
24" 18 7/8" 72"	WTT2172	\$832	\$ 925		
30" 24" 48"	WTT3248	\$766	\$ 844		
30" 24" 60"	WTT3260	\$874	\$ 967		
30" 24" 72"	WTT3272	\$979	\$1072		

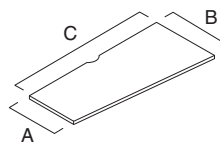

Right-Hand With 1/2" Cord Drop					
Dimensions	Style Number	U.S. Price	U.S. Price	U.S. Price	U.S. Price
A B C					
18 3/8" 23 1/2" 48"	UTT1248	\$653			
18 3/8" 23 1/2" 60"	UTT1260	\$743			
18 3/8" 23 1/2" 72"	UTT1272	\$832			
23 1/2" 29 1/2" 48"	UTT2348	\$766			
23 1/2" 29 1/2" 60"	UTT2360	\$874			
23 1/2" 29 1/2" 72"	UTT2372	\$979			

Right-Hand With Full Depth					
Dimensions	Style Number	U.S. Price	U.S. Price	U.S. Price	U.S. Price
A B C					
18 7/8" 24" 48"	WTT1248	\$653	\$ 731		
18 7/8" 24" 60"	WTT1260	\$743	\$ 836		
18 7/8" 24" 72"	WTT1272	\$832	\$ 925		
24" 30" 48"	WTT2348	\$766	\$ 844		
24" 30" 60"	WTT2360	\$874	\$ 967		
24" 30" 72"	WTT2372	\$979	\$1072		

 **For Canadian Pricing**  
Multiply U.S. Price by the Canadian price factor.  
▶ See page 1 for details.

# Tapered Worksurfaces with Soft Edge Profile

Tapered Worksurfaces with Soft Edge Profile

*Tip: Supports for freestanding and panel-mounted applications must be specified separately.*

*Tip: Long worksurface spans require additional support.*  
▶ See understanding section for details, page 88

**For laminate group 2 and 3 pricing,** please refer to the electronic catalog or SmartTools.

*Tip: Power and data access door and tray is ordered separately to be used with cutout.*

▶ See page 260

*Exception: 48"W worksurface with soft edge cannot have a post leg at the front edge.*

Standard Includes		Required to Specify	
▶ Need help? Product details, page 86	<ul style="list-style-type: none"> <li>• Worksurface: High-Pressure Laminate price group 1</li> <li>• Laminate worksurface:                             <ul style="list-style-type: none"> <li>- Plastic antimicrobial soft edge profile centered on worksurface</li> <li>- Plastic 3 mm edge profile on balance of front edge</li> <li>- Plastic flat profile on side and back edges</li> </ul> </li> <li>• Cable scallop on back edge</li> </ul>	<ol style="list-style-type: none"> <li>1 Style number</li> <li>2 High-Pressure Laminate color number for worksurface</li> <li>3 Plastic color number for front edge on laminate worksurface</li> <li>4 Options, if selected (see below)</li> </ol>	▶ See <i>Surface Materials</i> , page 360.

Options	U.S. Price	Required to Specify	
<b>Surface Materials</b> <ul style="list-style-type: none"> <li>• High-Pressure Laminate worksurfaces</li> <li>• Laminate price group 2</li> <li>• Laminate price group 3</li> <li>• Open Line laminate</li> </ul>	See information at left See information at left +\$102 plus cost of laminate	Specify laminate color number. Specify laminate color number. ▶ See <i>Surface Materials Reference Manual</i> .	
<b>Soft Edge</b> <ul style="list-style-type: none"> <li>• Antimicrobial edge</li> <li>• No antimicrobial edge</li> </ul>	No cost No cost	Specify <i>with antimicrobial soft edge</i> . Specify <i>without antimicrobial soft edge</i> .	
<b>Scallop</b> <ul style="list-style-type: none"> <li>• Omit scallop</li> </ul>	No cost	Specify omit scallop.	
<b>Cutout for Power and Data Access Door and Tray</b> <ul style="list-style-type: none"> <li>• Cutout</li> </ul>	No cost	Specify <i>with cutout for power and data access door</i> .	
<b>Related Products</b> <ul style="list-style-type: none"> <li>• Panel-mounted Universal Systems worksurface supports</li> <li>• Legs and supports for Universal Systems Worksurfaces</li> </ul>		▶ Page 262	▶ Page 266

## Specification Information

Dimensions			Style Number	U.S. Base Price	Dimensions			Style Number	U.S. Base Price
A	B	C			A	B	C		

### Left-Hand With 1/2" Cord Drop

29 1/2"	23 1/2"	48"	<b>UTT3248S</b>	\$1252
29 1/2"	23 1/2"	60"	<b>UTT3260S</b>	\$1360
29 1/2"	23 1/2"	72"	<b>UTT3272S</b>	\$1465
:	:	:	:	:

### Left-Hand With Full Depth

30"	24"	48"	<b>WTT3248S</b>	\$1252
30"	24"	60"	<b>WTT3260S</b>	\$1360
30"	24"	72"	<b>WTT3272S</b>	\$1465
:	:	:	:	:

### Right-Hand With 1/2" Cord Drop

23 1/2"	29 1/2"	48"	<b>UTT2348S</b>	\$1252
23 1/2"	29 1/2"	60"	<b>UTT2360S</b>	\$1360
23 1/2"	29 1/2"	72"	<b>UTT2372S</b>	\$1465
:	:	:	:	:

### Right-Hand With Full Depth

24"	30"	48"	<b>WTT2348S</b>	\$1252
24"	30"	60"	<b>WTT2360S</b>	\$1360
24"	30"	72"	<b>WTT2372S</b>	\$1465
:	:	:	:	:

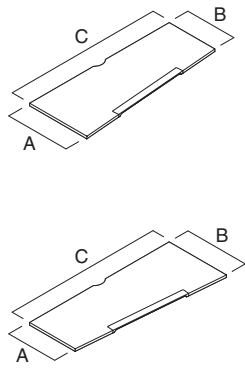

 **For Canadian Pricing**  
Multiply U.S. Price by the Canadian price factor.  
▶ See page 1 for details.

# Taper-Flat Worksurfaces

High-Pressure Laminate

*Tip: Supports for freestanding and panel-mounted applications must be specified separately.*

*Tip: Long worksurface spans require additional support.*

▶ See understanding section for details, page 88

**For laminate group 2 and 3 pricing, please refer to the electronic catalog or SmartTools.**



Standard Includes		Required to Specify
-------------------	--	---------------------

▶ Need help? Product details, page 86	<ul style="list-style-type: none"> <li>• Worksurface: High-Pressure Laminate price group 1</li> <li>• Laminate worksurface:                             <ul style="list-style-type: none"> <li>–Plastic 3 mm edge profile on front edge</li> <li>–Plastic default flat profile on side and back edges</li> </ul> </li> <li>• Cable scallop on back edge</li> </ul>	<ol style="list-style-type: none"> <li>1 Style number</li> <li>2 High-Pressure Laminate color number for worksurface</li> <li>3 Plastic color number for front edge on laminate worksurface</li> <li>4 Options, if selected (see below)</li> </ol> <p>▶ See <i>Surface Materials</i>, page 360.</p>
---------------------------------------	--	---

Options	U.S. Price	Required to Specify
---------	------------	---------------------

<b>Surface Materials</b> <ul style="list-style-type: none"> <li>• High-Pressure Laminate worksurfaces</li> <li>• Laminate price group 2</li> <li>• Laminate price group 3</li> <li>• Open Line laminate</li> </ul>	See information at left See information at left +\$102 plus cost of laminate	Specify laminate color number. Specify laminate color number. ▶ See <i>Surface Materials Reference Manual</i> .
<b>Scallop</b> <ul style="list-style-type: none"> <li>• Omit scallop</li> </ul>	No cost	Specify <i>omit scallop</i> .
<b>Related Products</b> <ul style="list-style-type: none"> <li>• Panel-mounted Universal Systems worksurface supports</li> <li>• Legs and supports for Universal Systems Worksurfaces</li> </ul>		▶ Page 262 ▶ Page 266

### Specification Information

			U.S. Base Price High-Pressure Laminate			U.S. Base Price High-Pressure Laminate		
								
• Dimensions	• Style Number	• Plastic 3 mm Edge	• Dimensions	• Style Number	• Plastic 3 mm Edge	• Dimensions	• Style Number	• Plastic 3 mm Edge
A B C			A B C			A B C		

#### Left-Hand With 1/2" Cord Drop

23 1/2"	18 3/8"	60"	<b>UTTF2160</b>	\$743
23 1/2"	18 3/8"	72"	<b>UTTF2172</b>	\$832
29 1/2"	18 3/8"	60"	<b>UTTF3160</b>	\$874
29 1/2"	18 3/8"	72"	<b>UTTF3172</b>	\$979
29 1/2"	23 1/2"	60"	<b>UTTF3260</b>	\$874
29 1/2"	23 1/2"	72"	<b>UTTF3272</b>	\$979

#### Left-Hand With Full Depth

24"	18 7/8"	60"	<b>WTTF2160</b>	\$743
24"	18 7/8"	72"	<b>WTTF2172</b>	\$832
30"	18 7/8"	60"	<b>WTTF3160</b>	\$874
30"	18 7/8"	72"	<b>WTTF3172</b>	\$979
30"	24"	60"	<b>WTTF3260</b>	\$874
30"	24"	72"	<b>WTTF3272</b>	\$979

#### Right-Hand With 1/2" Cord Drop

18 3/8"	23 1/2"	60"	<b>UTTF1260</b>	\$743
18 3/8"	23 1/2"	72"	<b>UTTF1272</b>	\$832
18 3/8"	29 1/2"	60"	<b>UTTF1360</b>	\$874
18 3/8"	29 1/2"	72"	<b>UTTF1372</b>	\$979
23 1/2"	29 1/2"	60"	<b>UTTF2360</b>	\$874
23 1/2"	29 1/2"	72"	<b>UTTF2372</b>	\$979

#### Right-Hand With Full Depth

18 7/8"	24"	60"	<b>WTTF1260</b>	\$743
18 7/8"	24"	72"	<b>WTTF1272</b>	\$832
18 7/8"	30"	60"	<b>WTTF1360</b>	\$874
18 7/8"	30"	72"	<b>WTTF1372</b>	\$979
24"	30"	60"	<b>WTTF2360</b>	\$874
24"	30"	72"	<b>WTTF2372</b>	\$979

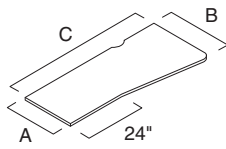
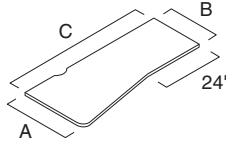

 **For Canadian Pricing**  
 Multiply U.S. Price by the Canadian price factor.  
 ▶ See page 1 for details.

# Single-Tapered Worksurfaces

High-Pressure Laminate

Single-Tapered  
Worksurfaces

*Tip: Supports for freestanding and panel-mounted applications must be specified separately.*

*Tip: Long worksurface spans require additional support.*

▶ See understanding section for details, page 88

**For laminate group 2 and 3 pricing, please refer to the electronic catalog or SmartTools.**

Standard Includes		Required to Specify	
▶ Need help? Product details, page 86	<ul style="list-style-type: none"> <li>• Worksurface: High-Pressure Laminate price group 1</li> <li>• Laminate worksurface:                             <ul style="list-style-type: none"> <li>–Plastic 3 mm edge profile on front edge</li> <li>–Plastic default flat profile on side and back edges</li> </ul> </li> <li>• Cable scallop on back edge</li> </ul>	<ol style="list-style-type: none"> <li>1 Style number</li> <li>2 High-Pressure Laminate color number for worksurface</li> <li>3 Plastic color number for front edge on laminate worksurface</li> <li>4 Options, if selected (see below)</li> </ol>	▶ See <i>Surface Materials</i> , page 360.

Options	U.S. Price	Required to Specify	
<b>Surface Materials</b> <ul style="list-style-type: none"> <li>• High-Pressure Laminate worksurfaces</li> <li>• Laminate price group 2</li> <li>• Laminate price group 3</li> <li>• Open Line laminate</li> </ul>	See information at left See information at left +\$102 plus cost of laminate	Specify laminate color number. Specify laminate color number. ▶ See <i>Surface Materials Reference Manual</i> .	
<b>Scallop</b> <ul style="list-style-type: none"> <li>• Omit scallop</li> </ul>	No cost	Specify <i>omit scallop</i> .	
<b>Related Products</b> <ul style="list-style-type: none"> <li>• Panel-mounted Universal Systems worksurface supports</li> <li>• Legs and supports for Universal Systems Worksurfaces</li> </ul>		▶ Page 262 ▶ Page 266	

## Specification Information

			U.S. Base Price High-Pressure Laminate						U.S. Base Price High-Pressure Laminate			
Dimensions			Style Number	Plastic 3 mm Edge	Dimensions			Style Number	Plastic 3 mm Edge	Dimensions		
A	B	C			A	B	C			A	B	C
												
<b>Left-Hand With 1/2" Cord Drop</b>						<b>Left-Hand With Full Depth</b>						
23 1/2"	18 3/8"	60"	<b>UST2160</b>	\$743	24"	18 7/8"	60"	<b>WST2160</b>	\$743			
23 1/2"	18 3/8"	72"	<b>UST2172</b>	\$832	24"	18 7/8"	72"	<b>WST2172</b>	\$832			
29 1/2"	23 1/2"	60"	<b>UST3260</b>	\$874	30"	24"	60"	<b>WST3260</b>	\$874			
29 1/2"	23 1/2"	72"	<b>UST3272</b>	\$979	30"	24"	72"	<b>WST3272</b>	\$979			
:	:	:	:	:	:	:	:	:	:			
<b>Right-Hand With 1/2" Cord Drop</b>						<b>Right-Hand With Full Depth</b>						
18 3/8"	23 1/2"	60"	<b>UST1260</b>	\$743	18 7/8"	24"	60"	<b>WST1260</b>	\$743			
18 3/8"	23 1/2"	72"	<b>UST1272</b>	\$832	18 7/8"	24"	72"	<b>WST1272</b>	\$832			
23 1/2"	29 1/2"	60"	<b>UST2360</b>	\$874	24"	30"	60"	<b>WST2360</b>	\$874			
23 1/2"	29 1/2"	72"	<b>UST2372</b>	\$979	24"	30"	72"	<b>WST2372</b>	\$979			
:	:	:	:	:	:	:	:	:	:			

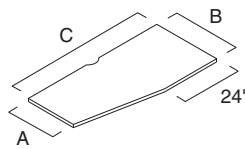
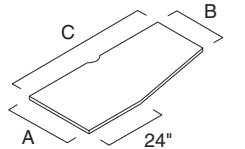

 **For Canadian Pricing**  
 Multiply U.S. Price by the Canadian price factor.  
 ▶ See page 1 for details.

# Corner, Flat-Front Worksurfaces

High-Pressure Laminate

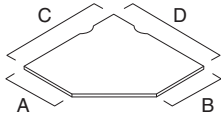

*Tip: Supports must be specified separately, including side support brackets for rear corner support in panel-mounted applications.*

*Tip: To specify 3 mm edge profile, no suffix is required.*

**For laminate group 2 and 3 pricing,** please refer to the electronic catalog or SmartTools.

Standard Includes		Required to Specify
<ul style="list-style-type: none"> <li>▶ Need help? Product details, page 86</li> </ul>	<ul style="list-style-type: none"> <li>• Worksurface: High-Pressure Laminate price group 1                             <ul style="list-style-type: none"> <li>–Plastic 3 mm edge profile on front edge</li> <li>–Plastic default flat profile on side and back edges</li> </ul> </li> <li>• Cable scallops on back edges</li> </ul>	<ol style="list-style-type: none"> <li>1 Style number</li> <li>2 High-Pressure Laminate color number for worksurface</li> <li>3 Plastic color number for front edge on laminate worksurface</li> <li>4 Options, if selected (see below)                             <ul style="list-style-type: none"> <li>▶ See <i>Surface Materials</i>, page 360.</li> </ul> </li> </ol>
Options	U.S. Price	Required to Specify
<b>Surface Materials</b> <ul style="list-style-type: none"> <li>• High-Pressure Laminate worksurfaces                             <ul style="list-style-type: none"> <li>• Laminate price group 2</li> <li>• Laminate price group 3</li> <li>• Open Line laminate</li> </ul> </li> </ul>	See information at left See information at left +\$102 plus cost of laminate	Specify laminate color number. Specify laminate color number. ▶ See <i>Surface Materials Reference Manual</i> .
<b>Scallops</b> <ul style="list-style-type: none"> <li>• Omit scallops</li> </ul>	No cost	Specify <i>omit scallops</i> .
<b>Related Products</b> <ul style="list-style-type: none"> <li>• Panel-mounted Universal Systems worksurface supports</li> <li>• Legs and supports for Universal Systems Worksurfaces</li> </ul>		▶ Page 262 ▶ Page 266

## Specification Information

				U.S. Base Price High-Pressure Laminate							U.S. Base Price High-Pressure Laminate			
• Dimensions				• Style Number	• Plastic 3 mm Edge	• Dimensions				• Style Number	• Plastic 3 mm Edge			
A	B	C	D			A	B	C	D					
<b>With 1/2" Cord Drop</b>												<b>With Full Depth</b>		
23 1/2"	23 1/2"	35 1/2"	35 1/2"	<b>UCF223636</b>	\$560	24"	24"	36"	36"	<b>WCF223636</b>	\$560			
23 1/2"	23 1/2"	41 1/2"	41 1/2"	<b>UCF224242</b>	\$610	24"	24"	42"	42"	<b>WCF224242</b>	\$610			
23 1/2"	23 1/2"	47 1/2"	47 1/2"	<b>UCF224848</b>	\$691	24"	24"	48"	48"	<b>WCF224848</b>	\$691			
29 1/2"	29 1/2"	41 1/2"	41 1/2"	<b>UCF334242</b>	\$671	30"	30"	42"	42"	<b>WCF334242</b>	\$671			
29 1/2"	29 1/2"	47 1/2"	47 1/2"	<b>UCF334848</b>	\$760	30"	30"	48"	48"	<b>WCF334848</b>	\$760			



### For Canadian Pricing

Multiply U.S. Price by the Canadian price factor.

▶ See page 1 for details.

# Dual Corner, Flat-Front Worksurfaces

High-Pressure Laminate

Dual Corner, Flat-Front  
Worksurfaces

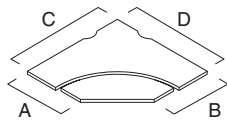

*Tip: Supports must be specified separately, including side support brackets for rear corner support in panel-mounted applications.*

**For laminate group 2 and 3 pricing, please refer to the electronic catalog or SmartTools.**

*Tip: Keyboard surface adjusts 6" higher or 5" lower than work surface height.*

*Tip: Dual corner, flat-front work surfaces must be panel hung.*

*Tip: 23½" D dual corner, flat-front work surfaces must be supported with a center support on each side.*

*Tip: 29½" D dual corner, flat-front work surfaces can be supported with a cantilever or center support.*

*Tip: To specify 3 mm edge profile, no suffix is required.*

Standard Includes		Required to Specify	
<ul style="list-style-type: none"> <li>▶ Need help? Product details, page 86</li> </ul>	<ul style="list-style-type: none"> <li>• Worksurface: High-Pressure Laminate price group 1</li> <li>• Laminate work surface:                             <ul style="list-style-type: none"> <li>–Plastic 3 mm edge profile on front edge of keyboard surface</li> <li>–Plastic default flat profile on all other edges</li> </ul> </li> <li>• Cable scallops on back edges</li> <li>• Keyboard mechanism</li> </ul>	<ol style="list-style-type: none"> <li>1 Style number</li> <li>2 High-Pressure Laminate color number for work surface</li> <li>3 Plastic color number for edges on laminate work surface</li> <li>4 Options, if selected (see below)</li> </ol>	<ul style="list-style-type: none"> <li>▶ See <i>Surface Materials</i>, page 360.</li> </ul>
Options		Required to Specify	
<b>Surface Materials</b> <ul style="list-style-type: none"> <li>• Laminate price group 2</li> <li>• Laminate price group 3</li> <li>• Open Line laminate</li> </ul>	<b>High-Pressure Laminate work surfaces</b> <ul style="list-style-type: none"> <li>• See information at left</li> <li>• See information at left +\$102 plus cost of laminate</li> </ul>	<ul style="list-style-type: none"> <li>• Specify laminate color number.</li> <li>• Specify laminate color number.</li> </ul>	<ul style="list-style-type: none"> <li>▶ See <i>Surface Materials Reference Manual</i>.</li> </ul>
<b>Scallops</b> <ul style="list-style-type: none"> <li>• Omit scallops</li> </ul>	<ul style="list-style-type: none"> <li>• No cost</li> </ul>	<ul style="list-style-type: none"> <li>• Specify omit scallops.</li> </ul>	
<b>Related Products</b> <ul style="list-style-type: none"> <li>• Panel-mounted Universal Systems work surface supports</li> <li>• Legs and supports for Universal Systems Worksurfaces</li> </ul>		<ul style="list-style-type: none"> <li>▶ Page 262</li> <li>▶ Page 266</li> </ul>	

## Specification Information

				U.S. Base Price High-Pressure Laminate							U.S. Base Price High-Pressure Laminate									
• Dimensions				• Style Number			• Plastic 3 mm Edge			• Dimensions				• Style Number			• Plastic 3 mm Edge			
A	B	C	D				A	B	C	D				A	B	C	D			
<b>With ½" Cord Drop</b>							<b>With Full Depth</b>													
23½"	23½"	41½"	41½"	<b>UDC224242</b>	\$1493		24"	24"	42"	42"	<b>WDC224242</b>	\$1493		24"	24"	48"	48"	<b>WDC224848</b>	\$1575	
23½"	23½"	47½"	47½"	<b>UDC224848</b>	\$1575		24"	24"	48"	48"	<b>WDC224848</b>	\$1575		30"	30"	48"	48"	<b>WDC334848</b>	\$1637	
29½"	29½"	47½"	47½"	<b>UDC334848</b>	\$1637															

**For Canadian Pricing**  
Multiply U.S. Price by the Canadian price factor.  
▶ See page 1 for details.

# Corner, Straight-Front Worksurfaces

High-Pressure Laminate

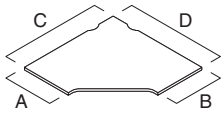

*Tip: Supports must be specified separately, including side support brackets for rear corner support in panel-mounted applications.*

**For laminate group 2 and 3 pricing, please refer to the electronic catalog or SmartTools.**

Standard Includes	Required to Specify
<ul style="list-style-type: none"> <li>▶ Need help? Product details, page 86</li> <li>• Worksurface: High-Pressure Laminate price group 1                             <ul style="list-style-type: none"> <li>–Plastic 3 mm edge profile on front edge</li> <li>–Plastic default flat profile on side and back edges</li> </ul> </li> <li>• Cable scallops on back edges</li> </ul>	<ol style="list-style-type: none"> <li>1 Style number</li> <li>2 High-Pressure Laminate color number for worksurface</li> <li>3 Plastic color number for front edge on laminate worksurface</li> <li>4 Options, if selected (see below)                             <ul style="list-style-type: none"> <li>▶ See <i>Surface Materials</i>, page 360.</li> </ul> </li> </ol>

Options	U.S. Price	Required to Specify
<b>Surface Materials</b> <ul style="list-style-type: none"> <li>• High-Pressure Laminate worksurfaces                             <ul style="list-style-type: none"> <li>• Laminate price group 2</li> <li>• Laminate price group 3</li> <li>• Open Line laminate</li> </ul> </li> </ul>	See information at left See information at left +\$102 plus cost of laminate	Specify laminate color number. Specify laminate color number. ▶ See <i>Surface Materials Reference Manual</i> .
<b>Scallops</b> <ul style="list-style-type: none"> <li>• Omit scallops</li> </ul>	No cost	Specify <i>omit scallops</i> .
<b>Related Products</b> <ul style="list-style-type: none"> <li>• Panel-mounted Universal Systems worksurface supports</li> <li>• Legs and supports for Universal Systems Worksurfaces</li> </ul>		▶ Page 262 ▶ Page 266

## Specification Information

				U.S. Base Prices High-Pressure Laminate	
					
• Dimensions				• Style Number	• Plastic 3 mm Edge
A	B	C	D		
<hr/>					
<b>With 1/2" Cord Drop</b>					
18"	18"	42"	42"	<b>UC114242</b>	\$ 583
18 <sup>3</sup> / <sub>8</sub> "	23 <sup>1</sup> / <sub>2</sub> "	41 <sup>1</sup> / <sub>2</sub> "	41 <sup>1</sup> / <sub>2</sub> "	<b>UC124242</b>	\$ 644
23 <sup>1</sup> / <sub>2</sub> "	18 <sup>3</sup> / <sub>8</sub> "	41 <sup>1</sup> / <sub>2</sub> "	41 <sup>1</sup> / <sub>2</sub> "	<b>UC214242</b>	\$ 644
23 <sup>1</sup> / <sub>2</sub> "	23 <sup>1</sup> / <sub>2</sub> "	35 <sup>1</sup> / <sub>2</sub> "	35 <sup>1</sup> / <sub>2</sub> "	<b>UC223636</b>	\$ 560
23 <sup>1</sup> / <sub>2</sub> "	23 <sup>1</sup> / <sub>2</sub> "	41 <sup>1</sup> / <sub>2</sub> "	41 <sup>1</sup> / <sub>2</sub> "	<b>UC224242</b>	\$ 610
23 <sup>1</sup> / <sub>2</sub> "	23 <sup>1</sup> / <sub>2</sub> "	47 <sup>1</sup> / <sub>2</sub> "	47 <sup>1</sup> / <sub>2</sub> "	<b>UC224848</b>	\$ 691
23 <sup>1</sup> / <sub>2</sub> "	23 <sup>1</sup> / <sub>2</sub> "	59 <sup>1</sup> / <sub>2</sub> "	59 <sup>1</sup> / <sub>2</sub> "	<b>UC226060</b>	\$1282
29 <sup>1</sup> / <sub>2</sub> "	29 <sup>1</sup> / <sub>2</sub> "	41 <sup>1</sup> / <sub>2</sub> "	41 <sup>1</sup> / <sub>2</sub> "	<b>UC334242</b>	\$ 671
29 <sup>1</sup> / <sub>2</sub> "	29 <sup>1</sup> / <sub>2</sub> "	47 <sup>1</sup> / <sub>2</sub> "	47 <sup>1</sup> / <sub>2</sub> "	<b>UC334848</b>	\$ 760
⋮	⋮	⋮	⋮	⋮	⋮



**For Canadian Pricing**  
 Multiply U.S. Price by the Canadian price factor.  
 ▶ See page 1 for details.

# Corner, Curved-Front Worksurfaces

High-Pressure Laminate or Wood Veneer

Corner, Curved-Front  
Worksurfaces

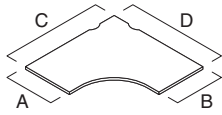

Tip: Supports must be specified separately, including side support brackets for rear corner support in panel-mounted applications.

Standard Includes	Required to Specify
<ul style="list-style-type: none"> <li>Need help? Product details, page 86</li> <li>Worksurface: High-Pressure Laminate price group 1 or wood group 1 veneer</li> <li>Laminate worksurface:                             <ul style="list-style-type: none"> <li>–Plastic 3 mm edge profile on front edge</li> <li>–Plastic default flat profile on side and back edges</li> </ul> </li> <li>Wood worksurface:                             <ul style="list-style-type: none"> <li>–Wood 3 mm edge profile on front edge</li> <li>–Matching veneer flat profile on side and back edges</li> </ul> </li> <li>Cable scallops on back edges</li> </ul>	<ol style="list-style-type: none"> <li>Style number with appropriate edge profile suffix                             <ul style="list-style-type: none"> <li><b>SW</b> Wood with square edge</li> </ul> </li> <li>See edge profiles below.</li> <li>High-Pressure Laminate or wood color number for worksurface</li> <li>Plastic color number for front edge on laminate worksurface, if selected</li> <li>Options, if selected (see below)</li> <li>See <i>Surface Materials</i>, page 360.</li> </ol>

**For wood and laminate group 2 and 3 pricing, please refer to the electronic catalog or SmartTools.**

Tip: To specify 3 mm edge profile, no suffix is required. For all other edge profiles, add a suffix to the style number. (For example, UCC114242 becomes UCC114242SW for wood with square edge profile.)

Options	U.S. Price	Required to Specify
<b>Surface Materials</b> <ul style="list-style-type: none"> <li><b>High-Pressure Laminate worksurfaces</b> <ul style="list-style-type: none"> <li>Laminate price group 2</li> <li>Laminate price group 3</li> <li>Open Line laminate</li> </ul> </li> <li><b>Wood veneer worksurfaces</b> <ul style="list-style-type: none"> <li>Wood group 2</li> <li>Wood group 3</li> <li>Customiz stain</li> </ul> </li> <li>Full-fill finish on wood group 1</li> </ul>	<ul style="list-style-type: none"> <li>See information at left</li> <li>See information at left +\$102 plus cost of laminate</li> <li>See information at left</li> <li>See information at left</li> <li>No cost</li> <li>Prices below</li> <li>No cost</li> </ul>	<ul style="list-style-type: none"> <li>Specify laminate color number.</li> <li>Specify laminate color number.</li> <li>See <i>Surface Materials Reference Manual</i>.</li> <li>Specify wood color number.</li> <li>Specify wood color number.</li> <li>Specify with <i>Customiz stain</i>.</li> <li>See <i>Surface Materials Reference Manual</i>.</li> <li>Specify full-fill finish number.</li> <li>Specify <i>omit scallops</i>.</li> </ul>
<b>Scallops</b> <ul style="list-style-type: none"> <li>Omit scallops</li> </ul>	No cost	Specify <i>omit scallops</i> .
<b>Related Products</b> <ul style="list-style-type: none"> <li>Panel-mounted Universal Systems worksurface supports</li> <li>Legs and supports for Universal Systems Worksurfaces</li> </ul>		<ul style="list-style-type: none"> <li>Page 262</li> <li>Page 266</li> </ul>

## Specification Information

Dimensions A B C D	Style Number	U.S. Base Prices		Option (Add \$ to Base Price)	Dimensions A B C D	Style Number	U.S. Base Price	
		High-Pressure Laminate	Wood				High-Pressure Laminate	
		Plastic 3 mm Edge	Wood Square Edge				Plastic 3 mm Edge	
		No Suffix	Suffix SW	Full-Fill Finish on Wood Group 1				

### With 1/2" Cord Drop

18 <sup>3</sup> / <sub>8</sub> "	18 <sup>3</sup> / <sub>8</sub> "	35 <sup>1</sup> / <sub>2</sub> "	35 <sup>1</sup> / <sub>2</sub> "	<b>UCC113636</b>	\$ 650	N.A.	N.A.
18 <sup>3</sup> / <sub>8</sub> "	18 <sup>3</sup> / <sub>8</sub> "	41 <sup>1</sup> / <sub>2</sub> "	41 <sup>1</sup> / <sub>2</sub> "	<b>UCC114242</b>	\$ 691	\$1645	+\$80
18 <sup>3</sup> / <sub>8</sub> "	18 <sup>3</sup> / <sub>8</sub> "	47 <sup>1</sup> / <sub>2</sub> "	47 <sup>1</sup> / <sub>2</sub> "	<b>UCC114848</b>	\$ 772	N.A.	N.A.
18 <sup>3</sup> / <sub>8</sub> "	23 <sup>1</sup> / <sub>2</sub> "	41 <sup>1</sup> / <sub>2</sub> "	41 <sup>1</sup> / <sub>2</sub> "	<b>UCC124242</b>	\$ 743	\$1697	+\$80
23 <sup>1</sup> / <sub>2</sub> "	18 <sup>3</sup> / <sub>8</sub> "	41 <sup>1</sup> / <sub>2</sub> "	41 <sup>1</sup> / <sub>2</sub> "	<b>UCC214242</b>	\$ 743	\$1697	+\$80
23 <sup>1</sup> / <sub>2</sub> "	23 <sup>1</sup> / <sub>2</sub> "	35 <sup>1</sup> / <sub>2</sub> "	35 <sup>1</sup> / <sub>2</sub> "	<b>UCC223636</b>	\$ 657	\$1611	+\$80
23 <sup>1</sup> / <sub>2</sub> "	23 <sup>1</sup> / <sub>2</sub> "	41 <sup>1</sup> / <sub>2</sub> "	41 <sup>1</sup> / <sub>2</sub> "	<b>UCC224242</b>	\$ 717	\$1671	+\$80
23 <sup>1</sup> / <sub>2</sub> "	23 <sup>1</sup> / <sub>2</sub> "	47 <sup>1</sup> / <sub>2</sub> "	47 <sup>1</sup> / <sub>2</sub> "	<b>UCC224848</b>	\$ 797	\$1751	+\$85
23 <sup>1</sup> / <sub>2</sub> "	23 <sup>1</sup> / <sub>2</sub> "	59 <sup>1</sup> / <sub>2</sub> "	59 <sup>1</sup> / <sub>2</sub> "	<b>UCC226060</b>	\$1282	N.A.	N.A.
29 <sup>1</sup> / <sub>2</sub> "	29 <sup>1</sup> / <sub>2</sub> "	41 <sup>1</sup> / <sub>2</sub> "	41 <sup>1</sup> / <sub>2</sub> "	<b>UCC334242</b>	\$ 776	\$1730	+\$81
29 <sup>1</sup> / <sub>2</sub> "	29 <sup>1</sup> / <sub>2</sub> "	47 <sup>1</sup> / <sub>2</sub> "	47 <sup>1</sup> / <sub>2</sub> "	<b>UCC334848</b>	\$ 868	\$1822	+\$87

### With Full Depth

18 <sup>7</sup> / <sub>8</sub> "	18 <sup>7</sup> / <sub>8</sub> "	36" 36"	<b>WCC113636</b>	\$650
18 <sup>7</sup> / <sub>8</sub> "	18 <sup>7</sup> / <sub>8</sub> "	42" 42"	<b>WCC114242</b>	\$691
18 <sup>7</sup> / <sub>8</sub> "	18 <sup>7</sup> / <sub>8</sub> "	48" 48"	<b>WCC114848</b>	\$772
18 <sup>7</sup> / <sub>8</sub> "	24"	42" 42"	<b>WCC124242</b>	\$743
24"	18 <sup>7</sup> / <sub>8</sub> "	42" 42"	<b>WCC214242</b>	\$743
24"	24"	36" 36"	<b>WCC223636</b>	\$657
24"	24"	42" 42"	<b>WCC224242</b>	\$717
24"	24"	48" 48"	<b>WCC224848</b>	\$797
30"	30"	42" 42"	<b>WCC334242</b>	\$776
30"	30"	48" 48"	<b>WCC334848</b>	\$868

Universal Systems  
Worksurfaces

# Extended Corner, Straight-Front Worksurfaces

High-Pressure Laminate

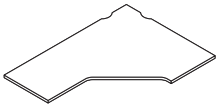

Tip: Illustration above shows a left-hand worksurface.

Tip: Supports must be specified separately, including side support brackets for rear corner support in panel-mounted applications.

Tip: Long worksurface spans require additional support.

▶ See understanding section for details, page 88

**For laminate group 2 and 3 pricing,** please refer to the electronic catalog or SmartTools.

Standard Includes		Required to Specify
▶ Need help? Product details, page 86	<ul style="list-style-type: none"> <li>• Worksurface: High-Pressure Laminate price group 1</li> <li>• Laminate worksurface:                             <ul style="list-style-type: none"> <li>–Plastic 3 mm edge profile on front edge</li> <li>–Plastic default flat profile on side and back edges</li> </ul> </li> <li>• Cable scallops on back edges</li> </ul>	<ol style="list-style-type: none"> <li>1 Style number</li> <li>2 High-Pressure Laminate number for worksurface</li> <li>3 Plastic color number for front edge on laminate worksurface</li> <li>4 Options, if selected (see below)</li> </ol> <p>▶ See <i>Surface Materials</i>, page 360.</p>

Options	U.S. Price	Required to Specify
<b>Surface Materials</b> <ul style="list-style-type: none"> <li>• High-Pressure Laminate worksurfaces</li> <li>• Laminate price group 2</li> <li>• Laminate price group 3</li> <li>• Open Line laminate</li> </ul>	<ul style="list-style-type: none"> <li>See information at left</li> <li>See information at left +\$102 plus cost of laminate</li> </ul>	<ul style="list-style-type: none"> <li>Specify laminate color number.</li> <li>Specify laminate color number.</li> </ul> <p>▶ See <i>Surface Materials Reference Manual</i>.</p>
<b>Scallops</b> <ul style="list-style-type: none"> <li>• Omit scallops</li> </ul>	No cost	Specify <i>omit scallops</i> .
<b>Related Products</b> <ul style="list-style-type: none"> <li>• Panel-mounted Universal Systems worksurface supports</li> <li>• Reinforcing channel</li> <li>• Legs and supports for Universal Systems Worksurfaces</li> </ul>		<ul style="list-style-type: none"> <li>▶ Page 262</li> <li>▶ Page 263</li> <li>▶ Page 266</li> </ul>



## For Canadian Pricing

Multiply U.S. Price by the Canadian price factor.

▶ See page 1 for details.

**Specification Information**

**U.S. Base Prices  
High-Pressure Laminate**



• Dimensions				• Style Number	• Plastic 3 mm Edge
A	B	C	D		

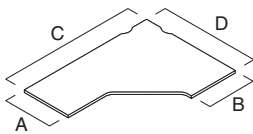

**Left-Hand With 1/2" Cord Drop**

23 1/2"	23 1/2"	59 1/2"	41 1/2"	<b>UE2202L</b>	\$1058
23 1/2"	23 1/2"	65 1/2"	41 1/2"	<b>UE2262L</b>	\$1158
23 1/2"	23 1/2"	71 1/2"	41 1/2"	<b>UE2222L</b>	\$1254
23 1/2"	23 1/2"	59 1/2"	47 1/2"	<b>UE2208L</b>	\$1088
23 1/2"	23 1/2"	65 1/2"	47 1/2"	<b>UE2268L</b>	\$1180
23 1/2"	23 1/2"	71 1/2"	47 1/2"	<b>UE2228L</b>	\$1274
23 1/2"	29 1/2"	59 1/2"	47 1/2"	<b>UE2308L</b>	\$1187
23 1/2"	29 1/2"	65 1/2"	47 1/2"	<b>UE2368L</b>	\$1282
23 1/2"	29 1/2"	71 1/2"	47 1/2"	<b>UE2328L</b>	\$1384
29 1/2"	23 1/2"	59 1/2"	47 1/2"	<b>UE3208L</b>	\$1187
29 1/2"	23 1/2"	65 1/2"	47 1/2"	<b>UE3268L</b>	\$1282
29 1/2"	23 1/2"	71 1/2"	47 1/2"	<b>UE3228L</b>	\$1384
29 1/2"	29 1/2"	59 1/2"	47 1/2"	<b>UE3308L</b>	\$1242
29 1/2"	29 1/2"	65 1/2"	47 1/2"	<b>UE3368L</b>	\$1343
29 1/2"	29 1/2"	71 1/2"	47 1/2"	<b>UE3328L</b>	\$1437

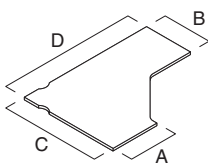

**Right-Hand With 1/2" Cord Drop**

23 1/2"	23 1/2"	41 1/2"	59 1/2"	<b>UE2220R</b>	\$1058
23 1/2"	23 1/2"	41 1/2"	65 1/2"	<b>UE2226R</b>	\$1158
23 1/2"	23 1/2"	41 1/2"	71 1/2"	<b>UE2222R</b>	\$1254
23 1/2"	23 1/2"	47 1/2"	59 1/2"	<b>UE2280R</b>	\$1088
23 1/2"	23 1/2"	47 1/2"	65 1/2"	<b>UE2286R</b>	\$1180
23 1/2"	23 1/2"	47 1/2"	71 1/2"	<b>UE2282R</b>	\$1274
23 1/2"	29 1/2"	47 1/2"	59 1/2"	<b>UE2380R</b>	\$1187
23 1/2"	29 1/2"	47 1/2"	65 1/2"	<b>UE2386R</b>	\$1282
23 1/2"	29 1/2"	47 1/2"	71 1/2"	<b>UE2382R</b>	\$1384
29 1/2"	23 1/2"	47 1/2"	59 1/2"	<b>UE3280R</b>	\$1187
29 1/2"	23 1/2"	47 1/2"	65 1/2"	<b>UE3286R</b>	\$1282
29 1/2"	23 1/2"	47 1/2"	71 1/2"	<b>UE3282R</b>	\$1384
29 1/2"	29 1/2"	47 1/2"	59 1/2"	<b>UE3380R</b>	\$1242
29 1/2"	29 1/2"	47 1/2"	65 1/2"	<b>UE3386R</b>	\$1343
29 1/2"	29 1/2"	47 1/2"	71 1/2"	<b>UE3382R</b>	\$1437

 **For Canadian Pricing**  
Multiply U.S. Price by the  
Canadian price factor.  
▶ See page 1 for details.

# Extended Corner, Curved-Front Worksurfaces

High-Pressure Laminate or Wood Veneer

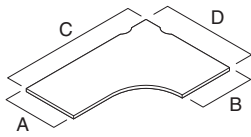

Left-Hand

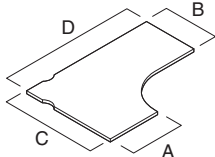

Right-Hand

*Tip: Supports must be specified separately, including side support brackets for rear corner support in panel-mounted applications.*

**For wood and laminate group 2 and 3 pricing,** please refer to the *electronic catalog* or *SmartTools*.

*Tip: Long work surface spans require additional support.*

▶ See *understanding* section for details, page 88

Standard Includes	Required to Specify
<ul style="list-style-type: none"> <li>▶ Need help? Product details, page 86</li> <li>• Worksurface: High-Pressure Laminate price group 1 or wood group 1 veneer</li> <li>• Laminate worksurface:                             <ul style="list-style-type: none"> <li>–Plastic 3 mm edge profile on front edge</li> <li>–Plastic default flat profile on side and back edges</li> </ul> </li> <li>• Wood worksurface:                             <ul style="list-style-type: none"> <li>–Wood 3 mm edge profile on front edge</li> <li>–Matching veneer flat profile on side and back edges</li> </ul> </li> <li>• Cable scallops on back edges</li> </ul>	<ol style="list-style-type: none"> <li>1 Style number with appropriate edge profile suffix                             <ul style="list-style-type: none"> <li>▶ <b>SW</b> Wood with square edge</li> <li>▶ See edge profiles below.</li> </ul> </li> <li>2 High-Pressure Laminate or wood color number for worksurface</li> <li>3 Plastic color number for front edge on laminate worksurface, if selected</li> <li>4 Options, if selected (see below)                             <ul style="list-style-type: none"> <li>▶ See <i>Surface Materials</i>, page 360.</li> </ul> </li> </ol>

Options	U.S. Price	Required to Specify
<b>Surface Materials</b> <ul style="list-style-type: none"> <li>• High-Pressure Laminate worksurfaces                             <ul style="list-style-type: none"> <li>• Laminate price group 2 See information at left</li> <li>• Laminate price group 3 See information at left</li> <li>• Open Line laminate +\$102 plus cost of laminate</li> </ul> </li> <li>• Wood veneer worksurfaces                             <ul style="list-style-type: none"> <li>• Wood group 2 See information at left</li> <li>• Wood group 3 See information at left</li> <li>• Customiz stain No cost</li> <li>• Full-fill finish on wood group 1 Prices at right</li> </ul> </li> </ul>		<ul style="list-style-type: none"> <li>Specify laminate color number.</li> <li>Specify laminate color number.</li> <li>▶ See <i>Surface Materials Reference Manual</i>.</li> <li>Specify wood color number.</li> <li>Specify wood color number.</li> <li>Specify <i>with Customiz stain</i>.</li> <li>▶ See <i>Surface Materials Reference Manual</i>.</li> <li>Specify full-fill finish number.</li> </ul>
<b>Scallops</b> <ul style="list-style-type: none"> <li>• Omit scallops</li> </ul>	No cost	Specify <i>omit scallops</i> .
<b>Related Products</b> <ul style="list-style-type: none"> <li>• Panel-mounted Universal Systems worksurface supports</li> <li>• Legs and supports for Universal Systems Worksurfaces</li> </ul>		<ul style="list-style-type: none"> <li>▶ Page 262</li> <li>▶ Page 266</li> </ul>





## For Canadian Pricing

Multiply U.S. Price by the Canadian price factor.

▶ See page 1 for details.

**Specification Information**

				U.S. Base Prices			U.S. Base Price		
				High-Pressure Laminate	Wood	High-Pressure Laminate			
									
Dimensions	Style	Plastic	Wood	Option	Dimensions	Style	Plastic		
A B C D	Number	3 mm Edge	Square Edge	(Add \$ to Base Price)	A B C D	Number	3 mm Edge		
		No Suffix	Suffix SW	Full-Fill Finish on Wood Group 1					

**Left-Hand With 1/2" Cord Drop**

23 1/2" 23 1/2" 59 1/2" 41 1/2"	<b>UEC2202L</b>	\$1058	\$2241	+\$ 93
23 1/2" 23 1/2" 65 1/2" 41 1/2"	<b>UEC2262L</b>	\$1158	\$2341	+\$113
23 1/2" 23 1/2" 71 1/2" 41 1/2"	<b>UEC2222L</b>	\$1254	\$2437	+\$114
23 1/2" 23 1/2" 59 1/2" 47 1/2"	<b>UEC2208L</b>	\$1088	\$2271	+\$113
23 1/2" 23 1/2" 65 1/2" 47 1/2"	<b>UEC2268L</b>	\$1180	\$2363	+\$114
23 1/2" 23 1/2" 71 1/2" 47 1/2"	<b>UEC2228L</b>	\$1274	\$2457	+\$120
23 1/2" 29 1/2" 59 1/2" 47 1/2"	<b>UEC2308L</b>	\$1187	\$2370	+\$114
23 1/2" 29 1/2" 65 1/2" 47 1/2"	<b>UEC2368L</b>	\$1282	\$2465	+\$120
23 1/2" 29 1/2" 71 1/2" 47 1/2"	<b>UEC2328L</b>	\$1384	\$2567	+\$122
29 1/2" 23 1/2" 59 1/2" 47 1/2"	<b>UEC3208L</b>	\$1187	\$2370	+\$114
29 1/2" 23 1/2" 65 1/2" 47 1/2"	<b>UEC3268L</b>	\$1282	\$2465	+\$120
29 1/2" 23 1/2" 71 1/2" 47 1/2"	<b>UEC3228L</b>	\$1384	\$2567	+\$122
29 1/2" 29 1/2" 59 1/2" 47 1/2"	<b>UEC3308L</b>	\$1242	\$2425	+\$120
29 1/2" 29 1/2" 65 1/2" 47 1/2"	<b>UEC3368L</b>	\$1343	\$2526	+\$122
29 1/2" 29 1/2" 71 1/2" 47 1/2"	<b>UEC3328L</b>	\$1437	\$2620	+\$125

**Right-Hand With 1/2" Cord Drop**

23 1/2" 23 1/2" 41 1/2" 59 1/2"	<b>UEC2220R</b>	\$1058	\$2241	+\$ 93
23 1/2" 23 1/2" 41 1/2" 65 1/2"	<b>UEC2226R</b>	\$1158	\$2341	+\$113
23 1/2" 23 1/2" 41 1/2" 71 1/2"	<b>UEC2222R</b>	\$1254	\$2437	+\$114
23 1/2" 23 1/2" 47 1/2" 59 1/2"	<b>UEC2280R</b>	\$1088	\$2271	+\$113
23 1/2" 23 1/2" 47 1/2" 65 1/2"	<b>UEC2286R</b>	\$1180	\$2363	+\$114
23 1/2" 23 1/2" 47 1/2" 71 1/2"	<b>UEC2282R</b>	\$1274	\$2457	+\$120
23 1/2" 29 1/2" 47 1/2" 59 1/2"	<b>UEC2380R</b>	\$1187	\$2370	+\$114
23 1/2" 29 1/2" 47 1/2" 65 1/2"	<b>UEC2386R</b>	\$1282	\$2465	+\$120
23 1/2" 29 1/2" 47 1/2" 71 1/2"	<b>UEC2382R</b>	\$1384	\$2567	+\$122
29 1/2" 23 1/2" 47 1/2" 59 1/2"	<b>UEC3280R</b>	\$1187	\$2370	+\$114
29 1/2" 23 1/2" 47 1/2" 65 1/2"	<b>UEC3286R</b>	\$1282	\$2465	+\$120
29 1/2" 23 1/2" 47 1/2" 71 1/2"	<b>UEC3282R</b>	\$1384	\$2567	+\$122
29 1/2" 29 1/2" 47 1/2" 59 1/2"	<b>UEC3380R</b>	\$1242	\$2425	+\$120
29 1/2" 29 1/2" 47 1/2" 65 1/2"	<b>UEC3386R</b>	\$1343	\$2526	+\$122
29 1/2" 29 1/2" 47 1/2" 71 1/2"	<b>UEC3382R</b>	\$1437	\$2620	+\$125

**With Full Depth**

24" 24" 60" 42"	<b>WEC226042</b>	\$1058
24" 24" 72" 42"	<b>WEC227242</b>	\$1254
24" 24" 60" 48"	<b>WEC226048</b>	\$1088
24" 24" 72" 48"	<b>WEC227248</b>	\$1274
24" 30" 60" 42"	<b>WEC236042</b>	\$1109
24" 30" 72" 42"	<b>WEC237242</b>	\$1315
24" 30" 60" 48"	<b>WEC236048</b>	\$1187
24" 30" 72" 48"	<b>WEC237248</b>	\$1384
30" 24" 60" 42"	<b>WEC326042</b>	\$1109
30" 24" 72" 42"	<b>WEC327242</b>	\$1315
30" 24" 60" 48"	<b>WEC326048</b>	\$1187
30" 24" 72" 48"	<b>WEC327248</b>	\$1384
30" 30" 60" 42"	<b>WEC336042</b>	\$1174
30" 30" 72" 42"	<b>WEC337242</b>	\$1366
30" 30" 60" 48"	<b>WEC336048</b>	\$1242
30" 30" 72" 48"	<b>WEC337248</b>	\$1437

**With Full Depth**

24" 24" 42" 60"	<b>WEC224260</b>	\$1058
24" 24" 42" 72"	<b>WEC224272</b>	\$1254
24" 24" 48" 60"	<b>WEC224860</b>	\$1088
24" 24" 48" 72"	<b>WEC224872</b>	\$1274
24" 30" 42" 60"	<b>WEC234260</b>	\$1109
24" 30" 42" 72"	<b>WEC234272</b>	\$1315
24" 30" 48" 60"	<b>WEC234860</b>	\$1187
24" 30" 48" 72"	<b>WEC234872</b>	\$1384
30" 24" 42" 60"	<b>WEC324260</b>	\$1109
30" 24" 42" 72"	<b>WEC324272</b>	\$1315
30" 24" 48" 60"	<b>WEC324860</b>	\$1187
30" 24" 48" 72"	<b>WEC324872</b>	\$1384
30" 30" 42" 60"	<b>WEC334260</b>	\$1174
30" 30" 42" 72"	<b>WEC334272</b>	\$1366
30" 30" 48" 60"	<b>WEC334860</b>	\$1242
30" 30" 48" 72"	<b>WEC334872</b>	\$1437

# Corner, 120° Worksurfaces

High-Pressure Laminate or Wood Veneer

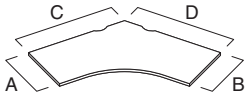

Tip: Supports must be specified separately, including side support brackets for rear corner support in panel-mounted applications.

Standard Includes	Required to Specify
<ul style="list-style-type: none"> <li>▶ Need help? Product details, page 86</li> <li>• Worksurface: High-Pressure Laminate price group 1 or wood group 1 veneer</li> <li>• Laminate worksurface:                             <ul style="list-style-type: none"> <li>–Plastic 3 mm edge profile on front edge</li> <li>–Plastic default flat profile on side and back edges</li> </ul> </li> <li>• Wood worksurface:                             <ul style="list-style-type: none"> <li>–Wood 3 mm edge profile on front edge</li> <li>–Matching veneer flat profile on side and back edges</li> </ul> </li> <li>• Cable scallops on back edges</li> </ul>	<ol style="list-style-type: none"> <li>1 Style number with appropriate edge profile suffix                             <ul style="list-style-type: none"> <li><b>SW</b> Wood with square edge</li> </ul> </li> <li>▶ See edge profiles below.</li> <li>2 High-Pressure Laminate or wood color number for worksurface</li> <li>3 Plastic color number for front edge on laminate worksurface, if selected</li> <li>4 Options, if selected (see below)                             <ul style="list-style-type: none"> <li>▶ See <i>Surface Materials</i>, page 360.</li> </ul> </li> </ol>

**For wood and laminate group 2 and 3 pricing,** please refer to the electronic catalog or SmartTools.

Tip: To specify 3 mm edge profile, no suffix is required. For all other edge profiles, add a suffix to the style number. (For example, UB223636 becomes UB223636SW for wood with square edge profile.)

Options	U.S. Price	Required to Specify
<b>Surface Materials</b> <ul style="list-style-type: none"> <li>• <b>High-Pressure Laminate worksurfaces</b> <ul style="list-style-type: none"> <li>• Laminate price group 2</li> <li>• Laminate price group 3</li> <li>• Open Line laminate</li> </ul> </li> <li>• <b>Wood veneer worksurfaces</b> <ul style="list-style-type: none"> <li>• Wood group 2</li> <li>• Wood group 3</li> <li>• Customiz stain</li> </ul> </li> <li>• Full-fill finish on wood group 1</li> </ul>	<ul style="list-style-type: none"> <li>See information at left</li> <li>See information at left +\$102 plus cost of laminate</li> <li>See information at left</li> <li>See information at left</li> <li>No cost</li> <li>Prices below</li> </ul>	<ul style="list-style-type: none"> <li>Specify laminate color number.</li> <li>Specify laminate color number.</li> <li>▶ See <i>Surface Materials Reference Manual</i>.</li> <li>Specify wood color number.</li> <li>Specify wood color number.</li> <li>Specify <i>with Customiz stain</i>.</li> <li>▶ See <i>Surface Materials Reference Manual</i>.</li> <li>Specify full-fill finish number.</li> </ul>
<b>Scallops</b> <ul style="list-style-type: none"> <li>• Omit scallops</li> </ul>	No cost	Specify <i>omit scallops</i> .
<b>Related</b> <ul style="list-style-type: none"> <li>• Panel-mounted Universal Systems worksurface supports</li> <li>• Legs and supports for Universal Systems Worksurfaces</li> </ul>		<ul style="list-style-type: none"> <li>▶ Page 262</li> <li>▶ Page 266</li> </ul>

Specification Information				U.S. Base Prices		Option (Add \$ to Base Price)
				High-Pressure Laminate	Wood	
• Dimensions	A	B	C	D	• Plastic 3 mm Edge	• Wood Square Edge
• Full-Fill Finish on Wood Group 1						

Freestanding or Panel-Mounted With 1/2" Cord Drop						
23 1/2"	23 1/2"	35 1/2"	35 1/2"	<b>UB223636</b>	\$1129	\$2209 +\$114
23 1/2"	23 1/2"	41 1/2"	41 1/2"	<b>UB224242</b>	\$1175	\$2255 +\$120
23 1/2"	23 1/2"	47 1/2"	47 1/2"	<b>UB224848</b>	\$1218	\$2298 +\$122
29 1/2"	29 1/2"	35 1/2"	35 1/2"	<b>UB333636</b>	\$1175	\$2255 +\$120
29 1/2"	29 1/2"	41 1/2"	41 1/2"	<b>UB334242</b>	\$1218	\$2298 +\$122
29 1/2"	29 1/2"	47 1/2"	47 1/2"	<b>UB334848</b>	\$1260	\$2340 +\$125



**For Canadian Pricing**  
Multiply U.S. Price by the Canadian price factor.  
▶ See page 1 for details.

# Spanner Worksurfaces

## High-Pressure Laminate or Wood Veneer

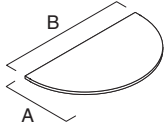

Tip: Supports for freestanding and panel-mounted applications must be specified separately.

Standard Includes		Required to Specify
<ul style="list-style-type: none"> <li>▶ Need help? Product details, page 86</li> </ul>	<ul style="list-style-type: none"> <li>• Worksurface: High-Pressure Laminate price group 1 or wood group 1 veneer</li> <li>• Laminate worksurface:                             <ul style="list-style-type: none"> <li>–Plastic 3 mm edge profile on front edge</li> <li>–Plastic default flat profile on side and back edges</li> </ul> </li> <li>• Wood worksurface:                             <ul style="list-style-type: none"> <li>–Wood 3 mm edge profile on front edge</li> <li>–Matching veneer flat profile on side and back edges</li> </ul> </li> </ul>	<ol style="list-style-type: none"> <li>1 Style number with appropriate edge profile suffix                             <ul style="list-style-type: none"> <li><b>SW</b> Wood with square edge</li> </ul> </li> <li>▶ See edge profiles below.</li> <li>2 High-Pressure Laminate or wood color number for worksurface</li> <li>3 Plastic color number for front edge on laminate worksurface, if selected</li> <li>4 Options, if selected (see below)</li> <li>▶ See <i>Surface Materials</i>, page 360.</li> </ol>

For wood and laminate group 2 and 3 pricing, please refer to the electronic catalog or SmartTools.

Tip: To specify 3 mm edge profile, no suffix is required. For all other edge profiles, add a suffix to the style number. (For example, USPC47 becomes USPC47SW for wood with square edge profile.)

Options	U.S. Price	Required to Specify
<b>Surface Materials</b> <ul style="list-style-type: none"> <li>• High-Pressure Laminate worksurfaces                             <ul style="list-style-type: none"> <li>• Laminate price group 2 See information at left</li> <li>• Laminate price group 3 See information at left</li> <li>• Open Line laminate +\$102 plus cost of laminate</li> </ul> </li> <li>• Wood veneer worksurfaces                             <ul style="list-style-type: none"> <li>• Wood group 2 See information at left</li> <li>• Wood group 3 See information at left</li> <li>• Customiz stain No cost</li> </ul> </li> <li>• Full-fill finish on wood group 1 Prices below</li> </ul>		Specify laminate color number. Specify laminate color number. ▶ See <i>Surface Materials Reference Manual</i> .
<b>Related Products</b> <ul style="list-style-type: none"> <li>• Panel-mounted Universal Systems worksurface supports</li> <li>• Legs and supports for Universal Systems Worksurfaces</li> <li>• Columns</li> </ul>		▶ Page 262 ▶ Page 266 ▶ Page 268

### Specification Information

U.S. Base Prices High-Pressure Laminate Wood					U.S. Base Price High-Pressure Laminate				
• Dimensions A B	• Style Number	• Plastic 3 mm Edge	• Wood Square Edge	• Option (Add \$ to Base Price)	• Dimensions A B	• Style Number	• Plastic 3 mm Edge		
		No Suffix	Suffix SW	Full-Fill Finish on Wood Group 1			• Plastic 3 mm Edge		

#### For Freestanding Applications without Panels With 1/2" Cord Drop

29 1/2"	47"	<b>USPC47</b>	\$629	\$1624	+\$88
35 1/2"	59"	<b>USPC59</b>	\$802	\$1797	+\$98

#### With Full Depth

24"	48"	<b>WSPC4824</b>	\$629
30"	60"	<b>WSPC6030</b>	\$802

**For Canadian Pricing**  
 Multiply U.S. Price by the Canadian price factor.  
 ▶ See page 1 for details.

# Bullet Peninsula Worksurfaces

High-Pressure Laminate or Wood Veneer

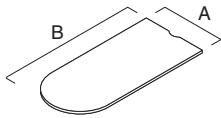

Tip: Supports for freestanding and panel-mounted applications must be specified separately.

Tip: Long work surface spans require additional support.  
▶ See understanding section for details, page 88

**For wood and laminate group 2 and 3 pricing,** please refer to the electronic catalog or SmartTools.



Tip: Bullet peninsula worksurfaces are recommended for use with other curved-front shapes such as corner, curved-front worksurfaces.  
▶ Page 245

Tip: The same bullet peninsula worksurfaces can be used with either worksurfaces with 1/2" cord drop or with full depth worksurfaces.

Tip: To specify 3 mm edge profile, no suffix is required. For all other edge profiles, add a suffix to the style number. (For example, UPBC3060 becomes UPBC3060SW for wood with square edge profile.)

Standard Includes	Required to Specify
<ul style="list-style-type: none"> <li>▶ Need help? Product details, page 86</li> <li>• Worksurface: High-Pressure Laminate price group 1 or wood group 1 veneer</li> <li>• Laminate worksurface:                             <ul style="list-style-type: none"> <li>–Plastic 3 mm edge profile on front edge</li> <li>–Plastic default flat profile on side and back edges</li> </ul> </li> <li>• Wood worksurface:                             <ul style="list-style-type: none"> <li>–Wood 3 mm edge profile on front edge</li> <li>–Matching veneer flat profile on side and back edges</li> </ul> </li> <li>• Cable scallop on back edge</li> </ul>	<ol style="list-style-type: none"> <li>1 Style number with appropriate edge profile suffix                             <ul style="list-style-type: none"> <li><b>SW</b> Wood with square edge</li> </ul> </li> <li>▶ See edge profiles below.</li> <li>2 High-Pressure Laminate or wood color number for worksurface</li> <li>3 Plastic color number for front edge on laminate worksurface, if selected</li> <li>4 Options, if selected (see below)                             <ul style="list-style-type: none"> <li>▶ See <i>Surface Materials</i>, page 360.</li> </ul> </li> </ol>

Options	U.S. Price	Required to Specify
<b>Surface Materials</b> <b>High-Pressure Laminate worksurfaces</b> <ul style="list-style-type: none"> <li>• Laminate price group 2</li> <li>• Laminate price group 3</li> <li>• Open Line laminate</li> </ul> <b>Wood veneer worksurfaces</b> <ul style="list-style-type: none"> <li>• Wood group 2</li> <li>• Wood group 3</li> <li>• Customiz stain</li> </ul> <ul style="list-style-type: none"> <li>• Full-fill finish on wood group 1</li> </ul>	See information at left See information at left +\$102 plus cost of laminate  See information at left See information at left No cost  Prices below	Specify laminate color number. Specify laminate color number. ▶ See <i>Surface Materials Reference Manual</i> .  Specify wood color number. Specify wood color number. Specify with <i>Customiz stain</i> . ▶ See <i>Surface Materials Reference Manual</i> . Specify full-fill finish number.
<b>Scallop</b> <ul style="list-style-type: none"> <li>• Omit scallop</li> </ul>	No cost	Specify <i>omit scallop</i> .
<b>Related Products</b> <ul style="list-style-type: none"> <li>• Panel-mounted Universal Systems worksurface supports</li> <li>• Legs and supports for Universal Systems Worksurfaces</li> <li>• Columns</li> </ul>		▶ Page 262 ▶ Page 266 ▶ Page 268

Dimensions		Style Number	U.S. Base Prices		Option
A	B		High-Pressure Laminate	Wood	
			 • Plastic 3 mm Edge • No Suffix	 • Wood Square Edge • Suffix SW	• Option • (Add \$ to Base Price) • Full-Fill Finish on Wood Group 1
24"	47½"	<b>UPBC2448</b>	\$736	N.A.	N.A.
24"	59½"	<b>UPBC2460</b>	\$748	N.A.	N.A.
24"	65½"	<b>UPBC2466</b>	\$771	N.A.	N.A.
24"	71½"	<b>UPBC2472</b>	\$787	N.A.	N.A.
30"	47½"	<b>UPBC3048</b>	\$855	N.A.	N.A.
30"	59½"	<b>UPBC3060</b>	\$872	\$1867	+\$85
30"	65½"	<b>UPBC3066</b>	\$889	\$1884	+\$87
30"	71½"	<b>UPBC3072</b>	\$908	\$1903	+\$93



**For Canadian Pricing**  
Multiply U.S. Price by the Canadian price factor.  
▶ See page 1 for details.

# Angled Peninsula Worksurfaces

High-Pressure Laminate

Angled Peninsula  
Worksurfaces

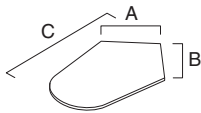

*Tip: Supports for freestanding and panel-mounted applications must be specified separately.*

**For laminate group 2 and 3 pricing, please refer to the electronic catalog or SmartTools.**

*Tip: To specify 3 mm edge profile, no suffix is required.*

Standard Includes		Required to Specify
<ul style="list-style-type: none"> <li>▶ Need help? Product details, page 86</li> </ul>	<ul style="list-style-type: none"> <li>• Worksurface: High-Pressure Laminate price group 1</li> <li>• Laminate worksurface:                             <ul style="list-style-type: none"> <li>–Plastic 3 mm edge profile on front edge</li> <li>–Plastic default flat profile on side and back edges</li> </ul> </li> </ul>	<ol style="list-style-type: none"> <li>1 Style number</li> <li>2 High-Pressure Laminate color number for worksurface</li> <li>3 Plastic color number for front edge on laminate worksurface</li> <li>4 Options, if selected (see below)</li> </ol> <p>▶ See <i>Surface Materials</i>, page 360.</p>

Options	U.S. Price	Required to Specify
<b>Surface Materials</b> <b>High-Pressure Laminate worksurfaces</b> <ul style="list-style-type: none"> <li>• Laminate price group 2</li> <li>• Laminate price group 3</li> <li>• Open Line laminate</li> </ul>	See information at left See information at left +\$102 plus cost of laminate	Specify laminate color number. Specify laminate color number. ▶ See <i>Surface Materials Reference Manual</i> .
<b>Related Products</b> <ul style="list-style-type: none"> <li>• Panel-mounted Universal Systems worksurface supports</li> <li>• Legs and supports for Universal Systems Worksurfaces</li> <li>• Columns</li> </ul>		▶ Page 262 ▶ Page 266 ▶ Page 268

Specification Information					
With 1/2" Cord Drop			With Full Depth		
Dimensions A B C	Style Number	U.S. Base Price High-Pressure Laminate	Dimensions A B C	Style Number	U.S. Base Price High-Pressure Laminate
23 1/2" 23 1/2" 48"	<b>UPA2448</b>	\$935	24" 24" 48"	<b>WPA2448</b>	\$935
23 1/2" 23 1/2" 60"	<b>UPA2460</b>	\$979	24" 24" 60"	<b>WPA2460</b>	\$979
29 1/2" 29 1/2" 48"	<b>UPA3048</b>	\$935	30" 30" 48"	<b>WPA3048</b>	\$935
29 1/2" 29 1/2" 60"	<b>UPA3060</b>	\$979	30" 30" 60"	<b>WPA3060</b>	\$979

 **For Canadian Pricing**  
 Multiply U.S. Price by the Canadian price factor.  
 ▶ See page 1 for details.

Universal Systems  
Worksurfaces

# Jetty Worksurfaces

High-Pressure Laminate or Wood Veneer

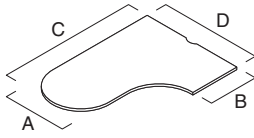

Tip: Supports for freestanding and panel-mounted applications must be specified separately.

Tip: Long worksurface spans require additional support.

▶ See understanding section for details, page 88

**For wood and laminate group 2 and 3 pricing,** please refer to the electronic catalog or SmartTools.

Tip: Jetty worksurfaces are recommended for use with other curved-front shapes such as corner, curved-front worksurfaces.

▶ Page 245

Tip: To specify 3 mm edge profile, no suffix is required. For all other edge profiles, add a suffix to the style number. (For example, UJC3268L becomes UJC3268LSW for wood with square edge profile.)

Standard Includes	Required to Specify
<ul style="list-style-type: none"> <li>▶ Need help? Product details, page 86</li> <li>• Worksurface: High-Pressure Laminate price group 1 or wood group 1 veneer</li> <li>• Laminate worksurface:                             <ul style="list-style-type: none"> <li>–Plastic 3 mm edge profile on front edge</li> <li>–Plastic default flat profile on side and back edges</li> </ul> </li> <li>• Wood worksurface:                             <ul style="list-style-type: none"> <li>–Wood 3 mm edge profile on front edge</li> <li>–Matching veneer flat profile on side and back edges</li> </ul> </li> <li>• Cable scallop on back edge</li> </ul>	<ol style="list-style-type: none"> <li>1 Style number with appropriate edge profile suffix                             <ul style="list-style-type: none"> <li>▶ <b>SW</b> Wood with square edge</li> <li>▶ See edge profiles below.</li> </ul> </li> <li>2 High-Pressure Laminate or wood color number for worksurface</li> <li>3 Plastic color number for front edge on laminate worksurface, if selected</li> <li>4 Options, if selected (see below)                             <ul style="list-style-type: none"> <li>▶ See <i>Surface Materials</i>, page 360.</li> </ul> </li> </ol>

Options	U.S. Price	Required to Specify
<p><b>Surface Materials</b></p> <p><b>High-Pressure Laminate worksurfaces</b></p> <ul style="list-style-type: none"> <li>• Laminate price group 2 See information at left</li> <li>• Laminate price group 3 See information at left</li> <li>• Open Line laminate +\$102 plus cost of laminate</li> </ul> <hr/> <p><b>Wood veneer worksurfaces</b></p> <ul style="list-style-type: none"> <li>• Wood group 2 See information at left</li> <li>• Wood group 3 See information at left</li> <li>• Customiz stain No cost</li> <li>• Full-fill finish on wood group 1 Prices at right</li> </ul>		<p>Specify laminate color number.</p> <p>Specify laminate color number.</p> <p>▶ See <i>Surface Materials Reference Manual</i>.</p> <hr/> <p>Specify wood color number.</p> <p>Specify wood color number.</p> <p>Specify <i>with Customiz stain</i>.</p> <p>▶ See <i>Surface Materials Reference Manual</i>.</p> <p>Specify full-fill finish number.</p>
<p><b>Scallop</b></p> <ul style="list-style-type: none"> <li>• Omit scallop</li> </ul>	No cost	Specify <i>omit scallop</i> .
<p><b>Related Products</b></p> <ul style="list-style-type: none"> <li>• Panel-mounted Universal Systems worksurface supports</li> <li>• Legs and supports for Universal Systems Worksurfaces</li> <li>• Columns</li> </ul>		<p>▶ Page 262</p> <p>▶ Page 266</p> <p>▶ Page 268</p>





## For Canadian Pricing

Multiply U.S. Price by the Canadian price factor.

▶ See page 1 for details.

**Specification Information**

				U.S. Base Prices				U.S. Base Price			
				High-Pressure Laminate	Wood	High-Pressure Laminate					
											
Dimensions	Style			Plastic	Wood	Option			Dimensions	Style	Plastic
A B C D	Number			3 mm	Square	(Add \$ to			A B C D	Number	3 mm
				Edge	Edge	Base Price)					Edge
				No Suffix	Suffix SW	Full-Fill					
						Finish on					
						Wood Group 1					

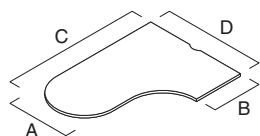

**Left-Hand With 1/2" Cord Drop**

30"	23 1/2"	65 1/2"	48"	<b>UJC3268L</b>	\$1239	\$2234	+\$113
30"	23 1/2"	71 1/2"	48"	<b>UJC3228L</b>	\$1282	\$2525	+\$119
30"	23 1/2"	77 1/2"	48"	<b>UJC3288L</b>	\$1325	\$2613	+\$125
30"	29 1/2"	65 1/2"	48"	<b>UJC3368L</b>	\$1281	\$2276	+\$113
30"	29 1/2"	71 1/2"	48"	<b>UJC3328L</b>	\$1325	\$2568	+\$119
30"	29 1/2"	77 1/2"	48"	<b>UJC3388L</b>	\$1370	\$2658	+\$125

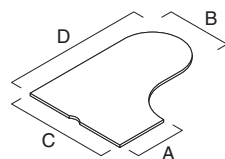

**Left-Hand With Full Depth**

30"	24"	66"	48"	<b>WJ326648L</b>	\$1239
30"	24"	72"	48"	<b>WJ327248L</b>	\$1282
30"	24"	78"	48"	<b>WJ327848L</b>	\$1325
30"	30"	66"	48"	<b>WJ336648L</b>	\$1281
30"	30"	72"	48"	<b>WJ337248L</b>	\$1325
30"	30"	78"	48"	<b>WJ337848L</b>	\$1370

**Right-Hand With 1/2" Cord Drop**

23 1/2"	30"	48"	65 1/2"	<b>UJC2386R</b>	\$1239	\$2234	+\$113
23 1/2"	30"	48"	71 1/2"	<b>UJC2382R</b>	\$1282	\$2525	+\$119
23 1/2"	30"	48"	77 1/2"	<b>UJC2388R</b>	\$1325	\$2613	+\$125
29 1/2"	30"	48"	65 1/2"	<b>UJC3386R</b>	\$1281	\$2276	+\$113
29 1/2"	30"	48"	71 1/2"	<b>UJC3382R</b>	\$1325	\$2568	+\$119
29 1/2"	30"	48"	77 1/2"	<b>UJC3388R</b>	\$1370	\$2658	+\$125

**Right-Hand With Full Depth**

24"	30"	48"	66"	<b>WJ234866R</b>	\$1239
24"	30"	48"	72"	<b>WJ234872R</b>	\$1282
24"	30"	48"	78"	<b>WJ234878R</b>	\$1325
30"	30"	48"	66"	<b>WJ334866R</b>	\$1281
30"	30"	48"	72"	<b>WJ334872R</b>	\$1325
30"	30"	48"	78"	<b>WJ334878R</b>	\$1370

*Tip: To specify 3 mm edge profile, no suffix is required. For all other edge profiles, add a suffix to the style number. (For example, UJC3268L becomes UJC3268LSW for wood with square edge profile.)*



**For Canadian Pricing**

Multiply U.S. Price by the Canadian price factor.

▶ See page 1 for details.

# Bubble Jetty Worksurfaces

High-Pressure Laminate or Wood Veneer

*Tip: Supports for freestanding and panel-mounted applications must be specified separately.*



Standard Includes	Required to Specify
<ul style="list-style-type: none"> <li>▶ Need help? Product details, page 86</li> <li>• Worksurface: High-Pressure Laminate price group 1 or wood group 1 veneer</li> <li>• Laminate worksurface:                             <ul style="list-style-type: none"> <li>–Plastic 3 mm edge profile on front edge</li> <li>–Plastic default flat profile on side and back edges</li> </ul> </li> <li>• Wood worksurface:                             <ul style="list-style-type: none"> <li>–Wood 3 mm edge profile on front edge</li> <li>–Matching veneer flat profile on side and back edges</li> </ul> </li> </ul>	<ol style="list-style-type: none"> <li>1 Style number with appropriate edge profile suffix                             <ul style="list-style-type: none"> <li><b>SW</b> Wood with square edge</li> </ul> </li> <li>▶ See edge profiles below.</li> <li>2 High-Pressure Laminate color number for worksurface</li> <li>3 Plastic color number for front edge</li> <li>4 Options, if selected (see below)</li> <li>▶ See <i>Surface Materials</i>, page 360.</li> </ol>

**For wood and laminate group 2 and 3 pricing, please refer to the electronic catalog or SmartTools.**

Options	U.S. Price	Required to Specify
<b>Surface Materials</b> <ul style="list-style-type: none"> <li>• High-Pressure Laminate worksurfaces                             <ul style="list-style-type: none"> <li>• Laminate price group 2</li> <li>• Laminate price group 3</li> <li>• Open Line laminate</li> </ul> </li> </ul>	See information at left See information at left +\$102 plus cost of laminate	Specify laminate color number. Specify laminate color number. ▶ See <i>Surface Materials Reference Manual</i> .
<ul style="list-style-type: none"> <li>• Wood veneer worksurfaces                             <ul style="list-style-type: none"> <li>• Wood group 2</li> <li>• Wood group 3</li> <li>• Customiz stain</li> </ul> </li> <li>• Full-fill finish on wood group 1</li> </ul>	See information at left See information at left No cost Prices below	Specify wood 2 color number. Specify wood 3 color number. Specify <i>with Customiz stain</i> . ▶ See <i>Surface Materials Reference Manual</i> . Specify full-fill finish number.
<b>Related Products</b> <ul style="list-style-type: none"> <li>• Panel-mounted Universal Systems worksurface supports</li> <li>• Legs and supports for Universal Systems Worksurfaces</li> <li>• Columns</li> </ul>		▶ Page 262 ▶ Page 266 ▶ Page 268

*Tip: To specify 3 mm edge profile, no suffix is required. For all other edge profiles, add a suffix to the style number. (For example, UJBC2430L becomes UJBC2430LSW for wood with square edge profile.)*

## Specification Information

Dimensions A B	Style Number	U.S. Base Prices		Option (Add \$ to Base Price) Full-Fill Finish on Wood Group 1
		High-Pressure Laminate	Wood	
		 • Plastic 3 mm Edge No Suffix	 • Wood Square Edge Suffix SW	

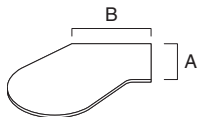

### Left-Hand With 1/2" Cord Drop

23 1/2" 30"	<b>UJBC2430L</b>	\$1164	\$2159	+\$59
23 1/2" 36"	<b>UJBC2436L</b>	\$1235	\$2230	+\$62
23 1/2" 42"	<b>UJBC2442L</b>	\$1309	\$2304	+\$78
23 1/2" 48"	<b>UJBC2448L</b>	\$1380	\$2375	+\$78

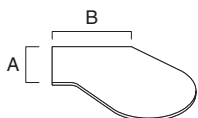

### Right-Hand With 1/2" Cord Drop

23 1/2" 30"	<b>UJBC2430R</b>	\$1164	\$2159	+\$59
23 1/2" 36"	<b>UJBC2436R</b>	\$1235	\$2230	+\$62
23 1/2" 42"	<b>UJBC2442R</b>	\$1309	\$2304	+\$78
23 1/2" 48"	<b>UJBC2448R</b>	\$1380	\$2375	+\$78



**For Canadian Pricing**  
 Multiply U.S. Price by the Canadian price factor.  
 ▶ See page 1 for details.



# Visitor Worksurfaces

High-Pressure Laminate or Wood Veneer

*Tip: Supports for freestanding and panel-mounted applications must be specified separately.*

*Tip: Visitor and linking worksurfaces are recommended for use with other curved-front shapes such as corner, curved-front worksurfaces.*

▶ Page 245



Standard Includes	Required to Specify
<ul style="list-style-type: none"> <li>▶ Need help? Product details, page 86</li> <li>• Worksurface: High-Pressure Laminate price group 1 or wood group 1 veneer</li> <li>• Laminate worksurface:                             <ul style="list-style-type: none"> <li>–Plastic 3 mm edge profile on front edge</li> <li>–Plastic default flat profile on side and back edges</li> </ul> </li> <li>• Wood worksurface:                             <ul style="list-style-type: none"> <li>–Wood 3 mm edge profile on front edge</li> <li>–Matching veneer flat profile on side and back edges</li> </ul> </li> <li>• Cable scallop on back edge of visitor worksurfaces 36"W and wider</li> </ul>	<ol style="list-style-type: none"> <li>1 Style number with appropriate edge profile suffix                             <ul style="list-style-type: none"> <li><b>SW</b> Wood with square edge</li> </ul> </li> <li>▶ See edge profiles at right.</li> <li>2 High-Pressure Laminate or wood color number for worksurface</li> <li>3 Plastic color number for front edge on laminate worksurface, if selected</li> <li>4 Options, if selected (see below)                             <ul style="list-style-type: none"> <li>▶ See <i>Surface Materials</i>, page 360.</li> </ul> </li> </ol>

**For wood and laminate group 2 and 3 pricing, please refer to the electronic catalog or SmartTools.**

*Tip: Scallops are available only on visitor worksurfaces 36"W and wider.*

Options	U.S. Price	Required to Specify
<b>Surface Materials</b> <ul style="list-style-type: none"> <li>• <b>High-Pressure Laminate worksurfaces</b> <ul style="list-style-type: none"> <li>• Laminate price group 2</li> <li>• Laminate price group 3</li> <li>• Open Line laminate</li> </ul> </li> <li>• <b>Wood veneer worksurfaces</b> <ul style="list-style-type: none"> <li>• Wood group 2</li> <li>• Wood group 3</li> <li>• Customiz stain</li> </ul> </li> <li>• Full-fill finish on wood group 1</li> </ul>	<ul style="list-style-type: none"> <li>See information at left</li> <li>See information at left</li> <li>+\$102 plus cost of laminate</li> <li>See information at left</li> <li>See information at left</li> <li>No cost</li> <li>Prices below and at right</li> <li>No cost</li> </ul>	<ul style="list-style-type: none"> <li>Specify laminate color number.</li> <li>Specify laminate color number.</li> <li>▶ See <i>Surface Materials Reference Manual</i>.</li> <li>Specify wood color number.</li> <li>Specify wood color number.</li> <li>Specify with <i>Customiz stain</i>.</li> <li>▶ See <i>Surface Materials Reference Manual</i>.</li> <li>Specify full-fill finish number.</li> <li>Specify <i>omit scallop</i>.</li> </ul>
<b>Scallop</b> <ul style="list-style-type: none"> <li>• Omit scallop</li> </ul>	No cost	Specify <i>omit scallop</i> .
<b>Related Products</b> <ul style="list-style-type: none"> <li>• Panel-mounted Universal Systems worksurface supports</li> <li>• Legs and supports for Universal Systems Worksurfaces</li> </ul>		<ul style="list-style-type: none"> <li>▶ Page 262</li> <li>▶ Page 266</li> </ul>

## Specification Information

U.S. Base Prices High-Pressure Laminate Wood				U.S. Base Price High-Pressure Laminate			
							
• Dimensions A B	• Style Number	• Plastic 3 mm Edge	• Wood Square Edge	• Options (Add \$ to Base Price)	• Dimensions A B	• Style Number	• Plastic 3 mm Edge
		No Suffix	Suffix SW	Full-Fill Finish on Wood Group 1			

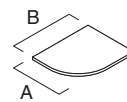
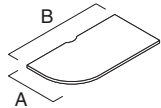

## Visitor Worksurfaces With 1/2" Cord Drop

### Left-Hand Worksurfaces

23 1/2"	24"	<b>UVC2424L</b>	\$605	\$1600	+\$55
23 1/2"	30"	<b>UVC2430L</b>	\$650	N.A.	N.A.
23 1/2"	36"	<b>UVC2436L</b>	\$695	N.A.	N.A.
23 1/2"	42"	<b>UVC2442L</b>	\$739	N.A.	N.A.
23 1/2"	48"	<b>UVC2448L</b>	\$777	N.A.	N.A.
29 1/2"	30"	<b>UVC3030L</b>	\$668	\$1687	+\$55

## With Full Depth



### Left-Hand Worksurfaces

24"	24"	<b>WVC2424L</b>	\$605
24"	30"	<b>WVC2430L</b>	\$650
30"	30"	<b>WVC3030L</b>	\$668

▶ **Specification Information, continued on next page**

► Specification Information, continued from previous page

**Specification Information**

			U.S. Base Prices High-Pressure Laminate Wood			U.S. Base Price High-Pressure Laminate		
								
• Dimensions	• Style		• Plastic	• Wood	• Options	• Dimensions	• Style	• Plastic
A B	Number		3 mm	Square	(Add \$ to	A B	Number	3 mm
			Edge	Edge	Base Price)			Edge
			No Suffix	Suffix SW	Full-Fill			
					Finish on			
					Wood Group 1			

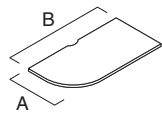

**Visitor Worksurfaces With 1/2" Cord Drop**

**Left-Hand Worksurfaces**

29 1/2"	36"	<b>UVC3036L</b>	\$717	N.A.	N.A.
29 1/2"	42"	<b>UVC3042L</b>	\$760	N.A.	N.A.
29 1/2"	48"	<b>UVC3048L</b>	\$806	N.A.	N.A.
:	:	:	:	:	:

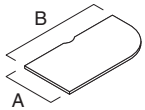

**Right-Hand Worksurfaces**

23 1/2"	24"	<b>UVC2424R</b>	\$605	\$1600	+\$55
23 1/2"	30"	<b>UVC2430R</b>	\$650	N.A.	N.A.
23 1/2"	36"	<b>UVC2436R</b>	\$695	N.A.	N.A.
23 1/2"	42"	<b>UVC2442R</b>	\$739	N.A.	N.A.
23 1/2"	48"	<b>UVC2448R</b>	\$777	N.A.	N.A.
29 1/2"	30"	<b>UVC3030R</b>	\$668	\$1687	+\$55
29 1/2"	36"	<b>UVC3036R</b>	\$717	N.A.	N.A.
29 1/2"	42"	<b>UVC3042R</b>	\$760	N.A.	N.A.
29 1/2"	48"	<b>UVC3048R</b>	\$806	N.A.	N.A.
:	:	:	:	:	:

**With Full Depth**

**Right-Hand Worksurfaces**

24"	24"	<b>WVC2424R</b>	\$605		
24"	30"	<b>WVC2430R</b>	\$650		
:	:	:	:	:	:
30"	30"	<b>WVC3030R</b>	\$668		
:	:	:	:	:	:

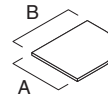

**For Canadian Pricing**

Multiply U.S. Price by the Canadian price factor.

► See page 1 for details.

# Power and Data Access Door & Tray

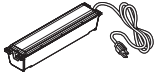

Tip: Remember to specify cutout for power and data tray on the worksurface style number.

Standard Includes		Required to Specify
<ul style="list-style-type: none"> <li>▶ Need help? Product details, page 94</li> </ul>	<ul style="list-style-type: none"> <li>• Door: paint</li> <li>• Door bezel: 6694 slate</li> <li>• Inner tray with six simplex receptacles: 7237 slate</li> <li>• Outer tray with end caps: 7237 slate and 6694 slate</li> <li>• Two cord clips or harness clips</li> </ul>	<ul style="list-style-type: none"> <li>1 Style number</li> <li>2 Paint color for door</li> <li>3 Options, if selected (see below)</li> <li>▶ See <i>Surface Materials</i>, page 360.</li> </ul>

Options	U.S. Price	Required to Specify
<b>Surface Materials</b> <ul style="list-style-type: none"> <li>• Paint</li> <li>• Anodized aluminum</li> </ul>	<b>Door</b> <ul style="list-style-type: none"> <li>No cost</li> <li>+\$34</li> </ul>	Specify paint color. Specify with 8043 clear anodized aluminum.

Specification Information			
Style Number	U.S. Base Price	Style Number Non-PVC	U.S. Base Price

Cord and Plug			
UTTRC	\$1574	UTTRCN	\$1589



**For Canadian Pricing**  
 Multiply U.S. Price by the Canadian price factor.  
 ▶ See page 1 for details.

## 2½" Round Grommet



Tip: Grommet AWAG2 is for use on worksurfaces only.

Tip: When using AWAG2 in the Universal parametric straight worksurface, specify the 2" grommet cutout option. Actual diameter of cutout is 2¼".

Standard Includes				Required to Specify	
<ul style="list-style-type: none"> <li>Grommet: paint or metal</li> <li>Installation instructions</li> </ul>				<ul style="list-style-type: none"> <li>1 Style number</li> <li>2 Paint or metal color number</li> </ul>	
▶ See <i>Surface Materials</i> , page 360.					
Specification Information					
Dimensions		Style	U.S.		
D	W	Number	Price		
2½"	2½"	<b>AWAG2</b>	\$100		

## 3" Grommet Package



Tip: When using TSAEGROM in the Universal parametric straight worksurface, specify the 3" grommet cutout.

Standard Includes		Required to Specify	
▶ Need help? Product details, page 52	<ul style="list-style-type: none"> <li>Package of 10 grommets: black plastic</li> </ul>	Style number	
Specification Information			
Style		U.S.	
Number		Price	
<b>TSAEGROM</b>		\$85	

 **For Canadian Pricing**  
Multiply U.S. Price by the Canadian price factor.  
▶ See page 1 for details.

# Panel-Mounted Universal Systems Worksurface Supports

For Use with Kick Panels

## Cantilevers

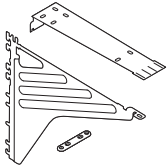

*Tip: Kick panels can accommodate only one cantilever at a seam.*

*Tip: 30"D straight and transition cantilevered worksurfaces require additional floor support along the front edge, such as a pedestal, end panel, post leg, side support bracket, or an adjacent return worksurface.*

Standard Includes	Required to Specify
<ul style="list-style-type: none"> <li>▶ Need help? Product details, page 100</li> <li>• Cantilever: paint</li> <li>• Tie plate</li> <li>• Attachment hardware</li> </ul>	<ul style="list-style-type: none"> <li>1 Style number</li> <li>2 Paint color number for cantilever</li> <li>▶ See <i>Surface Materials</i>, page 360.</li> </ul>

### Specification Information

Style Number	U.S. Price

### On-Module Cantilever

<b>UCANT</b>	\$162

## Side Support Brackets



*Tip: Side support bracket includes a pair of handed brackets, only one of which is required for rear corner support of panel-mounted corner worksurfaces. Specify one for every two corner worksurfaces in on-module applications. Order an additional supply for off-module fin wall applications.*

Standard Includes	Required to Specify
<ul style="list-style-type: none"> <li>▶ Need help? Product details, page 100</li> <li>• Pair of handed side support brackets: black paint only</li> <li>• Attachment hardware</li> </ul>	<ul style="list-style-type: none"> <li>Style number</li> </ul>

### Specification Information

Style Number	U.S. Price

<b>USSBR</b>	\$58



### For Canadian Pricing

Multiply U.S. Price by the Canadian price factor.

▶ See page 1 for details.

## Support Plate

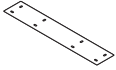

Tip: Support plate can also be used in freestanding applications.

Standard Includes		Required to Specify
▶ Need help? Product details, page 102	<ul style="list-style-type: none"> <li>Support plate: black paint only</li> <li>Attachment hardware</li> </ul>	Style number

Specification Information		
Dimensions	Style Number	U.S. Price
14"D	<b>TS714WSP</b>	\$109
20"D	<b>TS720WSP</b>	\$109
:	:	:

## Tie Plates



Standard Includes		Required to Specify
	<ul style="list-style-type: none"> <li>Package of six tie plates: black paint only</li> <li>Attachment hardware</li> </ul>	Style number

Specification Information		
Dimensions	Style Number	U.S. Price
3¾"L	<b>TS7TIEPLATE</b>	\$158
:	:	:

## Reinforcing Channels

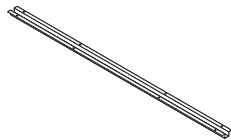

Tip: Reinforcing channel can also be used in freestanding applications.

Standard Includes		Required to Specify
▶ Need help? Product details, page 90	<ul style="list-style-type: none"> <li>Reinforcing channel: black paint only</li> <li>Attachment hardware</li> </ul>	Style number

Specification Information		
Dimensions	Style Number	U.S. Price
39"W	<b>TS7WKSPT39</b>	\$76
48"W	<b>TS7WKSPT48</b>	\$76
51"W	<b>TS7WKSPT51</b>	\$76
54"W	<b>TS7WKSPT54</b>	\$76
57"W	<b>TS7WKSPT</b>	\$76
60"W	<b>TS7WKSPT60</b>	\$76
63"W	<b>TS7WKSPT63</b>	\$76
66"W	<b>TS7WKSPT66</b>	\$76
72"W	<b>TS7WKSPT72</b>	\$76
:	:	:

 **For Canadian Pricing**  
Multiply U.S. Price by the Canadian price factor.  
▶ See page 1 for details.

## Center Support Panels

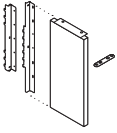

Standard Includes		Required to Specify
<ul style="list-style-type: none"> <li>▶ Need help? Product details, page 100</li> </ul>	<ul style="list-style-type: none"> <li>Center support panel: paint price group 1</li> <li>Tie plate</li> <li>Attachment hardware</li> </ul>	<ul style="list-style-type: none"> <li>1 Style number</li> <li>2 Paint color number for center support panel</li> <li>3 Options, if selected (see below)</li> <li>▶ See <i>Surface Materials</i>, page 360.</li> </ul>

Options	U.S. Price	Required to Specify
<b>Surface Materials</b> <ul style="list-style-type: none"> <li>Paint price group 1</li> <li>Paint price group 2</li> <li>Paint price group 3</li> </ul>	No cost +\$19 +\$33	Specify paint color number. Specify paint color number. Specify paint color number.

Specification Information			
Dimensions		Style	U.S.
D	H	Number	Base Price
<b>On-Module Center Support Panel</b>			
11"	28½"	<b>UCSP</b>	\$210
<b>Standing Height</b>			
11"	40⅞"	<b>UCSPS</b>	\$245

## End Panels

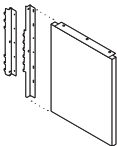

Standard Includes		Required to Specify
<ul style="list-style-type: none"> <li>▶ Need help? Product details, page 100</li> </ul>	<ul style="list-style-type: none"> <li>End panel: paint price group 1</li> <li>Attachment hardware</li> </ul>	<ul style="list-style-type: none"> <li>1 Style number</li> <li>2 Paint color number for end panel</li> <li>3 Options, if selected (see below)</li> <li>▶ See <i>Surface Materials</i>, page 360.</li> </ul>

Options	U.S. Price	Required to Specify
<b>Surface Materials</b> <ul style="list-style-type: none"> <li>Paint price group 1</li> <li>Paint price group 2</li> <li>Paint price group 3</li> </ul>	No cost +\$45 +\$74	Specify paint color number. Specify paint color number. Specify paint color number.

Specification Information			
Dimensions		Style	U.S.
D	H	Number	Base Price
<b>On-Module End Panel</b>			
24"	28½"	<b>UEP24</b>	\$574
30"	28½"	<b>UEP30</b>	\$653
<b>Standing Height</b>			
24"	40⅞"	<b>UEP24S</b>	\$679
30"	40⅞"	<b>UEP30S</b>	\$762



**For Canadian Pricing**  
 Multiply U.S. Price by the Canadian price factor.  
 ▶ See page 1 for details.



# Legs and Columns for Universal Systems Worksurfaces

Without Alignment Tab

## Post Legs and Double Post Legs

*Tip: Height dimensions listed are nominal and include the thickness of a worksurface.*

*Tip: Standing height legs can be used as column support in panel-mounted applications only.*

*Tip: Corner worksurfaces require a leg in the back corner. Be sure to order fifth leg if specifying a package of four.*

Standard Includes	Required to Specify
-------------------	---------------------

- |  |   |   |
|--|---|---|
| <ul style="list-style-type: none"> <li>▶ Need help? Product details, page 102</li> </ul> | <ul style="list-style-type: none"> <li>• Legs: paint</li> <li>• Attachment hardware</li> <li>• Non-locking caster, if selected: black plastic only</li> </ul> | <ul style="list-style-type: none"> <li>1 Style number</li> <li>2 Paint color number for leg</li> <li>3 Options, if selected (see below)</li> <li>▶ See <i>Surface Materials</i>, page 360.</li> </ul> |
|--|---|---|

Options	U.S. Price	Required to Specify
---------	------------	---------------------

- |  |   |   |
|--|---|---|
| <b>Surface Materials</b> <ul style="list-style-type: none"> <li>• Paint price group 1</li> <li>• Paint price group 2</li> <li>• Paint price group 3</li> </ul> | No cost<br>+\$29 per leg<br>+\$51 per leg | Specify paint color number.<br>Specify paint color number.<br>Specify paint color number. |
|--|---|---|

### Specification Information

Planning Height	Style Number	U.S. Base Price	Planning Height	Style Number	U.S. Base Price
-----------------	--------------	-----------------	-----------------	--------------	-----------------

#### Post Leg with Glide

26"	<b>UNPL</b>	\$190
28½"	<b>UPL</b>	\$190
40⅞"	<b>UHPL</b>	\$239
:	:	:

#### Package of Four Post Legs with Glides

26"	<b>UNPL4</b>	\$760
28½"	<b>UPL4</b>	\$760
:	:	:

#### Post Leg with Caster

26"	<b>UNPLC</b>	\$216
28½"	<b>UPLC</b>	\$216
:	:	:

#### Package of Four Post Legs with Casters

26"	<b>UNPL4C</b>	\$864
28½"	<b>UPL4C</b>	\$864
:	:	:

#### Package of Four Post Legs with Two Glides and Two Casters

26"	<b>UNPL4M</b>	\$812
28½"	<b>UPL4M</b>	\$812
:	:	:

▶ **Specification Information, continued on next page**

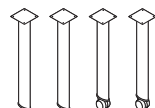

**For Canadian Pricing**  
 Multiply U.S. Price by the Canadian price factor.  
 ▶ See page 1 for details.

► **Specification Information, continued from previous page**

**Specification Information**

• Planning Height	• Style Number	• U.S. Base Price
----------------------	-------------------	-------------------------

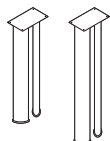

*Tip: Double post legs can be used as a shared or column support in applications with other post legs.*

**Double Post Leg with Glides**

28½"	<b>UDPL</b>	\$533
40⅞"	<b>UHDPL</b>	\$626
:	:	:

**Double Post C-Leg with Glides**

28½"	<b>UCL</b>	\$606
:	:	:

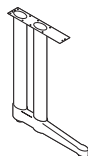

**For Canadian Pricing**

Multiply U.S. Price by the Canadian price factor.

► See page 1 for details.

## Adjustable-Height Legs

*Tip: Corner worksurfaces require a leg in the back corner. Be sure to order fifth leg if specifying a package of four.*

*Tip: Height dimensions listed include the thickness of a worksurface.*

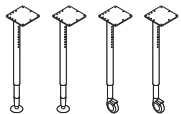

Standard Includes		Required to Specify
▶ Need help? Product details, page 102	<ul style="list-style-type: none"> <li>• Worksurface legs: paint</li> <li>• Glides, if selected: paint to match legs</li> <li>• Locking casters, if selected: paint to match legs</li> <li>• Attachment hardware</li> </ul>	1 Style number 2 Paint color number for leg 3 Options, if selected (see below) ▶ See <i>Surface Materials</i> , page 360.

Options	U.S. Price	Required to Specify
<b>Surface Materials</b>	<ul style="list-style-type: none"> <li>• Paint price group 1</li> <li>• Paint price group 2</li> </ul>	No cost +\$29 per leg Specify paint color number. Specify paint color number.

### Specification Information

Planning Height	Style Number	U.S. Base Price	Planning Height	Style Number	U.S. Base Price
-----------------	--------------	-----------------	-----------------	--------------	-----------------

Adjustable-Height Leg with Glide			Package of Four Adjustable-Height Legs with Glides		
25½"–31½"	UADJ	\$312	25½"–31½"	UADJ4	\$1248

Adjustable-Height Leg with Caster			Package of Four Adjustable-Height Legs with Casters		
25½"–31½"	UADJC	\$349	25½"–31½"	UADJ4C	\$1396

Package of Four Adjustable-Height Legs with Two Glides and Two Casters					
25½"–31½"	UADJ4M	\$1322			

## Columns

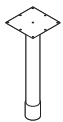

*Tip: Columns have a different aesthetic than post legs (round vs. elliptical). Columns can be used as column supports in applications without post legs.*

*Tip: Height dimensions listed include the thickness of a worksurface.*



**For Canadian Pricing**  
 Multiply U.S. Price by the Canadian price factor.  
 ▶ See page 1 for details.

Standard Includes		Required to Specify
▶ Need help? Product details, page 102	<ul style="list-style-type: none"> <li>• Column: paint</li> <li>• Attachment hardware</li> </ul>	1 Style number 2 Paint color number for column 3 Options, if selected (see below) ▶ See <i>Surface Materials</i> , page 360.

Options	U.S. Price	Required to Specify
<b>Surface Materials</b>	<ul style="list-style-type: none"> <li>• Paint price group 1</li> <li>• Paint price group 2</li> <li>• Paint price group 3</li> </ul>	No cost +\$29 per leg +\$51 per leg Specify paint color number. Specify paint color number. Specify paint color number.

### Specification Information

Planning Height	Style Number	U.S. Base Price
-----------------	--------------	-----------------

28½"	UCOL	\$420
28½"–31⅝"	UADJCOL	\$517



*Tip: The Divisio side screen can be used on any 3/4"- to 1 1/2"-thick worksurface.*

*Tip: The Divisio side screen has an overhang of 8". This is important when planning for returns or storage.*

*Tip: The Divisio side screen weighs approximately 14 1/2 pounds. Take this into consideration when planning for use on height-adjustable worksurfaces.*

*Tip: The Divisio side screen is intended for use on the front of a worksurface.*

*Tip: The Divisio side screen does not work on knife edge profiles.*

Standard Includes		Required to Specify
▶ Need help? Product details, page 108	<ul style="list-style-type: none"> <li>• Screen: fabric price group A</li> <li>• Top cap and clamp: 4799 Platinum paint</li> </ul>	1 Style number 2 Fabric color number ▶ See <i>Surface Materials Reference Manual</i> .

Options	U.S. Price	Required to Specify
<b>Surface Materials</b> <b>Fabric</b> <ul style="list-style-type: none"> <li>• Fabric price group A</li> <li>• Fabric price group 1</li> <li>• Fabric price group 2</li> <li>• Customer's Own Material (COM)</li> </ul>	No cost No cost +\$21 +\$23	Specify fabric color number. Specify fabric color number. Specify fabric color number. ▶ See <i>Surface Materials Reference Manual</i> .

Specification Information			
Dimensions		Style	U.S.
D	H	Number	Base Price
29 1/2"	11 5/8"	<b>DVSS2912</b>	\$509



**For Canadian Pricing**

Multiply U.S. Price by the Canadian price factor.

▶ See page 1 for details.



---

# TS Series Storage

<b>TS Series Fixed Pedestals</b>	<b>272</b>
<b>TS Series Fixed Pedestal Accessories</b>	<b>273</b>
<b>TS Series Mobile Pedestals</b>	<b>274</b>
<b>TS Series Mobile Pedestal Accessories</b>	<b>276</b>
<b>TS Series Bins</b>	<b>277</b>
<b>TS Series Laminate Common Shelves</b>	<b>279</b>
<b>TS Series Under-Worksurface Lateral Files</b>	<b>280</b>
<b>TS Series Freestanding Lateral Files</b>	<b>281</b>
<b>TS Series Lateral File Accessories</b>	<b>282</b>
<b>TS Series Tower Too</b>	<b>284</b>

# TS Series Fixed Pedestals

Tip: TS Series fixed pedestals are only intended for use under a panel mounted worksurface and can not be used as freestanding.

▶ See Counterweight Requirements for Storage Products, page 111.

Tip: TS Series fixed pedestals are only intended for use under a panel-mounted worksurface or with a free-standing desk; they cannot be used as freestanding.

Tip: File drawer rails are required to file legal-sized files or side-to-side letter-sized files in pedestal file drawers.

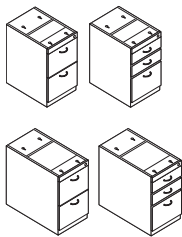

Standard Includes		Required to Specify
▶ Need help? Product details, page 122	<ul style="list-style-type: none"> <li>• Pedestal: paint price group 1</li> <li>• Pulls: metal</li> <li>• Lock face ring with plastic plug to accommodate lock cylinder: 9201 Polished Chrome</li> <li>• Attachment hardware</li> <li>• Steel ball-bearing suspensions on box and file drawers</li> <li>• Adjustable glides: black plastic</li> </ul>	1 Style number 2 Paint color number for pedestal 3 Pull (see below under required selections) 4 Options, if selected (see below) ▶ See <i>Surface Materials</i> , page 360. <i>Tip: Remember to specify lock cylinder and key.</i> ▶ <i>Lock Cylinders</i> , page 374

## Required Selections

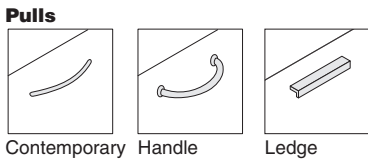

Options	U.S. Price	Required to Specify
<b>Surface Materials</b> <ul style="list-style-type: none"> <li>• Paint price group 1</li> <li>• Paint price group 2</li> <li>• Paint price group 3</li> </ul>	No cost +\$12 +\$28	Specify paint color number. Specify paint color number. Specify paint color number.
<b>Pulls</b> <ul style="list-style-type: none"> <li>• Contemporary pulls</li> <li>• Handle pulls</li> <li>• Ledge pulls: 7207 Black</li> <li>• Ledge pulls: 4799 Platinum</li> </ul>	No cost No cost No cost +\$ 7	Specify with contemporary pulls. Specify with handle pulls. Specify with 7207 Black ledge pulls. Specify with 4799 Platinum ledge pulls.
<b>Drawer Accessories</b> <ul style="list-style-type: none"> <li>• Filing rail (package of 2)</li> <li>• Box drawer dividers (package of 2)</li> <li>• File drawer dividers (package of 2)</li> <li>• Pencil tray</li> </ul>	+\$26 +\$37 +\$37 +\$26	Specify with filing rail. Specify with box drawer dividers. Specify with file drawer dividers. Specify with pencil tray.

## Specification Information

Dimensions			File Drawers	Counterweight Package	Style Number	U.S. Base Price
D	W	H				
22"	15"	27"	File, File	Available	<b>TS2PFF22U</b>	\$647
22"	15"	27"	Box, Box, File	Available	<b>TS2PBBF22U</b>	\$682
28"	15"	27"	File, File	Available	<b>TS2PFF28U</b>	\$703
28"	15"	27"	Box, Box, File	Available	<b>TS2PBBF28U</b>	\$742

## Pedestal Filler

For Use with Under-Worksurface Pedestal to Attach to Kick Panel System



Tip: When using a pedestal to anchor the end of a panel run, you must use a pedestal filler.

Standard Includes		Required to Specify
▶ Need help? Product details, page 123	<ul style="list-style-type: none"> <li>• Filler: paint</li> <li>• Attachment hardware</li> </ul>	1 Style number 2 Paint color number ▶ See <i>Surface Materials</i> , page 360.

## Specification Information

Dimensions			Style Number	U.S. Price
D	W	H		
2 <sup>3</sup> / <sub>16</sub> "	1"	27"	<b>TS2FILLER</b>	\$83

## Rails

For Use in Fixed Pedestals

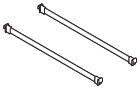

*Tip: Two rails per drawer accommodate side-to-side filing of letter-, A4-, and legal-size hanging folders. Exception: Legal-size file folders cannot be filed in 18"D pedestals.*

Standard Includes	Required to Specify
<ul style="list-style-type: none"> <li>▶ Need help? Product details, page 123</li> <li>• Package of two rails: black only</li> </ul>	Style number

Specification Information		
Width	Style Number	U.S. Price
12"	<b>RXADRL15</b>	\$37

## Dividers

For Use in Fixed Pedestals



Standard Includes	Required to Specify
<ul style="list-style-type: none"> <li>▶ Need help? Product details, page 123</li> <li>• Package of dividers: black only</li> </ul>	Style number

Specification Information			
Width	Quantity	Style Number	U.S. Price

### For Use in 6"H Drawers

12"	2	<b>RDV1506</b>	\$ 59
-----	---	----------------	-------

### For Use in 12"H Drawers

12"	2	<b>RDV1512</b>	\$ 63
12"	10	<b>RDV151210</b>	\$296

## Pencil Tray

For Use in Fixed Pedestals

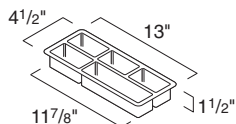

*Tip: Pencil trays for use with fixed pedestals are available as optional accessories.*



**For Canadian Pricing**  
Multiply U.S. Price by the Canadian price factor.  
▶ See page 1 for details.

Standard Includes	Required to Specify
<ul style="list-style-type: none"> <li>▶ Need help? Product details, page 123</li> <li>• Pencil tray: black only</li> </ul>	Style number

Specification Information	
Style Number	U.S. Price
<b>RPXDPT</b>	\$51

# TS Series Mobile Pedestals

With Steel Top

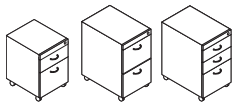

*Tip: Counterweight packages for mobile pedestals are required to ensure product stability and are included.*

▶ See *Counterweight Requirements for Storage Products*, page 111.

Standard Includes		Required to Specify
▶ Need help? Product details, page 122	<ul style="list-style-type: none"> <li>• Pedestal: paint price group 1</li> <li>• Pulls: metal</li> <li>• Lock face ring with plastic plug to accommodate lock cylinder: 9201 Polished Chrome</li> <li>• Steel ball-bearing suspensions on box and file drawers</li> <li>• 1½"-diameter, front-locking, hard casters</li> <li>• Counterweight package</li> </ul>	<ol style="list-style-type: none"> <li>1 Style number</li> <li>2 Paint color number for pedestal</li> <li>3 Pull (see below under required selections)</li> <li>4 Options, if selected (see below)</li> </ol> <p>▶ See <i>Surface Materials</i>, page 360.</p> <p><i>Tip: Remember to specify lock cylinder and key.</i></p> <p>▶ <i>Lock Cylinders</i>, page 374</p>

## Required Selections

### Pulls

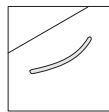

Contemporary

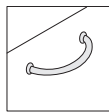

Handle

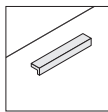

Ledge

	Options	U.S. Price	Required to Specify
<b>Surface Materials</b>	<ul style="list-style-type: none"> <li>• Paint price group 1</li> <li>• Paint price group 2</li> <li>• Paint price group 3</li> </ul>	No cost +\$12 +\$28	Specify paint color number. Specify paint color number. Specify paint color number.
<b>Pulls</b>	<ul style="list-style-type: none"> <li>• Contemporary pulls</li> <li>• Handle pulls</li> <li>• Ledge pulls: 7207 Black</li> <li>• Ledge pulls: 4799 Platinum</li> </ul>	No cost No cost No cost +\$ 7	Specify with <i>contemporary pulls</i> . Specify with <i>handle pulls</i> . Specify with <i>7207 Black ledge pulls</i> . Specify with <i>4799 Platinum ledge pulls</i> .
<b>Trim Strip Handle Pull</b>	<ul style="list-style-type: none"> <li>• Extra handle pull on trim strip of mobile pedestals only</li> </ul>	+ \$52	Specify with <i>extra handle pull on trim strip</i> .
<b>Related Products</b>	<ul style="list-style-type: none"> <li>• Box drawer divider</li> <li>• File drawer divider</li> <li>• Pencil tray</li> </ul>		▶ Page 276 ▶ Page 276 ▶ Page 276

## Specification Information

Dimensions			File Drawers	Counterweight Package	Style Number	U.S. Base Price
D	W	H				
19"	15¼"	21"	Box, File	Included	<b>TS2PBF19M</b>	\$652
22"	15¼"	21"	Box, File	Included	<b>TS2PBF22M</b>	\$677
22"	15¼"	26⅝"	File, File	Included	<b>TS2PFF22M</b>	\$765
22"	15¼"	26⅝"	Box, Box, File	Included	<b>TS2PBBF22M</b>	\$843



### For Canadian Pricing

Multiply U.S. Price by the Canadian price factor.

▶ See page 1 for details.

# TS Series Mobile Pedestals

With Seat Cushion

*Tip: Counterweight packages for mobile pedestals are required to ensure product stability and are included.*

▶ See *Counterweight Requirements for Storage Products*, page 111.

Standard Includes		Required to Specify
▶ Need help? Product details, page 122	<ul style="list-style-type: none"> <li>• Pedestal: paint price group 1</li> <li>• Seat cushion: fabric price group 1</li> <li>• Pulls: metal</li> <li>• Lock face ring with plastic plug to accommodate lock cylinder: 9201 Polished Chrome</li> <li>• Handle on pedestal with seat cushion and handle, if selected: 0835 Black</li> <li>• Steel ball-bearing suspensions on box and file drawers</li> <li>• 1½"-diameter front-locking, hard casters</li> <li>• Counterweight package</li> </ul>	<ol style="list-style-type: none"> <li>1 Style number</li> <li>2 Fabric color number for seat cushion</li> <li>3 Paint color number for pedestal</li> <li>4 Pull (see below under required selections)</li> <li>5 Options, if selected (see below)</li> </ol> <p>▶ See <i>Surface Materials</i>, page 360.</p> <p><i>Tip: Remember to specify lock cylinder and key.</i></p> <p>▶ <i>Lock Cylinders</i>, page 374</p>

## Required Selections

**Pulls**

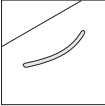

Contemporary

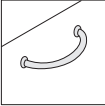

Handle

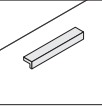

Ledge

Options	U.S. Price	Required to Specify
<b>Surface Materials</b>		
<b>Pedestal</b>		
• Paint price group 1	No cost	Specify paint color number.
• Paint price group 2	+\$ 12	Specify paint color number.
• Paint price group 3	+\$ 28	Specify paint color number.
<b>Seat cushion</b>		
• Fabric price group 1	No cost	Specify fabric color number.
• Fabric price group 2	+\$ 7	Specify fabric color number.
• Fabric price group 3	+\$ 21	Specify fabric color number.
• Fabric price group 4	+\$ 36	Specify fabric color number.
• Fabric price group 5	+\$ 46	Specify fabric color number.
• Fabric price group 6	+\$ 55	Specify fabric color number.
• Fabric price group 7	+\$ 62	Specify fabric color number.
• Fabric price group 8	+\$ 80	Specify fabric color number.
• Fabric price group 9	+\$101	Specify fabric color number.
• Fabric price group 10	+\$113	Specify fabric color number.
• Customer's Own Material	+\$ 23	▶ See <i>Surface Materials Reference Manual</i> .
<b>Pulls</b>		
• Contemporary pulls	No cost	Specify with contemporary pulls.
• Handle pulls	No cost	Specify with handle pulls.
• Ledge pulls: 7207 Black	No cost	Specify with 7207 Black ledge pulls.
• Ledge pulls: 4799 Platinum	+\$ 7	Specify with 4799 Platinum ledge pulls.
<b>Trim Strip Handle Pull</b>	+\$ 52	Specify with extra handle pull on trim strip.
<b>Related Products</b>		
• Box drawer divider		▶ Page 276
• File drawer divider		▶ Page 276
• Pencil tray		▶ Page 276

## Specification Information

Dimensions			File Drawers	Counterweight Package	Style Number	U.S. Base Price
D	W	H				

Mobile Pedestal with Seat Cushion						
22¼"	15½"	22¾"	Box, File	Included	<b>TS2PBF22MC</b>	\$ 962

Mobile Pedestal with Seat Cushion and Handle						
22½"	16¼"	22¾"	Box, File	Included	<b>TS2PBF22MCH</b>	\$1033

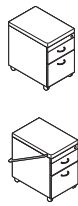

TS Series Storage

# TS Series Mobile Pedestal Accessories

## Box Drawer Divider



Tip: TS2PBDD pedestal box drawer divider cannot be used with TS Series fixed under-worksurface pedestals.

Standard Includes	Required to Specify
<ul style="list-style-type: none"> <li>Box drawer divider: black plastic</li> </ul>	Style number

### Specification Information

Dimensions			Style Number	U.S. Price
D	W	H		
3/4"	12 3/4"	4 3/8"	TS2PBDD	\$5

## File Drawer Divider

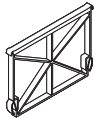

Tip: File drawer divider is required to file legal-sized files in pedestal file drawers.

Tip: TS2PFDD pedestal file drawer divider cannot be used with TS Series fixed under-worksurface pedestals.

Standard Includes	Required to Specify
<ul style="list-style-type: none"> <li>File drawer divider: black plastic</li> </ul>	Style number

### Specification Information

Dimensions			Style Number	U.S. Price
D	W	H		
3/4"	12 3/4"	9 3/16"	TS2PFDD	\$17

## Pencil Tray

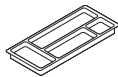

Standard Includes	Required to Specify
<ul style="list-style-type: none"> <li>Pencil tray: black plastic</li> </ul>	Style number

### Specification Information

Dimensions			Style Number	U.S. Price
D	W	H		
5 9/16"	12 7/8"	1"	TS2PPT	\$17



**For Canadian Pricing**  
Multiply U.S. Price by the Canadian price factor.  
▶ See page 1 for details.

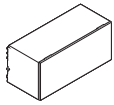

Tip: TS Series bins cannot be upmounted.

	Standard Includes	Required to Specify
▶ Need help? Product details, page 124	<ul style="list-style-type: none"> <li>Overhead bin with lift-up door: paint price group 1</li> <li>Recess beneath unit to accommodate shelf light</li> <li>Shelf backstop</li> <li>On-module attachment hooks with safety catch</li> <li>Lock, keyed random: 9201 Polished Chrome only</li> </ul>	<ol style="list-style-type: none"> <li>Style number</li> <li>Paint color number for overhead bin</li> <li>Options, if selected (see below)</li> </ol> <p>▶ See <i>Surface Materials</i>, page 360.</p>

	Options	U.S. Price	Required to Specify
<b>Surface Materials</b>	<b>Overhead bin</b> <ul style="list-style-type: none"> <li>Paint price group 1</li> <li>Paint price group 2</li> <li>Paint price group 3</li> </ul>	No cost +\$12 +\$28	Specify paint color number. Specify paint color number. Specify paint color number.
<b>Shelf Accessories</b>	<ul style="list-style-type: none"> <li>Four dividers: white plastic</li> </ul>	+\$76	Specify <i>with dividers</i> .
<b>Keying</b>	<ul style="list-style-type: none"> <li>Field-installed keying</li> </ul>		▶ Page 376
<b>Related Products</b>	<ul style="list-style-type: none"> <li>Shelf lights</li> </ul>		▶ Page 340

Specification Information					
Dimensions			Number of Doors	Style Number	U.S. Base Price
D	W	H			
<b>Bins with Flat Fronts</b>					
15 <sup>3</sup> / <sub>4</sub> "	24"	16 <sup>1</sup> / <sub>4</sub> "	1	<b>TSASUB24L</b>	\$ 692
15 <sup>3</sup> / <sub>4</sub> "	30"	16 <sup>1</sup> / <sub>4</sub> "	1	<b>TSASUB30L</b>	\$ 723
15 <sup>3</sup> / <sub>4</sub> "	36"	16 <sup>1</sup> / <sub>4</sub> "	1	<b>TSASUB36L</b>	\$ 753
15 <sup>3</sup> / <sub>4</sub> "	42"	16 <sup>1</sup> / <sub>4</sub> "	1	<b>TSASUB42L</b>	\$ 784
15 <sup>3</sup> / <sub>4</sub> "	48"	16 <sup>1</sup> / <sub>4</sub> "	1	<b>TSASUB48L</b>	\$ 824
15 <sup>3</sup> / <sub>4</sub> "	60"	16 <sup>1</sup> / <sub>4</sub> "	2	<b>TSASUB60L</b>	\$1274
15 <sup>3</sup> / <sub>4</sub> "	72"	16 <sup>1</sup> / <sub>4</sub> "	2	<b>TSASUB72L</b>	\$1402
:	:	:	:	:	:

 **For Canadian Pricing**  
 Multiply U.S. Price by the Canadian price factor.  
 ▶ See page 1 for details.

# Flexible Markerboard Surface

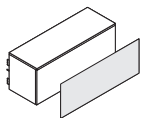

*Tip: To order the flexible markerboard surface parametrically, please see the Answer Solutions Specification Guide.*

Standard Includes	Required to Specify
-------------------	---------------------

- Flexible, magnetic markerboard surface to attach to door of overhead storage bin: white plastic

Style number

Specification Information			
• Dimensions		• Style	• U.S.
W	H	Number	Price

• Dimensions		• Style	• U.S.
W	H	Number	Price
30"	16¼"	<b>R30MBB</b>	\$177
36"	16¼"	<b>R36MBB</b>	\$187
42"	16¼"	<b>R42MBB</b>	\$193
48"	16¼"	<b>R48MBB</b>	\$205



**For Canadian Pricing**

Multiply U.S. Price by the Canadian price factor.

▶ See page 1 for details.

# TS Series Laminate Common Shelves

TS Series Laminate  
Common Shelves

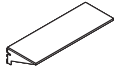

*Tip: For anticipated heavy loads on 42" and 48"W laminate common shelves, a field-installed reinforcing channel (TSATRC39) can be used.*

*Tip: Standard worksurfaces are 1/8" thick. However, the actual thickness between Low-Pressure Laminate (LPL) and High-Pressure Laminate (HPL) worksurfaces is slightly different. It is recommended that only worksurfaces of the same type are specified in a given application. In addition, there may be sheen or texture differences when using LPL and HPL in adjacent applications. Please use caution when mixing and matching different worksurface types.*

**For laminate price group 2 and 3 pricing, please refer to the electronic catalog or SmartTools.**

Standard Includes		Required to Specify
<ul style="list-style-type: none"> <li>▶ Need help? Product details, page 126</li> </ul>	<ul style="list-style-type: none"> <li>• 1 3/16"-thick shelf: Low-Pressure Laminate or High-Pressure Laminate price group 1</li> <li>• 3 mm radius profile edge: plastic</li> <li>• Support brackets: paint price group 1</li> </ul>	<ol style="list-style-type: none"> <li>1 Style number</li> <li>2 Low-Pressure Laminate or High-Pressure Laminate color number for shelf</li> <li>3 Plastic edge band color number for worksurface</li> <li>4 Paint color number for support bracket</li> <li>5 Options, if selected (see below)</li> </ol> <p>▶ See <i>Surface Materials</i>, page 360.</p>

Options	U.S. Price	Required to Specify
<b>Surface Materials</b> <ul style="list-style-type: none"> <li>• Paint price group 2</li> <li>• Paint price group 3</li> </ul>	+\$ 12 +\$ 28	Specify paint color number. Specify paint color number.
<b>High-Pressure Laminate worksurfaces</b>		
<ul style="list-style-type: none"> <li>• Laminate price group 2</li> <li>• Laminate price group 3</li> <li>• Open Line laminate</li> </ul>	See information at left See information at left +\$102 plus cost of laminate	Specify laminate color number. Specify laminate color number. ▶ See <i>Surface Materials Reference Manual</i> .

Specification Information						
Dimensions			Style Number	U.S. Base Price	Style Number	U.S. Base Price
D	W	H	LPL		HPL	
15"	24"	7 3/4"	<b>TSASLCL24</b>	\$187	<b>TSASHCL24</b>	\$234
15"	30"	7 3/4"	<b>TSASLCL30</b>	\$193	<b>TSASHCL30</b>	\$241
15"	36"	7 3/4"	<b>TSASLCL36</b>	\$205	<b>TSASHCL36</b>	\$255
15"	42"	7 3/4"	<b>TSASLCL42</b>	\$220	<b>TSASHCL42</b>	\$272
15"	48"	7 3/4"	<b>TSASLCL48</b>	\$240	<b>TSASHCL48</b>	\$299
:	:	:	:	:	:	:

 **For Canadian Pricing**  
Multiply U.S. Price by the Canadian price factor.  
▶ See page 1 for details.

# TS Series Under-Worksurface Lateral Files

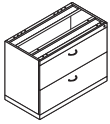

*Tip: TS Series under-worksurface lateral files are only intended for use under a panel-mounted worksurface and can not be used as freestanding.*

▶ See *Counterweight Requirements for Storage Products*, page 111.

*Tip: When filing with tabs, hanging file frames should be ordered, as folder's tabs may interfere with the opening and closing of each drawer.*

Standard Includes	Required to Specify
<ul style="list-style-type: none"> <li>▶ Need help? Product details, page 128</li> <li>• Lateral file: paint price group 1</li> <li>• Pulls: metal</li> <li>• Lock face ring with plastic plug to accommodate lock cylinder: 9201 Polished Chrome</li> <li>• Adjustable glides: black plastic</li> <li>• Hanging file frames for letter, legal, and A-4 filing: black</li> <li>• Attachment hardware</li> </ul>	<ul style="list-style-type: none"> <li>1 Style number</li> <li>2 Paint color number for lateral file</li> <li>3 Pull (see below under required selections)</li> <li>4 Options, if selected (see below)</li> <li>▶ See <i>Surface Materials</i>, page 360.</li> <li><i>Tip: Remember to specify lock cylinder and key.</i></li> <li>▶ <i>Lock Cylinders</i>, page 374</li> </ul>

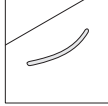
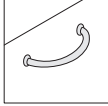
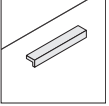
Required Selections
<p><b>Pulls</b></p> <div style="display: flex; justify-content: space-around; align-items: center;"> <div style="text-align: center;">  <p>Contemporary</p> </div> <div style="text-align: center;">  <p>Handle</p> </div> <div style="text-align: center;">  <p>Ledge</p> </div> </div>

Options	U.S. Price	Required to Specify
<p><b>Surface Materials</b></p> <ul style="list-style-type: none"> <li>• Paint price group 1</li> <li>• Paint price group 2</li> <li>• Paint price group 3</li> </ul>	<ul style="list-style-type: none"> <li>No cost</li> <li>+\$12</li> <li>+\$28</li> </ul>	<ul style="list-style-type: none"> <li>Specify paint color number.</li> <li>Specify paint color number.</li> <li>Specify paint color number.</li> </ul>
<p><b>Pulls</b></p> <ul style="list-style-type: none"> <li>• Contemporary pulls</li> <li>• Handle pulls</li> <li>• Ledge pulls: 7207 Black</li> <li>• Ledge pulls: 4799 Platinum</li> </ul>	<ul style="list-style-type: none"> <li>No cost</li> <li>No cost</li> <li>No cost</li> <li>+\$ 7</li> </ul>	<ul style="list-style-type: none"> <li>Specify <i>with contemporary pulls</i>.</li> <li>Specify <i>with handle pulls</i>.</li> <li>Specify <i>with 7207 Black ledge pulls</i>.</li> <li>Specify <i>with 4799 Platinum ledge pulls</i>.</li> </ul>
<p><b>Related Products</b></p> <ul style="list-style-type: none"> <li>• Lateral file side-to-side hanging file frames</li> <li>• Lateral file drawer dividers</li> <li>• Lateral file front-to-back rails</li> </ul>		<ul style="list-style-type: none"> <li>▶ Page 282</li> <li>▶ Page 282</li> <li>▶ Page 283</li> </ul>

Specification Information					
Dimensions			Counterweight Package	Style Number	U.S. Base Price
D	W	H			
18½"	30½"	27"	Not required	<b>TS2F230UL</b>	\$1101
18½"	36"	27"	Not required	<b>TS2F236UL</b>	\$1221



**For Canadian Pricing**  
 Multiply U.S. Price by the Canadian price factor.  
 ▶ See page 1 for details.

# TS Series Freestanding Lateral Files

TS Series Freestanding  
Lateral Files

Standard Includes		Required to Specify
<ul style="list-style-type: none"> <li>▶ Need help? Product details, page 130</li> </ul>	<ul style="list-style-type: none"> <li>Lateral file: paint price group 1</li> <li>Pulls: metal</li> <li>Lock face ring with plastic plug to accommodate lock cylinder: 9201 Polished Chrome</li> <li>Adjustable glides: black plastic</li> <li>Hanging file frames for letter, legal, and A-4 filing: black</li> <li>Attachment hardware</li> </ul>	<ol style="list-style-type: none"> <li>Style number</li> <li>Paint color number for lateral file</li> <li>Pull (see below under required selections)</li> <li>Options, if selected (see below)                             <ul style="list-style-type: none"> <li>▶ See <i>Surface Materials</i>, page 360.</li> <li><i>Tip: Remember to specify lock cylinder and key.</i></li> <li>▶ <i>Lock Cylinders</i>, page 374</li> </ul> </li> </ol>

## Required Selections

**Pulls**



Contemporary

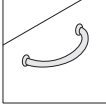

Handle

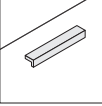

Ledge

Options	U.S. Price	Required to Specify
<b>Surface Materials</b> <ul style="list-style-type: none"> <li>Paint price group 1</li> <li>Paint price group 2</li> <li>Paint price group 3</li> </ul>	No cost +\$ 12 +\$ 28	Specify paint color number. Specify paint color number. Specify paint color number.
<b>Counterweights</b> <ul style="list-style-type: none"> <li>For use with 30"W file</li> <li>For use with 36"W file</li> </ul>	+\$344 +\$379	Specify with <i>TS2CW1 counterweight</i> . Specify with <i>TS2CW2 counterweight</i> .
<b>Pulls</b> <ul style="list-style-type: none"> <li>Contemporary pulls</li> <li>Handle</li> <li>Ledge pulls: 7207 Black</li> <li>Ledge pulls: 4799 Platinum</li> </ul>	No cost No cost No cost +\$ 7	Specify with <i>contemporary pulls</i> . Specify with <i>handle pulls</i> . Specify with <i>7207 Black ledge pulls</i> . Specify with <i>4799 Platinum ledge pulls</i> .
<b>Related Products</b> <ul style="list-style-type: none"> <li>Lateral file drawer dividers</li> <li>Lateral file side-to-side hanging file frames</li> <li>Lateral file front-to-back rails</li> <li>Counterweight packages</li> </ul>		▶ Page 282 ▶ Page 282 ▶ Page 283 ▶ Page 283

▶ See *Counterweight Requirements for Storage Products*, page 111.

## Specification Information

Dimensions			Counterweight Package	Style Number	U.S. Base Price
D	W	H			

### Open-Open Configurations

#### One 6"H Opening with Fixed Shelf and One 12"H Opening with Fixed Shelf

18½"	30"	21"	Not required	<b>TS2F130A</b>	\$ 924
18½"	36"	21"	Not required	<b>TS2F136A</b>	\$1021

### Drawer-Drawer Configurations

#### One 6"H Drawer and One 12"H Drawer

18½"	30"	21"	Package 1	<b>TS2F130B</b>	\$1143
18½"	36"	21"	Package 2	<b>TS2F136B</b>	\$1235

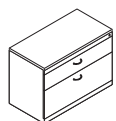
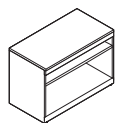

TS Series Storage

# TS Series Lateral File Accessories

## Lateral File Side-to-Side Hanging File Frames

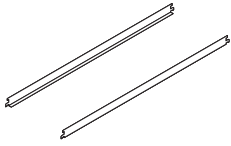

Standard Includes		Required to Specify
<ul style="list-style-type: none"> <li>▶ Need help? Product details, page 128</li> </ul>	<ul style="list-style-type: none"> <li>• Pair of hanging file frames to accommodate side-to-side filing: black paint</li> </ul>	Style number

### Specification Information

Dimensions			Style	U.S.
D	W	H	Number	Price

#### For Use with 30"W Freestanding Lateral File Drawer

1/8"	26 1/2"	1"	<b>TS2FHF30A</b>	\$44
------	---------	----	------------------	------

#### For Use with 30 1/2"W Under-Worksurface Lateral File Drawer

1/8"	27"	1"	<b>TS2FHF30</b>	\$45
------	-----	----	-----------------	------

#### For Use with 36"W Lateral File Drawer

1/8"	33"	1"	<b>TS2FHF36</b>	\$51
------	-----	----	-----------------	------

Tip: For use with 36"W freestanding or under-worksurface lateral files.

## Lateral File Drawer Dividers

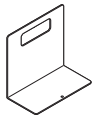

Standard Includes		Required to Specify
<ul style="list-style-type: none"> <li>▶ Need help? Product details, page 128</li> </ul>	<ul style="list-style-type: none"> <li>• Package of three under-worksurface lateral file drawer dividers: black paint</li> </ul>	Style number

### Specification Information

Dimensions			Style	U.S.
D	W	H	Number	Price

1/8"	15"	7"	<b>TS2FDV</b>	\$70
------	-----	----	---------------	------



**For Canadian Pricing**  
Multiply U.S. Price by the Canadian price factor.  
▶ See page 1 for details.

## Lateral File Front-to-Back Rails

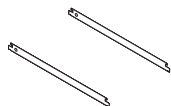

Standard Includes		Required to Specify
<ul style="list-style-type: none"> <li>▶ Need help? Product details, page 128</li> </ul>	<ul style="list-style-type: none"> <li>• Pair of rails to accommodate front-to-back filing: black paint</li> </ul>	Style number

Specification Information				
Dimensions			Style Number	U.S. Price
D	W	H		
1"	15"	1/2"	<b>TS2FFTBR</b>	\$17
:	:	:	:	:

## Counterweight Packages

For Use with TS Series Freestanding Lateral Files Only



Standard Includes		Required to Specify
<ul style="list-style-type: none"> <li>• Counterweight: black only</li> <li>• Attachment hardware</li> </ul>		Style number

Specification Information		
Package Name	Style Number	U.S. Price
Package 1	<b>TS2CW1</b>	\$344
Package 2	<b>TS2CW2</b>	\$379
:	:	:



**For Canadian Pricing**  
Multiply U.S. Price by the Canadian price factor.  
▶ See page 1 for details.

# TS Series Tower Too

Tip: Specify lock cylinders for each lock location.

Tip: For legal or side-to-side filing, use 15" Universal Storage rails, RXADRL15.

Tip: For box drawer dividers, use RDV1506 from the Universal Storage Collection. For file drawer dividers, use RDV1512 from the Universal Storage Collection.

Tip: For pencil trays, use RPXDPT from the Universal Storage collection.

Standard Includes		Required to Specify
▶ Need help? Product details, page 132	<ul style="list-style-type: none"> <li>• Tower Too: paint price group 1</li> <li>• Storage cabinet with two fixed shelves and two file drawers</li> <li>• Handle pulls, if selected: 0835 Black or 9211 Nickel</li> <li>• Contemporary pulls, if selected: paint</li> <li>• Lock face ring for drawers with plastic plug to accommodate lock cylinder: 9201 Polished Chrome</li> <li>• Wardrobe hook, if selected</li> <li>• Wardrobe rod with shelf, if selected</li> <li>• Adjustable leveling glides</li> </ul>	1 Style number 2 Paint color number for Tower Too 3 Color number for pulls 4 Options, if selected (see below) ▶ See <i>Surface Materials</i> , page 360. <i>Tip: Remember to specify lock cylinder and key.</i> ▶ <i>Lock Cylinders</i> , page 374

Options	U.S. Price	Required to Specify
<b>Surface Materials</b> <ul style="list-style-type: none"> <li>• Paint price group 1</li> <li>• Paint price group 2</li> <li>• Paint price group 3</li> </ul>	No cost +\$ 12 +\$ 28	Specify paint color number. Specify paint color number. Specify paint color number.
<b>Drawers</b> <ul style="list-style-type: none"> <li>• <b>Box drawers on 48"H, 54"H, and 66"H towers</b></li> <li>• Two box drawers in place of top file drawer</li> </ul>	+\$289	Specify with box/box/file.
<b>Pulls</b> <ul style="list-style-type: none"> <li>• Ledge pulls: 7207 Black</li> <li>• Ledge pulls: 4799 Platinum</li> </ul>	No cost +\$ 7	Specify with 7207 Black ledge pulls. Specify with 4799 Platinum ledge pulls.
<b>Lock</b> <ul style="list-style-type: none"> <li>• All locking (one lock for wardrobe, second lock for drawers, third lock for cabinet)</li> <li>• All locking for open side units (one lock for wardrobe, second lock for drawers)</li> </ul>	+\$246 +\$123	Specify with doors and drawers locking. Specify with door and drawers locking.

▶ See *Counterweight Requirements for Storage Products*, page 111.

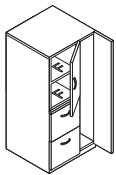

Specification Information						
Dimensions			Counterweight Package	Style Number		U.S. Base Price
D	W	H		Handle Pulls	Contemporary Pulls	

## Tower Too, Hinged Right

Wardrobe Hook						
24"	24"	54"	Not required	<b>TS2TWR54R</b>	<b>TS2TW54RC</b>	\$2464
24"	24"	66"	Not required	<b>TS2TWR66R</b>	<b>TS2TW66RC</b>	\$2539
Wardrobe Rod with Shelf						
24"	24"	54"	Not required	<b>TS2TWR54RS</b>	<b>TS2TW54RSC</b>	\$2599
24"	24"	66"	Not required	<b>TS2TWR66RS</b>	<b>TS2TW66RSC</b>	\$2668

## Tower Too, Hinged Left

Wardrobe Hook						
24"	24"	54"	Not required	<b>TS2TWR54L</b>	<b>TS2TW54LC</b>	\$2464
24"	24"	66"	Not required	<b>TS2TWR66L</b>	<b>TS2TW66LC</b>	\$2539
Wardrobe Rod with Shelf						
24"	24"	54"	Not required	<b>TS2TWR54LS</b>	<b>TS2TW54LSC</b>	\$2599
24"	24"	66"	Not required	<b>TS2TWR66LS</b>	<b>TS2TW66LSC</b>	\$2668

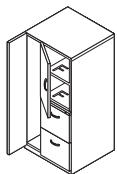

F=Fixed shelf

 **For Canadian Pricing**  
 Multiply U.S. Price by the Canadian price factor.  
 ▶ See page 1 for details.

▶ **Specification Information, continued on next page**

► **Specification Information, continued from previous page**

► See *Counterweight Requirements for Storage Products*, page 111.

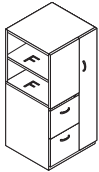

Specification Information						
Dimensions			Counterweight Package	Style Number		U.S. Base Price
D	W	H		Handle Pulls	Contemporary Pulls	

**Tower Too, Hinged Right with Open Side Shelving**

Wardrobe Hook						
24"	24"	48"	Not required	<b>TS2TWRS48R</b>	<b>TS2TWS48RC</b>	\$2862
24"	24"	54"	Not required	<b>TS2TWRS54R</b>	<b>TS2TWS54RC</b>	\$2903
24"	24"	66"	Not required	<b>TS2TWRS66R</b>	<b>TS2TWS66RC</b>	\$2978
Wardrobe Rod with Shelf						
24"	24"	48"	Not required	<b>TS2TWRS48RS</b>	<b>TS2TWS48RSC</b>	\$2987
24"	24"	54"	Not required	<b>TS2TWRS54RS</b>	<b>TS2TWS54RSC</b>	\$3031
24"	24"	66"	Not required	<b>TS2TWRS66RS</b>	<b>TS2TWS66RSC</b>	\$3107

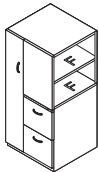

**Tower Too, Hinged Left with Open Side Shelving**

Wardrobe Hook						
24"	24"	48"	Not required	<b>TS2TWRS48L</b>	<b>TS2TWS48LC</b>	\$2862
24"	24"	54"	Not required	<b>TS2TWRS54L</b>	<b>TS2TWS54LC</b>	\$2903
24"	24"	66"	Not required	<b>TS2TWRS66L</b>	<b>TS2TWS66LC</b>	\$2978
Wardrobe Rod with Shelf						
24"	24"	48"	Not required	<b>TS2TWRS48LS</b>	<b>TS2TWS48LSC</b>	\$2987
24"	24"	54"	Not required	<b>TS2TWRS54LS</b>	<b>TS2TWS54LSC</b>	\$3031
24"	24"	66"	Not required	<b>TS2TWRS66LS</b>	<b>TS2TWS66LSC</b>	\$3107

F=Fixed shelf

**Dome**



Standard Includes	Required to Specify
<ul style="list-style-type: none"> <li>Need help? Product details, page 133</li> <li>Dome: paint price group 1</li> <li>Hardware package</li> </ul>	<ul style="list-style-type: none"> <li>1 Style number</li> <li>2 Paint color number for dome</li> <li>3 Options, if selected (see below)</li> </ul> <p>► See <i>Surface Materials</i>, page 360.</p>

Options	U.S. Price	Required to Specify
<b>Surface Materials</b>	<ul style="list-style-type: none"> <li>Paint price group 1: No cost</li> <li>Paint price group 2: +\$12</li> <li>Paint price group 3: +\$28</li> </ul>	<ul style="list-style-type: none"> <li>Specify paint color number.</li> <li>Specify paint color number.</li> <li>Specify paint color number.</li> </ul>

Specification Information				
Dimensions			Style Number	U.S. Base Price
D	W	H		
24"	24"	4½"	<b>TS2TDME</b>	\$868

 **For Canadian Pricing**  
 Multiply U.S. Price by the Canadian price factor.  
 ► See page 1 for details.

TS Series Storage



---

# Specifying Universal Steel Storage Products

<b>Universal Pedestals</b>	
Universal Fixed Pedestals	<b>288</b>
Universal Pedestal Fillers and Counterweights	<b>290</b>
Universal Fixed to Freestanding Pedestal Conversion Kits	<b>291</b>
Universal Mobile Pedestals	<b>292</b>
Basic Cushions Enhanced	<b>295</b>
<b>Universal Bins and Shelves</b>	
Universal Sliding Door Bins	<b>296</b>
Universal Over the Case Bins	<b>298</b>
Universal In the Case Bins	<b>300</b>
Universal Shelves	<b>303</b>
Accessories for Universal Bins and Shelves	<b>304</b>
<b>Slim Shelves</b>	<b>308</b>
<b>Universal One-High, 1.5-High, and Two Drawer Lateral Files</b>	<b>310</b>
<b>Low Storage-to-Beam Tether Bracket</b>	<b>315</b>
<b>Basic Cushions Enhanced</b>	<b>316</b>
<b>Cushion Tops</b>	<b>317</b>
<b>Universal Towers</b>	
Universal Open Side Towers	<b>318</b>
Universal Dual Door Towers	<b>322</b>
<b>Universal Lateral Files</b>	<b>328</b>
<b>Steel Storage Accessories</b>	<b>332</b>

# Universal Fixed Pedestals

With Flush Steel, Proud Steel, Proud Laminate, or Proud Wood Fronts

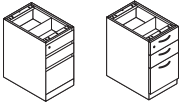

Standard Includes		Required to Specify
<ul style="list-style-type: none"> <li>▶ Need help? Product details, page 140</li> </ul>	<ul style="list-style-type: none"> <li>• Pedestal: paint price group 1</li> <li>• Removable drawer fronts: paint to match pedestal, laminate price group 1 if proud laminate front selected, or wood group 1 veneer if proud wood front selected</li> <li>• Integral pulls on units with flush steel fronts</li> <li>• Pulls: metal                             <ul style="list-style-type: none"> <li>– One pencil tray and two box drawer dividers per box/file</li> </ul> </li> <li>• Full drawer interiors: black only</li> <li>• Lock, keyed random: 9201 Polished Chrome</li> <li>• Mounting hardware</li> <li>• Four adjustable leveling glides</li> </ul>	<ol style="list-style-type: none"> <li>1 Style number with appropriate front style suffix in the space provided                             <ul style="list-style-type: none"> <li><b>F</b> Flush steel front</li> <li><b>P</b> Proud steel front</li> <li><b>L</b> Proud laminate front</li> <li><b>W</b> Proud wood front</li> </ul> </li> <li>2 Paint color number for pedestal</li> <li>3 Laminate color number for drawer fronts, if proud laminate front selected</li> <li>4 Wood color number for drawer fronts, if proud wood front selected</li> <li>5 Pull (see below under Required Selections)</li> <li>6 Metal color number for pulls, if proud steel or proud wood front selected</li> <li>7 Options, if selected (see below)</li> </ol> <p>▶ See <i>Surface Materials</i>, page 360.</p>

## Required Selections

### Pulls

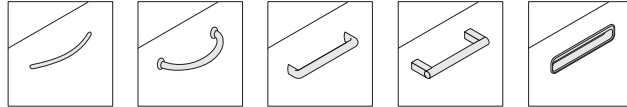

Contemporary Handle Jazz Bar c:scape

	Options	U.S. Price	Required to Specify
<b>Surface Materials</b>	<ul style="list-style-type: none"> <li>• Paint price group 1</li> <li>• Paint price group 2</li> <li>• Paint price group 3</li> </ul>	<ul style="list-style-type: none"> <li>No cost</li> <li>+\$ 65</li> <li>+\$111</li> </ul>	<ul style="list-style-type: none"> <li>Specify paint color number.</li> <li>Specify paint color number.</li> <li>Specify paint color number.</li> </ul>
	<ul style="list-style-type: none"> <li>• Laminate price group 1 on proud laminate drawer fronts</li> <li>• Laminate price group 2 on proud laminate drawer fronts</li> <li>• Laminate price group 3 on proud laminate drawer fronts</li> <li>• Open Line laminate on proud laminate drawer fronts</li> </ul>	<ul style="list-style-type: none"> <li>Prices at right</li> <li>See information at left</li> <li>See information at left</li> <li>+\$102 plus cost of laminate</li> </ul>	<ul style="list-style-type: none"> <li>Specify laminate color number.</li> <li>Specify laminate color number.</li> <li>Specify laminate color number.</li> <li>▶ See <i>Surface Materials Reference Manual</i>.</li> </ul>
	<ul style="list-style-type: none"> <li>• Wood group 2 on proud wood drawer fronts</li> <li>• Wood group 3 on proud wood drawer fronts</li> <li>• Customiz stain on proud wood drawer fronts</li> </ul>	<ul style="list-style-type: none"> <li>See information at left</li> <li>See information at left</li> <li>No cost</li> </ul>	<ul style="list-style-type: none"> <li>Specify wood color number.</li> <li>Specify wood color number.</li> <li>Specify <i>with Customiz stain</i>.</li> <li>▶ See <i>Surface Materials Reference Manual</i>.</li> </ul>
	<b>Pulls</b>	<b>Flush steel fronts</b>	
	<ul style="list-style-type: none"> <li>• Full-width wood veneer pull</li> <li>• Customiz stain on wood veneer pull</li> </ul>	<ul style="list-style-type: none"> <li>+\$390</li> <li>No cost</li> </ul>	<ul style="list-style-type: none"> <li>Specify <i>with wood pull</i> and indicate wood color number.</li> <li>Specify <i>with Customiz stain</i>.</li> <li>▶ See <i>Surface Materials Reference Manual</i>.</li> </ul>
	<b>Proud steel, laminate, or wood fronts</b>		
	<ul style="list-style-type: none"> <li>• Contemporary</li> <li>• Handle</li> <li>• Jazz</li> <li>• Bar</li> </ul>	<ul style="list-style-type: none"> <li>No cost</li> <li>No cost</li> <li>+\$ 28 per pull</li> <li>+\$ 43 per pull</li> </ul>	<ul style="list-style-type: none"> <li>Specify <i>with contemporary pull</i>.</li> <li>Specify <i>with handle pull</i>.</li> <li>Specify <i>with jazz pull</i>.</li> <li>Specify <i>with bar pull</i>.</li> </ul>
	<b>Proud steel fronts only</b>		
	<ul style="list-style-type: none"> <li>• c:scape</li> </ul>	<ul style="list-style-type: none"> <li>+\$ 48 per pull</li> </ul>	<ul style="list-style-type: none"> <li>Specify <i>with c:scape pull</i>.</li> </ul>

**For wood and laminate group 2 and 3 pricing, please refer to the electronic catalog or SmartTools.**

 **For Canadian Pricing**  
Multiply U.S. Price by the Canadian price factor.  
▶ See page 1 for details.

▶ Options, continued on next page

► Options, continued from previous page

Options	U.S. Price	Required to Specify
<b>Drawer Accessories</b> <b>Rails</b> • Two side-to-side hanging rails per file drawer	No cost	Specify with rails.
<b>Basic Drawer Interiors</b> <b>18"D, 24"D, and 30"D box/box/file pedestals</b> • No rails, pencil trays, or box drawer dividers	-\$ 80	Specify with basic drawers.
<b>Lock and Keying</b> <b>Lock</b> • Ember Chrome • No lock	No cost -\$101	Specify with 9250 Ember Chrome lock. Specify with no lock.
<b>Individual locking drawers</b> • File/file pedestals only	+\$191	Specify with individual lock.
<b>Keying</b> • Factory- and field-installed keying		► Page 375
<b>Related Products</b> • Universal fixed to freestanding pedestal conversion kits • Steel storage accessories		► Page 291 ► Page 332

Tip: Counterweight packages are required to ensure product stability and are ordered as an option or separately. Product specification pages indicate the correct counterweight package for each style number and any exceptions where counterweights are not required.  
► See Counterweight Requirements for Storage Products, page 111.

Tip: Your specification is not complete until you add a suffix to the style number to define the front style (for example, RPF1827A\_\_ becomes RPF1827AP for proud steel front).

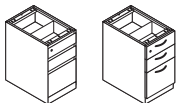

Tip: Use 27"H pedestals to align with Universal Storage with 3" base. 27"H pedestals support worksurfaces at 28½"H.

Tip: Only 22⅝"D, 23½"D, 28⅝"D, and 29½"D pedestals can accommodate legal-size filing.

Specification Information

Dimensions		W	H	Counterweight Package	Style Number	U.S. Base Prices			
D	Front					Flush Steel Front	Proud Steel/Lam/Wood Front	Flush Steel Front	Proud Steel Front
						Suffix F	Suffix P	Suffix L	Suffix W

27"H Fixed Pedestals with 3" Base

Two Box Drawers and One File Drawer

17½"	18⅜"	15"	27"	RPCW	<b>RPF1827A__</b>	\$ 908	\$1007	\$1277	\$1385
22⅝"	23½"	15"	27"	RPCW	<b>RPF2427A__</b>	\$ 991	\$1090	\$1360	\$1468
28⅝"	29½"	15"	27"	RPCW	<b>RPF3027A__</b>	\$1191	\$1290	\$1560	\$1668

Two File Drawers

17½"	18⅜"	15"	27"	RPCW	<b>RPF1827B__</b>	\$ 879	\$ 978	\$1248	\$1356
22⅝"	23½"	15"	27"	RPCW	<b>RPF2427B__</b>	\$ 962	\$1061	\$1331	\$1439
28⅝"	29½"	15"	27"	RPCW	<b>RPF3027B__</b>	\$1162	\$1261	\$1531	\$1639



**For Canadian Pricing**  
Multiply U.S. Price by the Canadian price factor.  
► See page 1 for details.

# Universal Pedestal Fillers and Counterweights

## Universal Pedestal Fillers for 27"H Fixed Pedestals with Flush and Proud Fronts



Standard Includes		Required to Specify
▶ Need help? Product details, page 141	<ul style="list-style-type: none"> <li>• Filler: all paint price groups</li> <li>• Installation hardware</li> </ul>	1 Style number 2 Paint color number for filler ▶ See <i>Surface Materials</i> , page 360.

Specification Information					
Dimensions		On- or Off-Module	Application	Style Number	U.S. Price
D	H				
Flush Steel Front	Proud Steel/Wood Front				

### Pedestal Fillers for 27"H Fixed Pedestals with Flush Steel Fronts

13/8"	N.A.	27"	On-Module	Answer and Kick Panels	<b>RPXFTAKFP</b>	\$107
-------	------	-----	-----------	------------------------	------------------	-------

### Pedestal Fillers for 27"H Fixed Pedestals with Proud Fronts

N.A.	1/2"	27"	On-Module	Answer and Kick Panels	<b>RPXFTAKPP</b>	\$107
------	------	-----	-----------	------------------------	------------------	-------

## Universal Pedestal Counterweight

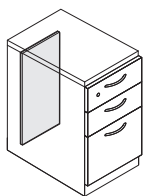

Tip: Counterweights fit 27"H fixed pedestals only.

Standard Includes		Required to Specify
▶ Need help? Product details, page 141	<ul style="list-style-type: none"> <li>• Pedestal counterweight: black</li> </ul>	Style number

Specification Information	
Style Number	U.S. Price
<b>RPCW</b>	\$221



### For Canadian Pricing

Multiply U.S. Price by the Canadian price factor.

▶ See page 1 for details.

# Universal Fixed to Freestanding Pedestal Conversion Kits

Universal Fixed to  
Freestanding Pedestal  
Conversion Kits

Universal Storage

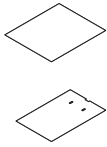

*Tip: Flush and proud front pedestals require different conversion kits. Be sure to order the correct style number for your application.*

*Tip: When converting a file/file pedestal with individual drawer locks, an interlocking bar is required to provide stability to unit. Order 1043922SR through Service Parts.*

Standard Includes		Required to Specify
▶ Need help? Product details, page 141	<ul style="list-style-type: none"> <li>• 1/8"H steel top: all paint price groups</li> <li>• Counterweight package</li> <li>• Installation hardware</li> </ul>	1 Style number 2 Paint color number for top ▶ See <i>Surface Materials</i> , page 360.

Specification Information		
Dimensions	Style	U.S.
D H	Number	Price

## For 27"H Proud Steel or Proud Wood Front Pedestals

18 3/8"	27"	<b>RPXCK2718P</b>	\$307
23 1/2"	27"	<b>RPXCK2724P</b>	\$338
29 1/2"	27"	<b>RPXCK2730P</b>	\$374

## For 27"H Flush Steel Front Pedestals

17 1/2"	27"	<b>RPXCK2718F</b>	\$307
22 5/8"	27"	<b>RPXCK2724F</b>	\$338
28 5/8"	27"	<b>RPXCK2730F</b>	\$374



### For Canadian Pricing

Multiply U.S. Price by the Canadian price factor.

▶ See page 1 for details.

# Universal Mobile Pedestals

With Flush Steel, Proud Steel, Proud Laminate, or Proud Wood Fronts

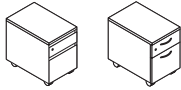

Tip: 1/8"H steel top is non-structural.

Tip: Counterweight packages for mobile pedestals are required to ensure product stability and are included.

▶ See Counterweight Requirements for Storage Products, page 111.

Standard Includes		Required to Specify
▶ Need help? Product details, page 140	<ul style="list-style-type: none"> <li>• Pedestal: paint price group 1</li> <li>• 1/8"H steel top: paint to match pedestal</li> <li>• Removable drawer fronts: paint to match pedestal, laminate price group 1 if proud laminate selected, or wood group 1 veneer if proud wood front selected</li> <li>• Integral pulls on units with flush steel fronts</li> <li>• Pulls: metal</li> <li>• Full drawer interiors: black only                             <ul style="list-style-type: none"> <li>– One pencil tray per box/file or box/box/file and box drawer dividers</li> </ul> </li> <li>• Lock, keyed random: 9201 Polished Chrome</li> <li>• Four hard-composition, non-locking casters: black only</li> <li>• Safety interlock mechanism</li> <li>• Counterweight package</li> </ul>	<ol style="list-style-type: none"> <li>1 Style number with appropriate front style suffix in the space provided                             <ul style="list-style-type: none"> <li><b>F</b> Flush steel front</li> <li><b>P</b> Proud steel front</li> <li><b>L</b> Proud laminate front</li> <li><b>W</b> Proud wood front</li> </ul> </li> <li>2 Paint color number for pedestal</li> <li>3 Laminate color number for drawer fronts, if proud laminate front selected</li> <li>4 Wood color number for drawer fronts, if proud wood front selected</li> <li>5 Pull (see below under Required Selections)</li> <li>6 Metal color number for pulls, if proud steel, proud laminate, or proud wood front selected</li> <li>7 Options, if selected (see below)</li> </ol> <p>▶ See Surface Materials, page 360.</p>

## Required Selections

### Pulls

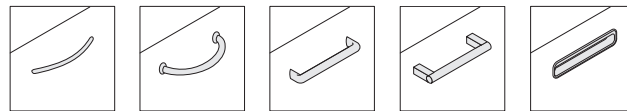

Contemporary Handle Jazz Bar c:scape

Options	U.S. Price	Required to Specify
<b>Surface Materials</b> <ul style="list-style-type: none"> <li>• Paint price group 1</li> <li>• Paint price group 2</li> <li>• Paint price group 3</li> </ul>	No cost +\$ 65 +\$111	Specify paint color number. Specify paint color number. Specify paint color number.
<ul style="list-style-type: none"> <li>• Laminate price group 1 on proud laminate drawer fronts</li> <li>• Laminate price group 2 on proud laminate drawer fronts</li> <li>• Laminate price group 3 on proud laminate drawer fronts</li> <li>• Open Line laminate on proud laminate drawer fronts</li> </ul>	Prices at right See information at left See information at left +\$102 plus cost of laminate	Specify laminate color number. Specify laminate color number. Specify laminate color number. ▶ See Surface Materials Reference Manual.
<ul style="list-style-type: none"> <li>• Wood group 2 on proud wood drawer fronts</li> <li>• Wood group 3 on proud wood drawer fronts</li> <li>• Customiz stain on proud wood drawer fronts</li> </ul>	See information at left See information at left No cost	Specify wood color number. Specify wood color number. Specify with Customiz stain. ▶ See Surface Materials Reference Manual.
<b>Tops</b> <ul style="list-style-type: none"> <li>• 1"H square edge steel top</li> </ul>	+\$105	Specify with steel square top.
<b>Laminate top</b> <ul style="list-style-type: none"> <li>• 1 3/16"H square edge laminate price group 1 top</li> <li>• 1 3/16"H square edge laminate price group 2 top</li> <li>• 1 3/16"H square edge laminate price group 3 top</li> <li>• Open Line laminate on laminate top</li> </ul>	+\$440 See information at left See information at left +\$102 plus cost of laminate	Specify with laminate top and indicate laminate color number for top and plastic color number for edges. Specify with laminate top and indicate laminate color number for top and plastic color number for edges. Specify with laminate top and indicate laminate color number for top and plastic color number for edges. ▶ See Surface Materials Reference Manual.

▶ Options, continued on next page

For wood and laminate group 2 and 3 pricing, please refer to the electronic catalog or SmartTools.

Tip: Optional tops will increase the overall pedestal height.



**For Canadian Pricing**  
 Multiply U.S. Price by the Canadian price factor.  
 ▶ See page 1 for details.

► Options, continued from previous page

	Options	U.S. Price	Required to Specify
<b>Tops, continued</b>	<b>Wood veneer top</b>		
	• 1 <sup>3</sup> / <sub>16</sub> "H wood group 1 veneer top	+\$ 595	Specify with wood veneer top and indicate wood color number.
	• 1 <sup>3</sup> / <sub>16</sub> "H wood group 2 veneer top	See information at left	Specify with wood veneer top and indicate wood color number.
	• 1 <sup>3</sup> / <sub>16</sub> "H wood group 3 veneer top	See information at left	Specify with wood veneer top and indicate wood color number.
	• Customiz stain on wood veneer top	No cost	Specify with Customiz stain. ► See Surface Materials Reference Manual.
	<b>Cushion top for factory installation on RPM2421C__ only</b>		
	• Cushion top without handle	+\$ 544	Specify with cushion top and indicate fabric color number.
	• Cushion top with black handle	+\$ 685	Specify with cushion top and handle and indicate fabric color number.
	<b>Upholstery on pedestal cushion top</b>		
	• Fabric price group 1	No cost	Specify fabric color number.
	• Fabric price group 2	+\$ 12	Specify fabric color number.
	• Fabric price group 3	+\$ 59	Specify fabric color number.
	• Fabric price group 4	+\$ 73	Specify fabric color number.
	• Fabric price group 5	+\$ 92	Specify fabric color number.
	• Fabric price group 6	+\$ 129	Specify fabric color number.
	• Fabric price group 7	+\$ 154	Specify fabric color number.
	• Fabric price group 8	+\$ 223	Specify fabric color number.
	• Fabric price group 9	+\$ 286	Specify fabric color number.
	• Fabric price group 10	+\$ 348	Specify fabric color number.
	• Leather price group	+\$ 894	Specify leather color number.
	• Elmosoft leather upholstery	+\$1030	Specify Elmosoft leather color number. ► See Surface Materials Reference Manual
	• Customer's Own Material (COM) or Customer's Own Leather (COL).	+\$ 23	► See Surface Materials Reference Manual to specify.
<b>Pulls</b>	<b>Flush steel fronts</b>		
	• Full-width wood veneer pull	+\$ 390	Specify with wood pull and indicate wood color number.
	• Customiz stain on wood veneer pull	No cost	Specify with Customiz stain. ► See Surface Materials Reference Manual.
	<b>Proud steel, laminate, or wood fronts</b>		
	• Contemporary	No cost	Specify with contemporary pull.
	• Handle	No cost	Specify with handle pull.
	• Jazz	+\$ 28 per pull	Specify with jazz pull.
	• Bar	+\$ 43 per pull	Specify with bar pull.
	<b>Proud steel fronts only</b>		
	• c:scape	+\$ 48 per pull	Specify with c:scape pull.
<b>Drawer Accessories</b>	<b>Rails</b>		
	• Two side-to-side hanging file rails per file drawer	No cost	Specify with rails.
<b>Basic Drawer Interiors</b>	<b>Box/file and box/box/file pedestals</b>		
	• No rails, pencil trays, or box drawer dividers	-\$ 80	Specify with basic drawers.

► Options, continued on next page

Tip: If wood veneer top option is selected, finishes must be selected for both the wood veneer top and the wood veneer fronts.

**For wood and laminate group 2 and 3 pricing,** please refer to the electronic catalog or SmartTools.

Tip: For both cushion top and basic cushion enhanced: fabric patterns with a linear design will always be applied from the front to back of the unit (depth of the unit).

Tip: For both cushion top and basic cushion enhanced: pattern matching will not be done on COM.



**For Canadian Pricing**  
Multiply U.S. Price by the Canadian price factor.  
► See page 1 for details.

Universal Mobile Pedestals with Flush Steel, Proud Steel, Proud Laminate, or Proud Wood Fronts, continued

► Options, continued from previous page

Options	U.S. Price	Required to Specify
<b>Lock and Keying</b>		
<b>Lock</b>		
• Ember Chrome	No cost	Specify with 9250 Ember Chrome lock.
<b>Individual locking drawers</b>		
• File/file pedestals only	+\$194	Specify with individual lock.
<b>Keying</b>		
• Factory- and field-installed keying		► Page 375
<b>Related Products</b>		
• Steel storage accessories		► Page 332
• Basic cushions enhanced		► Page 295

Tip: Your specification is not complete until you add a suffix to the style number to define the front style (for example, RPM1821C\_\_ becomes RPM1821CP for proud steel front).

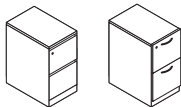
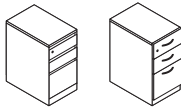
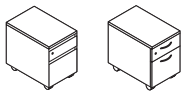

Specification Information									
Dimensions D	W	H	Counter-weight Package	Style Number	U.S. Base Prices				
					Flush Steel Front Suffix F	Proud Steel Front Suffix P	Proud Lam Front Suffix L	Proud Wood Front Suffix W	

**Box/File**

17½"	18¾"	15"	21"	Included	<b>RPM1821C__</b>	\$1246	\$1345	\$1615	\$1723
22⅝"	23½"	15"	21"	Included	<b>RPM2421C__</b>	\$1358	\$1457	\$1727	\$1835

**Box/Box/File**

17½"	18¾"	15"	27"	Included	<b>RPM1827A__</b>	\$1424	\$1477	\$1753	\$1861
22⅝"	23½"	15"	27"	Included	<b>RPM2427A__</b>	\$1518	\$1566	\$1842	\$1950

**File/File**

17½"	18¾"	15"	27"	Included	<b>RPM1827B__</b>	\$1353	\$1448	\$1724	\$1832
22⅝"	23½"	15"	27"	Included	<b>RPM2427B__</b>	\$1492	\$1537	\$1813	\$1921

Specification Information				
Actual Dimensions D W H	Style Number	U.S. Base Price		

**Pedestal Cushion Top for Field Installation on RPM2421C\_\_ only**

**Cushion Top without Handle**

22⅝"	15"	2¼"	<b>RPXTC24F</b>	\$483	(For use with RPM2421CF only)
23½"	15"	2¼"	<b>RPXTC24P</b>	\$483	(For use with RPM2421CP, RPM2421CL, and RPM2421CW only)

**Cushion Top with Black Handle**

22⅝"	15"	2¼"	<b>RPXTCH24F</b>	\$649	(For use with RPM2421CF only)
23½"	15"	2¼"	<b>RPXTCH24P</b>	\$649	(For use with RPM2421CP, RPM2421CL, and RPM2421CW only)



Tip: If used with a Universal mobile pedestal manufactured before 12/20/2011, you will need to order service part 1072962001SR for attachment hardware.

# Basic Cushions Enhanced

For Universal Mobile Pedestals

Basic Cushions Enhanced

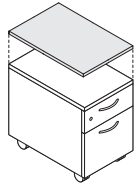

*Tip: Basic cushion enhanced is field-installed and supplies to attach are included.*

*Tip: Basic cushion enhanced is available on Universal mobile pedestals RPM1821CF, RPM1821CP, RPM1821CL, RPM1821CW, RPM2421CF, RPM2421CP, RPM2421CL, and RPM2421CW with a top only.*

*Tip: Basic cushion enhanced is constructed with a thin solid base.*

*Tip: For both cushion top and basic cushion enhanced: Fabric patterns with a linear design will always be applied from the front to back of the unit (depth of the unit).*

*Tip: For both cushion top and basic cushion enhanced: Pattern matching will not be done on COM.*

Standard Includes		Required to Specify
<ul style="list-style-type: none"> <li>▶ Need help? Product details, page 140</li> </ul>	<ul style="list-style-type: none"> <li>• Enhanced cushion top: fabric price group 1</li> <li>• Attachment supplies: hook and loop fastener</li> </ul>	<ul style="list-style-type: none"> <li>1 Style number</li> <li>2 Fabric color number for cushion top</li> <li>3 Options, if selected (see below)</li> <li>▶ See <i>Surface Materials</i>, page 360.</li> </ul>

Options	U.S. Price	Required to Specify
<b>Surface Materials</b>	<b>Upholstery</b>	
	<ul style="list-style-type: none"> <li>• Fabric price group 1 No cost</li> <li>• Fabric price group 2 +\$ 12</li> <li>• Fabric price group 3 +\$ 59</li> <li>• Fabric price group 4 +\$ 73</li> <li>• Fabric price group 5 +\$ 92</li> <li>• Fabric price group 6 +\$129</li> <li>• Fabric price group 7 +\$154</li> <li>• Fabric price group 8 +\$223</li> <li>• Fabric price group 9 +\$286</li> <li>• Fabric price group 10 +\$348</li> <li>• Customer's Own Material (COM) +\$ 23</li> </ul>	<ul style="list-style-type: none"> <li>Specify fabric color number.</li> <li>Specify fabric color number.</li> <li>Specify fabric color number.</li> <li>Specify fabric color number.</li> <li>Specify fabric color number.</li> <li>Specify fabric color number.</li> <li>Specify fabric color number.</li> <li>Specify fabric color number.</li> <li>Specify fabric color number.</li> <li>Specify fabric color number.</li> <li>▶ See <i>Surface Materials Reference Manual</i>.</li> </ul>

Related Products		
<ul style="list-style-type: none"> <li>• Universal mobile pedestals</li> </ul>		▶ Page 292

Specification Information				
Dimensions			Style Number	U.S. Base Price
D	W	H		
17½"	15"	1"	<b>RCHE1715</b>	\$275
22⅝"	15"	1"	<b>RCHE2315</b>	\$289

Universal Storage

 **For Canadian Pricing**  
 Multiply U.S. Price by the Canadian price factor.  
 ▶ See page 1 for details.

# Universal Sliding Door Bins with Steel, Laminate, or Wood Fronts

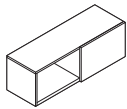

	Standard Includes	Required to Specify
<ul style="list-style-type: none"> <li>▶ Need help? Product details, page 144</li> </ul>	<ul style="list-style-type: none"> <li>• Overhead bin: paint price group 1</li> <li>• Sliding door: paint price group 1, laminate price group 1, or wood group 1</li> <li>• Recess beneath unit to accommodate shelf light</li> <li>• Shelf backstop</li> <li>• On-module attachment brackets with safety catch: black paint only</li> <li>• Vertical off-module attachment brackets, if selected: black paint only</li> <li>• Lock, keyed random: 9201 Polished Chrome</li> </ul>	<ol style="list-style-type: none"> <li>1 Style number</li> <li>2 Paint color number for overhead bin</li> <li>3 Paint, laminate, or wood color number for door</li> <li>4 Options, if selected (see below)</li> </ol> <ul style="list-style-type: none"> <li>▶ See <i>Surface Materials</i>, page 360.</li> </ul>

**For wood and laminate group 2 and 3 pricing, please refer to the electronic catalog or SmartTools.**

	Options	U.S. Price	Required to Specify
<b>Surface Materials</b>	<b>Overhead bin with one steel door</b>		
	<ul style="list-style-type: none"> <li>• Paint price group 1</li> <li>• Paint price group 2</li> <li>• Paint price group 3</li> </ul>	<ul style="list-style-type: none"> <li>No cost</li> <li>+\$ 65</li> <li>+\$111</li> </ul>	<ul style="list-style-type: none"> <li>Specify paint color number.</li> <li>Specify paint color number.</li> <li>Specify paint color number.</li> </ul>
	<b>Overhead bin with one laminate or wood door</b>		
	<ul style="list-style-type: none"> <li>• Paint price group 1</li> <li>• Paint price group 2</li> <li>• Paint price group 3</li> <li>• Laminate price group 1 on laminate door</li> <li>• Laminate price group 2 on laminate door</li> <li>• Laminate price group 3 on laminate door</li> <li>• Open Line laminate on laminate door</li> <li>• Wood group 2 on wood door</li> <li>• Wood group 3 on wood door</li> <li>• Customiz stain on wood door</li> </ul>	<ul style="list-style-type: none"> <li>No cost</li> <li>+\$ 65</li> <li>+\$101</li> <li>Prices at right</li> <li>See information at left</li> <li>See information at left</li> <li>+\$102 plus cost of laminate</li> <li>See information at left</li> <li>See information at left</li> <li>No cost</li> </ul>	<ul style="list-style-type: none"> <li>Specify paint color number.</li> <li>Specify paint color number.</li> <li>Specify paint color number.</li> <li>Specify laminate color number.</li> <li>Specify laminate color number.</li> <li>Specify laminate color number.</li> <li>▶ See <i>Surface Materials Reference Manual</i>.</li> <li>Specify wood color number.</li> <li>Specify wood color number.</li> <li>Specify with <i>Customiz stain</i>.</li> <li>▶ See <i>Surface Materials Reference Manual</i>.</li> </ul>
<b>Brackets</b>	<b>Off-module attachment brackets</b>		
	<ul style="list-style-type: none"> <li>• One vertical off-module bracket</li> <li>• Two vertical off-module brackets</li> </ul>	<ul style="list-style-type: none"> <li>+\$ 98</li> <li>+\$196</li> </ul>	<ul style="list-style-type: none"> <li>Specify with one vertical off-module bracket.</li> <li>Specify with two vertical off-module brackets.</li> </ul>
	<b>Upmount brackets</b>		
	<ul style="list-style-type: none"> <li>• Upmount kit</li> </ul>	<ul style="list-style-type: none"> <li>+\$288</li> </ul>	<ul style="list-style-type: none"> <li>Specify with upmount kit.</li> </ul>
	<b>No brackets</b>		
	<ul style="list-style-type: none"> <li>• Omit brackets</li> </ul>	<ul style="list-style-type: none"> <li>-\$ 31</li> </ul>	<ul style="list-style-type: none"> <li>Specify omit brackets.</li> </ul>
<b>Shelf Accessories</b>	<ul style="list-style-type: none"> <li>• Four dividers: white plastic</li> </ul>	<ul style="list-style-type: none"> <li>+\$ 76</li> </ul>	<ul style="list-style-type: none"> <li>Specify with dividers.</li> </ul>
<b>Lock and Keying</b>	<b>Lock</b>		
	<ul style="list-style-type: none"> <li>• No lock</li> <li>• Ember Chrome</li> </ul>	<ul style="list-style-type: none"> <li>-\$104</li> <li>No cost</li> </ul>	<ul style="list-style-type: none"> <li>Specify with no lock.</li> <li>Specify with 9250 Ember Chrome lock.</li> </ul>
	<b>Keying</b>		
	<ul style="list-style-type: none"> <li>• Factory- and field-installed keying</li> </ul>		<ul style="list-style-type: none"> <li>▶ Page 375</li> </ul>
<b>Related Products</b>	<ul style="list-style-type: none"> <li>• Accessories</li> <li>• Shelf lights</li> </ul>		<ul style="list-style-type: none"> <li>▶ Page 304</li> <li>▶ Page 352</li> </ul>



**For Canadian Pricing**  
Multiply U.S. Price by the Canadian price factor.  
▶ See page 1 for details.

**Specification Information**

Dimensions			Style Number	U.S. Base Price	Style Number	U.S. Base Price	Style Number	U.S. Base Price
D	W	H						
			<b>Steel Fronts</b>		<b>Laminate Fronts</b>		<b>Wood Fronts</b>	
15¾"	36"	16¼"	<b>RSB36TAK</b>	\$1050	<b>RSB36LTAK</b>	\$1602	<b>RSB36WTAK</b>	\$1646
15¾"	42"	16¼"	<b>RSB42TAK</b>	\$1088	<b>RSB42LTAK</b>	\$1640	<b>RSB42WTAK</b>	\$1684
15¾"	48"	16¼"	<b>RSB48TAK</b>	\$1119	<b>RSB48LTAK</b>	\$1671	<b>RSB48WTAK</b>	\$1715
15¾"	60"	16¼"	<b>RSB60TAK</b>	\$1693	<b>RSB60LTAK</b>	\$2692	<b>RSB60WTAK</b>	\$2736
15¾"	66"	16¼"	<b>RSB66TAK</b>	\$1784	<b>RSB66LTAK</b>	\$2783	<b>RSB66WTAK</b>	\$2827
15¾"	72"	16¼"	<b>RSB72TAK</b>	\$1852	<b>RSB72LTAK</b>	\$2851	<b>RSB72WTAK</b>	\$2895

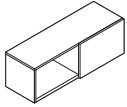

Tip: Overhead storage bins with a "TAK" suffix can be used with Privacy Wall as well.

► See Architectural Solutions Specification Guide for attachment information.



**For Canadian Pricing**

Multiply U.S. Price by the Canadian price factor.

► See page 1 for details.

# Universal Over the Case Bins with Flat Fronts

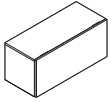

	Standard Includes	Required to Specify
▶ Need help? Product details, page 148	<ul style="list-style-type: none"> <li>Overhead bin with lift-up door: paint price group 1</li> <li>Recess beneath unit to accommodate shelf light</li> <li>Shelf backstop</li> <li>On-module attachment brackets with safety catch: black paint only</li> <li>Off-module attachment brackets, if selected: black paint only</li> <li>Lock, keyed random: 9201 Polished Chrome</li> </ul>	<ol style="list-style-type: none"> <li>Style number</li> <li>Paint color number for overhead bin</li> <li>Options, if selected (see below)</li> </ol> <p>▶ See <i>Surface Materials</i>, page 360.</p>

	Options	U.S. Price	Required to Specify	
<b>Surface Materials</b>	<b>Overhead bin with one door</b>			
	<ul style="list-style-type: none"> <li>Paint price group 1</li> <li>Paint price group 2</li> <li>Paint price group 3</li> </ul>	<ul style="list-style-type: none"> <li>No cost</li> <li>+\$ 65</li> <li>+\$111</li> </ul>	<ul style="list-style-type: none"> <li>Specify paint color number.</li> <li>Specify paint color number.</li> <li>Specify paint color number.</li> </ul>	
	<b>Overhead bin with two doors</b>			
	<ul style="list-style-type: none"> <li>Paint price group 1</li> <li>Paint price group 2</li> <li>Paint price group 3</li> </ul>	<ul style="list-style-type: none"> <li>No cost</li> <li>+\$ 88</li> <li>+\$155</li> </ul>	<ul style="list-style-type: none"> <li>Specify paint color number.</li> <li>Specify paint color number.</li> <li>Specify paint color number.</li> </ul>	
<b>Brackets</b>	<b>Off-module attachment brackets</b>			
	<ul style="list-style-type: none"> <li>One vertical off-module bracket</li> <li>Two vertical off-module brackets</li> </ul>	<ul style="list-style-type: none"> <li>+\$ 98</li> <li>+\$196</li> </ul>	<ul style="list-style-type: none"> <li>Specify <i>with one vertical off-module bracket</i>.</li> <li>Specify <i>with two vertical off-module brackets</i>.</li> </ul>	
	<b>Upmount brackets</b>	<ul style="list-style-type: none"> <li>Upmount kit</li> </ul>	<ul style="list-style-type: none"> <li>+\$288</li> </ul>	<ul style="list-style-type: none"> <li>Specify <i>with upmount kit</i>.</li> </ul>
	<b>No brackets</b>	<ul style="list-style-type: none"> <li>Omit brackets</li> </ul>	<ul style="list-style-type: none"> <li>-\$ 31</li> </ul>	<ul style="list-style-type: none"> <li>Specify <i>omit brackets</i>.</li> </ul>
	<b>Picture Frame Door on Flat Fronts</b>	<ul style="list-style-type: none"> <li>Omit insert</li> </ul>	<ul style="list-style-type: none"> <li>Prices at right</li> </ul>	<ul style="list-style-type: none"> <li>Specify <i>omit insert</i>.</li> </ul>
	<b>Door Mechanism</b>	<ul style="list-style-type: none"> <li>Assist mechanism</li> </ul>	<ul style="list-style-type: none"> <li>+\$288 per door</li> </ul>	<ul style="list-style-type: none"> <li>Specify <i>with assist mechanism</i>.</li> </ul>
	<b>Shelf Accessories</b>	<ul style="list-style-type: none"> <li>Four dividers: white plastic</li> </ul>	<ul style="list-style-type: none"> <li>+\$ 76</li> </ul>	<ul style="list-style-type: none"> <li>Specify <i>with dividers</i>.</li> </ul>
	<b>Lock and Keying</b>	<ul style="list-style-type: none"> <li><b>Lock</b></li> <li>No lock</li> <li>Ember Chrome</li> </ul>	<ul style="list-style-type: none"> <li>-\$104 per door</li> <li>No cost</li> </ul>	<ul style="list-style-type: none"> <li>Specify <i>with no lock</i>.</li> <li>Specify <i>with 9250 Ember Chrome lock</i>.</li> </ul>
		<ul style="list-style-type: none"> <li><b>Keying</b></li> <li>Factory- and field-installed keying</li> </ul>		<ul style="list-style-type: none"> <li>▶ Page 375</li> </ul>
<b>Related Products</b>	<ul style="list-style-type: none"> <li>Accessories</li> <li>Shelf lights</li> </ul>			<ul style="list-style-type: none"> <li>▶ Page 304</li> <li>▶ Page 352</li> </ul>

Tip: Upmount brackets include steel back to enclose storage bin.

Tip: When ordering the omit insert option, remember that custom material cannot be factory installed. Custom material must be ordered from a material vendor.

Tip: Overhead storage bins and shelves with a "TAK" suffix can be used with Privacy Wall as well.  
▶ See *Architectural Solutions Specification Guide* for attachment information.



**For Canadian Pricing**  
Multiply U.S. Price by the Canadian price factor.  
▶ See page 1 for details.

**Specification Information**

• Dimensions			• Number of Doors	• Style Number	• U.S. Base Price	• Option (Add \$ to Base Price) Picture Frame Door—Omit Insert
D	W	H				

**Bins with Flat Fronts**

15¾"	24"	16¼"	1	<b>RBB24QTAK</b>	\$ 941	+\$403
15¾"	30"	16¼"	1	<b>RBB30QTAK</b>	\$ 979	+\$425
15¾"	36"	16¼"	1	<b>RBB36QTAK</b>	\$1026	+\$447
15¾"	42"	16¼"	1	<b>RBB42QTAK</b>	\$1063	+\$464
15¾"	48"	16¼"	1	<b>RBB48QTAK</b>	\$1098	+\$484
15¾"	60"	16¼"	2	<b>RBB60QTAK</b>	\$1761	+\$795
15¾"	66"	16¼"	2	<b>RBB66QTAK</b>	\$1848	+\$813
15¾"	72"	16¼"	2	<b>RBB72QTAK</b>	\$1915	+\$831

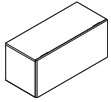

Tip: Overhead storage bins and shelves with a "TAK" suffix can be used with Privacy Wall as well.

► See Architectural Solutions Specification Guide for attachment information.



**For Canadian Pricing**

Multiply U.S. Price by the Canadian price factor.

► See page 1 for details.

# Universal In the Case Bins with Steel, Laminate, or Wood Flat Fronts

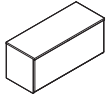

Standard Includes	Required to Specify
<ul style="list-style-type: none"> <li>▶ Need help? Product details, page 148</li> <li>• Overhead bin with lift-up door: paint price group 1</li> <li>• Door on units with laminate door fronts: laminate price group 1</li> <li>• Door on units with wood door fronts: wood group 1</li> <li>• Recess beneath unit to accommodate shelf light</li> <li>• Shelf backstop</li> <li>• On-module attachment brackets with safety catch: black paint only</li> <li>• Off-module attachment brackets, if selected: black paint only</li> <li>• Lock, keyed random: 9201 Polished Chrome</li> </ul>	<ol style="list-style-type: none"> <li>1 Style number</li> <li>2 Paint color number for overhead bin</li> <li>3 Laminate color number for door, if laminate door selected</li> <li>4 Wood color number for door, if wood door selected</li> <li>5 Options, if selected (see below)                     <ul style="list-style-type: none"> <li>▶ See <i>Surface Materials</i>, page 360.</li> </ul> </li> </ol>

Surface Materials	Options	U.S. Price	Required to Specify	
	<b>Overhead bin with one steel door</b>			
	• Paint price group 1	No cost	Specify paint color number.	
	• Paint price group 2	+\$ 65	Specify paint color number.	
	• Paint price group 3	+\$111	Specify paint color number.	
	<b>Overhead bin with two steel doors</b>			
	• Paint price group 1	No cost	Specify paint color number.	
	• Paint price group 2	+\$ 88	Specify paint color number.	
	• Paint price group 3	+\$155	Specify paint color number.	
	<b>Overhead bin with one laminate or wood door</b>			
	• Paint price group 1	No cost	Specify paint color number.	
	• Paint price group 2	+\$ 65	Specify paint color number.	
	• Paint price group 3	+\$101	Specify paint color number.	
• Laminate price group 1 on laminate door	Prices at right	Specify laminate color number.		
• Laminate price group 2 on laminate door	See information at left	Specify laminate color number.		
• Laminate price group 3 on laminate door	See information at left	Specify laminate color number.		
• Open Line laminate on laminate door	+\$102 plus cost of laminate	▶ See <i>Surface Materials Reference Manual</i> .		
• Wood group 2 on wood door	See information at left	Specify wood color number.		
• Wood group 3 on wood door	See information at left	Specify wood color number.		
• Customiz stain on wood door	No cost	Specify <i>with Customiz stain</i> .		
		▶ See <i>Surface Materials Reference Manual</i> .		
<b>Overhead bin with two laminate or wood doors</b>				
• Paint price group 1	No cost	Specify paint color number.		
• Paint price group 2	+\$ 88	Specify paint color number.		
• Paint price group 3	+\$135	Specify paint color number.		
• Laminate price group 1 on laminate doors	Prices at right	Specify laminate color number.		
• Laminate price group 2 on laminate doors	See information at left	Specify laminate color number.		
• Laminate price group 3 on laminate doors	See information at left	Specify laminate color number.		
• Open Line laminate on laminate doors	+\$102 plus cost of laminate	▶ See <i>Surface Materials Reference Manual</i> .		
• Wood group 2 on wood doors	See information at left	Specify wood color number.		
• Wood group 3 on wood doors	See information at left	Specify wood color number.		
• Customiz stain on wood doors	No cost	Specify <i>with Customiz stain</i> .		
		▶ See <i>Surface Materials Reference Manual</i> .		

▶ Options, continued on next page

 **For Canadian Pricing**  
 Multiply U.S. Price by the Canadian price factor.  
 ▶ See page 1 for details.

► Options, continued from previous page

Tip: Upmount brackets include steel back to enclose storage bin.

Tip: When ordering the omit insert option, remember that custom material cannot be factory installed. Custom material must be ordered from a material vendor.

Tip: Overhead storage bins and shelves with a "TAK" suffix can be used with Privacy Wall as well.  
► See Architectural Solutions Specification Guide for attachment information.

Options	U.S. Price	Required to Specify
<b>Brackets</b>	<b>Off-module attachment brackets</b>	
• One vertical off-module bracket	+\$ 98	Specify with one vertical off-module bracket.
• Two vertical off-module brackets	+\$196	Specify with two vertical off-module brackets.
	<b>Upmount brackets</b>	
• Upmount kit	+\$288	Specify with upmount kit.
	<b>No brackets</b>	
• Omit brackets	-\$ 31	Specify omit brackets.
<b>Picture Frame Door on Flat Fronts</b>	• Omit insert	Prices at right Specify omit insert.
<b>Door Mechanism</b>	• Assist mechanism	+\$288 per door Specify with assist mechanism.
<b>Shelf Accessories</b>	• Four dividers: white plastic	+\$ 76 Specify with dividers.
<b>Lock and Keying</b>	<b>Lock</b>	
	• No lock	-\$104 per door Specify with no lock.
	• Ember Chrome	No cost Specify with 9250 Ember Chrome lock.
	<b>Keying</b>	
	• Factory- and field-installed keying	► Page 375
<b>Related Products</b>	• Accessories	► Page 304
	• Shelf lights	► Page 352

Specification Information

Dimensions			Number of Doors	Style Number	U.S. Base Price	Option (Add \$ to Base Price)
D	W	H				
						Picture Frame Door—Omit Insert

Bins with Steel Flat Fronts

15¾"	24"	16¼"	1	<b>RBB24TAK</b>	\$ 941	+\$403
15¾"	30"	16¼"	1	<b>RBB30TAK</b>	\$ 979	+\$425
15¾"	36"	16¼"	1	<b>RBB36TAK</b>	\$1026	+\$447
15¾"	42"	16¼"	1	<b>RBB42TAK</b>	\$1063	+\$464
15¾"	48"	16¼"	1	<b>RBB48TAK</b>	\$1098	+\$484
15¾"	60"	16¼"	2	<b>RBB60TAK</b>	\$1761	+\$795
15¾"	66"	16¼"	2	<b>RBB66TAK</b>	\$1848	+\$813
15¾"	72"	16¼"	2	<b>RBB72TAK</b>	\$1915	+\$831

► Specification Information, continued on next page

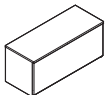

Tip: Overhead storage bins and shelves with a "TAK" suffix can be used with Privacy Wall as well.

► See Architectural Solutions Specification Guide for attachment information.



**For Canadian Pricing**

Multiply U.S. Price by the Canadian price factor.

► See page 1 for details.

► **Specification Information, continued from previous page**

**Specification Information**

• Dimensions			• Number of Doors	• Style Number	• U.S. Base Price
D	W	H			

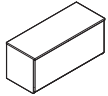

**Bins with Laminate Flat Fronts**

15¾"	24"	16¼"	1	<b>RBB24LTAK</b>	\$1493
15¾"	30"	16¼"	1	<b>RBB30LTAK</b>	\$1531
15¾"	36"	16¼"	1	<b>RBB36LTAK</b>	\$1578
15¾"	42"	16¼"	1	<b>RBB42LTAK</b>	\$1615
15¾"	48"	16¼"	1	<b>RBB48LTAK</b>	\$1650
15¾"	60"	16¼"	2	<b>RBB60LTAK</b>	\$2760
15¾"	66"	16¼"	2	<b>RBB66LTAK</b>	\$2847
15¾"	72"	16¼"	2	<b>RBB72LTAK</b>	\$2914

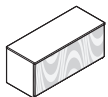

**Bins with Wood Flat Fronts**

15¾"	24"	16¼"	1	<b>RBB24WTAK</b>	\$1537
15¾"	30"	16¼"	1	<b>RBB30WTAK</b>	\$1575
15¾"	36"	16¼"	1	<b>RBB36WTAK</b>	\$1622
15¾"	42"	16¼"	1	<b>RBB42WTAK</b>	\$1659
15¾"	48"	16¼"	1	<b>RBB48WTAK</b>	\$1694
15¾"	60"	16¼"	2	<b>RBB60WTAK</b>	\$2804
15¾"	66"	16¼"	2	<b>RBB66WTAK</b>	\$2891
15¾"	72"	16¼"	2	<b>RBB72WTAK</b>	\$2958



**For Canadian Pricing**

Multiply U.S. Price by the Canadian price factor.

► See page 1 for details.

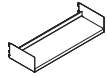

Standard Includes		Required to Specify
▶ Need help? Product details, page 152	<ul style="list-style-type: none"> <li>Shelf: paint price group 1</li> <li>Recess beneath unit to accommodate shelf light</li> <li>Shelf backstop</li> <li>On-module attachment hooks with safety catch</li> </ul>	1 Style number 2 Paint color number for shelf 3 Options, if selected (see below) ▶ See <i>Surface Materials</i> , page 360.

Options	U.S. Price	Required to Specify
<b>Surface Materials</b>	<ul style="list-style-type: none"> <li>Paint price group 1: No cost</li> <li>Paint price group 2: +\$22</li> <li>Paint price group 3: +\$36</li> </ul>	Specify paint color number. Specify paint color number. Specify paint color number.

<b>Related Products</b>	<ul style="list-style-type: none"> <li>Accessories</li> <li>Shelf lights</li> </ul>	▶ Page 304 ▶ Pages 352–356
-------------------------	---	-------------------------------

### Specification Information

Dimensions			Style Number	U.S. Base Price
D	W	H		
14¾"	24"	7½"	<b>RSH24TAK</b>	\$307
14¾"	30"	7½"	<b>RSH30TAK</b>	\$322
14¾"	36"	7½"	<b>RSH36TAK</b>	\$340
14¾"	42"	7½"	<b>RSH42TAK</b>	\$362
14¾"	48"	7½"	<b>RSH48TAK</b>	\$391
14¾"	60"	7½"	<b>RSH60TAK</b>	\$435
14¾"	72"	7½"	<b>RSH72TAK</b>	\$484

*Tip: Overhead storage bins and shelves with a "TAK" suffix can be used with Privacy Wall as well.*  
 ▶ See *Architectural Solutions Specification Guide* for attachment information.

 **For Canadian Pricing**  
 Multiply U.S. Price by the Canadian price factor.  
 ▶ See page 1 for details.

# Accessories For Universal Bins and Shelves

## Horizontal Wall Attachment Brackets

For Use with Universal Sliding Door, Universal Over the Case, and Universal In the Case Bins

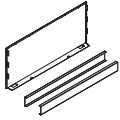

Standard Includes		Required to Specify
<ul style="list-style-type: none"> <li>▶ Need help? Product details, page 155</li> </ul>	<ul style="list-style-type: none"> <li>• Brackets: paint price group 1</li> <li>• Steel back to enclose storage bin: paint price group 1</li> </ul>	<ul style="list-style-type: none"> <li>1 Style number</li> <li>2 Paint color number for brackets and back</li> <li>3 Options, if selected (see below)</li> <li>▶ See <i>Surface Materials</i>, page 360.</li> </ul>

Options	U.S. Price	Required to Specify
<b>Surface Materials</b> <ul style="list-style-type: none"> <li>• Paint price group 1</li> <li>• Paint price group 2</li> <li>• Paint price group 3</li> </ul>	<ul style="list-style-type: none"> <li>No cost</li> <li>+\$22</li> <li>+\$36</li> </ul>	<ul style="list-style-type: none"> <li>Specify paint color number.</li> <li>Specify paint color number.</li> <li>Specify paint color number.</li> </ul>

Specification Information		
Width	Style Number	U.S. Base Price
24"	<b>RBKHWM24</b>	\$335
30"	<b>RBKHWM30</b>	\$335
36"	<b>RBKHWM36</b>	\$335
42"	<b>RBKHWM42</b>	\$335
48"	<b>RBKHWM48</b>	\$335
60"	<b>RBKHWM60</b>	\$335
70"	<b>RBKHWM70</b>	\$335
72"	<b>RBKHWM72</b>	\$335

## Dividers

For Use with Universal Sliding Door, Universal Over the Case, Universal In the Case, and Universal Shelves



Standard Includes		Required to Specify
<ul style="list-style-type: none"> <li>▶ Need help? Product details, page 154</li> </ul>	<ul style="list-style-type: none"> <li>• Package of four dividers: white plastic only</li> </ul>	<ul style="list-style-type: none"> <li>Style number</li> </ul>

Specification Information	
Style Number	U.S. Price
<b>RDIV</b>	\$76



**For Canadian Pricing**  
 Multiply U.S. Price by the Canadian price factor.  
 ▶ See page 1 for details.

## Universal Vertical Off-Module Bracket

For Use with Universal Sliding Door, Universal Over the Case, and Universal In the Case Bins



*Tip: For two-sided, off-module application, order two vertical off-module brackets.*

*Tip: Vertical off-module brackets are used with panels which have vertical slot patterns including Answer, Kick, Avenir, and Montage.*

*Tip: For Montage, vertical off-module brackets can be used with 30"W to 60"W bins only.*

Standard Includes		Required to Specify
▶ Need help? Product details, page 148	<ul style="list-style-type: none"> <li>Vertical off-module bracket with safety catch: black paint only</li> </ul>	Style number

Specification Information	
Style Number	U.S. Price
<b>RBKVOFM</b>	\$95

## Standard Overhead Upmount Packages

For Use on Kick Panels

For Use with Universal Sliding Door, Universal Over the Case, and Universal In the Case Bins

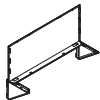

Standard Includes		Required to Specify
▶ Need help? Product details, page 149	<ul style="list-style-type: none"> <li>Pair of steel upmount brackets: paint price group 1</li> <li>Steel back to enclose storage bin</li> </ul>	1 Style number 2 Paint color number for brackets and back 3 Options, if selected (see below) ▶ See <i>Surface Materials</i> , page 360.

Options	U.S. Price	Required to Specify
<b>Surface Materials</b>	<ul style="list-style-type: none"> <li>Paint price group 1</li> <li>Paint price group 2</li> <li>Paint price group 3</li> </ul>	No cost +\$22 +\$36 Specify paint color number. Specify paint color number. Specify paint color number.

Specification Information		
Width	Style Number	U.S. Base Price

### For Use with Answer and Kick

24"	<b>RUK24TAK</b>	\$286
30"	<b>RUK30TAK</b>	\$286
36"	<b>RUK36TAK</b>	\$286
42"	<b>RUK42TAK</b>	\$286
48"	<b>RUK48TAK</b>	\$286
60"	<b>RUK60TAK</b>	\$286
72"	<b>RUK72TAK</b>	\$286



### For Canadian Pricing

Multiply U.S. Price by the Canadian price factor.

▶ See page 1 for details.

## Wall Channels for TS Series Bins, Universal Bins, and Universal Shelves

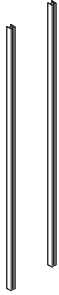

Standard Includes	Required to Specify
-------------------	---------------------

- |  |   |  |
|--|---|--|
| <ul style="list-style-type: none"> <li>▶ Need help? Product details, page 156</li> </ul> | <ul style="list-style-type: none"> <li>• Pair of channels: paint</li> </ul> | <ul style="list-style-type: none"> <li>1 Style number</li> <li>2 Paint color number for channels</li> <li>▶ See <i>Surface Materials</i>, page 360.</li> </ul> |
|--|---|--|

Related Products
------------------

- |  |  |
|--|--|
| <ul style="list-style-type: none"> <li>• Tackboard for use with wall channels</li> </ul> | <ul style="list-style-type: none"> <li>▶ Page 307</li> </ul> |
|--|--|

Specification Information		
---------------------------	--	--

• Height	• Style Number	• U.S. Price
66"	<b>TS7BSWHC</b>	\$183

## Wall Channel Horizontal Braces

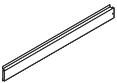

Standard Includes	Required to Specify
-------------------	---------------------

- |  |  |  |
|--|--|--|
| <ul style="list-style-type: none"> <li>▶ Need help? Product details, page 156</li> </ul> | <ul style="list-style-type: none"> <li>• Brace: paint</li> </ul> | <ul style="list-style-type: none"> <li>1 Style number</li> <li>2 Paint color number for horizontal brace</li> <li>▶ See <i>Surface Materials</i>, page 360.</li> </ul> |
|--|--|--|

Specification Information		
---------------------------	--	--

• Width	• Style Number	• U.S. Price
42"	<b>TS742HB</b>	\$133
48"	<b>TS748HB</b>	\$133
60"	<b>TS760HB</b>	\$133
72"	<b>TS772HB</b>	\$133



**For Canadian Pricing**  
 Multiply U.S. Price by the Canadian price factor.  
 ▶ See page 1 for details.

## Tackboards for Use with Wall Channels

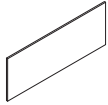

Standard Includes	Required to Specify
-------------------	---------------------

- |   |  |
|---|--|
| <ul style="list-style-type: none"> <li>Tackboard, fabric direction with horizontal application: fabric price group 1</li> </ul> | <ul style="list-style-type: none"> <li>1 Style number</li> <li>2 Fabric color number</li> <li>3 Options, if selected (see below)</li> <li>▶ See <i>Surface Materials</i>, page 360.</li> </ul> |
|---|--|

Options	U.S. Price	Required to Specify
---------	------------	---------------------

- |   |  |  |
|---|--|--|
| <b>Surface Materials</b> <ul style="list-style-type: none"> <li>Fabric price group 1</li> <li>Fabric price group 2</li> <li>Fabric price group 3</li> <li>Fabric price group 4</li> <li>Fabric price group 5</li> <li>Fabric price group COM</li> </ul> | <ul style="list-style-type: none"> <li>No cost</li> <li>+\$21</li> <li>+\$39</li> <li>+\$57</li> <li>+\$87</li> <li>+\$55</li> </ul> | <ul style="list-style-type: none"> <li>Specify fabric color number.</li> <li>Specify fabric color number.</li> <li>Specify fabric color number.</li> <li>Specify fabric color number.</li> <li>Specify fabric color number.</li> </ul> |
|---|--|--|

**Fabric direction on 24"W to 60"W tackboards**

- |  |   |  |
|--|---|--|
| <ul style="list-style-type: none"> <li>Vertical application</li> </ul> | <ul style="list-style-type: none"> <li>No cost</li> </ul> | <ul style="list-style-type: none"> <li>Specify with vertical application.</li> </ul> |
|--|---|--|

- |  |  |
|--|--|
| <b>Related Products</b> <ul style="list-style-type: none"> <li>Wall channels for Universal bins and shelves</li> </ul> | <ul style="list-style-type: none"> <li>▶ Page 306</li> </ul> |
|--|--|

Tip: 72"W tackboards accommodate fabric in the horizontal direction only.

Tip: For further information about fabric direction, ▶ Page 365.

### Specification Information

Dimensions		Style Number	U.S. Base Price
W	H		
24"	18"	<b>TS71824TB</b>	\$207
30"	18"	<b>TS71830TB</b>	\$229
36"	18"	<b>TS71836TB</b>	\$251
42"	18"	<b>TS71842TB</b>	\$275
48"	18"	<b>TS71848TB</b>	\$307
60"	18"	<b>TS71860TB</b>	\$389
72"	18"	<b>TS71872TB</b>	\$477

## Flexible Markerboard Surface

For Use with Universal Over the Case Bins

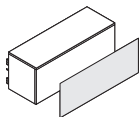

Standard Includes	Required to Specify
-------------------	---------------------

- |   |  |
|---|--|
| <ul style="list-style-type: none"> <li>Flexible, magnetic markerboard surface to attach to door of overhead storage bin: white plastic</li> </ul> | <ul style="list-style-type: none"> <li>Style number</li> </ul> |
|---|--|

### Specification Information

Dimensions		Style Number	U.S. Price
W	H		
30"	16¼"	<b>R30MBB</b>	\$177
36"	16¼"	<b>R36MBB</b>	\$187
42"	16¼"	<b>R42MBB</b>	\$193
48"	16¼"	<b>R48MBB</b>	\$205



**For Canadian Pricing**  
Multiply U.S. Price by the Canadian price factor.  
▶ See page 1 for details.

# Slim Shelves

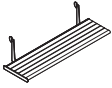

Standard Includes		Required to Specify
▶ Need help? Product details, page 157	<ul style="list-style-type: none"> <li>Shelf: paint price group 1</li> <li>Attachment brackets: paint to match shelf</li> </ul>	1 Style number 2 Paint color number for shelf 3 Options, if selected (see below) ▶ See <i>Surface Materials</i> , page 360.

Options	U.S. Price	Required to Specify
<b>Surface Materials</b>	<ul style="list-style-type: none"> <li>Paint price group 1</li> <li>Paint price group 2</li> <li>Paint price group 3</li> </ul>	No cost +\$22 +\$36

Specification Information			
Dimensions		Style Number	U.S. Base Price
D	W		
6"	24"	<b>RSS24TAK</b>	\$319
6"	30"	<b>RSS30TAK</b>	\$340
6"	36"	<b>RSS36TAK</b>	\$364
6"	42"	<b>RSS42TAK</b>	\$391
6"	48"	<b>RSS48TAK</b>	\$416
6"	60"	<b>RSS60TAK</b>	\$521
6"	72"	<b>RSS72TAK</b>	\$570
6"	96"	<b>RSS96TAK</b>	\$671
:	:	:	:

Tip: Slim shelves with a "TAK" suffix can attach to Privacy Wall.  
 ▶ See *Architectural Solutions Specification Guide* for attachment information.



**For Canadian Pricing**  
 Multiply U.S. Price by the Canadian price factor.  
 ▶ See page 1 for details.



# Universal One-High, 1.5-High, and Two Drawer Lateral Files

with Flush Steel, Proud Steel, Proud Laminate, Proud Wood, or Open Fronts

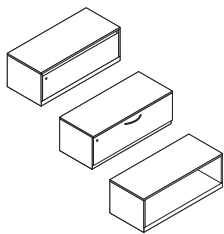

Tip: Service part Y30291SR, (paintable black plug), can be ordered to cover the glide adjustment holes in the front of the lateral file.

Standard Includes		Required to Specify
-------------------	--	---------------------

- |  |  |  |
|--|--|--|
| <ul style="list-style-type: none"> <li>▶ Need help? Product details, page 162</li> </ul> | <ul style="list-style-type: none"> <li>Lateral file: paint price group 1</li> <li>1"H top on units with flush steel or proud steel fronts: paint to match file</li> <li>Drawer fronts on units with proud laminate fronts: laminate price group 1</li> <li>Drawer fronts on units with proud wood fronts: wood group 1 veneer</li> <li>Base (see below under Required Selections)</li> <li>Pulls: metal</li> <li>Integral pulls on units with flush steel fronts</li> <li>Central lock, keyed random: 9201 Polished Chrome</li> <li>One label holder per drawer: clear plastic</li> <li>Drawer body: black only</li> <li>Drawer suspensions: black only</li> <li>One hanging folder bar per drawer on 18"D units</li> <li>Two rails per drawer on 24"D units</li> <li>Four adjustable leveling glides</li> <li>Ganging hardware</li> <li>Counterweight package, if selected</li> </ul> | <ol style="list-style-type: none"> <li>Style number with appropriate front style suffix in the space provided                     <ul style="list-style-type: none"> <li><b>F</b> Flush steel front</li> <li><b>P</b> Proud steel front</li> <li><b>L</b> Proud laminate front</li> <li><b>W</b> Proud wood front</li> </ul> </li> <li>Paint color number for file</li> <li>Laminate color number for fronts, if proud laminate front selected</li> <li>Wood color number for fronts, if proud wood front selected</li> <li>Base (see below under Required Selections)</li> <li>Pull (see below under Required Selections)</li> <li>Metal color number for pulls, if proud steel, proud laminate, or proud wood front selected</li> <li>Options, if selected (see below)                     <ul style="list-style-type: none"> <li>▶ See <i>Surface Materials</i>, page 360.</li> </ul> </li> </ol> |
|--|--|--|

Required Selections	U.S. Price	Required to Specify
---------------------	------------	---------------------

<b>Bases</b>	<ul style="list-style-type: none"> <li>Universal 3" base</li> <li>FrameOne foot base</li> <li>c:scape glide base</li> </ul>	<ul style="list-style-type: none"> <li>No cost</li> <li>+\$144</li> <li>+\$144</li> </ul> <p>Specify with <i>Universal 3" base</i>, painted to match tower. Specify with <i>FrameOne foot base</i>, painted to match tower. Specify with <i>c:scape glide base</i>, 4799 Platinum only.</p>
--------------	---	---

### Pulls

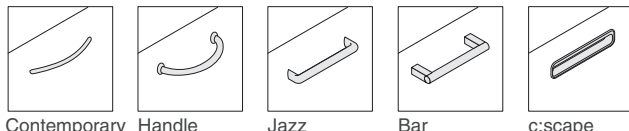

Options	U.S. Price	Required to Specify
---------	------------	---------------------

<b>Surface Materials</b>	<ul style="list-style-type: none"> <li>Paint price group 1</li> <li>Paint price group 2</li> <li>Paint price group 3</li> </ul>	<ul style="list-style-type: none"> <li>No cost</li> <li>+\$111</li> <li>+\$192</li> </ul> <p>Specify paint color number. Specify paint color number. Specify paint color number.</p>
	<ul style="list-style-type: none"> <li>Laminate price group 1 on proud laminate drawer fronts</li> <li>Laminate price group 2 on proud laminate drawer fronts</li> <li>Laminate price group 3 on proud laminate drawer fronts</li> <li>Open Line laminate on proud laminate drawer fronts</li> </ul>	<ul style="list-style-type: none"> <li>Prices at right</li> <li>See information at left</li> <li>See information at left</li> <li>+\$102 plus cost of laminate</li> </ul> <p>Specify laminate color number. Specify laminate color number. Specify laminate color number. ▶ See <i>Surface Materials Reference Manual</i>.</p>
	<ul style="list-style-type: none"> <li>Wood group 2 on proud wood drawer fronts</li> <li>Wood group 3 on proud wood drawer fronts</li> <li>Customiz stain on proud wood drawer fronts</li> </ul>	<ul style="list-style-type: none"> <li>See information at left</li> <li>See information at left</li> <li>No cost</li> </ul> <p>Specify wood color number. Specify wood color number. Specify with <i>Customiz stain</i>. ▶ See <i>Surface Materials Reference Manual</i>.</p>

For wood and laminate group 2 and 3 pricing, please refer to the electronic catalog or SmartTools.

Tip: Security top reduces overall height by approximately 1".

Tip: Laminate and wood veneer tops are 3/16" taller than other tops and will add 3/16" to overall case height.

<b>Tops for Flush Steel Front and Proud Steel Front</b>	<ul style="list-style-type: none"> <li><b>Security top</b></li> <li>For use on 28"H lateral files only</li> <li><b>No top</b></li> <li>For use with a cushion top or beneath a common top</li> </ul>	<ul style="list-style-type: none"> <li>No cost</li> <li>-\$147</li> </ul> <p>Specify with <i>security top</i>. Specify with <i>no top</i>.</p>
---	--	--

▶ Options, continued on next page

► Options, continued from previous page

	Options	U.S. Price	Required to Specify
<b>Tops for Flush Steel Front and Proud Steel Front, continued</b>	<b>Laminate top</b>		
	• Square edge laminate price group 1 top	+\$205	Specify <i>with laminate top</i> and indicate laminate color number for top and plastic color number for edges.
	• Square edge laminate price group 2 top	See information at left	Specify <i>with laminate top</i> and indicate laminate color number for top and plastic color number for edges.
	• Square edge laminate price group 3 top	See information at left	Specify <i>with laminate top</i> and indicate laminate color number for top and plastic color number for edges.
	• Open Line laminate on laminate top	+\$102 plus cost of laminate	► See <i>Surface Materials Reference Manual</i> .
	<b>Wood veneer top</b>		
	• Wood group 1	+\$619	Specify <i>with wood veneer top</i> and indicate wood color number.
	• Wood group 2	See information at left	Specify <i>with wood veneer top</i> and indicate wood color number.
	• Wood group 3	See information at left	Specify <i>with wood veneer top</i> and indicate wood color number.
	• Customiz stain on wood veneer top	No cost	Specify <i>with Customiz stain</i> . ► See <i>Surface Materials Reference Manual</i> .
<b>Tops for Proud Wood Front</b>	<b>Security top</b>		
	• For use on 28"H lateral files only	-\$619	Specify <i>with security top</i> .
	<b>No top</b>		
	• For use with a cushion top or beneath a common top	-\$766	Specify <i>with no top</i> .
	<b>Laminate top</b>		
	• Square edge laminate price group 1 top	-\$414	Specify <i>with laminate top</i> and indicate laminate color number for top and plastic color number for edges.
	• Square edge laminate price group 2 top	See information at left	Specify <i>with laminate top</i> and indicate laminate color number for top and plastic color number for edges.
	• Square edge laminate price group 3 top	See information at left	Specify <i>with laminate top</i> and indicate laminate color number for top and plastic color number for edges.
	• Open Line laminate on laminate top	+\$102 plus cost of laminate	► See <i>Surface Materials Reference Manual</i> .
	<b>Wood veneer top</b>		
• Wood group 2 on proud wood top	See information at left	Specify wood color number.	
• Wood group 3 on proud wood top	See information at left	Specify wood color number.	
• Customiz stain on proud wood top	No cost	Specify <i>with Customiz stain</i> . ► See <i>Surface Materials Reference Manual</i> .	
<b>Tops for Proud Laminate Front</b>	<b>Security top</b>		
	• For use on 28"H lateral files only	-\$206	Specify <i>with security top</i> .
	<b>No top</b>		
	• For use with a cushion top or beneath a common top	-\$414	Specify <i>with no top</i> .
	<b>Laminate top</b>		
• Open Line laminate on laminate top	+\$102 plus cost of laminate	► See <i>Surface Materials Reference Manual</i> .	

► Options, continued on next page

**For wood and laminate group 2 and 3 pricing, please refer to the electronic catalog or SmartTools.**

*Tip: Full-fill finish (option) is available on field-installed tops only.*

► See *Storage specification guide*.



**For Canadian Pricing**

Multiply U.S. Price by the Canadian price factor.

► See page 1 for details.

Universal One-High, 1.5-High, and Two Drawer Lateral Files with Flush Steel, Proud Steel, Proud Laminate, Proud Wood, or Open Fronts, continued

► Options, continued from previous page

	Options	U.S. Price	Required to Specify
<b>Tops for Proud Laminate Front, continued</b>	<b>Wood veneer top</b>		
	• Wood group 1 on proud top	+\$352	Specify with wood veneer top and indicate wood color number.
	• Wood group 2 on proud top	See information at left	Specify with wood veneer top and indicate wood color number.
	• Wood group 3 on proud top	See information at left	Specify with wood veneer top and indicate wood color number.
	• Customiz stain on proud top	No cost	Specify with Customiz stain. ► See Surface Materials Reference Manual.
<b>Drawer Interiors</b>	• HF bar for use on 24"D units only	+\$ 22	Specify with HF bar.
	• Divider package	+\$ 40	Specify with divider package.
	• Rails for use on 18"D units only	+\$ 51	Specify with rails.
<b>Pulls</b>	<b>Proud steel, laminate, or wood fronts</b>		
	• Contemporary	No cost	Specify with contemporary pull.
	• Handle	No cost	Specify with handle pull.
	• Jazz	+\$ 28 per pull	Specify with jazz pull.
	• Bar	+\$ 43 per pull	Specify with bar pull.
	<b>Proud steel fronts only</b>		
	• c:scape	+\$ 48 per pull	Specify with c:scape pull.
<b>Counterweights</b>	<b>One-High and 1.5-High lateral files with Universal 3" base</b>		
	• Package 30	+\$329	Specify with counterweight.
	• Package 36	+\$329	Specify with counterweight.
	• Package 42	+\$329	Specify with counterweight.
	• Package D	+\$180	Specify with counterweight.
	• Package E	+\$235	Specify with counterweight.
	• Package F	+\$329	Specify with counterweight.
	<b>One-High and 1.5-High lateral files with c:scape glide and FrameOne foot bases</b>		
	• Package 30	+\$329	Specify with counterweight.
	• Package 36	+\$329	Specify with counterweight.
	• Package 42	+\$329	Specify with counterweight.
	<b>Two Drawer with Universal 3" bases</b>		
	• Package 3	+\$180	Specify with counterweight.
	• Package 4	+\$235	Specify with counterweight.
	<b>Two Drawer with c:scape glide and FrameOne foot bases</b>		
• Package 7	+\$329	Specify with counterweight.	
• Package 8	+\$329	Specify with counterweight.	
<b>Lock and Keying</b>	<b>Lock</b>		
	• Ember Chrome	No cost	Specify with 9250 Ember Chrome lock.
	<b>Individual locking drawers</b>		
	• 18" with two drawers	+\$196	Specify with individual lock.
	• 24" with two drawers	+\$220	Specify with individual lock.
	<b>Keying</b>		
	• Factory- and field-installed keying		► Page 375
<b>Related Products</b>	• Low storage-to-beam tether bracket		► Page 315
	• Field-installed tops		► See Storage Specification Guide.
	• Steel storage accessories		► Page 332
	• Bookends		► See Storage Specification Guide.
	• Counterweight packages		► Page 332
	• Basic cushions enhanced		► Page 316

Tip: 6"H box drawers come standard with a divider package.

Tip: Counterweight packages are required to ensure product stability and are ordered as an option or separately. Product specification pages indicate the correct counterweight package for each style number and any exceptions where counterweights are not required.  
► See Counterweight Requirements for Storage Products, page 111.



**For Canadian Pricing**  
Multiply U.S. Price by the Canadian price factor.  
► See page 1 for details.

Tip: Height dimension listed is for units with 1" top. Overall height will vary if another top is selected.

Tip: Your specification is not complete until you add a suffix to the style number to define the front style (for example, RLF18301\_\_ becomes RLF18301F for flush steel front).

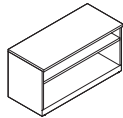
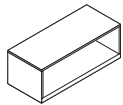
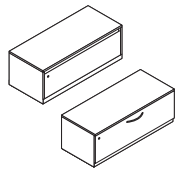

Tip: For open-open units, the shelf is affixed with screws. The screws can be removed to adjust the clips/shelf to a different height.

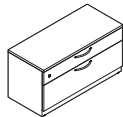

### Specification Information

Dimensions		Counterweight Packages		Style Number	U.S. Base Prices			
D	W H	Universal 3" Base	FrameOne Foot and c:scape Glide Bases		Flush Steel Front	Proud Steel Front	Proud Lam Front	Proud Wood Front
Flush Steel	Proud Steel/Lam/Wood				Suffix F	Suffix P	Suffix L	Suffix W

### One 12"H Drawer

18"	18 <sup>7</sup> / <sub>8</sub> "	30" 16"	Package 30	Package 30	<b>RLF18301</b> __	\$1224	\$1260	\$1669	\$2468
18"	18 <sup>7</sup> / <sub>8</sub> "	36" 16"	Package 36	Package 36	<b>RLF18361</b> __	\$1356	\$1412	\$1812	\$2611
18"	18 <sup>7</sup> / <sub>8</sub> "	42" 16"	Package 42	Package 42	<b>RLF18421</b> __	\$1490	\$1554	\$1946	\$2745

### Open Configurations

18"	18 <sup>7</sup> / <sub>8</sub> "	30" 16"	Not required	Not required	<b>RSC18301A</b> __	\$1051	\$1138	N.A.	N.A.
18"	18 <sup>7</sup> / <sub>8</sub> "	36" 16"	Not required	Not required	<b>RSC18361A</b> __	\$1230	\$1337	N.A.	N.A.
18"	18 <sup>7</sup> / <sub>8</sub> "	42" 16"	Not required	Not required	<b>RSC18421A</b> __	\$1397	\$1514	N.A.	N.A.

### Open-Open Configurations

#### One 6"H Opening with Fixed Shelf and One 12"H Opening with Fixed Shelf

18"	18 <sup>7</sup> / <sub>8</sub> "	30" 22"	Not required	Not required	<b>RLF18301A</b> __	\$1104	\$1197	N.A.	N.A.
18"	18 <sup>7</sup> / <sub>8</sub> "	36" 22"	Not required	Not required	<b>RLF18361A</b> __	\$1327	\$1441	N.A.	N.A.
18"	18 <sup>7</sup> / <sub>8</sub> "	42" 22"	Not required	Not required	<b>RLF18421A</b> __	\$1539	\$1666	N.A.	N.A.
23 <sup>1</sup> / <sub>8</sub> "	24"	30" 22"	Not required	Not required	<b>RLF24301A</b> __	\$1458	\$1576	N.A.	N.A.
23 <sup>1</sup> / <sub>8</sub> "	24"	36" 22"	Not required	Not required	<b>RLF24361A</b> __	\$1741	\$1879	N.A.	N.A.

### Drawer-Drawer Configurations

#### One 6"H Drawer and One 12"H Drawer

18"	18 <sup>7</sup> / <sub>8</sub> "	30" 22"	Package 30	Package 30	<b>RLF18301B</b> __	\$1321	\$1416	\$2042	\$2841
18"	18 <sup>7</sup> / <sub>8</sub> "	36" 22"	Package 36	Package 36	<b>RLF18361B</b> __	\$1549	\$1657	\$2249	\$3048
18"	18 <sup>7</sup> / <sub>8</sub> "	42" 22"	Package 42	Package 42	<b>RLF18421B</b> __	\$1756	\$1885	\$2658	\$3457
23 <sup>1</sup> / <sub>8</sub> "	24"	30" 22"	Package 30	Package 30	<b>RLF24301B</b> __	\$1679	\$1793	\$2619	\$3418
23 <sup>1</sup> / <sub>8</sub> "	24"	36" 22"	Package 36	Package 36	<b>RLF24361B</b> __	\$1961	\$2102	\$2879	\$3678

► Specification Information, continued on next page



#### For Canadian Pricing

Multiply U.S. Price by the Canadian price factor.

► See page 1 for details.

Universal One-High, 1.5-High, and Two Drawer Lateral Files with Flush Steel, Proud Steel, Proud Laminate, Proud Wood, or Open Fronts, continued

► **Specification Information, continued from previous page**

Tip: Height dimension listed is for units with 1" top. Over-all height will vary if another top is selected.

Tip: Your specification is not complete until you add a suffix to the style number to define the front style (for example, RLF18301\_\_ becomes RLF18301F for flush steel front).

Specification Information													
Dimensions		W		H		Counterweight Packages		Style Number		U.S. Base Prices			
Flush Steel	Proud Steel/Lam/Wood					Universal 3" Base	FrameOne Foot and c:scape Glide Bases			Flush Steel Front	Proud Steel Front	Proud Lam Front	Proud Wood Front
										Suffix F	Suffix P	Suffix L	Suffix W

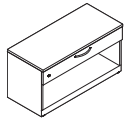

**Drawer-Open Configurations**

**One 6"H Drawer and One 12"H Opening with Fixed Shelf**

18"	18 <sup>7</sup> / <sub>8</sub> "	30"	22"	Package D	Package D	<b>RLF18301C</b> _	\$1223	\$1315	\$1808	\$2607
18"	18 <sup>7</sup> / <sub>8</sub> "	36"	22"	Package E	Package E	<b>RLF18361C</b> _	\$1445	\$1550	\$2015	\$2814
18"	18 <sup>7</sup> / <sub>8</sub> "	42"	22"	Package F	Package F	<b>RLF18421C</b> _	\$1647	\$1775	\$2420	\$3219
23 <sup>1</sup> / <sub>8</sub> "	24"	30"	22"	Package D	Package D	<b>RLF24301C</b> _	\$1567	\$1683	\$2386	\$3185
23 <sup>1</sup> / <sub>8</sub> "	24"	36"	22"	Package E	Package E	<b>RLF24361C</b> _	\$1839	\$1973	\$2646	\$3445

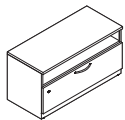

**Open-Drawer Configurations**

**One 6"H Opening with Fixed Shelf and One 12"H Drawer**

18"	18 <sup>7</sup> / <sub>8</sub> "	30"	22"	Package 30	Package 30	<b>RLF18301D</b> _	\$1223	\$1315	\$1808	\$2607
18"	18 <sup>7</sup> / <sub>8</sub> "	36"	22"	Package 36	Package 36	<b>RLF18361D</b> _	\$1445	\$1550	\$2015	\$2814
18"	18 <sup>7</sup> / <sub>8</sub> "	42"	22"	Package 42	Package 42	<b>RLF18421D</b> _	\$1647	\$1775	\$2420	\$3219
23 <sup>1</sup> / <sub>8</sub> "	24"	30"	22"	Package 30	Package 30	<b>RLF24301D</b> _	\$1567	\$1683	\$2386	\$3185
23 <sup>1</sup> / <sub>8</sub> "	24"	36"	22"	Package 36	Package 36	<b>RLF24361D</b> _	\$1839	\$1973	\$2646	\$3445

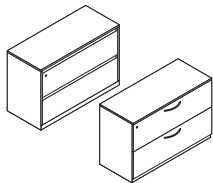

**Two 12"H Drawers**

18"	18 <sup>7</sup> / <sub>8</sub> "	30"	28"	Package 3	Package 30	<b>RLF18302</b> _	\$1355	\$1448	\$2042	\$2841
18"	18 <sup>7</sup> / <sub>8</sub> "	36"	28"	Package 4	Package 30	<b>RLF18362</b> _	\$1586	\$1693	\$2253	\$3052
18"	18 <sup>7</sup> / <sub>8</sub> "	42"	28"	Package 4	Package 30	<b>RLF18422</b> _	\$1792	\$1922	\$2657	\$3456
23 <sup>1</sup> / <sub>8</sub> "	24"	30"	28"	Package 3	Package 30	<b>RLF24302</b> _	\$1664	\$1779	\$2619	\$3418
23 <sup>1</sup> / <sub>8</sub> "	24"	36"	28"	Package 4	Package 30	<b>RLF24362</b> _	\$1997	\$2132	\$2880	\$3679



**For Canadian Pricing**  
Multiply U.S. Price by the Canadian price factor.  
► See page 1 for details.

# Low Storage-to-Beam Tether Bracket

Low Storage-to-Beam  
Tether Bracket



Standard Includes		Required to Specify
<ul style="list-style-type: none"> <li>▶ Need help? Product details, page 164</li> </ul>	<ul style="list-style-type: none"> <li>• Pair of tether brackets: black</li> <li>• Attachment hardware</li> </ul>	Style number

## Specification Information

Style Number	U.S. Price
UFSTB	\$24

Universal Storage



**For Canadian Pricing**  
Multiply U.S. Price by the  
Canadian price factor.  
▶ See page 1 for details.

# Basic Cushions Enhanced

For Universal One-High, 1.5-High, and Two Drawer Lateral Files

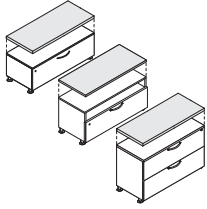

*Tip: Basic cushion enhanced is field-installed and supplies to attach are included.*

*Tip: Basic cushion enhanced is constructed with a thin solid base.*

*Tip: Basic cushion enhanced is available on Universal laterals with a top only.*

Standard Includes		Required to Specify	
<ul style="list-style-type: none"> <li>▶ Need help? Product details, page 162</li> </ul>	<ul style="list-style-type: none"> <li>• Enhanced cushion top: fabric price group 1</li> <li>• Attachment supplies: hook and loop fastener</li> </ul>	<ul style="list-style-type: none"> <li>1 Style number</li> <li>2 Fabric color number for cushion top</li> <li>3 Options, if selected (see below)</li> </ul>	<ul style="list-style-type: none"> <li>▶ See <i>Surface Materials</i>, page 360.</li> </ul>
Options		U.S. Price	Required to Specify
<b>Surface Materials</b>	<b>Upholstery</b>		
	<ul style="list-style-type: none"> <li>• Fabric price group 1</li> <li>• Fabric price group 2</li> <li>• Fabric price group 3</li> <li>• Fabric price group 4</li> <li>• Fabric price group 5</li> <li>• Fabric price group 6</li> <li>• Fabric price group 7</li> <li>• Fabric price group 8</li> <li>• Fabric price group 9</li> <li>• Fabric price group 10</li> <li>• Customer's Own Material (COM)</li> </ul>	<ul style="list-style-type: none"> <li>No cost</li> <li>+\$ 12</li> <li>+\$ 59</li> <li>+\$ 73</li> <li>+\$ 92</li> <li>+\$129</li> <li>+\$154</li> <li>+\$223</li> <li>+\$286</li> <li>+\$348</li> <li>+\$ 23</li> </ul>	<ul style="list-style-type: none"> <li>Specify fabric color number.</li> <li>Specify fabric color number.</li> <li>Specify fabric color number.</li> <li>Specify fabric color number.</li> <li>Specify fabric color number.</li> <li>Specify fabric color number.</li> <li>Specify fabric color number.</li> <li>Specify fabric color number.</li> <li>Specify fabric color number.</li> <li>Specify fabric color number.</li> <li>▶ See <i>Surface Materials Reference Manual</i>.</li> </ul>
<b>Support Brace</b>	<b>For 30"W and 36"W steel Universal laterals with an open configuration</b>		
	<ul style="list-style-type: none"> <li>• Brace (30"W and 36"W)</li> </ul>	<ul style="list-style-type: none"> <li>+\$ 77</li> </ul>	<ul style="list-style-type: none"> <li>Specify <i>with brace</i>.</li> </ul>
<b>Related Products</b>	<ul style="list-style-type: none"> <li>• Universal one-high, 1.5-high, and two drawer laterals</li> </ul>		<ul style="list-style-type: none"> <li>▶ Page 310</li> </ul>

Specification Information				
Dimensions			Style Number	U.S. Base Price
D	W	H		
18"	30"	1"	<b>RCHE1830</b>	\$374
18"	36"	1"	<b>RCHE1836</b>	\$397
18"	42"	1"	<b>RCHE1842</b>	\$420
23 1/8"	30"	1"	<b>RCHE2430</b>	\$427
23 1/8"	36"	1"	<b>RCHE2436</b>	\$443
.	.	.	.	.



## For Canadian Pricing

Multiply U.S. Price by the Canadian price factor.

▶ See page 1 for details.

# Cushion Tops

For Universal One-High, 1.5-High, and Two Drawer Lateral Files

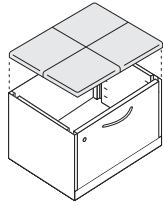

Tip: Seam pattern is determined by upholstery selected.

Tip: Your specification is not complete until you add a suffix to the style number to define the front style of the lateral, (for example, RPDC1830\_\_ becomes RPDC1830F for cushion top for flush steel front, or RPDC1830FF for cushion top for flush steel front with Fire Code Seating).

Standard Includes	Required to Specify
-------------------	---------------------

- |  |   |
|--|---|
| <ul style="list-style-type: none"> <li>▶ Need help? Product details, page 164</li> <li>• Cushion top: fabric</li> <li>• Attachment hardware</li> </ul> | <ol style="list-style-type: none"> <li>1 Style number with appropriate front style suffix in the space provided                             <ul style="list-style-type: none"> <li><b>F</b> Flush steel front</li> <li><b>P</b> Proud steel/wood front</li> </ul> </li> <li>2 Fabric color number</li> <li>3 Options, if selected (see below)                             <ul style="list-style-type: none"> <li>▶ See <i>Surface Materials</i>, page 360.</li> </ul> </li> </ol> |
|--|---|

Surface Materials	Options	U.S. Price	Required to Specify
-------------------	---------	------------	---------------------

<b>Surface Materials</b>	<b>Upholstery</b>		
	• Fabric price group 1	No cost	Specify fabric color number.
	• Fabric price group 2	+\$ 12	Specify fabric color number.
	• Fabric price group 3	+\$ 59	Specify fabric color number.
	• Fabric price group 4	+\$ 73	Specify fabric color number.
	• Fabric price group 5	+\$ 92	Specify fabric color number.
	• Fabric price group 6	+\$ 129	Specify fabric color number.
	• Fabric price group 7	+\$ 154	Specify fabric color number.
	• Fabric price group 8	+\$ 223	Specify fabric color number.
	• Fabric price group 9	+\$ 286	Specify fabric color number.
	• Fabric price group 10	+\$ 348	Specify fabric color number.
	• Leather price group	+\$ 894	Specify leather color number.
	• Select Surfaces leather price group 1	+\$ 894	▶ See <i>Surface Materials Reference Manual</i> .
• Elmosoft leather price group	+\$1030	Specify Elmosoft leather color number.	
• Select Surfaces leather price group 2	+\$1030	▶ See <i>Surface Materials Reference Manual</i> .	
• Vinyl	+\$ 12	Specify vinyl color number.	
• Customer's Own Material (COM) or Customer's Own Leather (COL)	+\$ 23	▶ See <i>Surface Materials Reference Manual</i> .	

<b>Related Products</b>	• Universal One-High, 1.5-High, and Two Drawer lateral files	▶ Page 310
-------------------------	--	------------

### Specification Information

Dimensions		W	H	Style Number	U.S. Base Prices	
D	Front				Flush Steel Front	Proud Steel/Wood Front
18"	18 <sup>7</sup> / <sub>8</sub> "	30"	1 <sup>1</sup> / <sub>2</sub> "	<b>RPDC1830__</b>	\$ 950	\$ 950
18"	18 <sup>7</sup> / <sub>8</sub> "	36"	1 <sup>1</sup> / <sub>2</sub> "	<b>RPDC1836__</b>	\$ 968	\$ 968
18"	18 <sup>7</sup> / <sub>8</sub> "	42"	1 <sup>1</sup> / <sub>2</sub> "	<b>RPDC1842__</b>	\$ 985	\$ 985
23 <sup>1</sup> / <sub>8</sub> "	24"	30"	1 <sup>1</sup> / <sub>2</sub> "	<b>RPDC2430__</b>	\$1008	\$1008
23 <sup>1</sup> / <sub>8</sub> "	24"	36"	1 <sup>1</sup> / <sub>2</sub> "	<b>RPDC2436__</b>	\$1026	\$1026

**For Canadian Pricing**  
 Multiply U.S. Price by the Canadian price factor.  
 ▶ See page 1 for details.

# Universal Open Side Towers

with Flush Steel, Proud Steel, Proud Laminate, or Proud Wood Fronts

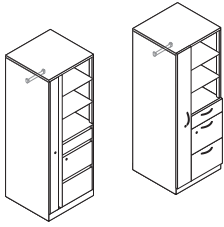

► Need help?  
Product details,  
page 166

## Standard Includes

- Tower: paint price group 1
- 1"H top: paint to match tower
- Door and drawer fronts on units with proud laminate fronts: laminate price group 1
- Door and drawer fronts on units with proud wood fronts: wood group 1 veneer
- Lock, keyed random: 9201 Polished Chrome
- Base (see below under Required Selections)
- Pulls: metal
- Integral pulls on units with flush steel fronts
- Drawer body: black only
- Adjustable shelves on 52"H and 65½"H: paint to match tower
- Brackets for adjustable shelves: black
- Post to support adjustable shelf: paint to match tower
- One box drawer divider and one pencil tray: black only
- Coat rod: black
- Four adjustable leveling glides
- Ganging hardware
- Counterweight package, if selected

## Required to Specify

- 1 Style number with appropriate front style suffix in the space provided
  - F** Flush steel front
  - P** Proud steel front
  - L** Proud laminate front
  - W** Proud wood front
- 2 Paint color number for tower
- 3 Laminate color number for door and drawer fronts, if proud laminate front selected
- 4 Wood color number for door and drawer fronts, if proud wood front selected
- 5 Base (see below under Required Selections)
- 6 Pull (see below under Required Selections)
- 7 Metal color number for pulls, if proud steel, proud laminate, or proud wood front selected
- 8 Options, if selected (see below)
  - See *Surface Materials*, page 360.

	Required Selections	U.S. Price	Required to Specify
<b>Bases</b>	<ul style="list-style-type: none"> <li>• Universal 3" base</li> <li>• FrameOne foot base</li> <li>• c:scape glide base</li> </ul>	<ul style="list-style-type: none"> <li>No cost</li> <li>+\$286</li> <li>+\$286</li> </ul>	<ul style="list-style-type: none"> <li>Specify with <i>Universal 3" base</i>, painted to match tower.</li> <li>Specify with <i>FrameOne foot base</i>, painted to match tower.</li> <li>Specify with <i>c:scape glide base</i>, 4799 Platinum Metallic only.</li> </ul>

## Pulls

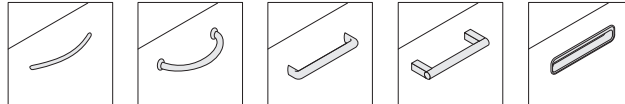

Contemporary Handle Jazz Bar c:scape

	Options	U.S. Price	Required to Specify
<b>Surface Materials</b>	<ul style="list-style-type: none"> <li>• Paint price group 1</li> <li>• Paint price group 2</li> <li>• Paint price group 3</li> </ul>	<ul style="list-style-type: none"> <li>No cost</li> <li>+\$111</li> <li>+\$192</li> </ul>	<ul style="list-style-type: none"> <li>Specify paint color number.</li> <li>Specify paint color number.</li> <li>Specify paint color number.</li> </ul>
	<ul style="list-style-type: none"> <li>• Laminate price group 1 on proud laminate fronts</li> <li>• Laminate price group 2 on proud laminate fronts</li> <li>• Laminate price group 3 on proud laminate fronts</li> <li>• Open Line laminate on proud laminate fronts</li> </ul>	<ul style="list-style-type: none"> <li>Prices at right</li> <li>See information at left</li> <li>See information at left</li> <li>+\$102 plus cost of laminate</li> </ul>	<ul style="list-style-type: none"> <li>Specify laminate color number.</li> <li>Specify laminate color number.</li> <li>Specify laminate color number.</li> <li>► See <i>Surface Materials Reference Manual</i>.</li> </ul>
	<ul style="list-style-type: none"> <li>• Wood group 2 on proud wood fronts</li> <li>• Wood group 3 on proud wood fronts</li> <li>• Customiz stain on proud wood fronts</li> </ul>	<ul style="list-style-type: none"> <li>See information at left</li> <li>See information at left</li> <li>No cost</li> </ul>	<ul style="list-style-type: none"> <li>Specify wood color number.</li> <li>Specify wood color number.</li> <li>Specify with <i>Customiz stain</i>.</li> <li>► See <i>Surface Materials Reference Manual</i>.</li> </ul>

► Options, continued on next page

**For wood and laminate group 2 and 3 pricing, please refer to the electronic catalog or SmartTools.**



## For Canadian Pricing

Multiply U.S. Price by the Canadian price factor.

► See page 1 for details.

► Options, continued from previous page

	Options	U.S. Price	Required to Specify
<b>Tops for Flush Steel Front, Proud Steel Front, Proud Laminate Front, and Proud Wood Front</b>	<b>Laminate top</b>		
	• Square edge laminate price group 1 top	+\$205	Specify with <i>laminate top</i> and indicate laminate color number for top and plastic color number for edges.
	• Square edge laminate price group 2 top	See information at left	Specify with <i>laminate top</i> and indicate laminate color number for top and plastic color number for edges.
	• Square edge laminate price group 3 top	See information at left	Specify with <i>laminate top</i> and indicate laminate color number for top and plastic color number for edges.
	• Open Line laminate on laminate top	+\$102 plus cost of laminate	► See <i>Surface Materials Reference Manual</i> .
<b>Wood veneer top</b>	• Wood group 1	+\$619	Specify with <i>wood veneer top</i> and indicate wood color number.
	• Wood group 2	See information at left	Specify with <i>wood veneer top</i> and indicate wood color number.
	• Wood group 3	See information at left	Specify with <i>wood veneer top</i> and indicate wood color number.
	• Customiz stain on wood veneer top on units with flush steel or proud steel fronts	No cost	Specify with <i>Customiz stain</i> . ► See <i>Surface Materials Reference Manual</i> .
<b>Pulls</b>	<b>Proud steel, laminate, or wood fronts</b>		
	• Contemporary	No cost	Specify with <i>contemporary pull</i> .
	• Handle	No cost	Specify with <i>handle pull</i> .
	• Jazz	+\$ 28 per pull	Specify with <i>jazz pull</i> .
	• Bar	+\$ 43 per pull	Specify with <i>bar pull</i> .
	<b>Proud steel fronts only</b>		
	• c:scape	+\$ 48 per pull	Specify with <i>c:scape pull</i> .
<b>Counterweights</b>	• Tower package 1	+\$161	Specify with <i>counterweight</i> .
	• Tower package 2	+\$198	Specify with <i>counterweight</i> .
<b>Lock and Keying</b>	<b>Lock</b>		
	• Ember Chrome	No cost	Specify with <i>9250 Ember Chrome lock</i> .
	<b>Keying</b>		
	• Factory- and field-installed keying		► Page 375
<b>Related Products</b>	• Counterweights		► Page 332
	• Steel storage accessories		► Page 332
	• Field-installed tops		► See <i>Storage Specification Guide</i> .
	• Adjustable shelves		► See <i>Storage Specification Guide</i> .
	• Bookends		► See <i>Storage Specification Guide</i> .

► Specification Information, on next page

Tip: Laminate and wood veneer tops are 3/16" taller than other tops and will add 3/16" to overall case height.

For wood group 2 and 3 pricing, please refer to the electronic catalog or SmartTools.

Tip: Counterweight packages are required to ensure product stability and are ordered as an option or separately. Product specification pages indicate the correct counterweight package for each style number and any exceptions where counterweights are not required.

► See Counterweight Requirements for Storage Products, page 111.

Tip: Height dimension listed is for units with 1" top. Overall height will vary if another top is selected.

Tip: Your specification is not complete until you add a suffix to the style number to define the front style (for example, RQS24244LA\_\_ becomes RQS24244LAF for flush steel front).



**For Canadian Pricing**

Multiply U.S. Price by the Canadian price factor.

► See page 1 for details.

Universal Open Side Towers with Flush Steel, Proud Steel, Proud Laminate, or Proud Wood Fronts, continued

► Options, on previous page

**Specification Information**

Dimensions		Style Number	U.S. Base Prices				Counterweights			
D	W H		Flush Steel Front	Proud Steel Front	Proud Lam Front	Proud Wood Front	Steel Fronts Universal 3" Base	FrameOne Foot and c:scape Glide Bases	Lam/Wood Fronts Universal 3" Base	FrameOne Foot and c:scape Glide Bases
Flush Steel Front	Proud Steel/Lam/Wood Front		Suffix F	Suffix P	Suffix L	Suffix W				

**Tower with Door Hinged on Left**

**One 6"H Drawer and Two 12"H Drawers**

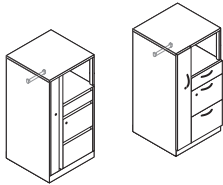

18"	18 <sup>7</sup> / <sub>8</sub> "	24" 47 <sup>1</sup> / <sub>2</sub> "	<b>RQS182448LA</b> __	\$3063	\$3560	\$4046	\$4251	Tower package 1	Tower package 1	Tower package 2	Tower package 2
23 <sup>1</sup> / <sub>8</sub> "	24"	24" 47 <sup>1</sup> / <sub>2</sub> "	<b>RQS242448LA</b> __	\$3394	\$3891	\$4377	\$4582	Not required	Tower package 1	Not required	Tower package 1

**One Adjustable Shelf, One 6"H Drawer, and Two 12"H Drawers**

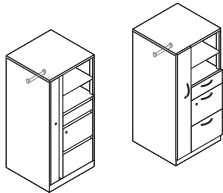

18"	18 <sup>7</sup> / <sub>8</sub> "	24" 52"	<b>RQS182444LA</b> __	\$3166	\$3663	\$4149	\$4354	Tower package 1	Tower package 1	Tower package 1	Tower package 1
23 <sup>1</sup> / <sub>8</sub> "	24"	24" 52"	<b>RQS242444LA</b> __	\$3523	\$4020	\$4506	\$4711	Not required	Not required	Not required	Not required

**Two Adjustable Shelves, One 6"H Drawer, and Two 12"H Drawers**

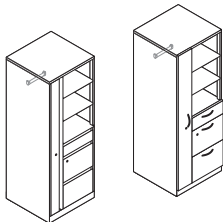

18"	18 <sup>7</sup> / <sub>8</sub> "	24" 65 <sup>1</sup> / <sub>2</sub> "	<b>RQS18245LC</b> __	\$3736	\$4233	\$4719	\$4924	Tower package 1	Tower package 1	Tower package 1	Tower package 1
23 <sup>1</sup> / <sub>8</sub> "	24"	24" 65 <sup>1</sup> / <sub>2</sub> "	<b>RQS24245LC</b> __	\$4153	\$4650	\$5136	\$5341	Not required	Not required	Not required	Not required

► Specification Information, continued on next page



**For Canadian Pricing**

Multiply U.S. Price by the Canadian price factor.

► See page 1 for details.

► Specification Information, continued from previous page

Specification Information											
Dimensions		Style Number	U.S. Base Prices				Counterweights				
D	W H		Flush Steel Front	Proud Steel Front	Proud Lam Front	Proud Wood Front	Steel Fronts Universal 3" Base	FrameOne Foot and c:scape Glide Bases	Lam/Wood Fronts Universal 3" Base	FrameOne Foot and c:scape Glide Bases	
Flush Steel Front	Proud Steel/Lam/Wood Front		Suffix F	Suffix P	Suffix L	Suffix W					

**Tower with Door Hinged on Right**

**One 6"H Drawer and Two 12"H Drawers**

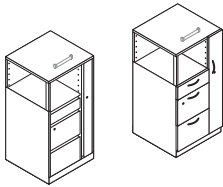

18"	18 <sup>7</sup> / <sub>8</sub> "	24" 47 <sup>1</sup> / <sub>2</sub> "	<b>RQS182448RA__</b>	\$3063	\$3560	\$4046	\$4251	Tower package 1	Tower package 1	Tower package 2	Tower package 2
23 <sup>1</sup> / <sub>8</sub> "	24"	24" 47 <sup>1</sup> / <sub>2</sub> "	<b>RQS242448RA__</b>	\$3394	\$3891	\$4377	\$4582	Not required	Tower package 1	Not required	Tower package 1

**One Adjustable Shelf, One 6"H Drawer, and Two 12"H Drawers**

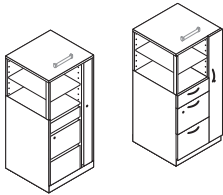

18"	18 <sup>7</sup> / <sub>8</sub> "	24" 52"	<b>RQS18244RA__</b>	\$3166	\$3663	\$4149	\$4354	Tower package 1	Tower package 1	Tower package 1	Tower package 1
23 <sup>1</sup> / <sub>8</sub> "	24"	24" 52"	<b>RQS24244RA__</b>	\$3523	\$4020	\$4506	\$4711	Not required	Not required	Not required	Not required

**Two Adjustable Shelves, One 6"H Drawer, and Two 12"H Drawers**

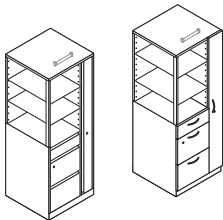

18"	18 <sup>7</sup> / <sub>8</sub> "	24" 65 <sup>1</sup> / <sub>2</sub> "	<b>RQS18245RC__</b>	\$3736	\$4233	\$4719	\$4924	Tower package 1	Tower package 1	Tower package 1	Tower package 1
23 <sup>1</sup> / <sub>2</sub> "	24"	24" 65 <sup>1</sup> / <sub>2</sub> "	<b>RQS24245RC__</b>	\$4153	\$4650	\$5136	\$5341	Not required	Not required	Not required	Not required



**For Canadian Pricing**

Multiply U.S. Price by the Canadian price factor.

► See page 1 for details.

# Universal Dual Door Towers

with Flush Steel, Proud Steel, Proud Laminate, or Proud Wood Fronts

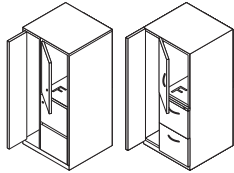

► Need help?  
Product details,  
page 166

## Standard Includes

- Tower: paint price group 1
- 1"H top: paint to match tower
- Door and drawer fronts on units with proud laminate fronts: laminate price group 1
- Door and drawer fronts on units with proud wood fronts: wood group 1 veneer
- Lock, keyed random: 9201 Polished Chrome
- Base (see below under required selections)
- Pulls: metal
- Integral pulls on units with flush steel fronts
- Drawer body: black only
- Adjustable shelves on 52"H and 65½"H: paint to match tower
- Brackets for adjustable shelves: black
- Post to support adjustable shelf: paint to match tower
- One box drawer divider and one pencil tray: black only
- Coat rod: black
- Four adjustable leveling glides
- Ganging hardware
- Counterweight package, if selected

## Required to Specify

- 1 Style number with appropriate front style suffix in the space provided
  - F** Flush steel front
  - P** Proud steel front
  - L** Proud laminate front
  - W** Proud wood front
- 2 Paint color number for tower
- 3 Laminate color number for door and drawer fronts, if proud laminate front selected
- 4 Wood color number for door and drawer fronts, if proud wood front selected
- 5 Base (see below under required selections)
- 6 Pull (see below under required selections)
- 7 Metal color number for pulls, if proud steel, proud laminate, or proud wood front selected
- 8 Options, if selected (see below)
  - See *Surface Materials*, page 360.

	Required Selections	U.S. Price	Required to Specify
<b>Bases</b>	• Universal 3" base	No cost	Specify <i>with Universal 3" base</i> , painted to match tower.
	• FrameOne foot base	+\$286	Specify <i>with FrameOne foot base</i> , painted to match tower.
	• c:scape glide base	+\$286	Specify <i>with c:scape glide base</i> , 4799 Platinum Metallic only.

## Pulls

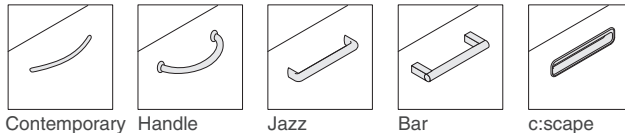

Contemporary Handle Jazz Bar c:scape

	Options	U.S. Price	Required to Specify
<b>Surface Materials</b>	• Paint price group 1	No cost	Specify paint color number.
	• Paint price group 2	+\$111	Specify paint color number.
	• Paint price group 3	+\$192	Specify paint color number.
	• Laminate price group 1 on proud laminate drawer front	Prices at right	Specify laminate color number.
	• Laminate price group 2 on proud laminate drawer front	See information at left	Specify laminate color number.
	• Laminate price group 3 on proud laminate drawer front	See information at left	Specify laminate color number.
	• Open Line laminate	+\$102 plus cost of laminate	► See <i>Surface Materials Reference Manual</i> .
	• Wood group 2 on proud wood fronts	See information at left	Specify wood color number.
	• Wood group 3 on proud wood fronts	See information at left	Specify wood color number.
	• Customiz stain on proud wood fronts	No cost	Specify <i>with Customiz stain</i> . ► See <i>Surface Materials Reference Manual</i> .

► Options, continued on next page

**For wood and laminate group 2 and 3 pricing, please refer to the electronic catalog or SmartTools.**

*Tip: Laminate and wood veneer tops are 3/16" taller than other tops and will add 3/16" to overall case height.*



## For Canadian Pricing

Multiply U.S. Price by the Canadian price factor.

► See page 1 for details.

► Options, continued from previous page

	Options	U.S. Price	Required to Specify
<b>Tops for Flush Steel Front, Proud Steel Front, Proud Laminate Front, and Proud Wood Front</b>	<b>Laminate top</b>		
	• Square edge laminate price group 1 top	+\$205	Specify with <i>laminate top</i> and indicate laminate color number for top and plastic color number for edges.
	• Square edge laminate price group 2 top	See information at left	Specify with <i>laminate top</i> and indicate laminate color number for top and plastic color number for edges.
	• Square edge laminate price group 3 top	See information at left	Specify with <i>laminate top</i> and indicate laminate color number for top and plastic color number for edges.
	• Open Line laminate on laminate top	+\$102 plus cost of laminate	► See <i>Surface Materials Reference Manual</i> .
	<b>Wood veneer top</b>		
	• Wood group 1	+\$619	Specify with <i>wood veneer top</i> and indicate wood color number.
	• Wood group 2	See information at left	Specify with <i>wood veneer top</i> and indicate wood color number.
	• Wood group 3	See information at left	Specify with <i>wood veneer top</i> and indicate wood color number.
	• Customiz stain on wood veneer top on units with flush steel or proud steel fronts	No cost	Specify with <i>Customiz stain</i> . ► See <i>Surface Materials Reference Manual</i> .
<b>Pulls</b>	<b>Proud steel, laminate, or wood fronts</b>		
	• Contemporary	No cost	Specify with <i>contemporary pull</i> .
	• Handle	No cost	Specify with <i>handle pull</i> .
	• Jazz	+\$ 28 per pull	Specify with <i>jazz pull</i> .
	• Bar	+\$ 43 per pull	Specify with <i>bar pull</i> .
	<b>Proud steel fronts only</b>		
	• c:scape	+\$ 48 per pull	Specify with <i>c:scape pull</i> .
<b>Counterweights</b>	• Tower Package 1	+\$161	Specify with <i>counterweight</i> .
	• Tower Package 2	+\$198	Specify with <i>counterweight</i> .
<b>Lock and Keying</b>	<b>Lock</b>		
	• Ember Chrome	No cost	Specify with <i>9250 Ember Chrome lock</i> .
	<b>Keying</b>		
	• Factory- and field-installed keying		► Page 375
<b>Related Products</b>	• Counterweights		► Page 332
	• Steel storage accessories		► Page 332
	• Field-installed tops		► See <i>Storage Specification Guide</i> .
	• Adjustable shelves		► See <i>Storage Specification Guide</i> .

► Specification Information, on next page

**For wood and laminate group 2 and 3 pricing, please refer to the electronic catalog or SmartTools.**

*Tip: If wood veneer top option is selected, wood veneer top color will default to match wood front.*

*Tip: Height dimension listed is for units with 1" top. Overall height will vary if another top is selected.*

*Tip: Counterweight packages are required to ensure product stability and are ordered as an option or separately. Product specification pages indicate the correct counterweight package for each style number and any exceptions where counterweights are not required.*

► See *Counterweight Requirements for Storage Products*, page 111.

*Tip: Your specification is not complete until you add a suffix to the style number to define the front style (for example, RDD182448LA becomes RDD182448LAF for flush steel front).*

 **For Canadian Pricing**  
Multiply U.S. Price by the Canadian price factor.  
► See page 1 for details.

Universal Dual Door Towers with Flush Steel, Proud Steel, Proud Laminate, or Proud Wood Fronts, continued

► Options, on previous page

**Specification Information**

Dimensions		Style Number	U.S. Base Prices				Counterweights			
D	W H		Flush Steel Front	Proud Steel Front	Proud Lam Front	Proud Wood Front	Steel Fronts Universal 3" Base	FrameOne Foot and c:scape Glide Bases	Lam/Wood Fronts Universal 3" Base	FrameOne Foot and c:scape Glide Bases
Flush Steel Front	Proud Steel/Lam/Wood Front		Suffix F	Suffix P	Suffix L	Suffix W				

**Tower with Doors Hinged on Left**

**One Fixed Shelf and Two 12"H Drawers**

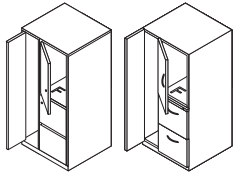

18"	18 <sup>7</sup> / <sub>8</sub> "	24" 47 <sup>1</sup> / <sub>2</sub> "	<b>RDD182448LA</b>	\$2700	\$3135	\$3536	\$3741	Tower package 1	Tower package 1	Tower package 2	Tower package 2
23 <sup>1</sup> / <sub>8</sub> "	24"	24" 47 <sup>1</sup> / <sub>2</sub> "	<b>RDD242448LA</b>	\$3253	\$3410	\$3826	\$4031	Not required	Tower package 1	Not required	Tower package 1

**One Fixed Shelf, Two 6"H Drawers, and One 12"H Drawer**

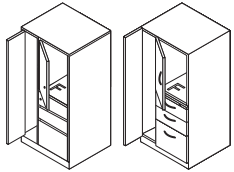

18"	18 <sup>7</sup> / <sub>8</sub> "	24" 47 <sup>1</sup> / <sub>2</sub> "	<b>RDD182448LB</b>	\$2940	\$3387	\$3797	\$4002	Tower package 1	Tower package 1	Tower package 2	Tower package 2
23 <sup>1</sup> / <sub>8</sub> "	24"	24" 47 <sup>1</sup> / <sub>2</sub> "	<b>RDD242448LB</b>	\$3482	\$3652	\$4094	\$4299	Not required	Tower package 1	Not required	Tower package 1

**One Fixed Shelf, One Adjustable Shelf, and Two 12"H Drawers**

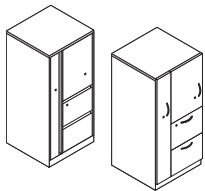

18"	18 <sup>7</sup> / <sub>8</sub> "	24" 52"	<b>RDD18244LA</b>	\$2985	\$3391	\$3785	\$3990	Tower package 1	Tower package 1	Tower package 1	Tower package 1
23 <sup>1</sup> / <sub>8</sub> "	24"	24" 52"	<b>RDD24244LA</b>	\$3515	\$3704	\$4048	\$4253	Not required	Not required	Not required	Not required

► Specification Information, continued on next page



**For Canadian Pricing**

Multiply U.S. Price by the Canadian price factor.

► See page 1 for details.

► Specification Information, continued from previous page

Specification Information											
Dimensions		Style Number	U.S. Base Prices				Counterweights				
D	W H		Flush Steel Front	Proud Steel Front	Proud Lam Front	Proud Wood Front	Steel Fronts Universal 3" Base	FrameOne Foot and c:scape Glide Bases	Lam/Wood Fronts Universal 3" Base	FrameOne Foot and c:scape Glide Bases	
Flush Steel Front	Proud Steel/Lam/Wood Front		Suffix F	Suffix P	Suffix L	Suffix W					

**Tower with Doors Hinged on Left, continued**

**One Fixed Shelf, One Adjustable Shelf, Two 6"H Drawers, and One 12"H Drawer**

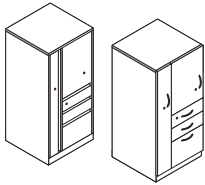

18"	18 <sup>7</sup> / <sub>8</sub> "	24" 52"	<b>RDD18244LB__</b>	\$3181	\$3493	\$3982	\$4187	Tower package 1	Tower package 1	Tower package 1	Tower package 1
23 <sup>1</sup> / <sub>8</sub> "	24"	24" 52"	<b>RDD24244LB__</b>	\$3710	\$3793	\$4293	\$4498	Not required	Not required	Not required	Not required

**One Fixed Shelf, Two Adjustable Shelves, and Two 12"H Drawers**

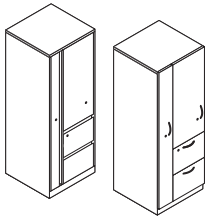

18"	18 <sup>7</sup> / <sub>8</sub> "	24" 65 <sup>1</sup> / <sub>2</sub> "	<b>RDD18245LC__</b>	\$3349	\$3816	\$4204	\$4409	Tower package 1	Tower package 1	Tower package 1	Tower package 1
23 <sup>1</sup> / <sub>8</sub> "	24"	24" 65 <sup>1</sup> / <sub>2</sub> "	<b>RDD24245LC__</b>	\$3710	\$3842	\$4580	\$4785	Not required	Not required	Not required	Not required

**One Fixed Shelf, Two Adjustable Shelves, Two 6"H Drawers, and One 12"H Drawer**

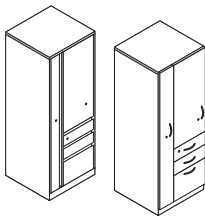

18"	18 <sup>7</sup> / <sub>8</sub> "	24" 65 <sup>1</sup> / <sub>2</sub> "	<b>RDD18245LD__</b>	\$3544	\$3988	\$4400	\$4605	Tower package 1	Tower package 1	Tower package 1	Tower package 1
23 <sup>1</sup> / <sub>8</sub> "	24"	24" 65 <sup>1</sup> / <sub>2</sub> "	<b>RDD24245LD__</b>	\$3906	\$4036	\$4781	\$4986	Not required	Not required	Not required	Not required

► Specification Information, continued on next page



**For Canadian Pricing**

Multiply U.S. Price by the Canadian price factor.

► See page 1 for details.

Universal Dual Door Towers with Flush Steel, Proud Steel, Proud Laminate, or Proud Wood Fronts, continued

► Specification Information, continued from previous page

Specification Information											
Dimensions		Style Number	U.S. Base Prices				Counterweights				
D	W H		Flush Steel Front	Proud Steel Front	Proud Lam Front	Proud Wood Front	Steel Fronts Universal 3" Base	FrameOne Foot and c:scape Glide Bases	Lam/Wood Fronts Universal 3" Base	FrameOne Foot and c:scape Glide Bases	
Flush Steel Front	Proud Steel/Lam/Wood Front		Suffix F	Suffix P	Suffix L	Suffix W					

**Tower with Doors Hinged on Right**

**One Fixed Shelf and Two 12"H Drawers**

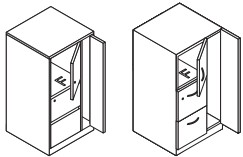

18"	18 <sup>7</sup> / <sub>8</sub> "	24"	47 <sup>1</sup> / <sub>2</sub> "	<b>RDD182448RA__</b>	\$2700	\$3135	\$3536	\$3741	Tower package 1	Tower package 1	Tower package 2	Tower package 2
23 <sup>1</sup> / <sub>8</sub> "	24"	24"	47 <sup>1</sup> / <sub>2</sub> "	<b>RDD242448RA__</b>	\$3253	\$3410	\$3826	\$4031	Not required	Tower package 1	Not required	Tower package 1

**One Fixed Shelf, Two 6"H Drawers, and One 12"H Drawer**

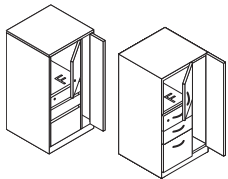

18"	18 <sup>7</sup> / <sub>8</sub> "	24"	47 <sup>1</sup> / <sub>2</sub> "	<b>RDD182448RB__</b>	\$2940	\$3387	\$3797	\$4002	Tower package 1	Tower package 1	Tower package 2	Tower package 2
23 <sup>1</sup> / <sub>8</sub> "	24"	24"	47 <sup>1</sup> / <sub>2</sub> "	<b>RDD242448RB__</b>	\$3482	\$3652	\$4094	\$4299	Not required	Tower package 1	Not required	Tower package 1

**One Fixed Shelf, One Adjustable Shelf, and Two 12"H Drawers**

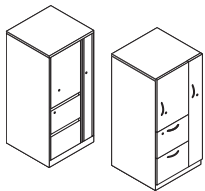

18"	18 <sup>7</sup> / <sub>8</sub> "	24"	52"	<b>RDD18244RA__</b>	\$2985	\$3391	\$3785	\$3990	Tower package 1	Tower package 1	Tower package 1	Tower package 1
23 <sup>1</sup> / <sub>8</sub> "	24"	24"	52"	<b>RDD24244RA__</b>	\$3515	\$3704	\$4048	\$4253	Not required	Not required	Not required	Not required

► Specification Information, continued on next page



**For Canadian Pricing**

Multiply U.S. Price by the Canadian price factor.

► See page 1 for details.

► Specification Information, continued from previous page

Specification Information											
Dimensions			Style Number	U.S. Base Prices				Counterweights			
D	W	H		Flush Steel Front	Proud Steel Front	Proud Lam Front	Proud Wood Front	Steel Fronts Universal 3" Base	FrameOne Foot and c:scape Glide Bases	Lam/Wood Fronts Universal 3" Base	FrameOne Foot and c:scape Glide Bases
Flush Steel Front	Proud Steel/Lam/Wood Front			Suffix F	Suffix P	Suffix L	Suffix W				

**Tower with Doors Hinged on Right, continued**

**One Fixed Shelf, One Adjustable Shelf, Two 6"H Drawers, and One 12"H Drawer**

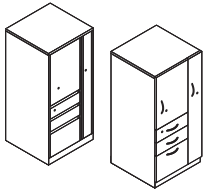

18"	18 7/8"	24"	52"	<b>RDD18244RB__</b>	\$3181	\$3493	\$3982	\$4187	Tower package 1	Tower package 1	Tower package 1	Tower package 1
23 1/8"	24"	24"	52"	<b>RDD24244RB__</b>	\$3710	\$3793	\$4293	\$4498	Not required	Not required	Not required	Not required

**One Fixed Shelf, Two Adjustable Shelves, and Two 12"H Drawers**

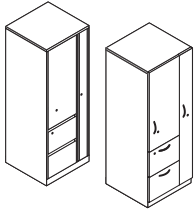

18"	18 7/8"	24"	65 1/2"	<b>RDD18245RC__</b>	\$3349	\$3816	\$4204	\$4409	Tower package 1	Tower package 1	Tower package 1	Tower package 1
23 1/8"	24"	24"	65 1/2"	<b>RDD24245RC__</b>	\$3710	\$3842	\$4580	\$4785	Not required	Not required	Not required	Not required

**One Fixed Shelf, Two Adjustable Shelves, Two 6"H Drawers, and One 12"H Drawer**

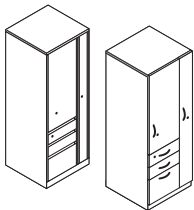

18"	18 7/8"	24"	65 1/2"	<b>RDD18245RD__</b>	\$3544	\$3988	\$4400	\$4605	Tower package 1	Tower package 1	Tower package 1	Tower package 1
23 1/8"	24"	24"	65 1/2"	<b>RDD24245RD__</b>	\$3906	\$4036	\$4781	\$4986	Not required	Not required	Not required	Not required



**For Canadian Pricing**

Multiply U.S. Price by the Canadian price factor.

► See page 1 for details.

# Universal Lateral Files

with Flush Steel, Proud Steel, Proud Laminate, or Proud Wood Fronts

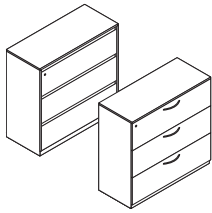

► Need help?  
Product details,  
page 170

## Standard Includes

- Lateral file: paint price group 1
- 1"H top on units with flush steel or proud steel fronts: paint to match file
- Drawer fronts on units with proud laminate fronts: laminate price group 1
- Drawer fronts on units with proud wood fronts: wood group 1 veneer
- Integral pulls on units with flush steel front
- Pulls: metal
- Lift-up door with fixed shelf on 65½"H units with flush steel or proud steel front: paint
- Lift-up door with fixed shelf on 65½"H units with proud laminate fronts: laminate price group 1
- Lift-up door with fixed shelf on 65½"H units with proud wood fronts: wood group 1 veneer
- Central lock, keyed random: 9201 Polished Chrome
- One label holder per drawer: clear plastic
- Drawer body: black only
- Drawer suspensions: black only
- One hanging folder bar per drawer on 18"D units
- Two rails per drawer on 24"D units
- One hanging folder bar and three dividers on roll-out shelf, if selected
- Four adjustable leveling glides
- Ganging hardware
- Counterweight package, if selected

## Required to Specify

- 1 Style number with appropriate front style suffix in the space provided
  - F** Flush steel front
  - P** Proud steel front
  - L** Proud laminate front
  - W** Proud wood front
- 2 Paint color number for file
- 3 Laminate color number for drawer fronts, if proud laminate front selected
- 4 Wood color number for drawer fronts, if proud wood front selected
- 5 Pull (see below under required selections)
- 6 Metal color number for pulls, if proud steel, proud laminate, or proud wood front selected
- 7 Options, if selected (see below)
  - See *Surface Materials*, page 360.

## Required Selections

### Pulls

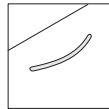

Contemporary

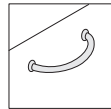

Handle

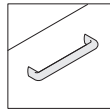

Jazz

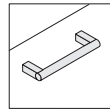

Bar

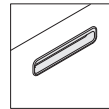

c:scape

	Options	U.S. Price	Required to Specify
<b>Surface Materials</b>	<ul style="list-style-type: none"> <li>• Paint price group 1</li> <li>• Paint price group 2</li> <li>• Paint price group 3</li> </ul>	No cost +\$111 +\$192	Specify paint color number. Specify paint color number. Specify paint color number.
	<ul style="list-style-type: none"> <li>• Laminate price group 1 on proud laminate fronts</li> <li>• Laminate price group 2 on proud laminate fronts</li> <li>• Laminate price group 3 on proud laminate fronts</li> <li>• Open Line laminate on proud laminate fronts</li> </ul>	Prices at right See information at left See information at left +\$102 plus cost of laminate	Specify laminate color number. Specify laminate color number. Specify laminate color number. ► See <i>Surface Materials Reference Manual</i> .
	<ul style="list-style-type: none"> <li>• Wood group 2 on proud wood fronts</li> <li>• Wood group 3 on proud wood fronts</li> <li>• Customiz stain on proud wood fronts</li> </ul>	See information at left See information at left No cost	Specify wood color number. Specify wood color number. Specify with <i>Customiz stain</i> . ► See <i>Surface Materials Reference Manual</i> .

► Options, continued on next page



### For Canadian Pricing

Multiply U.S. Price by the Canadian price factor.

► See page 1 for details.

► Options, continued from previous page

Options	U.S. Price	Required to Specify	
<b>Tops for Flush Steel Front and Proud Steel Front</b>	<b>No top on 40"H or 52"H</b>		
	• For use under a worksurface or beneath a common top	-\$147	Specify with no top.
	<b>Laminate top</b>		
	• Square edge laminate price group 1 top	+\$205	Specify with laminate top and indicate laminate color number for top and plastic color number for edges.
	• Square edge laminate price group 2 top	See information at left	Specify with laminate top and indicate laminate color number for top and plastic color number for edges.
	• Square edge laminate price group 3 top	See information at left	Specify with laminate top and indicate laminate color number for top and plastic color number for edges.
	• Open Line laminate on laminate top	+\$102 plus cost of laminate	► See Surface Materials Reference Manual.
	<b>Wood veneer top</b>		
	• Wood group 1	+\$619	Specify with wood veneer top and indicate wood color number.
	• Wood group 2	See information at left	Specify with wood veneer top and indicate wood color number
	• Wood group 3	See information at left	Specify with wood veneer top and indicate wood color number.
	• Customiz stain on wood veneer top	No cost	Specify with Customiz stain. ► See Surface Materials Reference Manual
<b>Tops for Proud Laminate Front</b>	<b>No top</b>		
	• For use with a cushion top or beneath a common top	-\$414	Specify with no top.
	<b>Laminate top</b>		
	• Laminate price group 1 on laminate top	No cost	Specify laminate color number.
	• Laminate price group 2 on laminate top	See information at left	Specify laminate color number.
	• Laminate price group 3 on laminate top	See information at left	Specify laminate color number.
	• Open Line laminate on laminate top	+\$102 plus cost of laminate	► See Surface Materials Reference Manual.
	<b>Wood veneer top</b>		
	• Wood group 1	+\$352	Specify with wood veneer top and indicate wood color number.
	• Wood group 2	See information at left	Specify with wood veneer top and indicate wood color number.
	• Wood group 3	See information at left	Specify with wood veneer top and indicate wood color number.
	• Customiz stain	No cost	Specify with Customiz stain. ► See Surface Materials Reference Manual.
<b>Tops for Proud Wood Front</b>	<b>No top on 40"H or 52"H</b>		
	• For use under a worksurface or beneath a common top	-\$766	Specify with no top.
	<b>Laminate top</b>		
	• Square edge laminate price group 1 top	-\$414	Specify with laminate top and indicate laminate color number for top and plastic color number for edges.
	• Square edge laminate price group 2 top	See information at left	Specify with laminate top and indicate laminate color number for top and plastic color number for edges.
	• Square edge laminate price group 3 top	See information at left	Specify with laminate top and indicate laminate color number for top and plastic color number for edges.
	• Open Line laminate on laminate top	+\$102 plus cost of laminate	► See Surface Materials Reference Manual.

► Options, continued on next page

Tip: Laminate and wood veneer tops are 3/16" taller than other tops and will add 3/16" to overall case height.

Tip: Full-fill finish (option) is available on field-installed tops only.

► See Storage specification guide.

**For wood and laminate group 2 and 3 pricing,** please refer to the electronic catalog or SmartTools.



**For Canadian Pricing**

Multiply U.S. Price by the Canadian price factor.

► See page 1 for details.

Universal Lateral Files with Flush Steel, Proud Steel, Proud Laminate, or Proud Wood Fronts, continued

► Options, continued from previous page

**For wood and laminate group 2 and 3 pricing, please refer to the electronic catalog or SmartTools.**

	Options	U.S. Price	Required to Specify
<b>Tops for Proud Wood Front, cont.</b>	<b>Wood veneer top</b>		
	<ul style="list-style-type: none"> <li>• Wood group 2</li> <li>• Wood group 3</li> <li>• Customiz stain</li> </ul>	See information at left See information at left No cost	Specify wood color number. Specify wood color number. Specify with Customiz stain. ► See Surface Materials Reference Manual.
<b>Drawer Interiors</b>	• HF bar for use on 24"D units only	+\$ 22	Specify with HF bar.
	• Divider package	+\$ 40	Specify with divider package.
	• Rails for use on 18"D units only	+\$ 51	Specify with rails.
<b>Lift-Up Door With Roll-Out Shelf</b>	<b>65½"H flush steel front files only</b>		
	<ul style="list-style-type: none"> <li>• On 18"D files</li> <li>• On 24"D files</li> </ul>	+\$ 65 +\$ 94	Specify with roll-out shelf. Specify with roll-out shelf.
<b>Pulls</b>	<b>Proud steel, laminate, or wood fronts</b>		
	<ul style="list-style-type: none"> <li>• Contemporary</li> <li>• Handle</li> <li>• Jazz</li> <li>• Bar</li> </ul>	No cost No cost +\$ 28 per pull +\$ 43 per pull	Specify with contemporary pull. Specify with handle pull. Specify with jazz pull. Specify with bar pull.
	<b>Proud steel fronts only</b>		
	• c:scape	+\$ 48 per pull	Specify with c:scape pull.
<b>Counterweights</b>	• Package 1	+\$180	Specify with counterweight.
	• Package 2	+\$180	Specify with counterweight.
	• Package 3	+\$180	Specify with counterweight.
	• Package 4	+\$235	Specify with counterweight.
<b>Lock and Keying</b>	<b>Lock</b>		
	• Ember Chrome	No cost	Specify with 9250 Ember Chrome lock.
	<b>Individual locking drawers on 18"D file</b>		
	• With three drawers	+\$392	Specify with individual lock.
	• With four drawers	+\$588	Specify with individual lock.
	<b>Individual locking drawers on 24"D file</b>		
	• With three drawers	+\$440	Specify with individual lock.
	• With four drawers	+\$660	Specify with individual lock.
	<b>Keying</b>		
	• Factory- and field-installed keying		► Page 375
<b>Related Products</b>	• Counterweights		► Page 332
	• Steel storage accessories		► Page 332
	• Field-installed tops		► See Storage Specification Guide.
	• Bookends		► See Storage Specification Guide.

Tip: Counterweight packages are required to ensure product stability and are ordered as an option or separately. Product specification pages indicate the correct counterweight package for each style number and any exceptions where counterweights are not required. ► See Counterweight Requirements for Storage Products, page 111.

Tip: 65½"H files with individual lock option do not have a lock in the lift-up door. Lift-up door is locked by the drawer below.



**For Canadian Pricing**  
 Multiply U.S. Price by the Canadian price factor.  
 ► See page 1 for details.

Tip: Height dimension listed is for units with 1" top. Overall height will vary if another top is selected.

Tip: Your specification is not complete until you add a suffix to the style number to define the front style (for example, RLF18363 becomes RLF18363F for flush steel front).

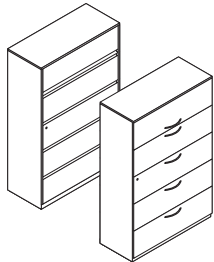
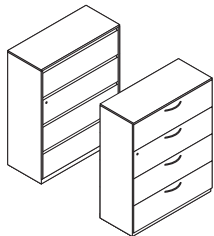
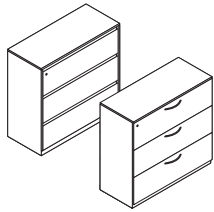

**Specification Information**

Dimensions			Counterweight Package	Style Number	U.S. Base Prices			
D	W	H			Flush Steel Front	Proud Steel/Lam/Wood Front	Proud Steel Front	Proud Lam Front
					Suffix F	Suffix P	Suffix L	Suffix W

**Three 12"H Drawers**

18"	18 <sup>7</sup> / <sub>8</sub> "	30"	40"	Package 3	<b>RLF18303</b> _	\$1828	\$2048	\$2800	\$3599
18"	18 <sup>7</sup> / <sub>8</sub> "	36"	40"	Package 3	<b>RLF18363</b> _	\$2126	\$2387	\$3089	\$3888
18"	18 <sup>7</sup> / <sub>8</sub> "	42"	40"	Package 3	<b>RLF18423</b> _	\$2409	\$2700	\$3283	\$4082
23 <sup>1</sup> / <sub>8</sub> "	24"	30"	40"	Package 2	<b>RLF24303</b> _	\$2341	\$2628	\$3323	\$4122
23 <sup>1</sup> / <sub>8</sub> "	24"	36"	40"	Package 2	<b>RLF24363</b> _	\$2675	\$3000	\$3680	\$4479

**Four 12"H Drawers**

18"	18 <sup>7</sup> / <sub>8</sub> "	30"	52"	Package 3	<b>RLF18304</b> _	\$2392	\$2683	\$3648	\$4447
18"	18 <sup>7</sup> / <sub>8</sub> "	36"	52"	Package 4	<b>RLF18364</b> _	\$2784	\$3118	\$4033	\$4832
18"	18 <sup>7</sup> / <sub>8</sub> "	42"	52"	Package 4	<b>RLF18424</b> _	\$3147	\$3530	\$4410	\$5209
23 <sup>1</sup> / <sub>8</sub> "	24"	30"	52"	Package 2	<b>RLF24304</b> _	\$3004	\$3368	\$4350	\$5149
23 <sup>1</sup> / <sub>8</sub> "	24"	36"	52"	Package 3	<b>RLF24364</b> _	\$3495	\$3924	\$4824	\$5623

**Four 12"H Drawers and One 13<sup>1</sup>/<sub>2</sub>"H Lift-Up Door with Fixed Shelf**

18"	18 <sup>7</sup> / <sub>8</sub> "	30"	65 <sup>1</sup> / <sub>2</sub> "	Package 2	<b>RLF18305</b> _	\$2871	\$3217	\$4243	\$5042
18"	18 <sup>7</sup> / <sub>8</sub> "	36"	65 <sup>1</sup> / <sub>2</sub> "	Package 2	<b>RLF18365</b> _	\$3335	\$3743	\$4711	\$5510
18"	18 <sup>7</sup> / <sub>8</sub> "	42"	65 <sup>1</sup> / <sub>2</sub> "	Package 3	<b>RLF18425</b> _	\$3771	\$4228	\$5170	\$5969
23 <sup>1</sup> / <sub>8</sub> "	24"	30"	65 <sup>1</sup> / <sub>2</sub> "	Package 1	<b>RLF24305</b> _	\$3606	\$4045	\$5091	\$5890
23 <sup>1</sup> / <sub>8</sub> "	24"	36"	65 <sup>1</sup> / <sub>2</sub> "	Package 1	<b>RLF24365</b> _	\$4189	\$4698	\$5670	\$6469

 **For Canadian Pricing**  
 Multiply U.S. Price by the Canadian price factor.  
 ▶ See page 1 for details.

# Steel Storage Accessories

## Counterweight Packages

For Use with Universal One-High and 1.5-High Lateral Files

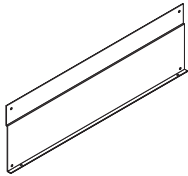

Standard Includes	Required to Specify
<ul style="list-style-type: none"> <li>▶ Need help? See <i>Storage Specification Guide</i>.</li> <li>• Counterweight: black only</li> <li>• Attachment hardware</li> </ul>	Style number

Specification Information					
Package Name	Style Number	U.S. Price	Package Name	Style Number	U.S. Price
Package 30	<b>RAACW30</b>	\$329	Package D	<b>RAACWD</b>	\$180
Package 36	<b>RAACW36</b>	\$329	Package E	<b>RAACWE</b>	\$235
Package 42	<b>RAACW42</b>	\$329	Package F	<b>RAACWF</b>	\$329

## Counterweight Packages

For Use with Universal 2H, 3H, 4H, and 5H Lateral Files, and Combination Cabinets

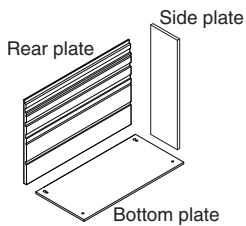

Standard Includes	Required to Specify
<ul style="list-style-type: none"> <li>▶ Need help? See <i>Storage Specification Guide</i>.</li> <li>• Counterweight: black only</li> <li>• Attachment hardware</li> </ul>	Style number

Specification Information					
Package Number	Style Number	U.S. Price	Package Number	Style Number	U.S. Price
Package 1	<b>RAACW1</b>	\$180	Package 5	<b>RAACW5</b>	\$329
Package 2	<b>RAACW2</b>	\$180	Package 6	<b>RAACW6</b>	\$329
Package 3	<b>RAACW3</b>	\$180	Package 7	<b>RAACW7</b>	\$329
Package 4	<b>RAACW4</b>	\$235	Package 8	<b>RAACW8</b>	\$329

## Counterweight Retro Kit

For Use with Universal One-High and Two Drawer Lateral Files

*Tip: Use this retrofit kit when ordering **RAACW30**, **RAACW36**, or **RAACW42**. For use on One-High or Two Drawer lateral files with feet that were manufactured prior to February 21, 2020.*

Standard Includes	Required to Specify
<ul style="list-style-type: none"> <li>• Counterweight retrofit kit</li> </ul>	Style number

Specification Information	
Style Number	U.S. Price
<b>RAACWR</b>	\$104

## Counterweight Package

For Use with Universal Towers

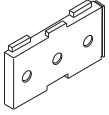

*Tip: Tower packages 1 and 2 are for 18"D and 24"D units and tower package 3 is for 30"D units.*

Standard Includes	Required to Specify
<ul style="list-style-type: none"> <li>▶ Need help? See <i>Storage Specification Guide</i>.</li> <li>• Counterweight: black only</li> <li>• Attachment hardware</li> </ul>	Style number

### Specification Information

Package Name	Style Number	U.S. Price
Tower package 1	<b>RAACT1</b>	\$161
Tower package 2	<b>RAACT2</b>	\$198
Tower package 3	<b>RAACT3</b>	\$161

## Anchor Bracket Package

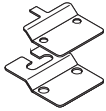

*Tip: Four anchor bracket packages are required for each cabinet.*

Standard Includes	Required to Specify
<ul style="list-style-type: none"> <li>▶ Need help? See <i>Storage Specification Guide</i>.</li> <li>• Two-piece anchor bracket and attachment hardware</li> </ul>	Style number

### Specification Information

Style Number	U.S. Price
<b>RAANBRK</b>	\$52



### For Canadian Pricing

Multiply U.S. Price by the Canadian price factor.

▶ See page 1 for details.

## Underworksurface Lateral File Fillers

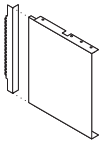

Tip: Order filler which matches nominal worksurface depth.

Tip: 24"D filler is used with 18"D storage. 30"D filler is used with 18"D or 24"D storage.

Tip: Fillers are for use with a Universal 3" base only.

Standard Includes		Required to Specify
▶ Need help? See <i>Storage Specification Guide</i> .	• Filler: paint	1 Style number 2 Paint color number 3 Options, if selected (see below) ▶ See <i>Surface Materials</i> , page 360.

Options	U.S. Price	Required to Specify
<b>Surface Materials</b>	• Paint price group 1 • Paint price group 2 • Paint price group 3	No cost +\$45 +\$74
		Specify paint color number. Specify paint color number. Specify paint color number.

Specification Information		
Depth	Style Number	U.S. Base Price
.....	.....	.....

### For Lateral Files with Flush Steel Fronts

24"	<b>ULFF24F</b>	\$81
30"	<b>ULFF30F</b>	\$81
.....	.....	.....

### For Lateral Files with Proud Fronts

24"	<b>ULFF24P</b>	\$81
30"	<b>ULFF30P</b>	\$81
.....	.....	.....

## Attachment Cable



Tip: For use with Kick underworksurface lateral files.

Standard Includes		Required to Specify
• Attachment cable • Package of 1 or 25		Style number

Specification Information	
Style Number	U.S. Price
<b>PAB12</b> (package of 1)	\$ 31
<b>PAB12M</b> (package of 25)	\$480
.....	.....



**For Canadian Pricing**  
Multiply U.S. Price by the Canadian price factor.  
▶ See page 1 for details.

---

# Understanding Lighting



<b>Statement of Line and Comparison</b>	<b>336</b>
<hr/>	
<b>Product Details</b>	
Shelf Lights	<b>340</b>
LED Shelf Lights	<b>344</b>
LED Linear Shelf Lights	<b>346</b>
<b>Application Topics</b>	
Daisy Chaining	<b>349</b>
<b>Related Products</b>	
Vertical Wire Manager	<b>350</b>

**Underwriters Laboratory (UL) and Canadian Standards Association (CSA) listed.** These lights have been designed to meet U.S. and Canadian national electrical and energy codes and most local building codes. Local electrical codes vary, so you should consult a qualified electrical contractor or engineer for proper installation of all electrical equipment.

# Statement of Line and Comparison

**Shelf lights** mount into the recessed bottom of storage shelves and bins to illuminate the worksurface. Four types of shelf lights are available to control the quality of light for specific applications. Each type is compatible with Steelcase systems furniture.

## Shelf Lights

### Storage-Mounted Lights

#### Standard Shelf Light

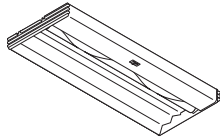

#### Mounting Options

- Universal mounting package (standard)
- Flush mount
- Competitive mounting package

Understanding  
 ▶ Page 340  
 Specifying  
 ▶ Page 352

#### Depth

9¼"

#### Width

25", 37", or 49"

#### Lamp

- T8 Fluorescent

#### Watts/Lumens/Efficacy

25"W – 17 Watts/ 1343 Lumens/ 79 Efficacy  
 37"W – 25 Watts/ 2150 Lumens/ 86 Efficacy  
 49"W – 32 Watts/ 2899 Lumens/ 90.6 Efficacy

#### Color Temperature

3500K

#### Description

The right choice for the majority of people in today's workplace who switch frequently from task to task throughout the day.

#### Optics

Faceted, white reflector  
 Contrast sleeve that can be manually rotated to vary light

#### Ballasts

- Electronic ballast
- High power factor ballast

#### Electronic Dimmer

- Not available

#### Lens Options

- None

#### Average Rated Lamp Life

- 20,000 hours

#### Warranty

- Ballast—5 years
- Fixture—12 years

**Shelf lights** offer end users added control and adjustability to place the proper amount of shelf lighting to create a holistic work setting. Ideally suited for recessed mount applications to bottom of bin or shelf.

## Shelf Lights

### Bottomline Light

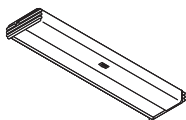

<b>Mounting</b>	<ul style="list-style-type: none"> <li>Standard includes universal spring bracket for recessed mount or screw-in for flush mount (tool free clips for New York applications).</li> </ul> <p>Understanding  ▶ Page 342  Specifying  ▶ Page 354</p>
<b>Depth</b>	4½"
<b>Width</b>	23¼", 35", or 46¾"
<b>Height</b>	1¼"
<b>Weight</b>	4.02 lb, 4.95 lb, or 6.9 lb
<b>Lamp</b>	<ul style="list-style-type: none"> <li>T5 Fluorescent</li> </ul>
<b>Watts/Lumens/Efficacy</b>	23¼"W – 14 Watts/ 1275 Lumens/ 91 Efficacy 35"W – 21 Watts/ 2000 Lumens/ 95 Efficacy 46¾"W – 28 Watts/ 2697 Lumens/ 96 Efficacy
<b>Color Temperature</b>	3500K
<b>Description</b>	Designed to be environmentally friendly providing 15% more light with an even distribution of light on the worksurface. Ideally suited for recessed mount applications to bottom of bin or shelf.
<b>Finish Options</b>	<ul style="list-style-type: none"> <li>Paint: Black (0835), Pewter (7018), or Dark Champagne (7021)</li> </ul>
<b>Optics</b>	<ul style="list-style-type: none"> <li>Mylar reflector with batwing lens</li> </ul>
<b>Ballasts</b>	<ul style="list-style-type: none"> <li>Energy saving electronic ballast</li> </ul>
<b>Electronic Dimmer</b>	<ul style="list-style-type: none"> <li>Not available</li> </ul>
<b>Average Rated Lamp Life</b>	<ul style="list-style-type: none"> <li>20,000 hrs.</li> </ul>
<b>Warranty</b>	<ul style="list-style-type: none"> <li>Ballast - 5 years</li> <li>Fixture - 10 years</li> </ul>

## Statement of Line and Comparison, continued

**Shelf lights** offer end users added control and adjustability to place the proper amount of shelf lighting to create a holistic work setting. Ideally suited for recessed mount applications to bottom of bin or shelf.

### Shelf Lights

#### Storage-Mounted Lights

#### LED Shelf Light

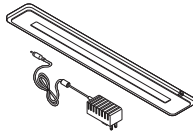

#### LED Linear Shelf Lights

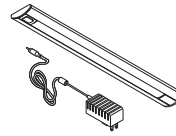

	LED Shelf Light	LED Linear Shelf Lights																																								
<b>Mounting</b>	<ul style="list-style-type: none"> <li>Standard includes magnetic mount for steel bins and shelves. Optional fastener kit for wood shelves are available.</li> </ul>	<ul style="list-style-type: none"> <li>Standard includes magnetic mount for steel bins and shelves. Each light length comes with set quantity of mounting brackets for both steel and wood applications.</li> </ul>																																								
	Understanding ▶ Page 344 Specifying ▶ Page 355	Understanding ▶ Page 346 Specifying ▶ Page 356																																								
<b>Depth</b>	2½"	2"																																								
<b>Width</b>	18"	17", 31", 44", or 58"																																								
<b>Number of LEDs</b>	<ul style="list-style-type: none"> <li>102 LEDs</li> </ul>	<table border="1"> <thead> <tr> <th>17"W</th> <th>31"W</th> <th>44"W</th> <th>58"W</th> <th></th> </tr> </thead> <tbody> <tr> <td>24</td> <td>48</td> <td>72</td> <td>96</td> <td>Standard Output LEDs</td> </tr> <tr> <td>47</td> <td>94</td> <td>141</td> <td>188</td> <td>High Output LEDs</td> </tr> </tbody> </table>	17"W	31"W	44"W	58"W		24	48	72	96	Standard Output LEDs	47	94	141	188	High Output LEDs																									
17"W	31"W	44"W	58"W																																							
24	48	72	96	Standard Output LEDs																																						
47	94	141	188	High Output LEDs																																						
<b>Watts/Lumens/Efficacy</b>	9.6 Watts/ 522 Lumens/ 54 Efficacy	<table border="1"> <thead> <tr> <th>17"W</th> <th>31"W</th> <th>44"W</th> <th>58"W</th> <th></th> </tr> </thead> <tbody> <tr> <td>7.8</td> <td>17.6</td> <td>25.9</td> <td>33.6</td> <td>Standard Output Watts</td> </tr> <tr> <td>444</td> <td>980</td> <td>1412</td> <td>1791</td> <td>Lumens</td> </tr> <tr> <td>57</td> <td>55.6</td> <td>54.5</td> <td>53.3</td> <td>Efficacy</td> </tr> <tr> <th>17"W</th> <th>31"W</th> <th>44"W</th> <th>58"W</th> <th></th> </tr> <tr> <td>10.9</td> <td>23.4</td> <td>34.3</td> <td>43.5</td> <td>High Output Watts</td> </tr> <tr> <td>744</td> <td>1590</td> <td>2290</td> <td>2807</td> <td>Lumens</td> </tr> <tr> <td>68</td> <td>68</td> <td>67</td> <td>64.5</td> <td>Efficacy</td> </tr> </tbody> </table>	17"W	31"W	44"W	58"W		7.8	17.6	25.9	33.6	Standard Output Watts	444	980	1412	1791	Lumens	57	55.6	54.5	53.3	Efficacy	17"W	31"W	44"W	58"W		10.9	23.4	34.3	43.5	High Output Watts	744	1590	2290	2807	Lumens	68	68	67	64.5	Efficacy
17"W	31"W	44"W	58"W																																							
7.8	17.6	25.9	33.6	Standard Output Watts																																						
444	980	1412	1791	Lumens																																						
57	55.6	54.5	53.3	Efficacy																																						
17"W	31"W	44"W	58"W																																							
10.9	23.4	34.3	43.5	High Output Watts																																						
744	1590	2290	2807	Lumens																																						
68	68	67	64.5	Efficacy																																						
<b>Color Rendering Index</b>	94	84																																								
<b>Color Temperature</b>	3500K	3500K																																								
<b>Description</b>	An environmentally-friendly light that consumes only 11 watts of power, contains no harmful metals (mercury), and has a useful life of over 50,000 hours. Ideally suited for recessed mount applications to bottom of bin or shelf.	With its low profile and available four widths, the LED linear light will fit in a variety of shelving and overhead storage applications. Beneficial features of this fixture include: energy efficient LEDs, continuous dimming, automatic turn off after 10 hours, and optional occupancy sensor.																																								
<b>Finish Options</b>	<ul style="list-style-type: none"> <li>Bottom surface clear anodized aluminum only. Plastic cover Arctic White (6009) or Black (6000).</li> </ul>	<ul style="list-style-type: none"> <li>4231 Arctic White body with Arctic White (6009) end caps or 0835 Black body with Black (6000) end caps.</li> </ul>																																								
<b>Optics</b>	<ul style="list-style-type: none"> <li>Polycarbonate matte film</li> </ul>	<ul style="list-style-type: none"> <li>Polycarbonate matte film</li> </ul>																																								
<b>Ballasts</b>	<ul style="list-style-type: none"> <li>Energy saving low-voltage power supply</li> </ul>	<ul style="list-style-type: none"> <li>Energy saving low-voltage power supply</li> </ul>																																								
<b>Electronic Dimmer</b>	<ul style="list-style-type: none"> <li>Standard on all lights</li> </ul>	<ul style="list-style-type: none"> <li>Standard on all lights</li> </ul>																																								
<b>Average Rated Lamp Life</b>	<ul style="list-style-type: none"> <li>50,000 hrs.</li> </ul>	<ul style="list-style-type: none"> <li>50,000 hrs.</li> </ul>																																								
<b>Warranty</b>	<ul style="list-style-type: none"> <li>Power supply - 5 years</li> <li>Fixture - 12 years</li> </ul>	<ul style="list-style-type: none"> <li>Power supply - 5 years</li> <li>Fixture - 12 years</li> </ul>																																								



Lighting

# Shelf Lights

## Standard

► Specifying, page 352

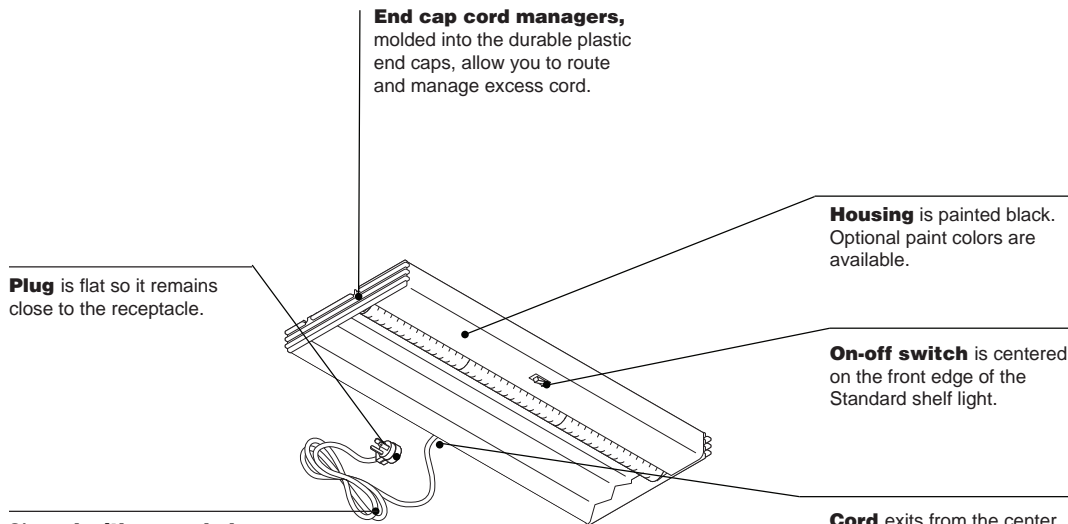

**9' cord with grounded plug** is factory installed. Length is maximum allowed by U.S. National Electrical Code. Cord with circuit breaker is available to meet the requirements of the Chicago code.

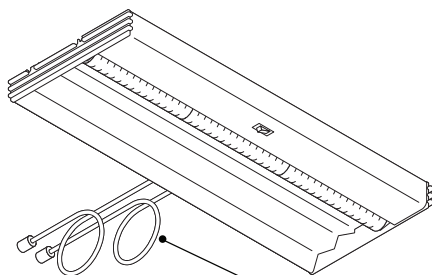

**Daisy chain cords** have modular connectors to link Standard shelf lights together.

### Product Details

**Shelf light** includes the lamp, ballast, and either a 9' cord with three-prong plug or daisy-chain cords.

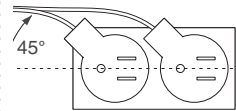

**Plug configuration** allows two Standard shelf lights to engage adjacent outlets in one receptacle.

**Energy-saving T8 lamps** have triphosphor coating for balanced color and pleasing light.

### Connections

**Shelf light** mounts recessed or flush depending on design of overhead storage bin or shelf. Installation is done in the field.

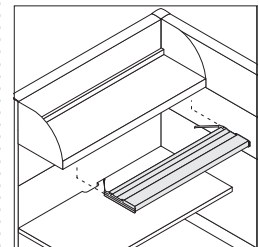

**Universal bracket** allows shelf light to be installed without tools under most metal overhead storage bins and shelves.

**Specify** LED shelf light or LED linear shelf light for use under 24" wide bins. Standard and Bottomline 24" wide lights do not fit under 24" wide bins.

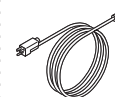

**Daisy chain starter cord** must be ordered separately when used with Standard shelf lights in a daisy chain application.

### Actual Dimensions

#### Standard

Depth	9¼" (235 mm)
Width	24⅝", 36⅝", or 48⅝" (625 mm, 930 mm, or 1235 mm)
Height	1¾" (44 mm)

Width	Lamp width	Lamp wattage	Replacement lamps
24 <sup>5</sup> / <sub>8</sub> "	24"	17 watts	F17T8-TL735
36 <sup>5</sup> / <sub>8</sub> "	36"	25 watts	F25T8-TL735
48 <sup>5</sup> / <sub>8</sub> "	48"	32 watts	F32T8-TL735

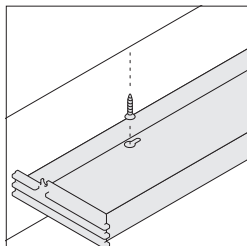

**Keyhole slots** in housing of fixture allow shelf light to be mounted beneath wood or laminate overhead storage bins and shelves using screws provided. Keyhole slots are also used to mount lights to overhead storage bins and shelves manufactured prior to August 1991.

**Standard shelf competitive mounting package** provides attachment hardware to mount Steelcase shelf lights on all major competitive furniture lines. Package includes screws and installation instructions.

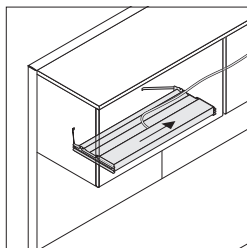

**Shelf light** can be mounted anywhere from side to side beneath overhead storage bin or shelf. The cord length is the only limitation.

**Wiring & Cabling**

**Power** drawn is approximately 1/2 amp.

**Daisy chaining** permits interconnecting up to six Standard shelf lights from a single power outlet.   
▶ Page 349

**Starter cord** powers first light in a daisy chain and allows you to convert any daisy chain light for independent operation.

**Electronic high-power-factor ballast** that is roughly 45% more efficient than a normal-power-factor ballast is available on Standard.

**Surface Materials**

**Housing**

- Black paint (standard)
- Paint colors (option)

**Reflector**

- White

**Cord**

- Black plastic only

**End cap cord manager**

- Black plastic only

**Photometric Data**

Standard								
Initial horizontal footcandles for LSM24K								
Worksurface rear								
3"	88	85	78	67	55	42	31	22
6"	93	90	82	70	57	43	31	23
9"	91	88	81	69	56	41	30	21
12"	82	80	72	62	50	38	28	20
15"	69	67	61	53	43	33	24	18
18"	56	55	49	43	36	28	21	16
21"	41	40	37	32	27	22	17	13
24"	29	28	26	23	19	16	13	10
27"	19	19	18	16	14	12	10	8
30"	13	13	12	11	10	9	7	6
CL	3"	6"	9"	12"	15"	18"	21"	
Worksurface front								

# Shelf Lights

## Bottomline

► Specifying, page 354

### Bottomline

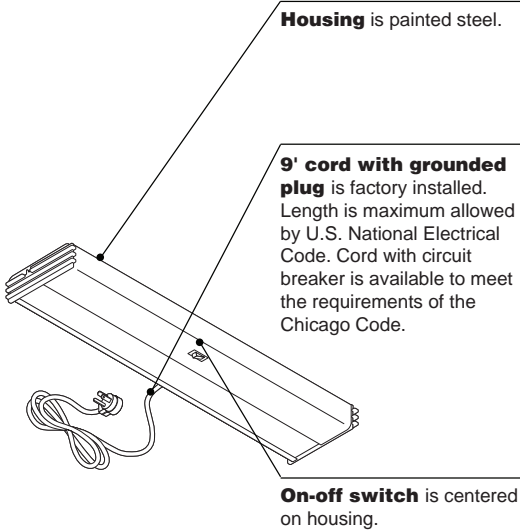

### Product Details

**Shelf light** includes the lamp, ballast, and either a 9' cord with a three-prong plug or a Chicago plug.

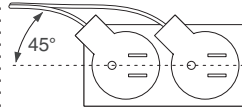

**Plug configuration** allows two task lights to engage adjacent outlets in one receptacle.

**Optics:**  
**Bottomline** includes a batwing lens with mylar reflector that provides low glare and broad distribution of light.

### Connections

**Shelf light** mounts recessed or flush depending on the design of the overhead storage bin or shelf. Standard with universal spring brackets for recessed mount or screw-in for flush mount.

**Specify** LED shelf light or LED linear shelf light for use under 24" wide bins. Standard and Bottomline 24" wide lights do not fit under 24" wide bins.

Width	Lamp width	Lamp wattage	Replacement lamps
24"	23.3"	14 watts	F14T5-835
36"	35.1"	21 watts	F21T5-835
48"	46.8"	28 watts	F28T5-835

**Lamp life of a fluorescent lamp** that turns on and off once a day will last longer than a lamp that turns on and off many times a day. Environmental effects can shorten the life of a lamp, such as: moisture or higher humidity, higher or colder than normal temperatures, excessive vibration, and power surges.

*Tip: If the light begins to flicker, or shuts down immediately, the sensor is indicating the lamp is at the end of its life and needs to be replaced.*

### Wiring & Cabling

**Power** drawn is approximately 1/2 amp.

**Daisy chaining** is only available on Bottomline shelf lights.

**Daisy chaining on Bottomline** permits interconnecting up to six shelf lights from a single power outlet.

► Page 349

**Daisy chaining on Bottomline** allows for independent operation of lights.

**Electronic ballast** is more energy efficient than T8 electronic ballasts.

### Surface Materials

#### Housing

- Paint
- 0835 Black
- 7018 Pewter
- 7021 Dark Champagne

#### Reflector

- Mylar reflector with batwing lens - flat acrylic diffuser

#### Cord

- Black plastic only

#### End caps

- Molded to match housing

### Actual Dimensions

<b>Depth</b>	4 1/2"
<b>Width</b>	23 1/4", 35", 46 3/4"
<b>Height</b>	1 1/4"
<b>Weight</b>	4.02 lb, 4.95 lb, 6.9 lb

**Photometric Data****Bottomline**Initial horizontal footcandles for L52FT  
Worksurface rear

3"	52	49	43	37	28	20	15	10
6"	77	72	63	52	39	29	20	14
9"	98	93	80	66	50	36	26	17
12"	114	107	94	77	58	42	30	20
15"	124	117	104	85	63	47	33	22
18"	119	112	99	81	63	46	32	22
21"	98	92	81	68	52	39	28	19
24"	70	68	61	51	40	30	22	16
27"	47	44	40	34	27	22	16	12
30"	29	27	25	23	18	15	12	9

CL    3"    6"    9"    12"    15"    18"    21"

Worksurface front

# LED Shelf Lights

► Specifying, page 355

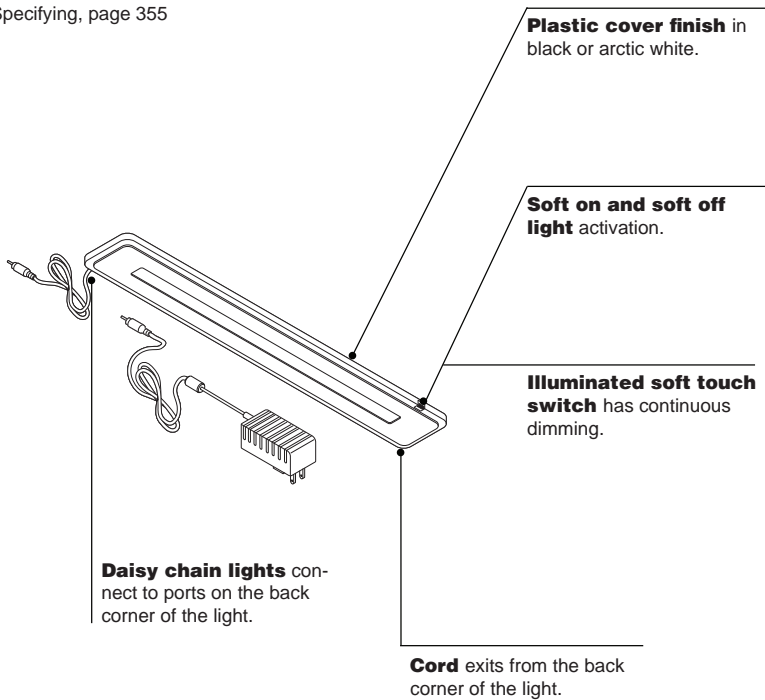

## Product Details

**Shelf light** includes the lamp and power supply with cord set. Daisy chain primary light includes lamp and larger power supply to support up to three lights. Daisy chain secondary light includes lamp and daisy chain cord set.

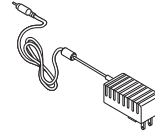

**An 18 watt power supply** is used on the LED standard light; it is 9' long with a two prong driver plug. *Tip: Energy saving mini-LEDs greatly reduce power use.*

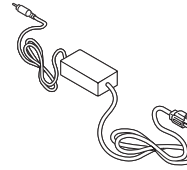

**Power supply for LED daisy chain starter light** uses an 11' 60 watt modular cord with standard two prong plug, an integrated low voltage cord, and a connector to attach to light.

## Connections

**Shelf light** mounts recessed or flush depending on design of overhead storage bin or shelf. Installation is done in the field.

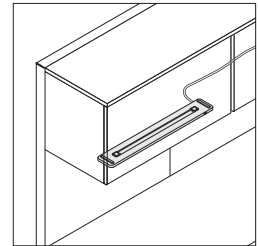
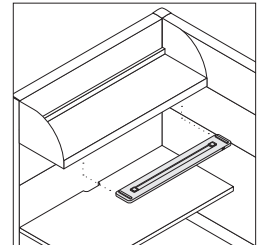

**Magnetic mounting** allows shelf light to be installed without tools under most metal overhead storage bins and shelves. This mounting allows the light to be mounted to most competitive steel bins and shelves.

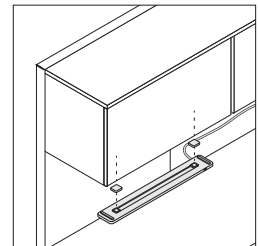

**Optional fastener kit** allows shelf light to be mounted to wood shelves.

**Specify** LED shelf light or LED linear shelf light for use under 24" wide bins. Standard and Bottomline 24" wide lights do not fit under 24" wide bins.

## Actual Dimensions

<b>Depth</b>	2 <sup>5</sup> / <sub>8</sub> "
<b>Width</b>	18 <sup>1</sup> / <sub>8</sub> "
<b>Height</b>	1/2"

- Power Supply 18 Watt Cord
  - 9' with two prong driver plug
- Power Supply 60 Watt Cord Set (11')
  - Line voltage cord: 6'
  - Low voltage cord: 5'

**Wiring & Cabling**

**Shelf light** includes the lamp and power supply with cord set. Daisy chain starter light includes lamp and larger power supply to support up to three lights. Daisy chain secondary light includes lamp and daisy chain cord set.

**Power supply for LED daisy chain starter light**

uses a 60 watt modular cord with standard two prong plug, an integrated low voltage cord, and a connector to attach to light. An 18 watt power supply is used on the LED standard light, it is 9' long with a two prong driver plug.

*Tip: Daisy chain starter light comes with a 60 watt power supply to support up to three lights. Daisy chain secondary lights do not come with a power supply, but instead come with a daisy chain cord set.*

**Surface Materials**

**Housing**

- 6000 Black
- 6009 Arctic White

**Reflector**

- Clear anodized aluminum only

**Cord**

- Black plastic only

**Photometric Data**

**LED Shelf Light**

Initial horizontal footcandles for LSL18

Worksurface rear

12"	16	22	29	36	42	47	48	46	40	34	27	20	15
9"	20	28	38	49	59	66	67	64	56	46	35	26	19
6"	24	35	48	62	76	85	87	83	72	58	44	31	22
3"	27	39	55	72	89	101	104	98	85	67	50	35	24
CL	28	41	57	76	94	107	111	104	89	70	52	36	25
3"	26	38	54	71	88	100	103	97	83	66	49	34	24
6"	23	33	50	60	73	83	85	80	69	55	41	30	20
9"	19	26	36	46	55	62	64	61	53	43	33	24	17
12"	15	20	25	32	38	42	44	41	37	30	24	18	13
18"	15"	12"	9"	6"	3"	CL	3"	6"	9"	12"	15"	18"	

Worksurface front

# LED Linear Shelf Lights

**A properly diffused light source under the linear head**

provides a softly blended light pattern that reduces eye strain.

► Specifying, page 356

**Optional occupancy sensor** turns off after 30 minutes of no activity and will turn back on upon return.

**Single touch on/off pad plus touch and hold dimming** for easy individual user control.

**Continuous dimming** from 100% to 15% with last state memory.

**Cord** exits from either end of the light.

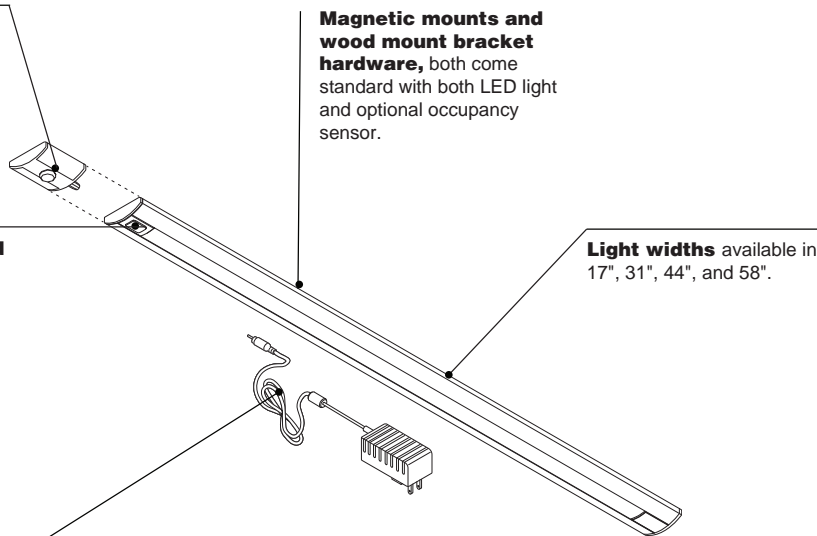

## Product Details

**LED linear stand alone and daisy chain starter lights** include the lamp, power supply, and both magnetic mounts, and wood bracket hardware with adhesive cord managers.

**LED linear daisy chain lights** include the lamp, daisy chain cords, and both magnetic mounts, and wood mount bracket hardware with adhesive cord managers.

**Optional occupancy sensor** is a separate component that connects to the light fixture and activates in 30 minutes when no movement is detected to conserve energy. It will also turn back on upon return.

**Average rated lamp life of LED linear shelf lights** is 50,000 hours.

**Color temperature LEDs** is 3500K.

**Color rendering index of LEDs** is 84.

**Automatic turn off after 10 hours** (+/- 15 mins.); standard with both models.

## Connections

**Lights** mount recessed or flush depending on design of overhead storage bin or shelf. Installation is done in the field.

**Magnet mounts** allow shelf lights to be installed without tools under most metal overhead storage bins of shelves.

**Wood mount brackets** allow shelf lights to be mounted to wood shelves.

## Actual Dimensions

	Light	Occupancy Sensor
<b>Depth</b>	2"	2"
<b>Width</b>	17", 31", 44", 58"	2 <sup>3</sup> / <sub>10</sub> "
<b>Height</b>	1/2"	7/10"

Lamp width	Number of LEDs in Standard Output/ High Output	System Wattage Standard Output/ High Output
17"	24 / 47	7.8 / 10.9
31"	48 / 94	17.6 / 23.4
44"	72 / 141	25.9 / 34.3
58"	96 / 188	33.6 / 43.5

**Wiring & Cabling**

**Light** is standard with single touch on/off and touch control dimming.

**User adjustable touch and hold dimming pad** includes continuous dimming range of 100% to 15%.

**Power supply for 17" linear stand alone only** uses a straight plug with a 9' 18 watt 24 volt wall transformer.

**Power supply for 31", 44", 58", or 17" starter light;** 60 watt compact in-line brick straight plug. The cord is 11', 6' from power supply to power outlet and 5' from power supply to fixture.

*Tip: Daisy chain starter light comes with a 60 watt power supply to support up to a limited number of lights – refer to chart for daisy chaining fixtures. Daisy chain secondary lights do not come with a power supply, but instead come with two daisy chain jumper cords, one 8" and one 30" set.*

▶ See page 348

**Surface Materials**

- Housing**
- 4321 Arctic White
  - 0835 Black

- Cord**
- Black plastic only

**Photometric Data**

17"W Standard Output Linear Shelf Light								17"W High Output Linear Shelf Light							
Worksurface rear								Measured from 18" above worksurface							
12"	11	19	28	33	28	19	11	12"	11	19	28	33	28	19	11
6"	21	20	18	17	15	13	11	6"	21	20	18	17	15	13	11
CL	31	31	29	26	23	19	15	CL	31	31	29	26	23	19	15
6"	51	50	46	42	36	29	23	6"	51	50	46	42	36	29	23
12"	82	79	73	64	53	43	32	12"	82	79	73	64	53	43	32
18"	12"	6"	CL	6"	12"	18"		18"	12"	6"	CL	6"	12"	18"	
Worksurface front								Worksurface front							
31"W Standard Output Linear Shelf Light								31"W High Output Linear Shelf Light							
Worksurface rear								Worksurface rear							
12"	28	43	55	59	55	43	28	12"	28	43	55	59	55	43	28
6"	44	73	96	104	96	73	44	6"	44	73	96	104	96	73	44
CL	53	91	121	131	121	91	53	CL	53	91	121	131	121	91	53
6"	44	73	96	104	96	73	44	6"	44	73	96	104	96	73	44
12"	28	43	55	59	55	43	28	12"	28	43	55	59	55	43	28
18"	12"	6"	CL	6"	12"	18"		18"	12"	6"	CL	6"	12"	18"	
Worksurface front								Worksurface front							
44"W Standard Output Linear Shelf Light								44"W High Output Linear Shelf Light							
Worksurface rear								Worksurface rear							
12"	48	61	69	71	69	61	48	12"	48	61	69	71	69	61	48
6"	80	104	116	119	116	104	80	6"	80	104	116	119	116	104	80
CL	99	129	144	148	144	129	99	CL	99	129	144	148	144	129	99
6"	80	104	116	119	116	104	80	6"	80	104	116	119	116	104	80
12"	48	61	69	71	69	61	48	12"	48	61	69	71	69	61	48
18"	12"	6"	CL	6"	12"	18"		18"	12"	6"	CL	6"	12"	18"	
Worksurface front								Worksurface front							
58"W Standard Output Linear Shelf Light								58"W High Output Linear Shelf Light							
Worksurface rear								Worksurface rear							
12"	63	70	74	74	74	70	63	12"	63	70	74	74	74	70	63
6"	106	117	122	123	122	117	106	6"	106	117	122	123	122	117	106
CL	131	145	150	151	150	145	131	CL	131	145	150	151	150	145	131
6"	106	117	122	123	122	117	106	6"	106	117	122	123	122	117	106
12"	63	70	74	74	74	70	63	12"	63	70	74	74	74	70	63
18"	12"	6"	CL	6"	12"	18"		18"	12"	6"	CL	6"	12"	18"	
Worksurface front								Worksurface front							

**Chart for Daisy Chaining Fixture**

Standard Output Linear Shelf Light											
Light fixture widths	Maximum number of fixtures allowed with daisy chain starter light										
17"	6	4	3	2	2	1	1	-	-	-	-
31"	-	1	-	2	-	2	1	3	1	1	-
44"	-	-	1	-	-	-	1	-	1	-	2
58"	-	-	-	-	1	-	-	-	-	1	-

High Output Linear Shelf Light				
Light fixture widths	Maximum number of fixtures allowed with daisy chain starter light			
17"	4	2	1	-
31"	-	1	-	2
44"	-	-	1	-

- A 60 watt power supply is required for daisy chaining.
- Total system wattage of all fixtures together cannot meet or exceed 60 watts, see chart.
- Cannot daisy chain standard output and high output together.
- Cannot daisy chain 58" high output fixtures.
- Occupancy sensor must be positioned between the power supply and the first starter fixture.
- Only need one sensor when daisy chaining.

*Tip: Each column is the maximum number of fixtures that can be daisy chained together.*

**Occupancy Sensor**

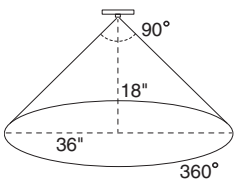

- Turns off after 30 minutes of no activity and will turn back on upon return
- 360° lens view
- 90° outward detection angle
- 30" diameter coverage if mounted 15" above worksurface
- 36" diameter coverage if mounted 18" above worksurface
- Connects to fixture with one end-to-end connector. 8" or 30" jumper cords

# Daisy Chaining

For Standard and Bottomline Lights

**Daisy chaining shelf lights** together extends power from one fixture to another within workstations to help keep receptacles clear for other uses.

**For Standard shelf lights,** starter cord is required with daisy chain cords to bring power to the first shelf light in a daisy chain so there's no need to designate where each fixture will be used within the chain.

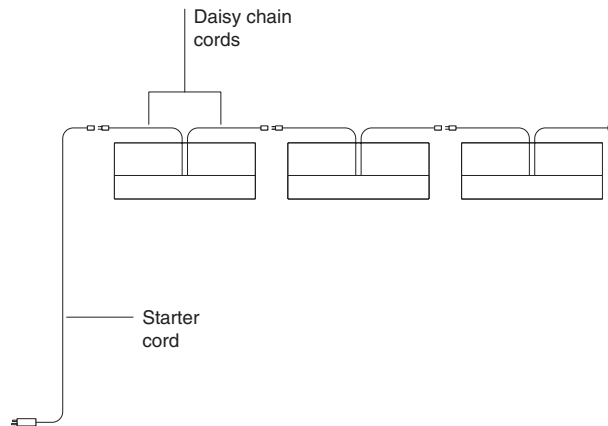

**Power will not be interrupted** in a chain even if one of the shelf lights is turned off or its lamp has burned out. That's because the path of power through the chain doesn't pass through the lamps or switches.

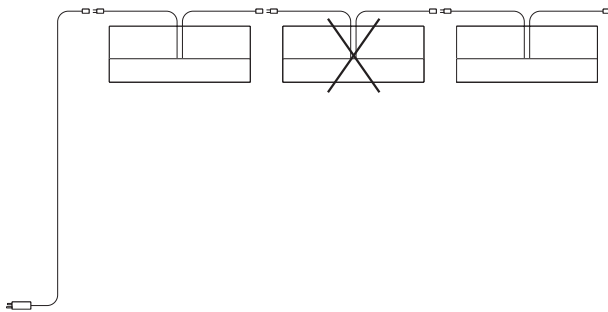

**For Bottomline lights,** starter light is required with daisy chain lights to bring power to the first light in the daisy chain.

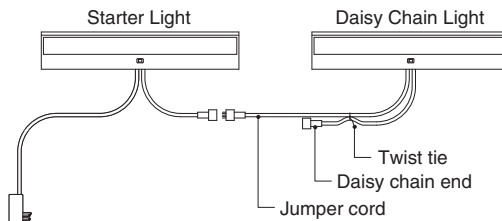

*Tip: Daisy chaining is not allowed in Chicago. Local electrical codes vary, so you should consult a qualified electrical contractor or engineer for proper installation of all electrical equipment.*

*Tip: Overhead cabinets and shelves provide a recessed area for shelf lights. They are not designed to conceal cords when daisy chaining.*

*Tip: When using upmount brackets with overhead storage and daisy chaining lights, use the open design upmount bracket for better cord management.*

# Vertical Wire Manager

## Vertical wire manager

conceals cords and cables that are routed vertically outside of the panels.

► Specifying, page 358

**Cover** conceals cords or cables.

**Hooks** fit into vertical channel at edge of panel.



## Product Details

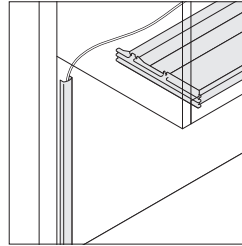

**Wire manager** is available for use between the bottom of a shelf or overhead storage bin and a worksurface. Wire manager can be cut in the field to suit specific application.

**Wire manager** can also be used below the worksurface.

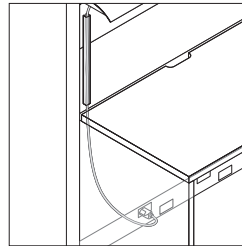

**Power cords and cables** can be routed from the wire manager and the  $\frac{1}{2}$ " gap along the back edge of the worksurface.

## Connections

**Snaps** into the slotted channel of the junction.

## Surface Materials

### Cover

- 6000 Black
- 6009 Arctic White
- 6249 Platinum Solid
- 6652 Titanium
- 6654 Sand
- 6697 Fog

## Actual Dimensions

<b>Depth</b>	1" (25 mm)
<b>Width</b>	1 $\frac{5}{8}$ " (41 mm)
<b>Height</b>	48" (1219 mm)

---

# Specifying Lighting

## Lighting

Standard Shelf Lights	352
Bottomline Shelf Lights	354
LED Shelf Lights	355
LED Linear Shelf Lights	356

## Related Products

Vertical Wire Managers	358
------------------------	-----

# Standard Shelf Lights

*Tip: Daisy chaining shelf lights together extends power from one fixture to another within workstations to help keep receptacles clear for other uses.*  
 ▶ See page 349 for more information.

*Tip: Daisy chaining is not allowed in Chicago. Local electrical codes vary, so you should consult a qualified electrical contractor or engineer for proper installation of all electrical equipment.*

*Tip: Because shelf lights are usually recessed, black is the standard paint color. Paint colors other than black have an upcharge.*

*Tip: If an optional paint color is selected for the housing, the electrical switches and end caps will remain black plastic.*

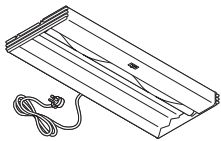

*Tip: When ordering with standard power cord or Chicago cord, daisy chaining is not possible.*

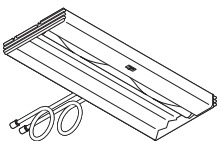

*Tip: Remember to order a daisy chain starter cord.*  
 ▶ See Related Products next page.

 **For Canadian Pricing**  
 Multiply U.S. Price by the Canadian price factor.  
 ▶ See page 1 for details.

Standard Includes		Required to Specify
▶ Need help? Product details, page 340	<ul style="list-style-type: none"> <li>Light housing with centered on-off switch: black paint</li> <li>End cap cord managers: black plastic only</li> <li>Cords:               <ul style="list-style-type: none"> <li>—Standard and Chicago (including circuit breaker), 9' cord with three-prong plug at 45° angle: black plastic only</li> <li>—Daisy chain, one 78" cord with modular connectors for daisy chaining: black plastic only</li> </ul> </li> <li>Contrast sleeve around lamp</li> <li>Faceted reflector: white only</li> <li>T8 3500K lamp</li> <li>Ballast</li> <li>Universal mounting hardware package</li> <li>Daisy chain starter cord, if selected: black plastic only (order separately)</li> </ul>	1 Style number 2 Paint color number, if other than black (see options below) 3 Options, if selected (see below) ▶ See <i>Surface Materials</i> , page 360.

Options	U.S. Price	Required to Specify
<b>Surface Materials</b> • Painted light housing other than black	+\$36	Specify paint color number for housing.
<b>Bracket Option</b> • Competitive mounting package • Flush mounting package	No cost No cost	Specify <i>with competitive mounting package</i> . Specify <i>with flush mounting package</i> and paint color number for end cap covers.

## Specification Information

Dimensions			Lamp	Style	U.S.
D	W	H	Wattage	Number	Base Price

## Electronic High-Power-Factor Ballast

### With Standard Power Cord

9¼"	25"	1¾"	17 watts	<b>LSM24K</b>	\$625
9¼"	37"	1¾"	25 watts	<b>LSM36K</b>	\$662
9¼"	49"	1¾"	32 watts	<b>LSM48K</b>	\$716

### With Chicago Cord Including Circuit Breaker

9¼"	25"	1¾"	17 watts	<b>LSM24KC</b>	\$722
9¼"	37"	1¾"	25 watts	<b>LSM36KC</b>	\$759
9¼"	49"	1¾"	32 watts	<b>LSM48KC</b>	\$813

### With Daisy Chain Cords

9¼"	25"	1¾"	17 watts	<b>LSM24KD</b>	\$680
9¼"	37"	1¾"	25 watts	<b>LSM36KD</b>	\$717
9¼"	49"	1¾"	32 watts	<b>LSM48KD</b>	\$771

▶ **Specification Information, continued on next page**

► **Specification Information, continued from previous page**

**Related Products**

Quantity in Package	Length	Style Number	U.S. Price
---------------------	--------	--------------	------------

**Daisy Chain Starter Cord**

1	78"	<b>LS1FSC</b>	\$ 86
6	78"	<b>LS6FSC</b>	\$516
:	:	:	:

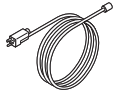

*Tip: Use with Standard shelf light with daisy chain cord only.*



**For Canadian Pricing**

Multiply U.S. Price by the Canadian price factor.

► See page 1 for details.

# Bottomline Shelf Lights

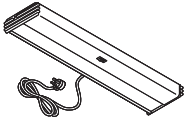

*Tip: Daisy chaining shelf lights together extends power from one fixture to another within workstations to help keep receptacles clear for other uses.*

▶ See page 349 for more information.

*Tip: Daisy chaining is not allowed in Chicago. Local electrical codes vary, so you should consult a qualified electrical contractor or engineer for proper installation of all electrical equipment.*

*Tip: When ordering with standard power cord or Chicago cord, daisy chaining is not possible.*

*Tip: When ordering the Bottomline shelf lights with daisy chain starter cord you do NOT need to order a starter cord or jumper cord.*

Standard Includes	Required to Specify
<ul style="list-style-type: none"> <li>▶ Need help? Product details, page 342</li> <li>• Steel light housing: paint</li> <li>• Mylar reflector</li> <li>• Batwing lens</li> <li>• Polycarbonate end caps: molded to match housing</li> <li>• Cords:                             <ul style="list-style-type: none"> <li>—Standard and Chicago (including circuit breaker), 9' cord with three-prong plug at 45° angle: black plastic only</li> <li>—Daisy chain, one 56" cord with modular connections for daisy chaining: black plastic only</li> </ul> </li> <li>• Energy efficient electronic ballast</li> <li>• Energy efficient 3500K T5 fluorescent light</li> <li>• Universal spring brackets for recessed mount and screw-in for flush mount</li> <li>• Tool free clips for New York application</li> </ul>	<ul style="list-style-type: none"> <li>1 Style number</li> <li>2 Paint color number for housing and end caps:                             <ul style="list-style-type: none"> <li>0835 Black</li> <li>7018 Pewter</li> <li>7021 Dark Champagne</li> </ul> </li> </ul>

## Specification Information

Dimensions			Lamp Wattage	Style Number	U.S. Price
D	W	H			
<b>With Standard Power Cord</b>					
4½"	23¼"	1¼"	14 watts	<b>L52FT</b>	\$373
4½"	35"	1¼"	21 watts	<b>L53FT</b>	\$400
4½"	46¾"	1¼"	28 watts	<b>L54FT</b>	\$431
<b>With Chicago Cord Including Circuit Breaker</b>					
4½"	23¼"	1¼"	14 watts	<b>L52FTCHI</b>	\$437
4½"	35"	1¼"	21 watts	<b>L53FTCHI</b>	\$476
4½"	46¾"	1¼"	28 watts	<b>L54FTCHI</b>	\$508
<b>With Daisy Chain Cord</b>					
4½"	23¼"	1¼"	14 watts	<b>L52FTY</b>	\$413
4½"	35"	1¼"	21 watts	<b>L53FTY</b>	\$437
4½"	46¾"	1¼"	28 watts	<b>L54FTY</b>	\$467
<b>With Daisy Chain Starter Cord</b>					
4½"	23¼"	1¼"	14 watts	<b>L52FTS</b>	\$413
4½"	35"	1¼"	21 watts	<b>L53FTS</b>	\$437
4½"	46¾"	1¼"	28 watts	<b>L54FTS</b>	\$467

## Specification Guidelines

Application	Requirement
2 lights	1 starter fixture and 1 daisy chain fixture
3 lights	1 starter fixture and 2 daisy chain fixtures
4 lights	1 starter fixture and 3 daisy chain fixtures
5 lights	1 starter fixture and 4 daisy chain fixtures
6 lights	1 starter fixture and 5 daisy chain fixtures

**Note:** Daisy chaining minimum of two fixtures; maximum of six fixtures.



### For Canadian Pricing

Multiply U.S. Price by the Canadian price factor.

▶ See page 1 for details.

Standard Includes		Required to Specify
<ul style="list-style-type: none"> <li>▶ Need help? Product details, page 344</li> </ul>	<ul style="list-style-type: none"> <li>• Aluminum extrusion with plastic cover</li> <li>• Power supply with cord</li> <li>• Soft touch switch</li> <li>• Thin profile accommodates recessed and low profile flush mounting</li> <li>• Ultra energy efficient LED light source</li> <li>• Universal magnetic mounting</li> <li>• Polycarbonate matte film diffuser</li> <li>• Continuous dimming</li> </ul>	<ul style="list-style-type: none"> <li>1 Style number</li> <li>2 Plastic color number for cover: 6000 Black, 6009 Arctic White</li> <li>3 Options, if selected (see below)</li> </ul>

Tip: Maximum number of lights that can be daisy chained is three lights.

Options	U.S. Price	Required to Specify
<b>Mounting</b> <ul style="list-style-type: none"> <li>• Fastener kit for use with wood shelf</li> </ul>	+\$9	Specify with fastener kit.

### Specification Information

Dimensions			Lamp	Style	U.S.
D	W	H	Wattage	Number	Base Price
:	:	:	:	:	:

### LED Standard Light

2 1/2"	18"	1/2"	9.6 watts	<b>LSL18</b>	\$506
:	:	:	:	:	:

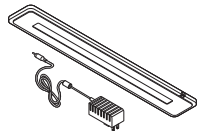

Tip: LED standard light comes with a 9' 18 watt power supply.

### LED Daisy Chain Starter Light

2 1/2"	18"	1/2"	9.6 watts	<b>LSL18YA</b>	\$545
:	:	:	:	:	:

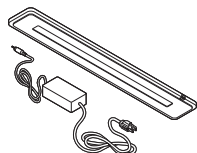

Tip: Daisy chain starter light comes with a 60 watt power supply that will support up to three lights in series (11' cord; 6' from power supply to power outlet, 5' from power supply to fixture). Does not include daisy chain jumper cords.

### LED Daisy Chain Secondary Light

2 1/2"	18"	1/2"	9.6 watts	<b>LSL18YB</b>	\$498
:	:	:	:	:	:

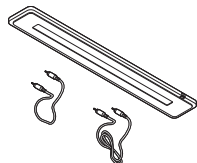

Tip: Daisy chain secondary light does not come with a power supply. Daisy chain cord package (8" and 30") comes standard with each secondary light.

# LED Linear Shelf Lights

*Tip: The power supply for the 17" stand alone only uses a straight plug with a 9' 18 watt 24 volt wall transformer. The power supply for the 31", 44", 58", or 17" starter light uses a 11' 60 watt compact in-line brick with straight plug.*

	Standard Includes	Required to Specify
<ul style="list-style-type: none"> <li>▶ Need help? Product details, page 346</li> </ul>	<ul style="list-style-type: none"> <li>• Task light and mounting bracket: 4231 Arctic White</li> <li>• Power supply with cord: black</li> <li>• Soft touch switch</li> <li>• Magnetic and wood mounting brackets</li> <li>• Continuous range dimmer</li> <li>• Automatic turn off program</li> <li>• Color temperature 3500K</li> </ul>	<ul style="list-style-type: none"> <li>1 Style number</li> <li>2 Options, if selected (see below)</li> </ul>

	Options	U.S. Price	Required to Specify
<b>Surface Materials</b>	<ul style="list-style-type: none"> <li>• Painted light housing in 0835 Black</li> </ul>	+\$ 19	Specify with 0835 Black.
<b>Occupancy Sensor</b>	<ul style="list-style-type: none"> <li>• 17"W, 31"W, 44"W, and 58"W with stand alone or daisy chain starter</li> </ul>	+\$187	Specify with occupancy sensor.
<b>High Output</b>	<ul style="list-style-type: none"> <li>• 17"W with stand alone, starter, or secondary</li> </ul>	+\$118	Specify with high output.
	<ul style="list-style-type: none"> <li>• 31"W, 44"W, and 58"W with stand alone or daisy chain starter, or secondary</li> </ul>	+\$201	Specify with high output.

Specification Information				
Dimensions	Style		U.S. Base Price	
	D	W		
2"	17"	7/10"	LLL17	\$384

## 17" Stand Alone Light

2"	17"	7/10"	LLL17	\$384
----	-----	-------	-------	-------

## 17" Daisy Chain Starter Light

2"	17"	7/10"	LLL17YA	\$447
----	-----	-------	---------	-------

## 17" Daisy Chain Secondary Light

2"	17"	7/10"	LLL17YB	\$334
----	-----	-------	---------	-------

## 31" Stand Alone or Daisy Chain Starter Light

2"	31"	7/10"	LLL31	\$621
----	-----	-------	-------	-------

▶ Specification Information, continued on next page

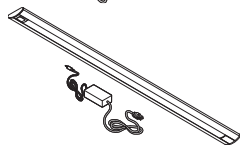
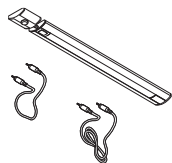
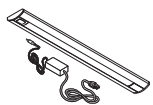
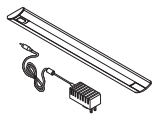

### For Canadian Pricing

Multiply U.S. Price by the Canadian price factor.

▶ See page 1 for details.

► **Specification Information, continued from previous page**

**Specification Information**

• Dimensions			• Style	• U.S.
D	W	H	Number	Base Price

**31" Daisy Chain Secondary Light**

2"	31"	7/10"	<b>LLL31YB</b>	\$514
:	:	:	:	:

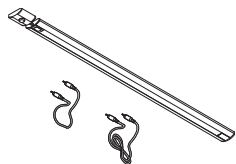

**44" Stand Alone or Daisy Chain Starter Light**

2"	44"	7/10"	<b>LLL44</b>	\$ 824
:	:	:	:	:

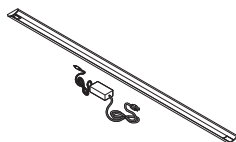

**44" Daisy Chain Secondary Light**

2"	44"	7/10"	<b>LLL44YB</b>	\$ 690
:	:	:	:	:



**58" Stand Alone or Daisy Chain Starter Light**

2"	58"	7/10"	<b>LLL58</b>	\$1055
:	:	:	:	:

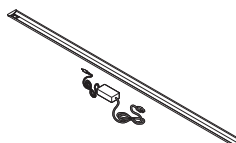

**58" Daisy Chain Secondary Light**

2"	58"	7/10"	<b>LLL58YB</b>	\$ 744
:	:	:	:	:

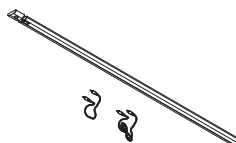

Lighting

 **For Canadian Pricing**  
 Multiply U.S. Price by the Canadian price factor.  
 ► See page 1 for details.

# Vertical Wire Managers

## Vertical Wire Manager



Tip: Wire manager can be cut in the field to the specific length needed.

Standard Includes	Required to Specify
-------------------	---------------------

<ul style="list-style-type: none"> <li>▶ Need help? Product details, page 350</li> <li>• Vertical wire manager: plastic</li> </ul>	<ul style="list-style-type: none"> <li>1 Style number</li> <li>2 Plastic color number:                             <ul style="list-style-type: none"> <li>6000 Black</li> <li>6009 Arctic White</li> <li>6249 Platinum Solid</li> <li>6652 Titanium</li> <li>6654 Sand</li> <li>6697 Fog</li> </ul> </li> </ul>
--	---

Specification Information		
Height	Style Number	U.S. Price

48"	TS7PVWM	\$46
:	:	:
:	:	:

## Vertical Wire Managers

With Wing Edges



Tip: Wire manager can be cut in the field to the specific length needed.

Tip: Wings along length of wire manager are captured by edge of skin or vertical trim to hold wire manager in place.

Standard Includes	Required to Specify
-------------------	---------------------

<ul style="list-style-type: none"> <li>▶ Need help? Product details, page 350</li> <li>• Vertical wire manager: plastic</li> </ul>	<ul style="list-style-type: none"> <li>1 Style number</li> <li>2 Plastic color number:                             <ul style="list-style-type: none"> <li>6000 Black</li> <li>6659 Light Grey</li> </ul> </li> </ul>
--	--

Specification Information		
Height	Style Number	U.S. Price

20"	TSAEVWMZ20	\$26
:	:	:
:	:	:



### For Canadian Pricing

Multiply U.S. Price by the Canadian price factor.

▶ See page 1 for details.

---

# Surface Materials

<b>Surface Materials</b>	<b>360</b>
<b>Specification Guidelines for Directional Fabrics</b>	<b>365</b>
<b>Paint Color Availability Matrix</b>	<b>366</b>
<b>Recommended Worksurface Edge Finishes</b>	<b>368</b>
<b>Directional Laminate Grain Directions</b>	<b>371</b>
<b>Wood Veneer Grain Directions</b>	<b>372</b>

# Surface Materials

**This listing** includes all the surface material choices that are available for the products in this specification guide.

## Resources

For more information about surface materials, refer to the following resources:

**Additional surface materials specification tools** are available to assist you in the specification process—the Surface Materials Binders.

**The global surface materials palette** is a core collection of finishes that is available across multiple geographies (Americas/ EMEA – Europe, Middle East, and Africa/APAC – Asia Pacific) and on global product lines, where applicable. For a list of finishes included in the offering, see the Surface Materials Reference Manual. Additional details, like product approvals by geography and finish number conversions, can also be found in the Surface Materials Reference Manual or see [steelcase.com/surface-materials](http://steelcase.com/surface-materials).

**Surface Materials Binders** include:

- Surface Materials Reference Manual
- A complete set of swatch cards for hard surfaces, vertical surface fabrics, and seating upholstery

## Paint

*Tip: All products may not be available in all colors listed below.*

► See page 366 for an overview of the paint colors available on each component.

## Steelcase Surfaces

### Price Group 1

#### Smooth Paint

4238 Mocha  
4239 Clay  
4240 Chalk  
4242 Milk

#### Textured Paint

7207 Black  
7225 Sand  
7237 Slate **E**  
7238 Fieldstone  
7239 Midnight  
7241 Arctic White  
7243 Seagull  
7250 Sterling Dark Solid  
7278 Dark Bronze  
7360 Merle

### Price Group 2

#### Smooth Metallic Paint

4743 Mineral Metallic  
4750 Champagne Metallic  
4798 Sterling Metallic  
4799 Platinum Metallic  
4803 Near Black Metallic

#### Textured Metallic Paint

7245 Carbon Metallic  
7246 Midnight Metallic

### Price Group 3

#### Accent Paint

1ATG Rose Quartz  
4AV3 Blue Jay  
4AV4 Baltic  
4AX1 Citrine/Citron  
4AY2 Chili  
4AZ5 Marlin  
4CL1 Dark Olivine  
4CL2 Ice Blue  
4CL3 Aura  
4CL4 Sea Glass  
4CL5 Light Matcha  
4CL6 Terra  
4CL7 Sandstone  
4CL8 Smokey Plum  
4CZ5 Honey  
4CZ6 Lagoon  
4CZ8 Light Peacock

#### Coatings

1ATT Cast Shadow

## Lux Coatings

4B20 Obsidian  
4B22 Matte Brass  
4B23 Burnished Bronze  
4B24 Night Bronze  
4B25 Matte Copper  
4B26 Smoked Mica  
4B29 Cast Iron

Applies to:

- 2½" round grommet

### Price Group 1

#### Smooth Paint

7241 Arctic White  
7278 Dark Bronze

#### Textured Paint

7360 Merle

### Price Group 2

#### Smooth Paint

0835 Black  
4700 Warm White

#### Smooth Metallic Paint

4799 Platinum Metallic

## Custom Surfaces

### Price Group 3

#### PerfectMatch

PerfectMatch is a service that allows you to create your own paint color. Refer to the *Surface Materials Reference Manual* for more information about this program.

*Tip: Not all Price Group 3 paints are available on adjustable-height work surface bases.*

## Laminate

### Steelcase Surfaces

Applies to:

- Duo Storage boxes

#### Solid Laminate

2722 Cream **E**  
2730 Arctic White  
2746 Black  
2759 Warm White  
2811 Mist **E**  
2883 Seagull  
2884 Milk  
2885 Dune  
2HMG Merle

#### High-Pressure Laminate

Applies to:

- Universal worksurfaces—High-Pressure Laminate
- TS Series common shelves

### Price Group 1

#### Fiber Laminate

2850 Vanadium Fiber  
2852 Tungsten Fiber  
2854 Vellum Fiber **E**  
2860 Granite Fiber  
2862 Stucco Fiber **E**

#### Micro Laminate

2920 Marl Micro  
2921 Gypsum Micro  
2922 Clay Micro

#### Patina Laminate

2870 Blonde Bronze Patina  
2873 Instant Iron Patina

#### Solid Laminate

2722 Cream **E**  
2730 Arctic White  
2746 Black  
2759 Warm White  
2811 Mist **E**  
2883 Seagull  
2884 Milk  
2885 Dune  
2HMG Merle  
2HWU Clay  
2HWV Chalk

#### Speckle Laminate

2820 Coffee Speckle **E**  
2823 Driftwood Speckle  
2824 Smoke Speckle  
2825 Vanadium Speckle

## Woodgrain Laminate

2406 Clear Cherry **E**  
2409 Clear Maple  
2410 Graphite Walnut  
2412 Natural Cherry  
2422 Medium Cherry  
2511 Winter on Maple  
2535 Virginia Walnut  
2536 Blackwood **E**  
2538 Clear Walnut  
2592 Blonde on Maple **E**  
2714 Natural Walnut **E**  
2HAK Clear Oak  
2HAN Ash Noce  
2HAT Acacia  
2HAW Ash Wenge  
2HBN Bisque Noce  
2HBW Bisque Wenge  
2HCN Clay Noce  
2HCW Clay Wenge  
2HCN Storm Noce  
2HSW Storm Wenge  
2HWA Grey Kingswood  
2HWB Planked Walnut  
2HWD Resolute Walnut  
2HWE Natural Recon  
2HWF Smoked Walnut

*Tip: Woodgrain Laminates are not available as matched sets. The grain patterns will not align. These are not recommended for fully segmented skin applications.*

*Tip: 2535 Virginia Walnut, 2536 Blackwood, and 2616 Marbled Maple are not available on doors.*

### Price Group 2

#### Textured Laminate

2TH2 Fawn Cypress  
2TH4 Saddle Oak  
2TH5 Veranda Teak  
2TH7 Walnut Heights  
2UH1 Reclaimed Aggregate  
2UH2 Reclaimed Gravel  
2UH4 Cement\*\*  
2UH6 Sheetrock

*\*\*2UH4 Cement has limited availability, determined by product sizing and/or options.*

**E** = Established

Applies to:

- Universal worksurfaces and storage tops

### Price Group 3

#### Solid Laminate

- 24H1 Satin White
- 24H2 Satin Black
- 24H3 Satin Stone
- 24H4 Satin Mocha

#### Steelcase Surfaces

Applies to:

- Universal worksurfaces—Low-Pressure Laminate
- TS Series worksurfaces

#### Low-Pressure Laminate

- 247L Black V2 LPL
- 25L1 Winter on Maple LPL
- 25L5 Virginia Walnut LPL
- 25L6 Blackwood LPL **E**
- 25L8 Clear Walnut LPL
- 267L Marbled Cherry V2 LPL **E**
- 26L1 Natural Cherry V2 LPL
- 2L09 Clear Maple LPL
- 2L30 Arctic White LPL
- 2L50 Vanadium Fiber LPL
- 2L52 Tungsten Fiber LPL
- 2L83 Seagull LPL
- 2L84 Milk LPL
- 2L85 Dune LPL
- 2LAK Clear Oak
- 2LAN Ash Noce LPL
- 2LAT Acacia LPL
- 2LAW Ash Wenge LPL
- 2LBN Bisque Noce LPL
- 2LBW Bisque Wenge LPL
- 2LCN Clay Noce LPL
- 2LCW Clay Wenge LPL
- 2LMG Merle LPL
- 2LSN Storm Noce LPL
- 2LSW Storm Wenge LPL
- 2LWA Grey Kingswood
- 2LWB Planked Walnut
- 2LWD Resolute Walnut
- 2LWF Smoked Walnut
- 2LWG Natural Recon
- 2TL2 Fawn Cypress

*Tip: Some wood veneer finishes and woodgrain laminates share the same name. Because of the difference in materials, veneers and laminates of the same name are not an exact match but do coordinate with each other.*

**E** = Established

### Custom Surfaces

#### Open Line Laminate (OLL)

This service allows you to order non-standard laminate at an additional processing fee of \$102 U.S. per unit, plus the cost of the laminate.

High-Pressure Laminate pricing does not include premium or digitally printed patterns from any suppliers. Laminate cost may also vary for basic or standard laminates from other suppliers. Please contact the OLL consultant at 616.475.2426 for pricing. The cost of the laminate will be added to your invoice as a separate line on the acknowledgement.

When processing orders for Open Line laminate on Universal worksurfaces and Universal Storage tops, specify 2900 in the laminate finish field and enter the OLL manufacturer information. Enter the required edge finish as you would a standard laminate.

#### Laminate Approval and Material Requirements

To confirm whether a particular laminate has already been tested for use on a specific Steelcase product or to determine material square foot requirements:

- Visit [www.steelcase.com](http://www.steelcase.com)

**For additional information,** refer to the *Steelcase Surface Materials Reference Manual*.

Applies to:

- Universal worksurfaces
- Universal Storage tops and fronts
- Overhead storage
- TS 200 Series tops

Steelcase carefully selects veneer and solid wood for consistent color and grain structure. Wood is a natural material and variations will occur in color, grain and texture. These variations are part of the inherent natural beauty of wood and are not considered defects.

All wood products will darken with age and exposure to ultraviolet light. This is especially apparent with cherry and maple veneer. We recommend that desk accessories be rearranged periodically to ensure even aging of wood surfaces.

When storing your wood furniture, please follow the following guidelines:

- Do not store products in trailers
- Store products in areas that simulate office temperatures (60°F to 90°F)
- Store products in areas that maintain constant, office-like humidity levels
- Keep product away from light. Cover products to make sure they are not exposed to light.

### Steelcase Surfaces

**Veneers** are matched for proper balance and consistency. Veneers are available flat cut or quarter cut, except for Oak, which is rift cut. Refer to the *Surface Materials Reference Manual* for descriptions of each cut.

**Open-pore finish** is a medium gloss finish that leaves the wood grain texture visible to the eye and distinguishable to the touch.

► See *Surface Materials Reference Manual* for a listing of available veneers for Victor2.

### Veneer

#### Wood Group 1

##### Flat-Cut Open-Pore

- 3062 FC/OP Graphite Walnut
- 3402 FC/OP Clear Cherry (Aged)
- 3412 FC/OP Natural Cherry **E**
- 3422 FC/OP Medium Cherry
- 3522 FC/OP Clear Maple
- 3592 FC/OP Blonde on Maple **E**
- 3702 FC/OP Clear Walnut
- 3712 FC/OP Natural Walnut
- 3752 FC/OP Medium Walnut **E**
- 3762 FC/OP Dark Walnut
- 3772 FC/OP Medium Mahogany on Walnut

##### Flat-Cut Open-Pore, Natural Veneer

- 3342 FC/OP Black Walnut
- 35A2 FC/OP Blanch Maple
- 37A2 FC/OP Thunder Walnut

##### Quarter-Cut Open-Pore

- 3042 QC/OP Ash **E**
- 3222 QC/OP Clear Maple
- 3292 QC/OP Blonde on Maple **E**
- 3302 QC/OP Clear Walnut
- 3312 QC/OP Natural Walnut
- 3352 QC/OP Medium Walnut **E**
- 3362 QC/OP Dark Walnut
- 3372 QC/OP Medium Mahogany on Walnut
- 3382 QC/OP Graphite Walnut

##### Quarter-Cut Open-Pore, Natural Veneer

- 32A2 QC/OP Blanch Maple
- 33A2 QC/OP Thunder Walnut
- 3392 QC/OP Black Walnut

##### Rift-Cut Open-Pore

- 3602 RC/OP Desert Oak

##### Rift-Cut Full-Fill, Natural Veneer

- 36A2 RC/OP Volcanic Oak

### Wood Group 3

#### Flat-Cut Open-Pore, Natural Veneer

- 3082 FC/OP Washed Walnut

### Wood Group 1

#### Open-Pore Planked Veneer

- 3P41 OP Planked Cherry
- 3P51 OP Planked Maple
- 3P61 OP Planked Oak
- 3P71 OP Planked Walnut
- 3VFX OP Unmarked Oak

*Tip: Known for its uniqueness, planked veneer has intentional and natural variations that include, but are not limited to: character marks, grain pattern, color, and natural color aging.*

#### Full-Fill

**Full-fill finish** is a medium-gloss finish that completely fills the grain texture, yet allows the grain pattern to be seen. The wood has a lustrous, satiny look, and it is smooth to the touch. This finish is available on the wood worksurface or field-installed top only.

### Wood Group 2

#### Flat-Cut Full-Fill

- 3064 FC/FF Graphite Walnut
- 3404 FC/FF Clear Cherry (Aged)
- 3414 FC/FF Natural Cherry **E**
- 3424 FC/FF Medium Cherry
- 3524 FC/FF Clear Maple
- 3544 FC/FF Blonde on Maple **E**
- 3704 FC/FF Clear Walnut
- 3714 FC/FF Natural Walnut
- 3754 FC/FF Medium Walnut **E**
- 3764 FC/FF Dark Walnut
- 3774 FC/FF Medium Mahogany on Walnut

#### Flat-Cut Full-Fill, Natural Veneer

- 3734 FC/FF Black Walnut

#### Quarter-Cut Full-Fill

- 3224 QC/FF Clear Maple
- 3294 QC/FF Blonde on Maple **E**
- 3304 QC/FF Clear Walnut
- 3314 QC/FF Natural Walnut
- 3354 QC/FF Medium Walnut **E**
- 3364 QC/FF Dark Walnut
- 3374 QC/FF Medium Mahogany on Walnut
- 3384 QC/FF Graphite Walnut

#### Quarter-Cut Full-Fill, Natural Veneer

- 3394 QC/FF Black Walnut

#### Rift-Cut Full-Fill

- 3604 RC/FF Desert Oak

### Wood Group 3

#### Flat-Cut Full-Fill, Natural Veneer

- 3084 FC/FF Washed Walnut

### Premium Veneers

A selection of Premium veneers in this collection are available on most Steelcase brand products. The collection will be available as close to standard leadtimes as possible. However, because adequate supplies of veneer and solids must be secured, all orders will be scheduled individually. Leadtimes will vary based on Premium veneer and Premium solids availability at the time the order is placed. The collection is available as Wood Group 3 as part of our Select Surfaces program, and supported like standard veneers to make ordering easy. Please see the Steelcase surface materials section on [village.steelcase.com](http://village.steelcase.com) for sample information and product line availability. All premium veneers are in clear-coat.

### Wood Group 3

#### Quarter-Cut Open-Pore

- 3832 QC/OP Figured Anegre

### Select Surfaces

For information on products within Select Surfaces, including accent paints and fabrics from Designtex, Gabriel, Kvadrat, and Pollack, please refer to the *Surface Materials Reference Manual* or visit [steelcase.com/surface-materials](http://steelcase.com/surface-materials) under the Select Surfaces section.

### Composite Veneer

Composite veneers are an engineered wood intended to create specific grain patterns and characteristics. They are pre-stained and finished with Steelcase's Clarity water-borne UV topcoat, which protects the environment while providing durability and clarity. Only open-pore finishes are available on composite wood. Composite veneer and matching edge bands are available on most Steelcase brand products. Composites, for use as a solid nosing substitute, are not available. Steelcase does not recommend mixing composite veneers with natural solid nosings because composite and natural wood grain and color matching are rarely compatible. Composite veneers are Select Surfaces and available as Wood Group 1 pricing.

### Wood Group 1

#### Flat-Cut Open-Pore

- 3JDX FC/OP Oak Composite
- 3JJX FC/OP Walnut Composite

#### Quarter-Cut Open-Pore

- 3F8X QC/OP European Walnut Composite
- 3GGX QC/OP Zebrano Composite
- 3HGX QC/OP Oak Composite
- 3HVX QC/OP Walnut Composite
- 3ZNX QC/OP Night Cerused Oak Composite

### Custom Surfaces

**Customiz stain** is a service that allows you to create your own stain colors and finishes on standard veneer. Customiz stain color is available on all product lines that offer wood veneer.

A \$500 stain-matching fee applies on CUSTOMIZ requests (Exception: The \$500 fee does not apply on matches to Coalesse standard finishes or for a low-gloss finish request on a standard color). The \$500 fee covers the cost of formulating the Customiz color finish and applies regardless of whether or not an order for product is placed.

In addition, an approval form must be signed to indicate customer acceptance of Customiz match. A \$1,500 initiation fee will be charged prior to first order entry. This initiation fee activates the finish for unlimited use on any Steelcase product for an 18 month time period. After the 18 month time period has lapsed, the Customiz finish may be reactivated for another 18 months for a \$1,000 fee at any point within five years after the \$1,500 initiation fee was paid. If the finish is not reactivated within five years after the \$1,500 initiation fee was paid, the finish will be culled and the customer will need to pay the \$1,500 initiation fee again. All style number related Customiz charges products are no cost as of April 2014. The matching and initiation fees are not discountable.

Customiz stain takes 10 days to formulate. Consult the *Surface Materials Reference Manual* for more information. Custom veneers are also available and must be quoted by Steelcase specials group. Customiz stain on custom veneers takes 2 to 4 weeks to formulate.

Requirements and information on ordering a Customiz stain color are found in the *Surface Materials Reference Manual*.

### Plastic

#### Steelcase Surfaces

*Tip: The following two plastics are available for existing customers only. The matching paints have moved to the *Surface Materials Reference Manual*.*

- 6651 Tungsten **E**
- 6652 Titanium **E**

**E** = Established

Applies to:

- 3 mm and 1 mm edge profile on Universal Systems Worksurfaces with High-Pressure Laminate
- 1 mm square edge profile on Universal Storage laminate tops
- Square edge laminate top on 200 Series

6000	Black	6631	Cream <b>E</b>
6009	Arctic White	6635	Dawn <b>E</b>
6034	Natural Cherry	6636	Mist
6036	Medium Cherry	6654	Sand
6037	Winter on Maple	6655	Warm White
6038	Blonde on Maple <b>E</b>	6695	Midnight
6041	Natural Walnut <b>E</b>	6697	Fog
6052	Milk	6698	Fieldstone
6053	Seagull	66WA	Grey Kingswood
6169	Stone	66WB	Planked Walnut
6170	Mocha	66WD	Resolute Walnut
61AA	Persian Salt	66WE	Natural Recon
61AB	Rose	66WF	Smoked Walnut
61AC	Indigo	66WU	Clay
61AD	Green Citrine	66WW	Chalk
61AE	Dark Olivine	6703	Ash Wenge
61AF	Cloudy	6704	Storm Wenge
6213	Acacia	6705	Bisque Wenge
6219	Clear Oak	6706	Clay Wenge
6231	Graphite Walnut	6707	Ash Noce
6237	Clear Maple	6708	Bisque Noce
6242	Virginia Walnut	6709	Clay Noce
6243	Blackwood <b>E</b>	6710	Storm Noce
6245	Clear Walnut	6T02	Fawn Cypress
6249	Platinum Solid	6T04	Saddle Oak
6271	Plywood	6T05	Veranda Teak
6527	Merle	6T07	Walnut Heights
6619	Ice <b>E</b>	6T08	Aggregate
		6T09	Gravel
		6T10	Cement
		6T12	Sheetrock

Applies to:

- 1 mm profile on Universal Systems Worksurfaces with High-Pressure Laminate

6000	Black
6009	Arctic White
6052	Milk
6053	Seagull
6249	Platinum Solid
6527	Merle
6612	Grey V2 <b>E</b>
6654	Sand
6655	Warm White
6695	Midnight
6697	Fog
6698	Fieldstone

*Tip: Light color plastic edges are susceptible to degradation due to normal wear and tear. Staining (e.g., ball point pen or clothing dyes such as blue jeans) and dirt effects are more pronounced in light colors and are not considered defects.*

**E** = Established

## Accessory Paint

### Steelcase Surfaces

Applies to:

- Cabby legs with glides
  - Adjustable-height legs with glides
  - Universal lateral files with c:scape pulls
- 4140 Arctic White Gloss  
4144 Black Gloss

## Metal

### Steelcase Surfaces

Applies to:

- Elliptical leg
- 9201 Polished Chrome

Applies to:

- 2½" round grommet
- 9201 Polished Chrome  
9211 Nickel

### Steelcase Surfaces

Applies to:

- Universal Storage pulls
- 0835 Black  
9201 Polished Chrome  
9211 Nickel  
9212 Silver

## Vertical Surface Fabric

Applies to:

- Knit screens
- B902 Soft White  
B903 Fog  
B904 Sand

Applies to:

- Fabric skins and trims
- Hutch kit tackboards

### Steelcase Surfaces

#### Price Group A

#### Sprite

5540	Khaki
5541	Snow
5543	Linen
5544	Sherbet
5545	Powder
5547	Sky

#### Price Group 1

#### Abacus **E**

P123	Portico
P124	Opus
P125	Cusp
P126	Artifact

#### Alloy

P525	Polar
P526	Skim
P527	Bubbly
P528	Tern
P529	Shore
P530	Asti
P531	Silver
P532	Oxide
P533	Element
P534	Construct
P535	Currency
P536	Iron

#### Boccie

P200	New Rice
P201	New Almond
P203	New Camel
P204	New Opal
P205	New Mist
P206	New Plum
P208	New Spearmint
P209	New Sky

#### Buzz2

5F03	Tomato
5F04	Red <b>E</b>
5F05	Burgundy
5F06	Sky <b>E</b>
5F07	Blue
5F08	Navy
5F15	Stone
5F16	Grey
5F17	Black
5G50	Dunegrass
5G51	Sable
5G55	Pumpkin
5G56	Timber
5G57	Rouge
5G59	Meadow
5G61	Cyan
5G62	Atlantic
5G63	Crocus
5G64	Alpine
5G65	Tornado

#### Charm

P505	Shell
P506	Mimosa
P507	Birch
P508	Sparkle
P510	Debut
P511	Clover
P513	Twilight

#### Lapel

P409	Cement
P410	Pebble
P411	Beech
P412	Dune
P414	Sprout
P416	Maple
P417	Slate

#### Optic

P540	Hazel
P541	Twinkle
P542	Orion
P543	Seaglass
P546	Whiskey
P547	Bath
P548	Whisper
P549	Breezy
P551	Glimmer

#### Pianista

P420	Sand
P421	Mist
P422	Rain
P423	Natural
P424	Café
P425	Denim
P426	Carbon
P427	Stone
P428	Flax
P429	Oat
P430	Wheat
P431	Maize

#### Rhythm

P555	Allegro
P556	Tempo
P557	Refrain
P558	Pitch
P559	Harmony <b>E</b>
P560	Melody
P561	Stanza
P562	Opus

#### Tinsel

P515	Sugar
P516	Lit
P517	Ego
P518	Fizz
P519	Muse
P520	Depth
P521	Bliss
P522	Grow
P523	Dolce
P524	Boost

**Price Group 2**

**Bariolage**

- G200 New Etude
- G201 New Andante **E**
- G202 New Cantata **E**
- G203 New Adagio
- G205 New Ballata

**Code**

- 5FA1 Fossil
- 5FA2 Gabbro
- 5FA3 Reed
- 5FA4 Bluff
- 5FA5 Sea Salt
- 5FA6 Cannon
- 5FA7 Tussah
- 5FA8 Mica
- 5FA9 Ecu
- 5FB1 Bamboo

**Flip: Orbit**

- 5F85 Mud Pie **E**
- 5F86 Hummus **E**
- 5F87 Petoskey
- 5F88 Pluto **E**
- 5F89 Papyrus
- 5F91 Blizzard
- 5F92 Briquette

**Flip: TexHex**

- 5F75 Mud Pie **E**
- 5F76 Hummus **E**
- 5F77 Petoskey
- 5F78 Pluto **E**
- 5F79 Papyrus
- 5F97 Blizzard
- 5F98 Briquette

**Fresco**

- G001 Sandrift
- G002 Mistiblu
- G003 Faon
- G006 Chamoline
- G007 Grapenut **E**
- G017 Flint **E**

**Intersection**

- P211 Summit
- P212 Chalk
- P213 Lace

**Latch**

- P600 Seashell
- P601 Clam
- P602 Eggshell
- P603 Zen
- P604 Cool Gray
- P605 Armor
- P606 Sentinel
- P607 Rye
- P608 Billow
- P609 Nimbus

**Stencil**

- P455 Midnight
- P456 Mulberry
- P457 Cracked Pepper
- P458 Denim
- P459 Chartreuse
- P460 Bittersweet
- P461 Mauvelous
- P462 Bermuda
- P463 Concrete
- P464 Orchid
- P465 Parchment
- P466 Silk
- P467 Sea Salt
- P468 Honeydew
- P469 Sepia

**Price Group 3**

**Billiard Multi-Use by Designtex**

- 5H11 Poppy
- 5H12 Tangelo
- 5H13 Citrine/Citron
- 5H14 Avocado
- 5H16 Indigo
- 5H17 Mallard
- 5H18 Teak
- 5H19 Cumulus
- 5H20 Pewter
- 5H21 Gunmetal
- 5H22 Ink
- 5H23 Rose Quartz
- 5H24 Sea Salt
- 5H25 Storm Cloud
- 5H26 Oliivine

**Select Surfaces**

**For information on products within Select Surfaces**, including accent paints and fabrics from Designtex, Gabriel, Kvadrat, and Pollack, please refer to the *Surface Materials Reference Manual* or visit [steelcase.com/surface-materials](http://steelcase.com/surface-materials) under the Select Surfaces section.

**Custom Surfaces**

**Price Group COM (Customer's Own Material)**

**Fabric Approval and Yardage**

To confirm whether a particular COM material has already been tested for use on a specific Steelcase product or to determine actual yardage requirements:

- Visit [www.steelcase.com](http://www.steelcase.com)

**For additional information regarding Customer's Own Material**, call 1.888.STEELCASE (1.888.783.3522) or send an e-mail to [lineone@steelcase.com](mailto:lineone@steelcase.com).

▶ See *Surface Materials Reference Manual* for a listing of available seating upholstery colors.

**Seating Upholstery**

Applies to:

- Mobile pedestal cushion top
  - Basic cushion enhanced
- \*Not available on basic cushion enhanced

**Steelcase Surfaces**

**Price Group 1**

- Buzz2
  - Era
  - Jacks **E**
  - Link
  - New Black
- Tip: New Black upholstery has color numbers in both price group 1 and price group 2.*

**Price Group 2**

- Chainmail
  - Cogent: Connect
  - Foundation\*
  - New Black
  - Nitelights
- Tip: New Black upholstery has color numbers in both price group 1 and price group 2.*

**Price Group 3**

- Billiard Multi-Use by Designtex
- Gaja
- Redeem
- Retrieve

**Price Group 5**

- Bo Peep
- Remix
- Silk

**Price Group 6**

- Brisa\*

**Price Group 7**

- Steelcut Trio\*

**Leather**

- Steelcase Leather\*

**Elmosoft Leather**

- Elmosoft Leather\*

Applies to:

- Kick tackboards

**Price Group 1**

- New Black: Bruce
- New Black: Henry

**Price Group 2**

- New Black: Jack
  - New Black: Harley
- Tip: New Black: James is not available on Kick tackboards.*

**Select Surfaces**

**For information on products within Select Surfaces**, including accent paints and fabrics from Designtex, Gabriel, Kvadrat, and Pollack, please refer to the *Surface Materials Reference Manual* or visit [steelcase.com/surface-materials](http://steelcase.com/surface-materials) under the Select Surfaces section.

**Custom Surfaces**

**Price Group COM (Customer's Own Material)**

**Fabric Approval and Yardage**

To confirm whether a particular COM material has already been tested for use on a specific Steelcase product or to determine actual yardage requirements:

- Visit [www.steelcase.com](http://www.steelcase.com)

**E** = Established

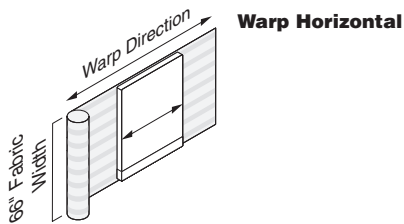

**The standard application direction** of fabric on Kick panels, skins, and Hutch kit tackboard is warp horizontal. Standard Steelcase fabrics were designed for this application direction.

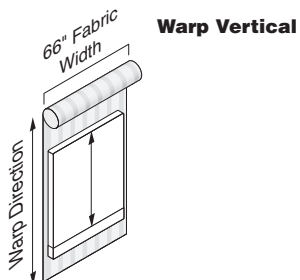

**The optional application direction** of fabrics on Kick panels, skins, and Hutch kit tackboard is warp vertical. This is most commonly used on COMs designed for warp vertical application.

**For more information about the warp direction of fabrics,** see the *Surface Materials Reference Manual*.



Paint Price Group 2 (Smooth Paint)	
<b>0835</b> Black	■
<b>4700</b> Warm White	■
Paint Price Group 3 (Coatings)	
<b>1ATT</b> Cast Shadow	•
Paint Price Group 3 (Lux Coatings)	
<b>4B20</b> Obsidian	•
<b>4B22</b> Matte Brass	•
<b>4B23</b> Burnished Bronze	•
<b>4B24</b> Night Bronze	•
<b>4B25</b> Matte Copper	•
<b>4B26</b> Smoked Mica	•
<b>4B29</b> Cast Iron	•

# Recommended Worksurface Edge Finishes

## Recommended Edge Colors—High-Pressure Laminate

### Edges

The recommended edge color will complement the laminate color you specify. Edge color is specified separately.

Laminate Color	Recommended 3 mm or 1 mm Edge Color
<b>Fiber Laminate</b>	
2850 Vanadium Fiber	6654 Sand
2852 Tungsten Fiber	6636 Mist
2854 Vellum Fiber <b>E</b>	6655 Warm White
2860 Granite Fiber	6000 Black
2862 Stucco Fiber <b>E</b>	6053 Seagull
<b>Micro Laminate</b>	
2920 Marl Micro	6053 Seagull
2921 Gypsum Micro	6654 Sand
2922 Clay Micro	6654 Sand
<b>Patina Laminate</b>	
2870 Blonde Bronze Patina	6654 Sand
2873 Instant Iron Patina	6527 Merle
<b>Solid Laminate</b>	
24H1 Satin White	6009 Arctic White
24H2 Satin Black	6000 Black
24H3 Satin Stone	6169 Stone
24H4 Satin Mocha	6170 Mocha
2722 Cream <b>E</b>	6631 Cream <b>E</b>
2730 Arctic White	6009 Arctic White
2746 Black	6000 Black
2759 Warm White	6655 Warm White
2811 Mist <b>E</b>	6636 Mist
2883 Seagull	6053 Seagull
2884 Milk	6052 Milk
2885 Dune	6654 Sand
2HAA Persian Salt	61AA Persian Salt
2HAB Rose	61AB Rose
2HAC Indigo	61AC Indigo
2HAD Green Citrine	61AD Green Citrine
2HAE Dark Olivine	61AE Dark Olivine
2HAF Cloudy	61AF Cloudy
2HMG Merle	6527 Merle
2HWU Clay	66WU Clay
2HWV Chalk	66WV Chalk
<b>Speckle Laminate</b>	
2820 Coffee Speckle <b>E</b>	6631 Cream <b>E</b>
2823 Driftwood Speckle	6631 Cream <b>E</b>
2824 Smoke Speckle	6636 Mist
2825 Vanadium Speckle	6619 Ice <b>E</b>

**E** = Established

**Recommended Edge Colors—High-Pressure Laminate, continued**

**Edges**

The recommended edge color will complement the laminate color you specify. Edge color is specified separately.

**Laminate Color**

**Recommended  
3 mm or 1 mm  
Edge Color**

**Textured Laminate**

2TH2	Fawn Cypress	6T02	Fawn Cypress
2TH4	Saddle Oak	6T04	Saddle Oak
2TH5	Veranda Teak	6T05	Veranda Teak
2TH7	Walnut Heights	6T07	Walnut Heights
2UH1	Reclaimed Aggregate	6T08	Aggregate
2UH2	Reclaimed Gravel	6T09	Gravel
2UH4	Cement	6T10	Cement
2UH6	Sheetrock	6T12	Sheetrock

**Woodgrain Laminate**

2406	Clear Cherry <b>E</b>	6234	Clear Cherry
2409	Clear Maple	6237	Clear Maple
2410	Graphite Walnut	6231	Graphite Walnut
2412	Natural Cherry	6034	Natural Cherry
2422	Medium Cherry	6036	Medium Cherry
2511	Winter on Maple	6037	Winter on Maple
2535	Virginia Walnut	6242	Virginia Walnut
2536	Blackwood <b>E</b>	6243	Blackwood <b>E</b>
2538	Clear Walnut	6245	Clear Walnut
2592	Blonde on Maple <b>E</b>	6038	Blonde on Maple <b>E</b>
2714	Natural Walnut <b>E</b>	6041	Natural Walnut <b>E</b>
2HAK	Clear Oak	6219	Clear Oak
2HAN	Ash Noce	6707	Ash Noce
2HAT	Acacia	6213	Acacia
2HAW	Ash Wenge	6703	Ash Wenge
2HBN	Bisque Noce	6708	Bisque Noce
2HBW	Bisque Wenge	6705	Bisque Wenge
2HCN	Clay Noce	6709	Clay Noce
2HCW	Clay Wenge	6706	Clay Wenge
2HSN	Storm Noce	6710	Storm Noce
2HSW	Storm Wenge	6704	Storm Wenge
2HWA	Grey Kingswood	66WA	Grey Kingswood
2HWB	Planked Walnut	66WB	Planked Walnut
2HWD	Resolute Walnut	66WD	Resolute Walnut
2HWE	Natural Recon	66WE	Natural Recon
2HWF	Smoked Walnut	66WF	Smoked Walnut

**E** = Established

## Recommended Worksurface Edge Finishes, continued

### Recommended Edge Colors—Low-Pressure Laminate

Low-Pressure Laminate Color	Recommended Edge Band
247L Black V2 LPL	6000 Black
25L1 Winter on Maple LPL	6037 Winter On Maple
25L5 Virginia Walnut LPL	6242 Virginia Walnut
25L6 Blackwood LPL <b>E</b>	6243 Blackwood
25L8 Clear Walnut LPL	6245 Clear Walnut
26L1 Natural Cherry V2 LPL	6034 Natural Cherry
2L09 Clear Maple LPL	6237 Clear Maple
2L30 Arctic White LPL	6009 Arctic White
2L50 Vanadium Fiber LPL	6654 Sand
2L52 Tungsten Fiber LPL	6697 Fog
2L83 Seagull LPL	6053 Seagull
2L84 Milk LPL	6052 Milk
2L85 Dune LPL	6654 Sand
2LAK Clear Oak	6219 Clear Oak
2LAN Ash Noce LPL	6707 Ash Noce
2LAT Acacia LPL	6213 Acacia
2LMG Merle LPL	6527 Merle
2LAW Ash Wenge LPL	6703 Ash Wenge
2LBN Bisque Noce LPL	6708 Bisque Noce
2LBW Bisque Wenge LPL	6705 Bisque Wenge
2LCN Clay Noce LPL	6709 Clay Noce
2LCW Clay Wenge LPL	6706 Clay Wenge
2LSN Storm Noce LPL	6710 Storm Noce
2LSW Storm Wenge LPL	6704 Storm Wenge
2LWA Grey Kingswood	66WA Grey Kingswood
2LWB Planked Walnut	66WB Planked Walnut
2LWD Resolute Walnut	66WD Resolute Walnut
2LWE Natural Recon	66WE Natural Recon
2LWF Smoked Walnut	66WF Smoked Walnut
2TL2 Fawn Cypress	6T02 Fawn Cypress

**E** = Established

# Directional Laminate Grain Directions

Directional Laminate  
Grain Directions

**Directional laminates** are standard with the grain directions shown.

## Universal Systems Worksurfaces—High-Pressure Laminate

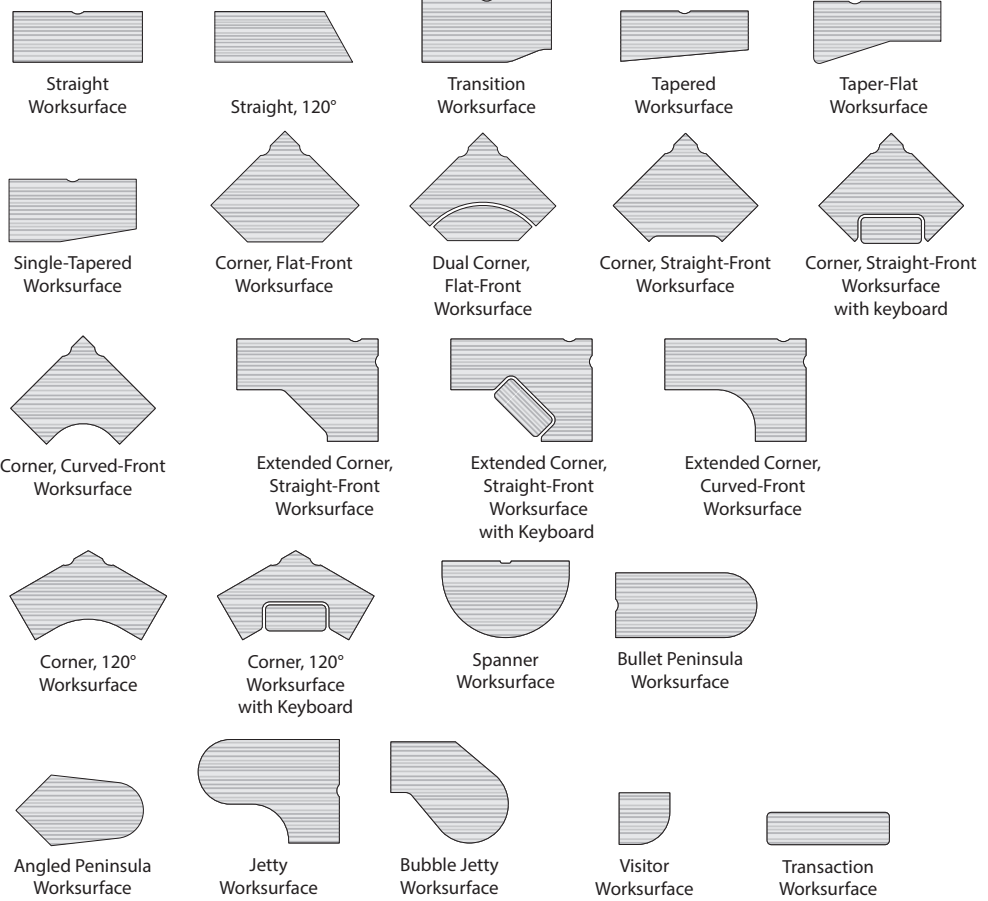

Surface Materials

# Wood Veneer Grain Directions

**The appearance of wood veneer** may change slightly depending on the angle from which it is viewed. This natural phenomenon is called polarization, and it can be seen on natural veneer, and to a lesser extent on composite veneer. Polarization is often noticed on worksurfaces installed at a 90-degree angle with each other. Please refer to the following illustrations for an understanding of grain direction on your installation.

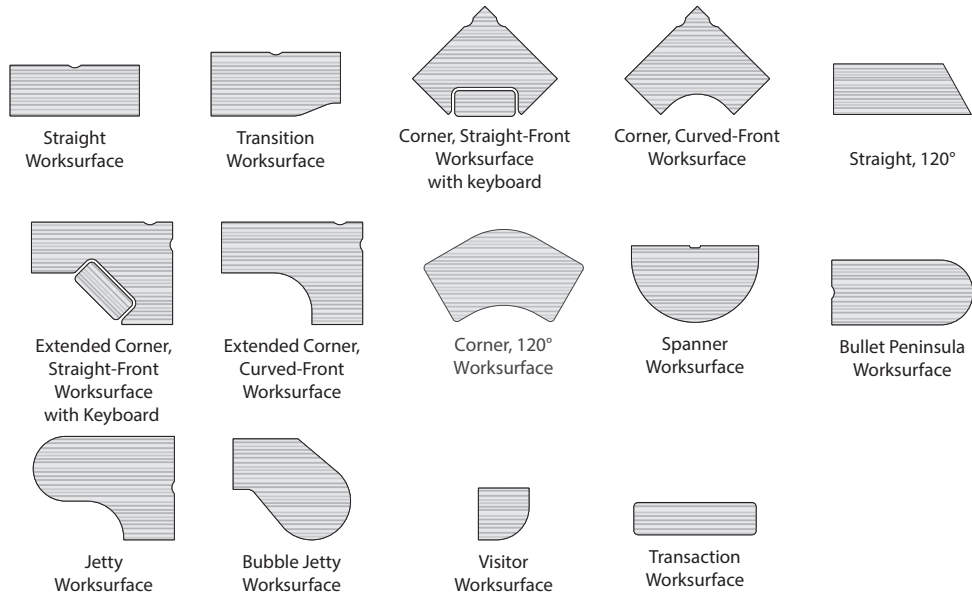

---

# Resources

<b>Lock and Keying</b>	<b>374</b>
<b>Style Number Index</b>	<b>378</b>

# Lock and Keying

## For TS Series Storage

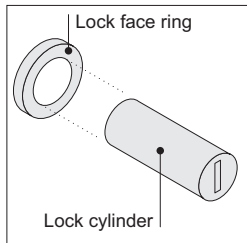

**Front-removable lock cylinders** can be installed or removed in the field with a special tool. This feature allows you to field install lock cylinders after the furniture is installed.

**All locks** are designated with key numbers. You can specify a key number; however, if you don't specify a key number, the locks in your order will be keyed random.

**Two types** of locks are available—the standard keying system (FR series) and the master keying system (XF series). All the locks in the XF series can be opened with a single master key.

### Standard Keying

**All products** are standard keyed random.

### Step 1

**Furniture will be shipped with a plastic shipping plug.** Specify lock cylinder and keying options separately. Only products with factory-installed lock mechanisms can accept lock cylinders in the field.

*Tip: Be sure to specify a lock color number (9201 Polished Chrome or 9250 Ember Chrome) for the lock face ring.*

### Step 2

**Order enough lock cylinders** to fill each lock location. You must also order a lock tool.

*Tip: Lock tools are reusable. You don't need to order additional lock tools with every furniture order.* Lock cylinders and the installation tool will be shipped separately so that you can install the locks when you are ready.

**To specify lock cylinders**, list the total number of lock cylinders that you want with the appropriate style number. If you are specifying key numbers, list the breakdown of the quantity of each key number.

**An example** of how your order should look is shown below:

Example:  
 10 LOCK9201FR FR320  
 5 LOCK9201FR FR350  
 15 LOCK9201XF XF1100  
 30 Total

1 877102003SR standard lock tool  
 1 877102002SR master lock tool

### Keying Options

**Key random** means that the locks will be assigned arbitrarily at the factory with key numbers ranging from FR305 to FR454.

*Tip: Random keying can mean that different furniture units will have the same key number. If you must have all locks keyed differently, you should specify key numbers for all locks.*

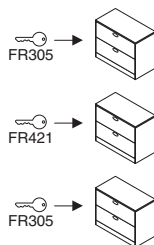

**Key specific** means that you can specify any key number from FR305 to FR454. This option can be used to key all the furniture units in a workstation or department the same.

*Tip: Designate the quantity per key number in your specification when ordering more than one product with the same style number.*

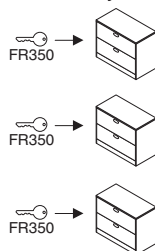

**Key consecutive** means that you can specify lock numbers in a consecutive order to ensure that no two locks have the same key number until the key sequence repeats. You must select a beginning key number from FR305 to FR454.

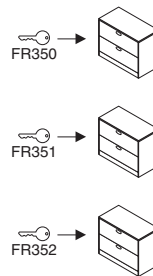

**Master key consecutive** means that you can specify lock numbers in a consecutive order to ensure that no two locks have the same key number until the key sequence repeats. You must select a beginning key number from XF1001 to XF1150. All the locks in the XF series can be opened with a master key.

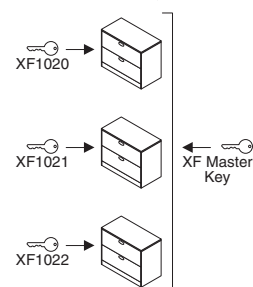

**Master key random** means that the locks will be assigned arbitrarily at the factory with key numbers ranging from XF1001 to XF1150. All XF locks can be opened with a master key.

*Tip: Random keying can mean that different furniture units will have the same key number. If you must have all locks keyed differently, you should specify key numbers for all locks.*

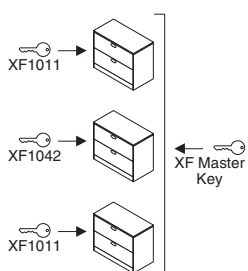

**Master key specific** means that you can specify any key number from XF1001 to XF1150. All the locks in the XF series can be opened with a master key.

*Tip: Designate the quantity per key number in your specification when ordering more than one product with the same style number.*

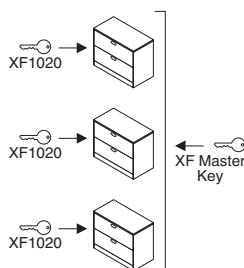

## For Universal Steel Storage Products

**All locking products** are standard with factory-installed, keyed-random locks. Consecutive, specific, and random keying are available as field-installed options.

*Exception: Individual locking drawers are only available with field-installed locks.*

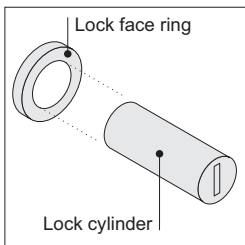

**Locks** consist of a factory- or field-installed lock cylinder and a factory-installed lock face ring.

**Two types of locks** are available—the standard keying system (FR series) and the master keying system (XF series). All the locks in the XF series can be opened with a single master key.

### Factory-Installed Keying

**Factory-installed locks** are always key random (standard) or master key random (option). Key random means that the locks will be assigned arbitrarily at the factory with key numbers ranging from FR305 to FR454 (Master keying numbers: XF1001 to XF1150). All locks within a unit will be keyed alike.

*Tip: Random keying can mean that different furniture units will have the same key number. If you must have all locks keyed differently, you should specify field-installed, key specific or key consecutive lock cylinders.*

▶ See below.

#### Key Random

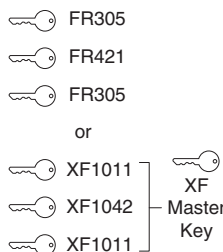

#### Required to Specify

<b>Master key random</b>	+\$36	Specify with master key random.
--------------------------	-------	---------------------------------

### Field-Installed Keying

**Field-installed locks** are only available on products that include factory-installed lock mechanisms.

**Specify "plug"** when specifying furniture, and the product will ship with a plastic plug in place of the lock cylinder.

**Front-removable lock cylinders** must be specified separately. You must also order a special lock tool to install or remove lock cylinders in the field.

*Tip: Lock tools are reusable. You do not need to order additional lock tools with every furniture order.*

**Lock cylinders** will be shipped separately so that you can install the locks when you are ready.

**Three keying choices** are available for field installation—random (standard), specific, and consecutive. All three are also available with master keying, which means that all locks can be opened with a single master key.

**Key random** means that the locks will be assigned arbitrarily at the factory with key numbers ranging from FR305 to FR454 (Master keying numbers: XF1001 to XF1150).

*Tip: Random keying can mean that different furniture units will have the same key number. If you must have all locks keyed differently, you should specify key specific or key consecutive lock cylinders.*

#### Key Random

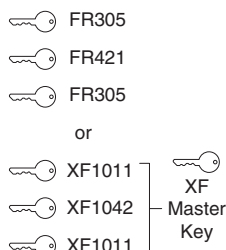

**Key specific** means that you can specify any key number from FR305 to FR454 (Master keying numbers: XF1001 to XF1150). This option can be used to key all the furniture units in a workstation or department the same.

*Tip: Designate the quantity per key number in your specification.*

▶ See example at right.

#### Key Specific

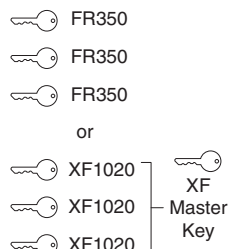

**Key consecutive** means that you can specify lock numbers in a consecutive order to ensure that no two locks have the same key number until the key sequence repeats. You must select a beginning key number from FR305 to FR454 (Master keying numbers: XF1001 to XF1150).

#### Key Consecutive

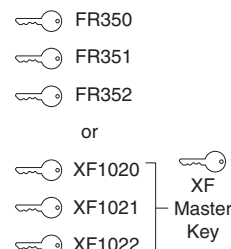

**Example** of a typical lock cylinder specification is shown below:

10	LOCK9201FR	FR320
5	LOCK9201FR	FR350
15	LOCK9201XF	XF1100
30	Total	
1	877102003SR	standard lock tool
1	877102002SR	master lock tool

Resources

## Field-Installed Lock Cylinders

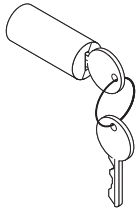

Tip: Lock price is included in price of furniture with locks.

Tip: For replacement lock cylinders, refer to Service Parts.

Standard Includes		Required to Specify
<ul style="list-style-type: none"> <li>Lock cylinder: 9201 Polished Chrome or 9250 Ember Chrome</li> <li>Two keys</li> </ul>		1 Style number 2 Options, if selected (see below)

Options	U.S. Price	Required to Specify
<b>Key specific</b>	No cost	Select key number from FR305–FR454.
<b>Key consecutive</b>	No cost	Specify <i>key consecutive</i> and select beginning key number from FR305–FR454.
<b>Master key random</b>	+\$36 each	Specify <i>master key random</i> .
<b>Master key specific</b>	+\$36 each	Specify key number from XF1001–XF1150.
<b>Master key consecutive</b>	+\$36 each	Specify <i>master key consecutive</i> and select beginning key number from XF1001–XF1150.

Specification Information		
Color	Style Number	U.S. Base Price

### FR Series (Standard Keying System)—Lock Cylinder

Polished Chrome	<b>LOCK9201FR</b>	No cost
Ember Chrome	<b>LOCK9250FR</b>	No cost

Tip: You can change lock cylinders in the field by using the appropriate lock tool.

### Standard Lock Tool

	<b>877102003SR</b>	\$36
--	--------------------	------

### XF Series (Master Keying System)—Lock Cylinder

Polished Chrome	<b>LOCK9201XF</b>	No additional cost. Price included in price of furniture with master-keyed locks.
Ember Chrome	<b>LOCK9250XF</b>	No additional cost. Price included in price of furniture with master-keyed locks.

### Master Lock Tool

	<b>877102002SR</b>	\$36
--	--------------------	------



**For Canadian Pricing**  
 Multiply U.S. Price by the Canadian price factor.  
 ▶ See page 1 for details.



# Style Number Index

Style Number	Page	Description
<b>877102002SR</b>	376	Master Lock Tool
<b>877102003SR</b>	376	Standard Lock Tool
<b>AWAG2</b>	261	Round Grommet
<b>DVSS2912</b>	269	Divisio Side Screen
<b>L52FT</b>	354	Bottomline
<b>L52FTCHI</b>	354	Bottomline
<b>L52FTS</b>	354	Bottomline
<b>L52FTY</b>	354	Bottomline
<b>L53FT</b>	354	Bottomline
<b>L53FTCHI</b>	354	Bottomline
<b>L53FTS</b>	354	Bottomline
<b>L53FTY</b>	354	Bottomline
<b>L54FT</b>	354	Bottomline
<b>L54FTCHI</b>	354	Bottomline
<b>L54FTS</b>	354	Bottomline
<b>L54FTY</b>	354	Bottomline
<b>LLL17</b>	356	LED Linear Shelf Light
<b>LLL17YA</b>	356	LED Linear Shelf Light
<b>LLL17YB</b>	356	LED Linear Shelf Light
<b>LLL31</b>	356	LED Linear Shelf Light
<b>LLL31YB</b>	356	LED Linear Shelf Light
<b>LLL44</b>	357	LED Linear Shelf Light
<b>LLL44YB</b>	357	LED Linear Shelf Light
<b>LLL58</b>	357	LED Linear Shelf Light
<b>LLL58YB</b>	357	LED Linear Shelf Light
<b>LOCK9201FR</b>	376	Lock Cylinder
<b>LOCK9201XF</b>	376	Lock Cylinder
<b>LOCK9250FR</b>	376	Lock Cylinder
<b>LOCK9250XF</b>	376	Lock Cylinder
<b>LS1FSC</b>	353	Daisy Chain Cord
<b>LS6FSC</b>	353	Daisy Chain Cord
<b>LSL18</b>	355	LED Light
<b>LSL18YA</b>	355	LED Light
<b>LSL18YB</b>	355	LED Light
<b>LSM24K</b>	352	Standard Light
<b>LSM24KC</b>	352	Standard Light
<b>LSM24KD</b>	352	Standard Light
<b>LSM36K</b>	352	Standard Light
<b>LSM36KC</b>	352	Standard Light
<b>LSM36KD</b>	352	Standard Light
<b>LSM48K</b>	352	Standard Light
<b>LSM48KC</b>	352	Standard Light
<b>LSM48KD</b>	352	Standard Light
<b>PAB12</b>	334	Attachment Cable
<b>PAB12M</b>	334	Attachment Cable
<b>PTDMGB3</b>	216	Pwr Comm Sphere
<b>R30MBB</b>	278, 307	Flexible Mb Surf
<b>R36MBB</b>	278, 307	Flexible Mb Surf
<b>R42MBB</b>	278, 307	Flexible Mb Surf
<b>R48MBB</b>	278, 307	Flexible Mb Surf
<b>RAACT1</b>	333	Counterweight Pkg
<b>RAACT2</b>	333	Counterweight Pkg
<b>RAACT3</b>	333	Counterweight Pkg
<b>RAACW1</b>	332	Counterweight Pkg
<b>RAACW2</b>	332	Counterweight Pkg

Style Number	Page	Description
<b>RAACW3</b>	332	Counterweight Pkg
<b>RAACW30</b>	332	Counterweight Pkg
<b>RAACW36</b>	332	Counterweight Pkg
<b>RAACW4</b>	332	Counterweight Pkg
<b>RAACW42</b>	332	Counterweight Pkg
<b>RAACW5</b>	332	Counterweight Pkg
<b>RAACW6</b>	332	Counterweight Pkg
<b>RAACW7</b>	332	Counterweight Pkg
<b>RAACW8</b>	332	Counterweight Pkg
<b>RAACWD</b>	332	Counterweight Pkg
<b>RAACWE</b>	332	Counterweight Pkg
<b>RAACWF</b>	332	Counterweight Pkg
<b>RAACWR</b>	332	Counterweight Retro Kit
<b>RAANBRK</b>	333	Anchor Bracket Pkg
<b>RBB24LTAK</b>	302	U In the Case Bin
<b>RBB24QTAK</b>	299	U Ovr the Case Bin
<b>RBB24TAK</b>	301	U In the Case Bin
<b>RBB24WTAK</b>	302	U In the Case Bin
<b>RBB30LTAK</b>	302	U In the Case Bin
<b>RBB30QTAK</b>	299	U Ovr the Case Bin
<b>RBB30TAK</b>	301	U In the Case Bin
<b>RBB30WTAK</b>	302	U In the Case Bin
<b>RBB36LTAK</b>	302	U In the Case Bin
<b>RBB36QTAK</b>	299	U Ovr the Case Bin
<b>RBB36TAK</b>	301	U In the Case Bin
<b>RBB36WTAK</b>	302	U In the Case Bin
<b>RBB42LTAK</b>	302	U In the Case Bin
<b>RBB42QTAK</b>	299	U Ovr the Case Bin
<b>RBB42TAK</b>	301	U In the Case Bin
<b>RBB42WTAK</b>	302	U In the Case Bin
<b>RBB48LTAK</b>	302	U In the Case Bin
<b>RBB48QTAK</b>	299	U Ovr the Case Bin
<b>RBB48TAK</b>	301	U In the Case Bin
<b>RBB48WTAK</b>	302	U Ovr the Case Bin
<b>RBB60LTAK</b>	302	U In the Case Bin
<b>RBB60QTAK</b>	299	U Ovr the Case Bin
<b>RBB60TAK</b>	301	U In the Case Bin
<b>RBB60WTAK</b>	302	U In the Case Bin
<b>RBB66LTAK</b>	302	U In the Case Bin
<b>RBB66QTAK</b>	299	U Ovr the Case Bin
<b>RBB66TAK</b>	301	U In the Case Bin
<b>RBB66WTAK</b>	302	U In the Case Bin
<b>RBB72LTAK</b>	302	U In the Case Bin
<b>RBB72QTAK</b>	299	U Ovr the Case Bin
<b>RBB72TAK</b>	301	U In the Case Bin
<b>RBB72WTAK</b>	302	U In the Case Bin
<b>RBKHWM24</b>	304	Wall Bracket
<b>RBKHWM30</b>	304	Wall Bracket
<b>RBKHWM36</b>	304	Wall Bracket
<b>RBKHWM42</b>	304	Wall Bracket
<b>RBKHWM48</b>	304	Wall Bracket
<b>RBKHWM60</b>	304	Wall Bracket
<b>RBKHWM70</b>	304	Wall Bracket
<b>RBKHWM72</b>	304	Wall Bracket
<b>RBKVOFM</b>	305	Vert Off-Module Brkt

Style Number	Page	Description	Style Number	Page	Description
<b>RCHE1715</b>	295	Basic Cushion Enhanced	<b>RLF18421B_</b>	313	U 1.5-High Lat File
<b>RCHE1830</b>	316	Basic Cushion Enhanced	<b>RLF18421C_</b>	314	U 1.5-High Lat File
<b>RCHE1836</b>	316	Basic Cushion Enhanced	<b>RLF18421D_</b>	314	U 1.5-High Lat File
<b>RCHE1842</b>	316	Basic Cushion Enhanced	<b>RLF18422_</b>	314	U Lat File
<b>RCHE2315</b>	295	Basic Cushion Enhanced	<b>RLF18423_</b>	331	Univ Lat File
<b>RCHE2430</b>	316	Basic Cushion Enhanced	<b>RLF18424_</b>	331	Univ Lat File
<b>RCHE2436</b>	316	Basic Cushion Enhanced	<b>RLF18425_</b>	331	Univ Lat File
<b>RDD182448LA_</b>	324	U Dual Door Tower	<b>RLF24301A_</b>	313	U 1.5-High Lat File
<b>RDD182448LB_</b>	324	U Dual Door Tower	<b>RLF24301B_</b>	313	U 1.5-High Lat File
<b>RDD182448RA_</b>	326	U Dual Door Tower	<b>RLF24301C_</b>	314	U 1.5-High Lat File
<b>RDD182448RB_</b>	326	U Dual Door Tower	<b>RLF24301D_</b>	314	U 1.5-High Lat File
<b>RDD18244LA_</b>	324	U Dual Door Tower	<b>RLF24302_</b>	314	U Lat File
<b>RDD18244LB_</b>	325	U Dual Door Tower	<b>RLF24303_</b>	331	Univ Lat File
<b>RDD18244RA_</b>	326	U Dual Door Tower	<b>RLF24304_</b>	331	Univ Lat File
<b>RDD18244RB_</b>	327	U Dual Door Tower	<b>RLF24305_</b>	331	Univ Lat File
<b>RDD18245LC_</b>	325	U Dual Door Tower	<b>RLF24361A_</b>	313	U 1.5-High Lat File
<b>RDD18245LD_</b>	325	U Dual Door Tower	<b>RLF24361B_</b>	313	U 1.5-High Lat File
<b>RDD18245RC_</b>	327	U Dual Door Tower	<b>RLF24361C_</b>	314	U 1.5-High Lat File
<b>RDD18245RD_</b>	327	U Dual Door Tower	<b>RLF24361D_</b>	314	U 1.5-High Lat File
<b>RDD242448LA_</b>	324	U Dual Door Tower	<b>RLF24362_</b>	314	U Lat File
<b>RDD242448LB_</b>	324	U Dual Door Tower	<b>RLF24363_</b>	331	Univ Lat File
<b>RDD242448RA_</b>	326	U Dual Door Tower	<b>RLF24364_</b>	331	Univ Lat File
<b>RDD242448RB_</b>	326	U Dual Door Tower	<b>RLF24365_</b>	331	Univ Lat File
<b>RDD24244LA_</b>	324	U Dual Door Tower	<b>RPCW</b>	290	U Ped Counterweight
<b>RDD24244LB_</b>	325	U Dual Door Tower	<b>RPDC1830_</b>	317	Cushion Top
<b>RDD24244RA_</b>	326	U Dual Door Tower	<b>RPDC1836_</b>	317	Cushion Top
<b>RDD24244RB_</b>	327	U Dual Door Tower	<b>RPDC1842_</b>	317	Cushion Top
<b>RDD24245LC_</b>	325	U Dual Door Tower	<b>RPDC2430_</b>	317	Cushion Top
<b>RDD24245LD_</b>	325	U Dual Door Tower	<b>RPDC2436_</b>	317	Cushion Top
<b>RDD24245RC_</b>	327	U Dual Door Tower	<b>RPF1827A_</b>	289	U Fixed Pedestal
<b>RDD24245RD_</b>	327	U Dual Door Tower	<b>RPF1827B_</b>	289	U Fixed Pedestal
<b>RDIV</b>	304	Dividers	<b>RPF2427A_</b>	289	U Fixed Pedestal
<b>RDV1506</b>	273	Dividers	<b>RPF2427B_</b>	289	U Fixed Pedestal
<b>RDV1512</b>	273	Dividers	<b>RPF3027A_</b>	289	U Fixed Pedestal
<b>RDV151210</b>	273	Dividers	<b>RPF3027B_</b>	289	U Fixed Pedestal
<b>RLF18301_</b>	313	U One-High Lat File	<b>RPM1821C_</b>	294	U Mobile Pedestal
<b>RLF18301A_</b>	313	U 1.5-High Lat File	<b>RPM1827A_</b>	294	U Mobile Pedestal
<b>RLF18301B_</b>	313	U 1.5-High Lat File	<b>RPM1827B_</b>	294	U Mobile Pedestal
<b>RLF18301C_</b>	314	U 1.5-High Lat File	<b>RPM2421C_</b>	294	U Mobile Pedestal
<b>RLF18301D_</b>	314	U 1.5-High Lat File	<b>RPM2427A_</b>	294	U Mobile Pedestal
<b>RLF18302_</b>	314	U Lat File	<b>RPM2427B_</b>	294	U Mobile Pedestal
<b>RLF18303_</b>	331	Univ Lat File	<b>RPXCK2718F</b>	291	U Conv Kit
<b>RLF18304_</b>	331	Univ Lat File	<b>RPXCK2718P</b>	291	U Conv Kit
<b>RLF18305_</b>	331	Univ Lat File	<b>RPXCK2724F</b>	291	U Conv Kit
<b>RLF18361_</b>	313	U One-High Lat File	<b>RPXCK2724P</b>	291	U Conv Kit
<b>RLF18361A_</b>	313	U 1.5-High Lat File	<b>RPXCK2730F</b>	291	U Conv Kit
<b>RLF18361B_</b>	313	U 1.5-High Lat File	<b>RPXCK2730P</b>	291	U Conv Kit
<b>RLF18361C_</b>	314	U 1.5-High Lat File	<b>RPXDPT</b>	273	Pencil Tray
<b>RLF18361D_</b>	314	U 1.5-High Lat File	<b>RPXF TAKFP</b>	290	U Fil Prd Frnt Ped
<b>RLF18362_</b>	314	U Lat File	<b>RPXF TAKPP</b>	290	U Fil Prd Frnt Ped
<b>RLF18363_</b>	331	Univ Lat File	<b>RPXTC24F</b>	294	U Ped Cushion Top
<b>RLF18364_</b>	331	Univ Lat File	<b>RPXTC24P</b>	294	U Ped Cushion Top
<b>RLF18365_</b>	331	Univ Lat File	<b>RPXTCH24F</b>	294	U Ped Cushion Top
<b>RLF18421_</b>	313	U One-High Lat File	<b>RPXTCH24P</b>	294	U Ped Cushion Top
<b>RLF18421A_</b>	313	U 1.5-High Lat File	<b>RQS182448LA_</b>	320	U Open Side Tower

## Style Number Index, continued

Style Number	Page	Description
<b>RQS182448RA_</b>	321	U Open Side Tower
<b>RQS18244LA_</b>	320	U Open Side Tower
<b>RQS18244RA_</b>	321	U Open Side Tower
<b>RQS18245LC_</b>	320	U Open Side Tower
<b>RQS18245RC_</b>	321	U Open Side Tower
<b>RQS242448LA_</b>	320	U Open Side Tower
<b>RQS242448RA_</b>	321	U Open Side Tower
<b>RQS24244LA_</b>	320	U Open Side Tower
<b>RQS24244RA_</b>	321	U Open Side Tower
<b>RQS24245LC_</b>	320	U Open Side Tower
<b>RQS24245RC_</b>	321	U Open Side Tower
<b>RSB36LTAK</b>	297	U Sld Dr Bin Lam Frnt
<b>RSB36TAK</b>	297	U Sldg Dr Bin Stil Frnt
<b>RSB36WTAK</b>	297	U Sldg Dr Bin Wd Frnt
<b>RSB42LTAK</b>	297	U Sld Dr Bin Lam Frnt
<b>RSB42TAK</b>	297	U Sldg Dr Bin Stil Frnt
<b>RSB42WTAK</b>	297	U Sldg Dr Bin Wd Frnt
<b>RSB48LTAK</b>	297	U Sld Dr Bin Lam Frnt
<b>RSB48TAK</b>	297	U Sldg Dr Bin Stil Frnt
<b>RSB48WTAK</b>	297	U Sldg Dr Bin Wd Frnt
<b>RSB60LTAK</b>	297	U Sld Dr Bin Lam Frnt
<b>RSB60TAK</b>	297	U Sldg Dr Bin Stil Frnt
<b>RSB60WTAK</b>	297	U Sldg Dr Bin Wd Frnt
<b>RSB66LTAK</b>	297	U Sld Dr Bin Lam Frnt
<b>RSB66TAK</b>	297	U Sldg Dr Bin Stil Frnt
<b>RSB66WTAK</b>	297	U Sldg Dr Bin Wd Frnt
<b>RSB72LTAK</b>	297	U Sld Dr Bin Lam Frnt
<b>RSB72TAK</b>	297	U Sldg Dr Bin Stil Frnt
<b>RSB72WTAK</b>	297	U Sldg Dr Bin Wd Frnt
<b>RSC18301A_</b>	313	U One-High Lat File
<b>RSC18361A_</b>	313	U One-High Lat File
<b>RSC18421A_</b>	313	U One-High Lat File
<b>RSH24TAK</b>	303	U Shelf
<b>RSH30TAK</b>	303	U Shelf
<b>RSH36TAK</b>	303	U Shelf
<b>RSH42TAK</b>	303	U Shelf
<b>RSH48TAK</b>	303	U Shelf
<b>RSH60TAK</b>	303	U Shelf
<b>RSH72TAK</b>	303	U Shelf
<b>RSS24TAK</b>	308	Slim Shelf
<b>RSS30TAK</b>	308	Slim Shelf
<b>RSS36TAK</b>	308	Slim Shelf
<b>RSS42TAK</b>	308	Slim Shelf
<b>RSS48TAK</b>	308	Slim Shelf
<b>RSS60TAK</b>	308	Slim Shelf
<b>RSS72TAK</b>	308	Slim Shelf
<b>RSS96TAK</b>	308	Slim Shelf
<b>RUK24TAK</b>	305	Stnd OH Upmnt Pkg
<b>RUK30TAK</b>	305	Stnd OH Upmnt Pkg
<b>RUK36TAK</b>	305	Stnd OH Upmnt Pkg
<b>RUK42TAK</b>	305	Stnd OH Upmnt Pkg
<b>RUK48TAK</b>	305	Stnd OH Upmnt Pkg
<b>RUK60TAK</b>	305	Stnd OH Upmnt Pkg
<b>RUK72TAK</b>	305	Stnd OH Upmnt Pkg
<b>RXADRL15</b>	273	Rails

Style Number	Page	Description
<b>TS2CW1</b>	283	Counterweight Pkg
<b>TS2CW2</b>	283	Counterweight Pkg
<b>TS2F130A</b>	281	Freestanding Lat File
<b>TS2F130B</b>	281	Freestanding Lat File
<b>TS2F136A</b>	281	Freestanding Lat File
<b>TS2F136B</b>	281	Freestanding Lat File
<b>TS2F230UL</b>	280	Under-Wksf Lat File
<b>TS2F236UL</b>	280	Under-Wksf Lat File
<b>TS2FDV</b>	282	Lat File Dwr Div
<b>TS2FFTBR</b>	283	Lateral File Rail
<b>TS2FHF30</b>	282	Lat File Frame
<b>TS2FHF30A</b>	282	Lat File Frame
<b>TS2FHF36</b>	282	Lat File Frame
<b>TS2FILLER</b>	272	Pedestal Filler
<b>TS2PBBF22M</b>	274	Mobile Ped
<b>TS2PBBF22U</b>	272	Under-Wksf Ped
<b>TS2PBBF28U</b>	272	Under-Wksf Ped
<b>TS2PBDD</b>	276	Box Dwr Divider
<b>TS2PBF19M</b>	274	Mobile Ped
<b>TS2PBF22M</b>	274	Mobile Ped
<b>TS2PBF22MC</b>	275	Mobile Ped
<b>TS2PBF22MCH</b>	275	Mobile Ped
<b>TS2PFDD</b>	276	File Dwr Divider
<b>TS2PFF22M</b>	274	Mobile Ped
<b>TS2PFF22U</b>	272	Under-Wksf Ped
<b>TS2PFF28U</b>	272	Under-Wksf Ped
<b>TS2PPT</b>	276	Pencil Tray
<b>TS2TDME</b>	285	Tower Too Dome
<b>TS2TW54LC</b>	284	Tower Too
<b>TS2TW54LSC</b>	284	Tower Too
<b>TS2TW54RC</b>	284	Tower Too
<b>TS2TW54RSC</b>	284	Tower Too
<b>TS2TW66LC</b>	284	Tower Too
<b>TS2TW66LSC</b>	284	Tower Too
<b>TS2TW66RC</b>	284	Tower Too
<b>TS2TW66RSC</b>	284	Tower Too
<b>TS2TWR54L</b>	284	Tower Too
<b>TS2TWR54LS</b>	284	Tower Too
<b>TS2TWR54R</b>	284	Tower Too
<b>TS2TWR54RS</b>	284	Tower Too
<b>TS2TWR66L</b>	284	Tower Too
<b>TS2TWR66LS</b>	284	Tower Too
<b>TS2TWR66R</b>	284	Tower Too
<b>TS2TWR66RS</b>	284	Tower Too
<b>TS2TWR548L</b>	285	Tower Too
<b>TS2TWR548LS</b>	285	Tower Too
<b>TS2TWR548R</b>	285	Tower Too
<b>TS2TWR548RS</b>	285	Tower Too
<b>TS2TWR54L</b>	285	Tower Too
<b>TS2TWR54LS</b>	285	Tower Too
<b>TS2TWR54R</b>	285	Tower Too
<b>TS2TWR54RS</b>	285	Tower Too
<b>TS2TWR66L</b>	285	Tower Too
<b>TS2TWR66LS</b>	285	Tower Too
<b>TS2TWR66R</b>	285	Tower Too
<b>TS2TWR66RS</b>	285	Tower Too
<b>TS2TWR66L</b>	285	Tower Too
<b>TS2TWR66LS</b>	285	Tower Too
<b>TS2TWR66R</b>	285	Tower Too

Style Number	Page	Description	Style Number	Page	Description
<b>TS2TWRS66RS</b>	285	Tower Too	<b>TSAE33DC20SB</b>	196	Kick Dplx Recept
<b>TS2TWS48LC</b>	285	Tower Too	<b>TSAE34DA15SB</b>	196	Kick Dplx Recept
<b>TS2TWS48LSC</b>	285	Tower Too	<b>TSAE34DA20SB</b>	196	Kick Dplx Recept
<b>TS2TWS48RC</b>	285	Tower Too	<b>TSAE34DB15SB</b>	196	Kick Dplx Recept
<b>TS2TWS48RSC</b>	285	Tower Too	<b>TSAE34DB20SB</b>	196	Kick Dplx Recept
<b>TS2TWS54LC</b>	285	Tower Too	<b>TSAE34DC15SB</b>	196	Kick Dplx Recept
<b>TS2TWS54LSC</b>	285	Tower Too	<b>TSAE34DC20SB</b>	196	Kick Dplx Recept
<b>TS2TWS54RC</b>	285	Tower Too	<b>TSAE3ADD15SB</b>	196	Kick Dplx Recept
<b>TS2TWS54RSC</b>	285	Tower Too	<b>TSAE3ADD20SB</b>	196	Kick Dplx Recept
<b>TS2TWS66LC</b>	285	Tower Too	<b>TSAE3BDD15SB</b>	196	Kick Dplx Recept
<b>TS2TWS66LSC</b>	285	Tower Too	<b>TSAE3BDD20SB</b>	196	Kick Dplx Recept
<b>TS2TWS66RC</b>	285	Tower Too	<b>TSAE3CDD15SB</b>	196	Kick Dplx Recept
<b>TS2TWS66RSC</b>	285	Tower Too	<b>TSAE3CDD20SB</b>	196	Kick Dplx Recept
<b>TS714WSP</b>	263	U Support Plate	<b>TSAE986694B</b>	199	Kick Dplx Recept
<b>TS71824TB</b>	307	TB Use w/Wall Chan	<b>TSAE98669B</b>	199	Kick Dplx Recept
<b>TS71830TB</b>	307	TB Use w/Wall Chan	<b>TSAE98669SFB</b>	199	Kick Dplx Recept
<b>TS71836TB</b>	307	TB Use w/Wall Chan	<b>TSAEGROM</b>	216, 261	Grommet Pkg
<b>TS71842TB</b>	307	TB Use w/Wall Chan	<b>TSAEP342B</b>	197	Kick Power Pole
<b>TS71848TB</b>	307	TB Use w/Wall Chan	<b>TSAEP348B</b>	197	Kick Power Pole
<b>TS71860TB</b>	307	TB Use w/Wall Chan	<b>TSAEP354B</b>	197	Kick Power Pole
<b>TS71872TB</b>	307	TB Use w/Wall Chan	<b>TSAEP366B</b>	197	Kick Power Pole
<b>TS720WSP</b>	263	U Support Plate	<b>TSAEP442B</b>	197	Kick Power Pole
<b>TS742HB</b>	306	Horiz Brace	<b>TSAEP448B</b>	197	Kick Power Pole
<b>TS748HB</b>	306	Horiz Brace	<b>TSAEP454B</b>	197	Kick Power Pole
<b>TS760HB</b>	306	Horiz Brace	<b>TSAEP466B</b>	197	Kick Power Pole
<b>TS772HB</b>	306	Horiz Brace	<b>TSAEPC42</b>	198	Kick Cable Pole
<b>TS7BSWHC</b>	306	Wall Channels	<b>TSAEPC48</b>	198	Kick Cable Pole
<b>TS7PVWM</b>	358	Vertical Wire Mgr	<b>TSAEPC54</b>	198	Kick Cable Pole
<b>TS7TIEPLATE</b>	263	U Tie Plates	<b>TSAEPC66</b>	198	Kick Cable Pole
<b>TS7WKSPT</b>	263	Reinforcing Chan	<b>TSAERDP</b>	200	Comm Mdl Pkg
<b>TS7WKSPT39</b>	263	Reinforcing Chan	<b>TSAERDW</b>	200, 217	Comm Mdl Pkg
<b>TS7WKSPT48</b>	263	Reinforcing Chan	<b>TSAERPP</b>	200	Recept Pkg
<b>TS7WKSPT51</b>	263	Reinforcing Chan	<b>TSAERPW</b>	200, 217	Receptacle Pkg
<b>TS7WKSPT54</b>	263	Reinforcing Chan	<b>TSAEVWMZ20</b>	358	Kick Vert Wire Mgr
<b>TS7WKSPT60</b>	263	Reinforcing Chan	<b>TSAPB120</b>	191	Kick Connectors
<b>TS7WKSPT63</b>	263	Reinforcing Chan	<b>TSAPB120P</b>	191	Kick Connectors
<b>TS7WKSPT66</b>	263	Reinforcing Chan	<b>TSAPBCOH</b>	191	Kick Connector Pkg
<b>TS7WKSPT72</b>	263	Reinforcing Chan	<b>TSAPBOM</b>	192	Off-Mod Conn Univ
<b>TSAE31DA15SB</b>	196	Kick Dplx Recept	<b>TSAPBOM24</b>	192	Off-Mod Conn Panel
<b>TSAE31DA20SB</b>	196	Kick Dplx Recept	<b>TSAPBOM30</b>	192	Off-Mod Conn Panel
<b>TSAE31DB15SB</b>	196	Kick Dplx Recept	<b>TSAPBOM36</b>	192	Off-Mod Conn Panel
<b>TSAE31DB20SB</b>	196	Kick Dplx Recept	<b>TSAPBOM42</b>	192	Off-Mod Conn Panel
<b>TSAE31DC15SB</b>	196	Kick Dplx Recept	<b>TSAPBOM48</b>	192	Off-Mod Conn Panel
<b>TSAE31DC20SB</b>	196	Kick Dplx Recept	<b>TSAPBOM60</b>	192	Off-Mod Conn Panel
<b>TSAE32DA15SB</b>	196	Kick Dplx Recept	<b>TSAPBWS66</b>	191	Kick Connector Pkg
<b>TSAE32DA20SB</b>	196	Kick Dplx Recept	<b>TSAPDSO6636</b>	193	Kick Univ Sliding Pnl Dr
<b>TSAE32DB15SB</b>	196	Kick Dplx Recept	<b>TSAPDSO6642</b>	193	Kick Univ Sliding Pnl Dr
<b>TSAE32DB20SB</b>	196	Kick Dplx Recept	<b>TSAPDSO7836</b>	193	Kick Univ Sliding Pnl Dr
<b>TSAE32DC15SB</b>	196	Kick Dplx Recept	<b>TSAPDSO7842</b>	193	Kick Univ Sliding Pnl Dr
<b>TSAE32DC20SB</b>	196	Kick Dplx Recept	<b>TSAPF4224</b>	177	Kick Tack Acst Pnl
<b>TSAE33DA15SB</b>	196	Kick Dplx Recept	<b>TSAPF4230</b>	177	Kick Tack Acst Pnl
<b>TSAE33DA20SB</b>	196	Kick Dplx Recept	<b>TSAPF4236</b>	177	Kick Tack Acst Pnl
<b>TSAE33DB15SB</b>	196	Kick Dplx Recept	<b>TSAPF4242</b>	177	Kick Tack Acst Pnl
<b>TSAE33DB20SB</b>	196	Kick Dplx Recept	<b>TSAPF4248</b>	177	Kick Tack Acst Pnl
<b>TSAE33DC15SB</b>	196	Kick Dplx Recept	<b>TSAPF4260</b>	177	Kick Tack Acst Pnl

Style Number Index, continued

Style Number	Page	Description
TSAPF4824	177	Kick Tack Acst Pnl
TSAPF4830	177	Kick Tack Acst Pnl
TSAPF4836	177	Kick Tack Acst Pnl
TSAPF4842	177	Kick Tack Acst Pnl
TSAPF4848	177	Kick Tack Acst Pnl
TSAPF4860	177	Kick Tack Acst Pnl
TSAPF5424	177	Kick Tack Acst Pnl
TSAPF5430	177	Kick Tack Acst Pnl
TSAPF5436	177	Kick Tack Acst Pnl
TSAPF5442	177	Kick Tack Acst Pnl
TSAPF5448	177	Kick Tack Acst Pnl
TSAPF5460	177	Kick Tack Acst Pnl
TSAPF6624	177	Kick Tack Acst Pnl
TSAPF6630	177	Kick Tack Acst Pnl
TSAPF6636	177	Kick Tack Acst Pnl
TSAPF6642	177	Kick Tack Acst Pnl
TSAPF6648	177	Kick Tack Acst Pnl
TSAPF6660	177	Kick Tack Acst Pnl
TSAPG4224	177	Kick Glass Panel
TSAPG4230	177	Kick Glass Panel
TSAPG4236	177	Kick Glass Panel
TSAPG4242	177	Kick Glass Panel
TSAPG4248	177	Kick Glass Panel
TSAPG4824	177	Kick Glass Panel
TSAPG4830	177	Kick Glass Panel
TSAPG4836	177	Kick Glass Panel
TSAPG4842	177	Kick Glass Panel
TSAPG4848	177	Kick Glass Panel
TSAPG5424	177	Kick Glass Panel
TSAPG5430	177	Kick Glass Panel
TSAPG5436	177	Kick Glass Panel
TSAPG5442	177	Kick Glass Panel
TSAPG5448	177	Kick Glass Panel
TSAPG6624	177	Kick Glass Panel
TSAPG6630	177	Kick Glass Panel
TSAPG6636	177	Kick Glass Panel
TSAPG6642	177	Kick Glass Panel
TSAPG6648	177	Kick Glass Panel
TSAPL4224	179	Kick Segmented Pnl
TSAPL4230	179	Kick Segmented Pnl
TSAPL4236	179	Kick Segmented Pnl
TSAPL4242	179	Kick Segmented Pnl
TSAPL4248	179	Kick Segmented Pnl
TSAPL4260	179	Kick Segmented Pnl
TSAPL4824	179	Kick Segmented Pnl
TSAPL4830	179	Kick Segmented Pnl
TSAPL4836	179	Kick Segmented Pnl
TSAPL4842	179	Kick Segmented Pnl
TSAPL4848	179	Kick Segmented Pnl
TSAPL4860	179	Kick Segmented Pnl
TSAPL5424	181	Kick Segmented Pnl
TSAPL5430	181	Kick Segmented Pnl
TSAPL5436	181	Kick Segmented Pnl
TSAPL5442	181	Kick Segmented Pnl
TSAPL5448	181	Kick Segmented Pnl

Style Number	Page	Description
TSAPL5460	181	Kick Segmented Pnl
TSAPL6624	183	Kick Segmented Pnl
TSAPL6630	183	Kick Segmented Pnl
TSAPL6636	183	Kick Segmented Pnl
TSAPL6642	183	Kick Segmented Pnl
TSAPL6648	183	Kick Segmented Pnl
TSAPL6660	183	Kick Segmented Pnl
TSAPS1224G	185	Kick Panel Stacker
TSAPS1224T	185	Kick Panel Stacker
TSAPS1230G	185	Kick Panel Stacker
TSAPS1230T	185	Kick Panel Stacker
TSAPS1236G	185	Kick Panel Stacker
TSAPS1236T	185	Kick Panel Stacker
TSAPS1242G	185	Kick Panel Stacker
TSAPS1242T	185	Kick Panel Stacker
TSAPS1248G	185	Kick Panel Stacker
TSAPS1248T	185	Kick Panel Stacker
TSAPS1260G	185	Kick Panel Stacker
TSAPS1260T	185	Kick Panel Stacker
TSAPS1272G	185	Kick Panel Stacker
TSAPS1272T	185	Kick Panel Stacker
TSAPS1824G	185	Kick Panel Stacker
TSAPS1824T	185	Kick Panel Stacker
TSAPS1830G	185	Kick Panel Stacker
TSAPS1830T	185	Kick Panel Stacker
TSAPS1836G	185	Kick Panel Stacker
TSAPS1836T	185	Kick Panel Stacker
TSAPS1842G	185	Kick Panel Stacker
TSAPS1842T	185	Kick Panel Stacker
TSAPS1848G	185	Kick Panel Stacker
TSAPS1848T	185	Kick Panel Stacker
TSAPS1860G	185	Kick Panel Stacker
TSAPS1860T	185	Kick Panel Stacker
TSAPS1872G	185	Kick Panel Stacker
TSAPS1872T	185	Kick Panel Stacker
TSAPS2424G	185	Kick Panel Stacker
TSAPS2424T	185	Kick Panel Stacker
TSAPS2430G	185	Kick Panel Stacker
TSAPS2430T	185	Kick Panel Stacker
TSAPS2436G	185	Kick Panel Stacker
TSAPS2436T	185	Kick Panel Stacker
TSAPS2442G	185	Kick Panel Stacker
TSAPS2442T	185	Kick Panel Stacker
TSAPS2448G	185	Kick Panel Stacker
TSAPS2448T	185	Kick Panel Stacker
TSAPS2460G	185	Kick Panel Stacker
TSAPS2460T	185	Kick Panel Stacker
TSAPS2472G	185	Kick Panel Stacker
TSAPS2472T	185	Kick Panel Stacker
TSAPTC42	188	Kick Cor Trim Pkg
TSAPTC48	188	Kick Cor Trim Pkg
TSAPTC54	188	Kick Cor Trim Pkg
TSAPTC66	188	Kick Cor Trim Pkg
TSAPTCB5442	188	Kick Cor Trim Pkg
TSAPTCB6642	188	Kick Cor Trim Pkg

Style Number	Page	Description	Style Number	Page	Description
<b>TSAPTCB6654</b>	188	Kick Cor Trim Pkg	<b>TSATPL14</b>	215	Support Plate
<b>TSAPTCY12</b>	189	120° Vertical Corner Trims	<b>TSATPL20</b>	215	Support Plate
<b>TSAPTCY18</b>	189	120° Vertical Corner Trims	<b>TSATRC39</b>	215	Reinforcing Channel
<b>TSAPTCY24</b>	189	120° Vertical Corner Trims	<b>TSATRC48</b>	215	Reinforcing Channel
<b>TSAPTCY42</b>	189	120° Vertical Corner Trims	<b>TSATRC57</b>	215	Reinforcing Channel
<b>TSAPTCY48</b>	189	120° Vertical Corner Trims	<b>TSATRC72</b>	215	Reinforcing Channel
<b>TSAPTCY54</b>	189	120° Vertical Corner Trims	<b>TSATSIDE</b>	215	Kick Bracket
<b>TSAPTCY6</b>	189	120° Vertical Corner Trims	<b>TSATTIE</b>	215	Tie Plates
<b>TSAPTCY66</b>	189	120° Vertical Corner Trims	<b>TSAWLCC1836</b>	205	Curved Corner Wksf
<b>TSAPTE42</b>	186	Kick Vert EOR Trim	<b>TSAWLCC1842</b>	205	Curved Corner Wksf
<b>TSAPTE48</b>	186	Kick Vert EOR Trim	<b>TSAWLCC1848</b>	205	Curved Corner Wksf
<b>TSAPTE54</b>	186	Kick Vert EOR Trim	<b>TSAWLCC2436</b>	205	Curved Corner Wksf
<b>TSAPTE60</b>	186	Kick Vert EOR Trim	<b>TSAWLCC2442</b>	205	Curved Corner Wksf
<b>TSAPTE66</b>	186	Kick Vert EOR Trim	<b>TSAWLCC2448</b>	205	Curved Corner Wksf
<b>TSAPTE72</b>	186	Kick Vert EOR Trim	<b>TSAWLCC3048</b>	205	Curved Corner Wksf
<b>TSAPTE78</b>	186	Kick Vert EOR Trim	<b>TSAWLCF2436</b>	204	Straight Corner Wksf
<b>TSAPTXC12</b>	190	Kick Vert COH Trim	<b>TSAWLCF2442</b>	204	Straight Corner Wksf
<b>TSAPTXC18</b>	190	Kick Vert COH Trim	<b>TSAWLCF2448</b>	204	Straight Corner Wksf
<b>TSAPTXC24</b>	190	Kick Vert COH Trim	<b>TSAWLCF3048</b>	204	Straight Corner Wksf
<b>TSAPTXC6</b>	190	Kick Vert COH Trim	<b>TSAWLE2246</b>	207	Ext Curved Corner Wksf
<b>TSAPTXS12</b>	187	Kick Vert COH Trim	<b>TSAWLE2247</b>	207	Ext Curved Corner Wksf
<b>TSAPTXS18</b>	187	Kick Vert COH Trim	<b>TSAWLE2264</b>	206	Ext Curved Corner Wksf
<b>TSAPTXS24</b>	187	Kick Vert COH Trim	<b>TSAWLE2274</b>	206	Ext Curved Corner Wksf
<b>TSAPTXS36</b>	187	Kick Vert COH Trim	<b>TSAWLE2346</b>	207	Ext Curved Corner Wksf
<b>TSAPTXS6</b>	187	Kick Vert COH Trim	<b>TSAWLE2347</b>	207	Ext Curved Corner Wksf
<b>TSAPTXT12</b>	187	Kick Vert COH Trim	<b>TSAWLE2364</b>	206	Ext Curved Corner Wksf
<b>TSAPTXT18</b>	187	Kick Vert COH Trim	<b>TSAWLE2374</b>	206	Ext Curved Corner Wksf
<b>TSAPTXT24</b>	187	Kick Vert COH Trim	<b>TSAWLE3246</b>	207	Ext Curved Corner Wksf
<b>TSAPTXT36</b>	187	Kick Vert COH Trim	<b>TSAWLE3247</b>	207	Ext Curved Corner Wksf
<b>TSAPTXT6</b>	187	Kick Vert COH Trim	<b>TSAWLE3264</b>	206	Ext Curved Corner Wksf
<b>TSASHCL24</b>	279	Kick Common Shelf	<b>TSAWLE3274</b>	206	Ext Curved Corner Wksf
<b>TSASHCL30</b>	279	Kick Common Shelf	<b>TSAWLE3346</b>	207	Ext Curved Corner Wksf
<b>TSASHCL36</b>	279	Kick Common Shelf	<b>TSAWLE3347</b>	207	Ext Curved Corner Wksf
<b>TSASHCL42</b>	279	Kick Common Shelf	<b>TSAWLE3364</b>	206	Ext Curved Corner Wksf
<b>TSASHCL48</b>	279	Kick Common Shelf	<b>TSAWLE3374</b>	206	Ext Curved Corner Wksf
<b>TSASLCL24</b>	279	Kick Common Shelf	<b>TSAWLL2626</b>	212	Visitor Worksurface
<b>TSASLCL30</b>	279	Kick Common Shelf	<b>TSAWLL3232</b>	212	Visitor Worksurface
<b>TSASLCL36</b>	279	Kick Common Shelf	<b>TSAWLN50</b>	211	Kick Spanner Wksf
<b>TSASLCL42</b>	279	Kick Common Shelf	<b>TSAWLN51A</b>	211	Spanner Worksurface
<b>TSASLCL48</b>	279	Kick Common Shelf	<b>TSAWLN62</b>	211	Kick Spanner Wksf
<b>TSASUB24L</b>	277	Kick Bin	<b>TSAWLN63A</b>	211	Spanner Worksurface
<b>TSASUB30L</b>	277	Kick Bin	<b>TSAWLP3048</b>	209	Peninsula Worksurface
<b>TSASUB36L</b>	277	Kick Bin	<b>TSAWLP3060</b>	209	Peninsula Worksurface
<b>TSASUB42L</b>	277	Kick Bin	<b>TSAWLP3072</b>	209	Peninsula Worksurface
<b>TSASUB48L</b>	277	Kick Bin	<b>TSAWLPA2448</b>	210	Angled Peninsula Wksf
<b>TSASUB60L</b>	277	Kick Bin	<b>TSAWLPA3048</b>	210	Angled Peninsula Wksf
<b>TSASUB72L</b>	277	Kick Bin	<b>TSAWLR1824</b>	202	Straight Worksurface
<b>TSATCANT</b>	215	Kick Cantilever	<b>TSAWLR1830</b>	202	Straight Worksurface
<b>TSATEP24</b>	214	Kick On-Mod End Pnl	<b>TSAWLR1836</b>	202	Straight Worksurface
<b>TSATEP24S</b>	214	Kick On-Mod End Pnl	<b>TSAWLR1842</b>	202	Straight Worksurface
<b>TSATEP30</b>	214	Kick On-Mod End Pnl	<b>TSAWLR1848</b>	202	Straight Worksurface
<b>TSATEP30S</b>	214	Kick On-Mod End Pnl	<b>TSAWLR1854</b>	202	Straight Worksurface
<b>TSATH2711</b>	214	Kick H-Leg	<b>TSAWLR1860</b>	202	Straight Worksurface
<b>TSATH2720</b>	214	Kick H-Leg	<b>TSAWLR1866</b>	202	Straight Worksurface
<b>TSATP27</b>	214	Post Leg	<b>TSAWLR1872</b>	202	Straight Worksurface

Style Number Index, continued

Style Number	Page	Description
<b>TSAWLR2424</b>	202	Straight Worksurface
<b>TSAWLR2430</b>	202	Straight Worksurface
<b>TSAWLR2436</b>	202	Straight Worksurface
<b>TSAWLR2442</b>	202	Straight Worksurface
<b>TSAWLR2448</b>	202	Straight Worksurface
<b>TSAWLR2454</b>	202	Straight Worksurface
<b>TSAWLR2460</b>	202	Straight Worksurface
<b>TSAWLR2466</b>	202	Straight Worksurface
<b>TSAWLR2472</b>	202	Straight Worksurface
<b>TSAWLR3024</b>	202	Straight Worksurface
<b>TSAWLR3030</b>	202	Straight Worksurface
<b>TSAWLR3036</b>	202	Straight Worksurface
<b>TSAWLR3042</b>	202	Straight Worksurface
<b>TSAWLR3048</b>	202	Straight Worksurface
<b>TSAWLR3054</b>	202	Straight Worksurface
<b>TSAWLR3060</b>	202	Straight Worksurface
<b>TSAWLR3066</b>	202	Straight Worksurface
<b>TSAWLR3072</b>	202	Straight Worksurface
<b>TSAWLT1636</b>	213	Transaction Worksurface
<b>TSAWLT1642</b>	213	Transaction Worksurface
<b>TSAWLT1648</b>	213	Transaction Worksurface
<b>TSAWLT1660</b>	213	Transaction Worksurface
<b>TSAWLV2424</b>	212	Visitor Worksurface
<b>TSAWLV2430</b>	212	Visitor Worksurface
<b>TSAWLV3024</b>	212	Visitor Worksurface
<b>TSAWLV3030</b>	212	Visitor Worksurface
<b>TSAWLX1236</b>	203	Transition Worksurface
<b>TSAWLX1242</b>	203	Transition Worksurface
<b>TSAWLX1248</b>	203	Transition Worksurface
<b>TSAWLX2136</b>	203	Transition Worksurface
<b>TSAWLX2142</b>	203	Transition Worksurface
<b>TSAWLX2148</b>	203	Transition Worksurface
<b>TSAWLX2336</b>	203	Transition Worksurface
<b>TSAWLX2342</b>	203	Transition Worksurface
<b>TSAWLX2348</b>	203	Transition Worksurface
<b>TSAWLX3236</b>	203	Transition Worksurface
<b>TSAWLX3242</b>	203	Transition Worksurface
<b>TSAWLX3248</b>	203	Transition Worksurface
<b>TSAWLY2436</b>	208	120° Corner Worksurface
<b>TSAWLY2442</b>	208	120° Corner Worksurface
<b>TSAWLY2448</b>	208	120° Corner Worksurface
<b>UADJ</b>	268	U Adj-Hgt Leg
<b>UADJ4</b>	268	U Adj-Hgt Leg
<b>UADJ4C</b>	268	U Adj-Hgt Leg
<b>UADJ4M</b>	268	U Adj-Hgt Leg
<b>UADJC</b>	268	U Adj-Hgt Leg
<b>UADJCOL</b>	268	Adjustable Column
<b>UB223636</b>	250	U 120° WS CD
<b>UB224242</b>	250	U 120° WS CD
<b>UB224848</b>	250	U 120° WS CD
<b>UB333636</b>	250	U 120° WS CD
<b>UB334242</b>	250	U 120° WS CD
<b>UB334848</b>	250	U 120° WS CD
<b>UC114242</b>	244	U Cor WS, Front—CD
<b>UC124242</b>	244	U Cor WS, Front—CD

Style Number	Page	Description
<b>UC214242</b>	244	U Cor WS, Front—CD
<b>UC223636</b>	244	U Cor WS, Front—CD
<b>UC224242</b>	244	U Cor WS, Front—CD
<b>UC224848</b>	244	U Cor WS, Front—CD
<b>UC226060</b>	244	U Cor WS, Front—CD
<b>UC334242</b>	244	U Cor WS, Front—CD
<b>UC334848</b>	244	U Cor WS, Front—CD
<b>UCANT</b>	262	U On-Mod CANT
<b>UCC113636</b>	245	U Cor WS, Frnt—CD
<b>UCC114242</b>	245	U Cor WS, Frnt—CD
<b>UCC114848</b>	245	U Cor WS, Frnt—CD
<b>UCC124242</b>	245	U Cor WS, Frnt—CD
<b>UCC214242</b>	245	U Cor WS, Frnt—CD
<b>UCC223636</b>	245	U Cor WS, Frnt—CD
<b>UCC224242</b>	245	U Cor WS, Frnt—CD
<b>UCC224848</b>	245	U Cor WS, Frnt—CD
<b>UCC226060</b>	245	U Cor WS, Frnt—CD
<b>UCC334242</b>	245	U Cor WS, Frnt—CD
<b>UCC334848</b>	245	U Cor WS, Frnt—CD
<b>UCF223636</b>	242	U Cnr, FT-Frt WS—CD
<b>UCF224242</b>	242	U Cnr, FT-Frt WS—CD
<b>UCF224848</b>	242	U Cnr, FT-Frt WS—CD
<b>UCF334242</b>	242	U Cnr, FT-Frt WS—CD
<b>UCF334848</b>	242	U Cnr, FT-Frt WS—CD
<b>UCL</b>	267	U Dbl Post C-Leg
<b>UCOL</b>	268	Column
<b>UCSP</b>	264	U On-Md Cen Sprt Pnl
<b>UCSPS</b>	264	U On-Md Cen Sprt Pnl
<b>UDC224242</b>	243	U Dual Corner Wksf
<b>UDC224848</b>	243	U Dual Corner Wksf
<b>UDC334848</b>	243	U Dual Corner Wksf
<b>UDPL</b>	267	U Dbl Post Leg
<b>UE2202L</b>	247	U Ext Corner Wksf
<b>UE2208L</b>	247	U Ext Corner Wksf
<b>UE2220R</b>	247	U Ext Corner Wksf
<b>UE2222L</b>	247	U Ext Corner Wksf
<b>UE2222R</b>	247	U Ext Corner Wksf
<b>UE2226R</b>	247	U Ext Corner Wksf
<b>UE2228L</b>	247	U Ext Corner Wksf
<b>UE2262L</b>	247	U Ext Corner Wksf
<b>UE2268L</b>	247	U Ext Corner Wksf
<b>UE2280R</b>	247	U Ext Corner Wksf
<b>UE2282R</b>	247	U Ext Corner Wksf
<b>UE2286R</b>	247	U Ext Corner Wksf
<b>UE2308L</b>	247	U Ext Corner Wksf
<b>UE2328L</b>	247	U Ext Corner Wksf
<b>UE2368L</b>	247	U Ext Corner Wksf
<b>UE2380R</b>	247	U Ext Corner Wksf
<b>UE2382R</b>	247	U Ext Corner Wksf
<b>UE2386R</b>	247	U Ext Corner Wksf
<b>UE3208L</b>	247	U Ext Corner Wksf
<b>UE3228L</b>	247	U Ext Corner Wksf
<b>UE3268L</b>	247	U Ext Corner Wksf
<b>UE3280R</b>	247	U Ext Corner Wksf
<b>UE3282R</b>	247	U Ext Corner Wksf

Style Number	Page	Description	Style Number	Page	Description
<b>UE3286R</b>	247	U Ext Corner Wksf	<b>UJC3228L</b>	255	U Jetty WS, Fr CD
<b>UE3308L</b>	247	U Ext Corner Wksf	<b>UJC3268L</b>	255	U Jetty WS, Fr CD
<b>UE3328L</b>	247	U Ext Corner Wksf	<b>UJC3288L</b>	255	U Jetty WS, Fr CD
<b>UE3368L</b>	247	U Ext Corner Wksf	<b>UJC3328L</b>	255	U Jetty WS, Fr CD
<b>UE3380R</b>	247	U Ext Corner Wksf	<b>UJC3368L</b>	255	U Jetty WS, Fr CD
<b>UE3382R</b>	247	U Ext Corner Wksf	<b>UJC3382R</b>	255	U Jetty WS, Fr CD
<b>UE3386R</b>	247	U Ext Corner Wksf	<b>UJC3386R</b>	255	U Jetty WS, Fr CD
<b>UEC2202L</b>	249	U Ext Corner Wksf	<b>UJC3388L</b>	255	U Jetty WS, Fr CD
<b>UEC2208L</b>	249	U Ext Corner Wksf	<b>UJC3388R</b>	255	U Jetty WS, Fr CD
<b>UEC2220R</b>	249	U Ext Corner Wksf	<b>ULFF24F</b>	334	Undwksf Lat File Filler
<b>UEC2222L</b>	249	U Ext Corner Wksf	<b>ULFF24P</b>	334	Undwksf Lat File Filler
<b>UEC2222R</b>	249	U Ext Corner Wksf	<b>ULFF30F</b>	334	Undwksf Lat File Filler
<b>UEC2226R</b>	249	U Ext Corner Wksf	<b>ULFF30P</b>	334	Undwksf Lat File Filler
<b>UEC2228L</b>	249	U Ext Corner Wksf	<b>UNPL</b>	266	U Post Leg
<b>UEC2262L</b>	249	U Ext Corner Wksf	<b>UNPL4</b>	266	U Post Leg
<b>UEC2268L</b>	249	U Ext Corner Wksf	<b>UNPL4C</b>	266	U Post Leg
<b>UEC2280R</b>	249	U Ext Corner Wksf	<b>UNPL4M</b>	266	U Post Leg
<b>UEC2282R</b>	249	U Ext Corner Wksf	<b>UNPLC</b>	266	U Post Leg
<b>UEC2286R</b>	249	U Ext Corner Wksf	<b>UPA2448</b>	253	U Angled Pnsl WS CD
<b>UEC2308L</b>	249	U Ext Corner Wksf	<b>UPA2460</b>	253	U Angled Pnsl WS CD
<b>UEC2328L</b>	249	U Ext Corner Wksf	<b>UPA3048</b>	253	U Angled Pnsl WS CD
<b>UEC2368L</b>	249	U Ext Corner Wksf	<b>UPA3060</b>	253	U Angled Pnsl WS CD
<b>UEC2380R</b>	249	U Ext Corner Wksf	<b>UPBC2448</b>	252	Bullet Pnsl WS CD/FD
<b>UEC2382R</b>	249	U Ext Corner Wksf	<b>UPBC2460</b>	252	Bullet Pnsl WS CD/FD
<b>UEC2386R</b>	249	U Ext Corner Wksf	<b>UPBC2466</b>	252	Bullet Pnsl WS CD/FD
<b>UEC3208L</b>	249	U Ext Corner Wksf	<b>UPBC2472</b>	252	Bullet Pnsl WS CD/FD
<b>UEC3228L</b>	249	U Ext Corner Wksf	<b>UPBC3048</b>	252	Bullet Pnsl WS CD/FD
<b>UEC3268L</b>	249	U Ext Corner Wksf	<b>UPBC3060</b>	252	U Bullet Penn WS, CD
<b>UEC3280R</b>	249	U Ext Corner Wksf	<b>UPBC3066</b>	252	U Bullet Penn WS, CD
<b>UEC3282R</b>	249	U Ext Corner Wksf	<b>UPBC3072</b>	252	U Bullet Penn WS, CD
<b>UEC3286R</b>	249	U Ext Corner Wksf	<b>UPL</b>	266	U Post Leg
<b>UEC3308L</b>	249	U Ext Corner Wksf	<b>UPL4</b>	266	U Post Leg
<b>UEC3328L</b>	249	U Ext Corner Wksf	<b>UPL4C</b>	266	U Post Leg
<b>UEC3368L</b>	249	U Ext Corner Wksf	<b>UPL4M</b>	266	U Post Leg
<b>UEC3380R</b>	249	U Ext Corner Wksf	<b>UPLC</b>	266	U Post Leg
<b>UEC3382R</b>	249	U Ext Corner Wksf	<b>US1824</b>	221	U Str WS CD
<b>UEC3386R</b>	249	U Ext Corner Wksf	<b>US1830</b>	221	U Str WS CD
<b>UEP24</b>	264	U On-Module End Pnl	<b>US1836</b>	221	U Str WS CD
<b>UEP24S</b>	264	U On-Module End Pnl	<b>US1842</b>	221	U Str WS CD
<b>UEP30</b>	264	U On-Module End Pnl	<b>US1848</b>	221	U Str WS CD
<b>UEP30S</b>	264	U On-Module End Pnl	<b>US1854</b>	221	U Str WS CD
<b>UFSTB</b>	315	Lw Stg-to-Bm Thr Brkt	<b>US1860</b>	221	U Str WS CD
<b>UHDPL</b>	267	U Dbl Post Leg	<b>US1866</b>	221	U Str WS CD
<b>UHPL</b>	266	U Post Leg	<b>US1872</b>	221	U Str WS CD
<b>UJBC2430L</b>	256	U Bubl Jetty WS CD	<b>US1878</b>	221	U Str WS CD
<b>UJBC2430R</b>	256	U Bubl Jetty WS CD	<b>US1884</b>	221	U Str WS CD
<b>UJBC2436L</b>	256	U Bubl Jetty WS CD	<b>US1890</b>	221	U Str WS CD
<b>UJBC2436R</b>	256	U Bubl Jetty WS CD	<b>US1896</b>	221	U Str WS CD
<b>UJBC2442L</b>	256	U Bubl Jetty WS CD	<b>US2424</b>	221	U Str WS CD
<b>UJBC2442R</b>	256	U Bubl Jetty WS CD	<b>US2430</b>	221	U Str WS CD
<b>UJBC2448L</b>	256	U Bubl Jetty WS CD	<b>US2436</b>	221	U Str WS CD
<b>UJBC2448R</b>	256	U Bubl Jetty WS CD	<b>US2442</b>	221	U Str WS CD
<b>UJC2382R</b>	255	U Jetty WS, Fr CD	<b>US2448</b>	221	U Str WS CD
<b>UJC2386R</b>	255	U Jetty WS, Fr CD	<b>US2448S</b>	229	Strgt Wkf w/Sft Eg Prf
<b>UJC2388R</b>	255	U Jetty WS, Fr CD	<b>US2454</b>	221	U Str WS CD

Style Number Index, continued

Style Number	Page	Description
<b>US2454S</b>	229	Strgt Wkf w/Sft Eg Prf
<b>US2460</b>	221	U Str WS CD
<b>US2460S</b>	229	Strgt Wkf w/Sft Eg Prf
<b>US2466</b>	221	U Str WS CD
<b>US2466S</b>	229	Strgt Wkf w/Sft Eg Prf
<b>US2472</b>	221	U Str WS CD
<b>US2472S</b>	229	Strgt Wkf w/Sft Eg Prf
<b>US2478</b>	221	U Str WS CD
<b>US2478S</b>	229	Strgt Wkf w/Sft Eg Prf
<b>US2484</b>	221	U Str WS CD
<b>US2484S</b>	229	Strgt Wkf w/Sft Eg Prf
<b>US2490</b>	221	U Str WS CD
<b>US2490S</b>	229	Strgt Wkf w/Sft Eg Prf
<b>US2496</b>	221	U Str WS CD
<b>US2496S</b>	229	Strgt Wkf w/Sft Eg Prf
<b>US3024</b>	222	U Str WS CD
<b>US3030</b>	222	U Str WS CD
<b>US3036</b>	222	U Str WS CD
<b>US3042</b>	222	U Str WS CD
<b>US3048</b>	222	U Str WS CD
<b>US3048S</b>	229	Strgt Wkf w/Sft Eg Prf
<b>US3054</b>	222	U Str WS CD
<b>US3054S</b>	229	Strgt Wkf w/Sft Eg Prf
<b>US3060</b>	222	U Str WS CD
<b>US3060S</b>	229	Strgt Wkf w/Sft Eg Prf
<b>US3066</b>	222	U Str WS CD
<b>US3066S</b>	229	Strgt Wkf w/Sft Eg Prf
<b>US3072</b>	222	U Str WS CD
<b>US3072S</b>	229	Strgt Wkf w/Sft Eg Prf
<b>US3660</b>	222	U Str WS CD
<b>US3666</b>	222	U Str WS CD
<b>US3672</b>	222	U Str WS CD
<b>USPC47</b>	251	U Spnr WS CD
<b>USPC59</b>	251	U Spnr WS CD
<b>USSBR</b>	262	U Side Supp Brkt
<b>UST1260</b>	241	U Sgl-Tprd WS CD
<b>UST1272</b>	241	U Sgl-Tprd WS CD
<b>UST2160</b>	241	U Sgl-Tprd WS CD
<b>UST2172</b>	241	U Sgl-Tprd WS CD
<b>UST2360</b>	241	U Sgl-Tprd WS CD
<b>UST2372</b>	241	U Sgl-Tprd WS CD
<b>UST3260</b>	241	U Sgl-Tprd WS CD
<b>UST3272</b>	241	U Sgl-Tprd WS CD
<b>USWS</b>	227	U Str WS PM
<b>USWSK</b>	227	U Str WS PM
<b>USWSS</b>	233	U Str WS PM
<b>USWSSW</b>	227	Strgt Wkf w/Sft Eg PM
<b>USWSSWS</b>	233	Strgt Wkf w/Sft Eg PM
<b>UT1236R</b>	237	U Trans WS CD
<b>UT1242R</b>	237	U Trans WS CD
<b>UT1248R</b>	237	U Trans WS CD
<b>UT1254R</b>	237	U Trans WS CD
<b>UT1260R</b>	237	U Trans WS CD
<b>UT2136L</b>	237	U Trans WS CD
<b>UT2142L</b>	237	U Trans WS CD

Style Number	Page	Description
<b>UT2148L</b>	237	U Trans WS CD
<b>UT2154L</b>	237	U Trans WS CD
<b>UT2160L</b>	237	U Trans WS CD
<b>UT2336R</b>	237	U Trans WS CD
<b>UT2342R</b>	237	U Trans WS CD
<b>UT2348R</b>	237	U Trans WS CD
<b>UT2354R</b>	237	U Trans WS CD
<b>UT2360R</b>	237	U Trans WS CD
<b>UT3236L</b>	237	U Trans WS CD
<b>UT3242L</b>	237	U Trans WS CD
<b>UT3248L</b>	237	U Trans WS CD
<b>UT3254L</b>	237	U Trans WS CD
<b>UT3260L</b>	237	U Trans WS CD
<b>UTT1248</b>	238	U Taprd WS CD
<b>UTT1260</b>	238	U Taprd WS CD
<b>UTT1272</b>	238	U Taprd WS CD
<b>UTT2148</b>	238	U Taprd WS CD
<b>UTT2160</b>	238	U Taprd WS CD
<b>UTT2172</b>	238	U Taprd WS CD
<b>UTT2348</b>	238	U Taprd WS CD
<b>UTT2348S</b>	239	Tprd Wkf w/Sft Eg Prf
<b>UTT2360</b>	238	U Taprd WS CD
<b>UTT2360S</b>	239	Tprd Wkf w/Sft Eg Prf
<b>UTT2372</b>	238	U Taprd WS CD
<b>UTT2372S</b>	239	Tprd Wkf w/Sft Eg Prf
<b>UTT3248</b>	238	U Taprd WS CD
<b>UTT3248S</b>	239	Tprd Wkf w/Sft Eg Prf
<b>UTT3260</b>	238	U Taprd WS CD
<b>UTT3260S</b>	239	Tprd Wkf w/Sft Eg Prf
<b>UTT3272</b>	238	U Taprd WS CD
<b>UTT3272S</b>	239	Tprd Wkf w/Sft Eg Prf
<b>UTTF1260</b>	240	U Taper-Flat WS CD
<b>UTTF1272</b>	240	U Taper-Flat WS CD
<b>UTTF1360</b>	240	U Taper-Flat WS CD
<b>UTTF1372</b>	240	U Taper-Flat WS CD
<b>UTTF2160</b>	240	U Taper-Flat WS CD
<b>UTTF2172</b>	240	U Taper-Flat WS CD
<b>UTTF2360</b>	240	U Taper-Flat WS CD
<b>UTTF2372</b>	240	U Taper-Flat WS CD
<b>UTTF3160</b>	240	U Taper-Flat WS CD
<b>UTTF3172</b>	240	U Taper-Flat WS CD
<b>UTTF3260</b>	240	U Taper-Flat WS CD
<b>UTTF3272</b>	240	U Taper-Flat WS CD
<b>UTTRC</b>	260	Cord and Plug
<b>UTTRCN</b>	260	Cord and Plug
<b>UVC2424L</b>	258	U Visitor Wksf
<b>UVC2424R</b>	259	U Visitor Wksf
<b>UVC2430L</b>	258	U Visitor Wksf
<b>UVC2430R</b>	259	U Visitor Wksf
<b>UVC2436L</b>	258	U Visitor Wksf
<b>UVC2436R</b>	259	U Visitor Wksf
<b>UVC2442L</b>	258	U Visitor Wksf
<b>UVC2442R</b>	259	U Visitor Wksf
<b>UVC2448L</b>	258	U Visitor Wksf
<b>UVC2448R</b>	259	U Visitor Wksf

Style Number	Page	Description	Style Number	Page	Description
<b>UVC3030L</b>	258	U Visitor Wksf	<b>WEC336048</b>	249	U Ext Corner Wksf
<b>UVC3030R</b>	259	U Visitor Wksf	<b>WEC337242</b>	249	U Ext Corner Wksf
<b>UVC3036L</b>	259	U Visitor Wksf	<b>WEC337248</b>	249	U Ext Corner Wksf
<b>UVC3036R</b>	259	U Visitor Wksf	<b>WJ234866R</b>	255	Jetty Worksurface FD
<b>UVC3042L</b>	259	U Visitor Wksf	<b>WJ234872R</b>	255	Jetty Worksurface FD
<b>UVC3042R</b>	259	U Visitor Wksf	<b>WJ234878R</b>	255	Jetty Worksurface FD
<b>UVC3048L</b>	259	U Visitor Wksf	<b>WJ326648L</b>	255	Jetty Worksurface FD
<b>UVC3048R</b>	259	U Visitor Wksf	<b>WJ327248L</b>	255	Jetty Worksurface FD
<b>WCC113636</b>	245	U Corner Wksf	<b>WJ327848L</b>	255	Jetty Worksurface FD
<b>WCC114242</b>	245	U Corner Wksf	<b>WJ334866R</b>	255	Jetty Worksurface FD
<b>WCC114848</b>	245	U Corner Wksf	<b>WJ334872R</b>	255	Jetty Worksurface FD
<b>WCC124242</b>	245	U Corner Wksf	<b>WJ334878R</b>	255	Jetty Worksurface FD
<b>WCC214242</b>	245	U Corner Wksf	<b>WJ336648L</b>	255	Jetty Worksurface FD
<b>WCC223636</b>	245	U Corner Wksf	<b>WJ337248L</b>	255	Jetty Worksurface FD
<b>WCC224242</b>	245	U Corner Wksf	<b>WJ337848L</b>	255	Jetty Worksurface FD
<b>WCC224848</b>	245	U Corner Wksf	<b>WPA2448</b>	253	U Angled Pnsl WS FD
<b>WCC334242</b>	245	U Corner Wksf	<b>WPA2460</b>	253	U Angled Pnsl WS FD
<b>WCC334848</b>	245	U Corner Wksf	<b>WPA3048</b>	253	U Angled Pnsl WS FD
<b>WCF223636</b>	242	U CNR, Flat-Fr WS FD	<b>WPA3060</b>	253	U Angled Pnsl WS FD
<b>WCF224242</b>	242	U CNR, Flat-Fr WS FD	<b>WS1824</b>	221	U Str WS FD
<b>WCF224848</b>	242	U CNR, Flat-Fr WS FD	<b>WS1830</b>	221	U Str WS FD
<b>WCF334242</b>	242	U CNR, Flat-Fr WS FD	<b>WS1836</b>	221	U Str WS FD
<b>WCF334848</b>	242	U CNR, Flat-Fr WS FD	<b>WS1842</b>	221	U Str WS FD
<b>WDC224242</b>	243	U Dual Corner Wksf	<b>WS1848</b>	221	U Str WS FD
<b>WDC224848</b>	243	U Dual Corner Wksf	<b>WS1854</b>	221	U Str WS FD
<b>WDC334848</b>	243	U Dual Corner Wksf	<b>WS1860</b>	221	U Str WS FD
<b>WEC224260</b>	249	U Ext Corner Wksf	<b>WS1866</b>	221	U Str WS FD
<b>WEC224272</b>	249	U Ext Corner Wksf	<b>WS1872</b>	221	U Str WS FD
<b>WEC224860</b>	249	U Ext Corner Wksf	<b>WS1878</b>	221	U Str WS FD
<b>WEC224872</b>	249	U Ext Corner Wksf	<b>WS1884</b>	221	U Str WS FD
<b>WEC226042</b>	249	U Ext Corner Wksf	<b>WS1890</b>	221	U Str WS FD
<b>WEC226048</b>	249	U Ext Corner Wksf	<b>WS1896</b>	221	U Str WS FD
<b>WEC227242</b>	249	U Ext Corner Wksf	<b>WS2424</b>	221	U Str WS FD
<b>WEC227248</b>	249	U Ext Corner Wksf	<b>WS2430</b>	221	U Str WS FD
<b>WEC234260</b>	249	U Ext Corner Wksf	<b>WS2436</b>	221	U Str WS FD
<b>WEC234272</b>	249	U Ext Corner Wksf	<b>WS2442</b>	221	U Str WS FD
<b>WEC234860</b>	249	U Ext Corner Wksf	<b>WS2448</b>	221	U Str WS FD
<b>WEC234872</b>	249	U Ext Corner Wksf	<b>WS2448S</b>	229	Strgt Wkf w/Sft Eg Prf
<b>WEC236042</b>	249	U Ext Corner Wksf	<b>WS2454</b>	221	U Str WS FD
<b>WEC236048</b>	249	U Ext Corner Wksf	<b>WS2454S</b>	229	Strgt Wkf w/Sft Eg Prf
<b>WEC237242</b>	249	U Ext Corner Wksf	<b>WS2460</b>	221	U Str WS FD
<b>WEC237248</b>	249	U Ext Corner Wksf	<b>WS2460S</b>	229	Strgt Wkf w/Sft Eg Prf
<b>WEC324260</b>	249	U Ext Corner Wksf	<b>WS2466</b>	221	U Str WS FD
<b>WEC324272</b>	249	U Ext Corner Wksf	<b>WS2466S</b>	229	Strgt Wkf w/Sft Eg Prf
<b>WEC324860</b>	249	U Ext Corner Wksf	<b>WS2472</b>	221	U Str WS FD
<b>WEC324872</b>	249	U Ext Corner Wksf	<b>WS2472S</b>	229	Strgt Wkf w/Sft Eg Prf
<b>WEC326042</b>	249	U Ext Corner Wksf	<b>WS2478</b>	221	U Str WS FD
<b>WEC326048</b>	249	U Ext Corner Wksf	<b>WS2478S</b>	229	Strgt Wkf w/Sft Eg Prf
<b>WEC327242</b>	249	U Ext Corner Wksf	<b>WS2484</b>	221	U Str WS FD
<b>WEC327248</b>	249	U Ext Corner Wksf	<b>WS2484S</b>	229	Strgt Wkf w/Sft Eg Prf
<b>WEC334260</b>	249	U Ext Corner Wksf	<b>WS2490</b>	221	U Str WS FD
<b>WEC334272</b>	249	U Ext Corner Wksf	<b>WS2490S</b>	229	Strgt Wkf w/Sft Eg Prf
<b>WEC334860</b>	249	U Ext Corner Wksf	<b>WS2496</b>	221	U Str WS FD
<b>WEC334872</b>	249	U Ext Corner Wksf	<b>WS2496S</b>	229	Strgt Wkf w/Sft Eg Prf
<b>WEC336042</b>	249	U Ext Corner Wksf	<b>WS3024</b>	222	U Str WS FD

Style Number Index, continued

Style Number	Page	Description
<b>WS3030</b>	222	U Str WS FD
<b>WS3036</b>	222	U Str WS FD
<b>WS3042</b>	222	U Str WS FD
<b>WS3048</b>	222	U Str WS FD
<b>WS3048S</b>	229	Strgt Wkf w/Sft Eg Prf
<b>WS3054</b>	222	U Str WS FD
<b>WS3054S</b>	229	Strgt Wkf w/Sft Eg Prf
<b>WS3060</b>	222	U Str WS FD
<b>WS3060S</b>	229	Strgt Wkf w/Sft Eg Prf
<b>WS3066</b>	222	U Str WS FD
<b>WS3066S</b>	229	Strgt Wkf w/Sft Eg Prf
<b>WS3072</b>	222	U Str WS FD
<b>WS3072S</b>	229	Strgt Wkf w/Sft Eg Prf
<b>WSPC4824</b>	251	U Spnr WS FD
<b>WSPC6030</b>	251	U Spnr WS FD
<b>WST1260</b>	241	U Sgl-Taprd WS FD
<b>WST1272</b>	241	U Sgl-Taprd WS FD
<b>WST2160</b>	241	U Sgl-Taprd WS FD
<b>WST2172</b>	241	U Sgl-Taprd WS FD
<b>WST2360</b>	241	U Sgl-Taprd WS FD
<b>WST2372</b>	241	U Sgl-Taprd WS FD
<b>WST3260</b>	241	U Sgl-Taprd WS FD
<b>WST3272</b>	241	U Sgl-Taprd WS FD
<b>WT2336</b>	237	U Trans WS FD
<b>WT2342</b>	237	U Trans WS—FD0
<b>WT2348</b>	237	U Trans WS—FD
<b>WT2354</b>	237	U Trans WS—FD
<b>WT2360</b>	237	U Trans WS—FD
<b>WT3236</b>	237	U Trans WS—FD
<b>WT3242</b>	237	U Trans WS—FD
<b>WT3248</b>	237	U Trans WS—FD
<b>WT3254</b>	237	U Trans WS—FD
<b>WT3260</b>	237	U Trans WS—FD
<b>WTT1248</b>	238	U Sgl-Taprd WS FD
<b>WTT1260</b>	238	U Sgl-Taprd WS FD
<b>WTT1272</b>	238	U Sgl-Taprd WS FD
<b>WTT2148</b>	238	U Sgl-Taprd WS FD
<b>WTT2160</b>	238	U Sgl-Taprd WS FD
<b>WTT2172</b>	238	U Sgl-Taprd WS FD
<b>WTT2348</b>	238	U Sgl-Taprd WS FD
<b>WTT2348S</b>	239	Tprd Wkf w/Sft Eg Prf
<b>WTT2360</b>	238	U Sgl-Taprd WS FD
<b>WTT2360S</b>	239	Tprd Wkf w/Sft Eg Prf
<b>WTT2372</b>	238	U Sgl-Taprd WS FD
<b>WTT2372S</b>	239	Tprd Wkf w/Sft Eg Prf
<b>WTT3248</b>	238	U Sgl-Taprd WS FD
<b>WTT3248S</b>	239	Tprd Wkf w/Sft Eg Prf
<b>WTT3260</b>	238	U Sgl-Taprd WS FD
<b>WTT3260S</b>	239	Tprd Wkf w/Sft Eg Prf
<b>WTT3272</b>	238	U Sgl-Taprd WS FD
<b>WTT3272S</b>	239	Tprd Wkf w/Sft Eg Prf
<b>WTTF1260</b>	240	U Taper-Flat WS—FD
<b>WTTF1272</b>	240	U Taper-Flat WS—FD
<b>WTTF1360</b>	240	U Taper-Flat WS—FD
<b>WTTF1372</b>	240	U Taper-Flat WS—FD

Style Number	Page	Description
<b>WTTF2160</b>	240	U Taper-Flat WS—FD
<b>WTTF2172</b>	240	U Taper-Flat WS—FD
<b>WTTF2360</b>	240	U Taper-Flat WS—FD
<b>WTTF2372</b>	240	U Taper-Flat WS—FD
<b>WTTF3160</b>	240	U Taper-Flat WS—FD
<b>WTTF3172</b>	240	U Taper-Flat WS—FD
<b>WTTF3260</b>	240	U Taper-Flat WS—FD
<b>WTTF3272</b>	240	U Taper-Flat WS—FD
<b>WVC2424L</b>	258	U Visitor Wksf
<b>WVC2424R</b>	259	U Visitor Wksf
<b>WVC2430L</b>	258	U Visitor Wksf
<b>WVC2430R</b>	259	U Visitor Wksf
<b>WVC3030L</b>	258	U Visitor Wksf
<b>WVC3030R</b>	259	U Visitor Wksf



# Trademark List

- ® The following are registered trademarks for products of Steelcase Inc. or one of its related corporate entities: 4 o'clock, 900 Series, à la carte, Airtouch, Ally, Amia, Answer, Archipelago, Avenir, Ballet, Bix, Brayton International, Cachet, Canopy, Canto, Chancellor, Coalesse, Confidante, Context, Convene, CopyCam, Criterion, Crushed Can, Currency, dash, Designtex, Details, Detour, Drive, Elective Elements, Ellipse, Ember Chrome, Emerge, E-Table 2, FYI, Garland, Gentry, Ginkgo Biloba, Groupwork, Ideo, Jacket, Jenny, Jersey, Kart, Kick, LaCosta, Leap, LessThanFive, Let's B, LiveBack, Max-Stacker, media:scape, Metro, Migrations, Mitra, Montage, Nurture, Oriana, Parade, Pathways, PCT, Permiso, Player, Portal, Power Pincher, Progeny, Protégé, R2, Rally, Relevant, Reply, Rizzi Arc, Sensor, Series 9000, Siento, Sieste, Sine, Softcare, Springboard, Steelcase, Steelcase Design Partnership, Stella, Stow Davis, Swathmore, Sylvi, TeamWork, Technique, Texpress, Think, Thunder, Topo, Train, turnstone, Underline, Unison, Vecta, Viridian, Walden, Wernld, and X-Stack.
- ® The following registered trademarks are under license from AWI Licensing Company, Dover, DE: SoundScapes, DuraBrite, BioBlock, and Armstrong.
- ® The following registered trademarks are under license from Byrne Electrical, Rockford, MI: Interport, Mini-Port, Axil Z, and Ellora.
- ® The following is a registered trademark of DuPont, Wilmington, DE: Corian.
- ® The following is a registered trademark of Genlyte Thomas Company, Louisville, KY: Lightlior.
- ® The following is a registered trademark of Hilti Corporation, FL-9494 Schaan, Principality of Liechtenstein: Hilti.
- ® The following is a registered trademark of Leviton Manufacturing Company, Little Neck, NY: Decora.
- ® The following is a registered trademark of Mechanical Plastics Corp, Elmsford, NY: Toggler.
- ® The following is a registered trademark of Microsoft Corporation, Redmond, WA: Microsoft.
- ® The following are registered trademarks of Orangebox Ltd., Cardiff, UK: Orangebox.
- ® The following is a registered trademark of Panduit Corporation, Lockport, IL: Panduit.
- ® The following is a registered trademark of Trav (Press), Cuneo, Italy: Assisa.
- ® The following is a registered trademark of Virtual Ink, Boston, MA: mimioActive.
- ® The following registered trademarks are under license from Wilkhahn Furniture Products: Avera, Senzo, Versal, and Wilkhahn FS.
- ® The following are registered trademarks of Polyvision Corp: Flow, Motif, Polyvision, Sans, and Serif.
- ® The following is a registered trademark of Wilsonart International, Temple, TX: Chemsurf.
- ® The following is a registered trademark of Wiremold, West Hartford, CT: Wiremold.
- ® The following is a registered trademark of EMU Group S.P.A., Perugia, Italy: EMU.
- ® The following is a registered trademark of Security People, Inc.: Digilock.
- ® The following are registered trademarks of Natural Capital Partners Europe Limited: CarbonNeutral and the CarbonNeutral Certified logo.
- ™ The following are trademarks for products of Steelcase Inc. or one of its related corporate entities: Access, Active/Passive Shelf, Agree, Ainsley, Akira, Alcove, Alerion, Alight, Amaris, American Elect, American Tradition, ap40, Arbor, Arriva, Asana, Ascot, Aspekt, Astor, Await, Bassline, B-Free, Bira, Bivi, Bixby, Bottomline, Brody, Brook, Buoy, Burton, c:scape, Calla, Calm, Camber, Campfire, Capa, Cappuccino, Cesar, Chester, Chord, Circa, Clarendon, Classic Rectangular, Clipper, cobl, Collaboration, Community, Company, Convey, Cortex, Coupe, Crea, Crew, Cura, Cypress, Davenport, Dearborn, Deck, Déjà, Denizen, Denska, Derby, DeskWizard, Divisio, Donovan, Dune, Duo, Echo, Edge, Elbrook, Elsa, Empath, Empress, Enea, ño, EnSync, Enviro, Escapade, Everwall, Exchange, Exponents, Field, Flat Top, FlexFrame, Flip Top, Flute, Folio, FrameOne, FreeFlow, Frontier, Galilei, Gesture, Ginger, Ginkgo, Go Wall, Grip, Groove, Hatchback, Hawthorne, Hitch, Host Collection, Hosu, Huddleboard, i2i, Impact, Indy, InfoLink, IOS, I-Solve, Jack, Jarrah, Jetty, Juice, Kami, Kast, Kathryn, Lagunitas, Lark, L'Attitude, LearnLab, Leela, Lincoln, Linden, LiveSeat, Loria, Lyric, Malibu, Malibu Too, Mansfield, Marathon, Marien152, Martini, Mason, Masque, Migration, Millbrae, Mineral, Mingle, Mystic, Mystic Metal, Mystic Wood, Montara650, Montreal, MoreThanFive, Move, Nadia, Neighbor, nesso, Nickel, Nikko, Nod, Node, Norfolk, Ocular, Ology, Ontrak, Oom, Opus, Orchid, Outlook Collection, Ovation, Paloma, Paperflo, Parliament, Pasio, Passerelle, Patriarch, Payback, Peek, Pile File, Pisa, Pool, Potrero415, PUCK, QiVi, Quba, Radia, Rave, Reed, Regard, Relay, Reunion, Ripple, Riser, Roam, Rocco, Rocky, RoomWizard, Runner, Satellite, Sawyer, ScapeSeries, Senti, Sentinel, Senza, Sequoia, Session, ShareLink, Shield, Shortcut, Sidewalk, SILQ, Skylar, Slumber, Smoke, Snug, Soft Leaf, Sonata, Sorrel, SOTO, Southside, Stationkits, Steelcase Karman, Steelcase Series, Stiletto, Surprise!, Surround, Switch, Symphony, Sync, TagWizard, Tava, TeamStudio, TeamTheater, Tenaro, Tenor, Terrazzo, Theorem, Thread, Topaz, Touchdown, Tour, Tower Too, Trees, Trillium, Trolley, tX2, U-Free, Umami, Underscore, Uno, V.I.A., Verb, Verge, Verlay, Victor2, Visalia, Waldorf, Woodruff, Workspring, WorkValet and X-tenz.
- ™ The following is a trademark of Microsoft Corporation, Redmond, WA: Windows.
- ™ The following is a trademark of Rodman Industries, Inc., Oconomowoc, WI: ResinCore1.
- ™ The following is a trademark of Ultrafabrics, LLC, Elmsford, NY: Ultraleather.
- ™ The following trademarks are under license from Wilkhahn Furniture products: Cana, Linus, Logon, Picto, Range, Stitz, Thema, Timetable, and Tubis.
- ™ The following is a trademark of Cradle to Cradle Products Innovation Institute, Oakland, CA: Cradle to Cradle Certified.
- ™ The following trademarks are under license from Walter Knoll: Andoo, Bob, Lazlo, Lox, Ribbon, and Together.
- ™ The following trademarks are under license from PP Møbler: Bar and Flag Halyard.
- ™ The following trademarks are under license from Carl Hansen: Elbow, Paddle, Shell, Wing, and Wishbone.
- ™ The following trademarks are under license from Cambridge Sound Management, LLC, Cambridge, MA: QtPro Soundmasking, Qt Quiet Technology, and Sonet Qt.
- ™ The following is a trademark of Electri-Cable Assemblies, Shelton, CT: Interact.
- ™ The following is a trademark of Clestra Hauserman: IRYS.
- ™ The following is a trademark of Wiesner-Hager Möbel GmbH: Nooi.
- ™ The following are trademarks of Polyvision: Accord, a<sup>3</sup>, e<sup>3</sup>, Boundri, and Nota.
- ™ The following is a trademark of Bostock Company, Inc: SnapCab.
- ™ The following is a trademark of Williams-Sonoma, Inc: West Elm.
- ™ The following is a trademark of Elena Marquina Testor: nanimarquina.
- ™ The following is a trademark of Forbo International SA: Forbo.
- ™ The following are trademarks of Orangebox Ltd., Cardiff, UK: Air<sup>3</sup>, Aspect, Avi, Away from the Desk, Border, Campers & Dens, Coppice, Cubb, Kirm, On the QT, Ramsey, Skoner, Sully, Track-B, and Vale.
- ™® The following are trademarks or registered trademarks of AMQ Solutions, LLC: AMQ, AMQ logo, KINEX, ILINE, ACTIV, AMOBI, CONCUR, 3F, REVI, S-SERIES, JAKU, SIYA, ZILO, BODI, FL-X, TIZU, EMBANK, TEKTIS and BIXBY.
- ™® The following are trademarks or registered trademarks of Viccarbe Habitat, S.L.: Holy Day, Last Minute, Wrapp, Foro, Kelly, Noha, Viable, Solar, Sistema, Savina, Designed In The Sun, Cambio, Aleta, Viccarbe (logo), Viccarbe.

*Trademarks used here in are the property of Steelcase Inc. or of their respective owners.*