

technical furniture

Universally Adjustable VDT Stand

Tools Required

- 4mm Allen wrench (provided)
- 5mm Allen wrench (provided)
- 6mm Allen Wrench (provided)
- Phillips head screwdriver

1. Attach the **Feet** to the adjustable **Base Frame** using the M8 x 1.00"(25mm) Socket head screws and lock washers. Tighten securely using the 6mm wrench. Install the round and square **End Caps** on the Feet. See **Figure 1**.

NOTE: Install the Feet with the longer portion to the rear of the unit.

2. Assemble the left and right hand **Top Supports** to the Base Frame using the M8 x .64"(16mm) Socket flat head cap screws. Tighten securely using the 5mm wrench. See **Figure 1**.

3. Place the **Rear Surface** (keyboard and monitor laminate tops are packaged separately) onto the rear Top Supports. Align the holes in one of the **Surface Mount** with the holes in the bottom of the Rear Surface. Note that the Top Supports are sandwiched between the Rear Surface and the Surface Mounts.

Attach the Surface Mounts to the Rear Surface using the #8 x 1.25"(30mm) screws provided. Repeat this procedure for the **Front Surface**. See **Figure 2**.

NOTE: The radiused side of both Surfaces face towards the front of the unit.

4. The **Front Crank Assembly** may be installed on the left or right side of the unit. Fasten the **Mounting Block** to the appropriate Top Support using the two M-5 x .38"(10mm) Socket head screws provided. Tighten securely using the 4mm wrench. See **Figure 2**.

Insert the Front Crank Assembly through the Mounting Block and onto the **Drive Pin** located on the Base Frame. Fasten the Crank Assembly to the Drive Pin with the **Connector Clip**. See **Figure 2**.

5. Install the removable **Rear Crank** into the Rear Surface drive mechanism on either side of the Surface. The holes in the Surface must be aligned with the drive mechanism on the Base Frame. See **Figure 2**.

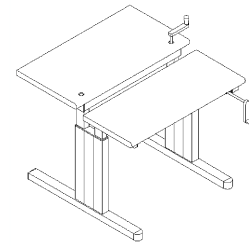

Universally Adjustable VDT Stand

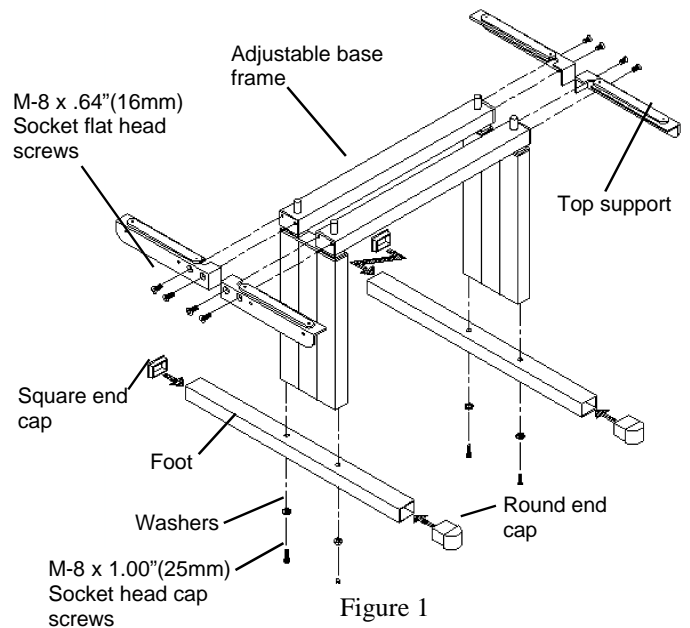

Figure 1

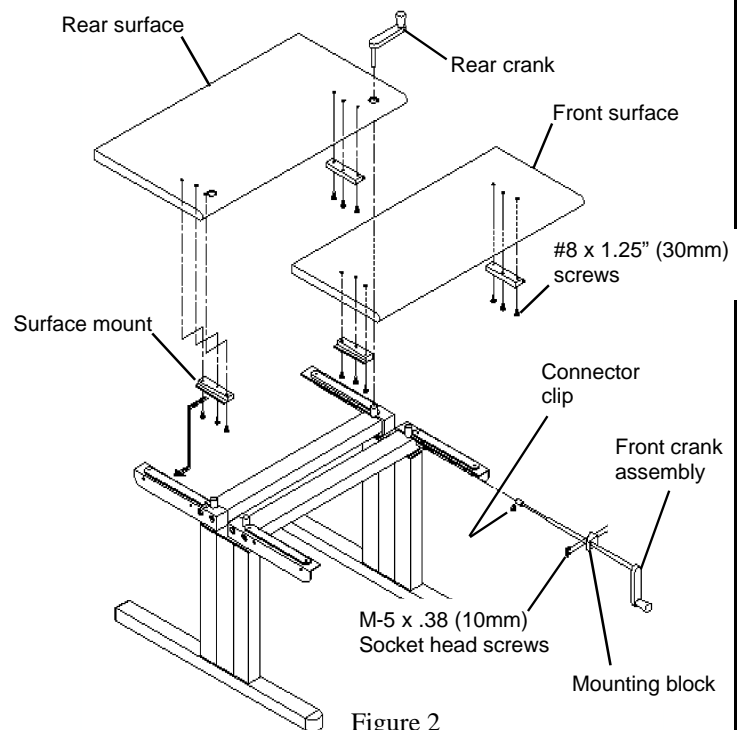

Figure 2

Worksurface Side Extension

Tools Required

- 5mm Allen wrench (provided)
- Phillips head screw driver

Parts List

- (1) #5377X - Top
- (1) #2519X - Support
- (1) #59103 - #10AB x 3/4" Phillips head screw
- (6) #81718 - M-8 x 16mm Flat socket head cap

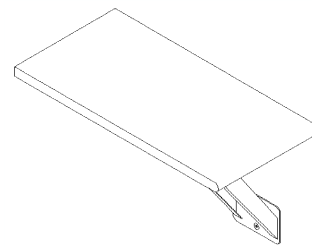

Worksurface Side Extension

NOTE: The **Side Extension** may be installed on the left or right hand side of a 30" wide Universally Adjustable VDT stand only. It cannot be installed on a Workstation with 36" or 42" wide surfaces.

With two Side Extensions installed on a 30" wide unit, the overall width of the Workstation is 60".

1. Attach the Side Extension **Support** to the Adjustable Base Frame using the two M-8 x 16mm Flat socket head cap screws. Tighten securely with the 5mm Allen wrench. See **Figure 1**.
2. Place the Side Extension **Top** onto the Side Extension Support and line up the holes in the Top with the holes in the Side Extension Support. Fasten in place with the four #10AB x 3/4" Phillips head screws provided. See **Figure 1**.

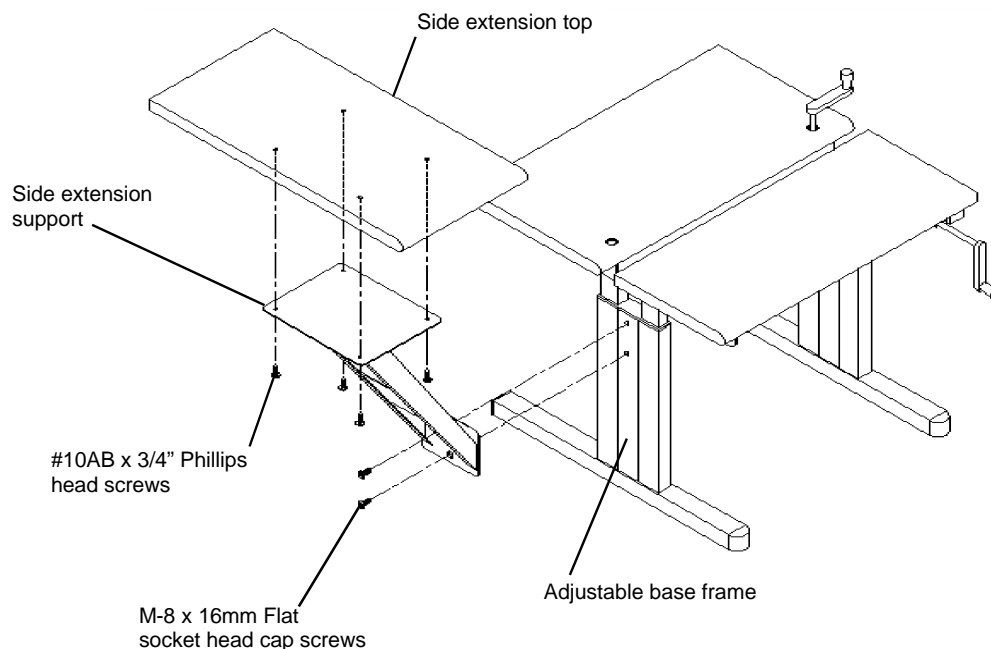
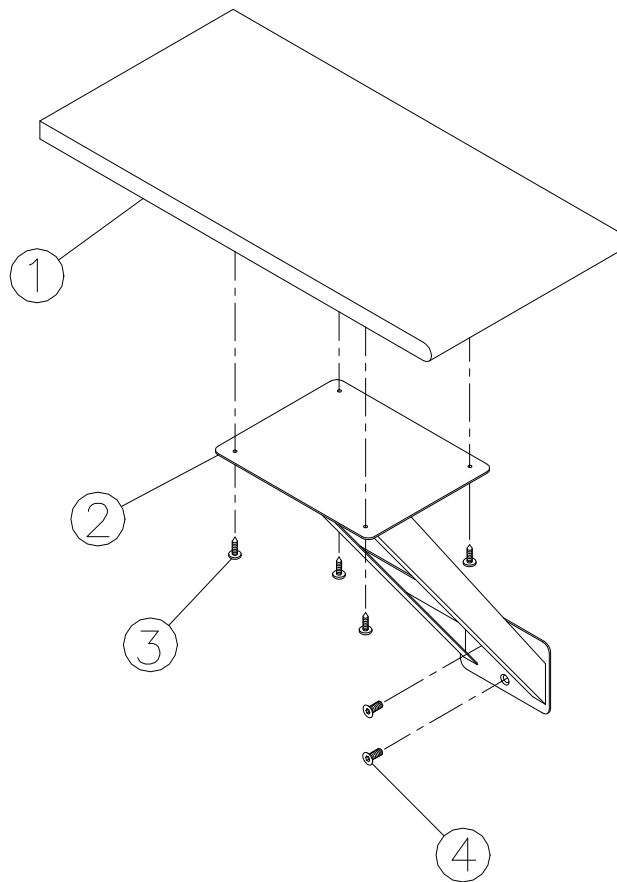

Figure 1

Work surface Side Extension (cont.)

Parts List			
Part Number		Description	Qty.
1	5377X	Top	1
2	2519X	Support Side Extension	1
3	59103	#10AB x .75" Phillips Pan Head Thread Forming Screw	4
4	81718	M8 x 12mm Flat Head Socket Cap Screw	2



Height Adjustable Worksurface

Tools Required

- Phillips head screwdriver
- 6mm Allen wrench (provided)

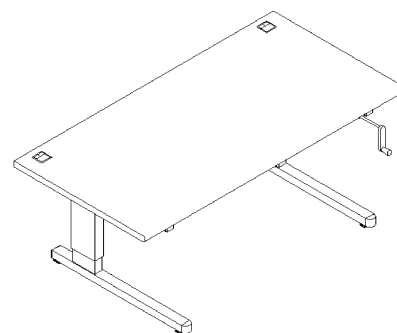

Height Adjustable Worksurface

1. Attach the **Feet** to the adjustable **Base Frame** using the M-8 x 1.00" Socket head screws and Lock washers. Tighten securely using the 6mm Allen wrench. Install the round and square **End Caps** on the Feet. See **Figure 1**.

NOTE: Install the Feet with the longer portion to the front of the unit.

2. Install the left and right hand **Top Supports** using the four M-8 x 2.25" Socket head screws and 1.00" **Spacers**. Tighten securely with the 6mm Allen wrench. Install the square **End Caps** at both ends of the Supports. Install the round **Hole Plugs**. See **Figure 2**.

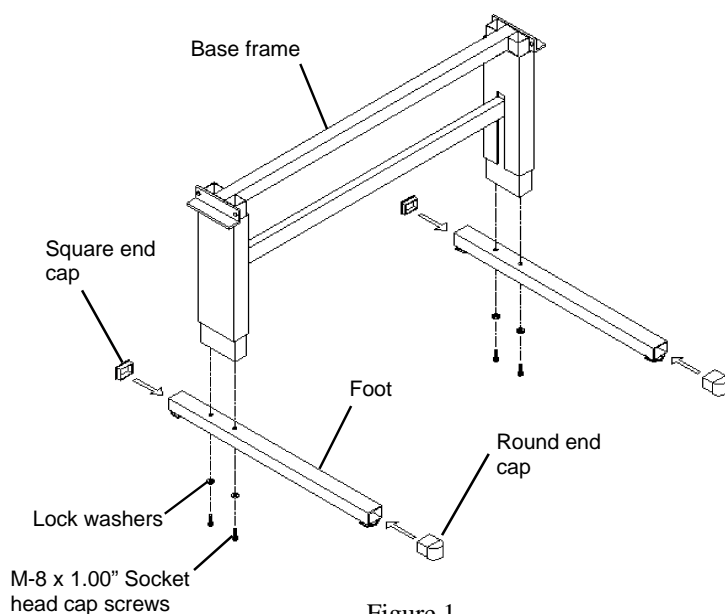

Figure 1

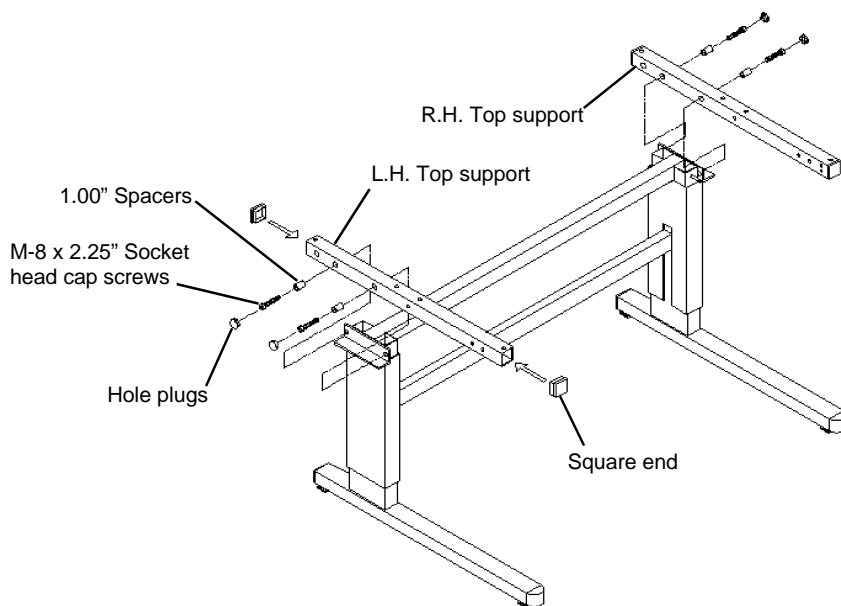

Figure 2

3. The **Front Crank Assembly** may be installed on either the right or left side. Fasten the **Mounting Block** to the appropriate **Support** using the two **#10 x 1/2"** Pan head screws. Tighten securely. See **Figure 3a**.

Insert the Crank Assembly through the Mounting Block and onto the drive pin in the Base Frame. Fasten the Crank Assembly to the drive pin using the **Connector Clip**. See **Figure 3b**.

4. Place the **Worksurface** on the Top Supports. Align the holes in the Supports with the holes in the bottom of the Surface. Attach the Surface to the Supports using the eight **#8 x 2.25"** screws provided. See **Figure 4**.

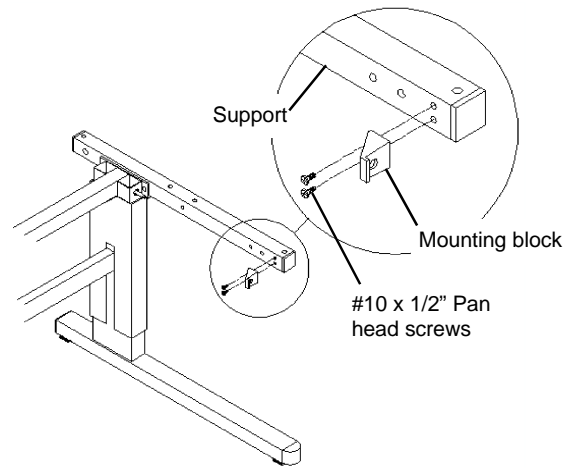

Figure 3a

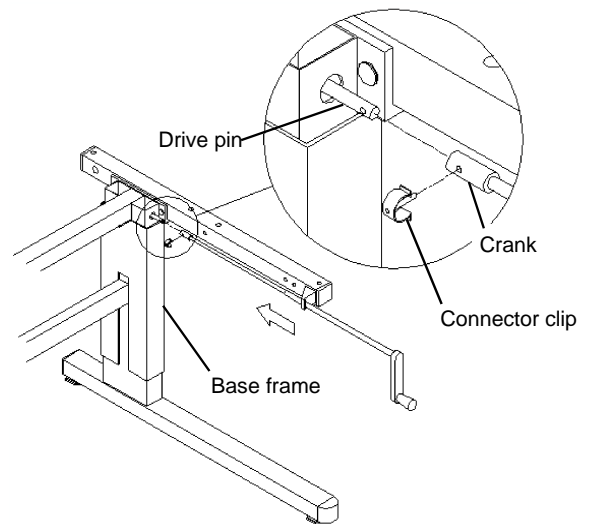

Figure 3b

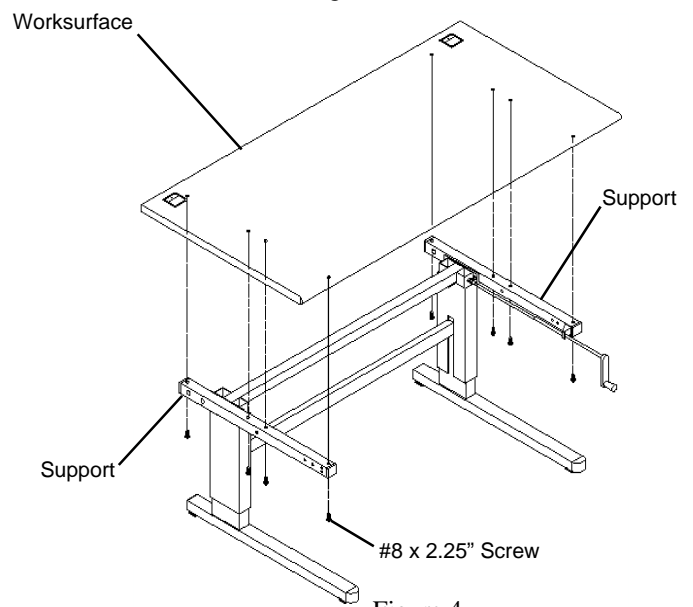

Figure 4

technical furniture

Height Adjustable Service Parts List

Parts List			
Part Number		Description	Qty.
1	1934X/1933X	Base Frame	1
2	82741	Top Support, L.H.	1
3	82740	Top Support, R.H.	1
4	2518X	Crank Assembly, Front	1
5	81717	Mounting Bracket w/(2) #10 x 1/2" Pan Head Screws	1
6	63526	Name Plate (provided by Wright Line)	1
7	82739	Square End Cap, Black	4
8	81716	Connector Clip	1
9	81721	M-8 x 1.00"(25mm) Socket Head Cap Screw	4
10	18950	Lock Washer	4
11	82737	M-8 x 2.1" Socket Head Cap Screw	4
12	82738	Spacer	4
13	82742	Round Hole Plug	4
14	59844	#8 x 2.25" Screw	8
15	1937X/1938X	60" or 48" Top	1
	2150X/2151X		
16	1243X	Foot	2
17	1242X	End Caps (pair)	2
18	2514X	Base Frame	
19	5374X	Top, 30" x 16"	1
	5375X	Top, 36" x 16"	
	5376X	Top, 42" x 16"	
20	5371X	Top, 30" x 13"	1
	5372X	Top, 36" x 13"	
	5373X	Top, 42" x 13"	

technical furniture

Height Adjustable Worksurfaces

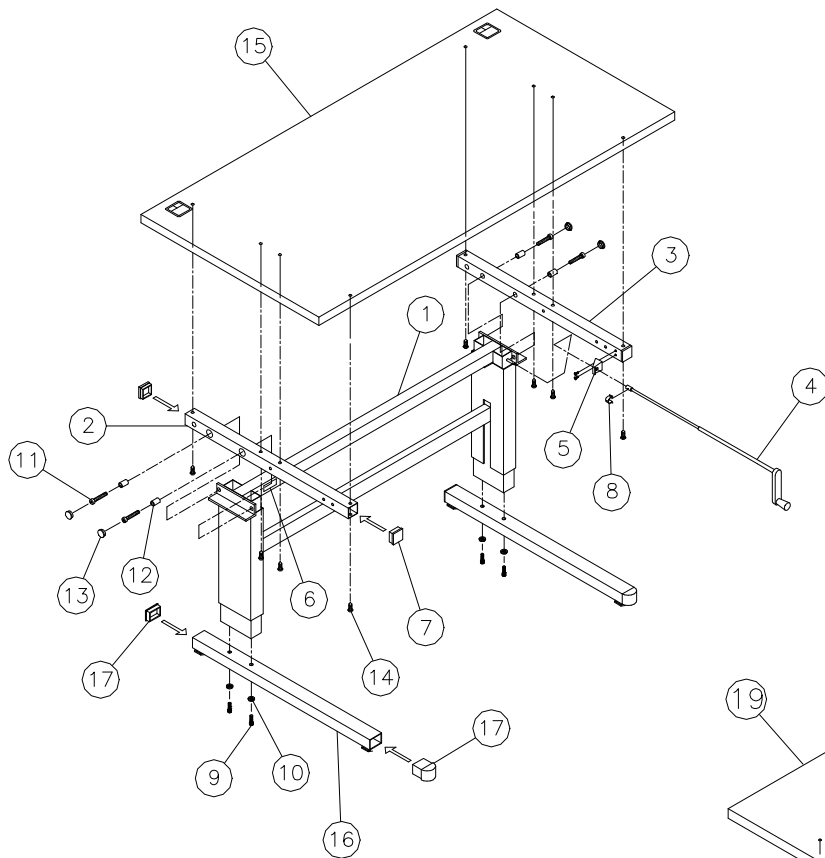

Height Adjustable Worksurface

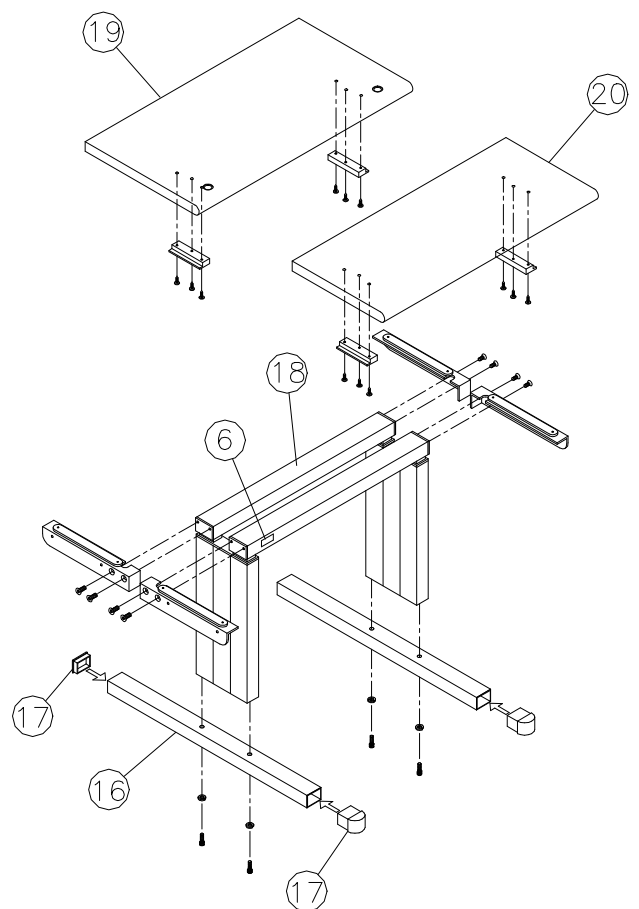

Universally Adjustable VDT Stand

technical furniture

Mobile Pedestal

Tools Required
-None

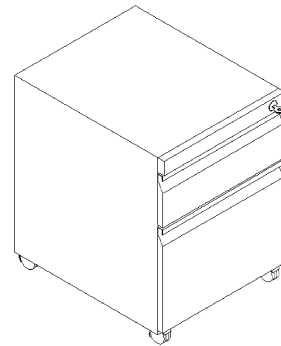

Mobile Pedestal
#C843, #C845, #C846

CASTER INSTALLATION

1. Carefully lay the **Mobile Pedestal** on its back. Install a **Caster** at each corner of the bottom by inserting the Caster stems into the holes. Push the Casters in until they are fully seated. See **Figure 1**.

IMPORTANT: Install the **Locking Casters** at the front as shown.

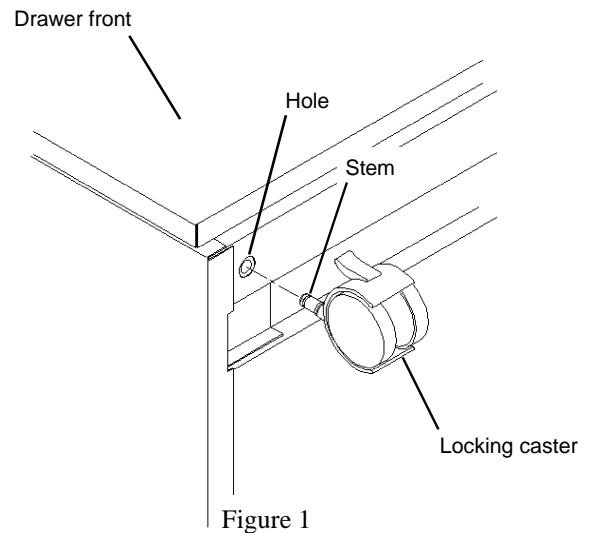

Filing Methods

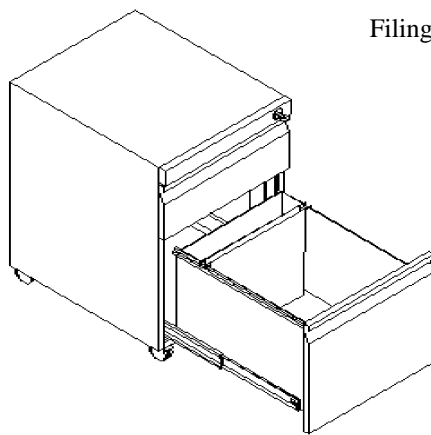

Front-Back Filing

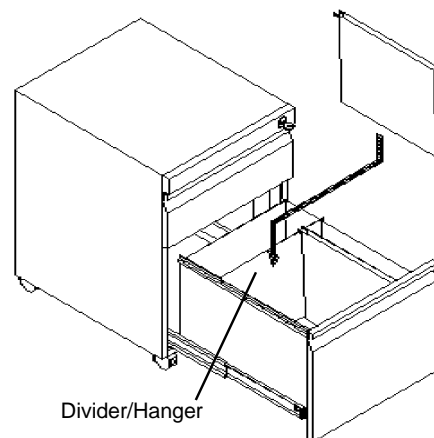

Divider/Hanger

Lateral Filing

Tools Required

- Phillips head screwdriver
- 5/32" Allen wrench (provided)
- Electric drill
- 1/8" Drill bit
- Drill template (provided)

IMPORTANT: It is recommended that the assembly of this product be done on the floor. Assistance may be required.

ASSEMBLING THE ORGANIZER

1. Carefully slide the **Uprights** over the ends of the **Back Panel**. Be sure that the holes for Mounting Brackets are at the bottom of the Uprights. See **Figure 1**.
2. Install the 1/4"-20 x 2-1/2" Button head cap screws through the Uprights and through the Back Panel. Thread the screws in until their heads touch the Uprights (snug fit). **DO NOT TIGHTEN**. See **Figure 1**.

If a second Back Panel is to be installed, slide it down from the top and install the screws. **DO NOT TIGHTEN**.

See **Figure 2**.

3. Make sure that the bottom of the Back Panel and Uprights are flush. Starting at the bottom, tighten each screw 1/4 turn from the snug position. **DO NOT OVER TIGHTEN**.

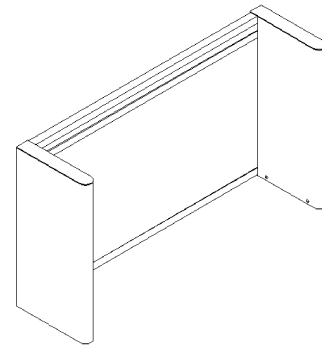

Workstation Organizers

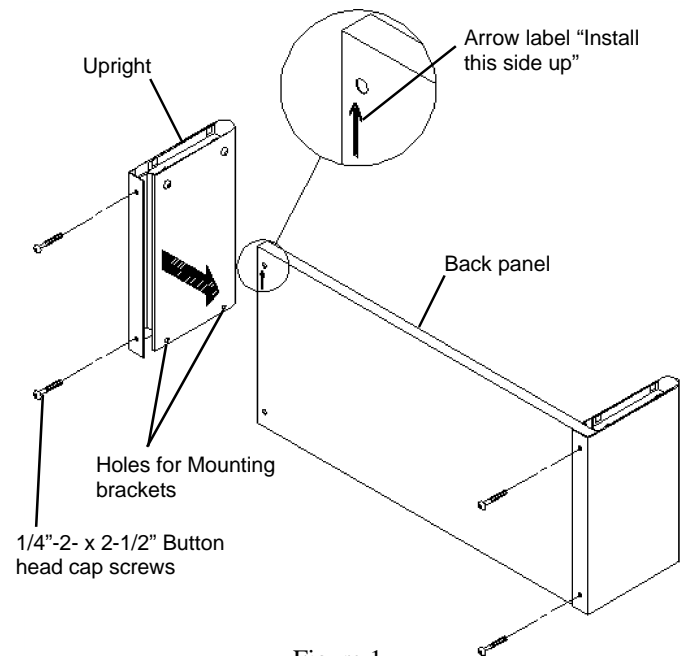

Figure 1

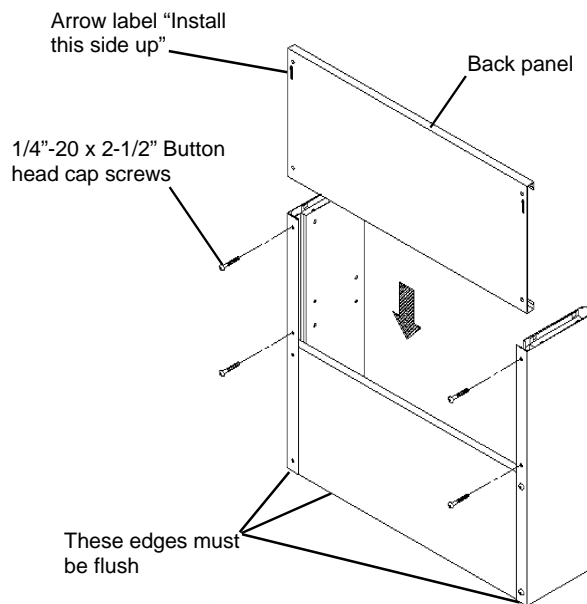

Figure 2

FASTENING THE ORGANIZER TO A LINX WORKSURFACE

1. Using the cardboard **Drill Template** provided, drill two 1/8" diameter holes approximately 1/2" deep into the two corners of the Linx Corner Workstation as shown in **Figure 1**.

Carefully fold the template along perforations and place the template on the corner of the worksurface as shown in **Figure 2**.

Fold the tab on the opposite end of the template for the

2. Install a **Mounting Bracket** at each corner of the worksurface with the #10 x 3/4" Phillips pan head screws provided. See **Figure 4**.
3. With two people, carefully lift and place the Organizer on the worksurface with the bottom of the Uprights fitting down over the Mounting Brackets.

Secure the Uprights to the Mounting Brackets with the four 1/4"-20 x 1/2" Button head cap screws provided. Tighten the screws with the 5/32" Allen wrench. See **Figure 5**.

4. Install the two **Top Caps**. See **Figure 5**.

IMPORTANT! The Linx Organizer must be fastened to the worksurface.

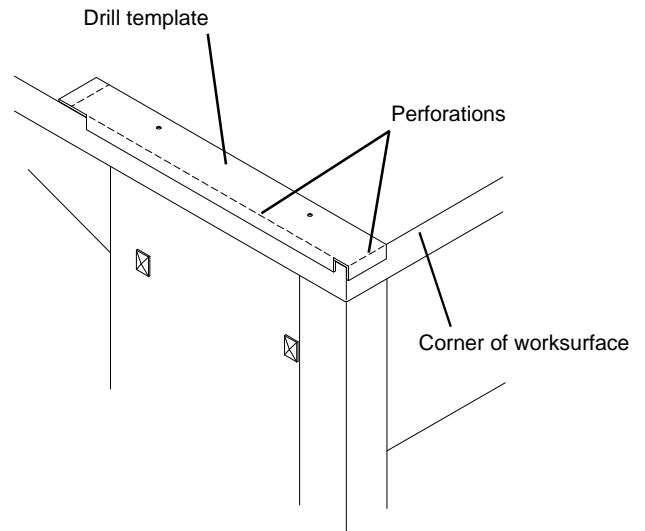

Figure 3

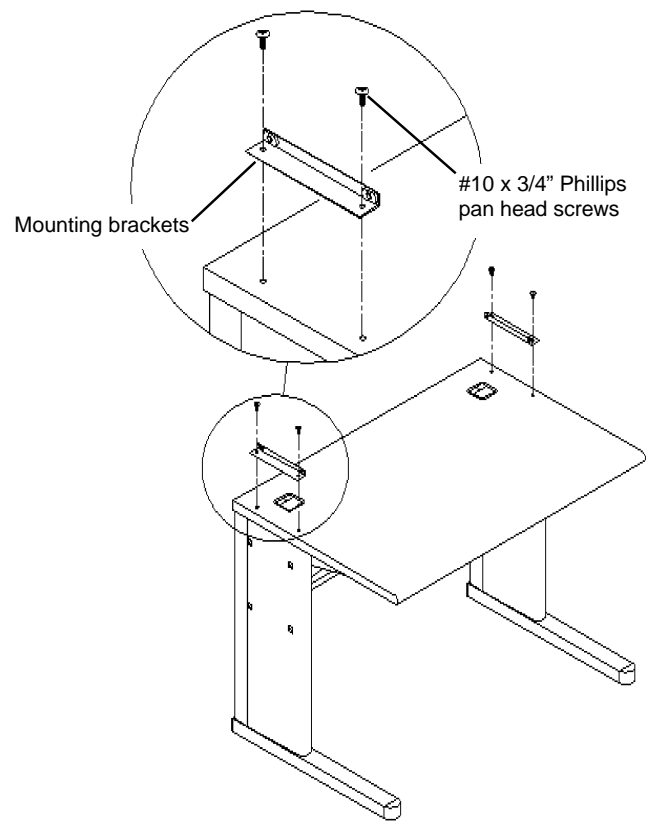

Figure 4

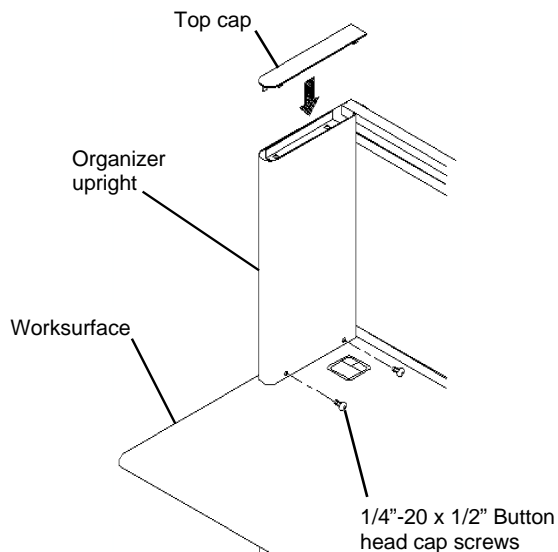

Figure 5

FASTENING THE ORGANIZER TO NON-WRIGHT LINE MANUFACTURED WORKSURFACES

If the worksurface to which the Organizer is to be installed is not a Wright Line LINX worksurface, locate and drill the four 1/8" diameter x 1/2" deep holes in the rear corners as indicated below.

NOTE: If the worksurface sides are square to the top and its width is exactly 48", 60", ect., the template may be usable. Mark the holes, measure and compare to the chart below before drilling.

Organizer Size	Distance between holes
24"	22.00"
30"	28.00"
36"	34.00"
48"	46.00"
60"	58.00"
72"	70.00"

After drilling the holes, install the Mounting Brackets according to the instructions on previous page.

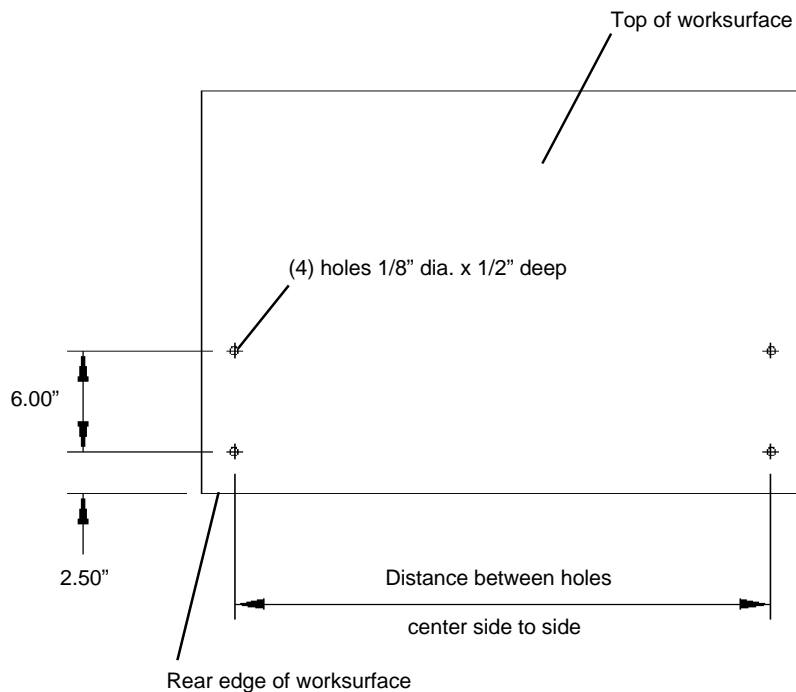

Tools Required

- Phillips head screwdriver
- 5/32" Allen wrench

Caution: The **Workstation Organizer** must be securely attached to a Worksurface before proceeding with the installation of any component. Failure to secure the Organizer may cause tipping and personal injury.

The **Workstation Organizer Locking Compartment, Shelf, and Task Light** components are ordered separately. Each component is comprised of the following:

LOCKING COMPARTMENT

- 2 End Panels
- 1 Shelf
- 1-2 Top Panels
- 1-2 Receiving Doors

SHELF

- 2 End Panels
- 1 Shelf
- 3 Dividers

TASK LIGHT

- 24" or 48" Task Light

END PANEL INSTALLATION

LOCKING COMPARTMENT

1. Two identical **End Panels** are provided for each Locking Compartment. Each End Panel may be used in either the Left hand or Right hand position.

Position one End Panel against the Organizer's R.H. Upright as shown in **Figure 1**. Install and tighten four 1/4"-20 Phillips head screws to secure the End Panel. Fasten the remaining End Panel to the L.H. Upright in the same manner.

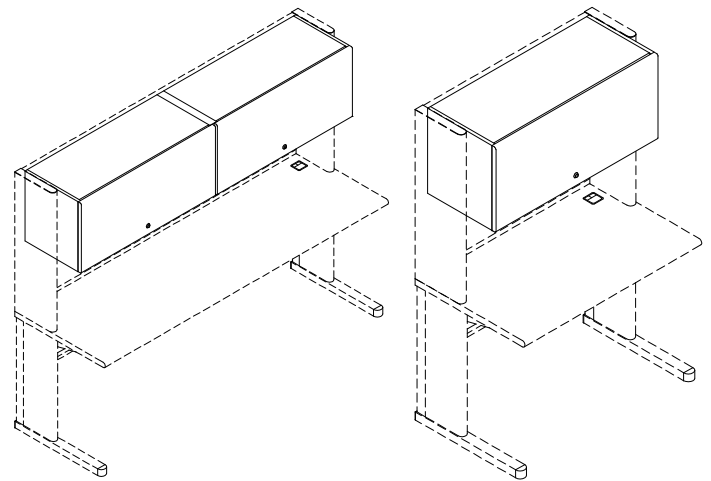

Locking Compartments With Shelves and Task Lights

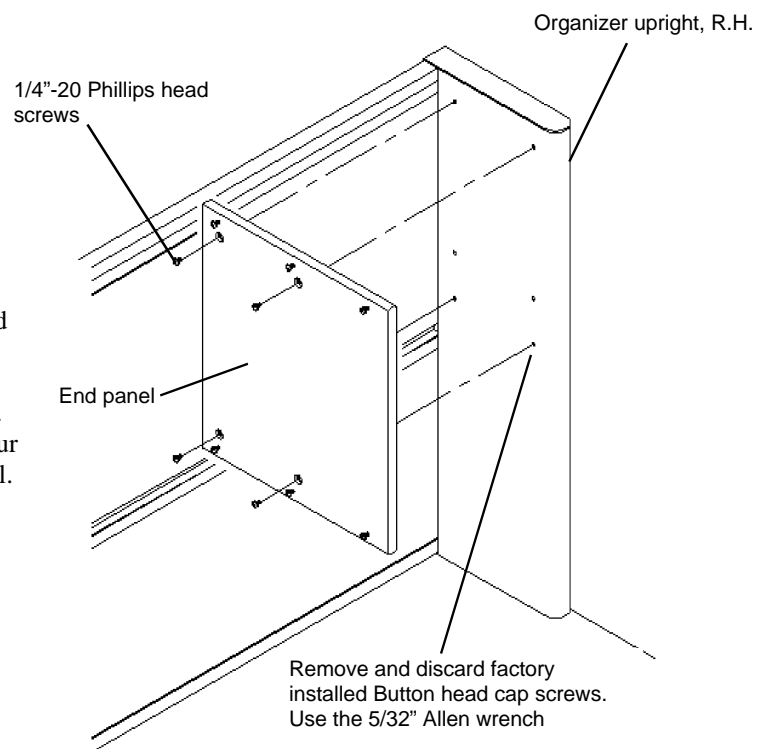

Figure 1a

Locking Compartments (cont.)

END PANEL INSTALLATION (cont.)

FULL LENGTH SHELF

1. A **Full Length Shelf** may be positioned at any of three levels as shown in **Figure 3b**. Position the R.H. End Panel against the Organizer's R.H. Upright at the desired level. The three factory installed screws must be along the bottom edge of the End Panel. Install and tighten two 1/4"-20 Phillips head screws to secure the End Panel. Fasten the remaining End Panel to the L.H. Upright in the same manner.

CAUTION: Do not exceed the evenly distributed shelf load limit of 200 lbs.

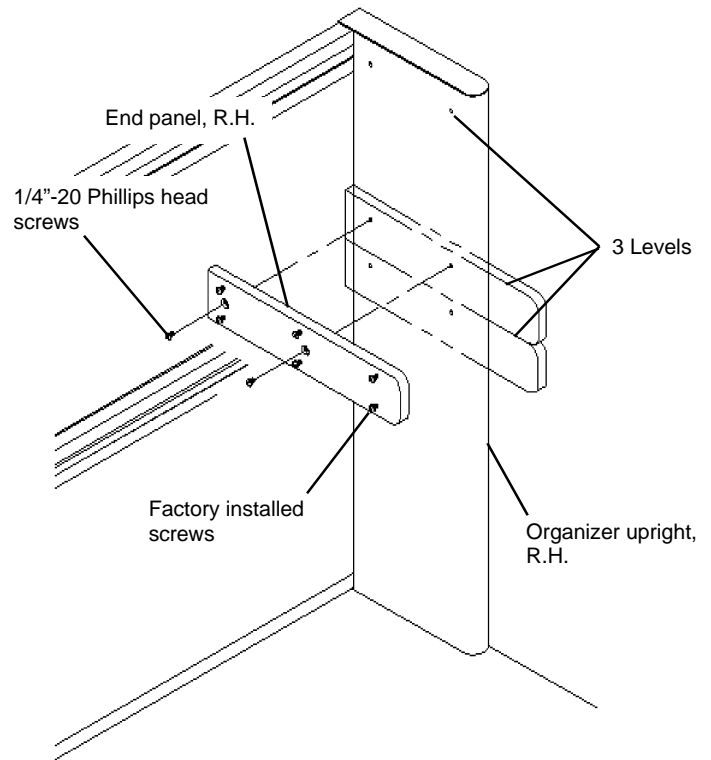

Figure 1b

SHELF INSTALLATION

1. There are three factory screws installed along the bottom edge of each End Panel. These screws must be backed out approximately 1/8" as shown in **Figure 2** (inset).

After backing out all six lower screws, position the **Shelf** between the End Panels above the screws. Lower the Shelf so that all six screws engage their corresponding slots in the Shelf. Tighten the screws to secure the Shelf. See **Figure 2**.

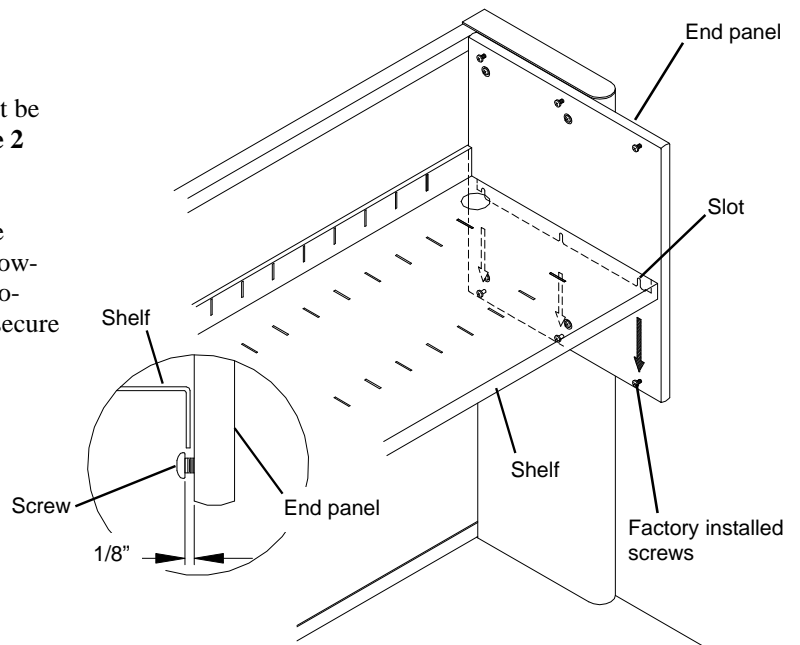

Figure 2

Locking Compartments (cont.)

CENTER PANEL INSTALLATION (66" and 72" Locking Compartment)

The Locking Compartments for the 66" and 72" Organizers require a **Center Panel** to support the two Top Panel and Receding Door assemblies.

1. Locate the **Center Panel** over the center of the shelf and hook the **Rear Bracket** into the top slot on the **Back Panel** as shown in **Figure 3**.
2. Position the **Center Panel** over the three 1/4" diameter holes located in the center of the Shelf and fasten it to the Shelf with the three #10 x 3/4" screws provided. **Do not tighten them at this time.** See **Figure 3**.

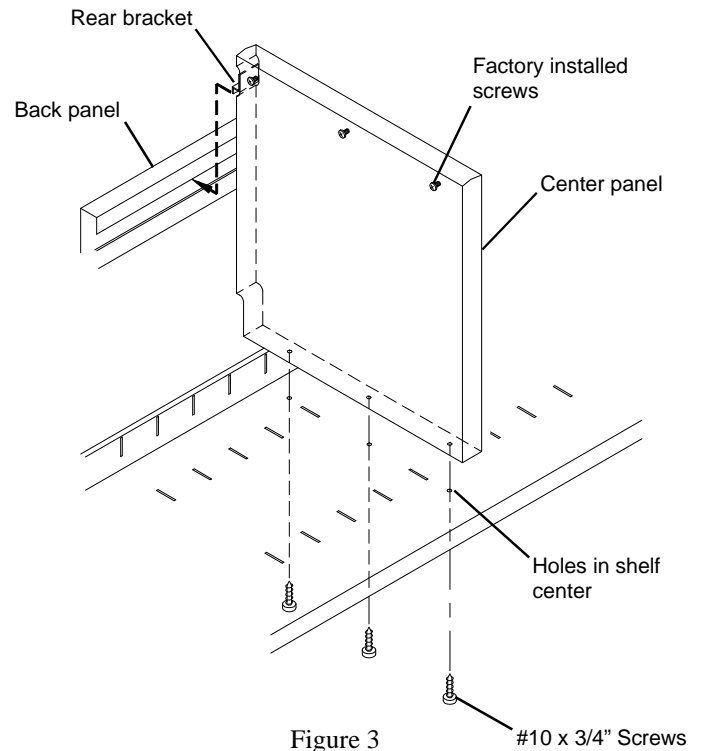

Figure 3

TOP PANEL INSTALLATION

1. Be sure the three screws along the top edge of each End Panel are backed out 1/8" as shown in **Figure 4**.
2. Position the **Top Panel** above the screws. The **Receding Door** mounting holes must face forward. Lower the **Top Panel** onto the screws so that the six screws engage their corresponding slots in the **Top Panel**. See **Figure 3**.
3. Now tighten the screws to secure the **Top Panels** to the **End Panels**.
4. Apply the **Rubber Bumpers** to each end of the **Shelf** as shown in **Figure 4**.

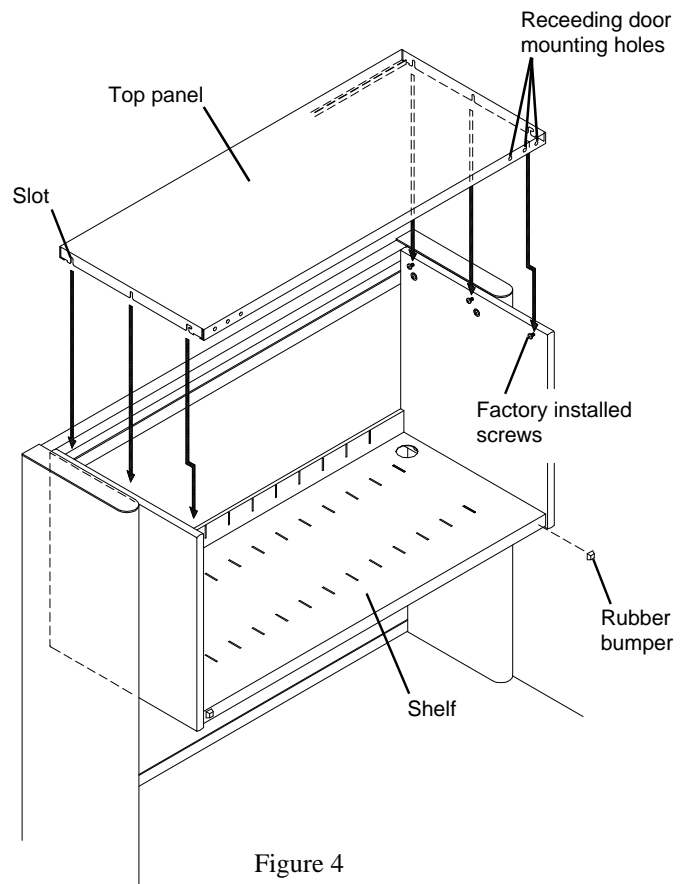

Figure 4

Locking Compartments (cont.)

TOP PANEL INSTALLATION (72" Locking Compartment)

1. Two **Top Panels** are required, installed one at a time. Be sure the three screws along the top edge of each End Panel and on both sides of the Center Panel are backed out 1/8" as shown in **Figure 2**.
2. Position one Top Panel above the six upper screws, three on one End Panel and three on the Center Panel. The Receding Door mounting holes must face forward. Lower the Top Panel onto the screws so that the six screws engage their corresponding slots in the Top Panel. See **Figure 5**.
3. Repeat this procedure with the second Top Panel. Now tighten the screws to secure the Top Panels to the End Panels and the Center Panel to the Shelf.
4. Apply the four **Rubber Bumpers** to each end and center of the Shelf as shown in **Figure 5**.

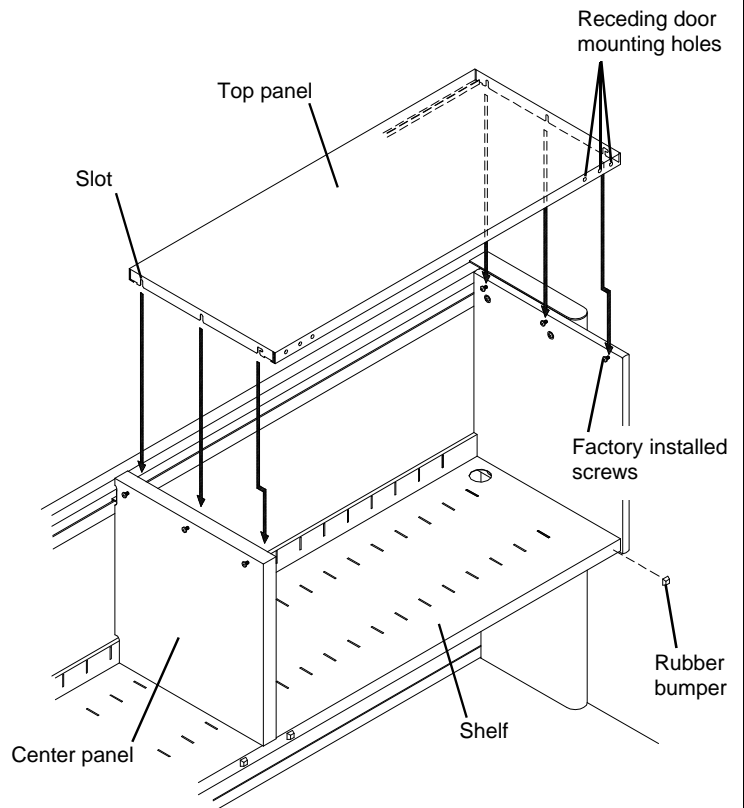

Figure 5

RECEEDING DOOR INSTALLATION

1. Place one Receding Door assembly face up on top of the Locking Compartment. See **Figure 6**. Position the two **Door Track** hinges against the front flange of the Top Panel. The Door edges must be aligned with the outer surfaces of the End Panels. Align the slots in the Door Track Hinges with the six holes in the front flange of the Top Panel. Install and tighten six #8 Phillips head sheet metal screws into the Door Track Hinges to secure them. See note below on 72"/66" doors.

To operate the Receding Door, grasp the lower edge of the door panel near the center and pull the door all the way toward you. Carefully lower the door to the closed position. Reverse this procedure to open the door.

NOTE: Never allow the Receding Door to slam closed. Personal injury or damage to the unit may result.

NOTE: The 72" and 66" Locking Compartments require *two* Receding Doors. To eliminate left and right hand tops, extra door mounting holes have been provided. Use the outer set of three holes on both left and right compartments.

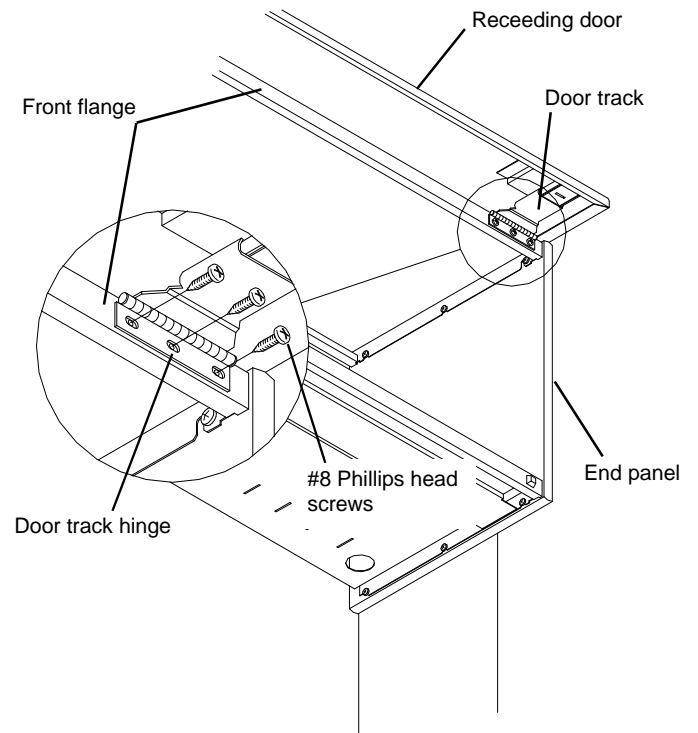

Figure 6

Locking Compartments (cont.)

TASK LIGHT INSTALLATION

24" TASK LIGHT

The **24" Task Light** is installed under the Shelf either at the extreme left, extreme right, or the center position. If desired, two 24" Task Lights may be installed, with one at the extreme left and one at the extreme right.

1. Locate any two screw holes in the Shelf stiffener that are 16" apart. Install two #10 x 3/8" Phillips head sheet metal screws partially into the holes, leaving them protruding approximately 1/16". See **Figure 7**.

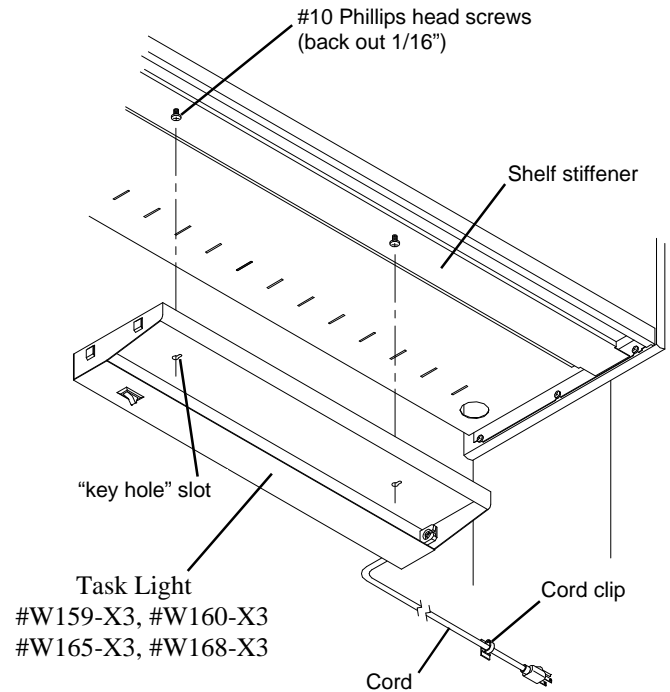

Figure 7

2. Remove the lens and bulb from the Task Light . To remove the lens, push it up near the front edge of the Task Light fixture. See **Figure 8**. Remove bulb by rotating it in either direction and then pulling it away from the mounting sockets.
3. Position the Task Light fixture against the Shelf stiffener with the mounting screws protruding thru the large ends of the "key hole" slots. Push the fixture toward the back of the Shelf to seat the screws into the narrow portion of the slots and then tighten the screws.

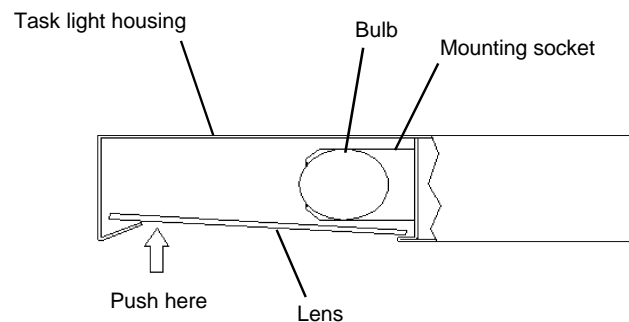

Figure 8. Removing lens and bulb

4. Now replace the bulb and the lens. The corrugated surface of the lens is toward the bulb. See **Figure 9**.

Cable Clips are provided to route and secure the Task Light cord.

NOTE: Fixture must be plugged into a three pronged grounded outlet.

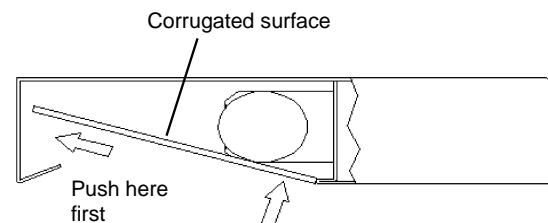

Figure 9. Replacing lens and bulb

Locking Compartments (cont.)

48" TASK LIGHT

The **48" Task Light** can only be installed in the center position.

1. Locate the two screw holes in the Shelf stiffener that are 40" apart. Install two #10 x 3/8" Phillips head sheet metal screws partially into the holes, leaving them protruding approximately 1/16". See **Figure 10**.

Install the 48" Task Light following the balance of the instructions for the 24" Task Light

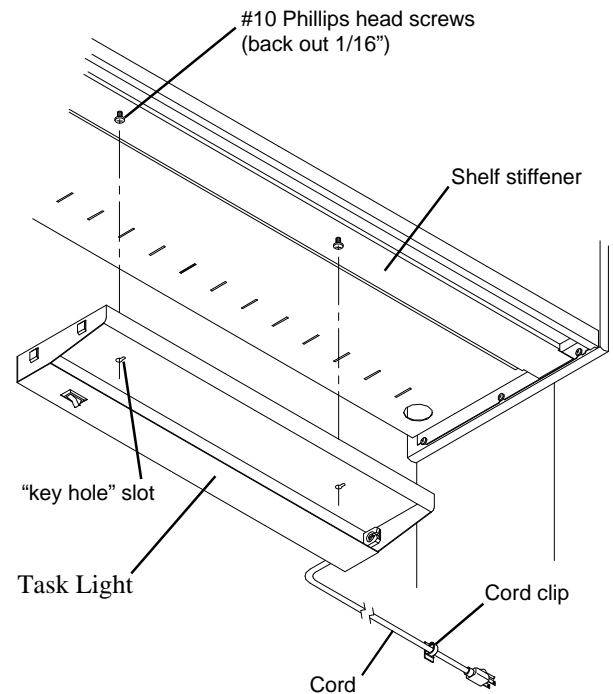

Figure 10

technical furniture

Locking Compartments (c o n t .)

Parts List

Part Number	Description	Qty.
1	6584X Shelf, 24"	1
	2217X Shelf, 30"	
	2219X Shelf, 36"	
	4715X Shelf, 42"	
	1546X Shelf, 48"	
	3768X Shelf, 54"	
	1544X Shelf, 60"	
	3769X Shelf, 66"	
	2218X Shelf, 72"	
2	1531X End Panel	2
3	1533X End Panel, Shelf	2
4	8227X Top, 24"	1-2
	8228X Top, 30"	
	8229X Top, 36"	
	8230X Top, 42"	
	8231X Top, 48"	
	8232X Top, 54"	
	8233X Top, 60"	
	8234X Top, 66"	
8235X Top, 72"		

Parts List

Part Number	Description	Qty.
5	8191X Receeding Door Assembly, 24"	1-2
	8192X Receeding Door Assembly, 30"	
	8193X Receeding Door Assembly, 36"	
	8194X Receeding Door Assembly, 42"	
	8195X Receeding Door Assembly, 48"	
	8196X Receeding Door Assembly, 54"	
	8197X Receeding Door Assembly, 60"	
	8198X Receeding Door Assembly, 66"	
	8199X Receeding Door Assembly, 72"	
6	8246X Center Panel Assembly	1
7	59103 #10AB x .75" Phillips Head Thread Forming Screw	3
8	53956 1/4"-20 x 3/4" Phillips Pan Head Machine Screw	8
9	66249 #8 x 3/8" Phillips Pan Head Screw	12
10	22791 Bumper	8
11	1575X Dividers (not shown)	3

technical furniture

Locking Compartments (cont.)

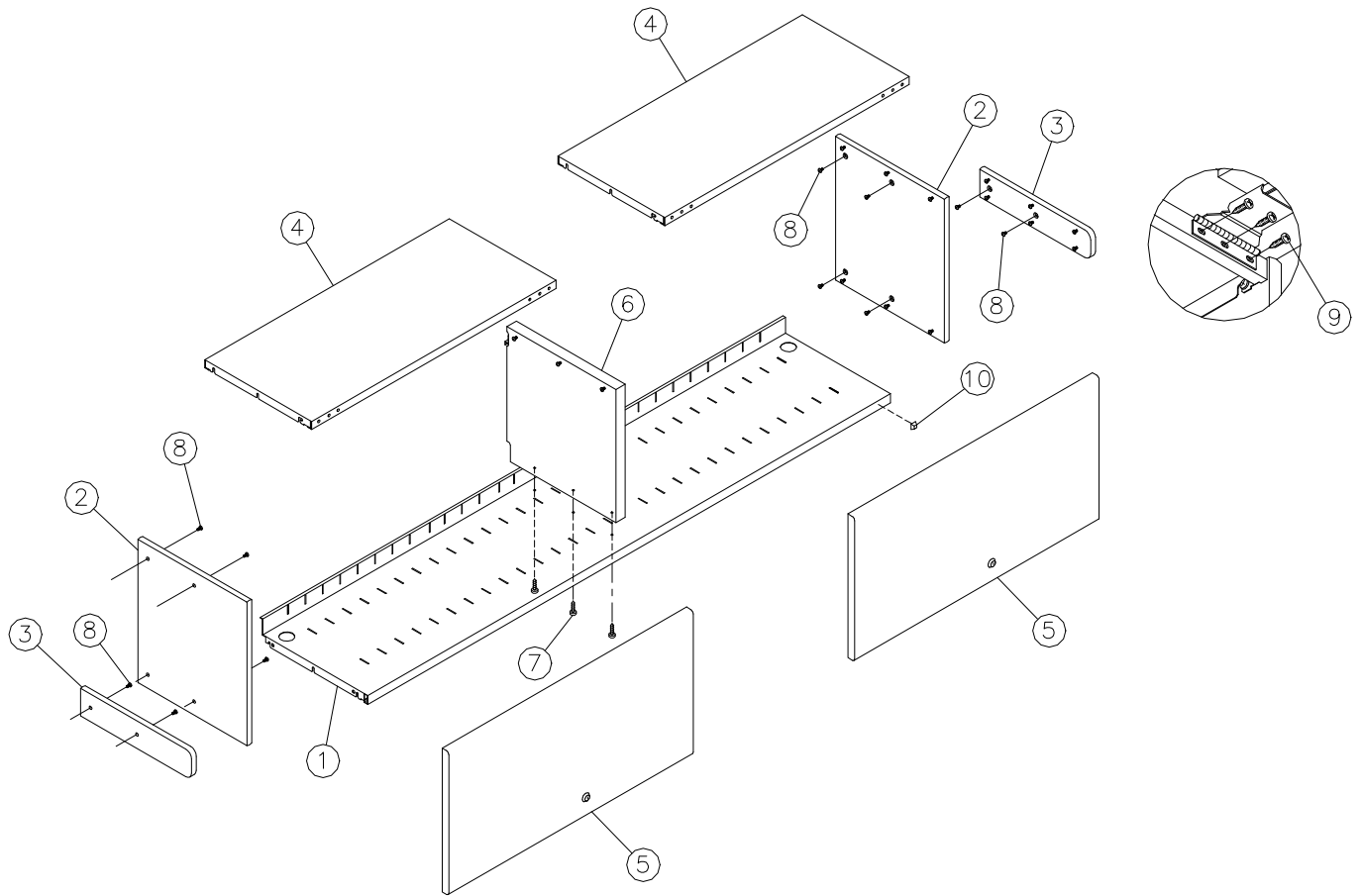

Pass-Through Organizers

Tools Required

- Phillips head screwdriver
- 5/32" Allen wrench (provided)
- Electric drill
- 1/8" Drill bit
- Drill template (provided)

IMPORTANT: It is recommended that the assembly of this product be done on the floor. Assistance may be required.

ASSEMBLING THE ORGANIZER

1. Carefully insert the **Channel Fillers** into the **Uprights**. Be sure that the holes for Mounting Brackets are at the bottom of the Uprights. See **Figure 1**.
2. Install the 1/4"-20 x 2-1/2" Button head cap screws through the Uprights and through the Channel Fillers. Thread the screws in until their heads touch the Uprights (snug fit). **DO NOT TIGHTEN**. See **Figure 1**.
3. Slide the **Back Panel** down from the top and install the button head cap screws in the same fashion as in step 2. See **Figure 1**.
4. Make sure that the bottom of the Channel Fillers and Uprights are flush. Starting at the bottom, tighten each screw 1/4 turn from the snug position. **DO NOT OVER TIGHTEN**.

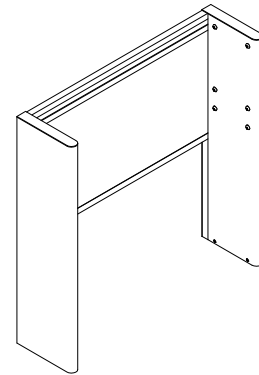

Pass-Through Organizers

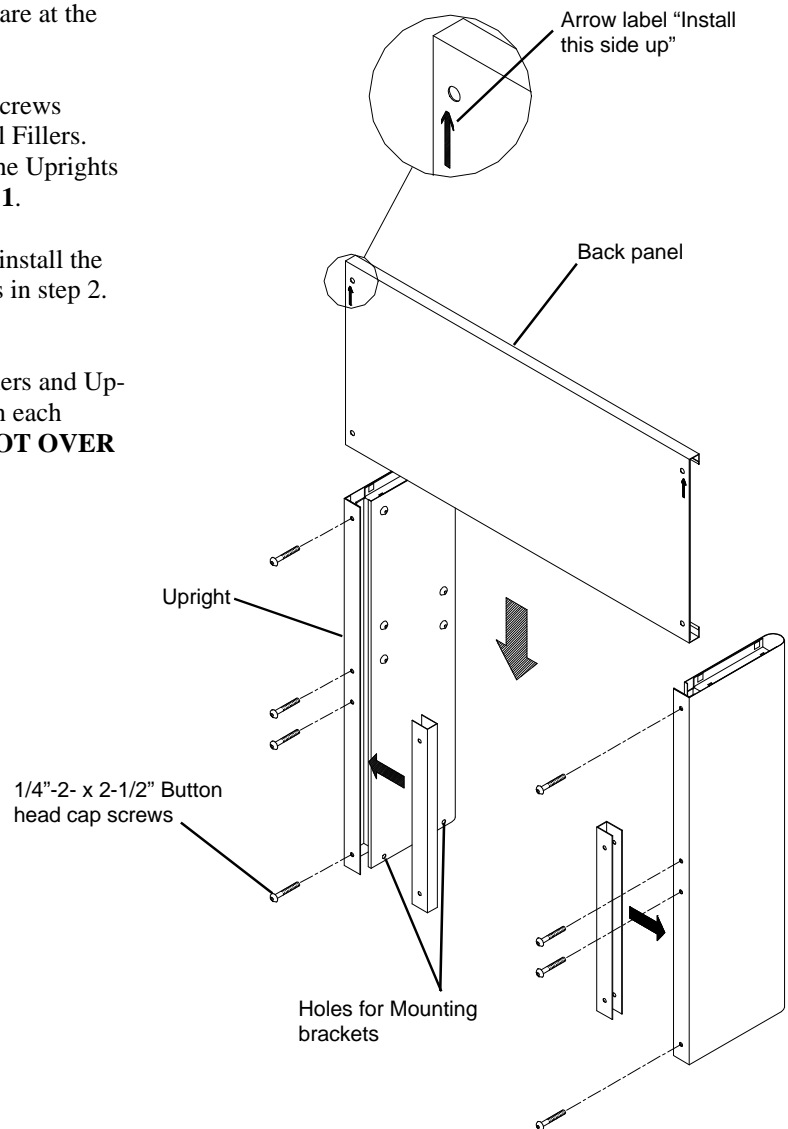

Figure 1

FASTENING THE ORGANIZER TO A LINX WORKSURFACE

1. Using the cardboard **Drill Template** provided, drill two 1/8" diameter holes approximately 1/2" deep into the two corners of the Linx Worksurface as shown in **Figure 2**.

Carefully fold the template along perforations and place the template on the corner of the worksurface as shown in **Figure 2**.

Fold the tab on the opposite end of the template for the other corner of the worksurface.

2. Install a **Mounting Bracket** at each corner of the worksurface with the #10 x 3/4" Phillips pan head screws provided. See **Figure 3**.
3. With two people, carefully lift and place the Organizer on the worksurface with the bottom of the Uprights fitting down over the Mounting Brackets.

Secure the Uprights to the Mounting Brackets with the four 1/4"-20 x 1/2" Button head cap screws provided. Tighten the screws with the 5/32" Allen wrench. See **Figure 4**.

4. Install the two **Top Caps**. See **Figure 4**.

IMPORTANT! The Linx Organizer must be fastened to the worksurface.

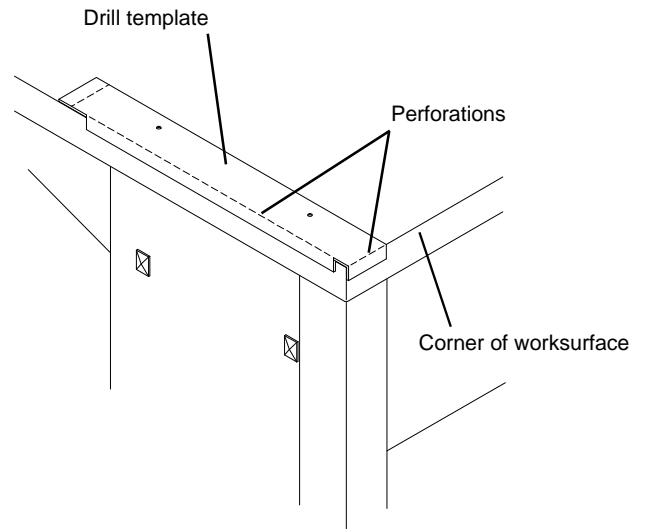

Figure 2

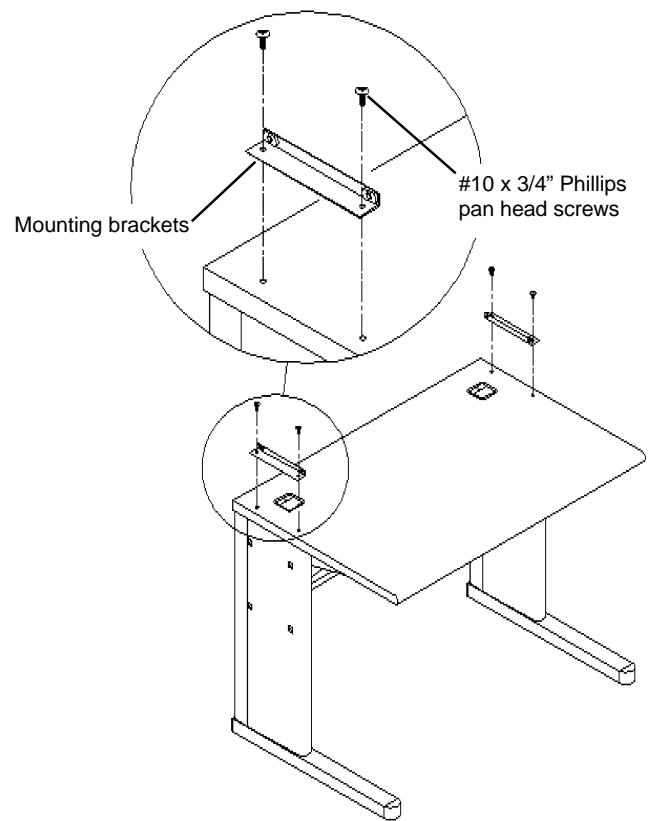

Figure 3

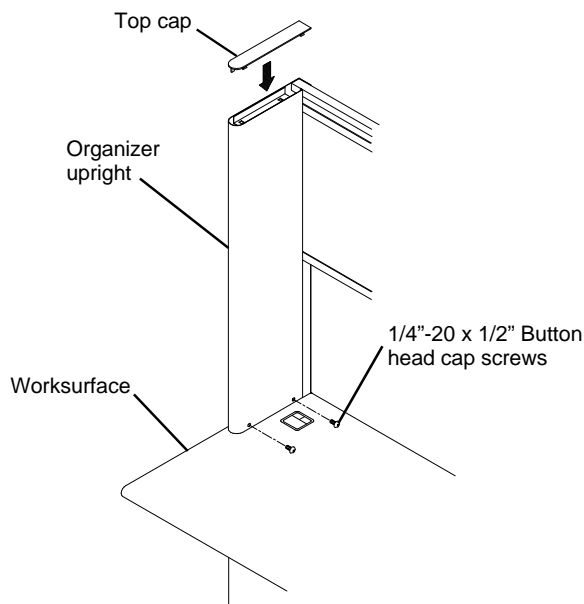
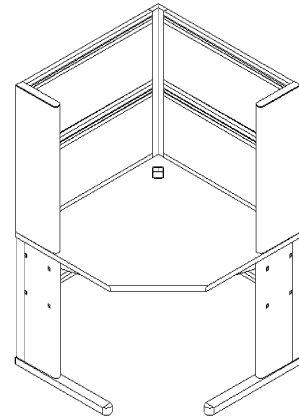

Figure 4

Corner Workstation Organizer

Tools Required

- Phillips head screwdriver
- 5/32" Allen wrench (provided)
- Electric drill
- 1/8" Drill bit
- Drill template (provided)



Corner Workstation Organizer

1. Using the cardboard **Drill Template** provided, drill two 1/8" diameter holes approximately 1/2" deep into the two corners of the Linx Corner Workstation as shown in

Figure 1.

Carefully fold the template along perforations and place the template on the corner of the worksurface as shown in **Figure 2.**

Fold the tab on the opposite end of the template for the other corner of the worksurface.

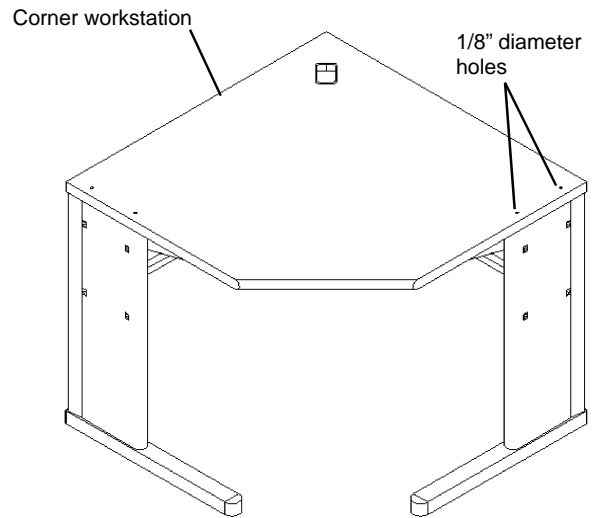

Figure 1

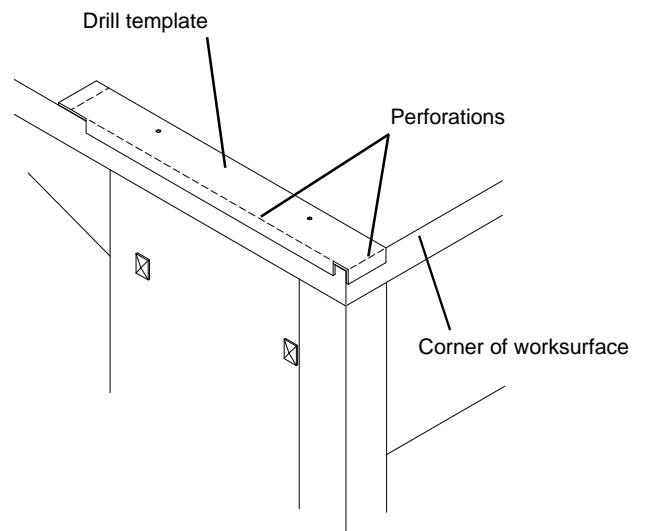

Figure 2

Corner Workstation Organizer (cont.)

2. Install **Mounting Brackets** at each corner of the work-surface with the #10 x 3/4" Phillips pan head screws provided. See **Figure 3**.

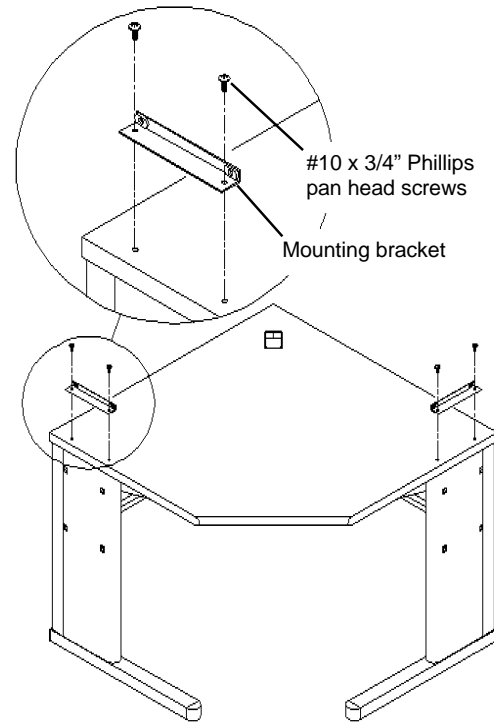

Figure 3

3. Install an **Upright** at each corner of the worksurface by fitting the Uprights down over the Mounting Brackets.

Secure the Uprights to the Mounting Brackets with the four 1/4"-20 x 1/2" Button head cap screws provided. See **Figure 4**.

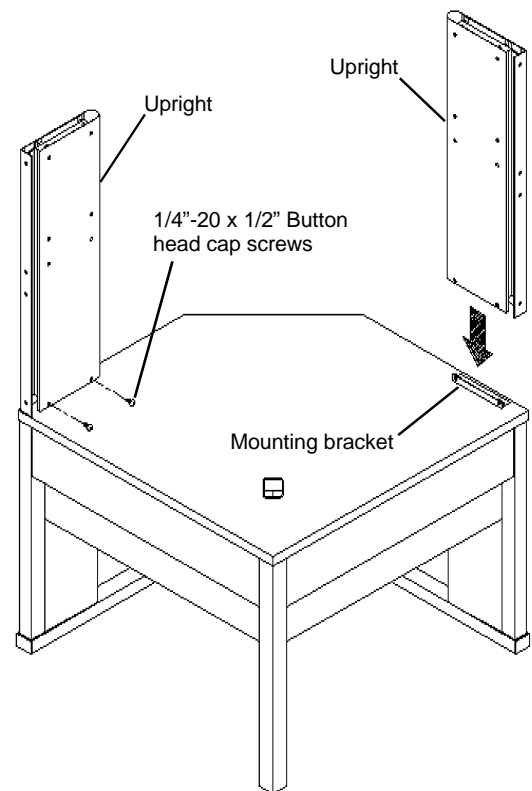

Figure 4

Corner Workstation Organizer (cont.)

4. Insert one end of a **Back Panel** into an **Upright** and then install two 1/4"-20 x 2-1/2" Button head cap screws into the back of the Upright. Thread the screws in until their heads touch the Upright (snug fit). **DO NOT TIGHTEN**. See **Figure 5**.

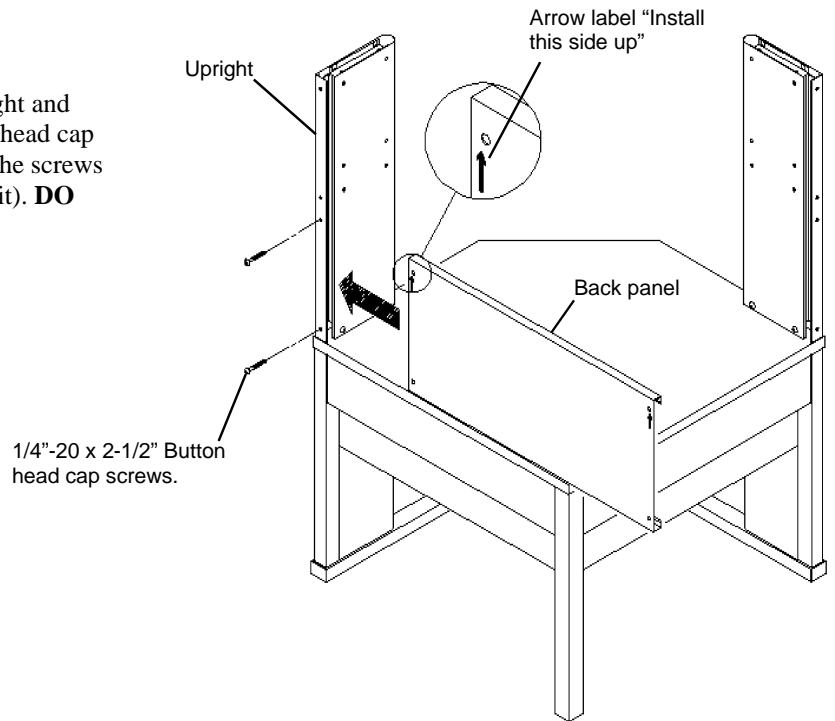

Figure 5

5. Install the remaining **Back panel(s)** as shown in **Figure 6**. If you are installing a 32" or 36" high unit, be careful to keep the unfastened ends of the **Back Panels** together. Apply a length of tape as shown if required.
6. Install the **Front and Rear Corner Connectors** sandwiching the **Back Panels** between them. See **Figure 6**.

NOTE: If one or more of the **Back Panels** contain a **Fabric Tack Panel**, it may be necessary to slide the **Tack Panel** toward the **Upright**. This will allow the threaded weld stud on the **Front Connector** to clear the **Panel**. Reposition the **Panel** after the **Corner Connectors** are installed.

Install the 1/4"-20 x 1.00" Button head cap screws through the **Rear Corner Connector** and the **Back Panel** and into the threaded weld stud on the **Front Connector**. Thread the screws in until their heads touch the **Connector** (snug fit). **DO NOT TIGHTEN**. Remove the previously applied tape. See **Figure 6**.

7. With the assembly complete, tighten each screw 1/4 turn more from the snug position starting at the bottom screw. **DO NOT OVER TIGHTEN**.
8. Install two **Top Caps**. See **Figure 6**.

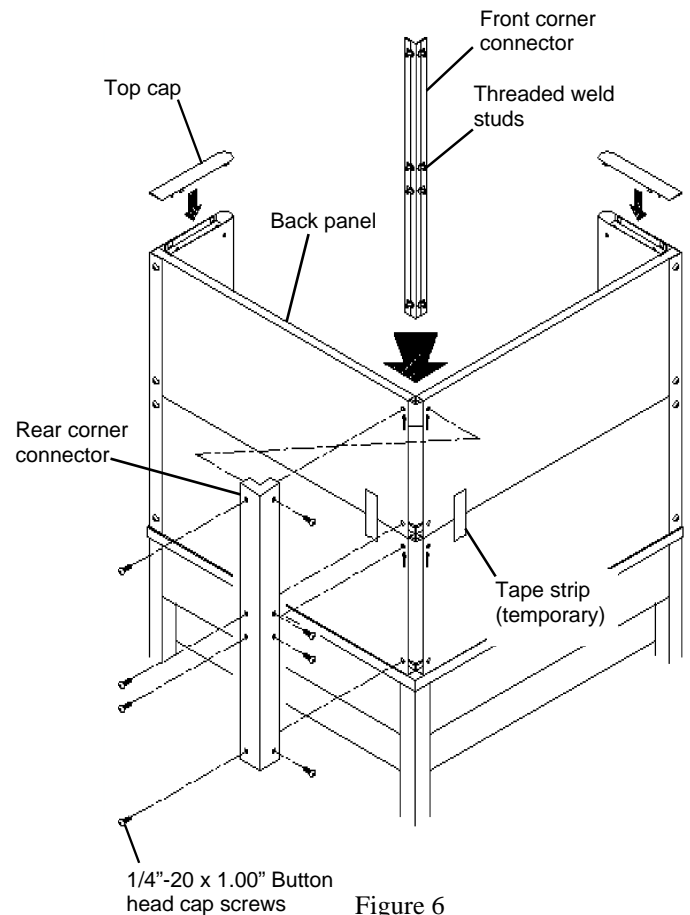

Figure 6

Tools Required

- 5/32" Allen wrench (provided)
- Phillips head screw driver
- Electric drill*
- 1/8" Dia. drill bit*

* Required for the installation of the WD06-XX, 42"(1067mm) x 42"(1067mm) Shelf only.

CAUTION: The Workstation Organizer must be securely attached to a Worksurface before proceeding with the installation of the **Corner Laminate Shelf**.

The Shelf must be securely attached to the Organizer before loading items onto it.

Failure to secure the Organizer and the Shelf may cause tipping and personal injury.

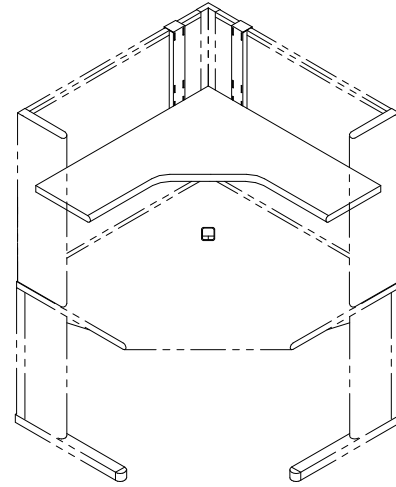

Corner Laminate Shelf

CORNER LAMINATE SHELF INSTALLATION HEIGHTS

The Corner Laminate Shelf may be installed at the following heights on the 16"(406mm), 32"(813mm), and 36"(914mm) high Corner Organizers. See **Figure 1**.

Note: To determine the clear height under the Shelf, subtract 1.20"(30mm) from the heights shown below.

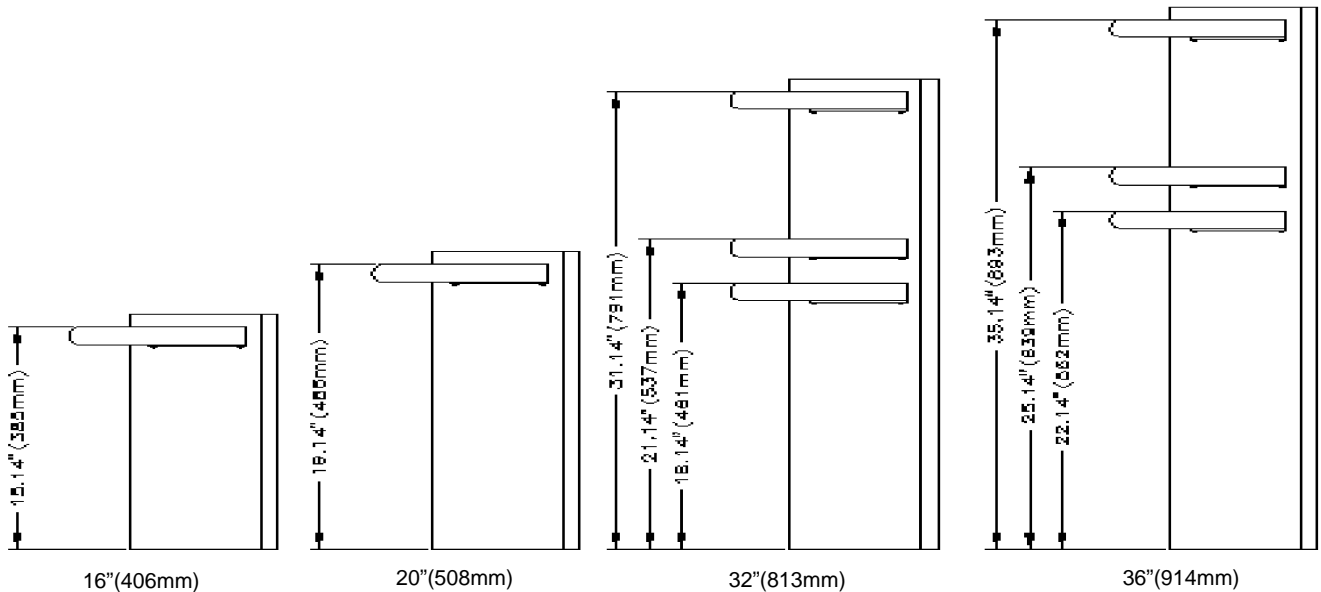

Figure 1

Corner Laminate Shelf (cont.)

1. Determine the Corner Shelf height and remove two 1/4"-20 Button head cap screws from each Upright at the desired height. Use the 5/32" Allen wrench provided. See **Figure 2**.

Save the Button head cap screws; They will be re-used in Step 2.

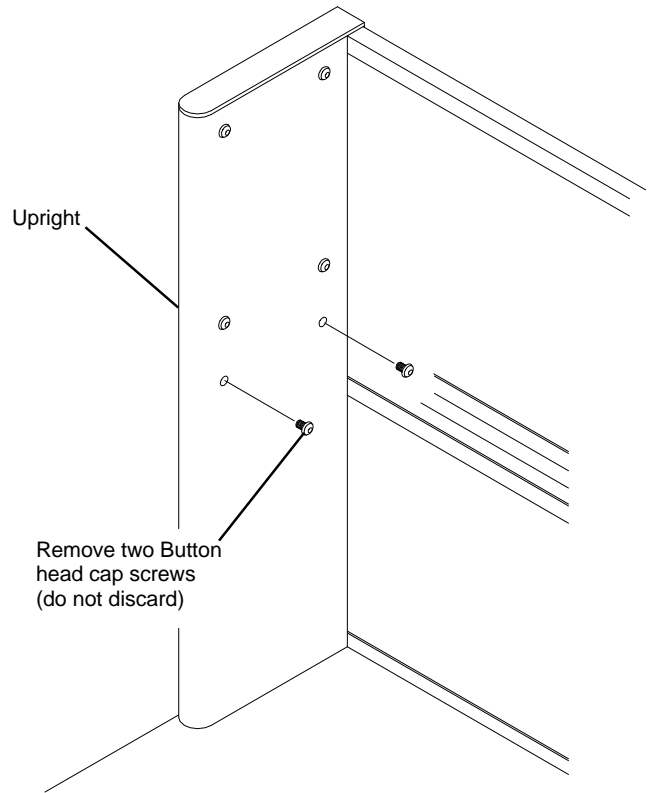

Figure 2

2. Fasten one **Shelf Side Bracket** to each Upright at the desired Shelf height using the Button head cap screws removed in Step 1 and tighten securely. See **Figure 3**.

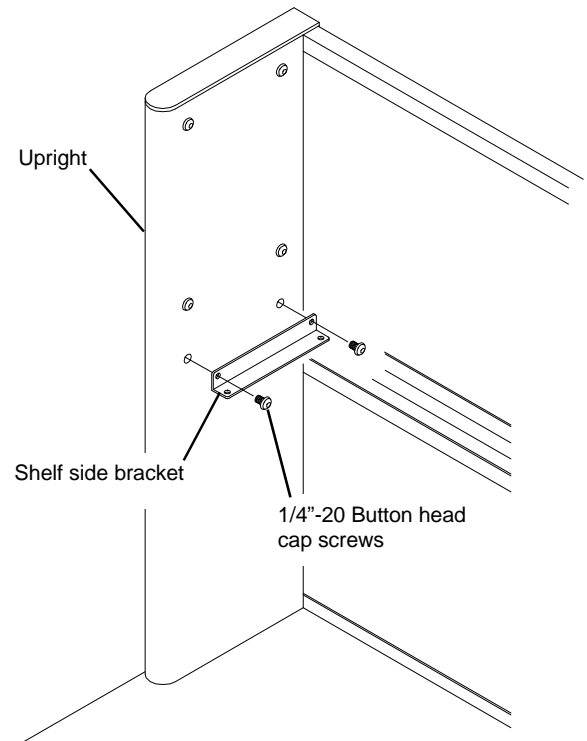

Figure 3

Corner Laminate Shelf (cont.)

3. Install one **Rear Support "A"** and one **Rear Support "B"** on each side of the Organizer. See **Figure 4**.

Ensure that each Rear Support "B" is at the same height as the Shelf Side Brackets.

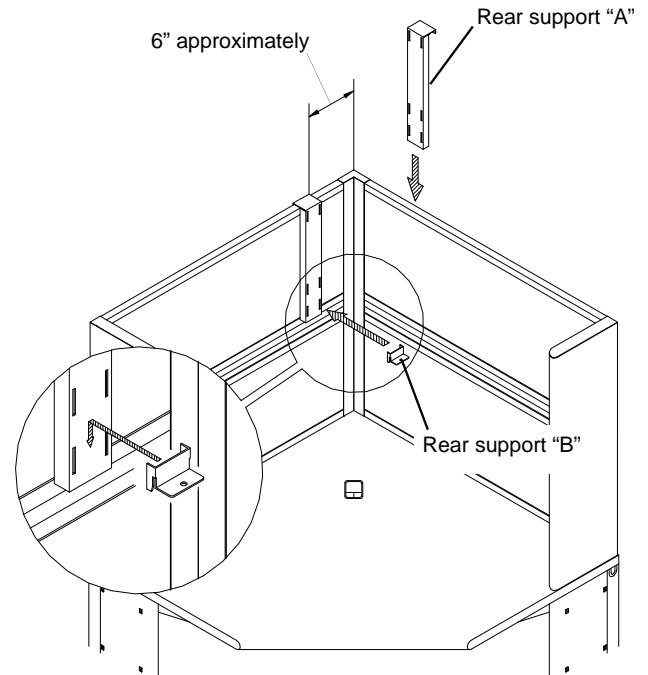

Figure 4

NOTE: All Corner Shelves with the exception of the **WD06-XX** * are pre-drilled. This shelf is not pre-drilled to allow installation of the 12"/18" sides on the desired side of the Organizer.

If you are installing the WD06-XX, position it as desired on the Brackets/Supports and mark the location of the two holes in the Side Brackets on the bottom of the Shelf.

With two people, remove the Shelf and drill four 1/8" diameter holes 1/2" deep into the bottom surface. Then with two people, re-position the Shelf onto the Brackets/Supports.

Fasten the Shelf to the two Side Brackets with four #10 x 3/4" Phillips head screws. See **Figure 5**.

* The WD06-XX Corner Shelf is 42"(1067mm) x 42"(1067mm) with one 12"(305mm) side and one 18"(457mm) side.

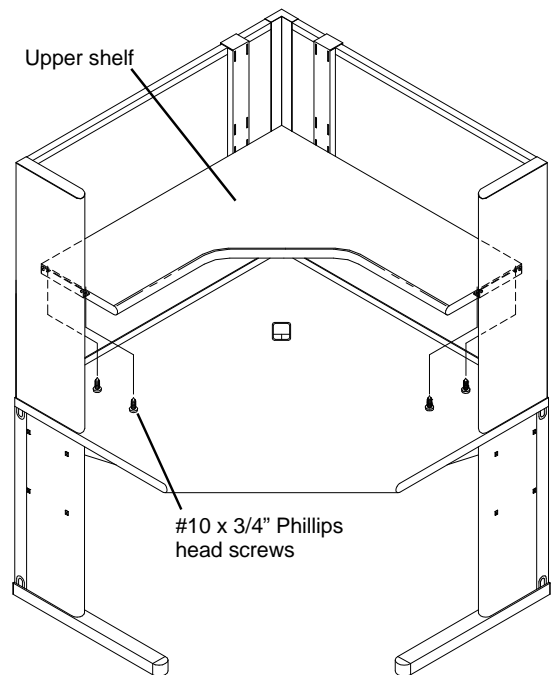
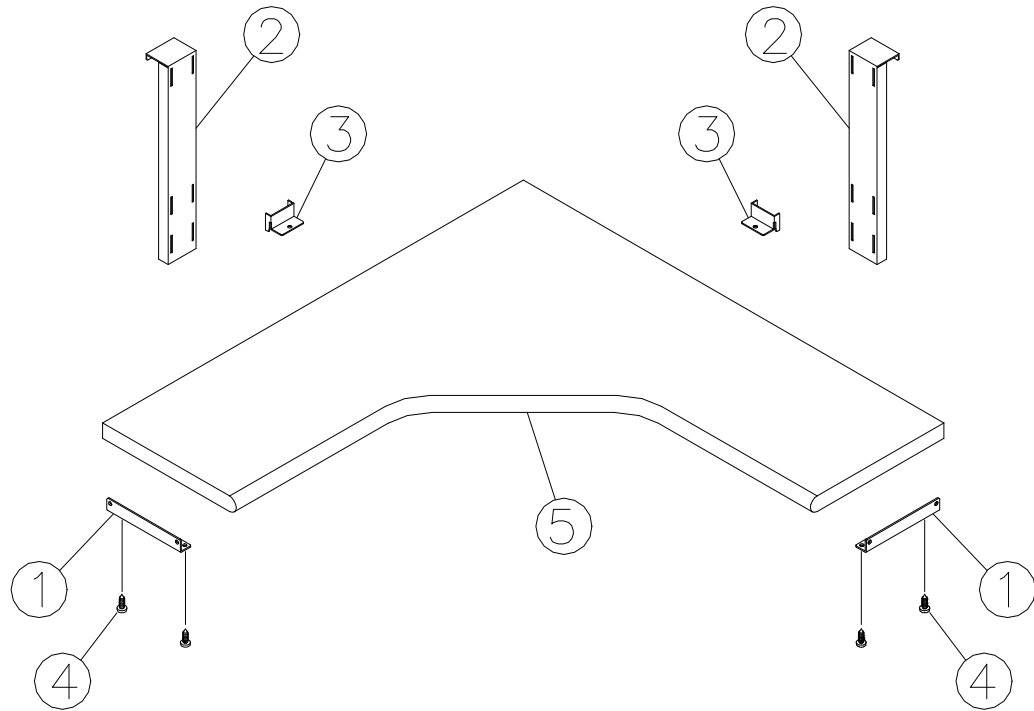

Figure 5

Corner Laminate Shelf (cont.)

Parts List

Part Number	Description	Qty.
1 2287X	Shelf Side Bracket	2
2 2288X	Rear Shelf Support "A"	2
3 2289X	Rear Shelf Support "B"	2
4 59103	#10AB x 3/4" Phillips Head Thread Forming Screw	4
5	2371X 12" Shelf, 30" Corner Workstation Organizer	1
	2372X 12" Shelf, 42" Corner Workstation Organizer	
	2373X 12"/18" Shelf, 42" Corner Workstation Organizer	
	2374X 18" Shelf, 48" Corner Workstation Organizer	



Tools Required

- 5/32" Allen wrench (provided)
- Phillips head screwdriver

1. Using the 5/32" Allen wrench, remove the two 1/4"-20 x .50" Button head cap screws from the top inner surface of the uprights of each organizer receiving a **Reception Surface**. See **Figure 1**. Do not discard the screws; they will be used in Step 2.
2. Attach a **Support** to the top inner surface of each upright using the 1/4"-20 x .50 Button head cap screws removed in Step 1. See **Figure 2**.
3. Position the Reception Surface in place on top of the organizer. Align the pre-drilled holes in the Surface with the holes in the Supports and fasten in place with the #10AB x .75" Phillips head screws (provided). See **Figure 3**.

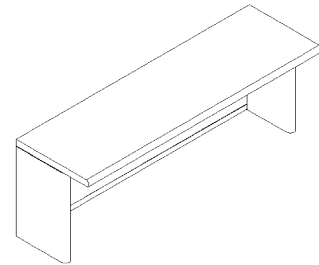

Reception Surface

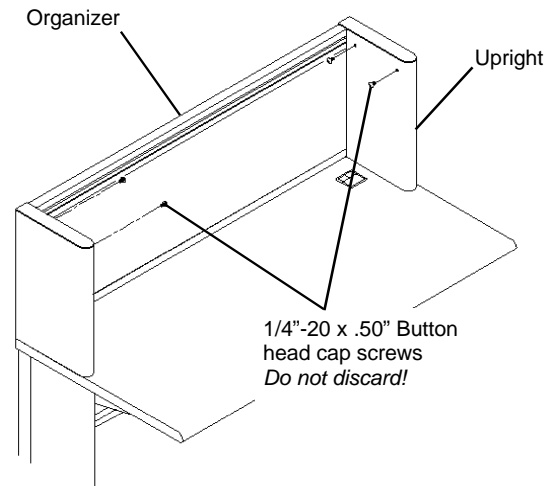

Figure 1

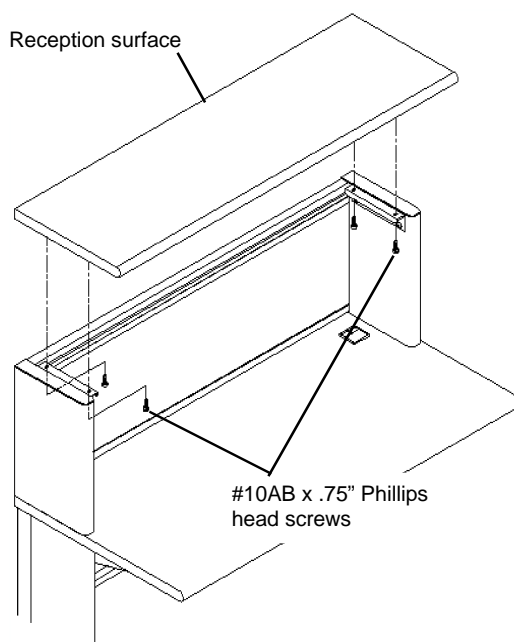

Figure 3

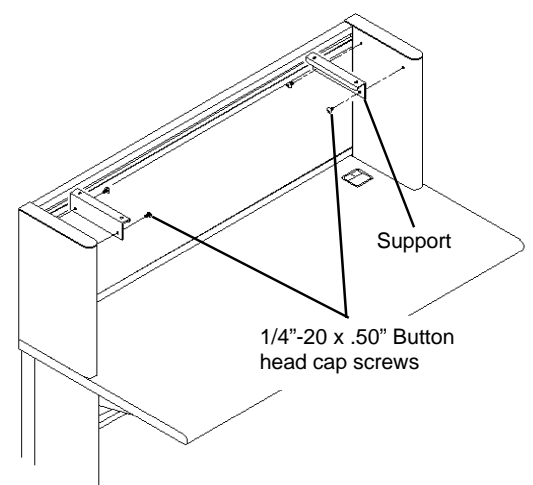
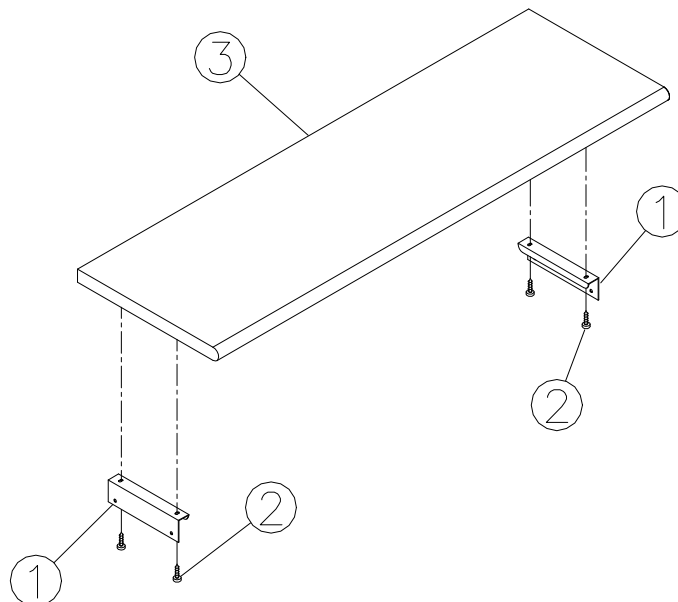

Figure 2

Reception Surface (c o n t .)

Parts List			
Part Number		Description	Qty.
1	4608X	Support	2
2	59103	#10AB x .75" Phillips Head Screw	4
3	5411X	Reception Counter, 15" x 24"	1
	5412X	Reception Counter, 15" x 30"	
	5413X	Reception Counter, 15" x 36"	
	5414X	Reception Counter, 15" x 42"	
	5415X	Reception Counter, 15" x 48"	
	5416X	Reception Counter, 15" x 54"	
	5417X	Reception Counter, 15" x 60"	
	5418X	Reception Counter, 15" x 66"	
	5419X	Reception Counter, 15" x 72"	
	5671X	Reception Counter, 15" x 36", ESD	
	5662X	Reception Counter, 15" x 42", ESD	
	5672X	Reception Counter, 15" x 48", ESD	
	5869X	Reception Counter, 15" x 54", ESD	
	5673X	Reception Counter, 15" x 60", ESD	
5870X	Reception Counter, 15" x 66", ESD		
5674X	Reception Counter, 15" x 72", ESD		



Tools Required

- 5/32" Allen wrench (provided)
- 7/16" Wrench
- Plastic mallet

NOTE: The Shelf is shipped with four shoulder screws installed in the bottom surface. Be careful not to damage other surfaces after unpacking.

1. Remove the **Top Cap** from each of the Organizer uprights. See **Figure 1**.
2. Install a **Plastic Grommet** into each of the two square holes inside the top of each upright. See **Figure 1**.
3. Insert a **Spacer** into the top of each upright with the offset bends toward the inside. See **Figure 2**.

Assemble the **Left** and **Right** hand **Shelf Supports** onto the top of each upright by placing them over the Spacers and securing them with the 1/4"-20 x 3.50" Lag screws and washers provided. **DO NOT** tighten at this time. **IMPORTANT:** Be sure to install the Shelf Supports with the mounting clips facing up. See **Figure 2**. See note below before tightening the screws.

NOTE: To provide side clearance for the Locking Compartment door, the Shelf Supports are .10"(2,5mm) narrower than the uprights to which they are mounted. See **Figure 3**.

Align the outer surfaces of the Shelf Supports with the outer surfaces of the uprights and tighten the lag screws until they just bottom out. **DO NOT OVERTIGHTEN.**

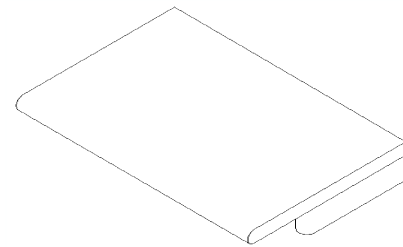

Organizer Overhead Shelf

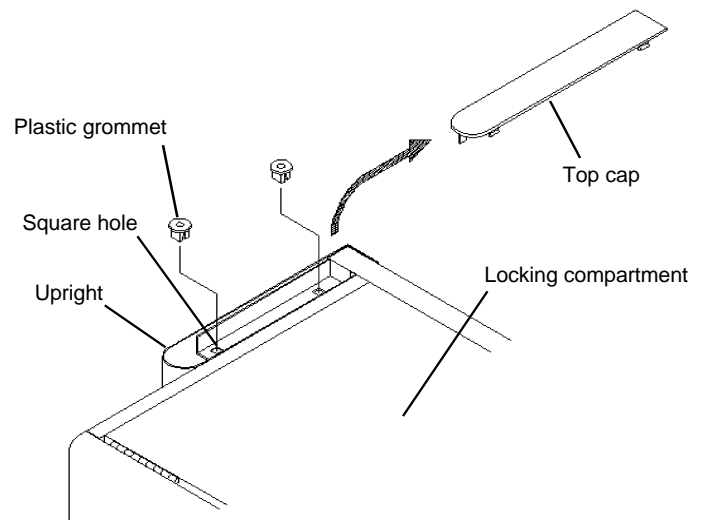

Figure 1

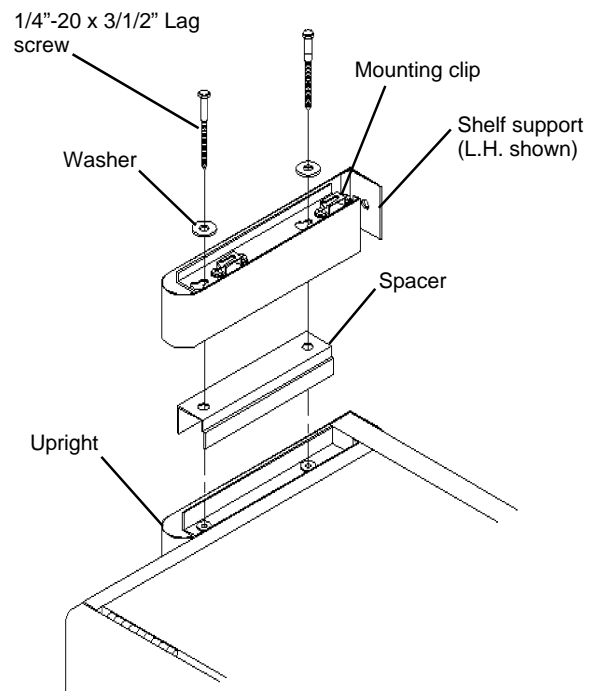

Figure 2

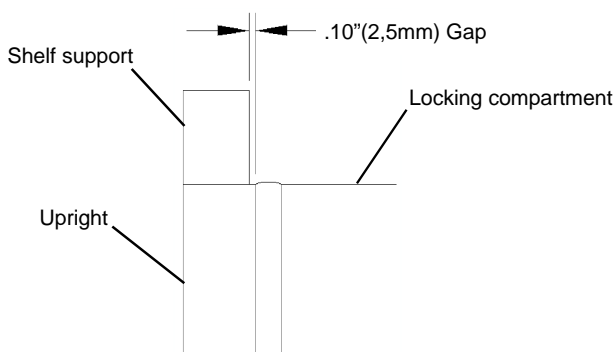

Figure 3

Organizer Overhead Shelf (cont.)

- Four 3/4" squares of double faced adhesive tape have been provided to attach the bottom edge of the Shelf **Rear Panel** to the top of the Organizer back panel.

Attach the four squares of double faced tape , evenly spaced, to the top of the Organizer back panel. See **Figure 4**.

- Install the Shelf **Rear Panel** into the back of the Shelf Supports and fasten it in place with the two 1/4"-20 x 3/8" screws provided. See **Figure 4**.
- If you are installing a 72"(1829mm) wide Shelf, install the **Center Support** to the underside of the Shelf at this time. Use the #10 x 3/4" screws provided. See **Figure 5**.
- With two people, align the shoulder screws in the bottom of the Shelf with the slots in the mounting clips. See **Figure 5**.

Insert the shoulder screws into the slots in the mounting clips and push the Shelf back to seat it. Ensure that the Shelf is fully seated by tapping the front edge of the Shelf with a plastic mallet. If a Support moves backward, re-align it with the upright by tapping it with a plastic mallet.

NOTE: The Shelf can be removed if necessary by grasping one front corner at a time and giving it a sharp pull.

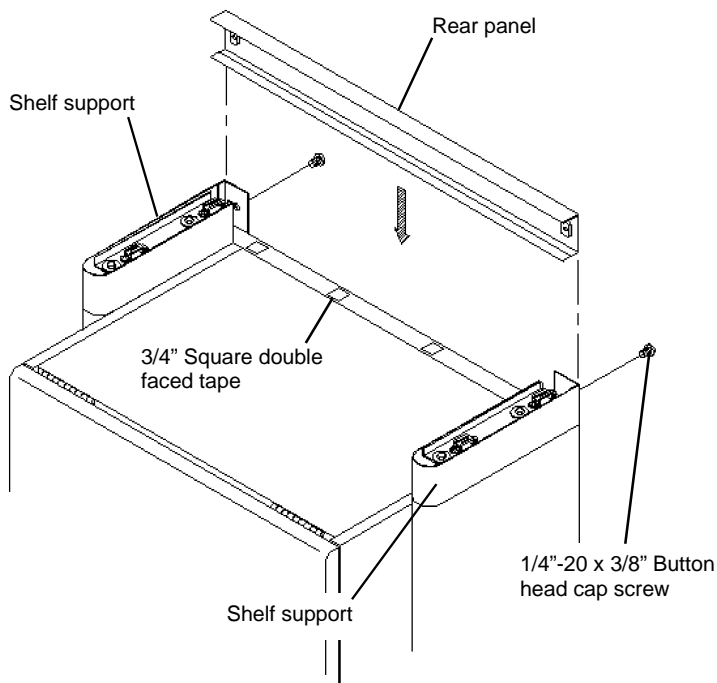

Figure 4

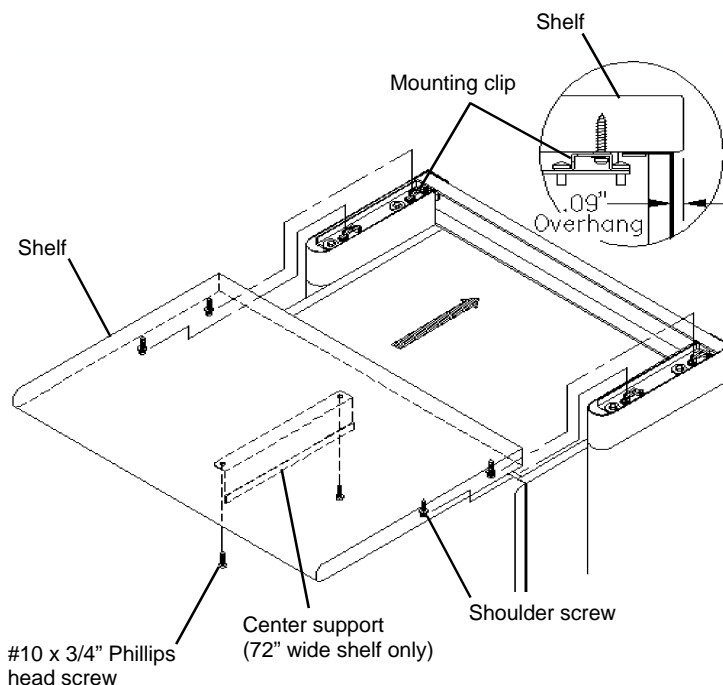

Figure 5

technical furniture

Organizer Overhead Shelf (cont.)

Parts List

Part Number	Description	Qty.
1	2967X 24" Laminated Shelf	1
	2968X 30" Laminated Shelf	
	2969X 36" Laminated Shelf	
	2970X 48" Laminated Shelf	
	2971X 60" Laminated Shelf	
	2971X 72" Laminated Shelf	
2	82248 #12SMT x .88 Screw	4
3	2973X Shelf Support Assembly, L.H.	1
4	2974X Shelf Support Assembly, R.H.	1
5	82246 Spacer	2

Parts List

Part Number	Description	Qty.
6	2960X 24" Rear Panel	1
	2961X 30" Rear Panel	
	2962X 36" Rear Panel	
	2963X 48" Rear Panel	
	2964X 60" Rear Panel	
	2965X 72" Rear Panel	
7	82253 1/4" x 3-1/2" Lag Screw	4
8	81710 5/16" Washer	4
9	22738 Plastic Grommet	4
10	68681 1/4"-20 x 3/8" Button hd Cap Screw	2
11	2966X Center Support	1
12	59103 #10AB x 3/4" Phillips Pan Hd Screw	2
13	53727 Tape Strip	1

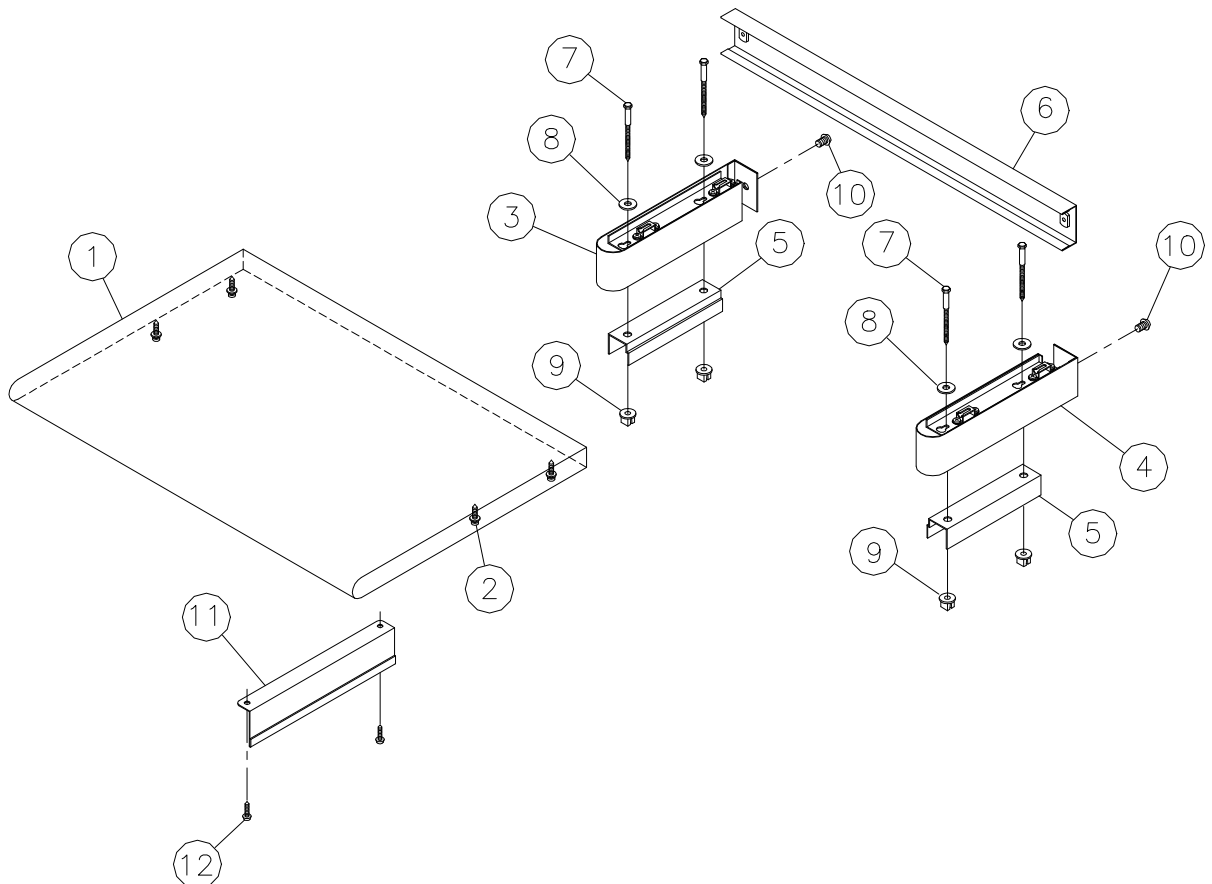

Tackable Fabric Back Panels

Tools Required

-None

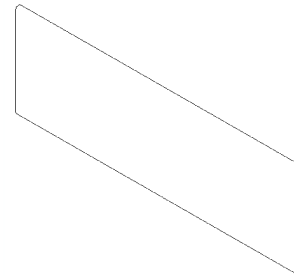

Tackable Fabric Back Panels

NOTE: The LINX Organizer must be fastened to the Worksurface.

1. The **Tackable Fabric Back Panel** has magnetic strips which allows it to be installed on the back of a LINX Organizer. Position the panel on the back of the organizer and adjust it vertically or horizontally as necessary. See **Figure 1**.

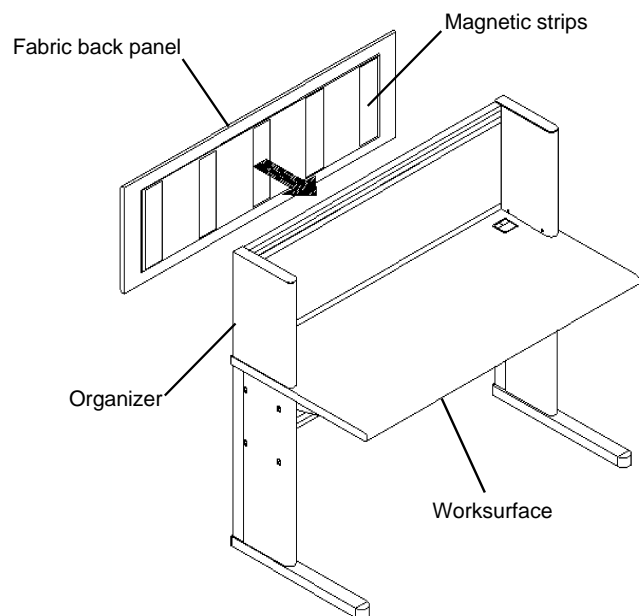

Figure 1

32" or 36" Organizers require two panels. Locate and fasten the top panel first, then the second panel directly below. See **Figure 2**.

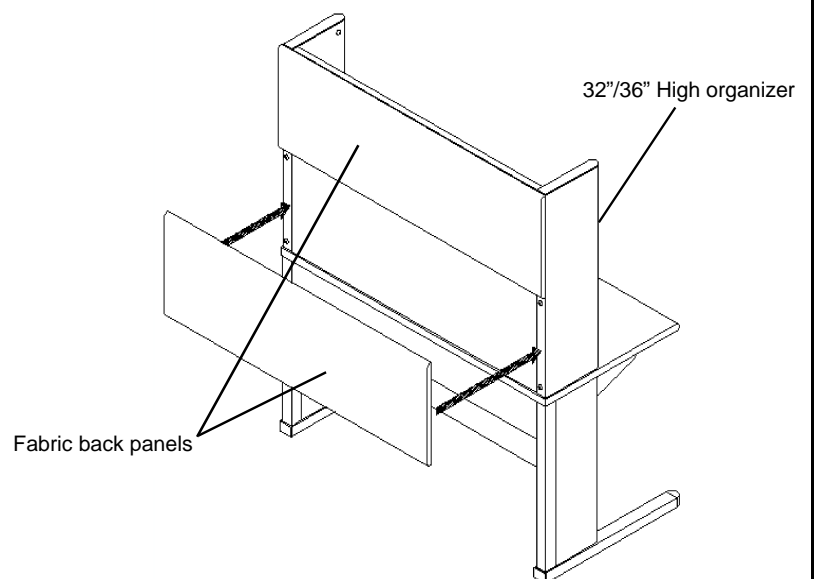
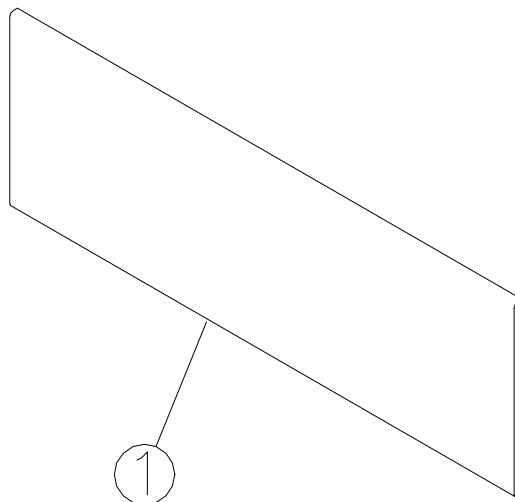

Figure 2

technical furniture

Tackable Fabric Back Panels (cont.)

Parts List			
Part Number		Description	Qty.
	W206-XX	16"H x 24"W Rear Fabric Panel	1
	W306-XX	16"H x 30"W Rear Fabric Panel	
	W366-XX	16"H x 36"W Rear Fabric Panel	
	W436-XX	16"H x 42"W Rear Fabric Panel	
	W406-XX	16"H x 48"W Rear Fabric Panel	
	W506-XX	16"H x 54"W Rear Fabric Panel	
	W606-XX	16"H x 60"W Rear Fabric Panel	
	W678-XX	16"H x 66"W Rear Fabric Panel	
1	W726-XX	16"H x 72"W Rear Fabric Panel	
	W530-XX	20"H x 24"W Rear Fabric Panel	
	W531-XX	20"H x 30"W Rear Fabric Panel	
	W532-XX	20"H x 36"W Rear Fabric Panel	
	W533-XX	20"H x 42"W Rear Fabric Panel	
	W534-XX	20"H x 48"W Rear Fabric Panel	
	W535-XX	20"H x 54"W Rear Fabric Panel	
	W536-XX	20"H x 60"W Rear Fabric Panel	
	W537-XX	20"H x 66"W Rear Fabric Panel	
	W538-XX	20"H x 72"W Rear Fabric Panel	



technical furniture

Workstation Organizers Service Parts List

Parts List

Part Number	Description	Qty.
1	1479X 16" Upright, R.H.	1
	1480X 32" Upright, R.H.	
	4932X 36" Upright, R.H.	
2	1464X 16" Upright, L.H.	1
	1465X 32" Upright, L.H.	
	4931X 36" Upright, L.H.	
3	1454X Cap	2
4	2236X Mounting Bracket	2
5	59103 #10 x 3/4" Phillips Pan Head Screws	4
6	69361 1/4"-20 x 2-1/2" Button Head Cap Screws	4-8
7	82703 1/4"-20 x 1/2" Button Head Cap Screws	4
8	2199X 16" x 24" Back Panel, Fabric	1-2
	2200X 16" x 30" Back Panel, Fabric	
	2201X 16" x 36" Back Panel, Fabric	
	3590X 16" x 42" Back Panel, Fabric	
	1460X 16" x 48" Back Panel, Fabric	
	3760X 16" x 54" Back Panel, Fabric	
	1461X 16" x 60" Back Panel, Fabric	
	3761X 6" x 66" Back Panel, Fabric	
	2202X 16" x 72" Back Panel, Fabric	
	4895X 20" x 24" Back Panel, Fabric	
	4896X 20" x 30" Back Panel, Fabric	
	4897X 20" x 36" Back Panel, Fabric	
	4898X 20" x 42" Back Panel, Fabric	
	3526X 20" x 48" Back Panel, Fabric	
	4899X 20" x 54" Back Panel, Fabric	
3126X 20" x 60" Back Panel, Fabric		

Parts List

Part Number	Description	Qty.
8	4900X 20" x 66" Back Panel, Fabric	1-2
	3773X 20" x 72" Back Panel, Fabric	
	5050X 16" x 24" Back Panel, Fabric	
	2238X 16" x 30" Back Panel, Fabric	
	4106X 16" x 36" Back Panel, Fabric	
	2223X 16" x 42" Back Panel, Fabric	
	2291X 16" x 48" Back Panel, Fabric	
	4908X 16" x 60" Back Panel, Fabric	
	2295X 16" x 72" Back Panel, Fabric	
	5048X 20" x 24" Back Panel, Fabric	
	5049X 20" x 30" Back Panel, Fabric	
	4901X 20" x 36" Back Panel, Fabric	
	4902X 20" x 42" Back Panel, Fabric	
	4903X 20" x 48" Back Panel, Fabric	
	4904X 20" x 60" Back Panel, Fabric	
4905X 20" x 72" Back Panel, Fabric		
9	2234X Rear Corner Connector, 16" High	1
	2224X Rear Corner Connector, 32" High	
	4910X Rear Corner Connector, 36" High	
10	2235X Front Corner Connector, 16" High	1
	2225X Front Corner Connector, 32" High	
	4911X Front Corner Connector, 36" High	
11	81008 1/4"-20 x 1.00" Button Head Cap Screw	4-8

technical furniture

Workstation Organizers Service Parts List (cont.)

Parts List

Part Number	Description	Qty.
84601	Tack Panel, 16" High Back Panels	1-4
84602	Tack Panel, 16" High Back Panels	
84603	Tack Panel, 16" High Back Panels	
84604	Tack Panel, 16" High Back Panels	
84605	Tack Panel, 16" High Back Panels	
84606	Tack Panel, 16" High Back Panels	
84607	Tack Panel, 16" High Back Panels	
84608	Tack Panel, 16" High Back Panels	
84609	Tack Panel, 16" High Back Panels	
84844	Tack Panel, 16" High Back Panels	
84845	Tack Panel, 16" High Back Panels	
84846	Tack Panel, 16" High Back Panels	
84847	Tack Panel, 16" High Back Panels	
84848	Tack Panel, 16" High Back Panels	
12 84849	Tack Panel, 16" High Back Panels	
84850	Tack Panel, 16" High Back Panels	
84324	Tack Panel, 20" High Back Panels	
84325	Tack Panel, 20" High Back Panels	
84326	Tack Panel, 20" High Back Panels	
84327	Tack Panel, 20" High Back Panels	
84328	Tack Panel, 20" High Back Panels	
84329	Tack Panel, 20" High Back Panels	
84330	Tack Panel, 20" High Back Panels	
84331	Tack Panel, 20" High Back Panels	
84332	Tack Panel, 20" High Back Panels	
84333	Tack Panel, 20" High Back Panels	
84334	Tack Panel, 20" High Back Panels	
84335	Tack Panel, 20" High Back Panels	
84336	Tack Panel, 20" High Back Panels	

Parts List

Part Number	Description	Qty.
84337	Tack Panel, 20" High Back Panels	1-4
12 84338	Tack Panel, 20" High Back Panels	
84339	Tack Panel, 20" High Back Panels	
13 86972	Drill Template	1
14 6981X	Channel Filler	2

Workstation Organizers Service Parts List (cont.)

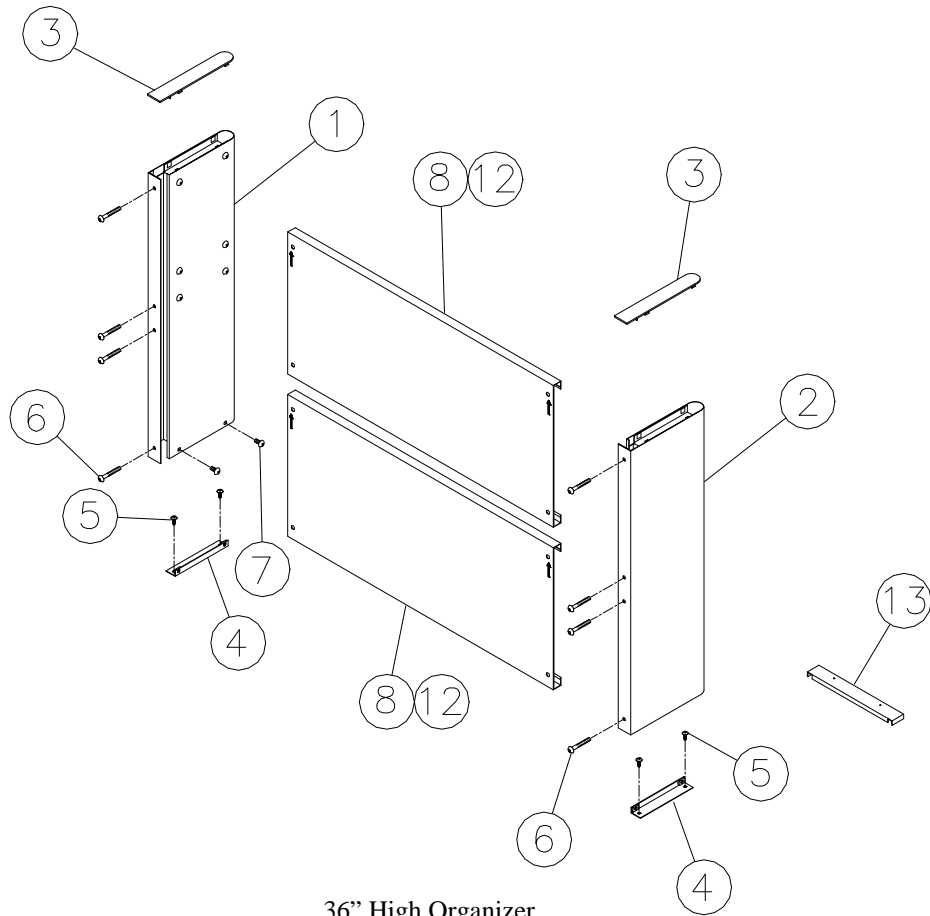

36" High Organizer

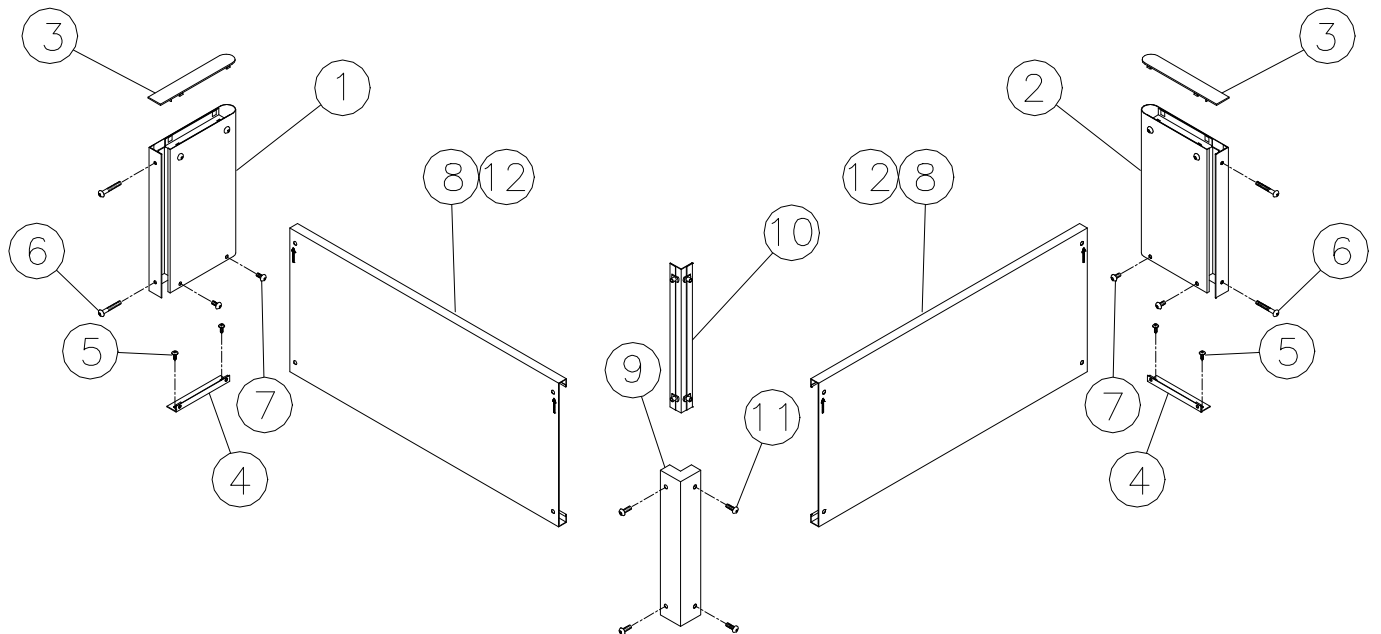

16" High Corner Organizer

technical furniture

Workstation

Organizers Service

Parts List (cont.)

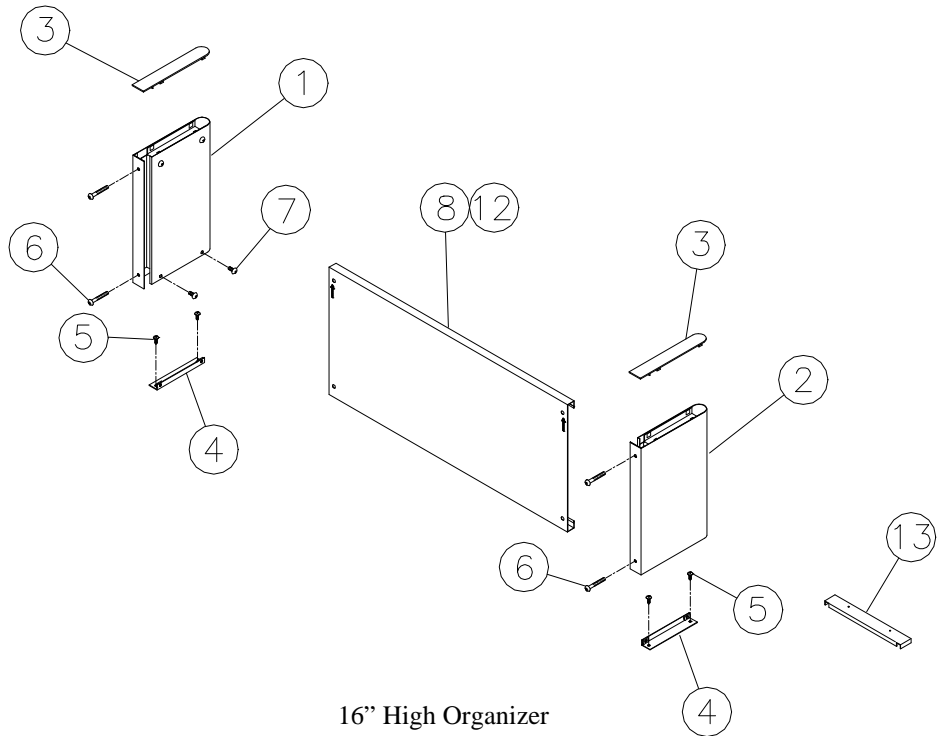

16" High Organizer

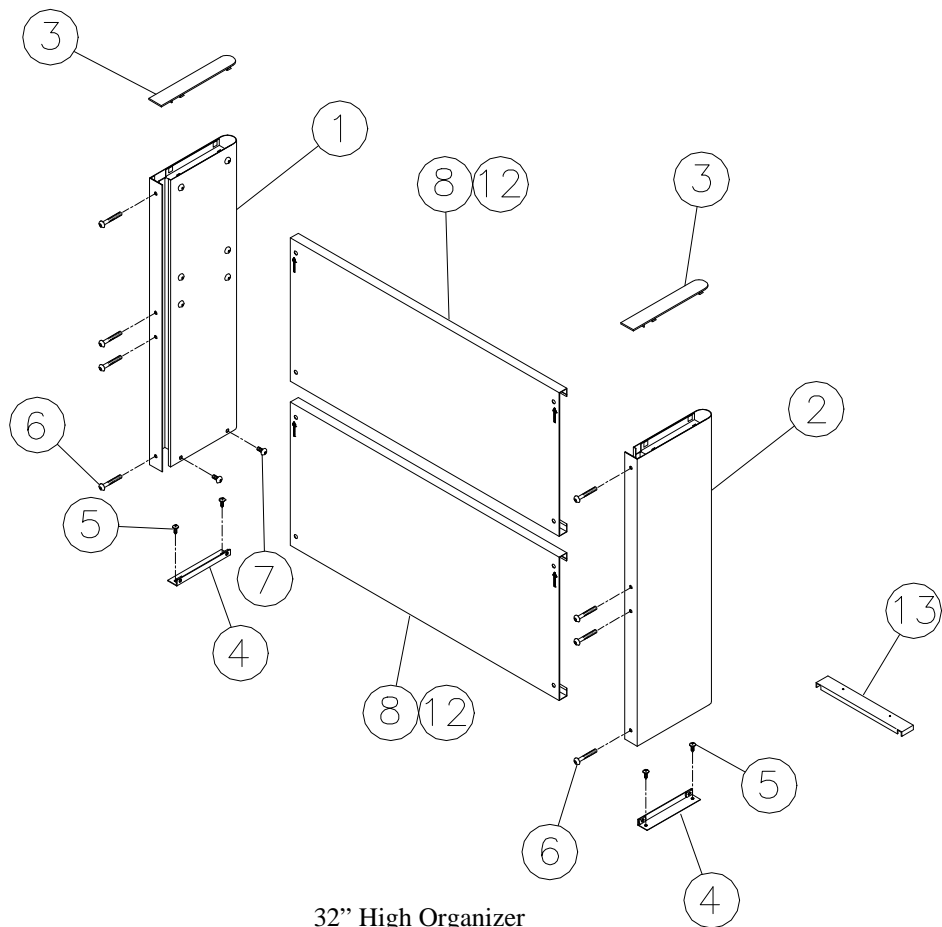

32" High Organizer

technical furniture

Workstation Organizers Service Parts List (cont.)

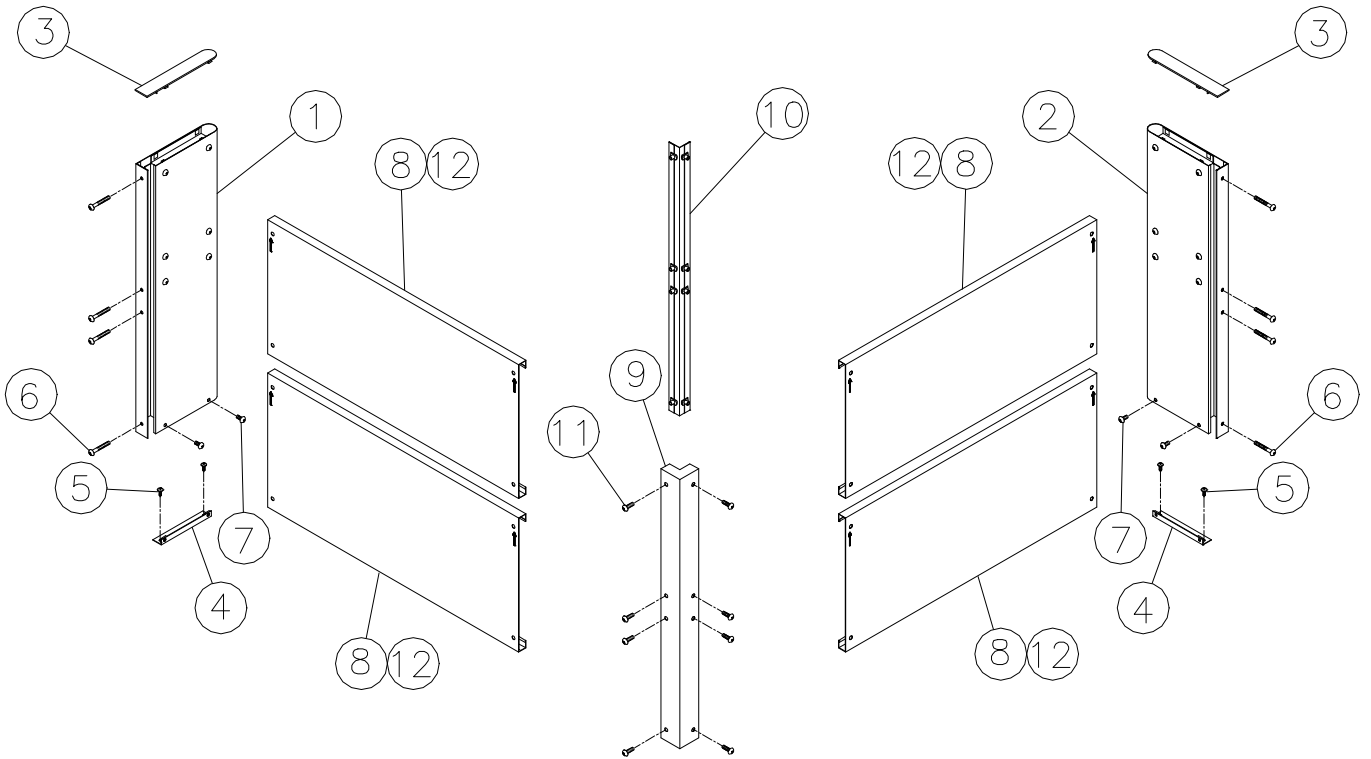

32" High Corner Organizer

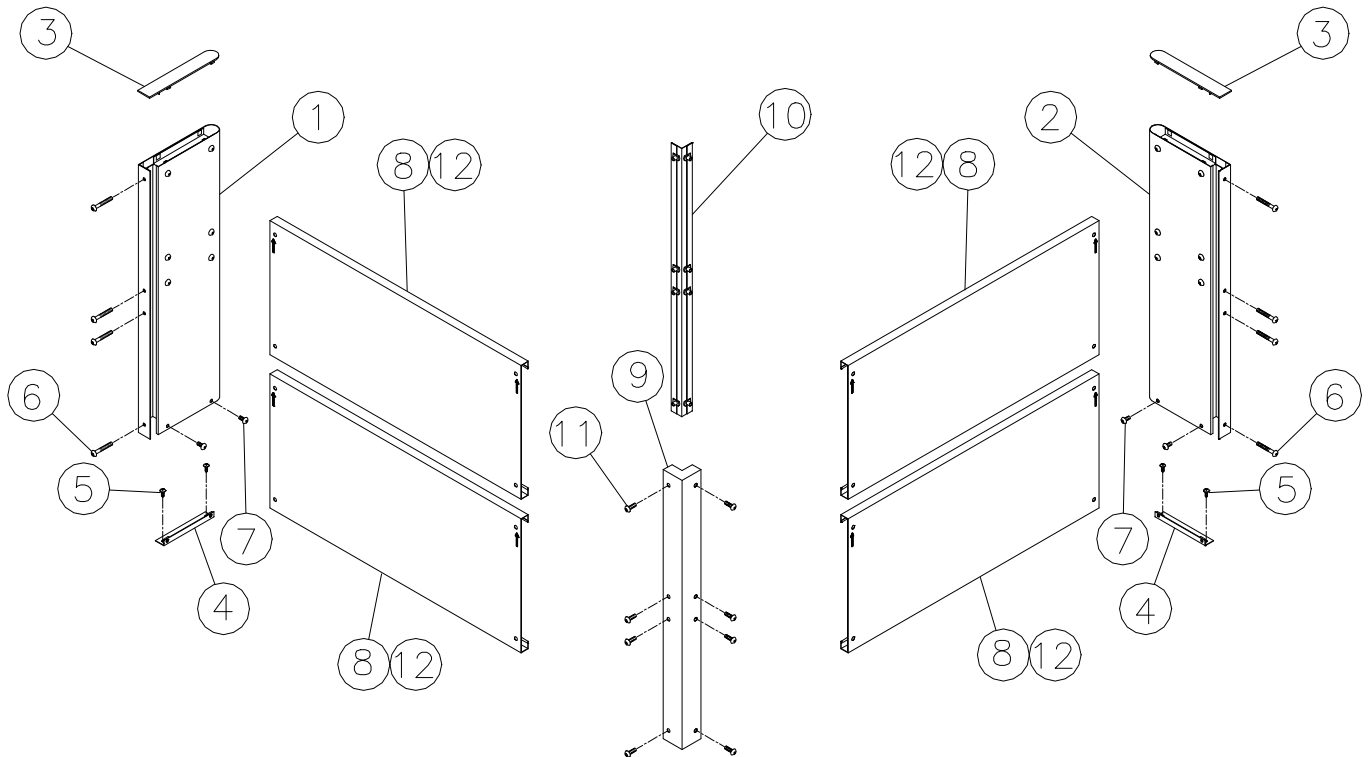

36" High Corner Organizer

technical furniture

Workstation

Organizers Service Parts List (cont.)

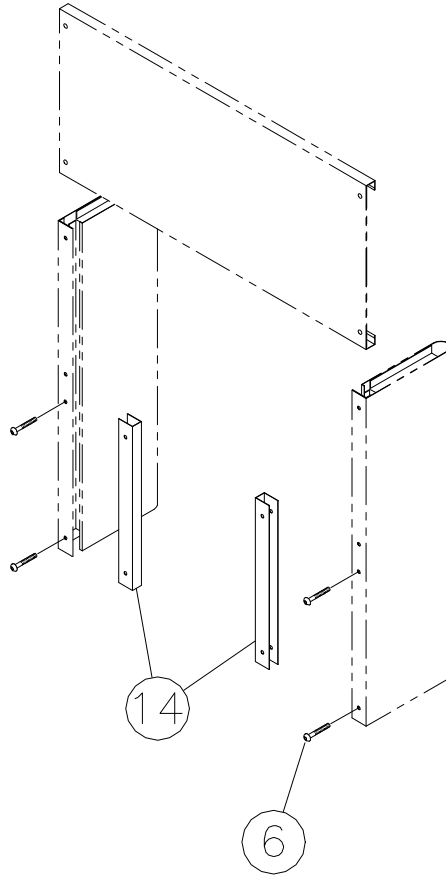

36" High Pass-Through Organizer