



Prices effective February 3, 2025

Published February 2025

Passport Work Table

| | |
|--|---------------|
| Introduction | page 2 |
| Passport Work Table | 3 |
| Tables | 5 |
| Screen | 9 |
| Accessories | 10 |
| Appendices | |
| 20-Day or Less/Assigned Lead-Time Order Information | |
| For the latest materials information, refer to the Materials pages on HermanMiller.com. | |

Introduction

A Note on the Organization of This Book

There are a few signals that will help you understand the organization of this book. Once you know them, you should be able to find your way around easily.

Like a newspaper, this book is formatted with columns of text and illustrations that run vertically.

Information wraps from one column to the next and continues for as many pages as it needs to.

Black bars are clues.

A black bar at the top of a page signals the start of information about a product.

This information is divided into two sections, each signaled by a black bar. Product Information includes a description, additional notes, and dimensional drawings. Specification Information, which always begins at the top of a column, includes a series of steps. Each step represents a decision you need to make in order to complete your product number. Steps must be followed sequentially. The number of pages needed to complete information on a product varies; some will be complete in one page; others may fill three or four pages. Just continue going through the steps until you run into the next product, signaled by the black bar at the top of the page.

Black tabs running along the outside edge of the page help you locate what section you are in or what section you want to go to. You can thumb forwards or backwards to find a section; tabs and text appear on both sides of the page.

The additional pages in the back of the book include the appendices and indices. They are signaled by a long black bar running along the outside edge of the page.

The index is presented two ways.

The first index is in alphabetical order by product name. It can be helpful if you are new to the products and numbering scheme or if you are looking for a type of product, such as work chair or round table.

The second index is by product number. It lists, in alphanumeric order, the base product number, typically a five-digit number.

General Information

This book is effective February 3, 2025, subject to change without notice. Products may be purchased from authorized Herman Miller dealers who will quote prices upon request. For more information about our products and services or to see a list of dealers, visit www.HermanMiller.com.

All prices are list prices. Additional services, such as planning services, design, storage, and installation, are not included and must be added to these prices when the additional services are requested.

Illustrations, specifications, and prices are based on the latest information at the time of publication. The right is reserved to make changes at any time without notice in prices, fabrics, finishes, materials, specifications, and models, and also to discontinue models and finishes.

Dimensions shown in the drawings are engineering drawing dimensions rounded up to the nearest $\frac{1}{8}$ ". Product is shipped set up or knocked down. Products that include "Shipped knocked down" in the description require some assembly. If this statement does not appear in the description, the product is shipped assembled.

Service problems are normally handled by a Herman Miller authorized dealer. Where this cannot be accomplished on a local level, service problems should be referred to the Customer Care Representative for your region, Herman Miller, Inc., Zeeland, Michigan 49464.

20-Day or Less/Assigned Lead-Time Shipments

All products and options in this price book not designated by an Assigned Program icon  will ship in **20 business days or less** after being acknowledged by Herman Miller.

Products and options designated by an  are on the assigned lead-time program and may ship in 20 days, less than 20 days, or more than 20 days from order acknowledgement.

Tables

Screens

Accessories



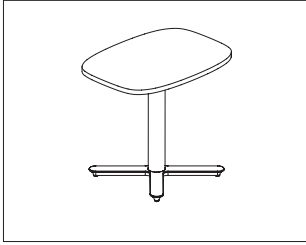

Product Information

Description

This small height-adjustable table has a pneumatic lift to adjust worksurface height between 19" and 31". Worksurface comes in laminate or veneer. Base includes glides.

Notes

- Multi-ply edge available with laminate worksurface only.
- Small table available with glides only.
- Intended to accommodate up to 17½ pounds.
- Adjustment lever location is non-handed.
- Column diameter is 2½".
- Passport work table screen (HJASNNS.) will not work with the small Passport work table.

Dimensions

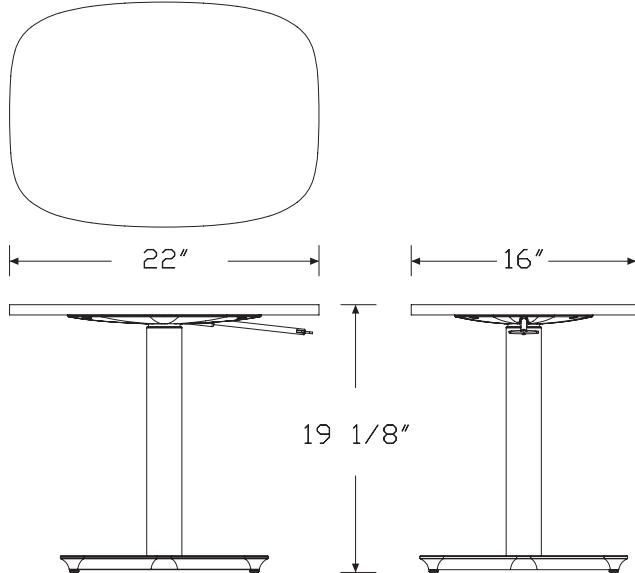

Specification Information

Step 1.

HJAR A

Step 2. Region

NN North America A

Step 3. Edge

S. squared-edge A

Step 4. Depth

16 16" deep A

Step 5. Width

22 22" wide A

Step 6. Casters and Glides

G glides A

Step 7. Surface Material

M thermally fused laminate top/thermoplastic edge A

W veneer top/veneer edge A

Y thermally fused laminate top/multi ply edge A

Prices for Steps 1-7.

| | 22GM | 22GW | 22GY |
|---------------------|-------------|-------------|-------------|
| HJARNN S. 16 | \$1392 | 1645 | 1392 |

Step 8.

Top Finish

For thermally fused laminate top/thermoplastic edge (M)

| | | |
|------------|---|------|
| 8Q | folkstone grey (CP) <input type="checkbox"/> A | +\$0 |
| 91 | white (CP) <input type="checkbox"/> A | +\$0 |
| 98 | studio white (CP) <input type="checkbox"/> A | +\$0 |
| LBA | clear on ash (CP) <input type="checkbox"/> A | +\$0 |
| LBB | oak on ash (CP) <input type="checkbox"/> A | +\$0 |
| LBU | medium matte walnut (CP) <input type="checkbox"/> A | +\$0 |
| UBK | ultra black (CP) <input type="checkbox"/> A | +\$0 |

Top Finish

For thermally fused laminate top/multi ply edge (Y)

| | | |
|-----------|--|------|
| 8Q | folkstone grey (CP) <input type="checkbox"/> A | +\$0 |
| 91 | white (CP) <input type="checkbox"/> A | +\$0 |
| 98 | studio white (CP) <input type="checkbox"/> A | +\$0 |

| Top/Edge Finish | | |
|---------------------------------------|--|--------|
| <i>For veneer top/veneer edge (W)</i> | | |
| ET | clear on ash <input type="checkbox"/> A | +\$100 |
| OU | walnut <input type="checkbox"/> A | +\$100 |
| WHN | natural white oak <input type="checkbox"/> A | +\$100 |

Step 9. Edge Finish

| <i>For thermally fused laminate top/thermoplastic edge (M)</i> | | |
|--|---|------|
| 125 | natural maple (CP) <input type="checkbox"/> A | +\$0 |
| 126 | natural cherry (CP) <input type="checkbox"/> A | +\$0 |
| 127 | walnut (CP) <input type="checkbox"/> A | +\$0 |
| 139 | light ash (CP) <input type="checkbox"/> A | +\$0 |
| 140 | warm ash (CP) <input type="checkbox"/> A | +\$0 |
| 8Q | folkstone grey (CP) <input type="checkbox"/> A | +\$0 |
| 91 | white (CP) <input type="checkbox"/> A | +\$0 |
| 98 | studio white (CP) <input type="checkbox"/> A | +\$0 |
| LBA | clear on ash (CP) <input type="checkbox"/> A | +\$0 |
| LBB | oak on ash (CP) <input type="checkbox"/> A | +\$0 |
| LBU | medium matte walnut (CP) <input type="checkbox"/> A | +\$0 |

| <i>For thermally fused laminate top/multi ply edge (Y)</i> | | |
|--|---|-------|
| PDG | multi ply edge <input type="checkbox"/> A | +\$60 |

Step 10. Leg/Foot Finish

| | | |
|-----|--|-------|
| 8Q | folkstone grey (CP) <input type="checkbox"/> A | +\$0 |
| 98 | studio white (CP) <input type="checkbox"/> A | +\$0 |
| BK | black <input type="checkbox"/> A | +\$0 |
| DB3 | glacier <input type="checkbox"/> A | +\$65 |
| DN2 | nightfall <input type="checkbox"/> A | +\$65 |
| DR1 | canyon <input type="checkbox"/> A | +\$65 |
| OLF | olive <input type="checkbox"/> A | +\$65 |
| UBK | ultra black (CP) <input type="checkbox"/> A | +\$0 |

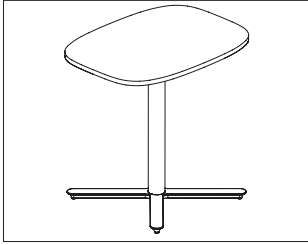

Product Information

Description

This large height-adjustable table has a pneumatic lift to adjust worksurface height from 25½" to 43½" with glides or 27" to 45" with casters. Worksurface comes in laminate or veneer.

Notes

- Multi-ply edge available with laminate worksurface only.
- Casters (G) option comes with 4 locking casters.
- Casters or glides can be changed in the field which will change the overall height of the table.
- Intended to accommodate up to 22 pounds.
- Adjustment lever location is non-handed.
- Column diameter is 2½".
- Order Passport work table screen (HJASNNS.) separately. Table surface has predrilled holes on the underside for screen attachment.

Dimensions

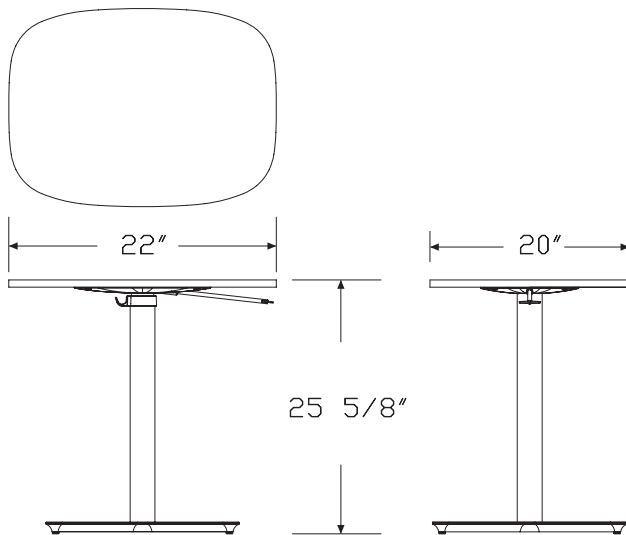

Specification Information

Step 1.

HJAL A

Step 2. Region

NN North America A

Step 3. Edge

S. squared-edge A

Step 4. Depth

20 20" deep A

Step 5. Width

27 27" wide A

Step 6. Casters and Glides

C casters A

G glides A

Step 7. Surface Material

M thermally fused laminate top/thermoplastic edge A

W veneer top/veneer edge A

Y thermally fused laminate top/multi ply edge A

Prices for Steps 1-7.

| | 27CM | 27CW | 27CY | 27GM | 27GW | 27GY |
|--------------|--------|------|------|------|------|------|
| HJALNN S. 20 | \$1772 | 2025 | 1772 | 1747 | 1999 | 1747 |

Step 8.

Top Finish

For thermally fused laminate top/thermoplastic edge (M)

| | | |
|-----|---|------|
| 125 | natural maple (CP) <input type="checkbox"/> A | +\$0 |
| 126 | natural cherry (CP) <input type="checkbox"/> A | +\$0 |
| 127 | walnut (CP) <input type="checkbox"/> A | +\$0 |
| 139 | light ash (CP) <input type="checkbox"/> A | +\$0 |
| 140 | warm ash (CP) <input type="checkbox"/> A | +\$0 |
| 8Q | folkstone grey (CP) <input type="checkbox"/> A | +\$0 |
| 91 | white (CP) <input type="checkbox"/> A | +\$0 |
| 98 | studio white (CP) <input type="checkbox"/> A | +\$0 |
| LBA | clear on ash (CP) <input type="checkbox"/> A | +\$0 |
| LBB | oak on ash (CP) <input type="checkbox"/> A | +\$0 |
| LBU | medium matte walnut (CP) <input type="checkbox"/> A | +\$0 |

Passport Work Table, Large *continued*

Passport Tables

Top Finish

For thermally fused laminate top/multi ply edge (Y)

| | | |
|-----------|--|------|
| 8Q | folkstone grey (CP) <input type="checkbox"/> A | +\$0 |
| 91 | white (CP) <input type="checkbox"/> A | +\$0 |
| 98 | studio white (CP) <input type="checkbox"/> A | +\$0 |

Top/Edge Finish

For veneer top/veneer edge (W)

| | | |
|------------|--|--------|
| ET | clear on ash <input type="checkbox"/> A | +\$100 |
| OU | walnut <input type="checkbox"/> A | +\$100 |
| WHN | natural white oak <input type="checkbox"/> A | +\$100 |

Step 9. Edge Finish

For thermally fused laminate top/thermoplastic edge (M)

| | | |
|------------|---|------|
| 125 | natural maple (CP) <input type="checkbox"/> A | +\$0 |
| 126 | natural cherry (CP) <input type="checkbox"/> A | +\$0 |
| 127 | walnut (CP) <input type="checkbox"/> A | +\$0 |
| 139 | light ash (CP) <input type="checkbox"/> A | +\$0 |
| 140 | warm ash (CP) <input type="checkbox"/> A | +\$0 |
| 8Q | folkstone grey (CP) <input type="checkbox"/> A | +\$0 |
| 91 | white (CP) <input type="checkbox"/> A | +\$0 |
| 98 | studio white (CP) <input type="checkbox"/> A | +\$0 |
| LBA | clear on ash (CP) <input type="checkbox"/> A | +\$0 |
| LBB | oak on ash (CP) <input type="checkbox"/> A | +\$0 |
| LBU | medium matte walnut (CP) <input type="checkbox"/> A | +\$0 |

For thermally fused laminate top/multi ply edge (Y)

| | | |
|------------|---|-------|
| PDG | multi ply edge <input type="checkbox"/> A | +\$60 |
|------------|---|-------|

Step 10. Leg/Foot Finish

| | | |
|------------|--|-------|
| 8Q | folkstone grey (CP) <input type="checkbox"/> A | +\$0 |
| 98 | studio white (CP) <input type="checkbox"/> A | +\$0 |
| BK | black <input type="checkbox"/> A | +\$0 |
| DB3 | glacier <input type="checkbox"/> A | +\$65 |
| DN2 | nightfall <input type="checkbox"/> A | +\$65 |
| DR1 | canyon <input type="checkbox"/> A | +\$65 |
| OLF | olive <input type="checkbox"/> A | +\$65 |
| UBK | ultra black (CP) <input type="checkbox"/> A | +\$0 |

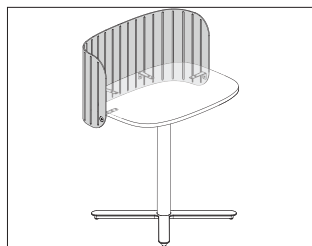

Product Information

Description

This work table screen attaches to a Passport large work table. Attachment position allows for a 7/8" gap along back edge of table surface for cord drop. Screen is not tackable.

Notes

Screen does not work with Passport small work table (HJARNNS.).

Screen attachment brackets align with predrilled holes on underside of work surface.

Screen is 1/4" thick and extends 3 1/2" below and 9" above the worksurface.

Dimensions

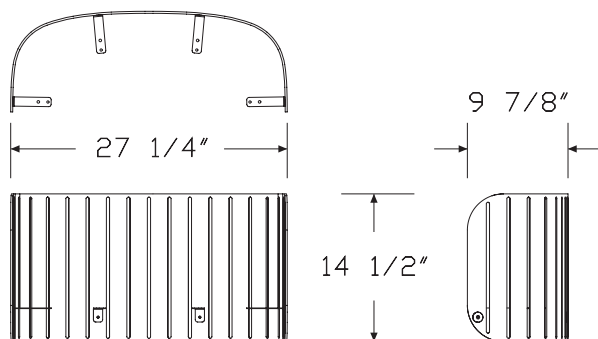

Specification Information

Step 1.

HJAS A

Step 2. Region

NN North America A

Step 3. Attachment Method

S. attached on outside of work surface A

Step 4. Height

42 42" high A

Step 5. Width

27 27" wide A

Step 6. Material

F felt A

Prices for Steps 1-6.

| | |
|---------------------|--------------|
| | 27F |
| HJASNN S. 42 | \$783 |

Step 7. Material Finish

Price Category 4 +\$0

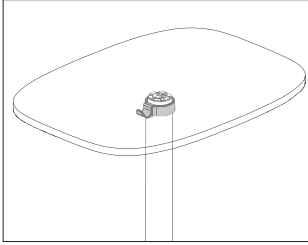

Passport Accessories

Product Information

Description

This optional bag hook is intended for use on the Passport large work table. The 2-piece hook snaps around the column beneath the worksurface and is easily added or removed by the user.

Notes

Hook finishes available in same finish options as table base.

Dimensions

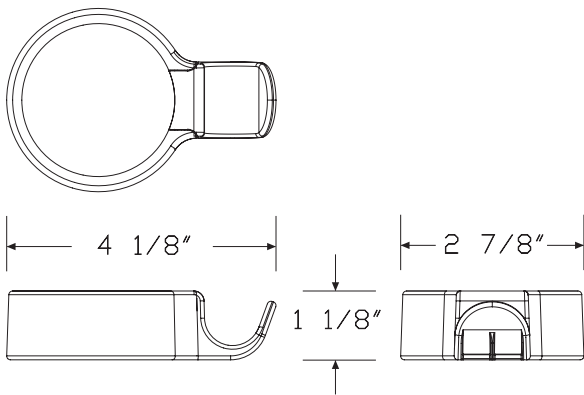

Specification Information

Step 1.

HJAH

Step 2. Region

NN North America

Prices for Steps 1-2.

HJAHNN \$26



Step 3. Material Finish

| | | |
|------------|--|-------|
| 8Q | folkstone grey (CP) <input type="checkbox"/> | +\$0 |
| 98 | studio white (CP) <input type="checkbox"/> | +\$0 |
| BK | black <input type="checkbox"/> | +\$0 |
| DB3 | glacier <input type="checkbox"/> | +\$10 |
| DN2 | nightfall <input type="checkbox"/> | +\$10 |
| DR1 | canyon <input type="checkbox"/> | +\$10 |
| OLF | olive <input type="checkbox"/> | +\$10 |
| UBK | ultra black (CP) <input type="checkbox"/> | +\$0 |

20-Day or Less/Assigned Lead-Time Order Information

20-Day or Less and Assigned Lead-Time Programs

20-day or less and assigned lead-time products are designed for established Herman Miller dealers with pre-approved credit.

Products are distributed from multiple manufacturing facilities across the United States. All products and options not designated by an Assigned Lead-Time icon  will ship in 20 business days or less after being acknowledged by Herman Miller. Products and options designated by an  are on the assigned lead-time program and will ship in 20 days, less than 20 days, or more than 20 days from order acknowledgement.

Ordering Procedure

Please place orders through Order Manager. If this is not available to you, place orders through mail or fax. Verbal purchase orders will not be accepted.

Order Entry fax number for Meridian®

Filing and Storage: (616) 846 9236.

Order Entry fax number for all other products:

(616) 654 3085.

For more information, contact your Customer Care representative at:
(866) 854 3048 ext 3400.

Shipments and Delivery

Per Herman Miller Terms and Conditions.

Changes and Cancellation

Per Herman Miller Terms and Conditions.

For more information about our products and services or to see a list of dealers, please visit us at HermanMiller.com or call (800) 851 1196.

© 2025 Herman Miller, Inc., Zeeland, Michigan

Distribution Rights

Working together since 1956, Herman Miller and Vitra are the authentic sources of designs by Charles and Ray Eames, Alexander Girard, and George Nelson. All the designs shown in this book are protected by law. Herman Miller has obtained all rights to make and sell these designs. Also, Herman Miller holds exclusive worldwide manufacturing and distribution rights for these products with the following exceptions:

Charles and Ray Eames, George Nelson, and Alexander Girard—Worldwide distribution rights for furniture in all areas except Europe and the Middle East. For those areas, please contact Vitra.

Isamu Noguchi—Worldwide distribution rights for the Noguchi Rudder Table. Distribution rights for the Noguchi Table in North America and Central America only. For all other areas, please contact Vitra.

Magis—Exclusive distribution rights in the US and Canada. For all other areas, please contact Magis.

© HermanMiller, 3D Intelligent, 8Z Pellicle, AO, Action Office, Aeron, Aside, Bubble Lamps, Canvas Office Landscape, Caper, Celle, Cosm, Co/Struc, Daisyone, Distil, Eames, Eco-Dematerialized, Embody, Envelop, Ethospace, Exclave, Fine-Tune, FlexFront, Flo, Formcoat, Formwork, Ground Cloth, Intent, Kinemat, Layout Studio, Lino, Live Unframed, Living Office, Maharam, Meridian, Mirra, Motia, Nelson, Pari, Pellicle, Perspectives, Plex, PostureFit, PostureFit SL, Public Office Landscape, Sayl, Setu, Striad, Tu, Ubi, Verus, Wishbone, Y-Tower and Zeph are among the registered trademarks of Herman Miller, Inc., and its owned subsidiaries.

™ About Face, AireWeave, Airia, Ambit, Asari Chair by HermanMiller, Backfit, Bubbletack, Burdick Group, Butterfly Back, Canvas Vista, Cellular Suspension, Commend, Compass, Connect, DOT, Duracare, Durawrap, EnhancedAccess, Everywhere, Flex-Edge, Flute, Harmonic, Headway, Herman Miller Select, Hopsak 2, Iota, Keyless Entry, Latitude, Logic Mini, Logic Power Access Solutions, Lyris, Lyris 2, Made-to-Measure Storage, Mora, Multiscrim, Nevi, OE1, OE1 Workspace Collection, Overlay, Pixelated Support, Pronta, Renew, Sense, Soft Pad, Stackable, Stackable Storage, Swoop, Thrive, Tone, TriFlex, Twist and Wireframe are among the trademarks of Herman Miller, Inc., and its owned subsidiaries.

SM Herman Miller Options is among the service marks of Herman Miller, Inc.

AAP™ is a trademark of Extron Electronics.

Alexander Girard® is a registered trademark of The Alexander Girard Estate.

Chemsur® is a registered trademark of Wilsonart International.

Corian® is a registered trademark of E. I. du Pont de Nemours and Company Corporation.

Crypton® is a registered trademark of Crypton, Inc.

DACRON® is a registered trademark of INVISTA S.a r.l.

Danzer® is a registered trademark of Danzer Holding AG.

Decora® is a registered trademark of Leviton Manufacturing Co., Inc.

Edelman® Leather is a registered trademark of Edelman Leather, Inc.

Extron® is a registered trademark of RGB Systems, Inc.

FENIX NTM® is a registered trademark of Arpa Industriale S.p.A.

FLEXNET™ is a trademark of Milliken & Company.

Floor Saver Glide® is a registered trademark of Carpin Manufacturing, Inc.

Forest Stewardship Council® is a registered trademark of the Forest Stewardship Council A.C. (FSC). We are FSC® certified (FSC® C102895).

FSC® is a registered trademark of the Forest Stewardship Council A.C. (FSC).

Geiger® is a registered trademark, and Bumper™, Saiba™, and Ward Bennett™ are trademarks, of Geiger International.

Hang-It-All® is a registered trademark of Lucia Eames Demetrios, d.b.a. Eames Office.

Holophane® is a registered trademark of Holophane.

Ingeo™ is a trademark of Cargill Dow LLC.

iPad® and Mac mini® are registered trademarks of Apple Inc.

Leviton® is a registered trademark of Leviton Manufacturing Co., Inc.

LifeSize® is a registered trademark of LifeSize Communications, Inc.

Lisocore® is a registered trademark of Pyrus Panels GmbH.

Logitech G® is a registered trademark of Logitech International S.A.

Magis®, Bombo®, and Me Too® are registered trademarks of Magis S.p.A.

MicrobeCare™ is a trademark of Parasol Medical LLC.

Microsoft® and Natural® Keyboard are registered trademarks of Microsoft Corporation.

Noguchi® and the Noguchi table configuration (trade dress) are registered trademarks, and Rudder Table™ is a trademark, of The Isamu Noguchi Foundation and Garden Museum.

Place Textiles® is a registered trademark of Place Textiles.

Sunbrella® is a registered trademark of Glen Raven, Inc.

SuperSeat™ is a trademark of Dahti Seating, a division of ITW.

Valor™ is among the trademarks owned by Nemschoff, Inc.