

# PRODUCT SPECIFICATIONS ■

## Strive® High-Density Sled Base Stack Chair & Stool

March 2023

### TECHNICAL SPECIFICATIONS

#### Seat

Injection-molded polypropylene seat.

#### Backrest

Injection molded polypropylene with integral steel cantilever springs. The combination of the slotted polypropylene back and the spring steel provides a supportive flexing back. Springs are nominal 4.5 mm diameter chrome silicon valve spring wire. Top of backrest has an integral handle for ease of lifting and stacking.

#### Optional Glides

Ganging and non-ganging glides snap on the wire frame and are held in location with ribs that nest into slots that are pressed into the wire frame. Ganging glides (2-male and 2-female) slide together, allowing multiple chairs to be connected in a line. Glides include: Polycarbonate - injection-molded clear hard plastic; PVC non-skid glide - Extruded hard PVC upper with a soft PVC layer on the bottom (black); Steel glide - injection-molded clear polycarbonate upper with a stainless steel insert molded in the bottom. Felt Glide - clear polycarbonate upper with replaceable (snap-fit) cap. Cap is black nylon with neutral-colored felt.

#### Chair & Stool Frames & Finishes

$\frac{7}{16}$ " solid steel rod, all joints welded. Finished in bright nickel-chrome or with electrostatically-applied epoxy powder-coat paint.

#### Optional Upholstered Seat

Molded urethane foam (soy based) is attached to an injection-molded polypropylene seat board, then upholstered using a draw-string process. The assembled seat pad is attached to the seat by means of hidden fasteners. Note: upholstered seat is required with translucent poly backs.

#### Transport Dolly

Tubular and plate steel welded together. 5" casters: two fixed, two swivel. Powder-coated finish.



### CODE COMPLIANCE



## DIMENSIONS

Strive High-Density Sled Base Chair -  
Polypropylene Seat & Backrest

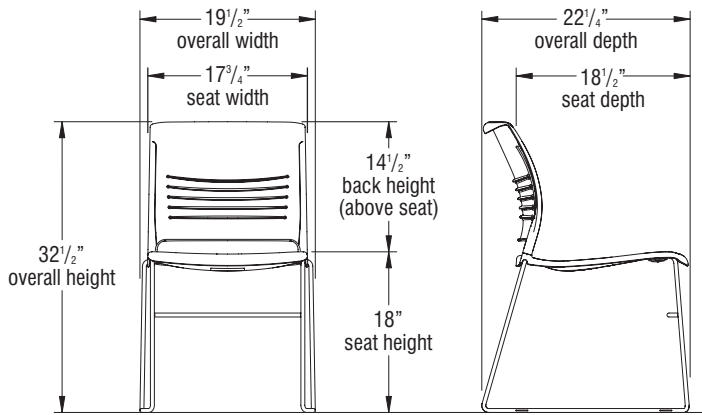

Strive High-Density Sled Base Chair -  
Upholstered Seat & Polypropylene Backrest

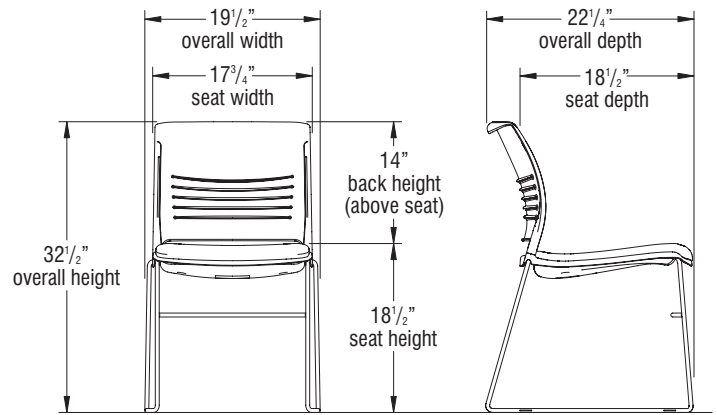

Strive High-Density 24" Sled Base Stool -  
Polypropylene Seat & Backrest

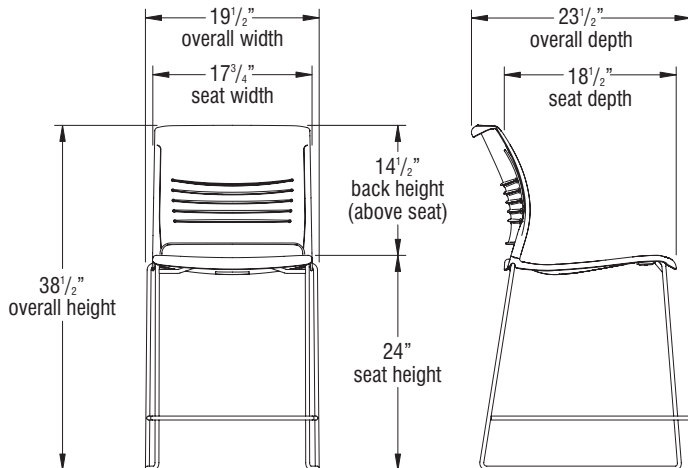

Strive High-Density 24" Sled Base Stool -  
Upholstered Seat & Polypropylene Backrest

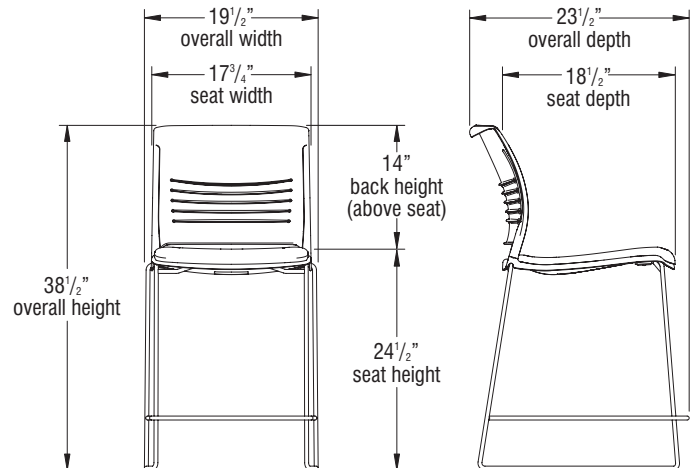

Strive High-Density 30" Sled Base Stool -  
Polypropylene Seat & Backrest

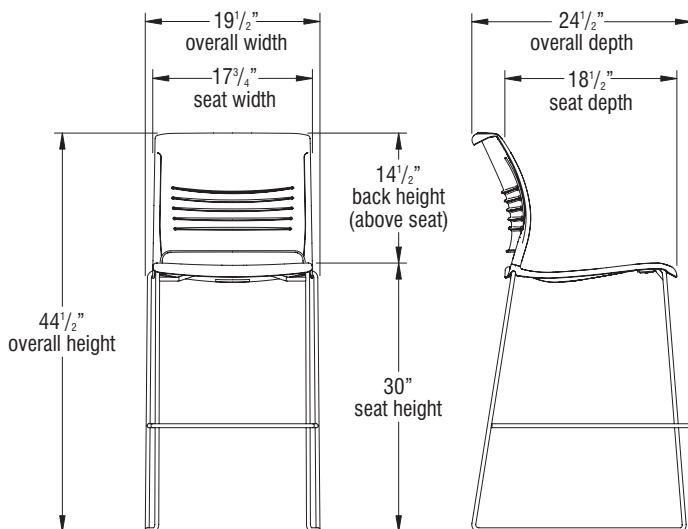

Strive High-Density 30" Sled Base Stool -  
Upholstered Seat & Polypropylene Backrest

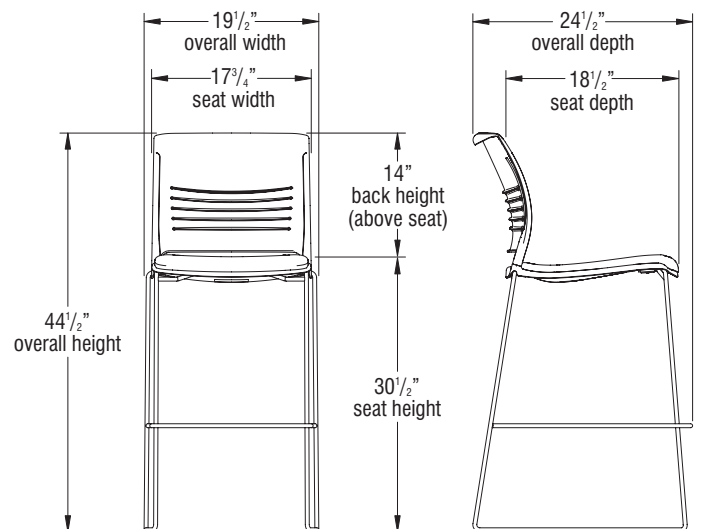

## STATEMENT OF LINE

All models are available in polypropylene seat/backrest or upholstered seat/polypropylene backrest.

### Strive High-Density Sled Base Stack Chair

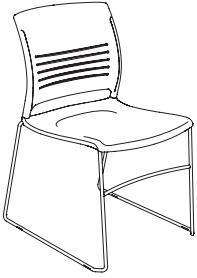

SWNA

### Strive High-Density Sled Base Stack Stools

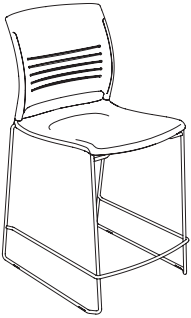

SWSNAP24

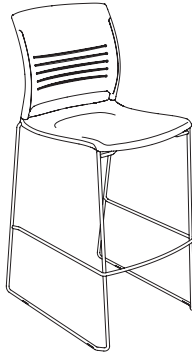

SWSNAP30

## CODE COMPLIANCE

