



TORSION AIR[®] SEATING

PRICE LIST

EFFECTIVE MAY 9, 2025
800.424.2432



Ordering Customer's Own Material (C.O.M.) Upholstery	
Information	3

Torsion Air® Nesting Chairs	
General Information	4
Technical Specifications	5
Color Options	6
Torsion Air® Nesting Chairs	7

Torsion Air® Stack Chairs	
General Information	9
Technical Specifications	10
Color Options	11
Torsion Air® Stack Chairs	12
Torsion Air® Dolly	14

Torsion Air® Task Seating	
General Information	15
Technical Specifications	16
Color Options	17
Chairs	18
Stools	19



How to Specify

As a standard procedure, KI applies seating upholstery as swatched by the textile distributor. Reference distributor's website. Upholstery that is required to be applied differently than is swatched, will need a Product Modification Request written specifying the direction the upholstery is to be applied.

Seating upholstery requiring specific positioning of intricate patterns or patterns repeats on seats and backrests, will need a Product Modification Request written including a sketch noting the specific requirements, as in Diagram A.

Diagram A

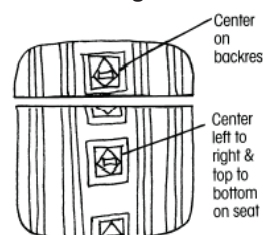

When directional or patterned fabrics are used, they often require more yardage than solid colors.

C.O.M. must be supplied in continuous yardage.

C.O.M. yardage requirements accompanying products in the pricing section are for 10 chairs/seats or less, 54" wide nondirectional material. On larger orders, less material is required.

Leather hides must be a minimum of 50 square feet of usable material. The outer edges cannot be calculated as square feet or yardage. To determine square footage, multiply unit yardage by 18 square feet to obtain the total square footage required per unit.

For exact production yardage requirements, call 1-800-424-2432, ext. 2707.

Production

Customer's upholstery must be approved prior to acceptance for production.

C.O.M. not received into the appropriate facility 3 weeks prior to acknowledged delivery date may go on hold. See KI C.O.M. Shipping Location listing for the correct facility address by product.

Testing

When KI requires testing, actual yardage to upholster one chair may be required. The C.O.M. Specialist will confirm model and fabric testing requirements when applicable.

Approved test samples will be applied to the order or will be held for 6 months. After 6 months, the sample will no longer be applied to your order. For all product testing, send fabric samples to the manufacturing facility. See KI C.O.M. Shipping Location listing for the correct facility address by product.

All C.O.M. must be labeled with the KI product order number and customer purchase order number.

Treated Materials

If C.O.M. requires processing such as a stain resistance treatment or acrylic backing, it may shrink. To prevent delays in delivery or back ordering due to shrinkage, please have your processor verify measurement after processing and assure adequate yardage shipped.

Split Orders

If a portion of the shipment which does not require C.O.M. application is to be processed and shipped early, KI will enter the order immediately at your request. These split shipments are subject to minimum order changes.

Excess Upholstery Material

KI will dispose of excess upholstery material at the time of shipment unless expressly requested to return it with the product shipment.

Cancelled or Changed Orders

KI assumes no responsibility for extra C.O.M. due to a change of upholstery or cancellation of an order. If it the customer's responsibility to arrange for return of the material.

Contact the C.O.M. Specialist at 1-800-424-2432, ext. 2707, with questions or to request a split order.

C.O.M. SHIPPING LOCATION

Architectural Walls Evoke..... MN Genius..... MN Casegoods Aristotle.....MN Likha.....MN Classroom Furniture Cogni GB Intellect Wave GB Learn2.....GB Ruckus..... GB Desking 700 Series KP Balance MN Genesis MN True KP Universal MN WorkZone MN Files & Storage 700 Series.....GB Connection.....BW U-Series..... GB Tattoo.....BW Fixed Seating Concerto.....BW Single Pedestal GB Jury Base GB Lancaster.....BW Sequence GB University GB	Panel Systems All Terrain.....KP Balance MN Universal MN Wireworks MN Unite..... MN Residence Hall Furniture RoomScape..... MN Screens All Terrain.....KP Connection Zone.....BW Tribulaire.....BW True/Volition KP Genesis.....KP Tattoo..... MN Universal.....BW Seating 600 Series.....BW Affina HN Altus GB Apply GB Calida HN CaschaVT Clamber HN Cogni GB Diem OM Doni GB GladlyVQ Grazie GB Hub HN Impress OM Impress Ultra OM	Intellect Wave GB Jessa HN JubileeVQ Katera..... GB Kurv Benches..... HN Learn2.....GB LimeLite..... GB Lyra HN Medical & Laboratory Stools..... OM MyPlace HN MyWay HN Oath GB Opt4..... GB Pilot OM Promenade BW Ruckus..... GB Sela HN Sift GB Signia..... OM Soltice Metal HN Soltice..... HN Sonrisa HN Strive..... GB Sway BW Tattoo..... HN Torsion-on-the-Go! GB Torsion Air GB Zeker HN Zoetry HN
--	--	--

KI C.O.M. Manufacturing Site Addresses:

BW KI Bonduel Attn: COM Storage 204 West South St. Bonduel, WI 54107	HN KI High Point Attn: COM Storage 217 Feld Avenue High Point, NC 27263	MN KI Manitowoc Attn: COM Storage 1400 S. 41st St. Manitowoc, WI 54220	VQ KI Attn: COM Fabrics 6892 Marlin Circle La Palma, CA 90623
GB KI Green Bay Attn: COM Storage 1687 Westminster Drive - Gate 3 Green Bay, WI 54302	KP KI Pembroke Attn: COM Storage 1000 Olympic Dr. Pembroke, Ontario K8A6X7	OM KI Attn: COM Storage 1100 S. Mildred Ave. Ontario, CA 91761	VT KI Attn: COM Storage 2803 South Taylor Drive Sheboygan, WI 53081

Torsion Air™ Nesting Chairs

General Information



Torsion Air™ Nesting Chairs

General Information



Armless Chair
(TANNA)



Arm Chair
(TANWA)



Piretti Tablet
Arm Chair
(TANTARPT)



Flip-up Tablet
Arm Chair
(TANTARFD)

Features				
Back flex	•	•	•	•
Flip-up seat	•	•	•	•
Nesting	•	•	•	•
Casters	•	•	•	•
General Dimensions				
Seat width	17"	17"	17"	17"
Seat depth	18-1/2"	18-1/2"	18-1/2"	18-1/2"
Seat height	18"	18"	18"	18"
Back width	17"	17"	17"	17"
Back height	16"	16"	16"	16"
Overall Dimensions				
Width	23-7/8"	23-7/8"	25"	27"
Depth	24-1/4"	24-1/4"	30-1/4"	31"
Height	33-1/2"	33-1/2"	33-1/2"	33-1/2"
Top of arm to floor		24-7/8"	28-1/2"	28"
Depth of nesting (two chairs)	28"	28"	34"	35"
Depth of each additional chair	7-1/2"	7-1/2"	7-1/2"	7-1/2"

INFORMATION

C.O.M. Testing and Production Requirements

Not all materials are suitable for upholstering this product. A 1 yd. x 54" sample must be submitted and approved prior to acceptance of an order. If the fabric is directional in pattern or weave, the direction must be indicated on the submitted sample, and additional yardage may be requested.

Test samples must be sent to:

KI
Attn: C.O.M. Specialist
1687 Westminster Drive - Gate 3
Green Bay, WI 54302

Fabric Disclaimer

Fabric will be applied as swatched by the fabric manufacturer. Fabric that is required to be applied differently than is swatched will need a Modified Product Request written specifying the direction the fabric is to be applied.

KI Color Match Program

KI offers the additional option of color matching paint, polypropylene, or wood stain through Product Modification Requests. Contact Customer Service for details.

Whatever you imagine, whatever you require, KI's Color Match program lets you pick your color!

Color Match Process - Poly Seating Information can be found here.

INFORMATION

Warranty

Refer to KI Terms & Conditions document or visit ki.com



Seat and Backrest

Seat is two-piece construction of molded plywood upholstery board with a molded compound curved polypropylene shroud with a textured finish. Seat is always upholstered. Foam (1 3/4") is applied to the molded plywood upholstery board. Fabric is then upholstered over the foam. Backrest frame is molded glass-reinforced nylon. Mesh fabric is 100% polyester. Backrest has an integral "handle".

Seat flips up to allow chairs to nest for storage and transport.

Seat and back are field replaceable.

Backrest Supports

Two welded steel backrest supports attach the backrest to the torsion mechanism.

Torsion Mechanism

The back flex is achieved by the torsion mechanism. It consists of two flat torsion springs captured at both ends by steel bushings that are welded to the backrest supports. The torsion mechanism creates gradually increasing resistance over the full 12° of back flex.

Flip-and-Fold Tablet

Available on RH or LH side. The tablet support is 1 3/16" O.D. x 14-gauge round steel tubing. The support is welded to the chair frame. The tablet mechanism consists of two die cast aluminum housings and a stamped steel hinge assembly. The main housing is mounted inside the steel support tube and secured with a thread-forming screw. The mechanism has two through-bolted pivot axes with bushing that allow stowing. The mechanism permits 12° of horizontal rotation for ingress/egress without stowing the tablet. With the tablet stowed, the chair will nest with other Torsion Air chairs with or without tablets. The tablet is made from blow-molded high-density polyethylene and is only available in black. The tablet is connected to the mechanism and supported by a 12-gauge steel plate. The tablet has an effective working surface 12" deep by 16" across.

Basic Flip-Up Tablet

Available on RH or LH side. The tablet arm support structure is 1" diameter, 13-gauge tubing, welded to the main chair frame. A formed steel hinge is welded to the top of the support structure and secured with screws to the underside of the writing surface. Writing surface is nominally 9 1/2" x 20 3/4" x 12 1/2" plywood core of 5/8" thick, 11-ply hardwood, surfaced with 0.030" high-pressure laminate top and plain backer undersurface. Edges are lacquered and sealed. When so equipped, and with the tablet flipped up, chairs will nest with other Torsion Air chairs with tablets, or without.

Frame

The frame is made up of four legs welded to a steel mechanism tube. The legs are 1" diameter, 13-gauge high-strength low alloy steel tubing.

Arms

Armrests are made of polypropylene. Armrests rotate with the back. Armrests are field replaceable.

Leg Finishes

Legs are finished in either baked-on electrostatically-applied 45-sheen powder-coat paint, or bright nickel-chrome plating.

Casters/Glides

Double wheels (60 mm) of high-impact thermoplastic. High-impact plastic frame. Caster is always black. Bell glide (2" high) made of high-impact plastic also available, black only.

DIMENSIONS

Torsion Air Armless Chair

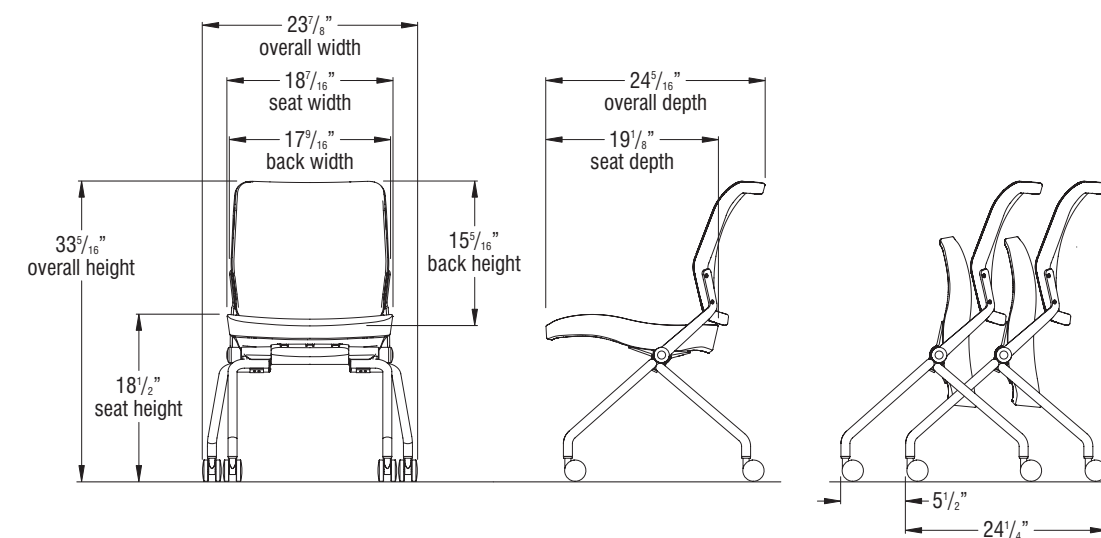

Nesting Footprint Calculation: Overall Length of a Row = 24.25" (1 chair) + 5.5" (additional chairs)

Examples: 2 Chairs: 24.25" (1 chair) + 5.5" (1 chair) = 29.75"

16 Chairs: 24.25" (1 chair) + 5.5" (15 chairs) = 106.75"

Torsion Air Armchair

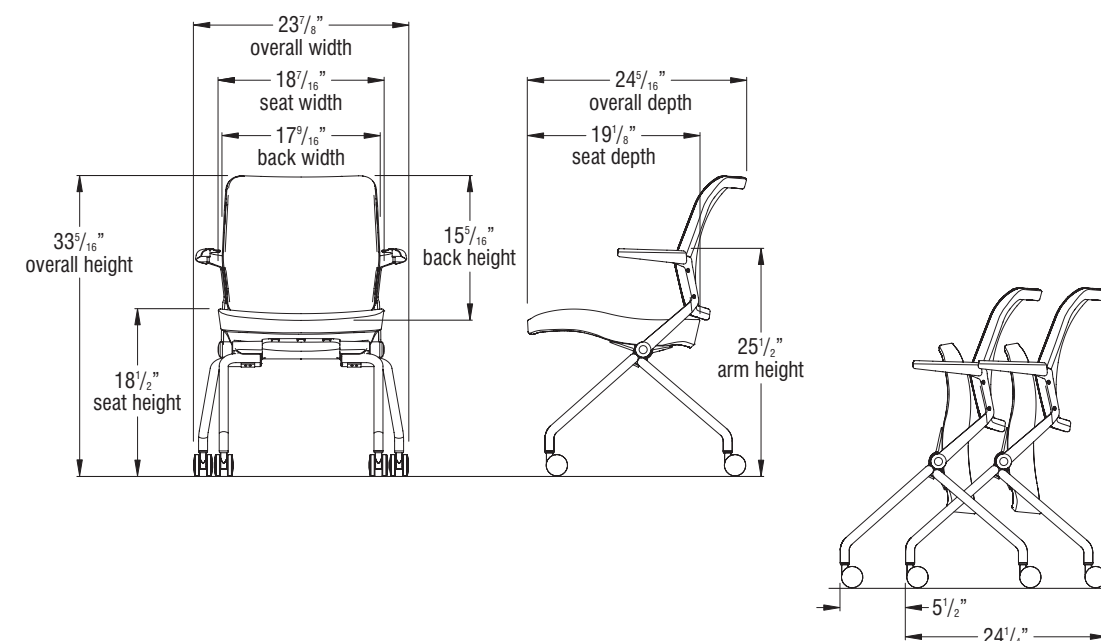

Nesting Footprint Calculation: Overall Length of a Row = 24.25" (1 chair) + 5.5" (additional chairs)

Examples: 2 Chairs: 24.25" (1 chair) + 5.5" (1 chair) = 29.75"

16 Chairs: 24.25" (1 chair) + 5.5" (15 chairs) = 106.75"

**Frame Color**

Black	BL
Blue Grey	GR
Bronze Metallic	ZM
Cayenne	CY
Champagne Metallic	CM
Chrome	CH
Cool Grey	CG
Cottonwood	CO
Earthen Clay	EY
Espresso Metallic	EX
Everglade Shade	EV
Flannel	FN
Glitz Metallic	GZ
Hazy Jade	HJ
Honey Bee	HY
Light Tone	LG
Mardi Gras	MG
Misty Brown	MY
Nemo	NE
Nordic	ND
Purple Haze	PH
Rainforest	RQ
Raw Jasper	RJ
Rubber Ducky	RK
Sand	SA
Starlight Silver Metallic	SX
Surf's Up	SP
Tarragon	TQ
Twilight Shadow	TI
Ultra Blue	UB
Warm Grey	WG
Zesty Lime	ZL

Back Mesh

Black	BLMH
Grey	GRMH

Tablet Arm Color - Piretti Tablet

Black	LBK
-------	-----



Finish Cards

View color swatches for items listed within this document.

[Paints](#)[Plastics/Poly](#)[Wood/Veneer](#)[Laminates](#)[Molded Edges](#)[Edge Styles](#)[Hard Plastics](#)[Glass](#)

Certain options referenced may not be available on GSA Schedule.



MODEL	Features	MODEL NUMBER							Approx. Packaged Weight	Delivered Pricing Fabric Grade 1 & C.O.M.	Delivered Pricing Fabric Grade 2	Delivered Pricing Fabric Grade 3	Delivered Pricing Vinyl Group 2V	Delivered Pricing Pallas Fabric Group P0	Delivered Pricing Pallas Fabric Group P1	Delivered Pricing Pallas Fabric Group P2	Delivered Pricing Pallas Fabric Group P3	Delivered Pricing Pallas Fabric Group P4
		Basic Model	Frame Color	Tablet Arm Color	Base	Upholstery Color	Fire Code	Mesh Color										
 Armless Chair • Back flex • Mesh back TANC		TANNA	<input type="checkbox"/>		<input type="checkbox"/>	<input type="checkbox"/> <input type="checkbox"/> <input type="checkbox"/> <input type="checkbox"/>	<input type="checkbox"/>	<input type="checkbox"/> <input type="checkbox"/> <input type="checkbox"/>	24.0#	\$ 920	\$ 939	\$ 957	\$ 957	\$ 968	\$ 1018	\$ 1038	\$ 1065	\$ 1098
 Arm Chair • Back flex • Mesh back TANC		TANWA	<input type="checkbox"/>		<input type="checkbox"/>	<input type="checkbox"/> <input type="checkbox"/> <input type="checkbox"/> <input type="checkbox"/>	<input type="checkbox"/>	<input type="checkbox"/> <input type="checkbox"/> <input type="checkbox"/>	25.0#	\$ 956	\$ 982	\$ 996	\$ 996	\$ 1004	\$ 1055	\$ 1078	\$ 1102	\$ 1137
 Flip-up Tablet Arm Chair • Back flex • Mesh back TANC	Flip Tablet, Left Hand	TANTALFT	<input type="checkbox"/>	<input type="checkbox"/> <input type="checkbox"/>	<input type="checkbox"/>	<input type="checkbox"/> <input type="checkbox"/> <input type="checkbox"/> <input type="checkbox"/>	<input type="checkbox"/>	<input type="checkbox"/> <input type="checkbox"/> <input type="checkbox"/>	29.0#	\$ 1182	\$ 1201	\$ 1221	\$ 1221	\$ 1230	\$ 1281	\$ 1305	\$ 1328	\$ 1361
	Flip Tablet, Right Hand	TANTARFT	<input type="checkbox"/>	<input type="checkbox"/> <input type="checkbox"/>	<input type="checkbox"/>	<input type="checkbox"/> <input type="checkbox"/> <input type="checkbox"/> <input type="checkbox"/>	<input type="checkbox"/>	<input type="checkbox"/> <input type="checkbox"/> <input type="checkbox"/>	29.0#	1182	1201	1221	1221	1230	1281	1305	1328	1361

A **B** **C** **D** **E** **F** **G**

HOW TO ORDER

- Indicate the following information on order form:
- Quantity of each item.
 - Model number, including options. See "How To Build a Model Number".
 - Any special service required.

Note: • The indicates that a choice is required.
 • The absence of the indicates that no choice is required.
 • Alpha-numeric characters in place of indicate that no other alternatives are available.

HOW TO BUILD A MODEL NUMBER

- A** Select basic model.
- B** Select frame color. Refer to the **Product Color Options** page in this price list.
- C** Select tablet arm color. Refer to the **Product Color Options** page in this price list.
- D** Select base option.

G	- Bell glides (black only)
C	- Carpet casters (black only)
S	- Hard floor casters (black only)
- E** Select upholstery grade/color. Refer to ki.com/fabrics
- F** Select fire code.

NFR	- Compliance to TB 117-2013
FR	- Compliance to TB 133

- G** Select back mesh color.

BLMH	- Black
GRMH	- Grey

 Refer to ki.com/fabrics

UPHOLSTERY INFORMATION

C.O.M. Upholstery
 C.O.M. requirement for 10 chairs or less is 3/4 yard per chair of 54" wide nondirectional fabric. For orders of 11 or more chairs and for complete information on ordering C.O.M., see "Ordering Customer Ordered Material (C.O.M) Upholstery." section.

OPTIONS

California TB133 Fire Safety Code
 For California Technical Bulletin 133 compliant models, add the following upcharge:
 Added Lead Time=1 week
 Added list price=\$64

SPECIAL SERVICES

Special Carton Marking

With specially marked information N/C

Shipping
 Ships **assembled, FOB Green Bay, WI 54302, freight prepaid.** Freight class 125.

Specifications and prices are subject to change without prior notice.



MODEL	Features	MODEL NUMBER						Approx. Packaged Weight	Delivered Pricing Fabric Grade 1 & C.O.M.	Delivered Pricing Fabric Grade 2	Delivered Pricing Fabric Grade 3	Delivered Pricing Vinyl Group 2V	Delivered Pricing Pallas Fabric Group P0	Delivered Pricing Pallas Fabric Group P1	Delivered Pricing Pallas Fabric Group P2	Delivered Pricing Pallas Fabric Group P3	Delivered Pricing Pallas Fabric Group P4
		Basic Model	Frame Color	Base	Upholstery Color	Fire Code	Mesh Color										
 Piretti Tablet Arm Chair • Back flex • Mesh back	Piretti Tablet, Left Hand	TANTALPT	<input type="checkbox"/>	<input type="checkbox"/>	<input type="checkbox"/>	<input type="checkbox"/>	<input type="checkbox"/>	34.0#	\$ 1325	\$ 1345	\$ 1364	\$ 1364	\$ 1375	\$ 1423	\$ 1448	\$ 1472	\$ 1507
	Piretti Tablet, Right Hand	TANTARPT	<input type="checkbox"/>	<input type="checkbox"/>	<input type="checkbox"/>	<input type="checkbox"/>	<input type="checkbox"/>	34.0#	1325	1345	1364	1364	1375	1423	1448	1472	1507

TANC

HOW TO ORDER

- Indicate the following information on order form:
- Quantity of each item.
 - Model number, including options. See "How To Build a Model Number".
 - Any special service required.

Note:

- The indicates that a choice is required.
- The absence of the indicates that no choice is required.
- Alpha-numeric characters in place of indicate that no other alternatives are available.

HOW TO BUILD A MODEL NUMBER

- A** Select basic model.
- B** Select frame color.
Refer to the **Product Color Options** page in this price list.
- C** Select base option.

G	- Bell glides (black only)
C	- Carpet casters (black only)
S	- Hard floor casters (black only)
- D** Select upholstery grade/color.
Refer to ki.com/fabrics
- E** Select fire code.

NFR	- Compliance to TB 117-2013
FR	- Compliance to TB 133
- F** Select back mesh color.

BLMH	- Black
GRMH	- Grey

 Refer to ki.com/fabrics

UPHOLSTERY INFORMATION

C.O.M. Upholstery
 C.O.M. requirement for 10 chairs or less is 3/4 yard per chair of 54" wide nondirectional fabric. For orders of 11 or more chairs and for complete information on ordering C.O.M., see "Ordering Customer Ordered Material (C.O.M) Upholstery." section.

SPECIAL SERVICES

Special Carton Marking

With specially marked information N/C

Shipping

Ships **assembled, FOB Green Bay, WI 54302, freight prepaid.** Freight class 125.

Specifications and prices are subject to change without prior notice.

Torsion Air® Stack Seating

General Information



Torsion Air® Stack Seating

General Information



Four-Leg Armless Chair (TALNA)



Four-Leg Arm Chair (TALWA)



Four-Leg Standard Tablet Arm Chair (TALTAR)

Features			
Back flex	•	•	•
Stackable	•	•	•
General Dimensions			
Seat width	17"	17"	17"
Seat depth	18-1/2"	18-1/2"	18-1/2"
Seat height	18"	18"	18"
Back width	17"	17"	17"
Back height	16"	16"	16"
Overall Dimensions			
Width	21"	23-1/2"	23"
Depth	23-3/4"	23-3/4"	29-3/4"
Height	34"	34"	34"
Top of arm to floor		25-1/2"	28"
Stacking on Dolly			
Quantity/height	5 Chairs/55" High	5 Chairs/55" High	
Floor space	22-1/2" x 25-1/2"	23-1/2" x 25-1/2"	
Stacking on Floor			
Quantity/height	4 Chairs/45" High	4 Chairs/45" High	4 Chairs/45" High
Floor space	21" x 32"	23-1/2" x 32"	23-1/2" x 32"

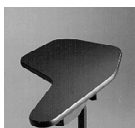

Standard Flip-Up Tablet Arm



Sled Base Armless Chair (TASNA)



Sled Base Arm Chair (TASWA)

Sled Base Standard Tablet Arm Chair (TASTAR)

Features			
Back flex	•	•	•
Stackable	•	•	
General Dimensions			
Seat width	17"	17"	17"
Seat depth	18-1/2"	18-1/2"	18-1/2"
Seat height	18"	18"	18"
Back width	17"	17"	17"
Back height	16"	16"	16"
Overall Dimensions			
Width	21"	23-1/2"	23"
Depth	23-3/4"	23-3/4"	29-3/4"
Height	34"	34"	34"
Top of arm to floor		25-1/2"	28"
Stacking on Dolly			
Quantity/height	5 Chairs/55" High	5 Chairs/55" High	
Floor space	22-1/2" x 25-1/2"	23-1/2" x 25-1/2"	
Stacking on Floor			
Quantity/height	4 Chairs/45" High	4 Chairs/45" High	
Floor space	21" x 32"	23-1/2" x 32"	

INFORMATION

C.O.M. Testing and Production Requirements

Not all materials are suitable for upholstering this product. A 1 yd. x 54" sample must be submitted and approved prior to acceptance of an order. If the fabric is directional in pattern or weave, the direction must be indicated on the submitted sample, and additional yardage may be requested.

Test samples must be sent to:

KI
Attn: C.O.M. Specialist
1687 Westminster Drive - Gate 3
Green Bay, WI 54302

Fabric Disclaimer

Fabric will be applied as swatched by the fabric manufacturer. Fabric that is required to be applied differently than is swatched will need a Modified Product Request written specifying the direction the fabric is to be applied.

KI Color Match Program

KI offers the additional option of color matching paint, polypropylene, or wood stain through Product Modification Requests. Contact Customer Service for details.

Whatever you imagine, whatever you require, KI's Color Match program lets you pick your color!

Color Match Process - Poly Seating Information can be found here.

Stacking Vinyl, Polyurethane, and Imitation Leather Upholstered Chairs

If stacking frequently and for long periods of time, it is recommended that upholstery other than vinyl, polyurethane or imitation leather be used to avoid impressions in the seat cushion. KI does not warrant the effects of stacking on stock or COM vinyl, polyurethane or imitation leather upholstery.

INFORMATION

Warranty

Refer to KI Terms & Conditions document or visit ki.com

**Seat and Backrest**

Seat is a two-piece construction with a molded polypropylene liner with a molded compound curved polypropylene shroud with a textured finish. Seat is always upholstered. Foam (1 1/2") is applied to the molded polypropylene liner. Fabric is then upholstered over the foam. Backrest frame is molded glass-reinforced nylon. Mesh fabric is 100% polyester. Seat and backrest are field-replaceable.

Back/Arm Supports

Two welded steel backrest supports attach the backrest to the torsion mechanism. If so equipped, optional armrest structure is integral to the backrest support. Armcaps are polypropylene and are field-replaceable.

Torsion Mechanism

The back flex is achieved by the torsion mechanism. It consists of two flat torsion springs captured at both ends by steel bushings that are welded to the backrest supports. The torsion mechanism creates gradually increasing resistance over the full 12° of back flex.

Full Sled Base Frame ("TAS")

The sled base frame consists of two segments of 3/4" 16-gauge seam welded tubular steel and two steel seat supports.

Four Leg Frame ("TAL")

The four leg frame consists of two U-shaped sections, one front and one rear, welded together with two support brackets to form the four leg chair. The sections are formed of 15/16" 15-gauge seam welded tubular steel.

Leg Finishes

Baked-on, electrostatically-applied powder-coating, or bright nickel-chrome plating.

Tablet Arms - Standard

5/8" 11-ply plywood tablet with high-pressure laminate surface and lacquered edge. Tablet arm support matches frame color. Seating clearance is 13 1/2". Standard tablet measures 19 1/2" long and 12 3/4" wide.

Transport Dolly

Tubular and plate steel welded together. 5" casters; two fixed, two swivel. Powder coated finish. Two distinct dollies are available; one for full Sled Base, and one for Four Leg.

**Frame Color**

Black	BL	Graphite Nebula	LGN
Blue Grey	GR	Grey	LGE
Bronze Metallic	ZM	High Rise	LHE
Cayenne	CY	Hollyberry	LHY
Champagne Metallic	CM	Island	LID
Chrome	CH	Italian Silver Ash	LIT
Cool Grey	CG	Kensington Maple	LKM
Cottonwood	CO	Lapis Blue	LLB
Earthen Clay	EY	Monticello Maple	LMT
Espresso Metallic	EX	North Sea	LNA
Everglade Shade	EV	Ocean	LON
Flannel	FN	Pinnacle Walnut	LPW
Glitz Metallic	GZ	River Cherry	LRV
Hazy Jade	HJ	Shadow Zephyr	LSR
Honey Bee	HY	Sterling Ash	LAZ
Light Tone	LG	Titanium Evolv	LTV
Mardi Gras	MG	White Nebula	LWL
Misty Brown	MY	White Sand	LWN
Nemo	NE	Windsor Mahogany	LWY
Nordic	ND		
Purple Haze	PH		
Rainforest	RQ		
Raw Jasper	RJ		
Rubber Ducky	RK		
Sand	SA		
Starlight Silver Metallic	SX		
Surf's Up	SP		
Tarragon	TQ		
Twilight Shadow	TI		
Ultra Blue	UB		
Warm Grey	WG		
Zesty Lime	ZL		

Back Mesh

Black	BLMH
Grey	GRMH

Tablet Arm Color - Piretti Tablet

Black	LBK
-------	-----

Tablet Arm Color - Laminate**Flip and G-Tablet**

Beigewood	LBZ
Belair	LBQ
Biltmore Cherry	LBT
Black	LBK
Brighton Walnut	LBW
Castle Oak	LCO
Cherry Storm	LCX
Classic Linen	LCI
Cocobala	LCC
Crisp Linen	LRI
Designer White	LDR
Dove Grey	LDG
Florence Walnut	LFC
Friston Ash	LFH
Frosty White	LFW



Finish Cards

View color swatches for items listed within this document.

[Paints](#)[Plastics/Poly](#)[Wood/Veneer](#)[Laminates](#)[Molded Edges](#)[Edge Styles](#)[Hard Plastics](#)[Glass](#)

Certain options referenced may not be available on GSA Schedule.



MODEL	Features	MODEL NUMBER							Approx. Packaged Weight	Delivered Pricing Fabric Grade 1 & C.O.M.	Delivered Pricing Fabric Grade 2	Delivered Pricing Fabric Grade 3	Delivered Pricing Vinyl Group 2V	Delivered Pricing Pallas Fabric Group P0	Delivered Pricing Pallas Fabric Group P1	Delivered Pricing Pallas Fabric Group P2	Delivered Pricing Pallas Fabric Group P3	Delivered Pricing Pallas Fabric Group P4
		Basic Model	Frame Color	Tablet Arm Color	Glide Option	Upholstery Color	Fire Code	Mesh Color										
 <p>Four-Leg Armless Chair • Back flex • Mesh back • Stacking</p>		TALNA	<input type="checkbox"/>		<input type="checkbox"/>	<input type="checkbox"/>	<input type="checkbox"/>	<input type="checkbox"/>	18.0#	\$ 681	\$ 699	\$ 719	\$ 719	\$ 731	\$ 781	\$ 801	\$ 829	\$ 862
TALC																		
 <p>Four-Leg Arm Chair • Back flex • Mesh back • Stacking</p>		TALWA			<input type="checkbox"/>	<input type="checkbox"/>	<input type="checkbox"/>	<input type="checkbox"/>	20.0#	\$ 718	\$ 735	\$ 760	\$ 760	\$ 767	\$ 814	\$ 839	\$ 865	\$ 897
TALC																		
 <p>Four-Leg Tablet Arm Chair • Back flex • Mesh back • Stacking</p>	Standard Tablet, Left Hand	TALTAL	<input type="checkbox"/>	<input type="checkbox"/>	<input type="checkbox"/>	<input type="checkbox"/>	<input type="checkbox"/>	<input type="checkbox"/>	28.0#	\$ 944	\$ 960	\$ 986	\$ 986	\$ 993	\$ 1041	\$ 1065	\$ 1089	\$ 1125
	Standard Tablet, Right Hand	TALTAR	<input type="checkbox"/>	<input type="checkbox"/>	<input type="checkbox"/>	<input type="checkbox"/>	<input type="checkbox"/>	<input type="checkbox"/>	28.0#	944	960	986	986	993	1041	1065	1089	1125
TALC																		

A **B** **C** **D** **E** **F** **G**

HOW TO ORDER

Indicate the following information on order form:

- Quantity of each item.
- Model number, including options. See "How To Build a Model Number".
- Any special service required.

Note:

- The indicates that a choice is required.
- The absence of the indicates that no choice is required.
- Alpha-numeric characters in place of indicate that no other alternatives are available.

HOW TO BUILD A MODEL NUMBER

A Select basic model.

B Select frame color.
Refer to the **Product Color Options** page in this price list.

C Select tablet arm color.
Refer to the **Product Color Options** page in this price list.

D Select glide option.
P - Plastic glides
S - Stainless steel glides

E Select upholstery grade/color.
Refer to ki.com/fabrics

F Select fire code.
NFR - Compliance to TB 117-2013
FR - Compliance to TB 133

G Select back mesh color.
BLMH - Black
GRMH - Grey
Refer to ki.com/fabrics

UPHOLSTERY INFORMATION

C.O.M. Upholstery
C.O.M. requirement for 10 chairs or less is 3/4 yard per chair of 54" wide nondirectional fabric. For orders of 11 or more chairs and for complete information on ordering C.O.M., see "Ordering Customer Ordered Material (C.O.M) Upholstery." section.

OPTIONS

California TB133 Fire Safety Code
For California Technical Bulletin 133 compliant models, add the following upcharge:
Added Lead Time=1 week
Added list price=\$64



SPECIAL SERVICES

Special Carton Marking
With specially marked information N/C

Shipping
Ships assembled, FOB Green Bay, WI 54302, freight prepaid. Freight class 125.

Specifications and prices are subject to change without prior notice.



MODEL	Features	MODEL NUMBER							Approx. Packaged Weight	Delivered Pricing Fabric Grade 1 & C.O.M.	Delivered Pricing Fabric Grade 2	Delivered Pricing Fabric Grade 3	Delivered Pricing Vinyl Group 2V	Delivered Pricing Pallas Fabric Group P0	Delivered Pricing Pallas Fabric Group P1	Delivered Pricing Pallas Fabric Group P2	Delivered Pricing Pallas Fabric Group P3	Delivered Pricing Pallas Fabric Group P4	
		Basic Model	Frame Color	Tablet Arm Color	Upholstery Color	Fire Code	Mesh Color	Glide Option											
 Sled Base Armless Chair • Back flex • Mesh back • Stacking		TASNA	<input type="checkbox"/>		<input type="checkbox"/> <input type="checkbox"/> <input type="checkbox"/> <input type="checkbox"/>	<input type="checkbox"/>	<input type="checkbox"/> <input type="checkbox"/> <input type="checkbox"/>	<input type="checkbox"/>	18.0#	\$ 681	\$ 699	\$ 719	\$ 719	\$ 731	\$ 781	\$ 801	\$ 829	\$ 862	
TASC																			
 Sled Base Arm Chair • Back flex • Mesh back • Stacking		TASWA	<input type="checkbox"/>		<input type="checkbox"/> <input type="checkbox"/> <input type="checkbox"/> <input type="checkbox"/>	<input type="checkbox"/>	<input type="checkbox"/> <input type="checkbox"/> <input type="checkbox"/>	<input type="checkbox"/>	20.0#	\$ 718	\$ 735	\$ 760	\$ 760	\$ 767	\$ 814	\$ 839	\$ 865	\$ 897	
TASC																			
 Sled Base Tablet Arm Chair • Back flex • Mesh back • Nonstacking	Standard Tablet, Left Hand	TASTAL	<input type="checkbox"/>	<input type="checkbox"/> <input type="checkbox"/>	<input type="checkbox"/> <input type="checkbox"/> <input type="checkbox"/> <input type="checkbox"/>	<input type="checkbox"/>	<input type="checkbox"/> <input type="checkbox"/> <input type="checkbox"/>	<input type="checkbox"/>	28.0#	\$ 944	\$ 960	\$ 986	\$ 986	\$ 993	\$ 1041	\$ 1065	\$ 1089	\$ 1125	
	Standard Tablet, Right Hand	TASTAR	<input type="checkbox"/>	<input type="checkbox"/> <input type="checkbox"/>	<input type="checkbox"/> <input type="checkbox"/> <input type="checkbox"/> <input type="checkbox"/>	<input type="checkbox"/>	<input type="checkbox"/> <input type="checkbox"/> <input type="checkbox"/>	<input type="checkbox"/>	28.0#	944	960	986	986	993	1041	1065	1089	1125	
TASC																			

A **B** **C** **D** **E** **F** **G**

HOW TO ORDER

- Indicate the following information on order form:
- Quantity of each item.
 - Model number, including options. See "How To Build a Model Number".
 - Any special service required.

Note: • The indicates that a choice is required.
 • The absence of the indicates that no choice is required.
 • Alpha-numeric characters in place of indicate that no other alternatives are available.

HOW TO BUILD A MODEL NUMBER

- A** Select basic model.
- B** Select frame color. Refer to the **Product Color Options** page in this price list.
- C** Select tablet arm color. Refer to the **Product Color Options** page in this price list.
- D** Select upholstery grade/color. Refer to ki.com/fabrics
- E** Select fire code.
 - NFR** - Compliance to TB 117-2013
 - FR** - Compliance to TB 133
- F** Select back mesh color.
 - BLMH** - Black
 - GRMH** - Grey
 Refer to ki.com/fabrics

- G** Select glide option.
 - N** - No glides
 - GNM** - Non-marring glides
 - GNS** - Non-skid glides
 - GBL** - Plastic glides
 - GSS** - Stainless steel glide

UPHOLSTERY INFORMATION

C.O.M. Upholstery
 C.O.M. requirement for 10 chairs or less is 3/4 yard per chair of 54" wide nondirectional fabric. For orders of 11 or more chairs and for complete information on ordering C.O.M., see "Ordering Customer Ordered Material (C.O.M) Upholstery." section.

OPTIONS

California TB133 Fire Safety Code
 For California Technical Bulletin 133 compliant models, add the following upcharge:
 Added Lead Time=1 week
 Added list price=\$64

SPECIAL SERVICES



Special Carton Marking

With specially marked information N/C

Shipping
 Ships **assembled, FOB Green Bay, WI 54302, freight prepaid.** Freight class 125.

Specifications and prices are subject to change without prior notice.

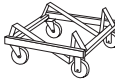

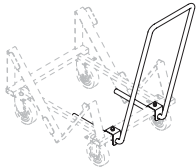
MODEL	MODEL NUMBER		Approx. Packaged Weight	Delivered Pricing
	Basic Model			
 <p>Transport Dolly for Sled Base Chairs</p> <ul style="list-style-type: none"> • For full sled base chairs • 5" casters: two fixed, two swivel • Black only 	TVD.BL		30.0#	\$ 564
HRDPT				
 <p>Transport Dolly for Four-Leg Chairs</p> <ul style="list-style-type: none"> • For four-Leg chairs only • 5" casters: two fixed, two swivel • Black only 	TLD.BL		31.0#	\$ 564
HRDPT				
 <p>Universal Dolly Handle</p> <ul style="list-style-type: none"> • Field installable • Provides convenient handle for relocating dolly when empty or loaded • Overall dolly height with handle is 37" 	UDH.BL		8.0#	\$ 199
HRDPT				

A

HOW TO ORDER

- Indicate the following information on order form:
1. Quantity of each item.
 2. Model number, including options. See "How To Build a Model Number".
 3. Any special service required.

- Note:
- The indicates that a choice is required.
 - The absence of the indicates that no choice is required.
 - Alpha-numeric characters in place of indicate that no other alternatives are available.

HOW TO BUILD A MODEL NUMBER

- A** Select basic model.



Armless Task Chair
(TAPDNA)



Task Armchair
(TAPDWA)



Armless Task Stool
(TASPNA)



Task Stool with Arms
(TASPWA)

Features				
Back Flex	•	•	•	•
Pneumatic seat height adjustment	•	•	•	•
General Dimensions				
Seat width	17"	17"	17"	17"
Seat depth	18-1/2"	18-1/2"	18-1/2"	18-1/2"
Seat height (stools with polished aluminum base - subtract 1-3/4")	18" - 23"	18" - 23"	23" - 33-1/4"	23" - 33-1/4"
Back width	17"	17"	17"	17"
Back height	16"	16"	16"	16"
Overall Dimensions				
Depth	26-1/2"	26-1/2"	26-1/2"	26-1/2"
Height	33-1/2" x 38-1/2"	33-1/2" x 38-1/2"	38-1/2" x 48-3/4"	38-1/2" x 48-3/4"
Width	26-1/2"	26-1/2"	27-1/2"	27-1/2"
Top of arm to floor		25" - 30"		30" - 40-1/4"

INFORMATION

C.O.M. Testing and Production Requirements

Not all materials are suitable for upholstering this product. A 1 yd. x 54" sample must be submitted and approved prior to acceptance of an order. If the fabric is directional in pattern or weave, the direction must be indicated on the submitted sample, and additional yardage may be requested.

Test samples must be sent to:

KI
Attn: C.O.M. Specialist
1687 Westminster Drive - Gate 3
Green Bay, WI 54302

Fabric Disclaimer

Fabric will be applied as swatched by the fabric manufacturer. Fabric that is required to be applied differently than is swatched will need a Modified Product Request written specifying the direction the fabric is to be applied.

KI Color Match Program

KI offers the additional option of color matching paint, polypropylene, or wood stain through Product Modification Requests. Contact Customer Service for details.

Whatever you imagine, whatever you require, KI's Color Match program lets you pick your color!

Color Match Process - Poly Seating Information can be found here.

INFORMATION

Warranty

Refer to KI Terms & Conditions document or visit ki.com

TECHNICAL SPECIFICATIONS

Seat and Backrest

Seat is a two-piece construction with a molded polypropylene liner, a molded compound curved polypropylene shroud and a textured finish. Seat is always upholstered. Foam (1 1/2") is applied to the molded polypropylene liner. Fabric is then upholstered over the foam. Backrest frame is molded glass-reinforced nylon. Mesh fabric is 100% polyester. Seat and backrest are field-replaceable.

Back/Arm Supports

Two welded steel backrest supports attach the backrest to the torsion mechanism. If so equipped, optional armrest structure is integral to the backrest support. Armcaps are polypropylene and are field-replaceable.

Torsion Mechanism

The back flex is achieved by the torsion mechanism. It consists of two flat torsion springs captured at both ends by steel bushings that are welded to the backrest supports. The torsion mechanism creates gradually increasing resistance over the full 12° of back flex.

Base

The 26" diameter 5-blade base is made of injection-molded glass-reinforced nylon. A single paddle under the seat operates the height-adjusting pneumatic cylinder. Standard chair base and cylinder available in black only. Standard stool base available in black only. An optional polished die-cast aluminum base is available on both chairs and stools.

Pedestal Casters

Double wheels of high-impact thermoplastic.

Foot Ring

Task stools are equipped with a twist-to-lock, adjustable-height, 20" diameter chrome-plated steel foot ring with black, die-cast aluminum hub and spokes.

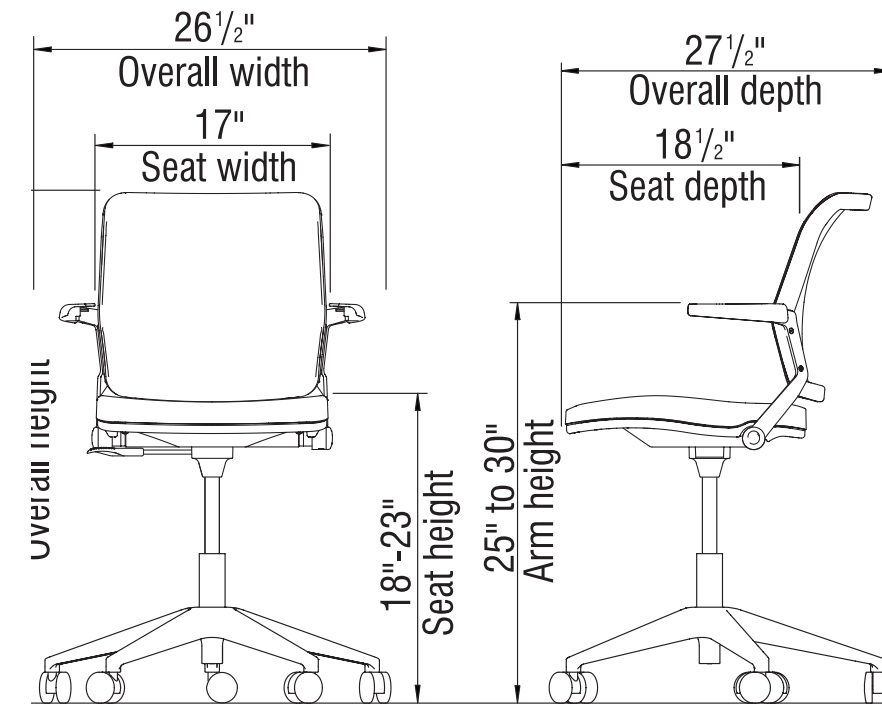

Task Chair

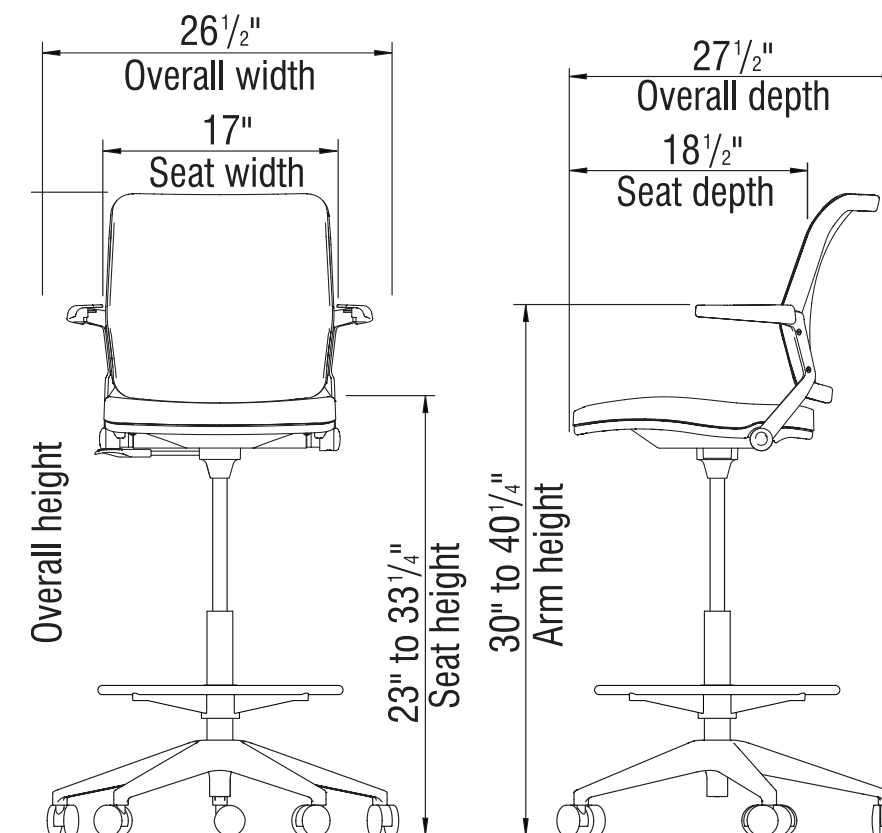

Task Stool



Back Mesh Color

Black	BLMH
Grey	GRMH

Base Color

Black	BL
Polished Aluminum	PA

Polished aluminum requires an upcharge.

Base color selection includes; seat plate/mechanism and back/arm supports which are always black.

Finish Cards

View color swatches for items listed within this document.

Paints

Wood/Veneer

Molded Edges

Hard Plastics

Plastics/Poly



Laminates

Edge Styles

Glass

Certain options referenced may not be available on GSA Schedule.



MODEL	MODEL NUMBER						Approx. Packaged Weight	Delivered Pricing Fabric Grade 1 & C.O.M.	Delivered Pricing Fabric Grade 2	Delivered Pricing Fabric Grade 3	Delivered Pricing Vinyl Group 2V	Delivered Pricing Pallas Fabric Group P0	Delivered Pricing Pallas Fabric Group P1	Delivered Pricing Pallas Fabric Group P2	Delivered Pricing Pallas Fabric Group P3	Delivered Pricing Pallas Fabric Group P4
	Basic Model	Base Color	Base	Fire Code	Upholstery Color	Mesh Color										
 <p>Task Armless Chair</p> <ul style="list-style-type: none"> • Back flex • Mesh back • Base available in black or polished aluminum 	TAPDNA	<input type="checkbox"/>	<input type="checkbox"/>	<input type="checkbox"/>	<input type="checkbox"/>	<input type="checkbox"/>	24.0#	\$ 874	\$ 891	\$ 913	\$ 913	\$ 920	\$ 970	\$ 995	\$ 1020	\$ 1054
	TAPD															
 <p>Task Armchair</p> <ul style="list-style-type: none"> • Back flex • Mesh back • Base available in black or polished aluminum 	TAPDWA	<input type="checkbox"/>	<input type="checkbox"/>	<input type="checkbox"/>	<input type="checkbox"/>	<input type="checkbox"/>	26.0#	\$ 912	\$ 930	\$ 950	\$ 950	\$ 959	\$ 1009	\$ 1031	\$ 1059	\$ 1090
	TAPD															

A **B** **C** **D** **E** **F**

HOW TO ORDER

- Indicate the following information on order form:
- Quantity of each item.
 - Model number, including options. See "How To Build a Model Number".
 - Any special service required.

Note:

- The indicates that a choice is required.
- The absence of the indicates that no choice is required.
- Alpha-numeric characters in place of indicate that no other alternatives are available.

HOW TO BUILD A MODEL NUMBER

- A** Select basic model.
- B** Select base color. Refer to the **Product Color Options** page in this price list. Base color selection includes seat plate/mechanism and back/arm supports and are always black. *Add \$112 for polished aluminum base.
- C** Select base option.
 - C** - Carpet casters
 - S** - Hard floor casters
 Hard floor casters and glides are available only in black.
- D** Select fire code.
 - NFR** - Compliance to TB 117-2013
 - FR** - Compliance to TB 133
 See FR upcharge under Options.
- E** Select upholstery grade/color. Refer to ki.com/fabrics
- F** Select back mesh color.
 - BLMH** - Black
 - GRMH** - Grey
 Refer to ki.com/fabrics

UPHOLSTERY INFORMATION

C.O.M. Upholstery
C.O.M. requirement for 10 chairs or less is 3/4 yard per chair of 54" wide nondirectional fabric. For orders of 11 or more chairs, and for complete information on ordering C.O.M., see "Ordering Customer Ordered Material (C.O.M)" section.

OPTIONS

California TB133 Fire Safety Code
The above seating products can be manufactured using the appropriate flame-retardant materials for compliance to California Technical Bulletin 133.

Added Lead Time=1 week
Added list price=\$64

SPECIAL SERVICES



Special Carton Marking

With specially marked information N/C

Shipping
Ships **knocked down, FOB Green Bay, WI 54302, freight prepaid.** Freight class 100.

Specifications and prices are subject to change without prior notice.



MODEL	MODEL NUMBER						Approx. Packaged Weight	Delivered Pricing Fabric Grade 1 & C.O.M.	Delivered Pricing Fabric Grade 2	Delivered Pricing Fabric Grade 3	Delivered Pricing Vinyl Group 2V	Delivered Pricing Pallas Fabric Group P0	Delivered Pricing Pallas Fabric Group P1	Delivered Pricing Pallas Fabric Group P2	Delivered Pricing Pallas Fabric Group P3	Delivered Pricing Pallas Fabric Group P4
	Basic Model	Base Color	Base	Fire Code	Upholstery Color	Mesh Color										
 <p>Task Armless Stool</p> <ul style="list-style-type: none"> • Back flex • Mesh back • Base available in black or polished aluminum 	TASPNA	<input type="checkbox"/>	<input type="checkbox"/>	<input type="checkbox"/>	<input type="checkbox"/>	<input type="checkbox"/>	29.0#	\$ 999	\$ 1020	\$ 1038	\$ 1038	\$ 1051	\$ 1098	\$ 1122	\$ 1146	\$ 1180
	TASP	<input type="checkbox"/>	<input type="checkbox"/>	<input type="checkbox"/>	<input type="checkbox"/>	<input type="checkbox"/>										
 <p>Task Stool with Arms</p> <ul style="list-style-type: none"> • Back flex • Mesh back • Base available in black or polished aluminum 	TASPWA	<input type="checkbox"/>	<input type="checkbox"/>	<input type="checkbox"/>	<input type="checkbox"/>	<input type="checkbox"/>	31.0#	\$ 1037	\$ 1059	\$ 1078	\$ 1078	\$ 1089	\$ 1137	\$ 1159	\$ 1183	\$ 1219
	TASP	<input type="checkbox"/>	<input type="checkbox"/>	<input type="checkbox"/>	<input type="checkbox"/>	<input type="checkbox"/>										

A **B** **C** **D** **E** **F**

HOW TO ORDER

- Indicate the following information on order form:
1. Quantity of each item.
 2. Model number, including options. See "How To Build a Model Number".
 3. Any special service required.

Note:

- The indicates that a choice is required.
- The absence of the indicates that no choice is required.
- Alpha-numeric characters in place of indicate that no other alternatives are available.

HOW TO BUILD A MODEL NUMBER

- A** Select basic model.
- B** Select base color. Refer to the **Product Color Options** page in this price list. Base color selection includes seat plate/mechanism and back/arm supports and are always black. *For polished aluminum selection add \$112
- C** Select base option.
 - C** - Carpet casters
 - S** - Hard floor casters
 Hard floor casters and glides are available only in black.
- D** Select fire code.
 - FR** - Compliance to TB 133
 - NFR** - Compliance to TB 117-2013
 See FR upcharge under Options.
- E** Select upholstery grade/color. Refer to ki.com/fabrics

- F** Select back mesh color.
 - BLMH** - Black
 - GRMH** - Grey
 Refer to ki.com/fabrics

UPHOLSTERY INFORMATION

C.O.M. Upholstery
C.O.M. requirement for 10 chairs or less is 3/4 yard per chair of 54" wide nondirectional fabric. For orders of 11 or more chairs, and for complete information on ordering C.O.M., see "Ordering Customer Ordered Material (C.O.M)" section.

OPTIONS

California TB133 Fire Safety Code
The above seating products can be manufactured using the appropriate flame-retardant materials for compliance to California Technical Bulletin 133.
Added Lead Time=1 week
Added list price=\$64

SPECIAL SERVICES

Special Carton Marking
With specially marked information N/C

Shipping
Ships **knocked down, FOB Green Bay, WI 54302, freight prepaid.** Freight class 100.

Specifications and prices are subject to change without prior notice.



1330 BELLEVUE STREET
GREEN BAY, WI 54302
800.424.2432 / KI.COM

KI is a trusted expert for furniture and wall systems around the globe.
USA | CANADA | MEXICO | UK | EUROPE | ASIA | MIDDLE EAST
© 2023 Krueger International, Inc. All Rights Reserved.