

# PRODUCT SPECIFICATIONS ■

## Stout Tables

January 2024

### TECHNICAL SPECIFICATIONS

#### Table Frames

All table frames are shipped K.D. (knocked-down) and require assembly in the field.

##### Fixed-Height Frames

Table support framework consists of a pair of leg weldments made from 14-gauge cold-rolled steel square tubing. Each leg weldment consists of two 2<sup>1</sup>/<sub>4</sub>" square post legs, a 1<sup>3</sup>/<sub>4</sub>" square horizontal crossbeam, and post brackets formed from 11-gauge steel. Apron weldments of 14-gauge steel and corner brackets of 11-gauge steel span underneath the worksurface and connect the legs using 1<sup>1</sup>/<sub>4</sub>"-20 screws. Larger tables will include a center stringer which is also made from 14-gauge square tubing. Tops are secured to frames using # 12 x 3<sup>3</sup>/<sub>4</sub>" screws. Fixed-height tables are available in three heights: 29", 36", and 40" high with glides or casters.

\*Table height is determined using standard laminate worksurface.

##### Adjustable-Height Frames

Adjustable-height tables are similar in construction to fixed-height but include a set of inner legs and adjustment allowing for a height range\* of 27"-40" in 1" increments. Each leg's height is maintained with two 1<sup>1</sup>/<sub>4</sub>"-20 screws.

\*Table height range is determined using standard laminate worksurface.

#### Worksurface

##### Laminate Worksurface

Laminate worksurfaces are nominal 1<sup>1</sup>/<sub>4</sub>" thickness, with particleboard core, .030" thick high-pressure laminate top surface and .028" phenolic backer (bottom surface). Worksurfaces include 2 mm poly, edge banding (74P) for tamper and moisture resistance. All tops are pre-drilled for installation atop the table frame, as well as for attaching optional power modules and bag hooks at the job site.

##### Phenolic Resin Worksurface

Solid phenolic worksurface is a 1" thick, self-supporting flat panel composed of thermosetting resins, homogeneously reinforced with cellulose fibers and manufactured under high heat and pressure. The worksurface has a pigmented resin, decorative surface that is electron-beam cured. All tops are pre-drilled for installation atop the table frame, as well as optional power modules and bag hooks at the job site.

##### Butcher Block Wood Worksurface

Hard Rock Maple wood butcher block worksurface is 1<sup>3</sup>/<sub>4</sub>" thick and flat edge grain construction. Full-length strips are randomly placed and finished with clear, semi-gloss Varnique finish. All tops are pre-drilled for installation atop the table frame, as well as optional power modules and bag hooks at the job site.

##### Stainless Steel Worksurface

Stainless steel worksurfaces are a nominal 1<sup>1</sup>/<sub>2</sub>" thickness. Worksurfaces are constructed of heavy-duty, 16-gauge high-nickel content, type-300 steel with #4 polish surface. Stainless steel top edges and vertical corners have a 1<sup>1</sup>/<sub>4</sub>" radius and overlay a 1<sup>3</sup>/<sub>8</sub>" thick particleboard core containing a melamine underside backing with caulk seal between the particleboard and steel edge. Stainless steel tops are NSF certified for compliance with NSF/ANSI 2 food equipment standards. All worksurface undersides are pre-drilled for installation atop the Stout table frame, as well as pre-drilled for installation of undersurface power modules and bag hooks at the job site.

#### Casters or Glides

Glides are an available option for all tables. Casters are an available option for all tables except tables 24" deep.



Furnishing Knowledge®

### Casters or Glides (cont.)

#### Casters

Caster wheel diameter is 4" (100 mm), and the installed caster overall height is approximately 5<sup>3</sup>/<sub>8</sub>". Wheel is constructed of grey, non-marking thermoplastic with wheel surface having a 1<sup>1</sup>/<sub>4</sub>" wide tread. Caster wheels are locking on each table leg and install using a 1<sup>1</sup>/<sub>2</sub>-13 threaded stem into the bottom of the table leg. Caster units each contain a double ball bearing swivel head and housing made of pressed steel, bright zinc plated. Casters are installed tight into the bottom of the leg and are not height adjustable.

#### Glides

Glides are black nylon, overmolded on a steel insert for strength and have a smooth surface for mobility. Glide overall diameter is 2<sup>1</sup>/<sub>2</sub>" and installs into the bottom of the table leg using a 1<sup>1</sup>/<sub>2</sub>-13 threaded stem, providing for approximately 1" of adjustment range to accommodate uneven floors.

### Pegboard End Panels (optional)

Pegboard end panels are formed from 16-gauge cold-rolled steel and must be specified when ordering leg weldments, as they are welded in place to the leg set and are powder-coat painted together at the factory. Holes with an industry-standard diameter size of 9<sup>9</sup>/<sub>32</sub>" are spaced 1" on-center both horizontally and vertically to accommodate both KI and off-the-shelf pegboard components. Pegboard end panels are 6" tall and are positioned 3" below the top horizontal cross beam of the side leg weldments. Pegboards can be specified to be on one or both leg weldments of a table.

### Footrests (optional)

Footrest weldments are constructed of 14-gauge, 1<sup>3</sup>/<sub>4</sub>" cold rolled steel square tubing and are powder-coat painted. Mounting brackets under the footrest attach it between table legs using thread-forming screws, allowing for easy installation or removal. Footrest options are single, dual, or dual with shelf. The shelf option is only available with the dual footrest option. The shelf is made from 14-gauge steel and is powder-coat painted. The shelf is suspended in place between the dual footrest tubes using lower mounting brackets. The footrest height is 10" from the top of the footrest to the floor.

### Dean® Undersurface Power Modules (optional)

Stout tables can be specified with one or two Dean Undersurface power modules. The Dean Undersurface power module consists of two simplex receptacles (rated at 15 amps/125 volts), one USB-A port and one USB-C port, 2 amps per port. The modules are 5<sup>1</sup>/<sub>2</sub>" wide by 1<sup>7</sup>/<sub>8</sub>" tall by 2<sup>1</sup>/<sub>2</sub>" deep and have a smooth molded plastic faceplate with an anodized aluminum housing. Color options are Black, Cottonwood, Cool Grey, and Warm Gray. Modules come standard with either 9' or 15' cord with a 3-prong plug. A worksurface bracket will ship with every module to allow installation of the modules along any edge of the table. Dean undersurface power module is rated at 15 amps/120 volts and is UL listed.

Horizontal and vertical wire management components are included with each module. Horizontal wire management consists of hook and ladder style, cord holders that secure to the underside of the table worksurfaces. Vertical wire management consists of adhesive-back extruded aluminum channels that are powder-coat painted to match leg finish and are adhered to leg columns. Vertical wire management channels are 16" tall for adjustable-height tables and 29" fixed-height tables, and are 23" tall for 36" and 40" fixed-height tables.

### Bag Hooks (optional)

Two bag hook options are available, either for mounting under the worksurface, or for mounting to the pegboard end panel. Each bag hook is made from 14-gauge steel, is powder-coat painted and is field installed. The undersurface bag hook fastens underneath the top using two #12 x 3<sup>3</sup>/<sub>4</sub>" Phillips pan head screws to pre-drilled holes under the worksurface. The pegboard bag hook installs to the pegboard end panel using two #10 x 3<sup>3</sup>/<sub>8</sub>" screws and nuts. The quantity of undersurface bag hooks provided when ordering a table is determined by table size (two per 24" and 30" deep tables, four per 36", 42" and 48" deep tables). Pegboard bag hooks are ordered separately as accessories.

### Finish

Table frames are offered in numerous powder-coat colors. Powder-coat application is a hybrid epoxy, baked on to provide a scratch and stain resistant finish. If pegboards, single footrests, or dual footrests are specified, they will be the same color as the table.

### Compliance

Stout tables meet or exceed ANSI/BIFMA X5.5-2021.



# DIMENSIONS

## Stout 29" Fixed-Height Tables with Glides

Model Number	A Table Height	B Table Depth	C Table Width	D Space Between Legs	E Space Between Legs	F Space Between Aprons	G Space Between Apron & Stringer	H Apron-to-Floor Clearance
SUEAA2448	29"	23.93"	47.93"	15.43"	39.43"	15.93"	N/A	26.10"
SUEAA2460	29"	23.93"	59.93"	15.43"	51.43"	15.93"	N/A	26.10"
SUEAA2472	29"	23.93"	71.93"	15.43"	63.43"	15.93"	N/A	26.10"
SUEAA3048	29"	29.93"	47.93"	21.43"	39.43"	21.93"	N/A	26.10"
SUEAA3060	29"	29.93"	59.93"	21.43"	51.43"	21.93"	N/A	26.10"
SUEAA3072	29"	29.93"	71.93"	21.43"	63.43"	21.93"	N/A	26.10"
SUEAA3084	29"	29.93"	83.93"	21.43"	75.43"	21.93"	N/A	26.10"
SUEAA3648	29"	35.93"	47.93"	27.43"	39.43"	N/A	13.09"	26.10"
SUEAA3660	29"	35.93"	59.93"	27.43"	51.43"	N/A	13.09"	26.10"
SUEAA3672	29"	35.93"	71.93"	27.43"	63.43"	N/A	13.09"	26.10"
SUEAA3684	29"	35.93"	83.93"	27.43"	75.43"	N/A	13.09"	26.10"
SUEAA4248	29"	41.93"	47.93"	33.43"	39.43"	N/A	16.09"	26.10"
SUEAA4260	29"	41.93"	59.93"	33.43"	51.43"	N/A	16.09"	26.10"
SUEAA4272	29"	41.93"	71.93"	33.43"	63.43"	N/A	16.09"	26.10"
SUEAA4284	29"	41.93"	83.93"	33.43"	75.43"	N/A	16.09"	26.10"
SUEAA4848	29"	47.93"	47.93"	39.43"	39.43"	N/A	19.09"	26.10"
SUEAA4860	29"	47.93"	59.93"	39.43"	51.43"	N/A	19.09"	26.10"
SUEAA4872	29"	47.93"	71.93"	39.43"	63.43"	N/A	19.09"	26.10"
SUEAA4884	29"	47.93"	83.93"	39.43"	75.43"	N/A	19.09"	26.10"

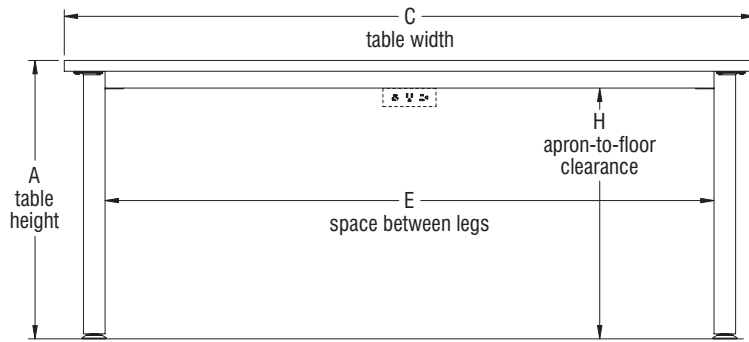

(front view)

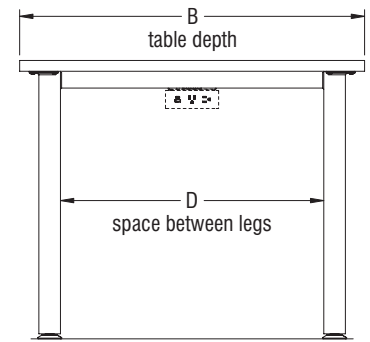

(side view)

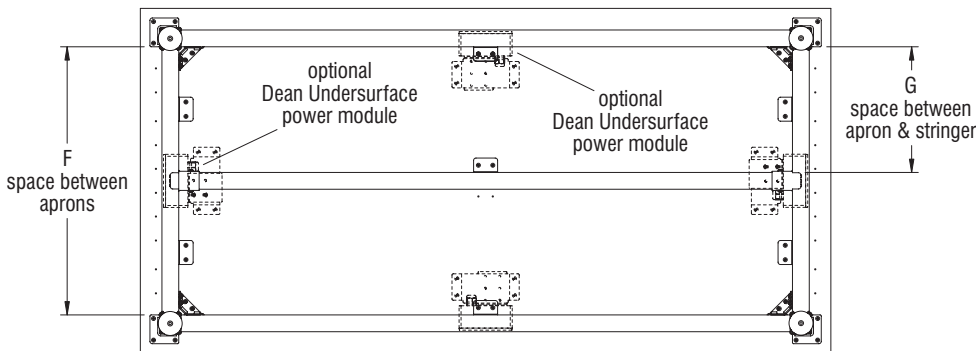

(bottom view)

**Note:** Table height dimensions in the chart above represent tables using a 1/4" thick laminate worksurface. Tables using a 1" thick phenolic resin worksurface must subtract 1/4" from the "table height" column in the chart. Tables using a 1 3/4" thick butcher block wood worksurface must add 1/2" to the "table height" column in the chart. Tables using a 1 1/2" thick stainless steel worksurface must add 1/4" to the "table height" column in the chart.

# DIMENSIONS

## Stout 36" Fixed-Height Tables with Glides

Model Number	A Table Height	B Table Depth	C Table Width	D Space Between Legs	E Space Between Legs	F Space Between Aprons	G Space Between Apron & Stringer	H Apron-to-Floor Clearance
SUEBA2448	36"	23.93"	47.93"	15.43"	39.43"	15.93"	N/A	33.10"
SUEBA2460	36"	23.93"	59.93"	15.43"	51.43"	15.93"	N/A	33.10"
SUEBA2472	36"	23.93"	71.93"	15.43"	63.43"	15.93"	N/A	33.10"
SUEBA3048	36"	29.93"	47.93"	21.43"	39.43"	21.93"	N/A	33.10"
SUEBA3060	36"	29.93"	59.93"	21.43"	51.43"	21.93"	N/A	33.10"
SUEBA3072	36"	29.93"	71.93"	21.43"	63.43"	21.93"	N/A	33.10"
SUEBA3084	36"	29.93"	83.93"	21.43"	75.43"	21.93"	N/A	33.10"
SUEBA3648	36"	35.93"	47.93"	27.43"	39.43"	N/A	13.09"	33.10"
SUEBA3660	36"	35.93"	59.93"	27.43"	51.43"	N/A	13.09"	33.10"
SUEBA3672	36"	35.93"	71.93"	27.43"	63.43"	N/A	13.09"	33.10"
SUEBA3684	36"	35.93"	83.93"	27.43"	75.43"	N/A	13.09"	33.10"
SUEBA4248	36"	41.93"	47.93"	33.43"	39.43"	N/A	16.09"	33.10"
SUEBA4260	36"	41.93"	59.93"	33.43"	51.43"	N/A	16.09"	33.10"
SUEBA4272	36"	41.93"	71.93"	33.43"	63.43"	N/A	16.09"	33.10"
SUEBA4284	36"	41.93"	83.93"	33.43"	75.43"	N/A	16.09"	33.10"
SUEBA4848	36"	47.93"	47.93"	39.43"	39.43"	N/A	19.09"	33.10"
SUEBA4860	36"	47.93"	59.93"	39.43"	51.43"	N/A	19.09"	33.10"
SUEBA4872	36"	47.93"	71.93"	39.43"	63.43"	N/A	19.09"	33.10"
SUEBA4884	36"	47.93"	83.93"	39.43"	75.43"	N/A	19.09"	33.10"

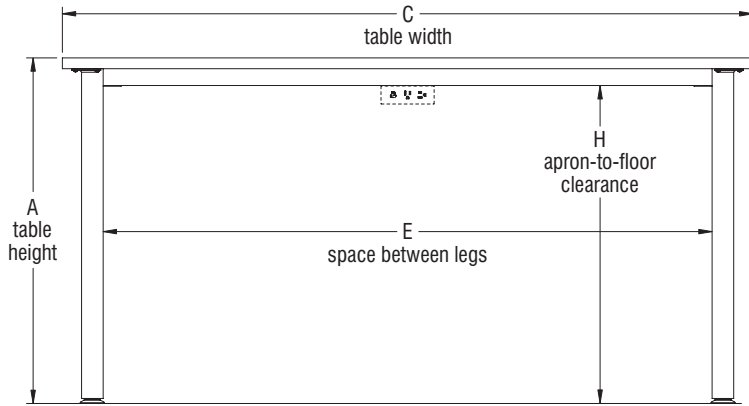

(front view)

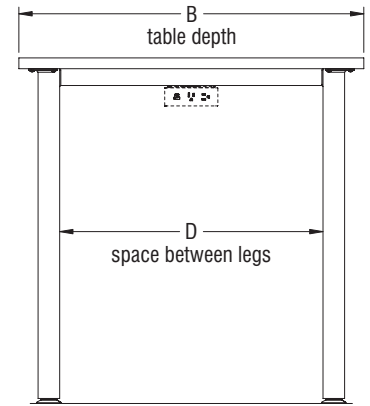

(side view)

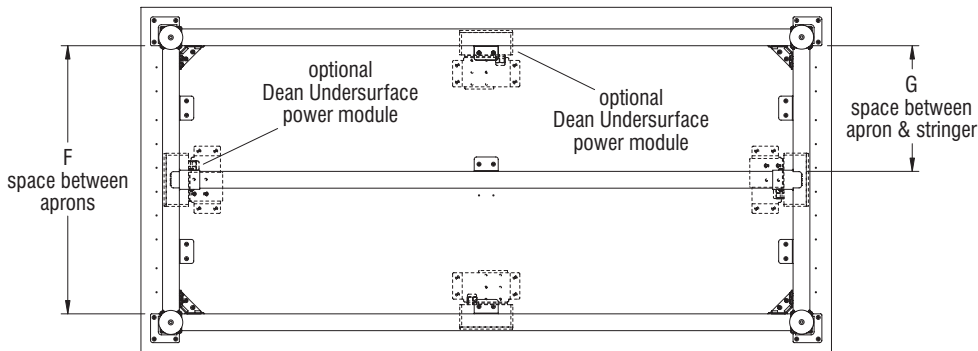

(bottom view)

**Note:** Table height dimensions in the chart above represent tables using a 1 1/4" thick laminate worksurface. Tables using a 1" thick phenolic resin worksurface must subtract 1/4" from the "table height" column in the chart. Tables using a 1 3/4" thick butcher block wood worksurface must add 1/2" to the "table height" column in the chart. Tables using a 1 1/2" thick stainless steel worksurface must add 1/4" to the "table height" column in the chart.

# DIMENSIONS

## Stout 40" Fixed-Height Tables with Glides

Model Number	A Table Height	B Table Depth	C Table Width	D Space Between Legs	E Space Between Legs	F Space Between Aprons	G Space Between Apron & Stringer	H Apron-to-Floor Clearance
SUEKA2448	40"	23.93"	47.93"	15.43"	39.43"	15.93"	N/A	37.10"
SUEKA2460	40"	23.93"	59.93"	15.43"	51.43"	15.93"	N/A	37.10"
SUEKA2472	40"	23.93"	71.93"	15.43"	63.43"	15.93"	N/A	37.10"
SUEKA3048	40"	29.93"	47.93"	21.43"	39.43"	21.93"	N/A	37.10"
SUEKA3060	40"	29.93"	59.93"	21.43"	51.43"	21.93"	N/A	37.10"
SUEKA3072	40"	29.93"	71.93"	21.43"	63.43"	21.93"	N/A	37.10"
SUEKA3084	40"	29.93"	83.93"	21.43"	75.43"	21.93"	N/A	37.10"
SUEKA3648	40"	35.93"	47.93"	27.43"	39.43"	N/A	13.09"	37.10"
SUEKA3660	40"	35.93"	59.93"	27.43"	51.43"	N/A	13.09"	37.10"
SUEKA3672	40"	35.93"	71.93"	27.43"	63.43"	N/A	13.09"	37.10"
SUEKA3684	40"	35.93"	83.93"	27.43"	75.43"	N/A	13.09"	37.10"
SUEKA4248	40"	41.93"	47.93"	33.43"	39.43"	N/A	16.09"	37.10"
SUEKA4260	40"	41.93"	59.93"	33.43"	51.43"	N/A	16.09"	37.10"
SUEKA4272	40"	41.93"	71.93"	33.43"	63.43"	N/A	16.09"	37.10"
SUEKA4284	40"	41.93"	83.93"	33.43"	75.43"	N/A	16.09"	37.10"
SUEKA4848	40"	47.93"	47.93"	39.43"	39.43"	N/A	19.09"	37.10"
SUEKA4860	40"	47.93"	59.93"	39.43"	51.43"	N/A	19.09"	37.10"
SUEKA4872	40"	47.93"	71.93"	39.43"	63.43"	N/A	19.09"	37.10"
SUEKA4884	40"	47.93"	83.93"	39.43"	75.43"	N/A	19.09"	37.10"

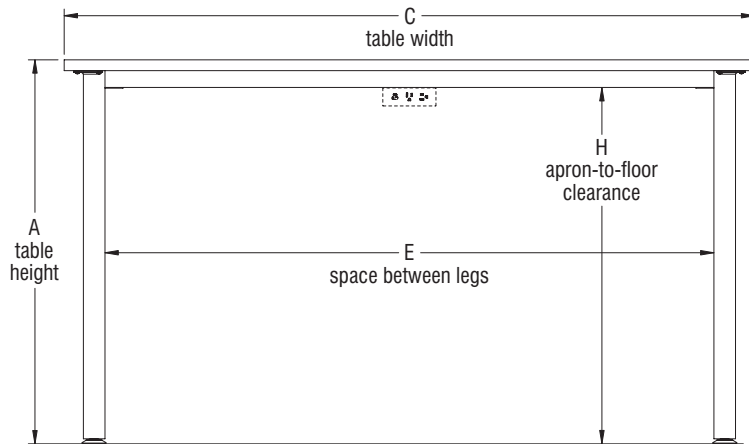

(front view)

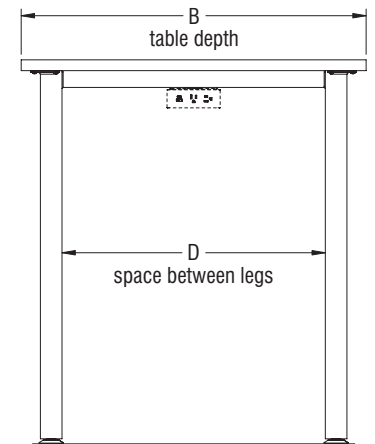

(side view)

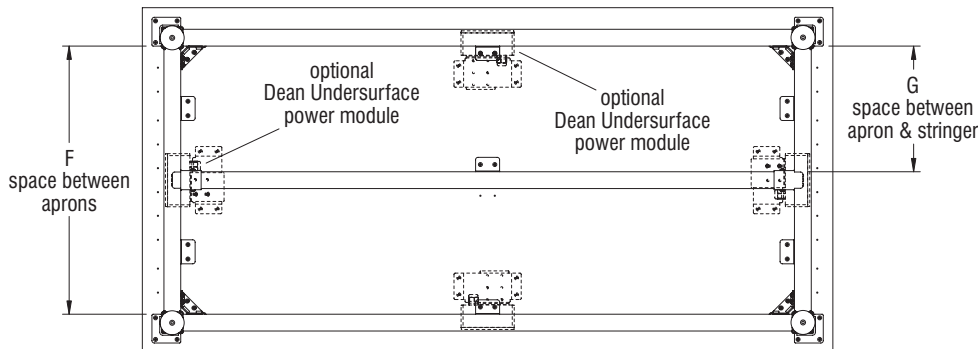

(bottom view)

**Note:** Table height dimensions in the chart above represent tables using a 1 1/4" thick laminate worksurface. Tables using a 1" thick phenolic resin worksurface must subtract 1/4" from the "table height" column in the chart. Tables using a 1 3/4" thick butcher block wood worksurface must add 1/2" to the "table height" column in the chart. Tables using a 1 1/2" thick stainless steel worksurface must add 1/4" to the "table height" column in the chart.

# DIMENSIONS

## Stout 29" Fixed-Height Tables with Casters

Model Number	A Table Height	B Table Depth	C Table Width	D Space Between Legs	E Space Between Legs	F Space Between Aprons	G Space Between Apron & Stringer	H Apron-to-Floor Clearance
SUEAA3048	29"	29.93"	47.93"	21.43"	39.43"	21.93"	N/A	26.10"
SUEAA3060	29"	29.93"	59.93"	21.43"	51.43"	21.93"	N/A	26.10"
SUEAA3072	29"	29.93"	71.93"	21.43"	63.43"	21.93"	N/A	26.10"
SUEAA3084	29"	29.93"	83.93"	21.43"	75.43"	21.93"	N/A	26.10"
SUEAA3648	29"	35.93"	47.93"	27.43"	39.43"	N/A	13.09"	26.10"
SUEAA3660	29"	35.93"	59.93"	27.43"	51.43"	N/A	13.09"	26.10"
SUEAA3672	29"	35.93"	71.93"	27.43"	63.43"	N/A	13.09"	26.10"
SUEAA3684	29"	35.93"	83.93"	27.43"	75.43"	N/A	13.09"	26.10"
SUEAA4248	29"	41.93"	47.93"	33.43"	39.43"	N/A	16.09"	26.10"
SUEAA4260	29"	41.93"	59.93"	33.43"	51.43"	N/A	16.09"	26.10"
SUEAA4272	29"	41.93"	71.93"	33.43"	63.43"	N/A	16.09"	26.10"
SUEAA4284	29"	41.93"	83.93"	33.43"	75.43"	N/A	16.09"	26.10"
SUEAA4848	29"	47.93"	47.93"	39.43"	39.43"	N/A	19.09"	26.10"
SUEAA4860	29"	47.93"	59.93"	39.43"	51.43"	N/A	19.09"	26.10"
SUEAA4872	29"	47.93"	71.93"	39.43"	63.43"	N/A	19.09"	26.10"
SUEAA4884	29"	47.93"	83.93"	39.43"	75.43"	N/A	19.09"	26.10"

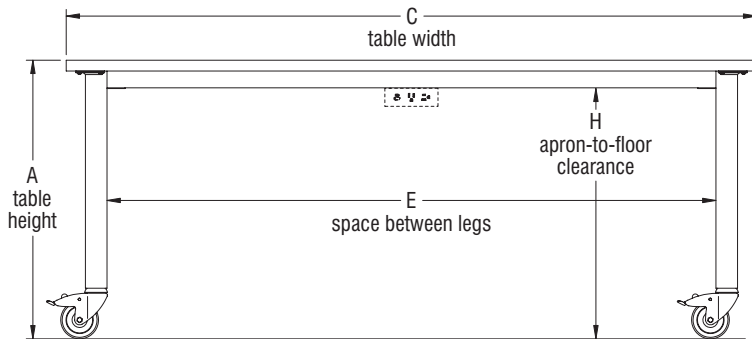

(front view)

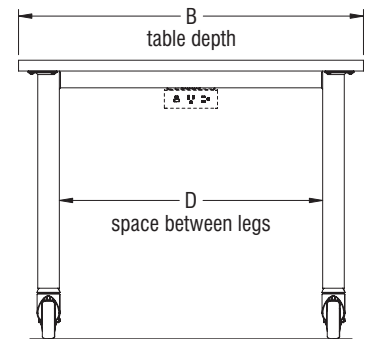

(side view)

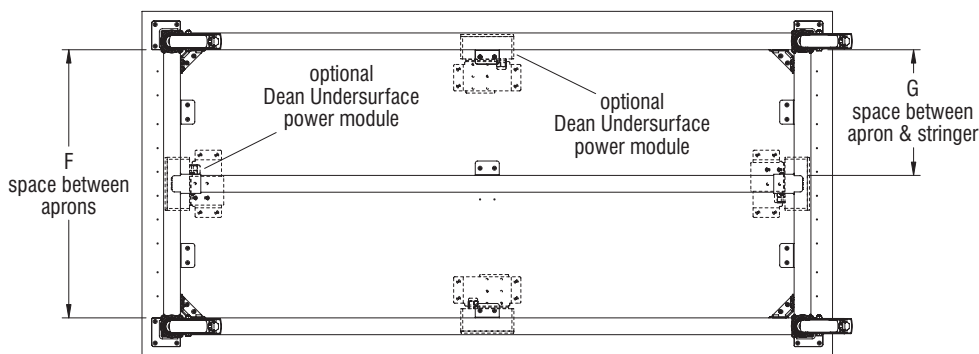

(bottom view)

**Note:** Table height dimensions in the chart above represent tables using a 1/4" thick laminate worksurface. Tables using a 1" thick phenolic resin worksurface must subtract 1/4" from the "table height" column in the chart. Tables using a 3/4" thick butcher block wood worksurface must add 1/2" to the "table height" column in the chart. Tables using a 1/2" thick stainless steel worksurface must add 1/4" to the "table height" column in the chart.

# DIMENSIONS

## Stout 36" Fixed-Height Tables with Casters

Model Number	A Table Height	B Table Depth	C Table Width	D Space Between Legs	E Space Between Legs	F Space Between Aprons	G Space Between Apron & Stringer	H Apron-to-Floor Clearance
SUEBA3048	36"	29.93"	47.93"	21.43"	39.43"	21.93"	N/A	33.10"
SUEBA3060	36"	29.93"	59.93"	21.43"	51.43"	21.93"	N/A	33.10"
SUEBA3072	36"	29.93"	71.93"	21.43"	63.43"	21.93"	N/A	33.10"
SUEBA3084	36"	29.93"	83.93"	21.43"	75.43"	21.93"	N/A	33.10"
SUEBA3648	36"	35.93"	47.93"	27.43"	39.43"	N/A	13.09"	33.10"
SUEBA3660	36"	35.93"	59.93"	27.43"	51.43"	N/A	13.09"	33.10"
SUEBA3672	36"	35.93"	71.93"	27.43"	63.43"	N/A	13.09"	33.10"
SUEBA3684	36"	35.93"	83.93"	27.43"	75.43"	N/A	13.09"	33.10"
SUEBA4248	36"	41.93"	47.93"	33.43"	39.43"	N/A	16.09"	33.10"
SUEBA4260	36"	41.93"	59.93"	33.43"	51.43"	N/A	16.09"	33.10"
SUEBA4272	36"	41.93"	71.93"	33.43"	63.43"	N/A	16.09"	33.10"
SUEBA4284	36"	41.93"	83.93"	33.43"	75.43"	N/A	16.09"	33.10"
SUEBA4848	36"	47.93"	47.93"	39.43"	39.43"	N/A	19.09"	33.10"
SUEBA4860	36"	47.93"	59.93"	39.43"	51.43"	N/A	19.09"	33.10"
SUEBA4872	36"	47.93"	71.93"	39.43"	63.43"	N/A	19.09"	33.10"
SUEBA4884	36"	47.93"	83.93"	39.43"	75.43"	N/A	19.09"	33.10"

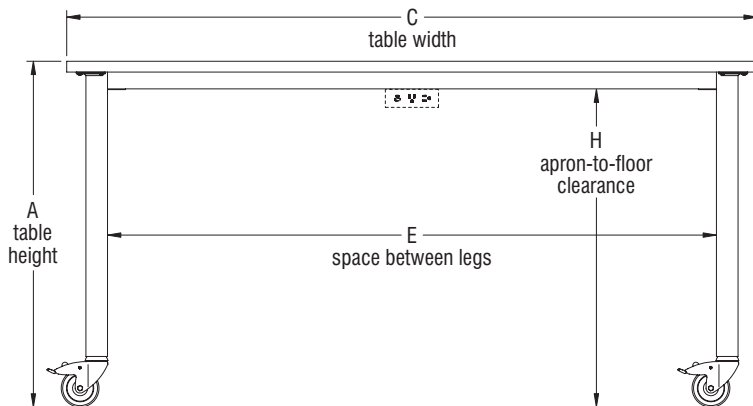

(front view)

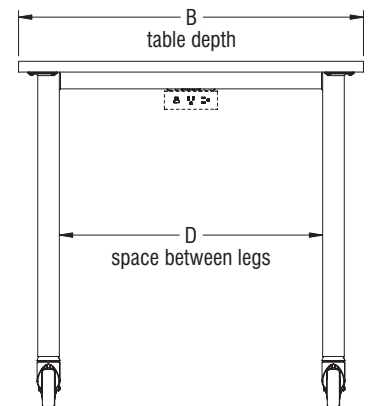

(side view)

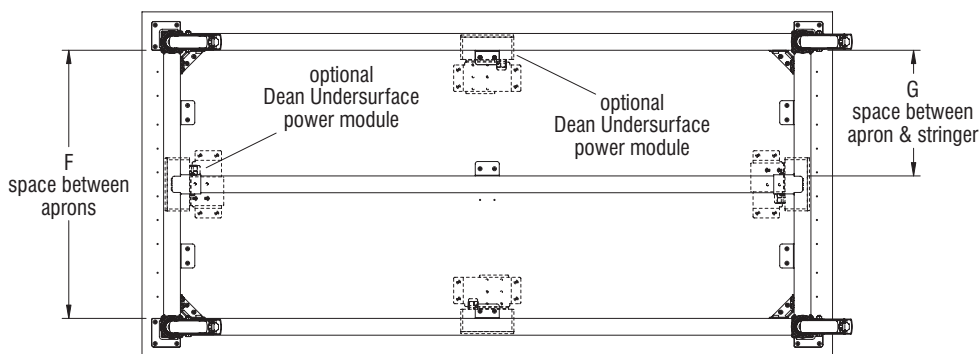

(bottom view)

**Note:** Table height dimensions in the chart above represent tables using a 1<sup>1</sup>/<sub>4</sub>" thick laminate worksurface. Tables using a 1" thick phenolic resin worksurface must subtract 1<sup>1</sup>/<sub>4</sub>" from the "table height" column in the chart. Tables using a 1<sup>3</sup>/<sub>4</sub>" thick butcher block wood worksurface must add 1<sup>1</sup>/<sub>2</sub>" to the "table height" column in the chart. Tables using a 1<sup>1</sup>/<sub>2</sub>" thick stainless steel worksurface must add 1<sup>1</sup>/<sub>4</sub>" to the "table height" column in the chart.

# DIMENSIONS

## Stout 40" Fixed-Height Tables with Casters

Model Number	A Table Height	B Table Depth	C Table Width	D Space Between Legs	E Space Between Legs	F Space Between Aprons	G Space Between Apron & Stringer	H Apron-to-Floor Clearance
SUEKA3048	40"	29.93"	47.93"	21.43"	39.43"	21.93"	N/A	37.10"
SUEKA3060	40"	29.93"	59.93"	21.43"	51.43"	21.93"	N/A	37.10"
SUEKA3072	40"	29.93"	71.93"	21.43"	63.43"	21.93"	N/A	37.10"
SUEKA3084	40"	29.93"	83.93"	21.43"	75.43"	21.93"	N/A	37.10"
SUEKA3648	40"	35.93"	47.93"	27.43"	39.43"	N/A	13.09"	37.10"
SUEKA3660	40"	35.93"	59.93"	27.43"	51.43"	N/A	13.09"	37.10"
SUEKA3672	40"	35.93"	71.93"	27.43"	63.43"	N/A	13.09"	37.10"
SUEKA3684	40"	35.93"	83.93"	27.43"	75.43"	N/A	13.09"	37.10"
SUEKA4248	40"	41.93"	47.93"	33.43"	39.43"	N/A	16.09"	37.10"
SUEKA4260	40"	41.93"	59.93"	33.43"	51.43"	N/A	16.09"	37.10"
SUEKA4272	40"	41.93"	71.93"	33.43"	63.43"	N/A	16.09"	37.10"
SUEKA4284	40"	41.93"	83.93"	33.43"	75.43"	N/A	16.09"	37.10"
SUEKA4848	40"	47.93"	47.93"	39.43"	39.43"	N/A	19.09"	37.10"
SUEKA4860	40"	47.93"	59.93"	39.43"	51.43"	N/A	19.09"	37.10"
SUEKA4872	40"	47.93"	71.93"	39.43"	63.43"	N/A	19.09"	37.10"
SUEKA4884	40"	47.93"	83.93"	39.43"	75.43"	N/A	19.09"	37.10"

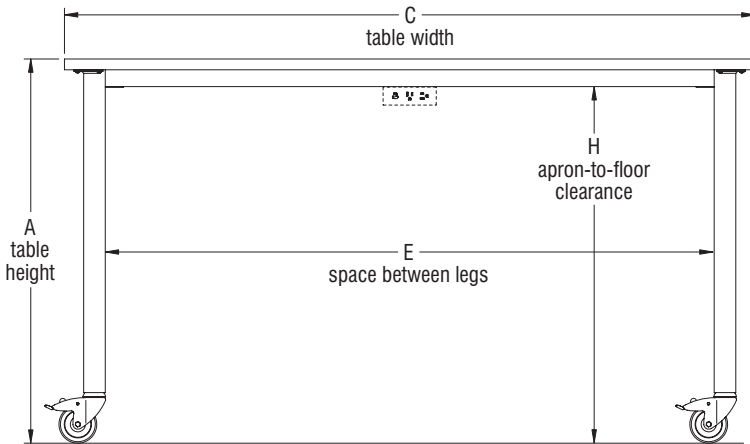

(front view)

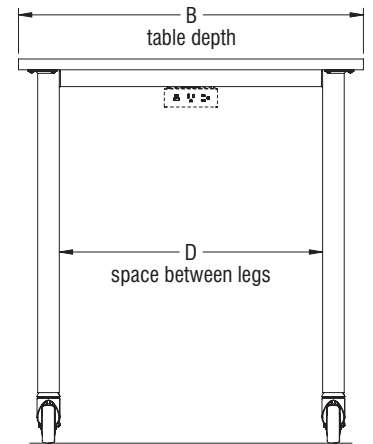

(side view)

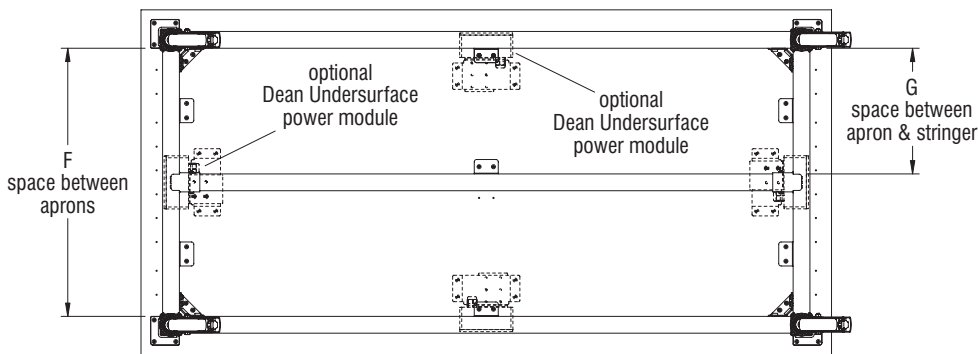

(bottom view)

**Note:** Table height dimensions in the chart above represent tables using a 1 1/4" thick laminate worksurface. Tables using a 1" thick phenolic resin worksurface must subtract 1/4" from the "table height" column in the chart. Tables using a 1 3/4" thick butcher block wood worksurface must add 1/2" to the "table height" column in the chart. Tables using a 1 1/2" thick stainless steel worksurface must add 1/4" to the "table height" column in the chart.

## DIMENSIONS

### Stout Adjustable-Height Tables with Casters

Model Number	A Table Height	B Table Depth	C Table Width	D Space Between Legs	E Space Between Legs	F Space Between Aprons	G Space Between Apron & Stringer	H Apron-to-Floor Clearance
SUEFA3048	27" - 40"	29.93"	47.93"	21.43"	39.43"	21.93"	N/A	24.10" - 37.10"
SUEFA3060	27" - 40"	29.93"	59.93"	21.43"	51.43"	21.93"	N/A	24.10" - 37.10"
SUEFA3072	27" - 40"	29.93"	71.93"	21.43"	63.43"	21.93"	N/A	24.10" - 37.10"
SUEFA3084	27" - 40"	29.93"	83.93"	21.43"	75.43"	21.93"	N/A	24.10" - 37.10"
SUEFA3648	27" - 40"	35.93"	47.93"	27.43"	39.43"	N/A	13.09"	24.10" - 37.10"
SUEFA3660	27" - 40"	35.93"	59.93"	27.43"	51.43"	N/A	13.09"	24.10" - 37.10"
SUEFA3672	27" - 40"	35.93"	71.93"	27.43"	63.43"	N/A	13.09"	24.10" - 37.10"
SUEFA3684	27" - 40"	35.93"	83.93"	27.43"	75.43"	N/A	13.09"	24.10" - 37.10"
SUEFA4248	27" - 40"	41.93"	47.93"	33.43"	39.43"	N/A	16.09"	24.10" - 37.10"
SUEFA4260	27" - 40"	41.93"	59.93"	33.43"	51.43"	N/A	16.09"	24.10" - 37.10"
SUEFA4272	27" - 40"	41.93"	71.93"	33.43"	63.43"	N/A	16.09"	24.10" - 37.10"
SUEFA4284	27" - 40"	41.93"	83.93"	33.43"	75.43"	N/A	16.09"	24.10" - 37.10"
SUEFA4848	27" - 40"	47.93"	47.93"	39.43"	39.43"	N/A	19.09"	24.10" - 37.10"
SUEFA4860	27" - 40"	47.93"	59.93"	39.43"	51.43"	N/A	19.09"	24.10" - 37.10"
SUEFA4872	27" - 40"	47.93"	71.93"	39.43"	63.43"	N/A	19.09"	24.10" - 37.10"
SUEFA4884	27" - 40"	47.93"	83.93"	39.43"	75.43"	N/A	19.09"	24.10" - 37.10"

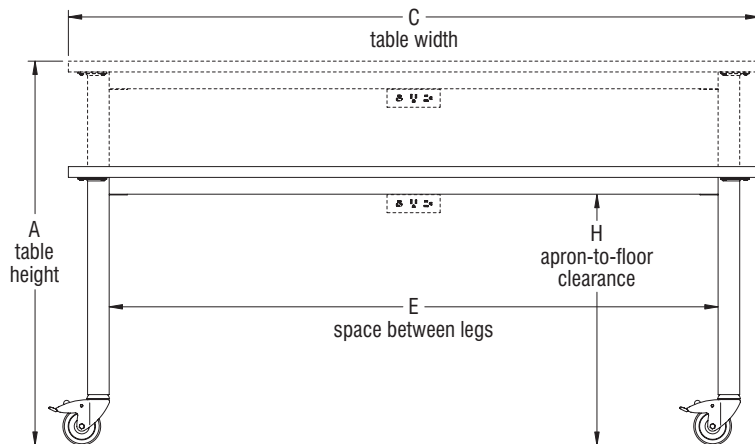

(front view)

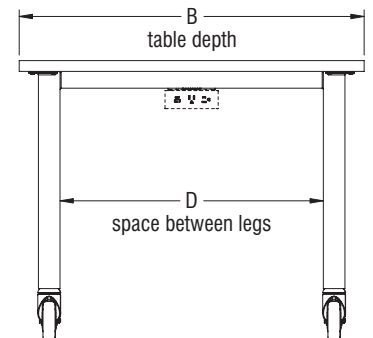

(side view)

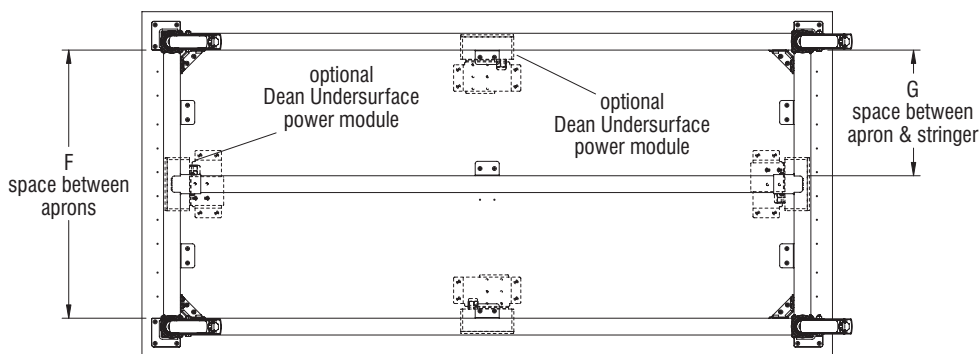

(bottom view)

**Note:** Table height dimensions in the chart above represent tables using a 1<sup>1</sup>/<sub>4</sub>" thick laminate worksurface. Tables using a 1" thick phenolic resin worksurface must subtract 1<sup>1</sup>/<sub>4</sub>" from the "table height" column in the chart. Tables using a 1<sup>3</sup>/<sub>4</sub>" thick butcher block wood worksurface must add 1<sup>1</sup>/<sub>2</sub>" to the "table height" column in the chart. Tables using a 1<sup>1</sup>/<sub>2</sub>" thick stainless steel worksurface must add 1<sup>1</sup>/<sub>4</sub>" to the "table height" column in the chart.

# DIMENSIONS

## Stout Adjustable-Height Tables with Glides

Model Number	A Table Height	B Table Depth	C Table Width	D Space Between Legs	E Space Between Legs	F Space Between Aprons	G Space Between Apron & Stringer	H Apron-to-Floor Clearance
SUEFA2448	27" - 40"	23.93"	47.93"	15.43"	39.43"	15.93"	N/A	24.10" - 37.10"
SUEFA2460	27" - 40"	23.93"	59.93"	15.43"	51.43"	15.93"	N/A	24.10" - 37.10"
SUEFA2472	27" - 40"	23.93"	71.93"	15.43"	63.43"	15.93"	N/A	24.10" - 37.10"
SUEFA3048	27" - 40"	29.93"	47.93"	21.43"	39.43"	21.93"	N/A	24.10" - 37.10"
SUEFA3060	27" - 40"	29.93"	59.93"	21.43"	51.43"	21.93"	N/A	24.10" - 37.10"
SUEFA3072	27" - 40"	29.93"	71.93"	21.43"	63.43"	21.93"	N/A	24.10" - 37.10"
SUEFA3084	27" - 40"	29.93"	83.93"	21.43"	75.43"	21.93"	N/A	24.10" - 37.10"
SUEFA3648	27" - 40"	35.93"	47.93"	27.43"	39.43"	N/A	13.09"	24.10" - 37.10"
SUEFA3660	27" - 40"	35.93"	59.93"	27.43"	51.43"	N/A	13.09"	24.10" - 37.10"
SUEFA3672	27" - 40"	35.93"	71.93"	27.43"	63.43"	N/A	13.09"	24.10" - 37.10"
SUEFA3684	27" - 40"	35.93"	83.93"	27.43"	75.43"	N/A	13.09"	24.10" - 37.10"
SUEFA4248	27" - 40"	41.93"	47.93"	33.43"	39.43"	N/A	16.09"	24.10" - 37.10"
SUEFA4260	27" - 40"	41.93"	59.93"	33.43"	51.43"	N/A	16.09"	24.10" - 37.10"
SUEFA4272	27" - 40"	41.93"	71.93"	33.43"	63.43"	N/A	16.09"	24.10" - 37.10"
SUEFA4284	27" - 40"	41.93"	83.93"	33.43"	75.43"	N/A	16.09"	24.10" - 37.10"
SUEFA4848	27" - 40"	47.93"	47.93"	39.43"	39.43"	N/A	19.09"	24.10" - 37.10"
SUEFA4860	27" - 40"	47.93"	59.93"	39.43"	51.43"	N/A	19.09"	24.10" - 37.10"
SUEFA4872	27" - 40"	47.93"	71.93"	39.43"	63.43"	N/A	19.09"	24.10" - 37.10"
SUEFA4884	27" - 40"	47.93"	83.93"	39.43"	75.43"	N/A	19.09"	24.10" - 37.10"

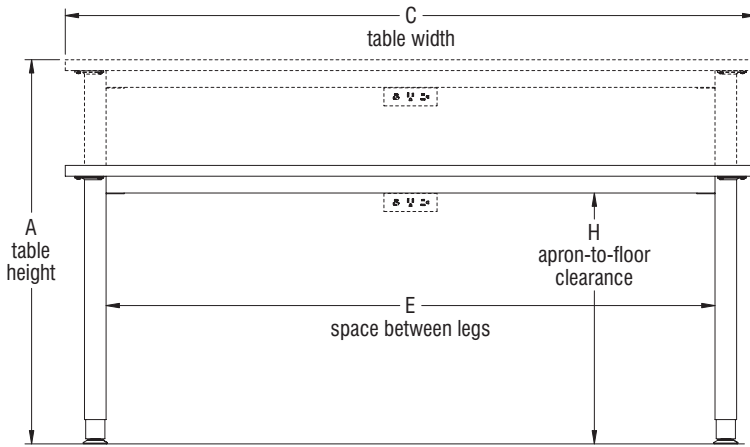

(front view)

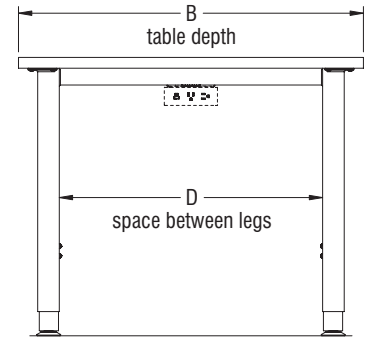

(side view)

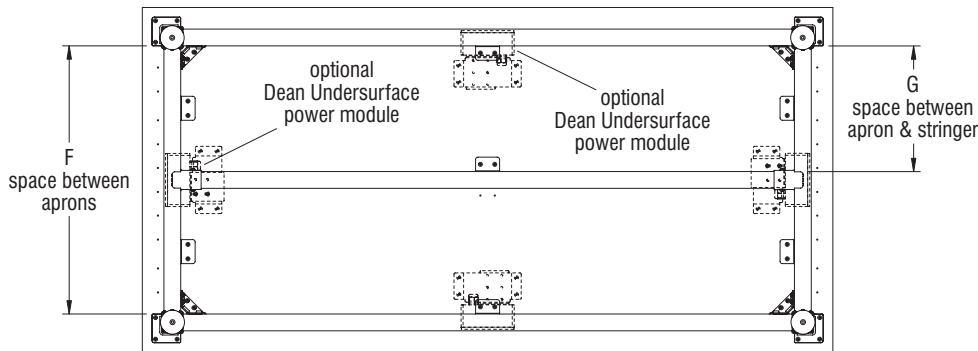

(bottom view)

**Note:** Table height dimensions in the chart above represent tables using a 1 1/4" thick laminate worksurface. Tables using a 1" thick phenolic resin worksurface must subtract 1/4" from the "table height" column in the chart. Tables using a 1 3/4" thick butcher block wood worksurface must add 1/2" to the "table height" column in the chart. Tables using a 1 1/2" thick stainless steel worksurface must add 1/4" to the "table height" column in the chart.

## DIMENSIONS

### Footrest Leg Clearance

All table frames are shipped K.D. (knocked-down) and require assembly in the field.

## CODE COMPLIANCE

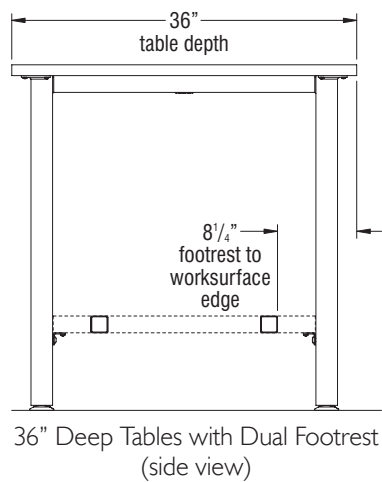
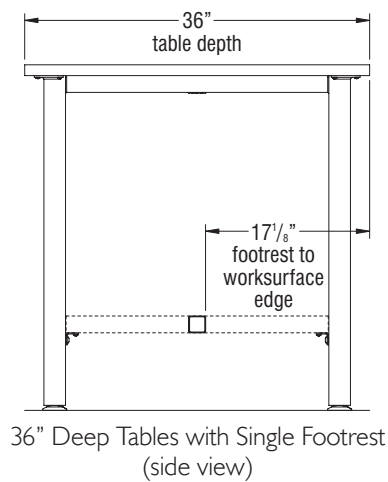
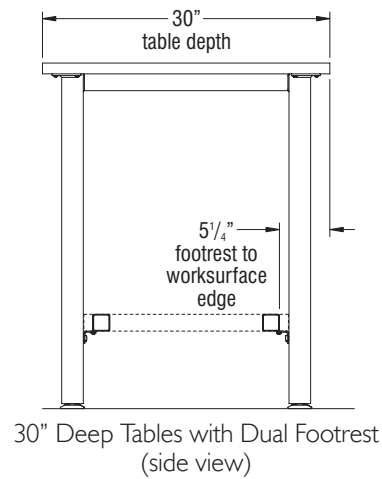
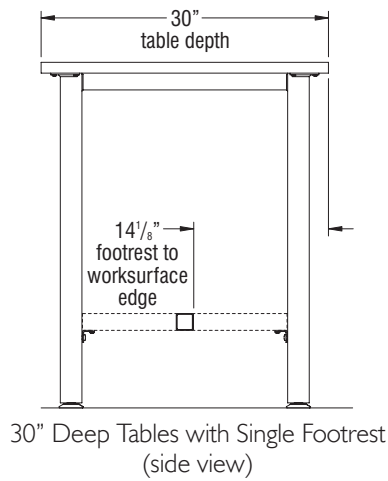
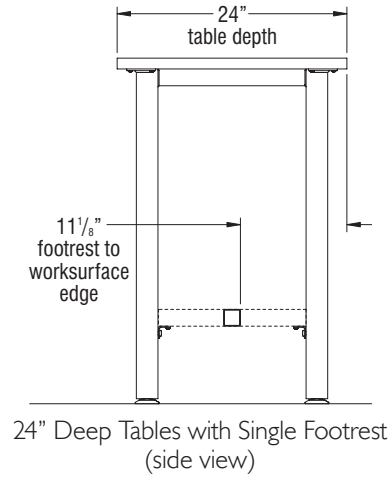

## DIMENSIONS

### Footrest Leg Clearance (cont.)

All table frames are shipped K.D. (knocked-down) and require assembly in the field.

## CODE COMPLIANCE

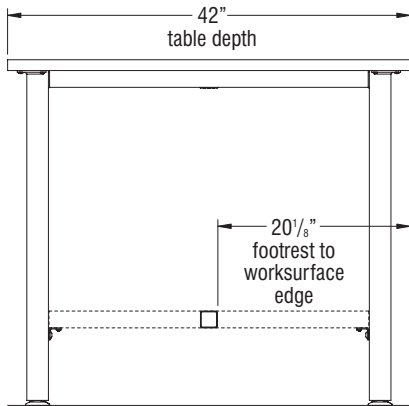

42" Deep Tables with Single Footrest  
(side view)

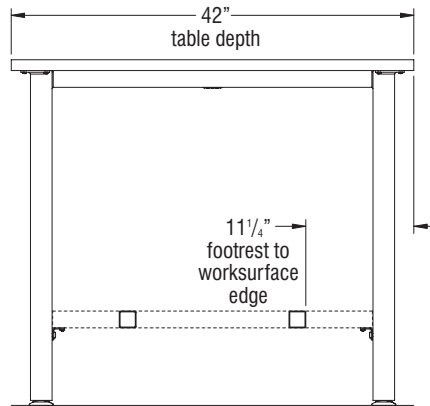

42" Deep Tables with Dual Footrest  
(side view)

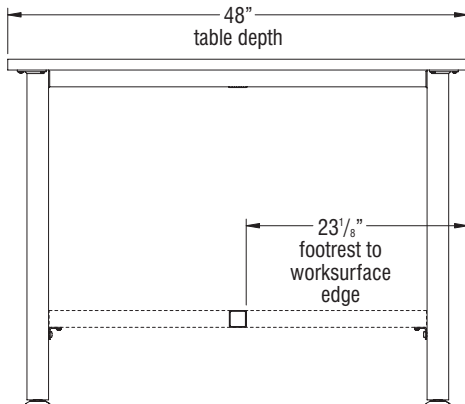

48" Deep Tables with Single Footrest  
(side view)

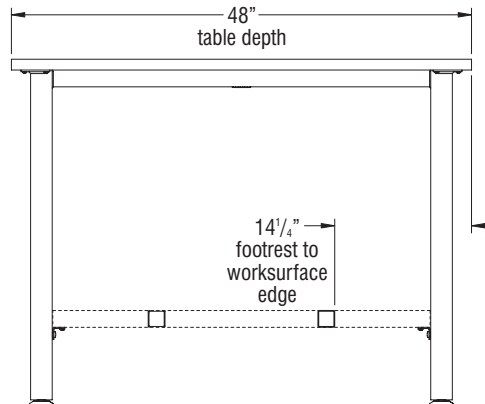

48" Deep Tables with Dual Footrest  
(side view)

## STATEMENT OF LINE

### Stout Tables - Fixed-Height Frames

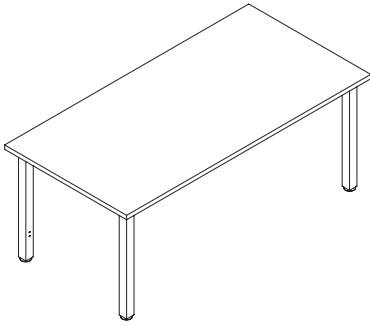

Fixed-Height Table with Glides  
SUEAA (29" Fixed-Height)  
SUEBA (36" Fixed-Height)  
SUEKA (40" Fixed-Height)

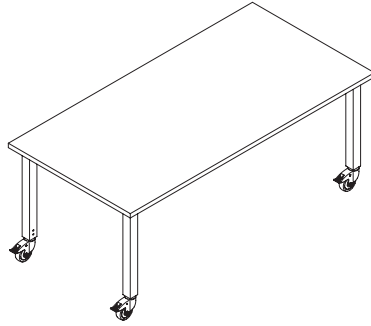

Fixed-Height Table with Casters  
SUEAA (29" Fixed-Height)  
SUEBA (36" Fixed-Height)  
SUEKA (40" Fixed-Height)

### Stout Tables - Adjustable-Height Frames

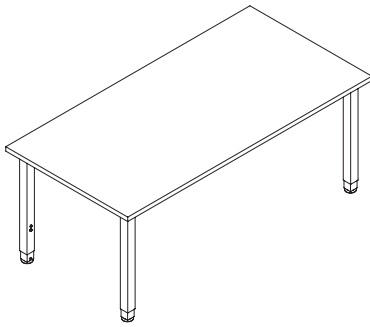

Adjustable-Height Table with Glides  
SUEFA (27"-40" Adjustable Height)

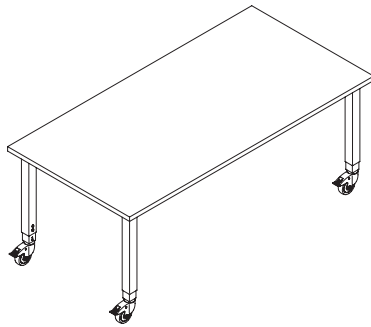

Adjustable-Height Table with Casters  
SUEFA (27"-40" Adjustable Height)

## CODE COMPLIANCE



# STATEMENT OF LINE

## Stout Table Accessories

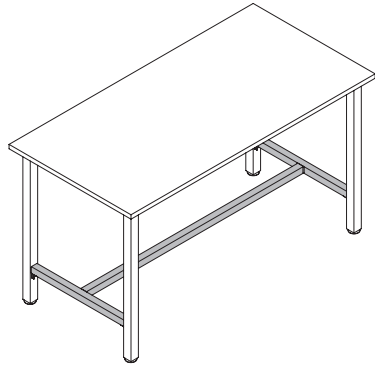

Single Footrest

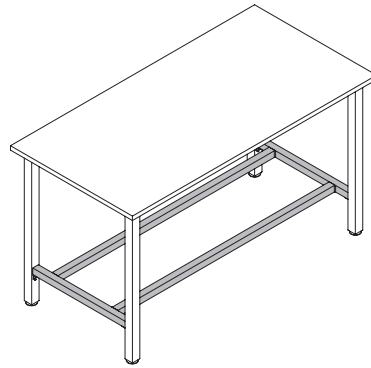

Dual Footrest

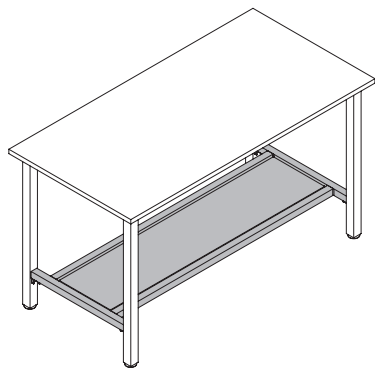

Dual Footrest with Shelf

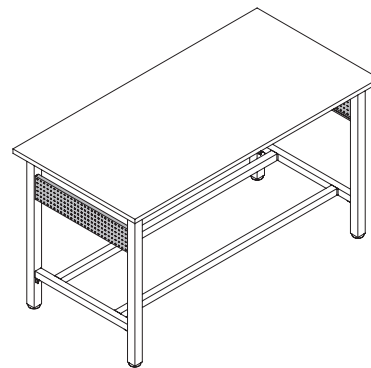

Pegboard End Panel

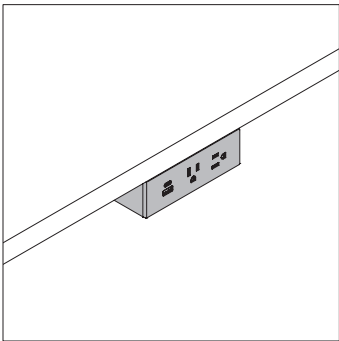

Dean Undersurface Power Module with 3-Prong Plug

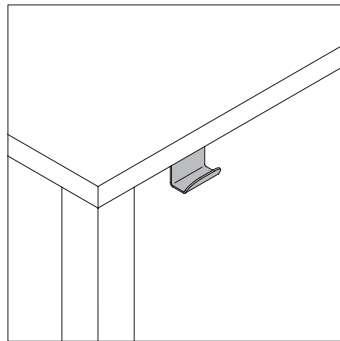

Undersurface Bag Hook

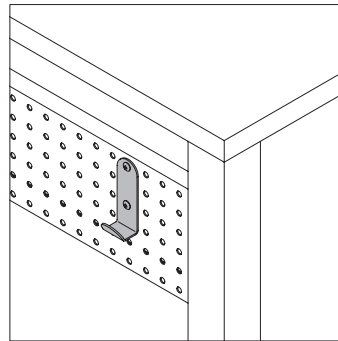

Pegboard Mounted Bag Hook

# CODE COMPLIANCE

