

■ Tattoo™ Screens - Table of Contents

Assembly Instructions

Tattoo™ Screens

Tools Required	3
Unloading	4
Flex and Spine Screen - Overview	5

Spine Screen

Spine Screen Foot Assembly	5
Leveling & Connecting Spine Screens	6
Leveling & Connecting Change of Height Spine Screens	8

Spine Screen Electrical

Electrical Installation - Overview	9
Duplex Receptacle Installation	9
Screen-to-Screen 10-Wire Jumper Installation	10
Pass-Through Screen-to-Screen 10-Wire Jumper Installation	11
10-Wire Top Power Infeed (End-of-Run) Installation	12
10-Wire Top Power Infeed (In-Line) Installation	14
10-Wire Top Power Infeed (In-Line) Installation with Flex Screen	16
Power Pole Extension Installation	19
10-Wire Base Power Infeed (End-of-Run) Installation	20
Base Raceway Power Infeed Installation	21
10-Wire Base Power Infeed Spacer (End-of-Run) Installation	22
10-Wire Base Power Infeed Spacer (In-Line) Installation	23
10-Wire Base Power Infeed Spacer (In-Line) Installation with Flex Screen Intersection	26
Hardwired Electrical Base Power Infeed Trim Installation	30
Data Installation	31

Spine Screen Trim

End-of-Run Spacer Installation	32
In-Line Spacer Installation	33
In-Line Spacer Installation with Flex Screen Intersection	34
10-Wire Base Trim Installation	38
End-of-Run Vertical Trim Installation	39
Change-of-Height Trim Installation	40
Flat Aluminum Top Cap Installation	41

Flex Screen Configurations

In-Line Flex Screens	42
Flex Screen Corner Intersections	43
Flex Screen Mid-Panel Intersections	44
Flex Screen 3-Way Intersections	45
Spine & Flex Screen 3-Way Intersections	46

Additional Information

Topper Kit Installation	47
Slide Panel Installation	48
Coat Hook Installation	49



Assemble units as described herein only. To do otherwise may result in instability. All screws, nuts and bolts must be tightened securely and must be checked periodically after assembly. Failure to assemble properly, or to secure parts may result in assembly failure and personal injury.

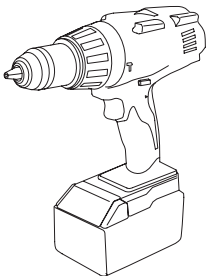

**Power Drill with
Magnetic Bit Holder**

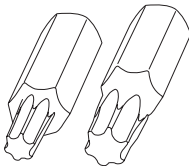

**Torx Bits
(T-25, T-30)**

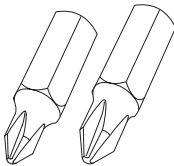

**Phillips Bits
(#2, #3)**

Tools Required

- Power Driver with Magnetic Bit Holder
- Drive Bits T-25, T-30 and Phillips
- Laser Level
- A Pair of Thin Flat Bars
- Utility Knife
- Tape Measure
- Miter Saw with Non-Ferrous Blade

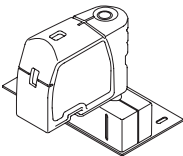

Laser Alignment Tool

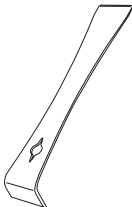

Flat Pry Bar

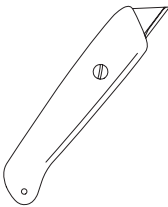

Utility Knife

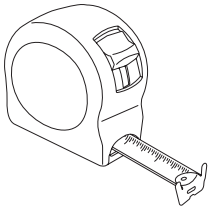

Tape Measure

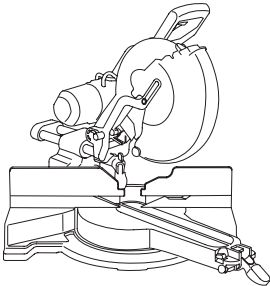

Miter Saw with Non-Ferrous Blade
Note: Cut station must be equipped with stands, tarps, and a shop vac.

■ Tattoo™ Screens - Unloading

Assembly Instructions



Assemble units as described herein only. To do otherwise may result in instability. All screws, nuts and bolts must be tightened securely and must be checked periodically after assembly. Failure to assemble properly, or to secure parts may result in assembly failure and personal injury.

Unloading

Warning: Shipping skids are designed to be moved with a pallet jack or slid along the floor using a fork lift. If no dock is available to remove the skid at grade from the bed of the trailer, the screens must be unloaded by hand one at a time. FAILURE TO COMPLY MAY RESULT IN DAMAGED PRODUCTS AND/OR INJURY.

1. It is highly recommended that the screens be removed and staged with protection between the screens. Lean the screens vertically against a wall at a slight angle. If screens must be leaned on edge, no more than 12 screens of like size should be in one leaning stack. Stack screens with the padding against the wall or on the floor to prevent damage.
2. As each screen or component is unloaded, it should be checked against the packing list and/or space-plan layout (shop drawing) to ensure completeness of order. All items are identified by both a part number sticker and a carton number sticker.
3. Inspect each panel for shipping damage as it is removed from the truck. If damage exists, notify KI of carton number, type of damage and probable cause of damage within 24 hours of unloading.
4. **Damage must be indicated on bill of lading to file a freight claim. Report all other on-site damage as soon as possible to ensure prompt replacements. To transport panels on site, use a well-padded drywall cart to eliminate damage of edges and finish.**





Assemble units as described herein only. To do otherwise may result in instability. All screws, nuts and bolts must be tightened securely and must be checked periodically after assembly. Failure to assemble properly, or to secure parts may result in assembly failure and personal injury.

Flex and Spine Screen - Overview

Note: Flex Screens ship mostly assembled, except for when topper accessories are specified. Spine Screens ship without base raceway trim and feet attached. Feet must be assembled to the bottom of each Spine Screen as they are unpacked.

Note: If Spine Screens are not being assembled, go now to "Flex Screen Configurations" instructions on page 42.

Important: If the Spine Screen System is to be installed with New York City electrical, proceed to the Tattoo Screen System - New York City Electrical Assembly Instruction (KI-AI-000045) before proceeding to "Spine Screen Foot Assembly" instructions on this page.

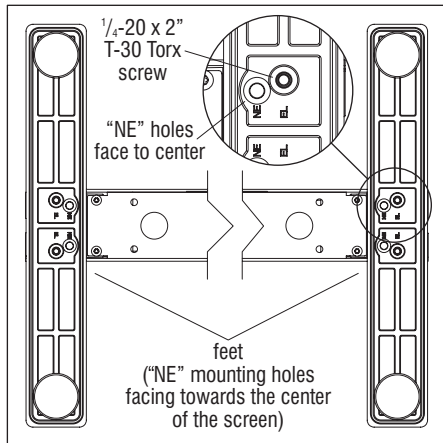

Detail A - Bottom View of Spine Screen

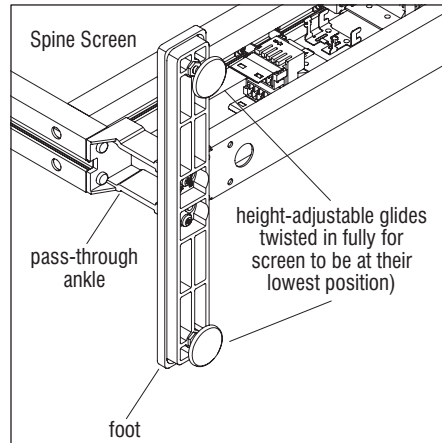

Detail B

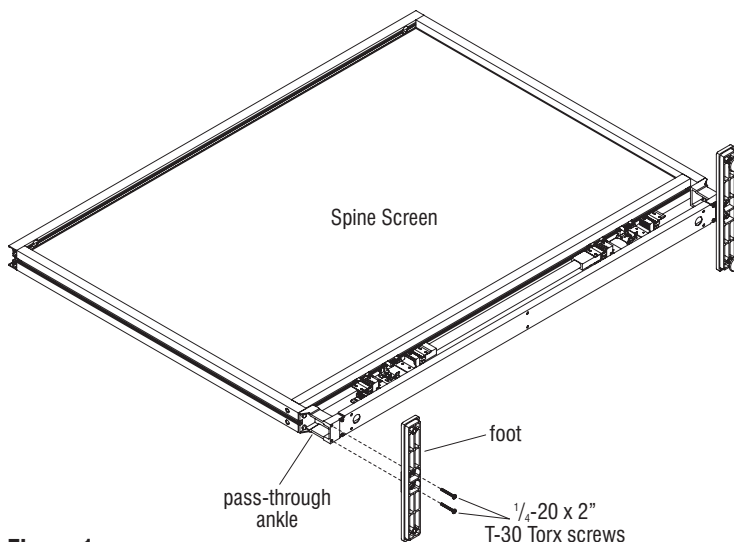

Figure 1

Spine Screen Foot Assembly

1. Carefully lay Spine Screen flat onto a soft, protective surface (Figure 1).

Note: An "EL" and "NE" are embossed on the bottom of each foot, corresponding to wider and narrower hole patterns respectively. Only the wider "EL" holes are used for mounting the feet to the Spine Screen pass-through ankle. But, the "NE" holes (narrower hole pattern) are referenced below to orient inward for correct installation of the foot. Take care and follow the directions below when positioning feet for installation. If feet are not installed in the correct orientation, screens will not gang in-line with each other and disassembly and correct re-assembly will be required.

2. Orient each foot such that the wider positioned "EL" mounting holes are to the outside of the Spine Screen unit and the narrower positioned "NE" holes are positioned closer to the center (Detail A), then position each foot over the corresponding mounting holes of the pass-through ankle. Secure each foot to the pass-through ankle using two 1/4-20 x 2" T-30 Torx screws (Figure 1 & Detail A).
3. Twist the height-adjustable glides in clock-wise, fully to the bottom of the foot. This will allow for upward adjustment of the screen, if required at the final installation location (Figure 1 & Detail B).

Tattoo™ Screens - Spine Screen Leveling & Connecting

Assembly Instructions



Assemble units as described herein only. To do otherwise may result in instability. All screws, nuts and bolts must be tightened securely and must be checked periodically after assembly. Failure to assemble properly, or to secure parts may result in assembly failure and personal injury.

Leveling & Connecting Spine Screens

Note: A single Spine Screen may not be used as a freestanding screen on its own. The Spine Screen must always be mechanically attached to another Spine Screen (with or without electrical).

1. Check to make sure all height-adjustable glides are adjusted so the screens are at their lowest position as illustrated in Detail F on page 8. If glides are not adjusted down fully to the bottom of the screen, reference "Spine Screen Foot Assembly" instructions on page 5, step 3.
2. Carefully turn Spine Screens to the upright position, and move to their final installation location in-line to each other per the space-planning layout (Figure 2).

Important: Know and mark all high and low spots on the floor. Make sure to twist adjustable glides appropriate to floor conditions. Always begin assembling screens together at the highest point of an un-even floor.

Note: If in-line Spine Screens include change-of-height screen(s), go now to "Leveling and Connecting Change-of-Height Spine Screens" instructions on page 8.

Using a laser alignment tool, determine and mark all high and low points on the floor. Adjust the level and height of the Spine Screen, beginning at the highest point in the floor first. To raise the screen, rotate the glide counter-clockwise. To lower the screen, rotate the glide clockwise. Only extend the glides as needed to make the screen level and plumb (Figure 2).

Note: If an in-line infeed power pole or spacer is specified between two screens, it must be installed between the designated screens before connecting the screens. If an in-line 10-wire top infeed power pole is to be installed, reference "10-Wire Top Power Infeed (In-Line) Installation"

instructions on page 14. If an in-line 10-wire top infeed power pole is to be installed with a Flex Screen intersection, reference "[10-Wire Top Power Infeed \(In-Line\) Installation with Flex Screen Intersection](#)" instructions on page 16. If an in-line 10-wire base infeed spacer is to be installed, reference "[10-Wire Base Power Infeed Spacer \(In-Line\) Installation](#)" instructions on page 24. If an in-line 10-wire base infeed spacer with a Flex Screen intersection is to be installed, reference "[10-Wire Base Power Infeed Spacer \(In-Line\) Installation with Flex Screen Intersection](#)" instructions on page 26. If an in-line spacer is to be installed, reference "[In-Line Spacer Installation](#)" instructions on page 33. If in-line spacer is to be installed with a flex screen intersection, reference "[In-Line Spacer Installation with Flex Screen Intersection](#)" instructions on page 34. After the spacer or in-line infeed power pole has been installed, proceed to step 4 on this page to connect Spine Screens.

3. Locate the bottom screen connector (Detail C) and take note that it contains two molding clips installed, one at each side. Figure 2 shows the molding clips separated

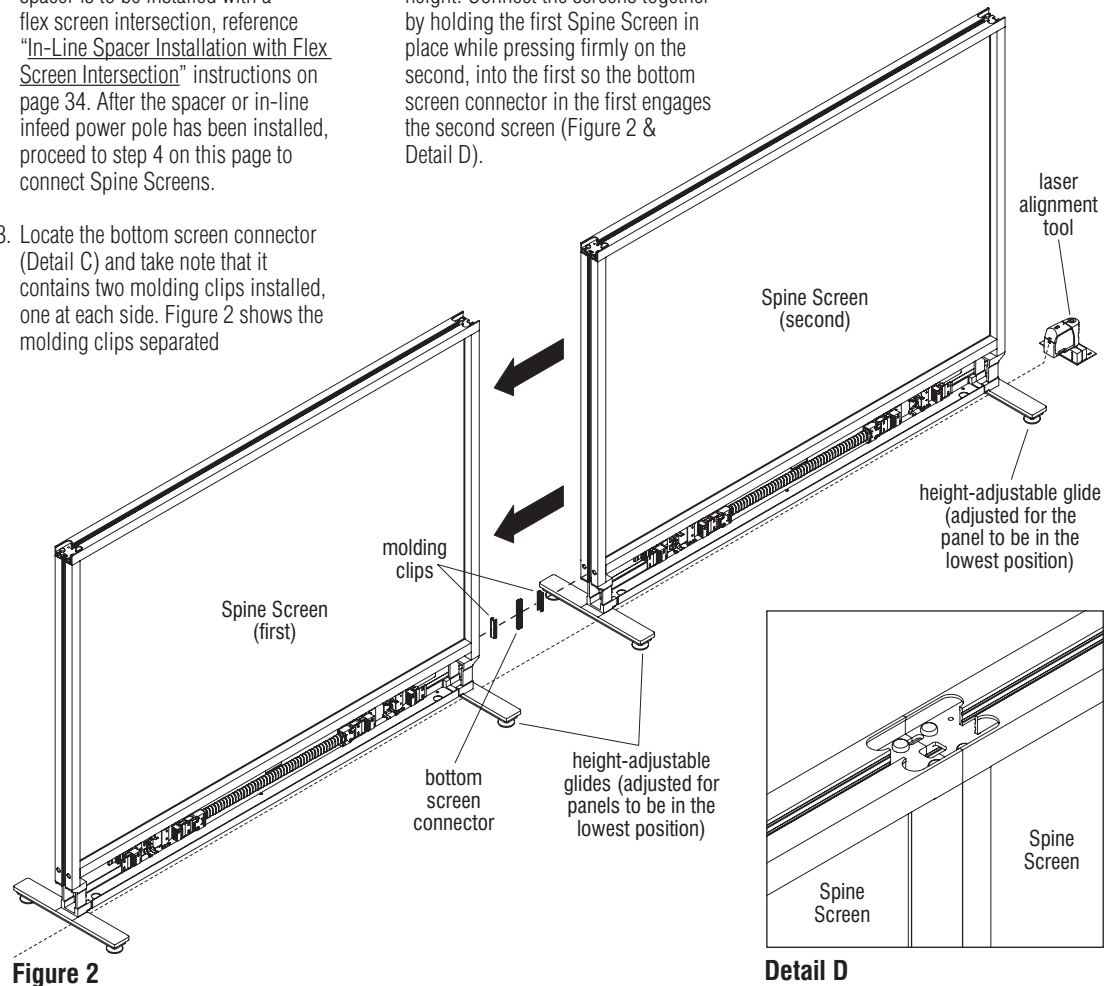
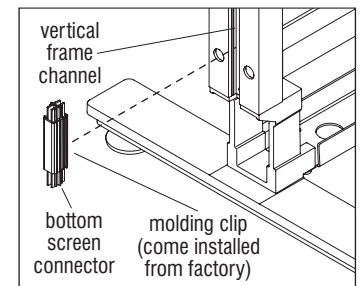

Figure 2

for clarity. Each clip will press-fit into the appropriate screen's channel to help join screens together. Assure that the first Spine Screen is level and plumb, and at its final installation location. Position the bottom screen connector up to the bottom of the vertical channel of the first Spine Screen and firmly press it in, oriented as shown (Figure 2 & Detail C).

4. Position the second Spine Screen in-line against the first Spine Screen, which has been adjusted level and plumb. Level and plumb the second screen to the first screen by twisting the height-adjustable glides clockwise or counter-clockwise until the frame's vertical edges are aligned and tops of screens are at the same height. Connect the screens together by holding the first Spine Screen in place while pressing firmly on the second, into the first so the bottom screen connector in the first engages the second screen (Figure 2 & Detail D).

5. Repeat the process in steps 4 & 5 to add, level, plumb and connect the remaining screens in the row. If the remaining screens to be connected are different heights, go now to "Leveling & Connecting Change-of-Height Spine Screens" instructions on page 8, step 2.



Detail C

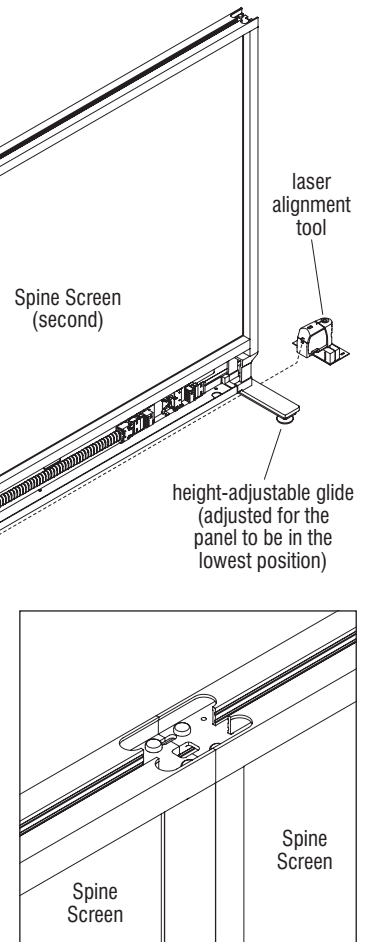

Detail D



Assemble units as described herein only. To do otherwise may result in instability. All screws, nuts and bolts must be tightened securely and must be checked periodically after assembly. Failure to assemble properly, or to secure parts may result in assembly failure and personal injury.

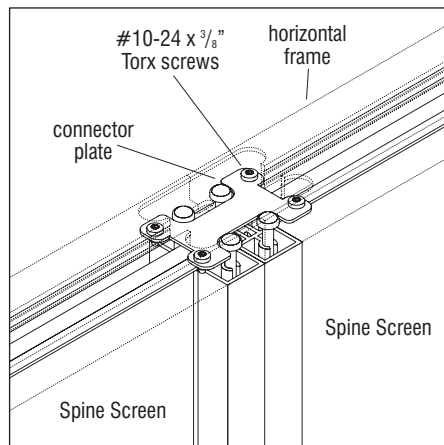

Detail E

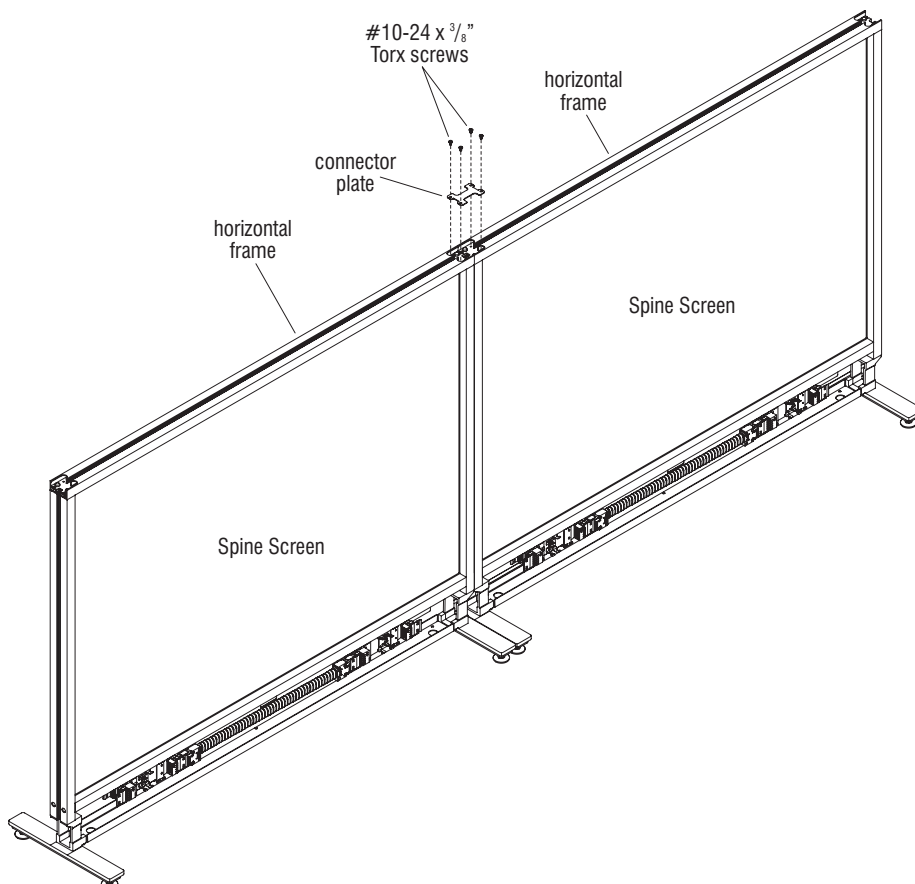

Figure 3

6. Ensure that the two in-line Spine Screens to be joined are tight to each other and properly aligned plumb and level. If screens are not plumb and level to each other, reference "Leveling & Connecting Spine Screens" instructions on page 6.
7. At the location where two in-line screens will be joined at the top, place a connector plate over the notch in both horizontal frames. Bridge the frames with the connector plate and align the four mounting holes in the screens with the mounting holes in the connector plate. Secure the plate to the screen's horizontal frame using four #10-24 x 3/8" Torx screws (Figure 3 & Detail E).

Note: Do not install any trim at this time. Trim is last to be installed, at a later time.

Tattoo™ Screens - Spine Screen Leveling & Connecting

Assembly Instructions



Assemble units as described herein only. To do otherwise may result in instability. All screws, nuts and bolts must be tightened securely and must be checked periodically after assembly. Failure to assemble properly, or to secure parts may result in assembly failure and personal injury.

Leveling & Connecting Change-of-Height Spine Screens

Note: A single Spine Screen may not be used as a freestanding screen on its own. The Spine Screen must always be mechanically attached to another Spine Screen (with or without electrical).

Important: Know and mark all high and low spots on the floor. Make sure to twist adjustable glides appropriate to floor conditions. Always begin assembling screens together at the highest point of an un-even floor.

- Using a laser alignment tool, determine and mark all high and low points on the floor. Adjust the level and height of the Spine Screen, beginning at the highest point in the floor first. To raise the screen, rotate the glide counter-clockwise. To lower the screen, rotate the screw clockwise. Only extend the glides as needed to make the screen level and plumb (Figure 4 & Detail F).
- Locate the screen connector (Detail G) and take note that it contains eight molding clips installed, four at each side. Figure 4 shows the molding clips separated for clarity. Each clip will press-fit into the appropriate screen's channel to help join screens together. Assure that the first Spine Screen is level and plumb, and at its final installation location. Position the bottom screen connector up to the bottom of the vertical channel of the first Spine Screen and firmly press it in, oriented as shown (Figure 4 & Detail G).
- Position the second Spine Screen in-line against the first Spine Screen, which has been adjusted level and plumb. Level and plumb the second screen to the first screen by twisting the height-adjustable glides clockwise or counter-clockwise until the frame's vertical edges are aligned. Connect the screens together by holding the first Spine Screen in place while pressing firmly on the second, into the first so the screen connector in the first engages the second screen (Figure 4 & Detail H).

- Repeat the process in steps 2 & 3 to add, level, plumb and connect the remaining change-of-height screens in the row. If the remaining screens to be connected are the same height, go now to "Leveling & Connecting Spine Screens" instructions on page 6, step 4.

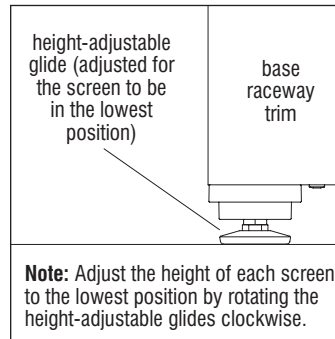

Detail F - Side View of Screen

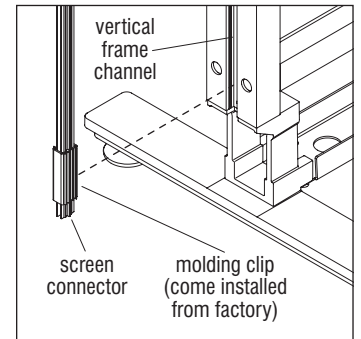

Detail G

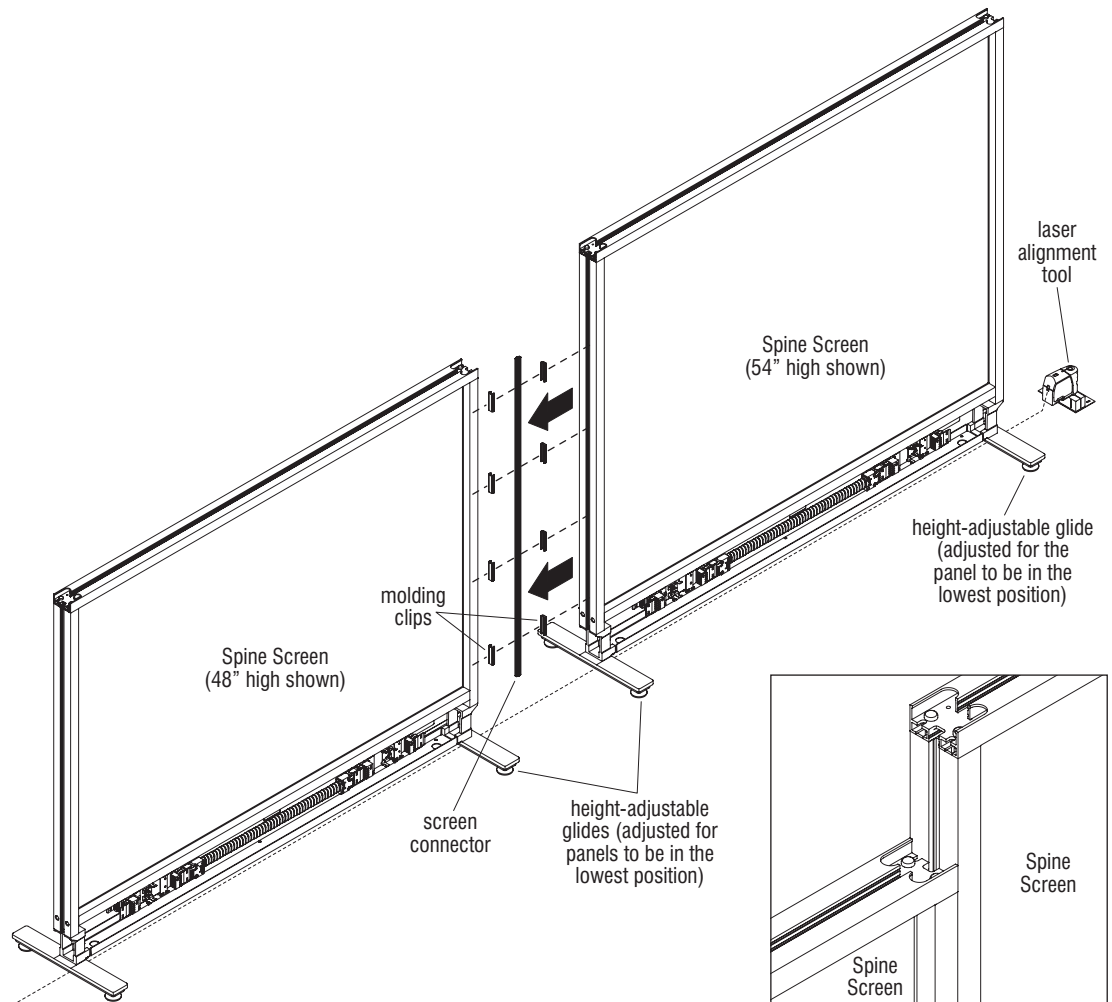
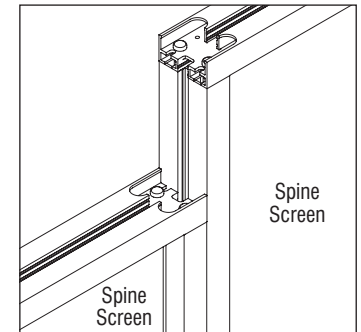

Figure 4



Detail H



Assemble units as described herein only. To do otherwise may result in instability. All screws, nuts and bolts must be tightened securely and must be checked periodically after assembly. Failure to assemble properly, or to secure parts may result in assembly failure and personal injury.

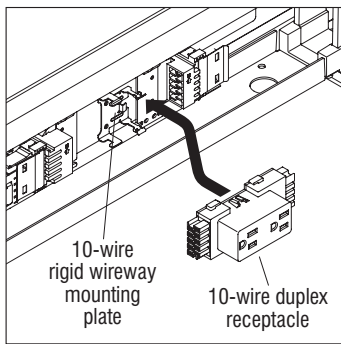

Detail I

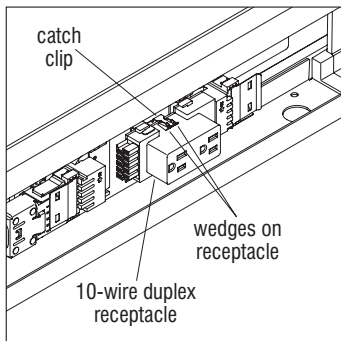

Detail K

Electrical Installation - Overview

Important: Assembly of all frame components must be completed, with screen frames properly leveled and mechanically secured to each

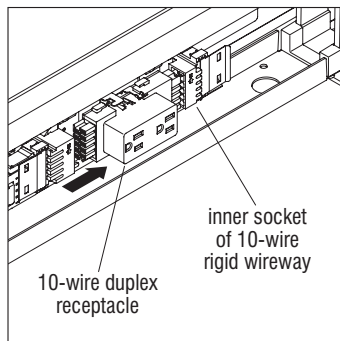

Detail J

other prior to installation of electrical components.

Connection to the building power supply may be made ONLY after all screen wiring has been completed. Building connections must be made by a licensed electrician, following local codes at the building site.

Note: Each circuit must be individually protected with a 120-volt, 20-amp circuit breaker device which will provide disconnect and overload protection.

Prior to beginning electrical component installation, read and understand the following electrical installation section and be familiar with the electrical components and all power infeed locations required.

Note: Each powered Spine Screen has two 10-wire rigid wireways that are pre-wired in the base raceway at the factory.

Note: Spine Screen electrical is "in-line" only and does not turn corners. Spine Screens cannot pass power to Flex Screens.

Duplex Receptacle Installation

Note: Duplex receptacles for the 10-wire system are specified/ordered separately. Six receptacles are available for accessing one of each of the six circuits of the 10-wire system. They are designed with a numeral on each (i.e. 1, 2, 3, 4, 5, & 6). Circuits 4, 5 and 6 have triangles to identify them as isolated circuits. To install the receptacles, follow the steps below.

WARNING: Assembly of all mechanical components must be completed before making any electrical connections. All electrically connected furnishings must also be mechanically connected.

1. Per the space-planning layout, determine the correct location for each numbered receptacle in the system (Figure 5).
2. Position the duplex receptacle on either end of the 10-wire rigid wireway as shown, matching the arrow at the "N" symbol to the same orientation on both the receptacle and the wireway (Figure 5).
3. Align the receptacle so the end is in-line with the inner socket on the rigid wireway and push the receptacle back against the mounting plate (Detail I).
4. Slide the receptacle to the side so the end terminals slide into the rigid wireway's inner socket (Detail J).
5. Receptacle is properly seated when the catch clip on the wireway is snapped in between the wedges on the receptacle (Detail K).

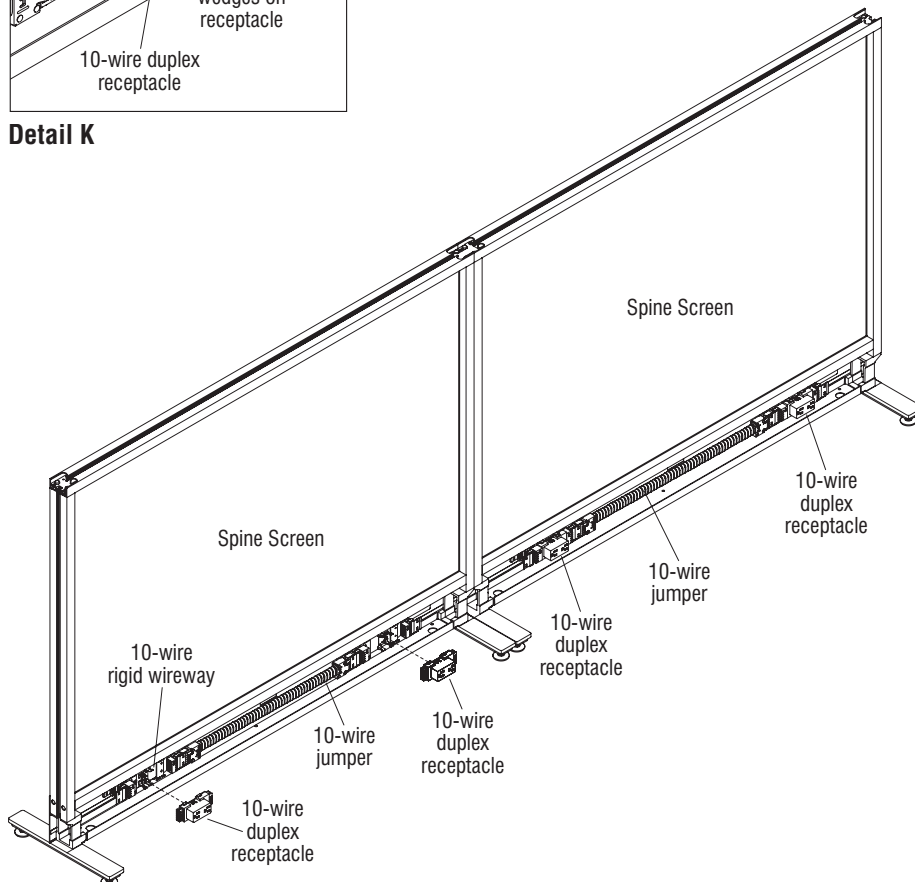

Figure 5

■ Tattoo™ Screens - Spine Screen 10-Wire Power Assembly Instructions



Assemble units as described herein only. To do otherwise may result in instability. All screws, nuts and bolts must be tightened securely and must be checked periodically after assembly. Failure to assemble properly, or to secure parts may result in assembly failure and personal injury.

Screen-to-Screen 10-Wire Jumper Installation

Note: Screen-to-screen jumpers pass power between the pre-mounted 10-wire rigid wireways, through the pass-through ankles, from one screen to another. Screen-to-screen jumpers are 17³/₄" long.

1. At the location specified for a screen-to-screen jumper, route the jumper through the pass-through ankles, then plug the ends into each rigid wireway (Figure 6 & Detail L).

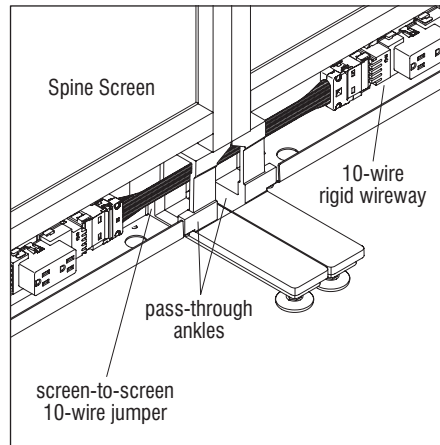

Detail L

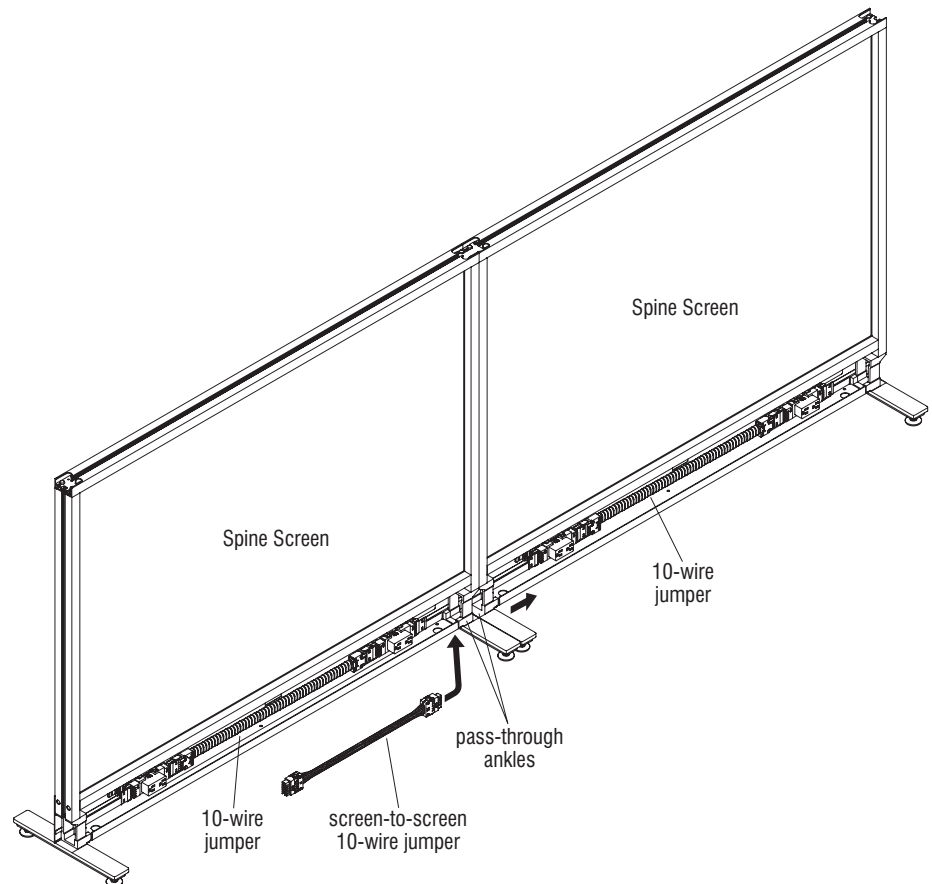
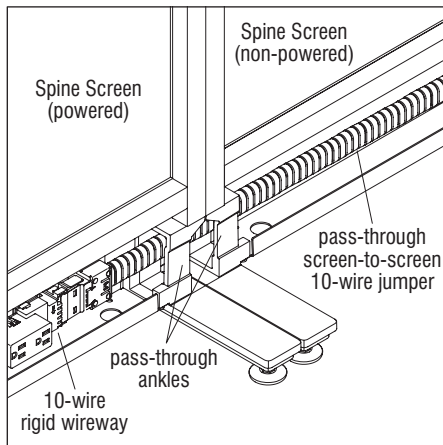

Figure 6



Assemble units as described herein only. To do otherwise may result in instability. All screws, nuts and bolts must be tightened securely and must be checked periodically after assembly. Failure to assemble properly, or to secure parts may result in assembly failure and personal injury.



Detail M

Pass-Through Screen-to-Screen 10-Wire Jumper Installation

Note: Pass-through screen-to-screen jumpers pass power from one powered Spine Screen through an unpowered Spine Screen to another powered Spine Screen. Pass-through screen-to-screen jumpers length are equal to the length of the non-powered Spine Screen plus an additional 17³/₄".

1. At the location specified for a pass-through screen-to-screen jumper, route the jumper through the pass-through ankles at each end of the non-powered screen, then plug the ends into each rigid wireway of the powered Spine Screens (Figure 7 & Detail M).

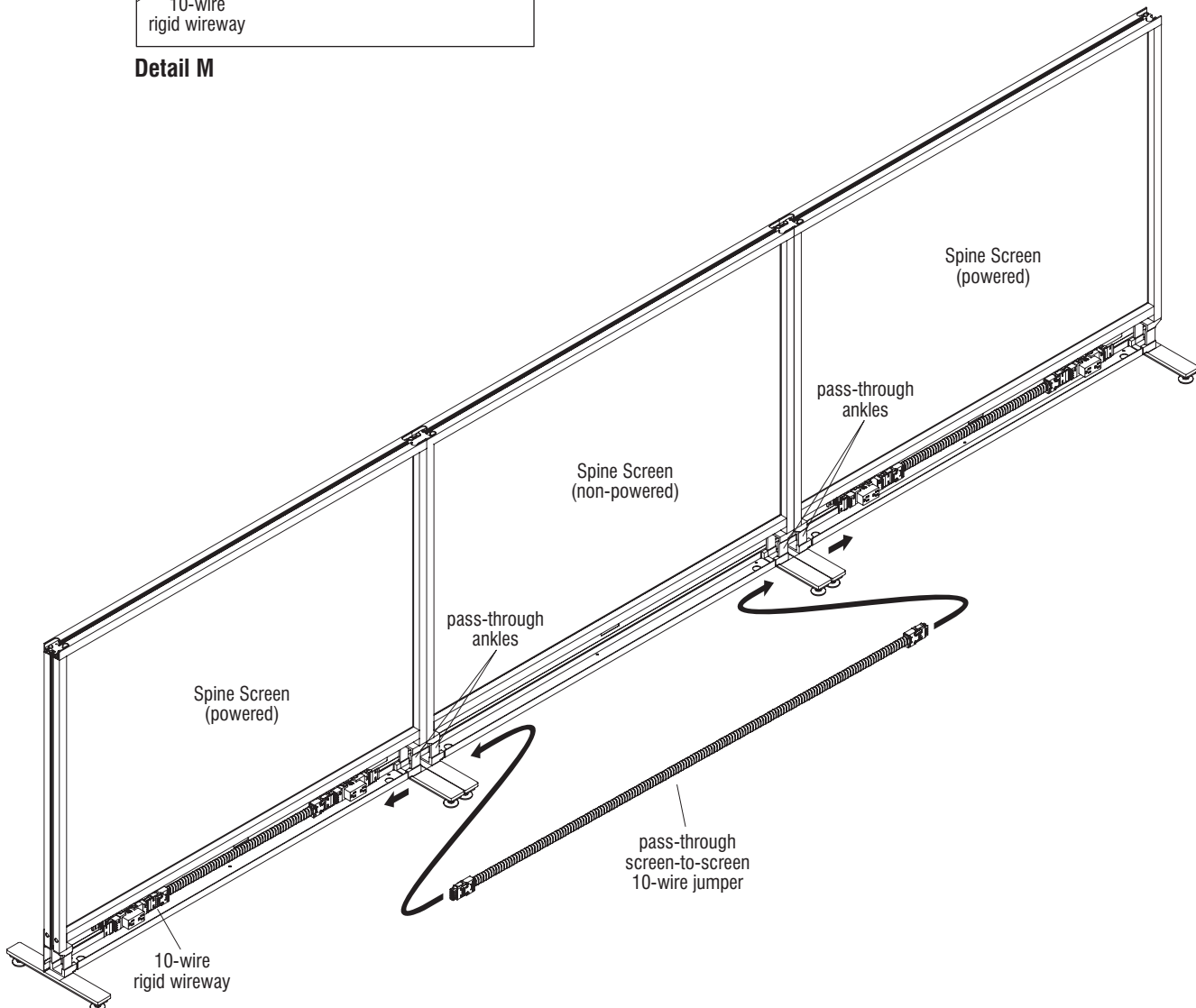

Figure 7

Tattoo™ Screens - Spine Screen 10-Wire Power

Assembly Instructions



Assemble units as described herein only. To do otherwise may result in instability. All screws, nuts and bolts must be tightened securely and must be checked periodically after assembly. Failure to assemble properly, or to secure parts may result in assembly failure and personal injury.

10-Wire Top Power Infeed (End-of-Run) Installation

Note: If the Spine Screen System is to be installed with New York City electrical, reference the Tattoo Screen System - New York City Electrical Assembly Instructions (KI-AI-000045), and proceed to the "New York City Infeed Electrical Box" instructions on page 4.

Note: The power infeeds are to be connected to the power source by a qualified electrician who must follow all state and local codes at the building site and check the electrical integrity of the finished system.

Note: All screens must be mechanically connected together, with all 10-wire rigid wireways and screen-to-screen power connections appropriately installed before adding power infeed, or connecting infeed to power source.

1. Per the space-planning layout, determine the location for top power infeed. Make sure the screen to receive top power infeed is at its final location, and is plumb and level.
2. At the ceiling, directly above the location where the end-of-run top infeed power pole will connect to the Spine Screen end, drop a plumb line from the ceiling, down to one top, end corner of the Spine Screen, then mark that location at the ceiling. At the mark on the ceiling, carefully mark and cut a rectangular hole through the ceiling at $3\frac{3}{8} \times 3$ ", as illustrated for the power pole to go through at a later step (Figure 8).
3. Measure from the ceiling, down to the floor at the end of the Spine Screen, then add 4" to that measurement for required power pole length. Take the top infeed power pole in hand and transfer that measurement to the top of the pole, then squarely cut the top of the power pole off to that measurement (Figure 8).

Note: If a power pole extension is needed for the top infeed power pole to reach the ceiling, it must be installed before installing the screen connectors. Reference "Power Pole Extension Installation" instructions on page 19, then return to step 4 on this page.

4. The screen connector comes with eight molding clips installed (shown uninstalled, Figure 8), four on each side. Position the screen connector up against the vertical frame channel of the Spine Screen, with clips oriented as shown. Using a firm hand, press at the molding clips, on the screen connector one at a time to seat them into the vertical frame channel at the end of the Spine Screen (Figure 8 & Detail N).
5. Position the end-of-run top infeed power pole, with the side opening to the desired side of the screen, and orient the top, cut end facing upward. Route the top of the power pole carefully up through the cut-out in the ceiling while pressing the side toward the screen connector/clips in the vertical frame channel of the screen. Let the bottom of the power pole rest on the ground, then press forcefully from inside the power pole at the side, to engage all molding clips of the screen connector into the vertical channel of the top infeed power pole (Figure 8 & Detail N).

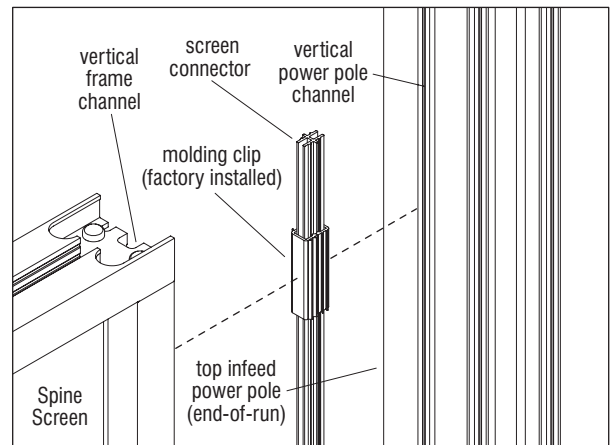

Detail N

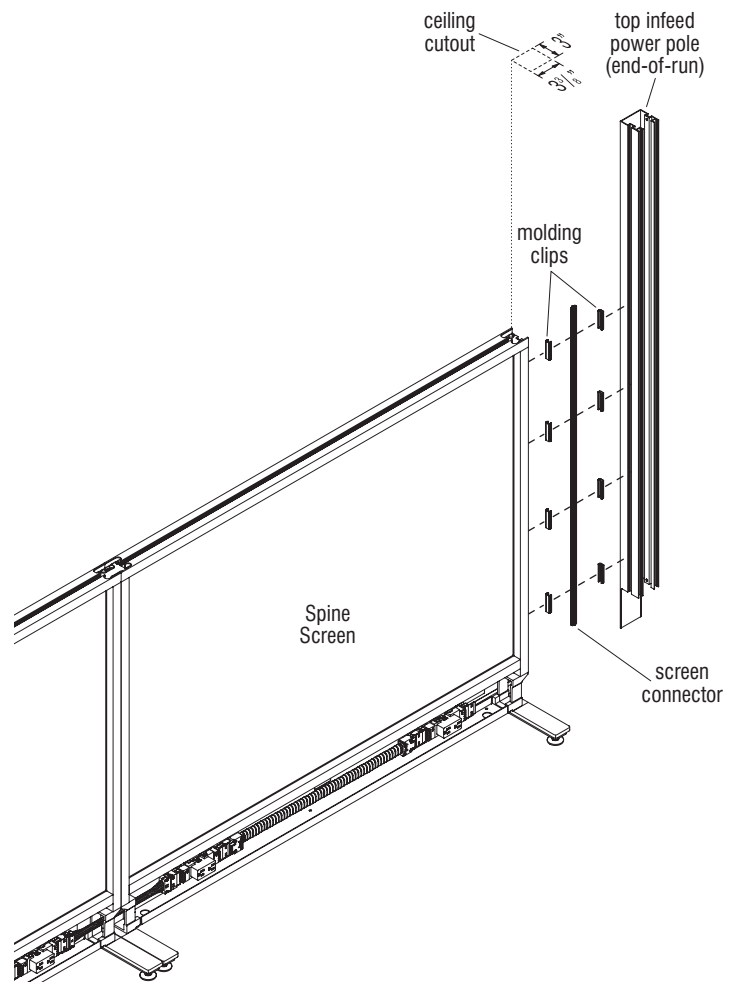
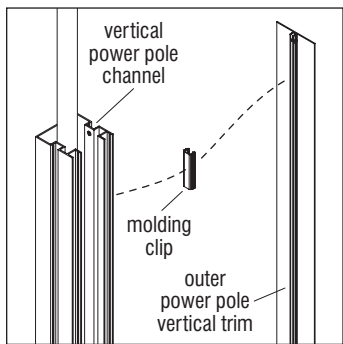

Figure 8



Assemble units as described herein only. To do otherwise may result in instability. All screws, nuts and bolts must be tightened securely and must be checked periodically after assembly. Failure to assemble properly, or to secure parts may result in assembly failure and personal injury.



Detail O

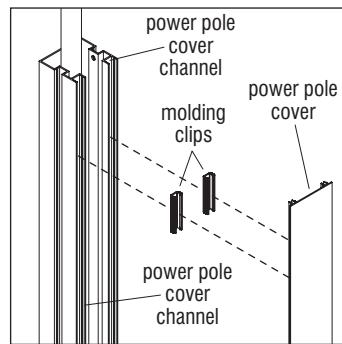

Detail P

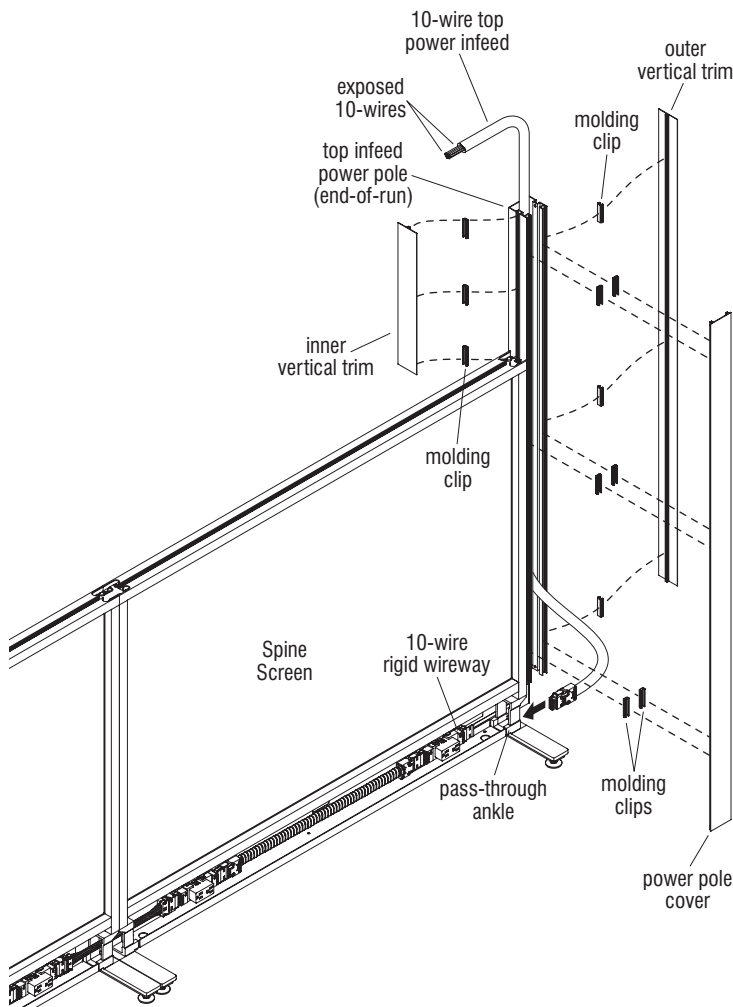

Figure 9

6. Determine the length of the inner vertical trim by measuring the distance from the ceiling to the top of the Spine Screen frame. Next, determine the length of the outer vertical trim by measuring from the ceiling, down to the floor at the outer trim location. Then, squarely cut the inner and outer vertical trim section to the measured lengths above (Figure 9).
7. On the rib side of the inner and outer vertical trim, space molding clips evenly apart and press them onto the ribs of the vertical trim as illustrated (Figure 9 & Detail O).
8. Position the inner and outer vertical trim with molding clips up against the appropriate side of the top infeed power pole channel. Using a firm hand, press the trim at the molding clip locations to snap into the power pole channel (Figure 9 & Detail O).
9. Place the 10-wire top infeed conduit inside the power pole and route the plug end of the infeed down through the pass-through ankle and plug it into the end of the 10-wire rigid wireway (Figure 9).
10. Push the 10-wire end of the power infeed up through the top of the power pole and into the above-ceiling area for later connection to the source power (by a certified electrician) (Figure 9).
11. Determine the length of the top infeed power pole cover by measuring the distance from the ceiling to the floor at the side of the infeed power pole. Cut the cover square to the marked length (Figure 9).
12. On the rib side of the power pole cover, space molding clips evenly apart and press them onto both ribs on the cover as illustrated (Figure 9 & Detail P).
13. Position the power pole cover with molding clips up against the opening side of the end-of-run top infeed power pole. Using a firm hand, press the cover at the molding clip locations to snap into power pole cover channel (Figure 9 & Detail P).

Tattoo™ Screens - Spine Screen 10-Wire Power

Assembly Instructions



Assemble units as described herein only. To do otherwise may result in instability. All screws, nuts and bolts must be tightened securely and must be checked periodically after assembly. Failure to assemble properly, or to secure parts may result in assembly failure and personal injury.

10-Wire Top Power Infeed (In-Line) Installation

Note: All screens must be mechanically connected together, with all 10-wire rigid wireways and screen-to-screen power connections appropriately installed before adding power infeed, or connecting infeed to power source.

Note: The power infeeds are to be connected to the power source by a qualified electrician who must follow all state and local codes at the building site and check the electrical integrity of the finished system.

1. Per the space-planning layout, determine the location for top power infeed. Make sure that the screens to receive top power infeed are near their final location, and are plumb and level.
2. At the ceiling, directly above the location where the in-line top infeed power pole will connect between two Spine Screen ends, drop a plumb line from the ceiling, down to one top, end corner of the Spine Screen, then mark that location at the ceiling. At the mark on the ceiling, carefully mark and cut a rectangular hole through the ceiling at $3\frac{3}{8} \times 3$ ", as illustrated for the power pole to go through at a later step (Figure 10).
3. Measure from the ceiling, down to the floor at the end of the Spine Screen, then add 4" to that measurement for required power pole length. Take the top infeed power pole in hand and transfer that measurement to the top of the power pole, then squarely cut the top of the power pole off to that measurement (Figure 10).

Note: If a power pole extension is needed for the top infeed power pole to reach the ceiling, it must be installed before installing the screen connectors. Reference "Power Pole Extension Installation" instructions on page 19, then return to step 4 on this page.

4. The two required screen connectors come with eight molding clips installed (shown uninstalled, Figure 10), four on each side. At each Spine Screen end, as illustrated, position the screen connector up against the vertical frame channel of the Spine Screen, with clips oriented as shown. Using a firm hand, press at the molding clips, on the screen connector one at a time to seat them into the vertical frame channel at the end of the Spine Screen (Figure 10 & Detail Q).
5. Position the in-line top infeed power pole, with the side opening to the desired side of the screen, and orient the top, cut end facing upward. Route the top of the power pole carefully up through the cut-out in the ceiling while pressing the side toward the screen connector/clips in the vertical frame channel of Spine Screen #1. Let the bottom of the power pole rest on the ground, then press forcefully from inside the power pole, to engage the screen connector/clips of Spine Screen #1 into the channel of the top infeed power pole. Next, move the Spine Screen #2 over to align its installed screen connector/clips with the appropriate power pole channel. Level and plumb Spine Screen #2 to #1 by twisting the height-adjustable glides clockwise or counter-clockwise until the frame's vertical edges are aligned and tops of screens are at the same height. Press Spine Screen #2 screen connector/clips into the power pole channel to engage such that both Spine Screens are snapped into the in-line top infeed power pole (Figure 10 & Detail Q).

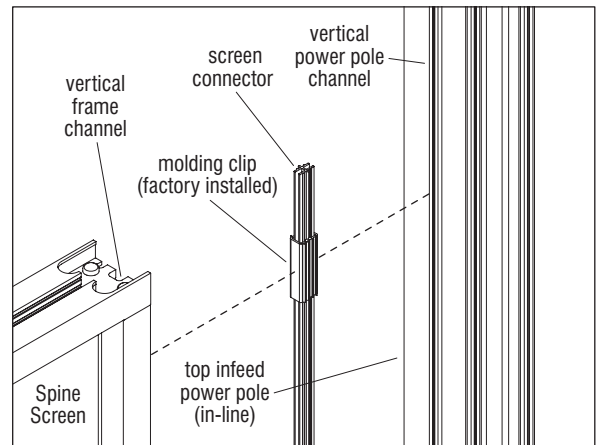

Detail Q

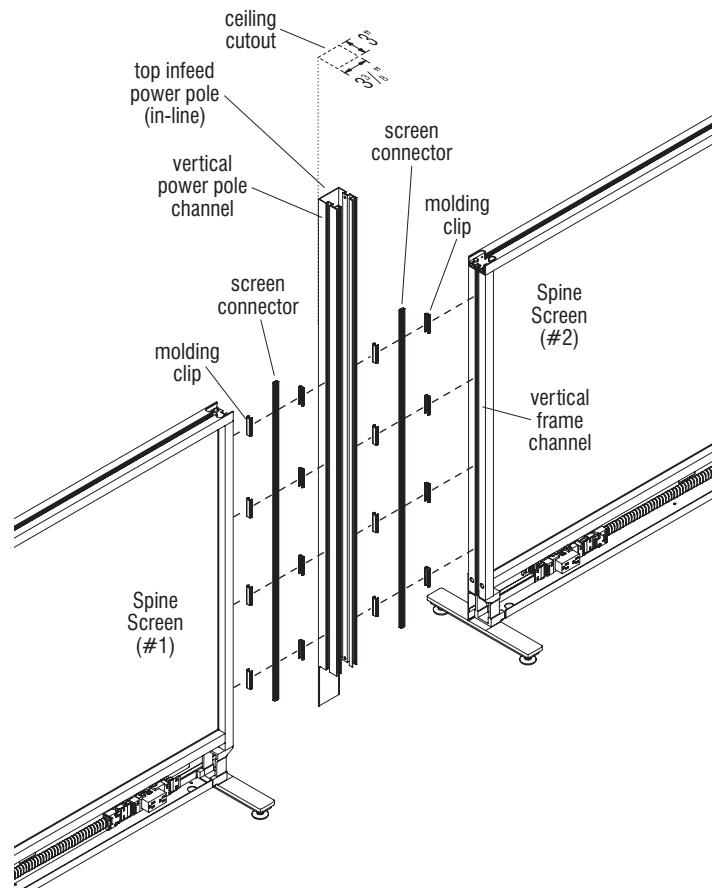
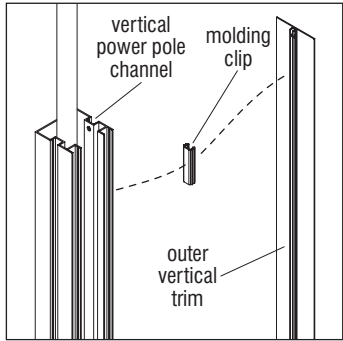

Figure 10



Assemble units as described herein only. To do otherwise may result in instability. All screws, nuts and bolts must be tightened securely and must be checked periodically after assembly. Failure to assemble properly, or to secure parts may result in assembly failure and personal injury.



Detail R

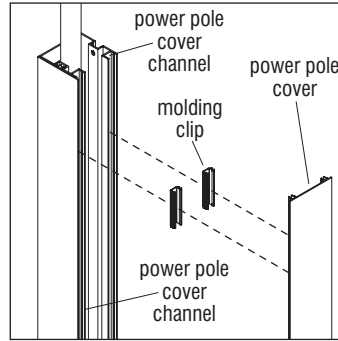

Detail S

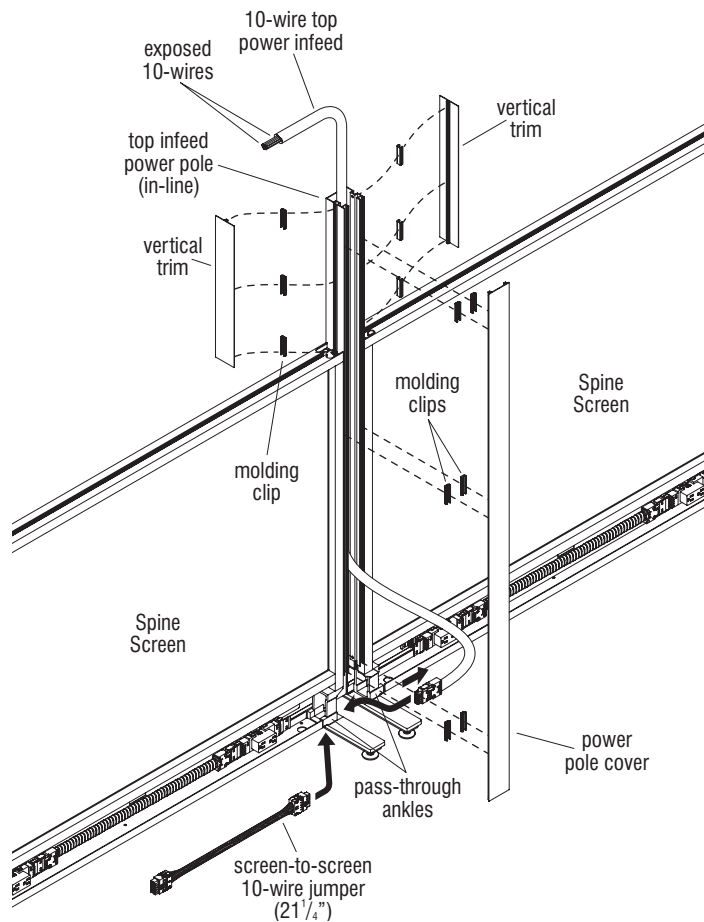

Figure 11

6. Determine the length of both vertical trim by measuring the distance from the ceiling to the top of the Spine Screen frame. Cut the vertical trim to the marked lengths (Figure 11).
7. On the rib side of the vertical trim, space molding clips evenly apart and press them onto the ribs of the vertical trim as illustrated (Figure 11 & Detail R).
8. Place the 10-wire top infeed conduit inside the power pole and route the plug end of the infeed down through the pass-through ankle and plug it into the end of the 10-wire rigid wireway (Figure 11).
9. Push the 10-wire end of the power infeed up and through the top of the power pole and into the above-ceiling area for later connection to the source power (by a certified electrician)(Figure 11).
10. Determine the length of the top infeed power pole cover by measuring the distance from the ceiling to the floor at the side of the infeed power pole. Cut the cover square to the marked length (Figure 11).
11. On the rib side of the power pole cover, space molding clips evenly apart and press them onto both ribs on the cover (Figure 11 & Detail S).
12. Position the power pole cover with molding clips up against the opening side of the end-of-run top infeed power pole. Using a firm hand, press on the trim at the molding clip locations to snap into the power pole cover channel (Figure 11 & Detail S).
13. Reference "Leveling and Connecting Spine Screens" instructions on page 6 to connect remaining screens.

Tattoo™ Screens - Spine Screen 10-Wire Power

Assembly Instructions



Assemble units as described herein only. To do otherwise may result in instability. All screws, nuts and bolts must be tightened securely and must be checked periodically after assembly. Failure to assemble properly, or to secure parts may result in assembly failure and personal injury.

10-Wire Top Power Infeed (In-Line) Installation with Flex Screen Intersection

Note: All screens must be mechanically connected together, with all 10-wire rigid wireways and screen-to-screen power connections appropriately installed before adding power infeed, or connecting infeed to power source.

Note: The power infeeds are to be connected to the power source by a qualified electrician who must follow all state and local codes at the building site and check the electrical integrity of the finished system.

1. Per the space-planning layout, determine the location for top power infeed. Make sure that the screens to receive top power infeed are near their final location, and are plumb and level.
2. At the ceiling, directly above the location where the in-line top infeed power pole will connect between two Spine Screen ends, drop a plumb line from the ceiling, down to one top, end corner of the Spine Screen, then mark that location at the ceiling. At the mark on the ceiling, carefully mark and cut a rectangular hole through the ceiling at $3\frac{3}{8} \times 3$ ", as illustrated for the power pole to go through at a later step (Figure 12).
3. Measure from the ceiling, down to the floor at the end of the Spine Screen, then add 4" to that measurement for required power pole length. Take the top infeed power pole in hand and transfer that measurement to the top of the power pole, then squarely cut the top of the power pole off to that measurement (Figure 12).

Note: If a power pole extension is needed for the top infeed power pole to reach the ceiling, it must be installed before installing the screen connectors. Reference "Power Pole Extension Installation" instructions on page 19, then return to step 4 on this page.

4. The two required screen connectors come with eight molding clips installed (shown uninstalled, Figure 12), four on each side. At Spine Screen #1's end, as illustrated, position the screen connector up against the vertical frame channel of Spine Screen #1, with clips oriented as shown. Using a firm hand, press at the molding clips, on the screen connector one at a time to seat them into the vertical frame channel at the end of Spine Screen #1 (Figure 12 & Detail T).
5. Position the in-line top infeed power pole as illustrated with the bottom backside "tongue" facing at the end of the adjoining Flex Screen to install, and orient the top, cut end facing upward. Route the top of the power pole carefully up through the cut-out in the ceiling while pressing the side toward the screen connector/clips in the vertical frame channel of Spine Screen #1. Let the bottom of the power pole rest on the ground, then press forcefully from inside the power pole, to engage the screen connector/clips of Spine Screen #1 into the channel of the top infeed power pole.
6. Carefully lift and arrange the Flex Screen foot under the perpendicular Spine Screen foot, aligning the Flex Screen against the top infeed power pole backside during the process (Figure 12).

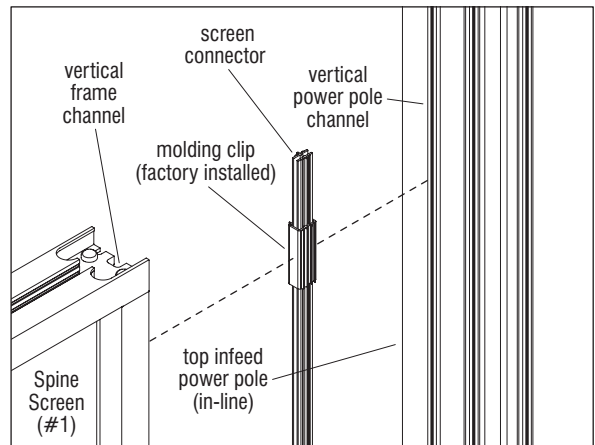

Detail T

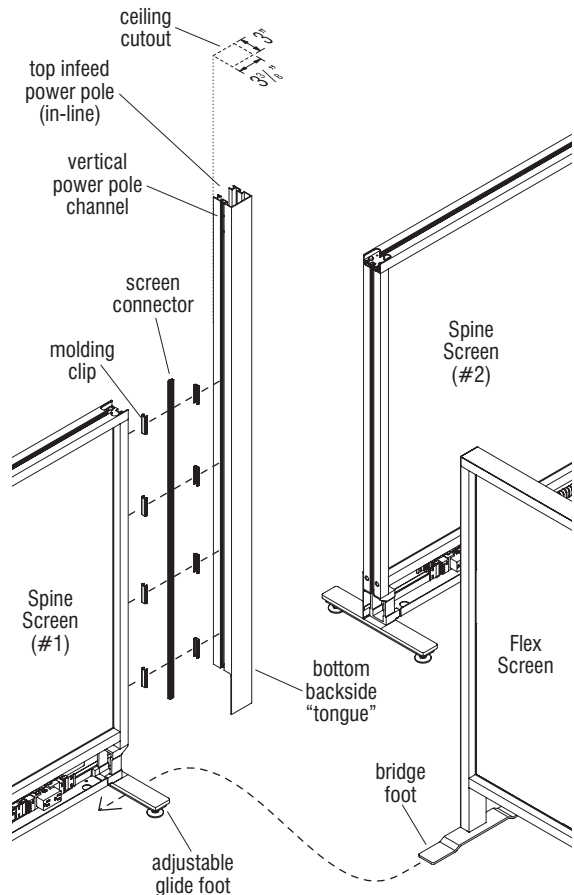
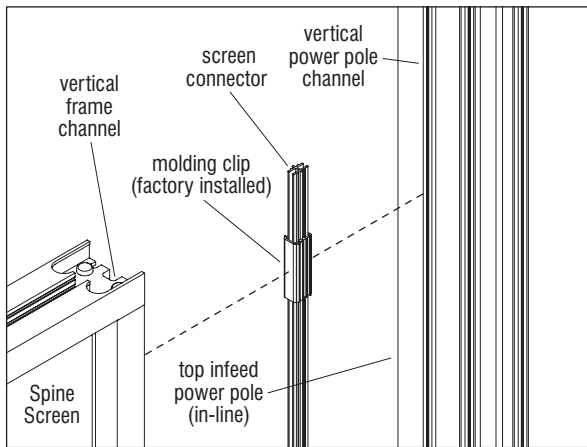

Figure 12



Assemble units as described herein only. To do otherwise may result in instability. All screws, nuts and bolts must be tightened securely and must be checked periodically after assembly. Failure to assemble properly, or to secure parts may result in assembly failure and personal injury.



Detail V

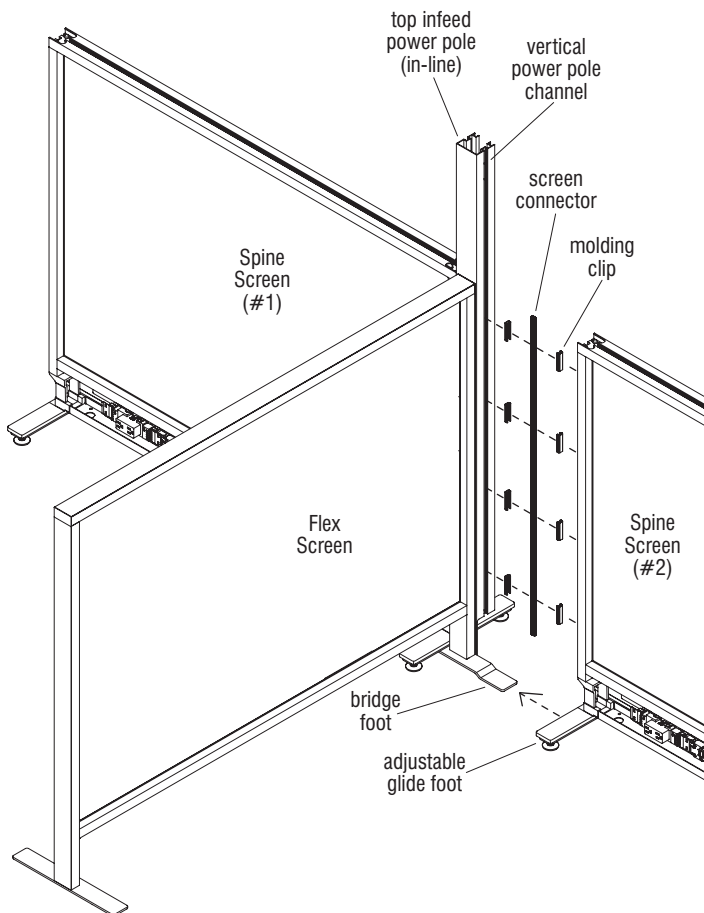
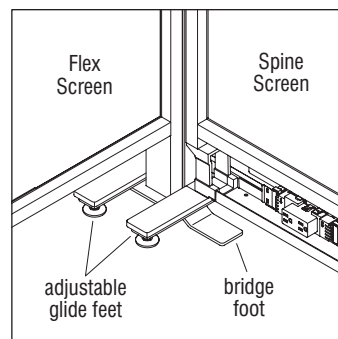

Figure 13



Detail U - Spine Screen 3-Way Intersection with Flex Screen (adjustable feet over bridge foot)

Note: All screens must be mechanically connected together, with all 10-wire rigid wireways and screen-to-screen power connections appropriately installed before adding power infeed, or connecting infeed to power source.

Note: The power infeeds are to be connected to the power source by a qualified electrician who must follow all state and local codes at the building site and check the electrical integrity of the finished system.

7. Carefully lift and arrange Spine Screen #2 so that the adjustable foot is over the foot of the Flex Screen (Detail U). Move Spine Screen #2 over to align its installed screen connector/clips with the appropriate power pole channel. Level and plumb Spine Screen #2 to #1 by twisting the height-adjustable glides clockwise or counter-clockwise until the frame's vertical edges are aligned and tops of screens are at the same height. Press Spine Screen #2 screen connector/clips into the power pole channel to engage such that both Spine Screens are snapped into the in-line top infeed power pole (Figure 13 & Detail V).

Tattoo™ Screens - Spine Screen 10-Wire Power

Assembly Instructions



Assemble units as described herein only. To do otherwise may result in instability. All screws, nuts and bolts must be tightened securely and must be checked periodically after assembly. Failure to assemble properly, or to secure parts may result in assembly failure and personal injury.

10-Wire Top Power Infeed (In-Line) Installation with Flex Screen Intersection (cont.)

Note: Each powered Spine Screen has two 10-wire rigid wireways that are pre-mounted in the base raceway at the factory.

Note: Spine Screen electrical is "in-line" only and does not turn corners. Spine Screens cannot pass power to Flex Screens.

8. Determine the length of both vertical trim by measuring the distance from the ceiling to the top of the Spine Screen frame. Cut the vertical trim to the marked lengths (Figure 14).
9. On the rib side of the vertical trim, space molding clips evenly apart and press them onto the ribs of the vertical trim as illustrated (Figure 14 & Detail W).
10. Place the 10-wire top infeed conduit inside the power pole and route the plug end of the infeed down through the pass-through ankle and plug it into the end of the 10-wire rigid wireway (Figure 14).
11. Push the 10-wire end of the power infeed up and through the top of the power pole and into the above-ceiling area for later connection to the source power (by a certified electrician)(Figure 14).
12. Determine the length of the top infeed power pole cover by measuring the distance from the ceiling to the floor at the side of the infeed power pole. Cut the cover square to the marked length (Figure 14).
13. On the rib side of the power pole cover, space molding clips evenly apart and press them onto both ribs on the cover (Figure 14 & Detail X).

14. Position the power pole cover with molding clips up against the opening side of the end-of-run top infeed power pole. Using a firm hand, press on the trim at the molding clip locations to snap into the power pole cover channel (Figure 14 & Detail X).
15. Reference "Leveling and Connecting Spine Screens" instructions on page 6 to connect remaining screens.

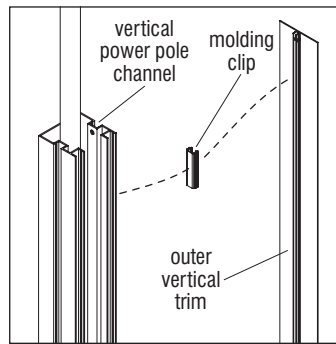

Detail W

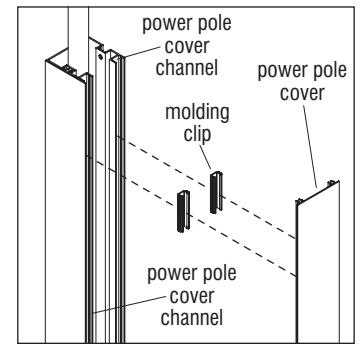

Detail X

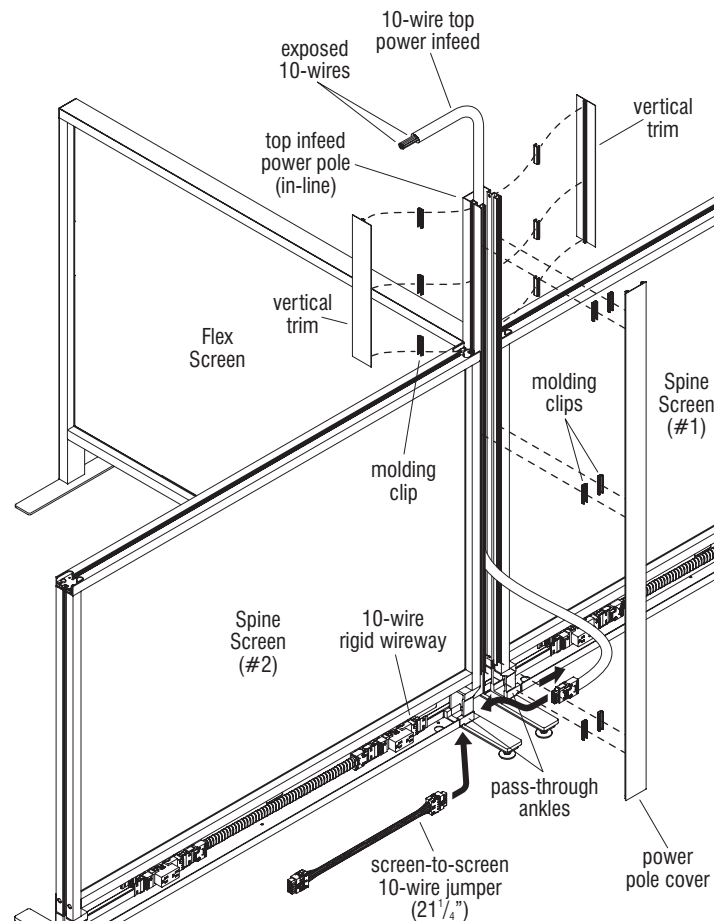

Figure 14



Assemble units as described herein only. To do otherwise may result in instability. All screws, nuts and bolts must be tightened securely and must be checked periodically after assembly. Failure to assemble properly, or to secure parts may result in assembly failure and personal injury.

Power Pole Extension Installation

Note: The power pole extension is specified for ceilings higher than 10', and must be added to the top infeed power pole prior to installing the pole to the Spine Screen(s). The Spine Screen(s) to receive the power pole with extension must be at their final installation location.

1. Assure that the Spine Screen(s) to receive the power pole with extension are at their final installation location, the hole is cut in the ceiling as

specified earlier (pages 12, 14 & 16), then measure from the ceiling to the floor at the end of a screen which will receive the extended pole. The top infeed power pole is 122" long, so subtract 122" from the floor to ceiling measurement, then add 4" for the length to cut the extension pole to. Take the power pole extension in hand, transfer the required length measurement to it and squarely cut the extension pole to size such that it can project 4" above ceiling height when installed.

2. As illustrated, align the open side of the power pole extension bracket with the open side at the top of the top infeed power pole, and slide the extension bracket into the power pole, aligning the mounting holes of both. Insert four #10-24 x 1/2" Phillips flat head screws through the power pole and bracket at four mounting locations, then add #10-24 lock nuts and tighten (Figure 15 & Detail Y).
3. Orient the cut-off end of the pole extension away from the power pole's installed extension bracket. With the opened side of the power pole extension facing in the same direction as the installed power pole extension bracket opening, slide the extension pole onto the power pole extension bracket, aligning the mounting holes of both (Figure 16 & Detail Z).
4. Insert four #10-24 x 1/2" Phillips flat head screws through the power pole extension and bracket at four mounting locations, then add #10-24 lock nuts and tighten (Figure 16 & Detail Z).

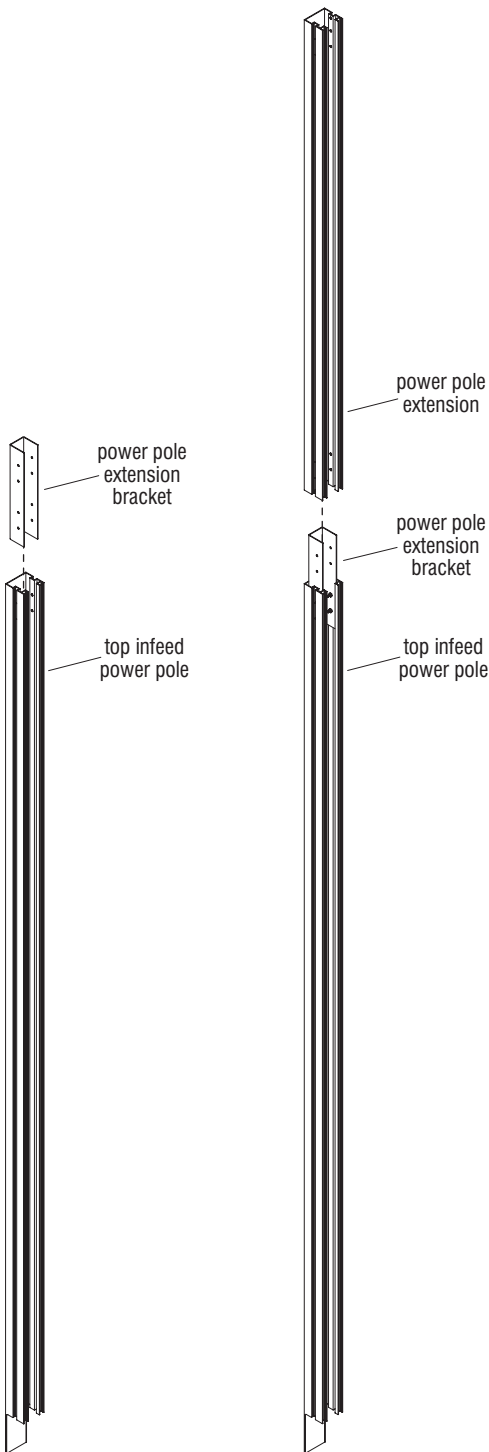
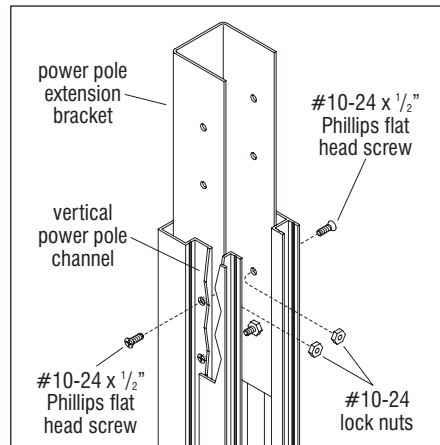
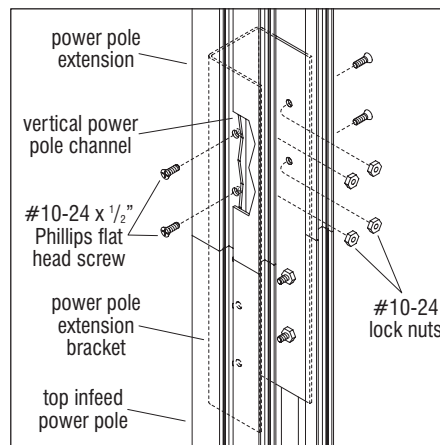

Figure 15

Figure 16



Detail Y



Detail Z

Reference "10-Wire Top Power Infeed (End-of-Run) Installation" instructions on page 12, step 4, "10-Wire Top Power Infeed (In-Line) Installation" instructions on page 14, step 4, or "10-Wire Top Power Infeed (In-Line) Installation with Flex Screen Intersection" instructions on page 16, step 4 to finish top infeed power pole installation.

Tattoo™ Screens - Spine Screen 10-Wire Power

Assembly Instructions



Assemble units as described herein only. To do otherwise may result in instability. All screws, nuts and bolts must be tightened securely and must be checked periodically after assembly. Failure to assemble properly, or to secure parts may result in assembly failure and personal injury.

10-Wire Base Power Infeed (End-of-Run) Installation

Important: If the Spine Screen System is to be installed with New York City electrical, reference the Tattoo Screen System - New York City Electrical Assembly Instructions (KI-AI-000045), and proceed to the "New York City Infeed Electrical Box" instructions on page 4.

Note: The power infeeds are to be connected to the power source by a qualified electrician who must follow all state and local codes at the building site and check the electrical integrity of the finished system.

Note: All screens must be mechanically connected together, with all 10-wire rigid wireways and screen-to-screen power connections appropriately installed before adding power infeed, or connecting infeed to power source.

1. Per the space-planning layout, determine the location for base power infeed. Make sure that screen to receive base power infeed is in its final location, and is plumb and level.
2. At the bottom of the screen frame which will receive base power infeed, route the plug end of the 10-wire base infeed conduit through the pass-through ankle and plug it into the end of the 10-wire rigid wireway (Figure 17).
3. On the rib side of the end-of-run base infeed trim, space molding clips evenly apart and press them onto the ribs of the trim as illustrated (Figure 18).
4. Position the end-of-run base infeed trim with molding clips up against the vertical frame channel. Align the top of the trim with the bottom of the horizontal frame and position the 10-wire base infeed through the U-shaped cutout. Using a firm hand, press to snap molding clips of the end-of-run base infeed trim into the vertical frame channel (Figure 18).

5. Place the end-of-run corner cap into the notch formed on the top corner of the horizontal frame. Align the mounting holes on the horizontal frame with the mounting holes on the corner cap and secure with two #10-24 x 3/8" Torx screws (Figure 18).

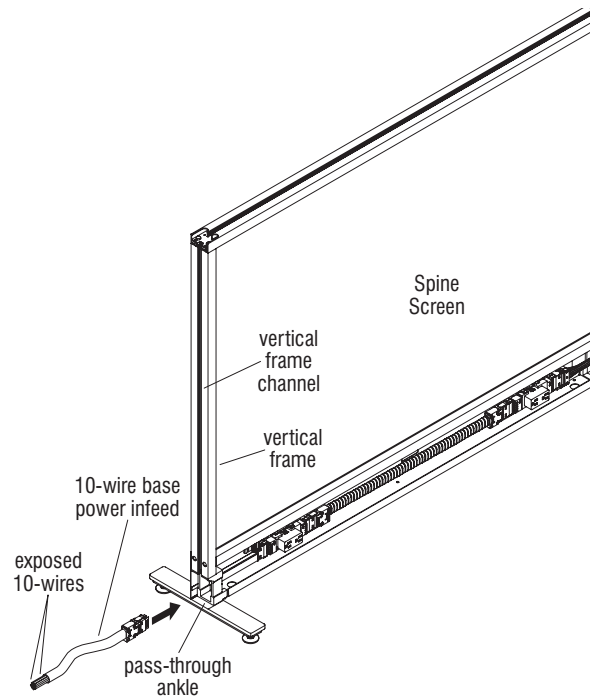

Figure 17

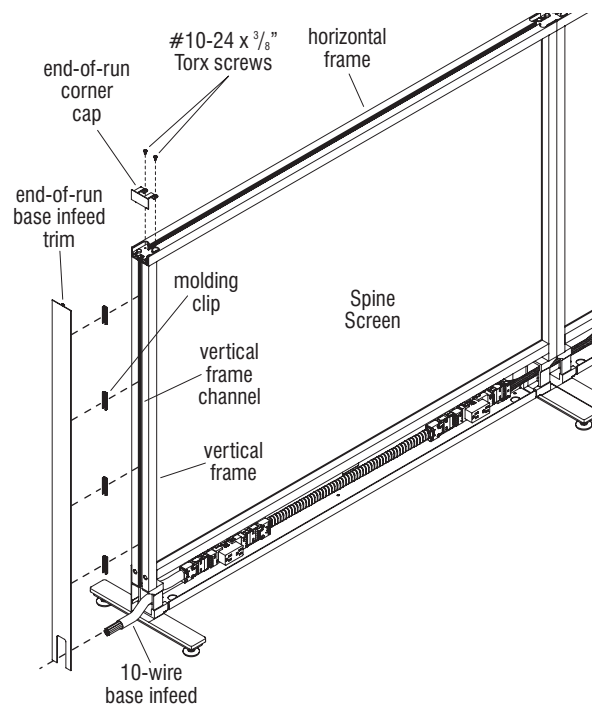
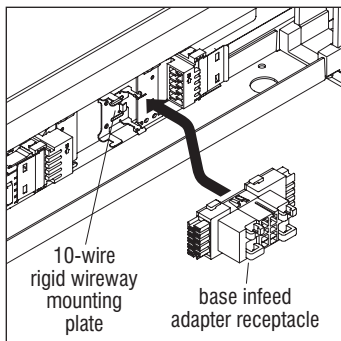

Figure 18



Assemble units as described herein only. To do otherwise may result in instability. All screws, nuts and bolts must be tightened securely and must be checked periodically after assembly. Failure to assemble properly, or to secure parts may result in assembly failure and personal injury.



Detail AA

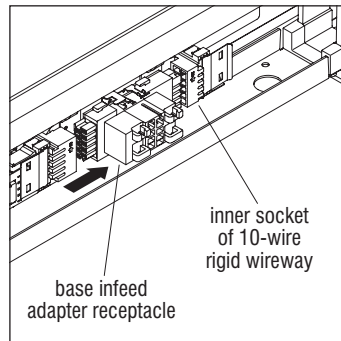

Detail BB

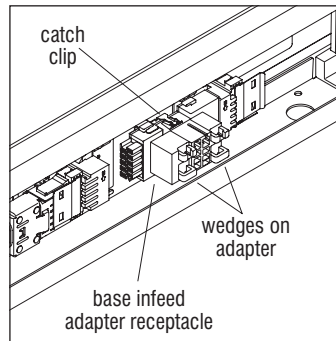

Detail CC

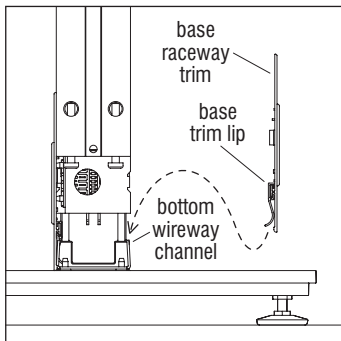

Detail DD

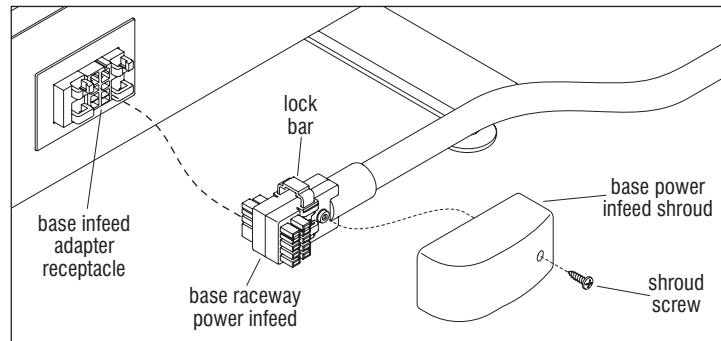

Detail EE

Base Raceway Power Infeed Installation

1. Position the base infeed adapter receptacle on the end of the 10-wire rigid wireway where the base power infeed is received, matching the arrow at the "N" symbol facing up (Figure 19 & Detail AA).
2. Align the adapter so the end is in-line with the inner socket on the rigid wireway and push the adapter back against the mounting plate (Detail AA).
3. Slide the adapter receptacle to the side and snap it into the rigid wireway's inner socket (Detail BB).
4. Adapter is properly seated when the catch clip on the wireway is snapped in between the wedges on the receptacle (Detail CC).
5. Install the base raceway trim by engaging the base trim lip with the bottom wireway channel (Detail DD).
6. Pull up the lock bar on the plug end of the base raceway power infeed. The base infeed can be rotated 180° and installed in one of two directions. Orient the lock bar to be up, then press the base raceway power infeed to the adapter receptacle in the desired direction. Press down to snap and secure the lock bar onto the base infeed adapter receptacle on the power infeed, then place the base infeed shroud over the infeed and secure with the shroud screw provided (Figure 20 & Detail EE).

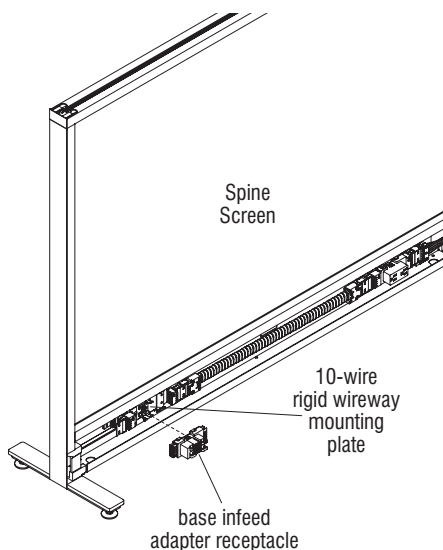

Figure 19

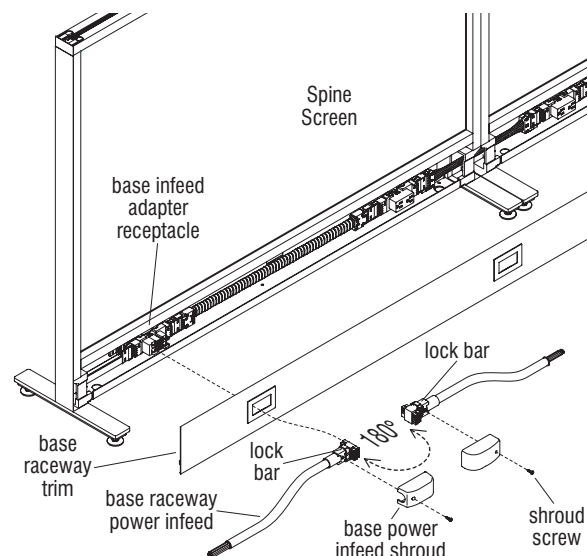

Figure 20

Tattoo™ Screens - Spine Screen 10-Wire Power

Assembly Instructions



Assemble units as described herein only. To do otherwise may result in instability. All screws, nuts and bolts must be tightened securely and must be checked periodically after assembly. Failure to assemble properly, or to secure parts may result in assembly failure and personal injury.

10-Wire Base Power Infeed Spacer (End-of-Run) Installation

Important: If the Spine Screen System is to be installed with New York City electrical, reference the Tattoo Screen System - New York City Electrical Assembly Instructions (KI-AI-000045), and proceed to the "New York City Infeed Electrical Box" instructions on page 4.

Note: The power infeeds are to be connected to the power source by a qualified electrician who must follow all state and local codes at the building site and check the electrical integrity of the finished system.

Note: All screens must be mechanically connected together, with all 10-wire rigid wireways and screen-to-screen power connections appropriately installed before adding power infeed, or connecting infeed to power source.

1. Per the space-planning layout, determine the location for base power infeed. Make sure that screen to receive base power infeed is in its final location, and is plumb and level.
2. At the bottom of the screen frame which will receive base power infeed, route the plug end of the 10-wire base infeed conduit through the pass-through ankle and plug it into the end of the 10-wire rigid wireway (Figure 21).
3. The screen connector comes with eight molding clips installed (shown uninstalled, Figure 23), four on each side. Position the screen connector up against the vertical frame channel of the Spine Screen, with clips oriented as shown. Using a firm hand, press at the mounting clips on the screen connector, one at a time to seat them into the vertical frame channel at the end of the Spine Screen (Figure 22 & Detail FF).
4. Position the base infeed spacer against the vertical frame, with the side opening as desired, and the top facing upward. If the base infeed

spacer top is higher than the top of the Spine Screen's horizontal frame, the spacer is too tall at the top and must be squarely cut off from the bottom. Cut required amount off the bottom, then press the side of the base infeed spacer with the molding clips in the vertical frame channel on the Spine Screen taking care to align the top of the base infeed spacer with the top of the screen's horizontal frame. Press forcefully from inside the spacer at the side, to engage the screen connector into the channel of the base infeed spacer (Figure 22 & Detail FF).

Note: Two different top caps are available for Tattoo Screen spacers and are labeled so on the bottom of each top cap. An "E" or "I" is displayed on each top cap to represent if the cap is for end-of-run or in-line. As labeled, the top caps are designed to install to a specific spacer. Take care and follow the directions below when installing the top cap. If proper top cap is not installed to the proper spacer, the flat aluminum top cap will not fit correctly, extending too far and disassembly and reassembly will be required.

5. Confirm the base infeed top cap is labelled "E" on the underside for end-of-run. Place the base infeed top cap onto the base infeed spacer. Align the mounting hole on the side of the top cap with the mounting

hole in the spacer cover channel and secure with a #10-24 x 1/2" Phillips flat head screw. The base infeed top cap will rest flush with the flat aluminum top cap installed in a later step (Figure 22 & Detail FF).

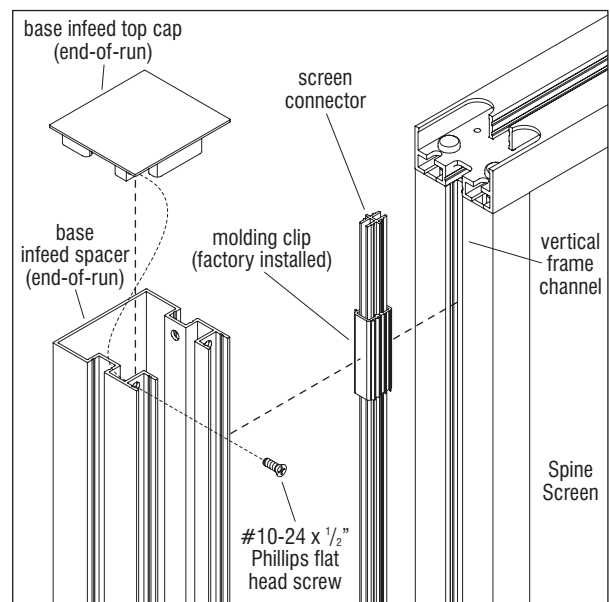

Detail FF

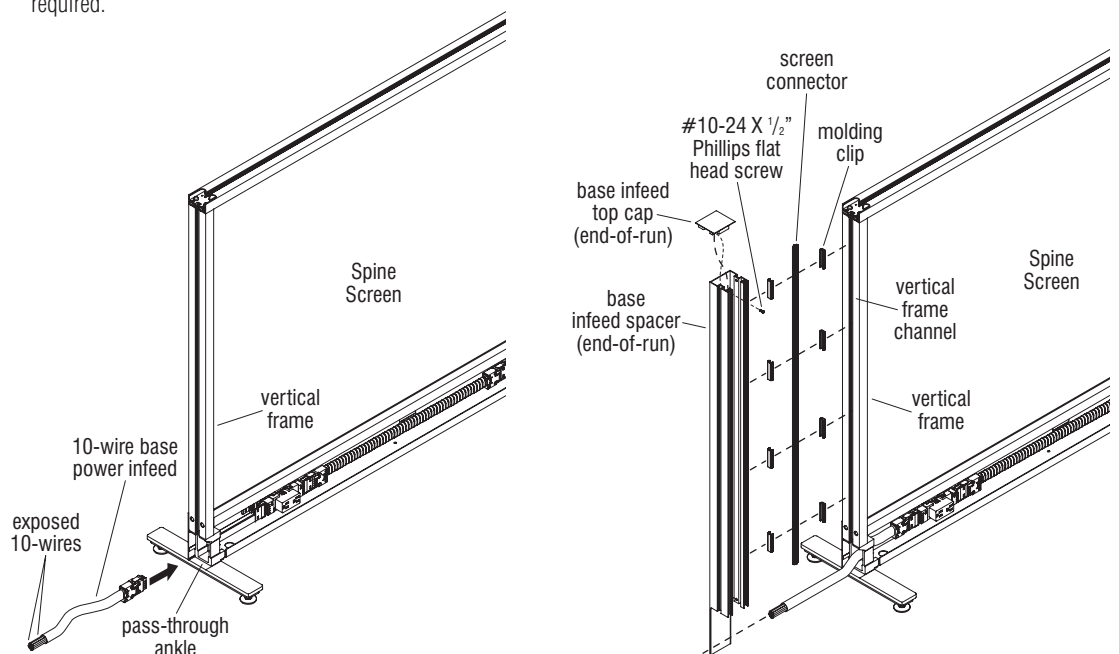
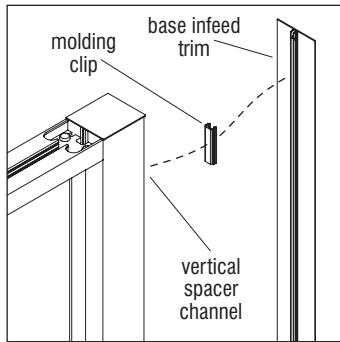

Figure 21

Figure 22



Assemble units as described herein only. To do otherwise may result in instability. All screws, nuts and bolts must be tightened securely and must be checked periodically after assembly. Failure to assemble properly, or to secure parts may result in assembly failure and personal injury.



Detail GG

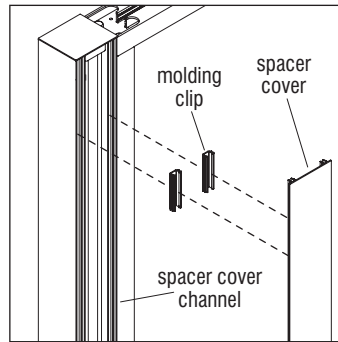

Detail HH

6. On the rib side of the base infeed trim, space molding clips evenly apart and press them onto the ribs of the trim (Figure 23 & Detail GG).
7. Position the base infeed trim with molding clips up against the base infeed spacer with the 10-wire infeed routed through the opening at the bottom of the infeed trim. Using a firm hand, press to snap molding clips of the base infeed trim into the vertical spacer channel (Figure 23 & Detail GG).
8. On the rib side of the base infeed spacer cover, space molding clips evenly apart and press them onto both ribs on the cover (Figure 23 & Detail HH).
9. Position the base infeed spacer cover with molding clips up against the base infeed spacer. Using a firm hand, press to snap molding clips of the spacer cover into the spacer cover channel (Figure 23 & Detail HH).

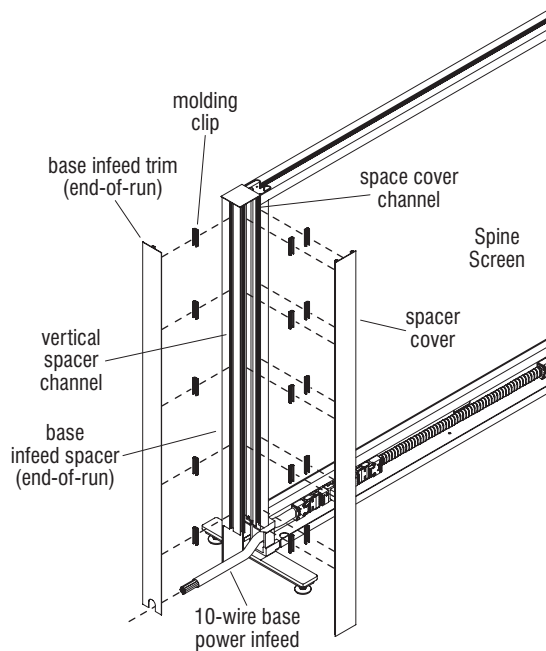

Figure 23

Tattoo™ Screens - Spine Screen 10-Wire Power

Assembly Instructions



Assemble units as described herein only. To do otherwise may result in instability. All screws, nuts and bolts must be tightened securely and must be checked periodically after assembly. Failure to assemble properly, or to secure parts may result in assembly failure and personal injury.

10-Wire Base Power Infeed Spacer (In-Line) Installation

Note: All screens must be mechanically connected together, with all 10-wire rigid wireways and screen-to-screen power connections appropriately installed before adding power infeed, or connecting infeed to power source.

Note: The power infeeds are to be connected to the power source by a qualified electrician who must follow all state and local codes at the building site and check the electrical integrity of the finished system.

1. Per the space-planning layout, determine the location for base infeed spacer. Make sure that the screens to receive the base infeed spacer are near their final location, and are plumb and level.
2. The two required screen connectors come with eight molding clips installed to each (shown uninstalled, Figure 24), four on each side. At each Spine Screen end, as illustrated, position the screen connector up against the vertical frame channel of the Spine Screen, with clips oriented as shown. Using a firm hand, press at the mounting clips on the screen connector, one at a time to seat them into the vertical frame channel at the end of the Spine Screen (Figure 24 & Detail II).
3. Position the base infeed spacer against the vertical frame, with the side opening as desired, and the top facing upward. If the base infeed spacer top is higher than the top of the Spine Screen's horizontal frame, the spacer is too tall at the top and must be squarely cut off from the bottom. Cut required amount off the bottom, then press the side of the base infeed spacer with the molding clips in the vertical frame channel on the Spine Screen taking care to align the top of the base infeed spacer with the top of the screen's horizontal frame. Press forcefully from inside the spacer, to engage the screen connector/clips of Spine Screen #1 into the channel of the base infeed

spacer. Next, move the Spine Screen #2 over to align its installed screen connector/clips with the appropriate vertical spacer channel. Level and plumb Spine Screen #2 to #1 by twisting the height-adjustable glides clockwise or counter-clockwise until the frame's vertical edges are aligned and tops of screens are at the same height. Press Spine Screen #2 into the vertical spacer channel to engage such that both Spine Screens are snapped into the base infeed spacer (Figure 24 & Detail II).

Note: Two different top caps are available for Tattoo Screen spacers and are labeled so on the bottom of each top cap. An "E" or "I" is displayed on each top cap to represent if the cap is for end-of-run or in-line. As labeled, the top caps are designed to install to a specific spacer. Take care and follow the directions below when installing the top cap. If top cap is not installed to the proper spacer, the flat aluminum top cap will not fit correctly, extending too far and disassembly and reassembly will be required.

4. Confirm the base infeed top cap is labelled "I" on the underside for inline. Place the base infeed top cap onto the base infeed spacer. Align the mounting hole on the side of the top cap with the mounting hole in the spacer cover channel and secure with a #10-24 x 1/2" Phillips flat head screw. The base infeed top cap will rest flush with the flat aluminum top cap installed in a later step (Figure 24 & Detail II).
5. At the location specified for a screen-to-screen jumper between the base infeed spacer, route the jumper through the pass-through ankles at each end of the Spine Screen, then plug the ends into each rigid wireway of the powered Spine Screens (Figure 24).
6. Route the 10-wire base power infeed plug end of the infeed through the pass-through ankle and plug it into an open end of a 10-wire rigid wireway (Figure 24).

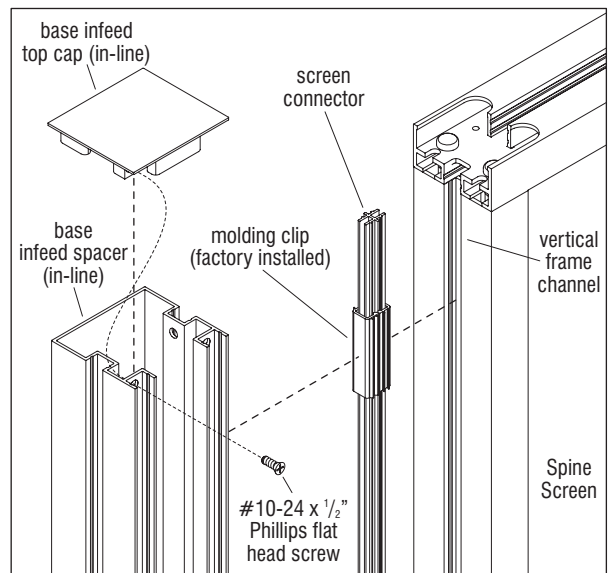

Detail II

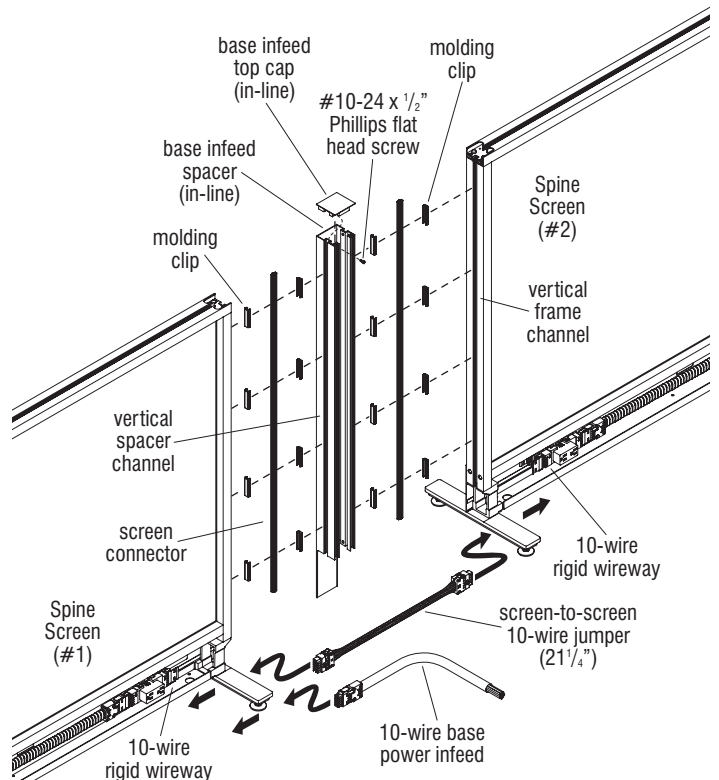
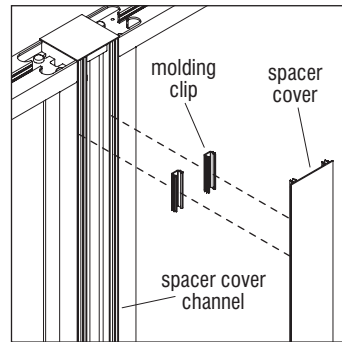

Figure 24



Assemble units as described herein only. To do otherwise may result in instability. All screws, nuts and bolts must be tightened securely and must be checked periodically after assembly. Failure to assemble properly, or to secure parts may result in assembly failure and personal injury.



Detail JJ

7. On the rib side of the spacer cover, space molding clips evenly apart and press them onto the ribs of the cover (Figure 25 & Detail JJ).
8. Position the spacer cover with molding clips up against the spacer cover channel with the 10-wire base infeed routed through the opening at the bottom of the spacer cover. Using a firm hand, press on the spacer cover at the molding clip locations to snap molding clips into the spacer cover channel (Figure 25 & Detail JJ).
9. Reference "Leveling and Connecting Spine Screens" instructions on page 6 to connect remaining screens.

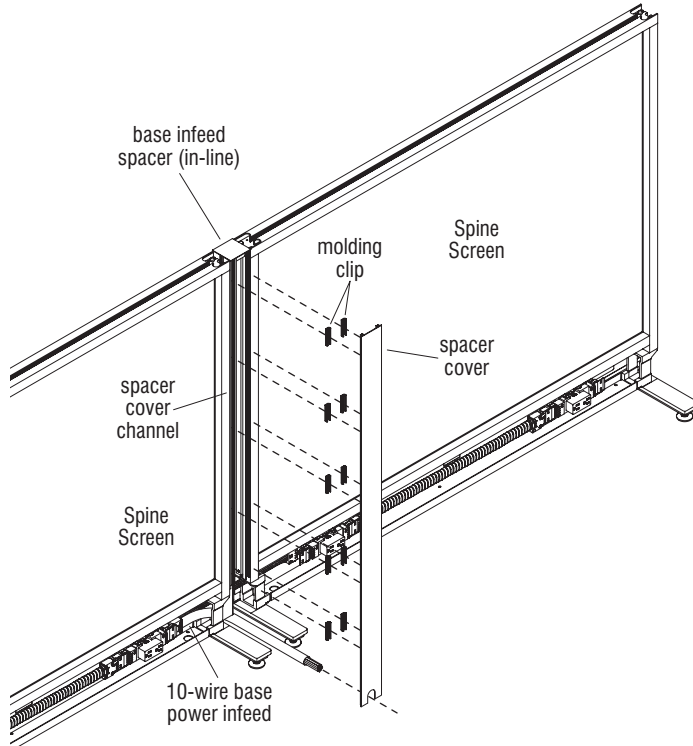

Figure 25

Tattoo™ Screens - Spine Screen 10-Wire Power

Assembly Instructions



Assemble units as described herein only. To do otherwise may result in instability. All screws, nuts and bolts must be tightened securely and must be checked periodically after assembly. Failure to assemble properly, or to secure parts may result in assembly failure and personal injury.

10-Wire Base Power Infeed Spacer (In-Line) Installation with Flex Screen Intersection

Note: All screens must be mechanically connected together, with all 10-wire rigid wireways and screen-to-screen power connections appropriately installed before adding power infeed, or connecting infeed to power source.

Note: The power infeeds are to be connected to the power source by a qualified electrician who must follow all state and local codes at the building site and check the electrical integrity of the finished system.

1. Per the space-planning layout, determine the location for base infeed spacer. Make sure that the screens to receive the base infeed spacer are near their final location, and are plumb and level.
2. The two required screen connectors come with eight molding clips installed to each (shown uninstalled, Figure 26), four on each side. At Spine Screen #1's end, as illustrated, position the screen connector up against the vertical frame channel of Spine Screen #1, with clips oriented as shown. Using a firm hand, press at the mounting clips on the screen connector, one at a time to seat them into the vertical frame channel at the end of the Spine Screen #1 (Figure 26 & Detail KK).
3. Position the base infeed spacer as illustrated with the bottom backside "tongue" facing at the end of the adjoining Flex Screen to install. If the base infeed spacer top is higher than the top of the Spine Screen #1's horizontal frame, the spacer is too tall at the top and must be squarely cut off from the bottom. Cut required amount off the bottom, then press the side of the base infeed spacer with the molding clips in the vertical frame channel on Spine Screen #1 taking care to align the top of the base infeed spacer with the top of the screen's horizontal frame. Press forcefully from inside the spacer, to engage the screen connector/clips

of Spine Screen #1 into the channel of the base infeed spacer into an open end of a 10-wire rigid wireway (Figure 26).

4. Carefully lift and arrange the Flex Screen foot under the perpendicular Spine Screen foot, aligning the Flex Screen against the base infeed spacer backside during the process (Figure 26).

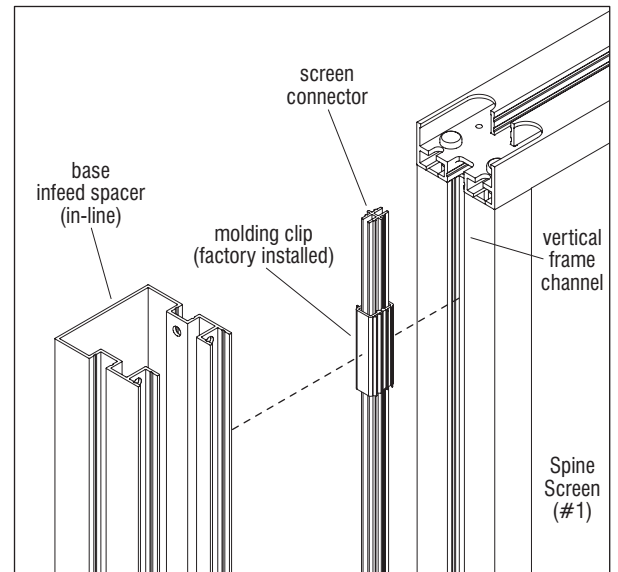

Detail KK

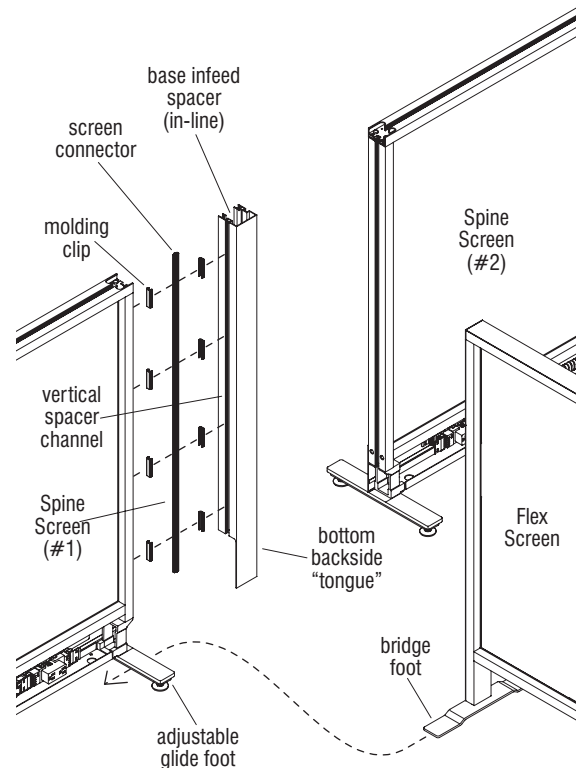
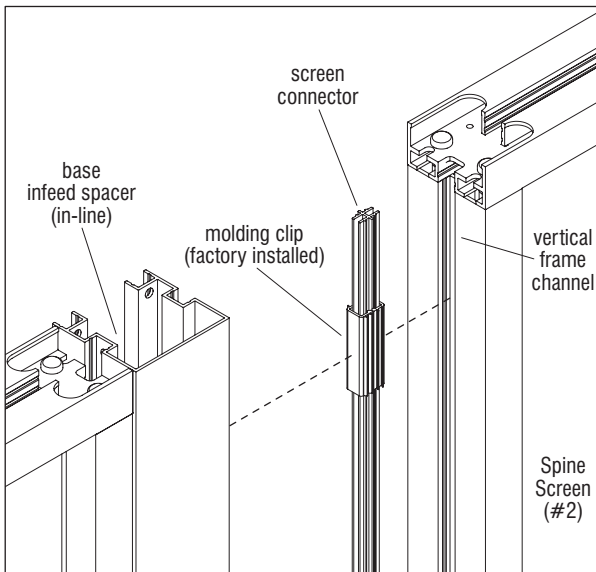

Figure 26



Assemble units as described herein only. To do otherwise may result in instability. All screws, nuts and bolts must be tightened securely and must be checked periodically after assembly. Failure to assemble properly, or to secure parts may result in assembly failure and personal injury.



Detail LL

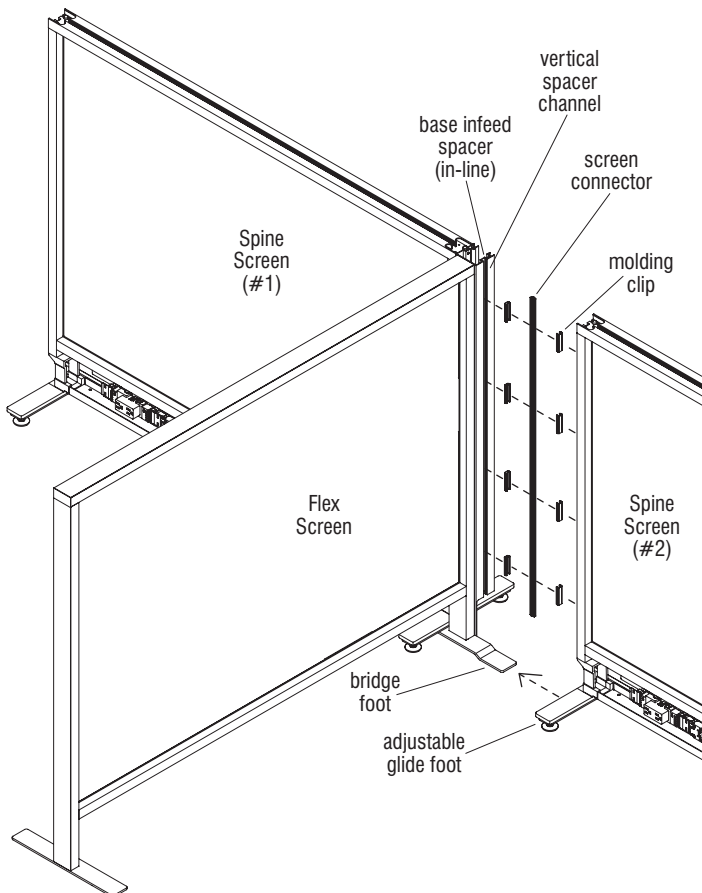
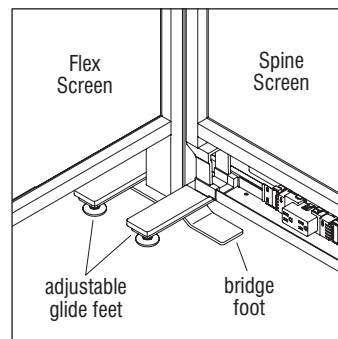

Figure 27



Detail MM - Spine Screen 3-Way Intersection with Flex Screen (adjustable feet over bridge foot)

- Carefully lift and arrange Spine Screen #2 so that the adjustable foot is over the foot of the Flex Screen (Detail MM). Move Spine Screen #2 over to align its installed screen connector/clips with the appropriate vertical spacer channel. Level and plumb Spine Screen #2 to #1 by twisting the height-adjustable glides clockwise or counter-clockwise until the frame's vertical edges are aligned and tops of screens are at the same height. Press Spine Screen #2 screen connector/clips into the vertical spacer channel to engage such that both Spine Screens are snapped into the in-line base infeed spacer (Figure 27 & Detail LL).

Tattoo™ Screens - Spine Screen 10-Wire Power
 Assembly Instructions



Assemble units as described herein only. To do otherwise may result in instability. All screws, nuts and bolts must be tightened securely and must be checked periodically after assembly. Failure to assemble properly, or to secure parts may result in assembly failure and personal injury.

10-Wire Base Power Infeed Spacer (In-Line) Installation with Flex Screen Intersection (cont.)

Note: Two different top caps are available for Tattoo Screen spacers and are labeled so on the bottom of each top cap. An “E” or “I” is displayed on each top cap to represent if the cap is for end-of-run or in-line. As labeled, the top caps are designed to install to a specific spacer. Take care and follow the directions below when installing the top cap. If proper top cap is not installed to the proper spacer, the flat aluminum top cap will not fit correctly, extending too far and disassembly and reassembly will be required.

6. Confirm the base infeed top cap is labelled “I” on the underside for in-line. Place the base infeed top cap onto the base infeed spacer. Align the mounting hole on the side of the top cap with the mounting hole in the spacer cover channel and secure with a #10-24 x 1/2” Phillips flat head screw. The base infeed top cap will rest flush with the flat aluminum top cap installed in a later step (Figure 28 & Detail NN).

Note: Each powered Spine Screen has two 10-wire rigid wireways that are pre-mounted in the base raceway at the factory.

Note: Spine Screen electrical is “in-line” only and does not turn corners. Spine Screens cannot pass power to Flex Screens.

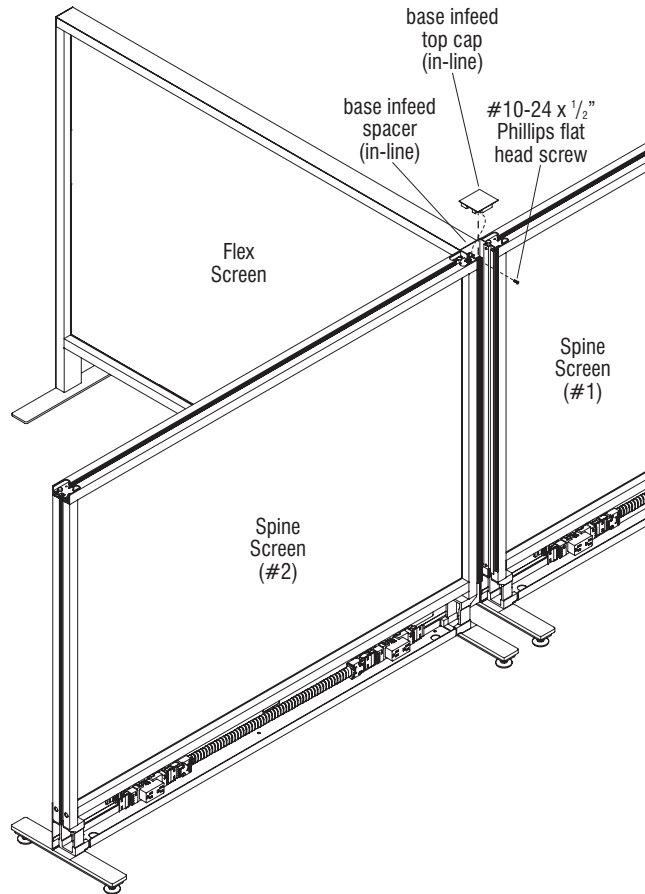
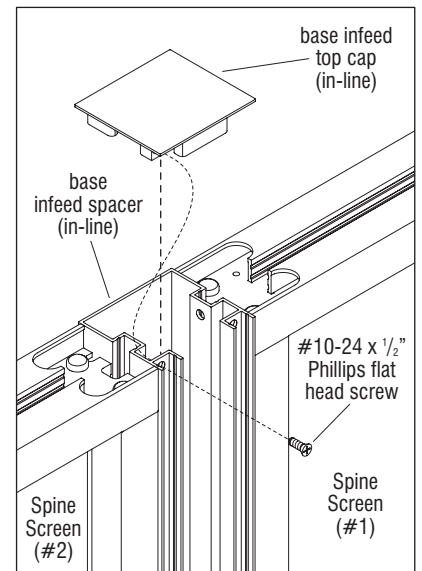

Figure 28



Detail NN



Assemble units as described herein only. To do otherwise may result in instability. All screws, nuts and bolts must be tightened securely and must be checked periodically after assembly. Failure to assemble properly, or to secure parts may result in assembly failure and personal injury.

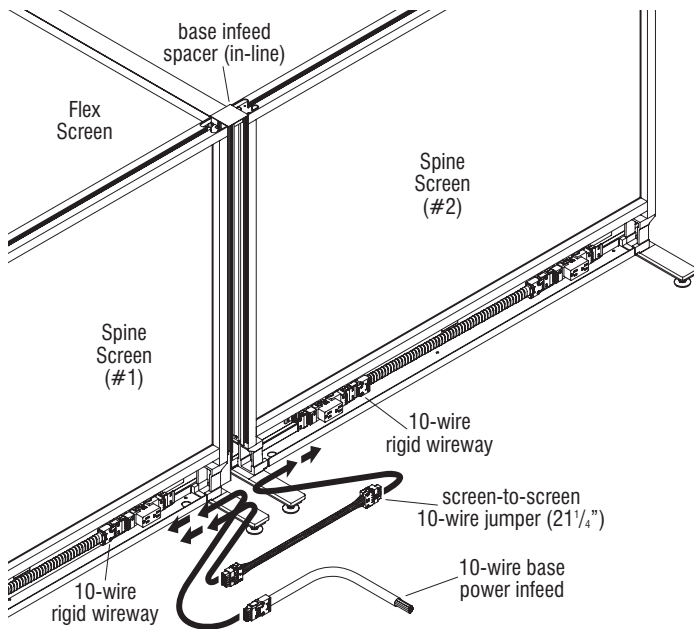

Figure 29

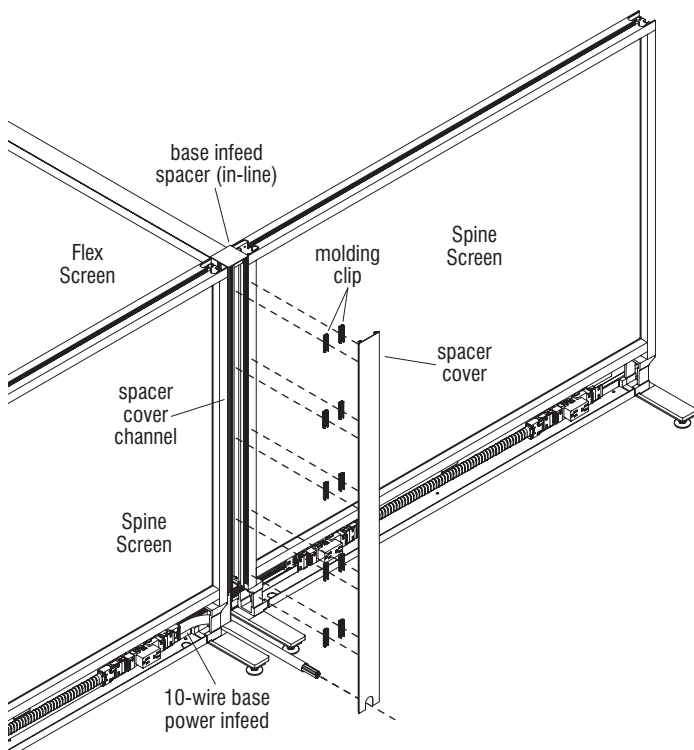
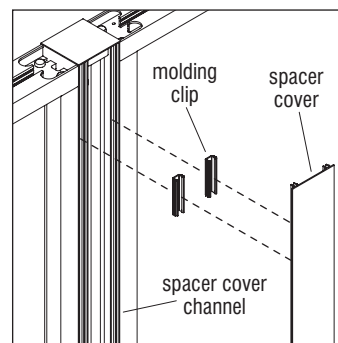

Figure 30



Detail 00

7. At the location specified for a screen-to-screen jumper between the base infeed spacer, route the jumper through the pass-through ankles at each end of the Spine Screen, then plug the ends into each rigid wireway of the powered Spine Screens (Figure 29).
8. Route the 10-wire base power infeed plug end of the infeed through the pass-through ankle and plug it into an open end of a 10-wire rigid wireway (Figure 29).
9. On the rib side of the spacer cover, space molding clips evenly apart and press them onto the ribs of the cover (Figure 30 & Detail 00).
10. Position the spacer cover with molding clips up against the spacer cover channel with the 10-wire base infeed routed through the opening at the bottom of the spacer cover. Using a firm hand, press on the spacer cover at the molding clip locations to snap molding clips into the spacer cover channel (Figure 30 & Detail 00).
11. Reference "Leveling and Connecting Spine Screens" instructions on page 6 to connect remaining screens.

Tattoo™ Screens - Spine Screen Hardwired Electrical

Assembly Instructions



Assemble units as described herein only. To do otherwise may result in instability. All screws, nuts and bolts must be tightened securely and must be checked periodically after assembly. Failure to assemble properly, or to secure parts may result in assembly failure and personal injury.

Hardwired Electrical Base Power Infeed Trim Installation

Note: City of Chicago requires the use of hardwired electrical. Conduit, wiring and receptacles are customer supplied.

Note: The power infeeds are to be connected to the power source by a qualified electrician who must follow all state and local codes at the building site and check the electrical integrity of the finished system.

Note: All screens must be mechanically connected together, with all connections appropriately installed before adding power infeed, or connecting infeed to power source.

1. Per the space-planning layout, determine the location for the hardwired base power infeed. Make sure that the screen to receive the base power infeed is in its final location, and is plumb and level.
2. On the rib side of the base infeed vertical trim, space molding clips evenly apart and press them onto the ribs of the vertical trim as illustrated (Figure 31).
3. Position the base infeed vertical trim with molding clips up against the vertical frame channel that will receive hardwired base power infeed. Align the top of the trim with the bottom of the horizontal frame. Using a firm hand, press along the vertical trim at the molding clip locations to snap clips into the vertical frame channel (Figure 31).
4. Place the end-of-run corner cap into the notch formed on the top corner of the horizontal frame. Align the mounting holes on the horizontal frame with the mounting holes on the corner cap and secure with two #10-24 x 3/8" Torx screws (Figure 31).
5. At the bottom of the screen frame which will receive hardwired base power infeed, follow all state and

local codes at the job site and install conduit, wiring and receptacles per space-planning layout.

6. Install the base raceway trim by aligning the receptacles with the openings in the base raceway trim, then engage the base trim lip with the bottom wireway channel (Figure 32 & Detail PP).

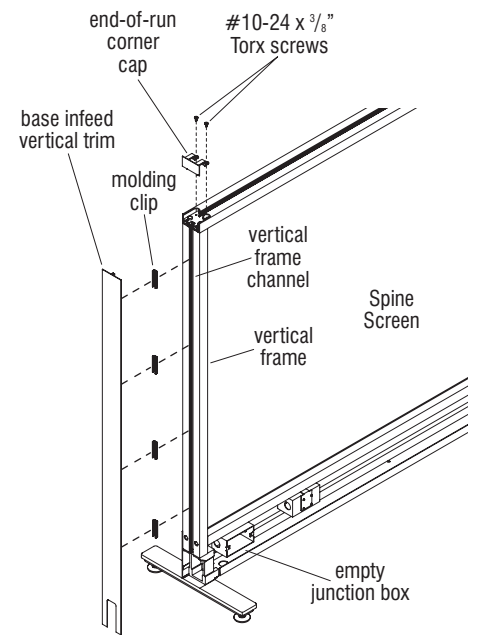
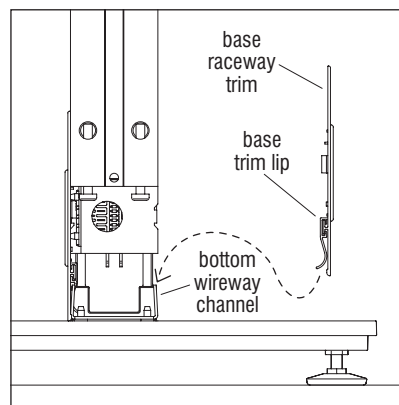

Figure 31



Detail PP

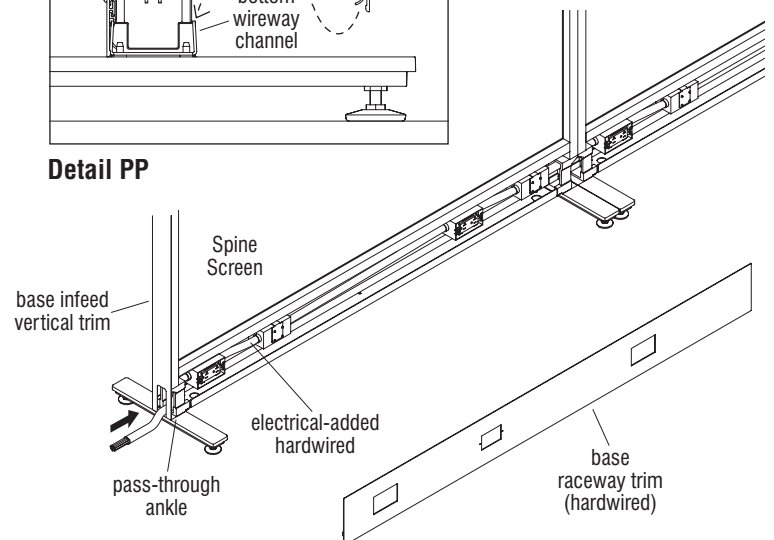
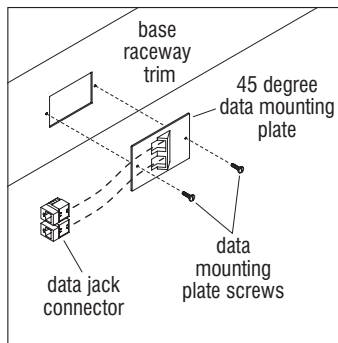

Figure 32



Assemble units as described herein only. To do otherwise may result in instability. All screws, nuts and bolts must be tightened securely and must be checked periodically after assembly. Failure to assemble properly, or to secure parts may result in assembly failure and personal injury.



Detail QQ

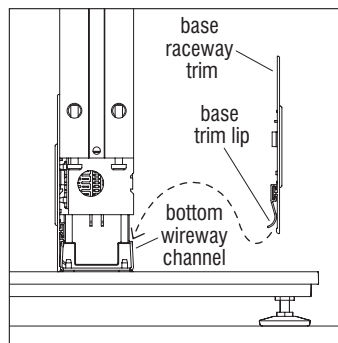

Detail RR

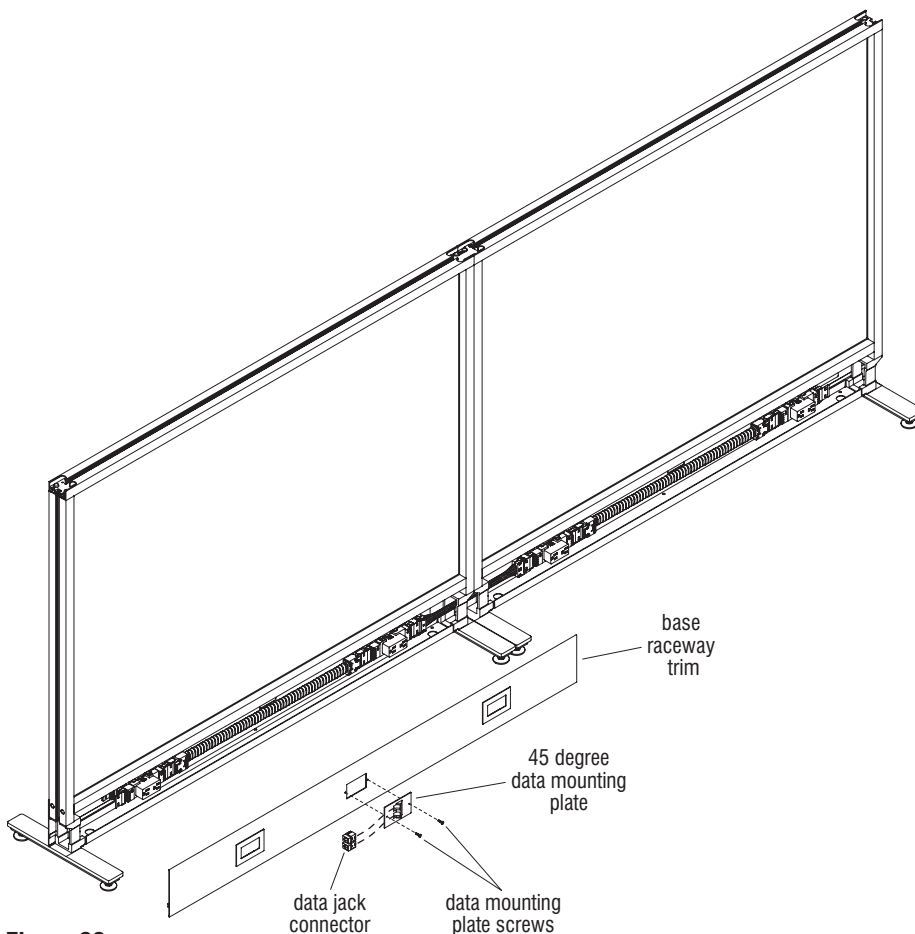

Figure 33

Data Installation

Note: Data cables must only be run after all screens are mechanically connected together, and after all power has been installed.

Note: A 45 degree data mounting plate is required due to limited space in the base raceway channel. Cables, terminations and 45 degree data mounting plates are customer supplied.

1. Per the space-planning layout, determine data jack locations required in base wireway channels. A standard cutout for data plates in base raceway trim is provided (Figure 33).
2. Data cables must be routed and placed underneath the 10-wire rigid wireway, in the bottom wireway channel.
3. Route data wires from their source and along the bottom wireway channel to the desired data jack locations (Detail QQ).
4. Align the holes of the 45 degree data mounting plate with the base raceway trim holes and secure with the screws provided. Make all data jack connections per the manufacturer's specifications.
5. After all data connections have been made, install the base raceway trim by engaging the base trim lip with the bottom wireway channel (Detail RR).

Tattoo™ Screens - Spine Screen Trim

Assembly Instructions



Assemble units as described herein only. To do otherwise may result in instability. All screws, nuts and bolts must be tightened securely and must be checked periodically after assembly. Failure to assemble properly, or to secure parts may result in assembly failure and personal injury.

End-of-Run Spacer Installation

1. Per the space-planning layout, locate the end-of-run screen. Make sure that screen is near its final location and is plumb and level.
2. The screen connector comes with eight molding clips installed (shown uninstalled, Figure 36), four on each side. Position the screen connector up against the vertical frame channel of the Spine Screen, with clips oriented as shown. Using a firm hand, press at the mounting clips on the screen connector, one at a time to seat them into the vertical frame channel at the end of the Spine Screen (Figure 34 & Detail SS).
3. Position the spacer against the vertical frame, with the side opening as desired, and the top facing upward. If the spacer top is higher than the top of the Spine Screen's horizontal frame, the spacer is too tall at the top and must be squarely cut off from the bottom. Cut required amount off the bottom, then press the side of the spacer with the molding clips in the vertical frame channel on the Spine Screen taking care to align the top of the spacer with the top of the screen's horizontal frame. Press forcefully from inside the spacer at the side, to engage the screen connector into the channel of the spacer (Figure 34 & Detail SS).

Note: Two different top caps are available for Tattoo Screen spacers and are labeled so on the bottom of each top cap. An "E" or "I" is displayed on each top cap to represent if the cap is for end-of-run or in-line. As labeled, the top caps are designed to install to a specific spacer. Take care and follow the directions below when installing the top cap. If proper top cap is not installed to the proper spacer, the flat aluminum top cap will not fit correctly, extending too far and disassembly and reassembly will be required.

4. Confirm the base infeed top cap is labelled "E" on the underside for end-of-run. Place the spacer top cap

onto the spacer. Align the mounting hole on the side of the top cap with the mounting hole in the spacer cover channel and secure with a #10-24 x 1/2" Phillips flat head screw. The base infeed top cap will rest flush with the flat aluminum top cap installed in a later step (Figure 34 & Detail SS).

5. On the rib side of the spacer trim, space molding clips evenly apart and press them onto the ribs of the trim (Figure 35 & Detail TT).
6. Position the spacer trim with molding clips up against the spacer. Using a firm hand, press to snap molding clips of the base infeed trim into the vertical spacer channel (Figure 35 & Detail TT).
7. On the rib side of the spacer cover, space molding clips evenly apart and press them onto both ribs on the cover (Figure 35 & Detail UU).
8. Position the spacer cover with molding clips up against the spacer. Using a firm hand, press to snap molding clips of the spacer cover into the spacer cover channel (Figure 35 & Detail UU).

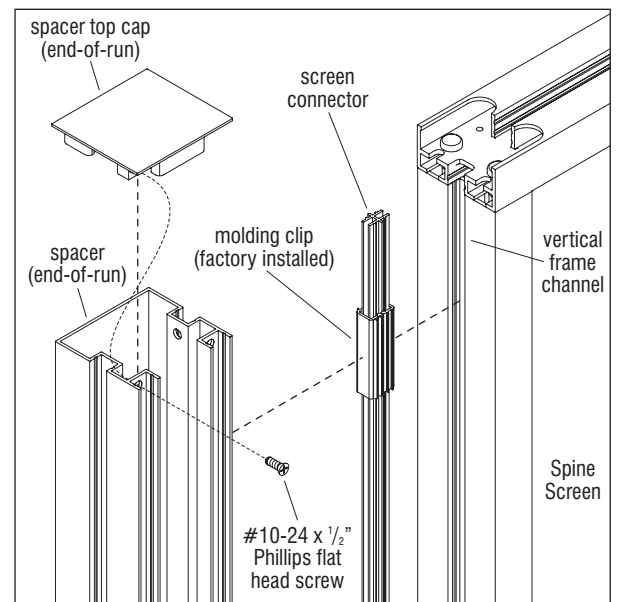

Detail SS

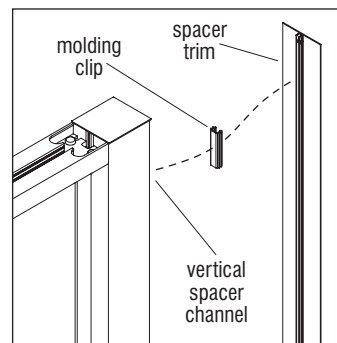

Detail TT

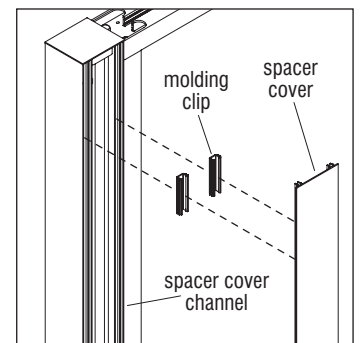

Detail UU

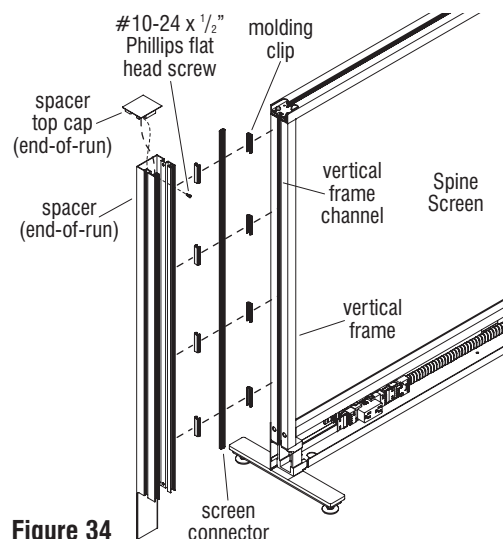

Figure 34

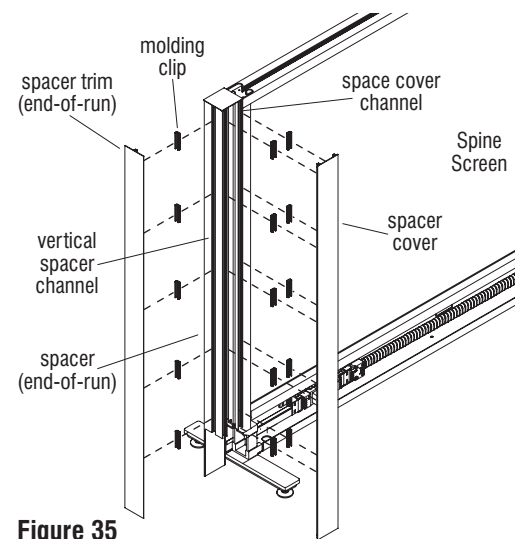
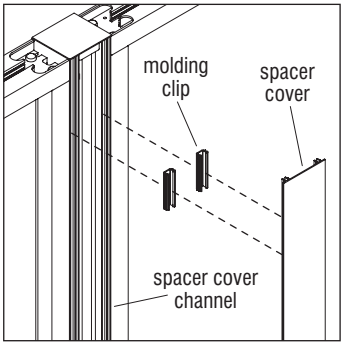

Figure 35



Assemble units as described herein only. To do otherwise may result in instability. All screws, nuts and bolts must be tightened securely and must be checked periodically after assembly. Failure to assemble properly, or to secure parts may result in assembly failure and personal injury.



Detail VV

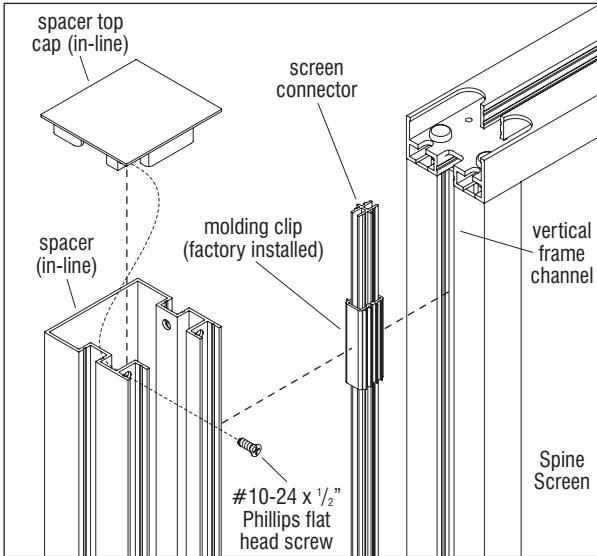

Detail WW

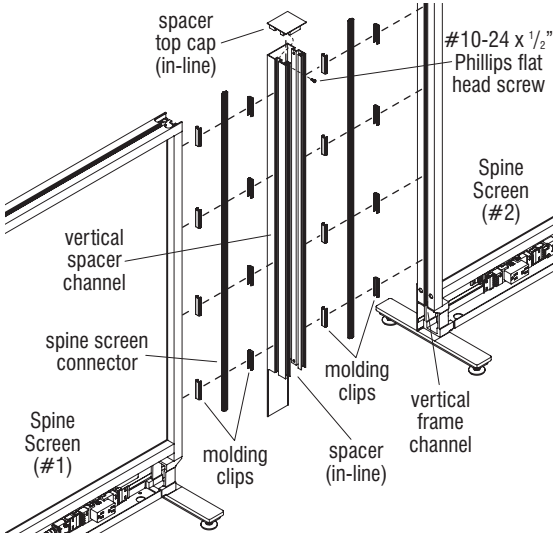

Figure 36

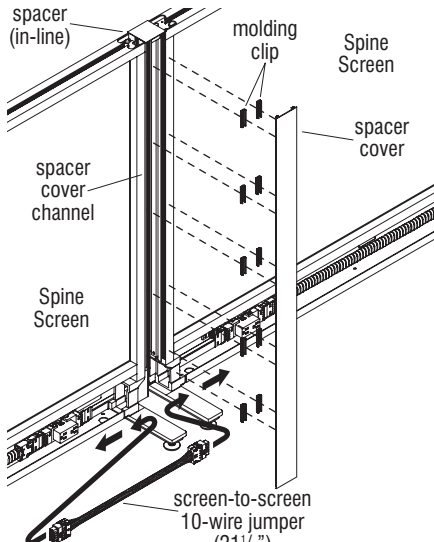

Figure 37

In-Line Spacer Installation

Note: All screens must be mechanically connected together, with all 10-wire rigid wireways and screen-to-screen power connections appropriately installed before adding power infeed, or connecting infeed to power source.

Note: The power infeeds are to be connected to the power source by a qualified electrician who must follow all state and local codes at the building site and check the electrical integrity of the finished system.

1. Per the space-planning layout, determine the location for in-line spacer. Make sure that the screens to receive the spacer are near their final location, and are plumb and level.
2. The two required screen connectors come with eight molding clips installed to each (shown uninstalled, Figure 36), four on each side. At each Spine Screen end, as illustrated, position the screen connector up against the vertical frame channel of the Spine Screen, with clips oriented as shown. Using a firm hand, press at the mounting clips on the screen connector, one at a time to seat them into the vertical frame channel at the end of the Spine Screen (Figure 36 & Detail WW).
3. Position the spacer against the vertical frame, with the side opening as desired, and the top facing upward. If the base spacer top is higher than the top of the Spine Screen's horizontal frame, the spacer is too tall at the top and must be

squarely cut off from the bottom. Cut required amount off the bottom, then press the side of the spacer with the molding clips in the vertical frame channel on the Spine Screen taking care to align the top of the base infeed spacer with the top of the screen's horizontal frame. Press forcefully from inside the spacer, to engage the screen connector/ clips of Spine Screen #1 into the channel of the base infeed spacer. Next, move Spine Screen #2 over to align its installed screen connector/ clips with the appropriate vertical spacer channel. Level and plumb Spine Screen #2 to #1 by twisting the height-adjustable glides clockwise or counter-clockwise until the frame's vertical edges are aligned and tops of screens are at the same height. Press Spine Screen #2 into the vertical spacer channel to engage such that both Spine Screens are snapped into the spacer (Figure 36 & Detail WW).

4. Confirm the spacer top cap is labelled "1" on the underside for in-line. Place the spacer top cap onto the base spacer. Align the mounting hole on the side of the top cap with the mounting hole in the spacer cover channel and secure with a #10-24 x 1/2" Phillips flat head screw. The spacer top cap will rest flush with the flat aluminum top cap installed in a later step (Figure 36 & Detail WW).

5. At the location specified for a screen-to-screen jumper between the spacer, route the jumper through the pass-through ankles at each end of the Spine Screen, then plug the ends into each rigid wireway of the powered Spine Screens (Figure 37).

6. On the rib side of the spacer cover, space molding clips evenly apart and press them onto the ribs of the cover (Figure 37 & Detail VV).

7. Position the spacer cover with molding clips up against the spacer cover channel. Using a firm hand, press on the spacer cover at the molding clip locations to snap molding clips into the spacer cover channel (Figure 37 & Detail VV).

Tattoo™ Screens - Spine Screen Trim

Assembly Instructions



Assemble units as described herein only. To do otherwise may result in instability. All screws, nuts and bolts must be tightened securely and must be checked periodically after assembly. Failure to assemble properly, or to secure parts may result in assembly failure and personal injury.

In-Line Spacer Installation with Flex Screen Intersection

Note: All screens must be mechanically connected together, with all 10-wire rigid wireways and screen-to-screen power connections appropriately installed before adding power infeed, or connecting infeed to power source.

Note: The power infeeds are to be connected to the power source by a qualified electrician who must follow all state and local codes at the building site and check the electrical integrity of the finished system.

1. Per the space-planning layout, determine the location for in-line spacer. Make sure that the screens to receive the spacer are near their final location, and are plumb and level.
2. The two required screen connectors come with eight molding clips installed to each (shown uninstalled, Figure 38), four on each side. At Spine Screen #1's end, as illustrated, position the screen connector up against the vertical frame channel of Spine Screen #1, with clips oriented as shown. Using a firm hand, press at the mounting clips on the screen connector, one at a time to seat them into the vertical frame channel at the end of the Spine Screen #1 (Figure 38 & Detail XX).
3. Position the spacer as illustrated with the bottom backside "tongue" facing the end of the adjoining Flex Screen to install. If the spacer top is higher than the top of the Spine Screen #1's horizontal frame, the spacer is too tall at the top and must be squarely cut off from the bottom. Cut required amount off the bottom, then press the side of the spacer with the molding clips in the vertical frame channel on Spine Screen #1 taking care to align the top of the spacer with the top of the screen's horizontal frame. Press forcefully from inside the spacer, to engage the screen connector/clips of Spine Screen #1 into the channel of the spacer into an open end of a 10-wire rigid wireway (Figure 38).

4. Carefully lift and arrange the Flex Screen foot under the perpendicular Spine Screen foot, aligning the Flex Screen against the spacer during the process (Figure 38).

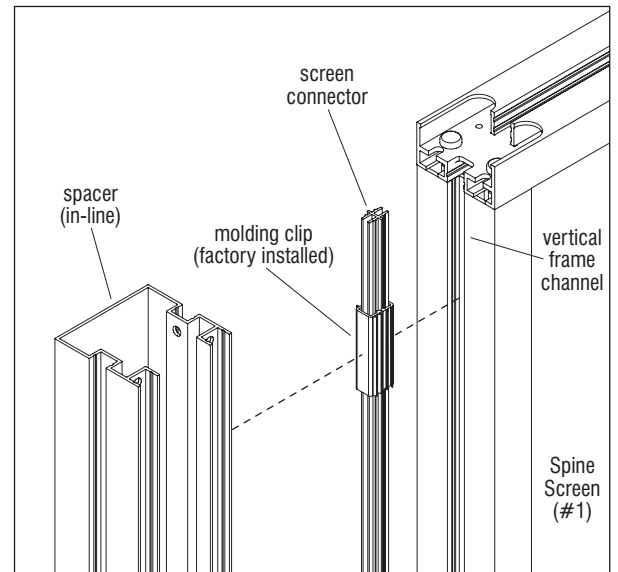

Detail XX

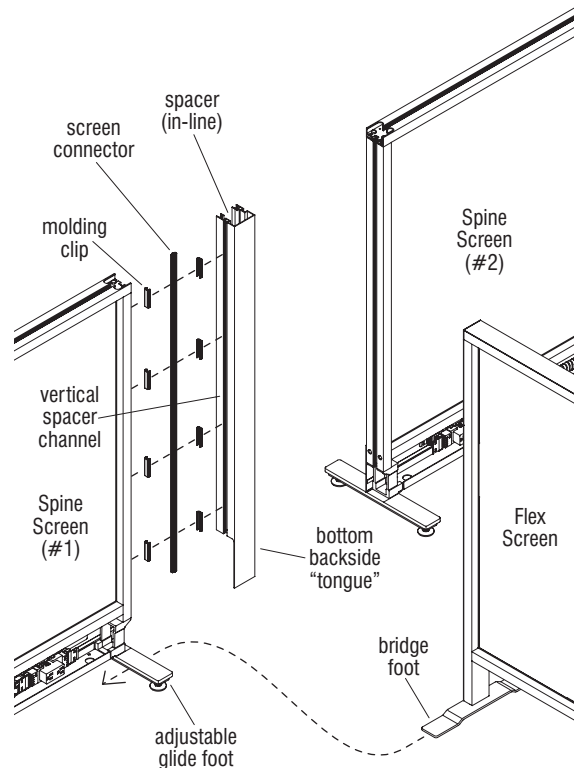
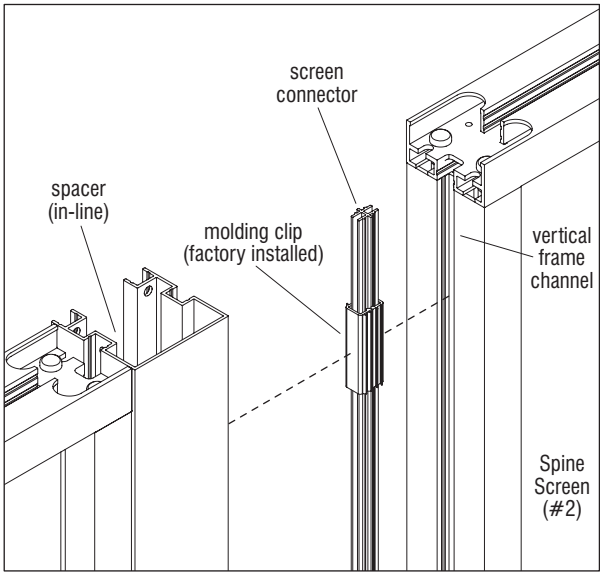

Figure 38



Assemble units as described herein only. To do otherwise may result in instability. All screws, nuts and bolts must be tightened securely and must be checked periodically after assembly. Failure to assemble properly, or to secure parts may result in assembly failure and personal injury.



Detail YY

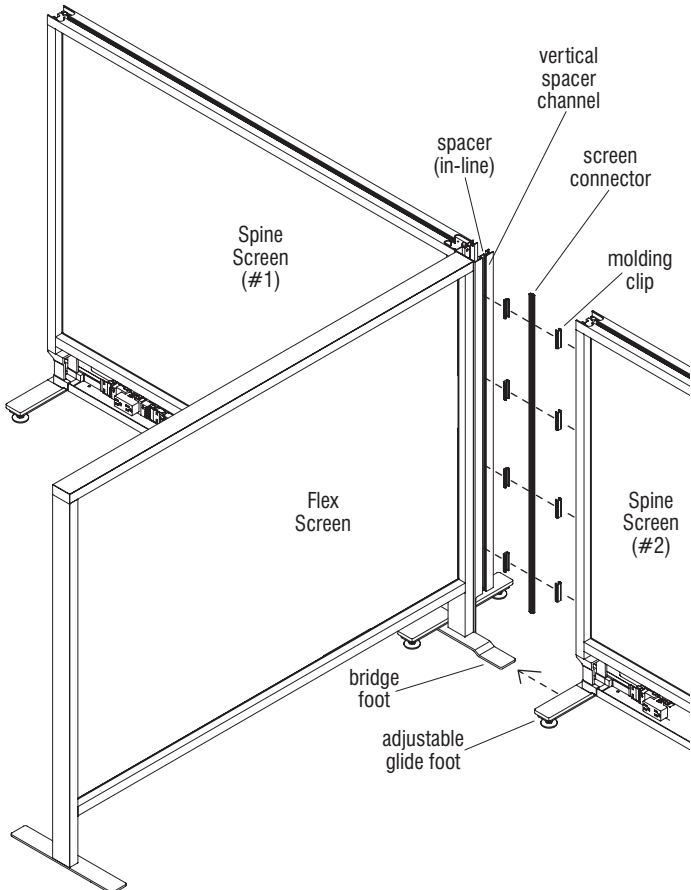
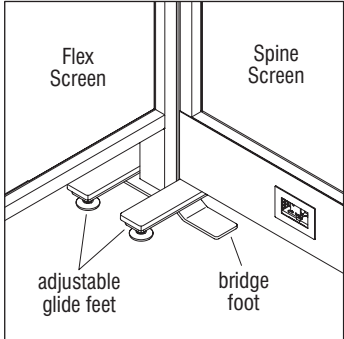

Figure 39

- Carefully lift and arrange Spine Screen #2 so that the adjustable foot is over the foot of the Flex Screen (Detail ZZ). Move Spine Screen #2 over to align its installed screen connector/clips with the appropriate power pole channel. Level and plumb Spine Screen #2 to #1 by twisting the height-adjustable glides clockwise or counter-clockwise until the frame's vertical edges are aligned and tops of screens are at the same height. Press Spine Screen #2 screen connector/clips into the vertical spacer channel to engage such that both Spine Screens are snapped into the in-line spacer (Figure 39 & Detail YY).



Detail ZZ - Spine Screen 3-Way Intersection with Flex Screen (adjustable feet over bridge foot)

Tattoo™ Screens - Spine Screen Trim

Assembly Instructions



Assemble units as described herein only. To do otherwise may result in instability. All screws, nuts and bolts must be tightened securely and must be checked periodically after assembly. Failure to assemble properly, or to secure parts may result in assembly failure and personal injury.

In-Line Spacer Installation with Flex Screen Intersection (cont.)

Note: Two different top caps are available for Tattoo Screen spacers and are labeled so on the bottom of each top cap. An "E" or "I" is displayed on each top cap to represent if the cap is for end-of-run or in-line. As labeled, the top caps are designed to install to a specific spacer. Take care and follow the directions below when installing the top cap. If top cap is not installed to the proper spacer, the flat aluminum top cap will not fit correctly, extending too far and disassembly and reassembly will be required.

6. Confirm the spacer top cap is labelled "I" on the underside for inline. Place the top cap onto the spacer. Align the mounting hole on the side of the top cap with the mounting hole in the spacer cover channel and secure with a #10-24 x 1/2" Phillips flat head screw. The spacer top cap will rest flush with the flat aluminum top cap installed in a later step (Figure 40 & Detail AAA).

Note: Each powered Spine Screen has two 10-wire rigid wireways that are pre-mounted in the base raceway at the factory.

Note: Spine Screen electrical is "in-line" only and does not turn corners. Spine Screens cannot pass power to Flex Screens.

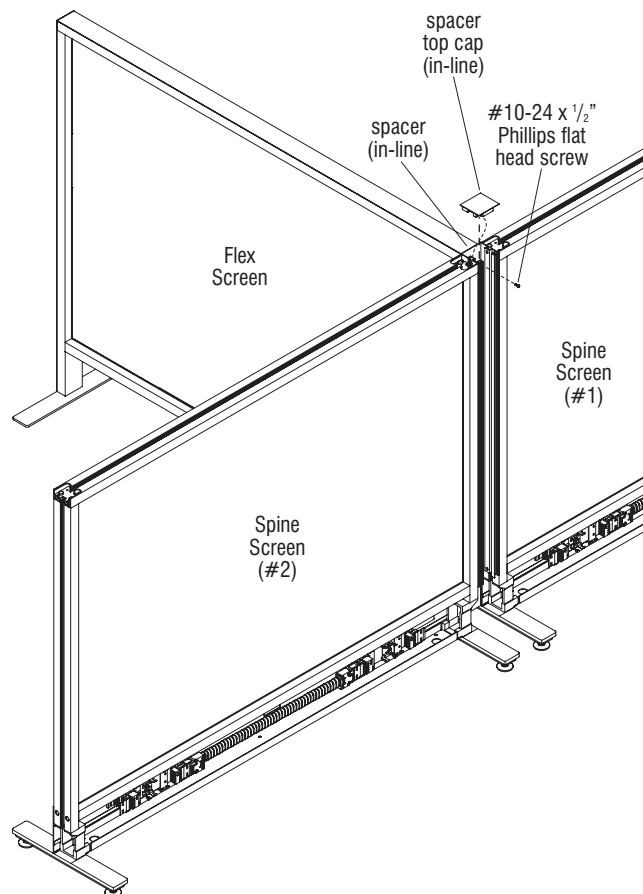
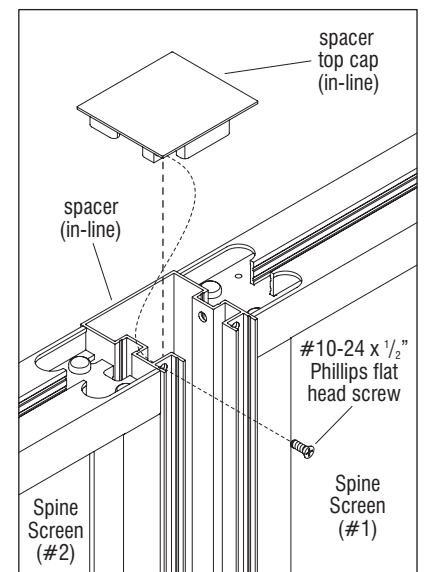

Figure 40



Detail AAA



Assemble units as described herein only. To do otherwise may result in instability. All screws, nuts and bolts must be tightened securely and must be checked periodically after assembly. Failure to assemble properly, or to secure parts may result in assembly failure and personal injury.

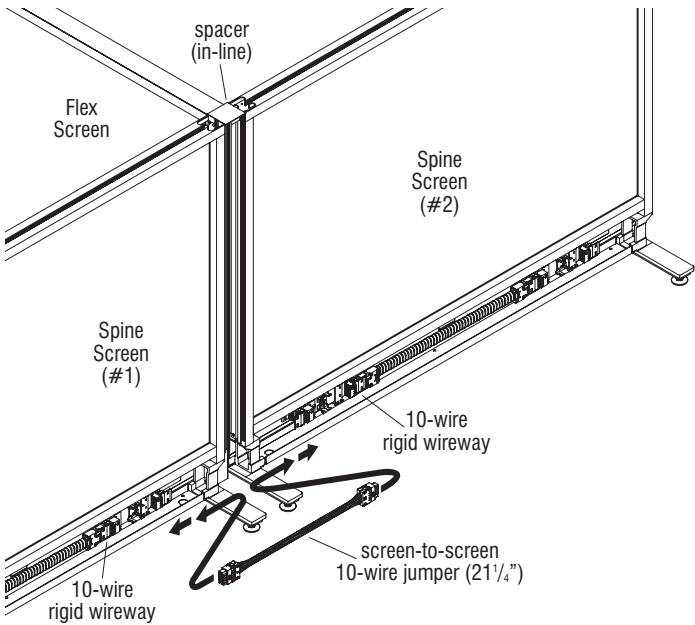

Figure 41

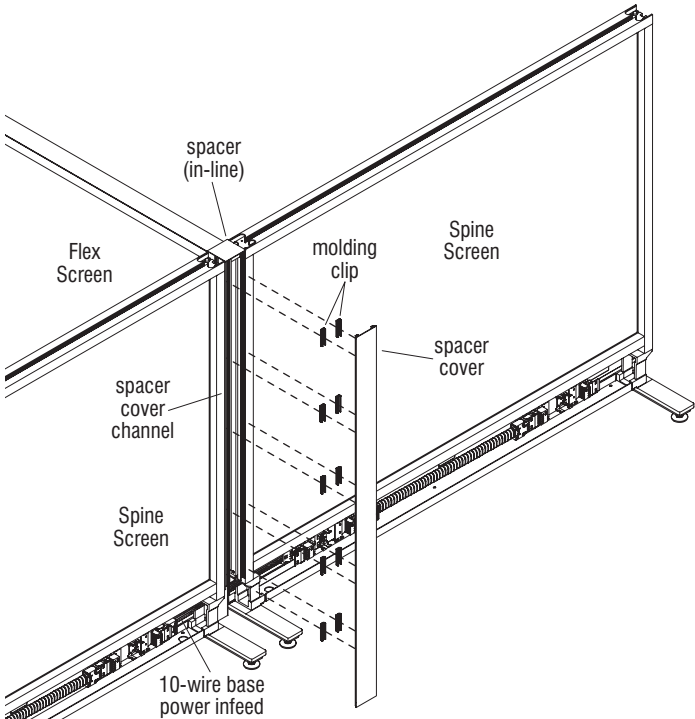
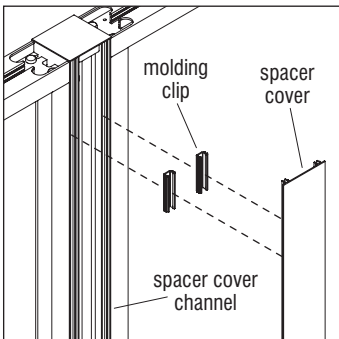

Figure 42



Detail BBB

7. At the location specified for a screen-to-screen jumper between the spacer, route the jumper through the pass-through ankles at each end of the Spine Screen, then plug the ends into each rigid wireway of the powered Spine Screens (Figure 41).
8. Route the 10-wire base power infeed plug end of the infeed through the pass-through ankle and plug it into an open end of a 10-wire rigid wireway (Figure 41).
9. On the rib side of the spacer cover, space molding clips evenly apart and press them onto the ribs of the cover (Figure 41 & Detail BBB).
10. Position the spacer cover with molding clips up against the spacer cover channel with the 10-wire base infeed routed through the opening at the bottom of the spacer cover. Using a firm hand, press on the spacer cover at the molding clip locations to snap molding clips into the spacer cover channel (Figure 42 & Detail BBB).
11. Reference "Leveling and Connecting Spine Screens" instructions on page 6 to connect remaining screens.

■ Tattoo™ Screens - Spine Screen Trim

Assembly Instructions



Assemble units as described herein only. To do otherwise may result in instability. All screws, nuts and bolts must be tightened securely and must be checked periodically after assembly. Failure to assemble properly, or to secure parts may result in assembly failure and personal injury.

10-Wire Base Raceway Trim Installation

Note: The power infeeds are to be connected to the power source by a qualified electrician who must follow all state and local codes at the building site and check the electrical integrity of the finished system.

Note: All screens must be mechanically connected together, with all 10-wire rigid wireways and screen-to-screen power connections appropriately installed before adding power infeed, or connecting infeed to power source.

1. Install the base raceway trim by aligning the trim openings with the installed receptacle and engaging the base trim lip with the bottom wireway channel (Figure 43 & Detail CCC).

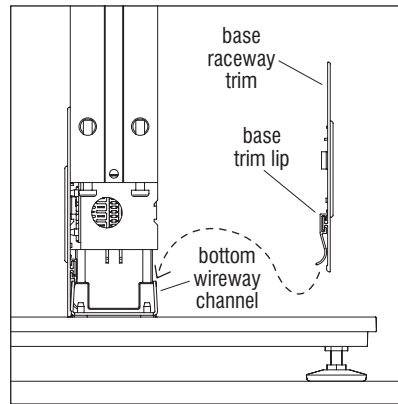

Detail CCC

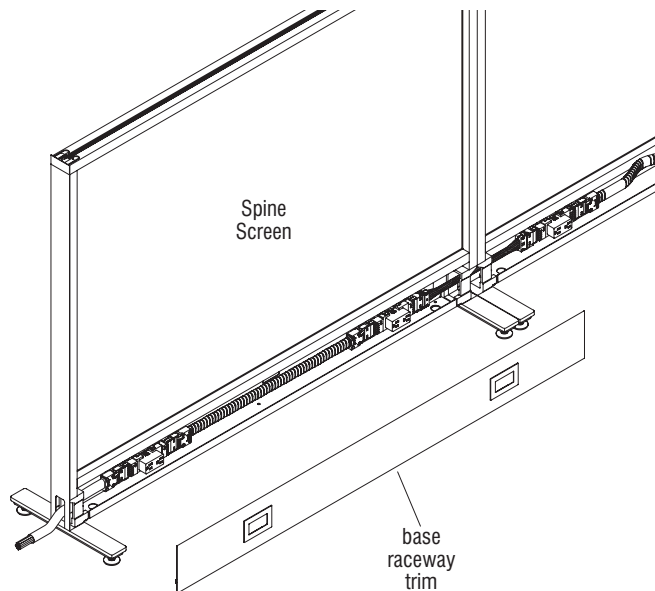

Figure 43



Assemble units as described herein only. To do otherwise may result in instability. All screws, nuts and bolts must be tightened securely and must be checked periodically after assembly. Failure to assemble properly, or to secure parts may result in assembly failure and personal injury.

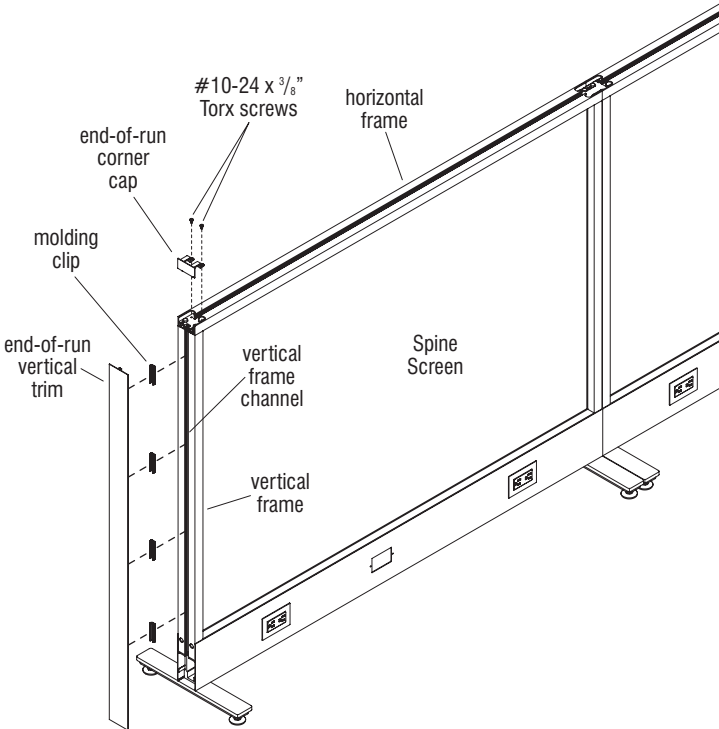

Figure 44

End-of-Run Vertical Trim Installation

1. Per the space-planning layout, locate the end-of-run screen. Make sure that screen is plumb and level.
2. Determine the length of the end-of-run vertical trim by measuring the distance from the top of the Spine Screen vertical frame, down to the floor at the end-of-run trim location. Cut the trim to the marked length.
3. On the rib side of the end-of-run vertical trim, space molding clips evenly apart and press them onto the ribs of the end-of-run trim as illustrated (Figure 44).
4. Position the end-of-run vertical trim with molding clips up against the vertical frame channel. Using a firm hand, press on the vertical trim at the molding clip locations to snap molding clips into the vertical frame channel (Figure 44).
5. Place the end-of-run corner cap into the notch formed on the top corner of the horizontal frame. Align the mounting holes on the horizontal frame with the mounting holes on the corner cap and secure with two #10-24 x 3/8" Torx screws (Figure 44).

Note: If Spine Screen is specified with a topper kit and no Flex Screen configurations are required, proceed to page 47 for "Topper Kit Installation" instructions. If Flex Screen configurations will be configured with Spine Screen configurations and topper kits are specified, proceed to page 42 for "Flex Screen Configurations" instructions. If Spine Screen are not specified with topper kits proceed to "Flat Aluminum Top Cap Installation" instructions on page 41.

Tattoo™ Screens - Spine Screen Trim

Assembly Instructions



Assemble units as described herein only. To do otherwise may result in instability. All screws, nuts and bolts must be tightened securely and must be checked periodically after assembly. Failure to assemble properly, or to secure parts may result in assembly failure and personal injury.

Change-of-Height Trim Installation

1. Per the space-planning layout, locate the change-of-height screens. Make sure that screens are plumb and level.
2. Determine the length of the vertical trim for the change-of-height screens by measuring the distance from the bottom of the vertical frame of the taller Spine Screen, down to the top of the lower Spine Screen frame at the vertical trim location. Cut the vertical trim to the marked length.
3. On the rib side of the vertical trim, space molding clip(s) evenly apart and press them onto the rib of the vertical trim as illustrated (Figure 45).
4. Position the vertical trim with molding clip(s) up against the vertical frame channel. Using a firm hand, press on the trim at the molding clips to snap molding clips into the vertical frame channel (Figure 45).
5. Place the end-of-run corner cap into the notch formed on the top corner of the horizontal frame. Align the mounting holes on the horizontal frame with the mounting holes on the corner cap and secure with two #10-24 x 3/8" Torx screws (Figure 45).

Note: If Spine Screen is specified with a topper kit and no Flex Screen configurations are required, proceed to page 47 for "Topper Kit Installation" instructions. If Flex Screen configurations will be configured with Spine Screen configurations and topper kits are specified, proceed to page 42 for "Flex Screen Configurations" instructions. If Spine Screen are not specified with topper kits proceed to "Flat Aluminum Top Cap Installation" instructions on page 41.

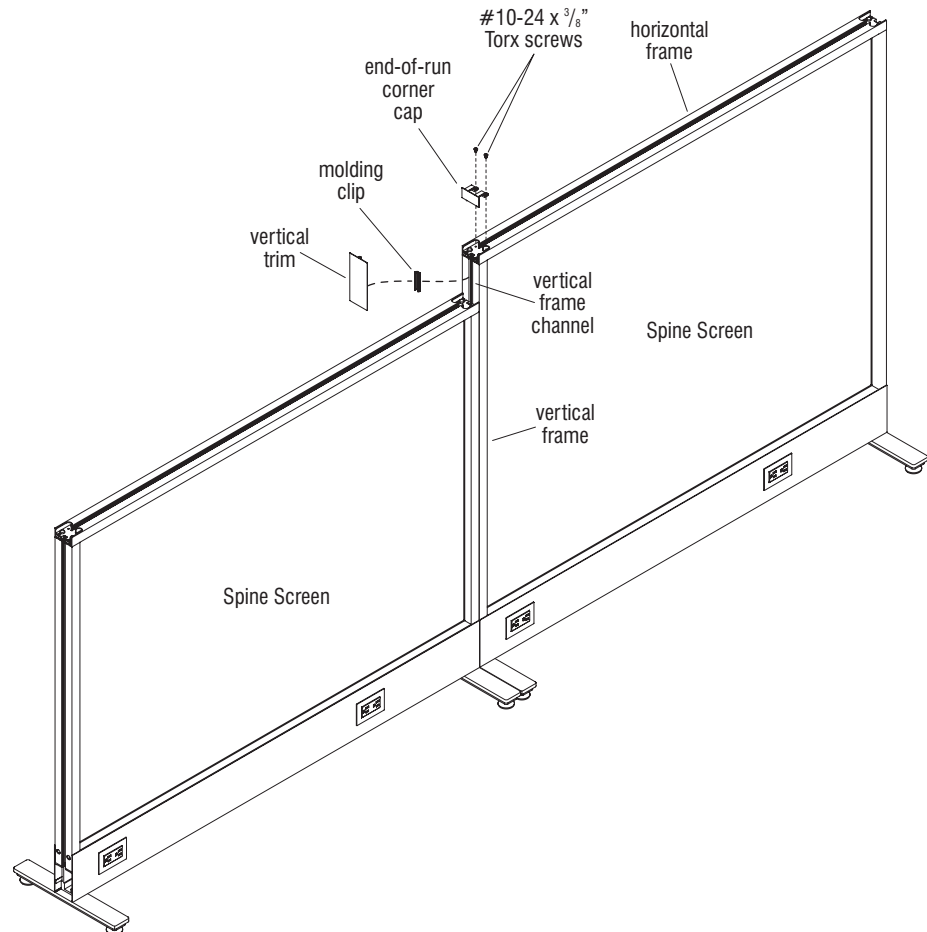

Figure 45



Assemble units as described herein only. To do otherwise may result in instability. All screws, nuts and bolts must be tightened securely and must be checked periodically after assembly. Failure to assemble properly, or to secure parts may result in assembly failure and personal injury.

Flat Aluminum Top Cap Installation

1. On the rib side of the flat aluminum top cap, space molding clips evenly apart and press them onto the ribs of the top cap as illustrated (Figure 46).
2. Position the flat aluminum top cap with molding clips down against the horizontal frame channel. Using a firm hand, press on the top cap at the molding clip location to snap molding clips into the horizontal frame channel (Figure 46).

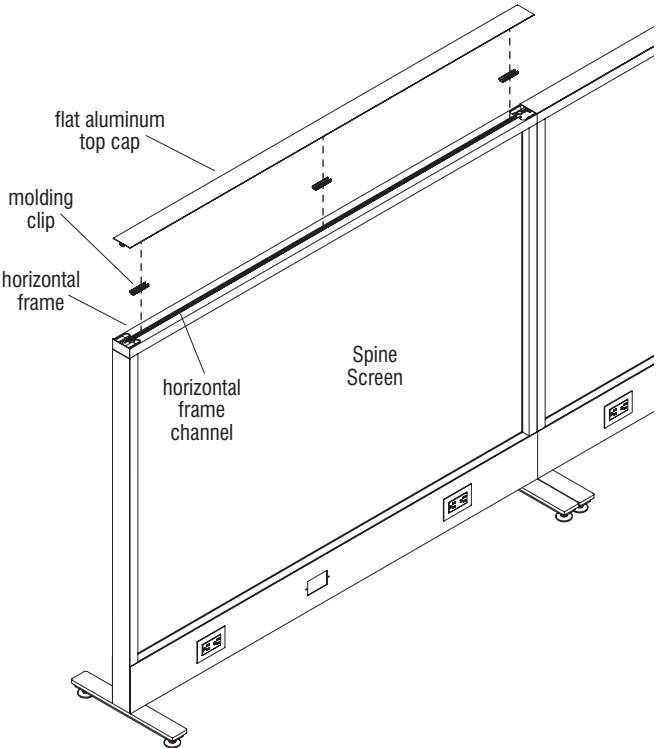

Figure 46

Tattoo™ Screens - Flex Screen

Assembly Instructions



Assemble units as described herein only. To do otherwise may result in instability. All screws, nuts and bolts must be tightened securely and must be checked periodically after assembly. Failure to assemble properly, or to secure parts may result in assembly failure and personal injury.

Flex Screen Configurations

Note: Flex Screens are free standing, non-powered screens designed to allow various screen intersection options. Each Flex Screen is either equipped with two adjustable glide feet or one bridge foot and one flat foot, to be used in 90 degree configurations. See instructions on pages 42-46 to properly arrange the various Flex Screen intersection configurations.

In-Line Flex Screens

Note: Reference Details A, B, C & D for in-line Flex Screen configuration options.

1. Carefully lift and arrange Flex Screens in-line to each other per the space-planning layout (Figure 1). If screens are to install in-line in preparation for a 3-way intersection as illustrated on page 45 (Figure 4), move screens in-line to one another so that the flat foot of one screen is adjacent to the flat foot of the adjacent screen (Detail B).

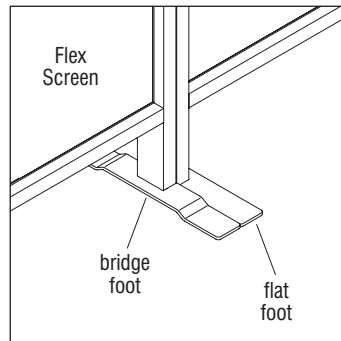

Detail A - In-Line Flex Screens (bridge foot-to-flat foot)

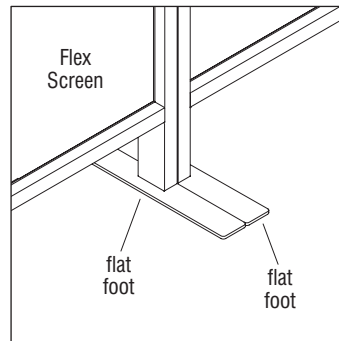

Detail B - In-Line Flex Screens (flat foot-to-flat foot)

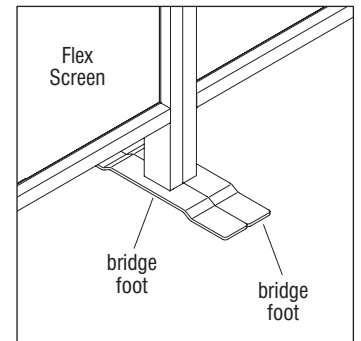

Detail C - In-Line Flex Screens (bridge foot-to-bridge foot)

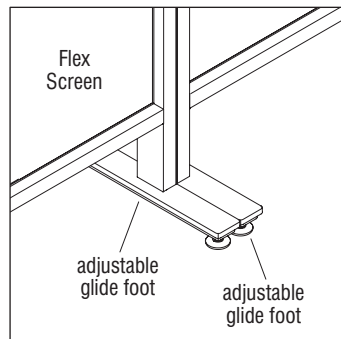

Detail D - In-Line Flex Screens (adjustable glide foot-to-adjustable glide foot)

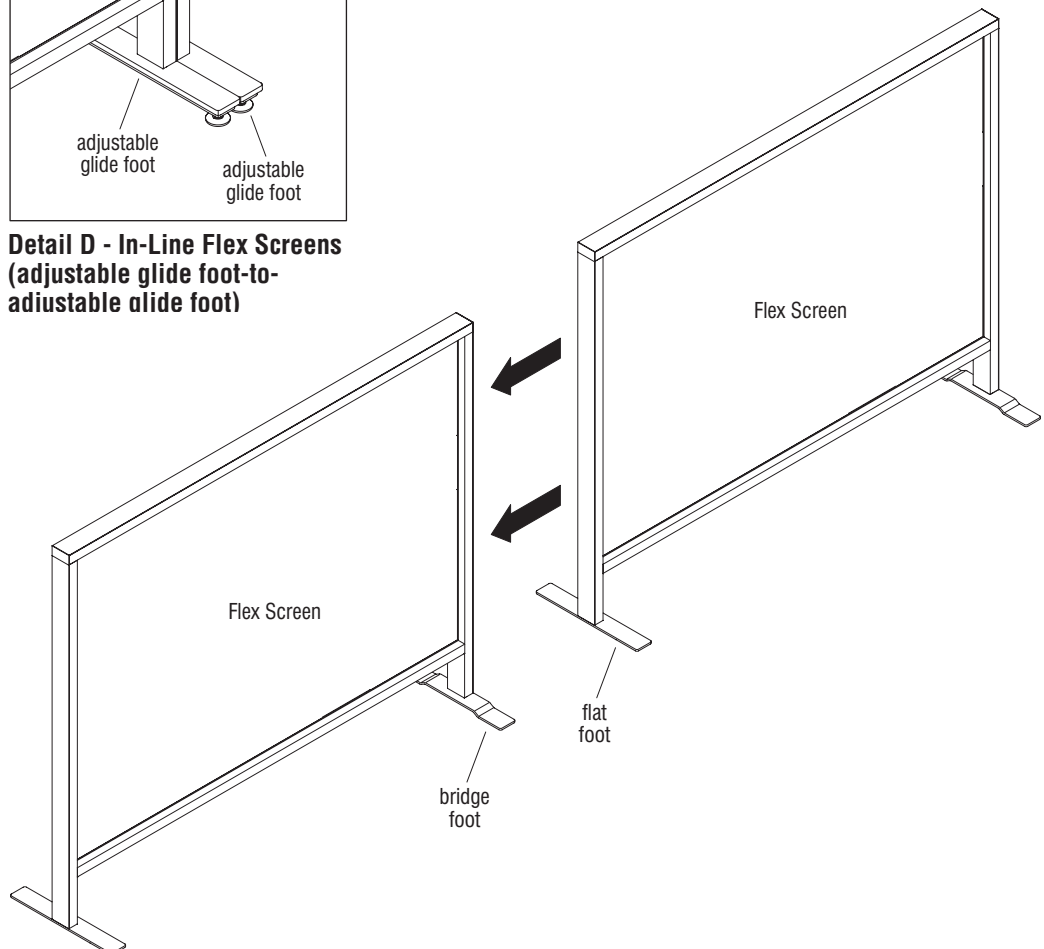
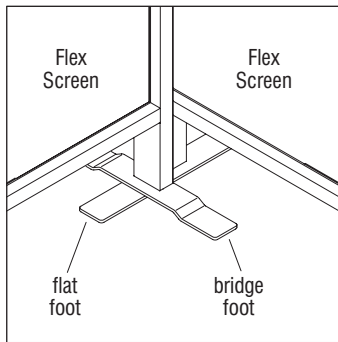

Figure 1 - In-Line Flex Screens



Assemble units as described herein only. To do otherwise may result in instability. All screws, nuts and bolts must be tightened securely and must be checked periodically after assembly. Failure to assemble properly, or to secure parts may result in assembly failure and personal injury.



Detail E - Flex Screen Corner Intersection (bridge foot over flat foot)

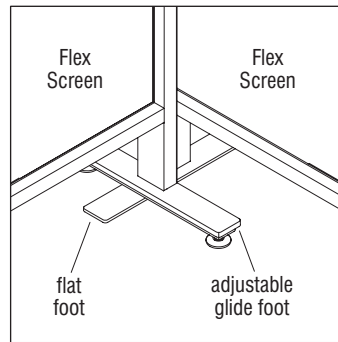

Detail F - Flex Screen Corner Intersection (adjustable glide foot over flat foot)

Flex Screen Corner Intersections

Note: Flex Screens in the corner intersection configuration must be placed perpendicular to each other. One screen must have the bridge or adjustable glide foot rest on top of the perpendicular screen's flat foot. Reference Details E & F for Flex Screen corner intersection configuration options.

1. Carefully lift and arrange the Flex Screens to be perpendicular to each other per the space-planning layout. Place the screen with the bridge or adjustable glide foot over the perpendicular screens flat foot or slide the screen with the flat foot under the bridge or adjustable glide foot of the perpendicular screen (Figure 2).

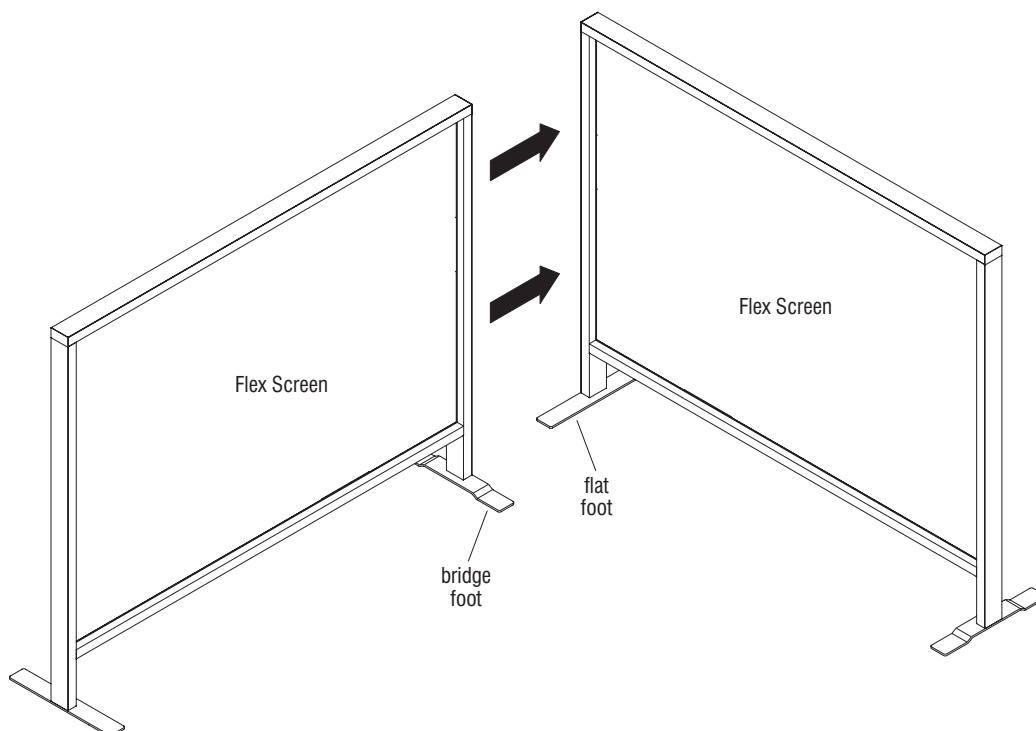

Figure 2 - Flex Screen Corner Intersection



Assemble units as described herein only. To do otherwise may result in instability. All screws, nuts and bolts must be tightened securely and must be checked periodically after assembly. Failure to assemble properly, or to secure parts may result in assembly failure and personal injury.

Flex Screen Mid-Panel Intersections

Note: Flex Screens in the mid-panel intersection configuration must be placed perpendicular to each other. One screen will be placed up against the middle of the perpendicular screen. Feet do not intersect in mid-panel intersection configurations. Reference Details G & H for Flex Screen mid-panel intersection configuration options.

1. Carefully lift and arrange the Flex Screens to be perpendicular to each other, with one screen up against the middle of the perpendicular screen per the space-planning layout (Figure 3).

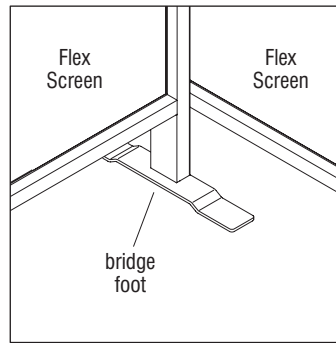

Detail G - Flex Screen Mid-Panel Intersection

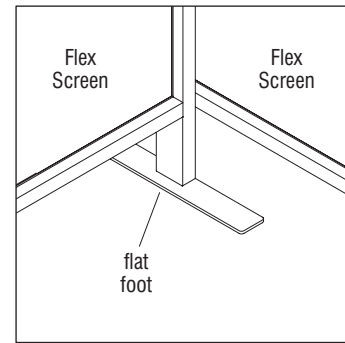

Detail H - Flex Screen Mid-Panel Intersection

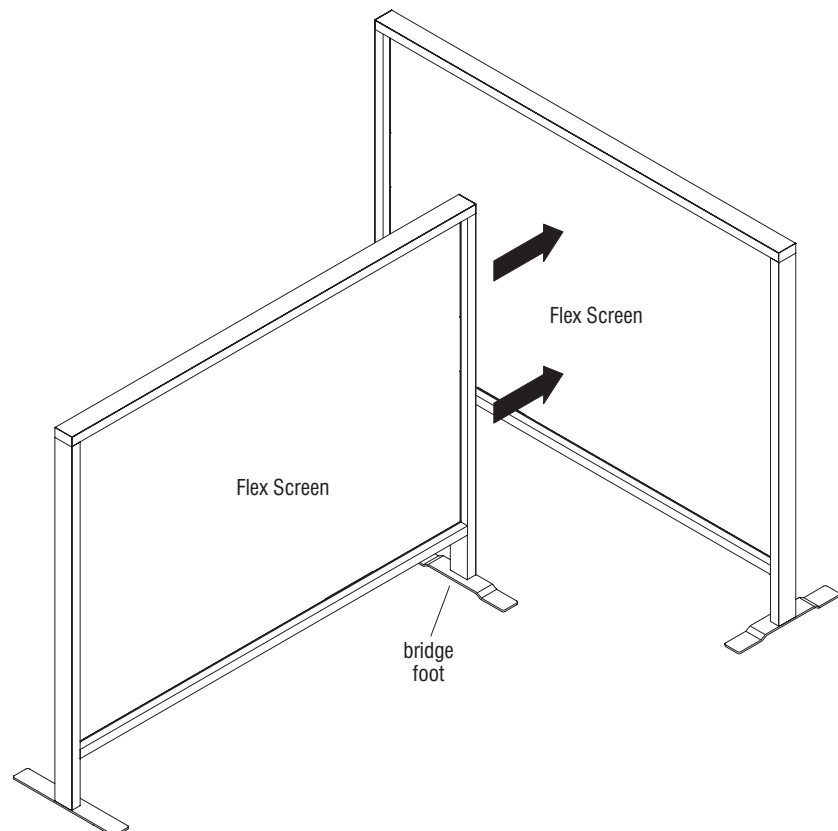
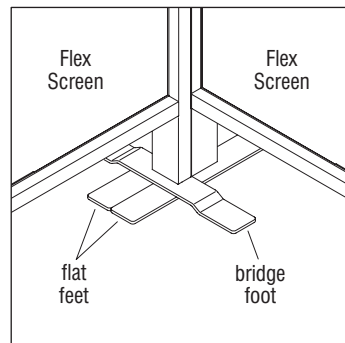

Figure 3 - Flex Screen Mid-Panel Intersection



Assemble units as described herein only. To do otherwise may result in instability. All screws, nuts and bolts must be tightened securely and must be checked periodically after assembly. Failure to assemble properly, or to secure parts may result in assembly failure and personal injury.



Detail I - Flex Screen 3-Way Intersection (bridge foot over flat feet)

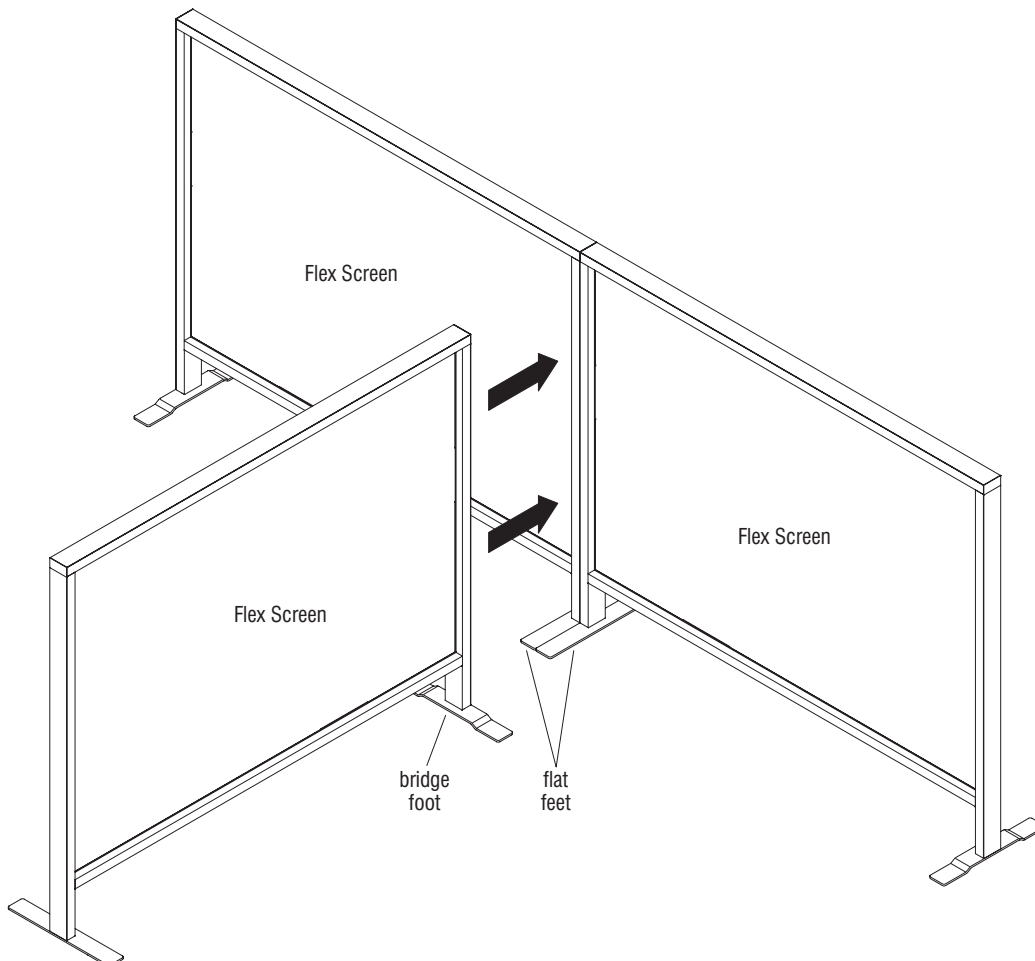

Figure 4 - Flex Screen 3-Way Intersection

Flex Screen 3-Way Intersections

Note: If the Flex Screen 3-way intersection will be configured, the in-line Flex Screen configuration must be assembled first before proceeding. Reference "In-Line Flex Screen" instructions on page 42.

Note: The in-line Flex Screens in the 3-Way configuration must be placed together with the flat feet adjacent to each other. The perpendicular screen must have the bridge or adjustable glide foot bridge over the in-line screen's flat feet. Reference Detail I for Flex Screen 3-way intersection configuration option.

1. With the in-line Flex Screen in its final location, carefully lift and arrange the perpendicular Flex Screen to the 3-way location per the space-planning layout (Figure 4).
2. Place the screen with the bridge or adjustable glide foot over the in-line screen's flat feet (Figure 4).



Assemble units as described herein only. To do otherwise may result in instability. All screws, nuts and bolts must be tightened securely and must be checked periodically after assembly. Failure to assemble properly, or to secure parts may result in assembly failure and personal injury.

Spine & Flex Screen 3-Way Intersections

Note: If the Spine and Flex Screen 3-way intersection will be configured, in-line Spine Screens must be assembled and connected first before proceeding. Reference "Leveling & Connecting Spine Screens" on page 6, then reference appropriate electrical instructions on pages 9-41. In-line Flex Screens will be configured in the steps below since Spine Screens must remain stationary.

Note: If both Spine & Flex Screens are to be used in a 3-way intersection configuration, the Flex Screen will be moved and placed up against the Spine Screen in their final location. Spine Screens must not be moved during the installation since screens were adjusted for flooring conditions, ganged and contain power (optional) from previous steps.

Note: The in-line Flex Screens feet in the 3-Way configuration must be placed individually under the perpendicular Spine Screen adjustable glide foot. Once both in-line Flex Screen feet are under the perpendicular Spine Screen foot, carefully place the two in-line Flex Screens against each other. Reference Details J, K and L for Spine & Flex Screen 3-way intersection configuration options.

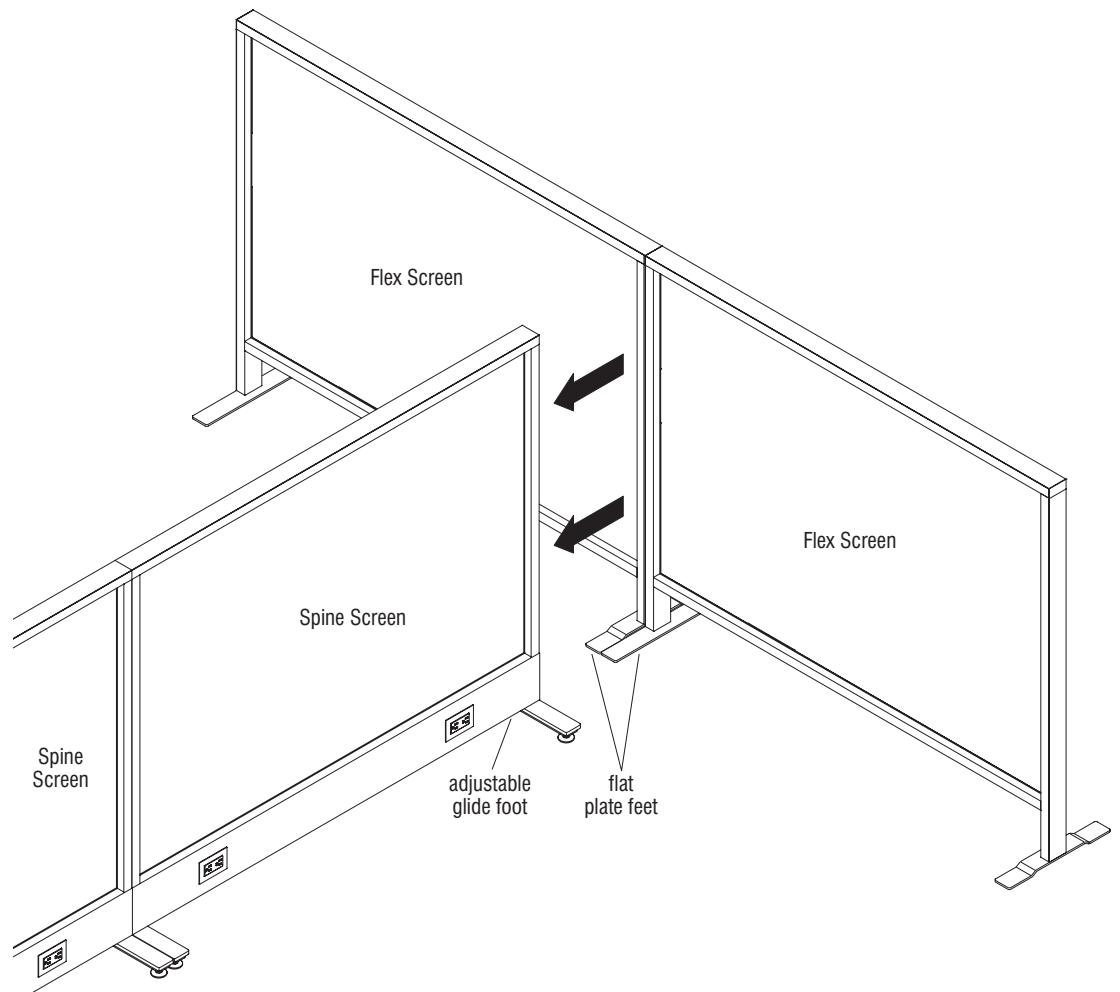
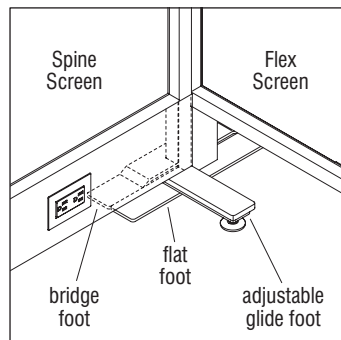
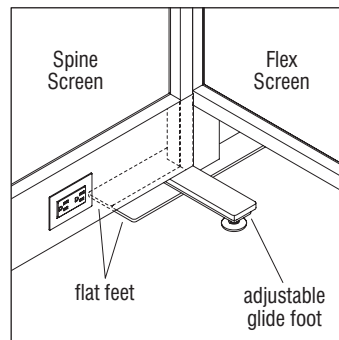

Figure 5 - Spine & Flex Screen 3-Way Intersection

1. With the Spine Screen in its final location, one at a time, carefully lift and arrange the Flex Screen feet under the perpendicular Spine Screen foot per the space-planning layout (Figure 5).
2. With both in-line Flex Screen feet under the perpendicular Spine foot, carefully place the two in-line Flex Screens against each other (Figure 5).



Detail J - Spine & Flex Screen 3-Way Intersection (adjustable glide foot over flat and bridge foot)



Detail K - Spine & Flex Screen 3-Way Intersection (adjustable glide foot over flat feet)

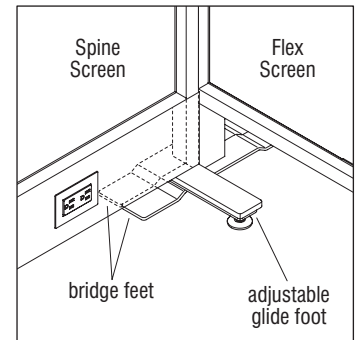

Detail L - Spine & Flex Screen 3-Way Intersection (adjustable glide foot over bridge feet)



Assemble units as described herein only. To do otherwise may result in instability. All screws, nuts and bolts must be tightened securely and must be checked periodically after assembly. Failure to assemble properly, or to secure parts may result in assembly failure and personal injury.

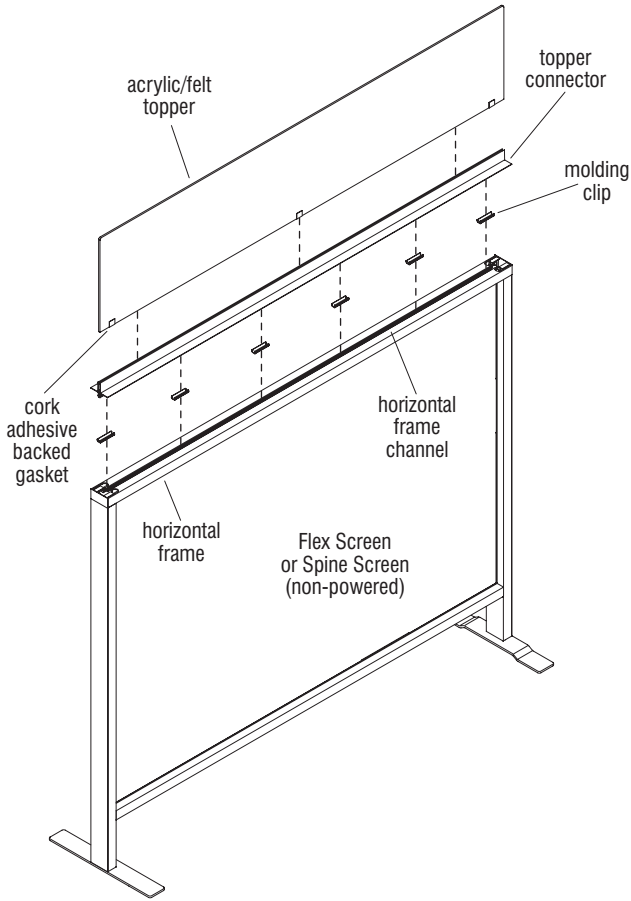

Figure 1

Topper Kit Installation

Note: Flex screens ship assembled with flat aluminum top caps installed except when topper kits are specified.

1. On the rib side of the topper connector, space molding clips evenly apart and press them onto the ribs of the connector as illustrated (Figure 1).
2. Position the topper connector with molding clips up on top of the horizontal frame channel. Using a firm hand, press the topper connector down at the molding clip locations to snap molding clips into the horizontal frame channel (Figure 1).

Note: Cork adhesive backed gasket is wrapped around the bottom at the end, and middle of acrylic toppers at the plant. Do not remove gasket as it is required for installation of the acrylic topper to the connector.

3. Set and center the acrylic or felt topper into the top opening on the topper connector and press down securely (Figure 1).



Assemble units as described herein only. To do otherwise may result in instability. All screws, nuts and bolts must be tightened securely and must be checked periodically after assembly. Failure to assemble properly, or to secure parts may result in assembly failure and personal injury.

Slide Panel Installation

1. At the underside of each horizontal frame are two horizontal frame channels separated by the screen core. Determine the location the slide panel will mount to the frame, per the space-planning layout (Figure 1).
2. Locate the horizontal frame access holes at each end of the horizontal frame channel. Insert the nylon glide through one of the access holes and slide panel towards the center of the screen until the second glide can be inserted through the same access hole (Figures 1 & 2, Details A, B, C & D).

Note: The slide panel has a writable magnetic surface on one side and a tack board on the other side. Depending on which nylon glide you insert first will determine which slide panel face is facing out.

3. Two slide panel stoppers are included with each slide panel kit. The stoppers can be used to prevent the slide panel from accidentally falling out of the access holes. To install the stoppers insert them into the access hole and slide them toward the center of the panel slightly and tighten the screw to hold in place (Detail D).

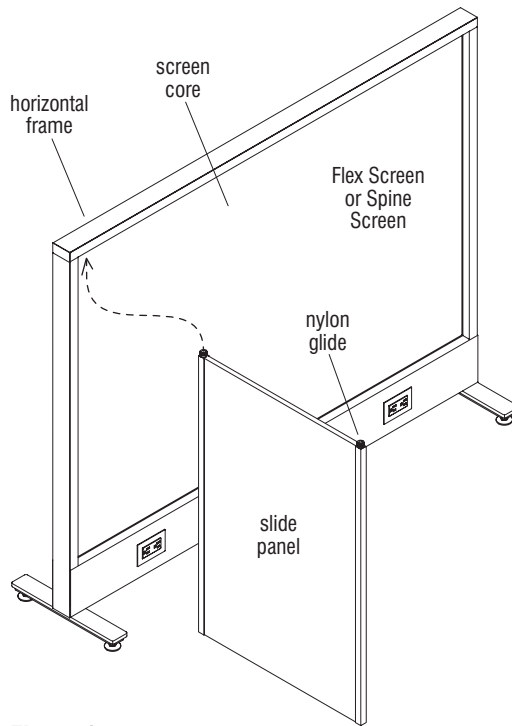

Figure 1

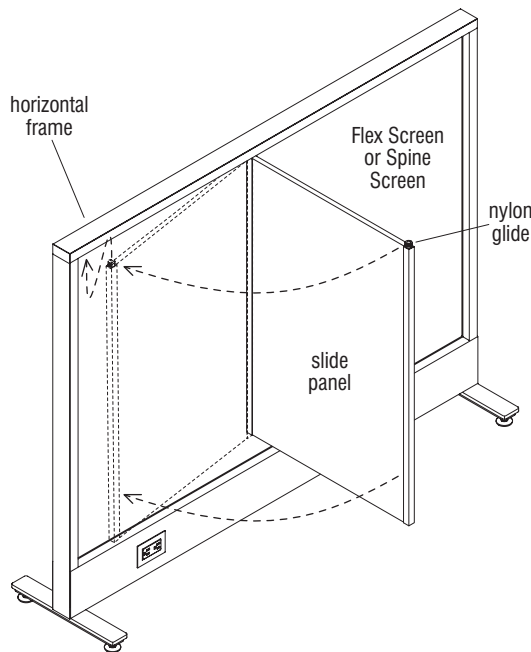
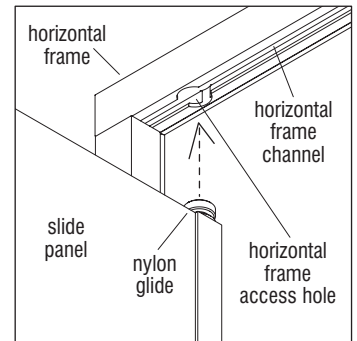
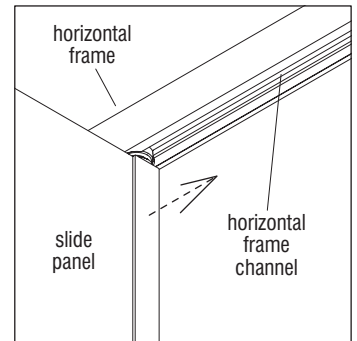

Figure 2



Detail A



Detail B

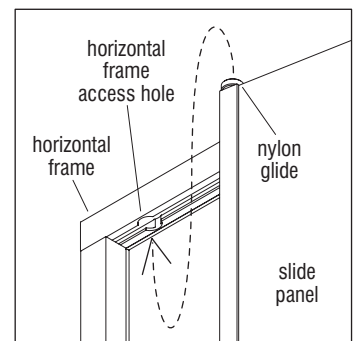

Detail C

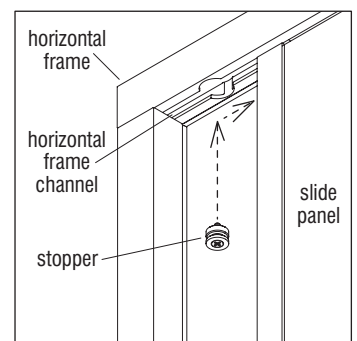

Detail D



Assemble units as described herein only. To do otherwise may result in instability. All screws, nuts and bolts must be tightened securely and must be checked periodically after assembly. Failure to assemble properly, or to secure parts may result in assembly failure and personal injury.

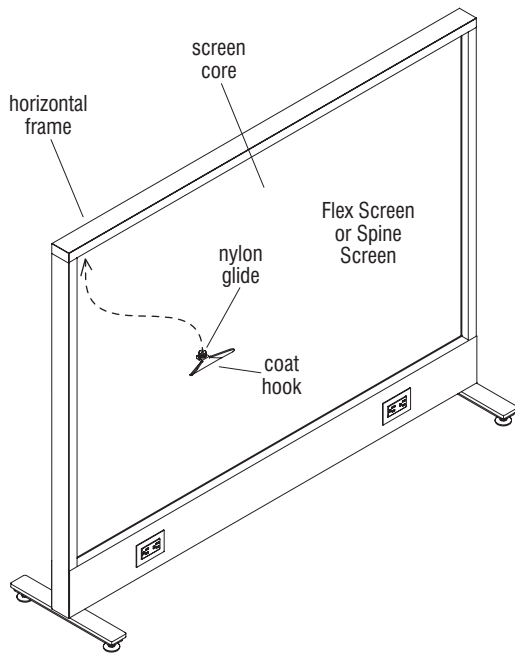

Figure 3

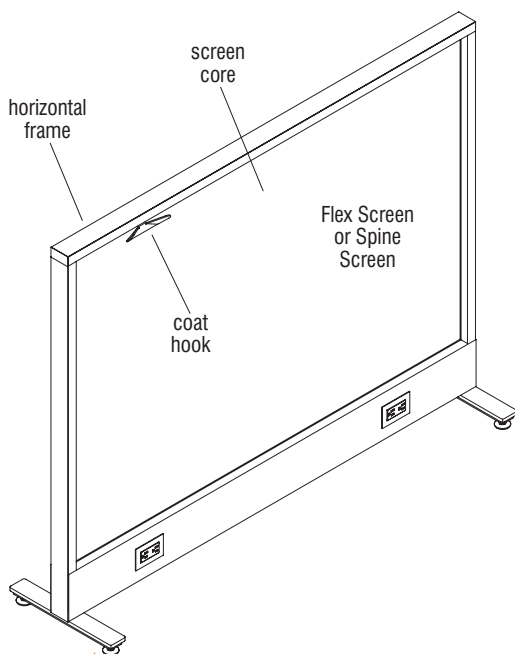
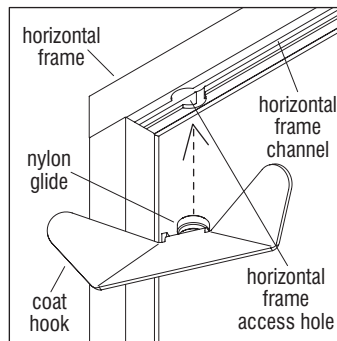
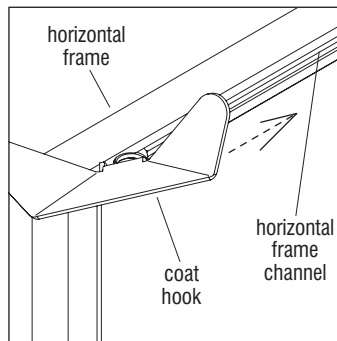

Figure 4



Detail E



Detail F

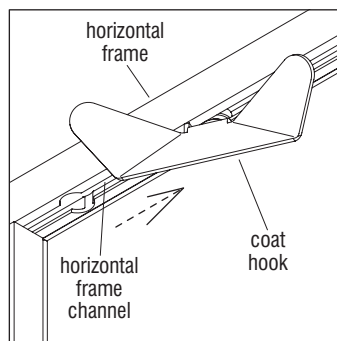

Detail G

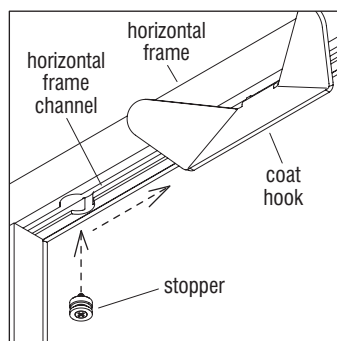

Detail H

Coat Hook Installation

1. At the underside of each horizontal frame are two horizontal frame channels separated by the screen core. Determine the location the coat hook will mount to the frame, per the space-planning layout (Figure 3).
2. Locate the horizontal frame access holes at each end of the horizontal frame channel. Insert the nylon glide through one of the access holes and slide the coat hook towards the center of the screen. Tighten the screw on the underside of the nylon glide to hold the coat hook in place (Figures 3 & 4, Details E, F & G).
3. Two coat hook stoppers are included with each coat hook kit. The stoppers can be used to prevent the coat hook from accidentally falling out of the access holes. To install the stopper insert it into the access hole and slide it just past the access hole and tighten the screw to hold it in place. If it is desired that the coat hook be constrained to one location, a stopper may be installed at each side of the coat hook, at the hook's desired location (Detail H).

KI
1330 Bellevue Street
P.O. Box 8100
Green Bay, Wisconsin 54308-8100
1-800-424-2432
www.ki.com

KI is a registered trademark
of Krueger International, Inc.

© 2019 Krueger International, Inc.
All Rights Reserved
Code KI-AI-000036R1/KI/PDF/0719

