

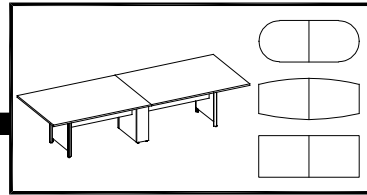

Assembly Instructions

Orenda™ Casegoods

Conference Table Aluminum Frame Base - 144"



AKLRA
AKLAA
AKLAB

SUP-SURF-TOP	QD-B-M6X12Q	FER 6	FER-PLAQUE	VIS7/8X10TRQ	QD-B-DU640	QN000001	QD-CAP-0D0
16	32	8	4	64	4	4	8

Do not turn over table using the laminate bases. Insert a piece of packaging under surface to facilitate handling.

CAUTION

Floor

1. Lay table surface and end panels upside down on soft surface to protect. Insert the 12 shoulder screws into the top (see diagram). Insert the 8 glides leaving 1/4 inch of adjustment into end panels and laminate base.

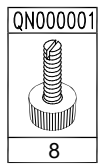

Supplied with laminate bases (4x)

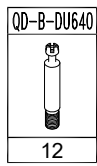
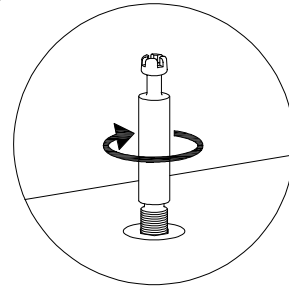
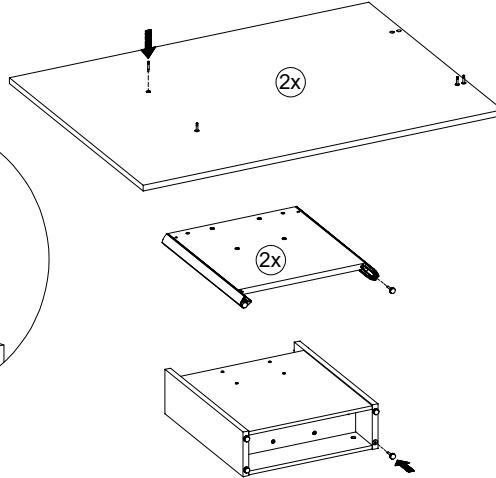
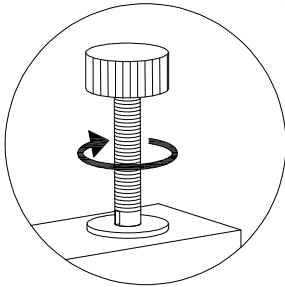

Supplied with laminate bases (8x)

2. Place bases ① ② in place then tighten all camlocks (see diagram). Place adhesive cover over visible hardware (see diagram). Place conference table tops and install splice plates (see diagram).

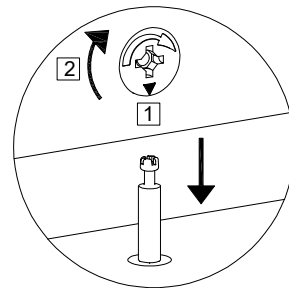
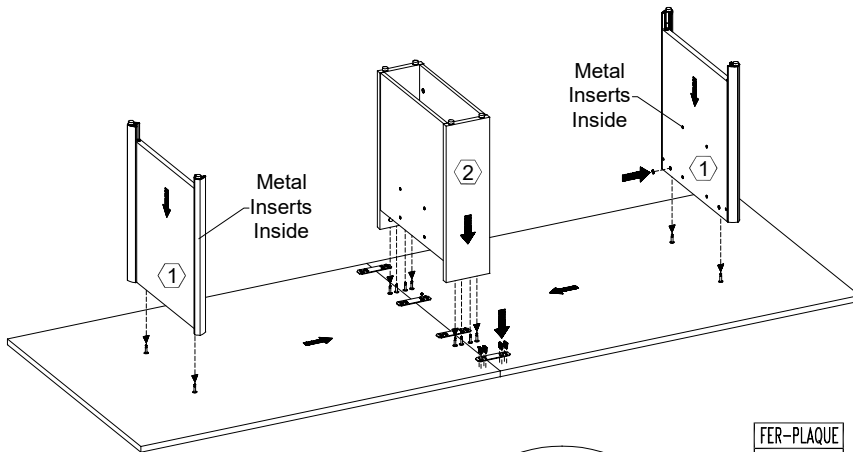

① Align arrow orientation to insert part

② Lock

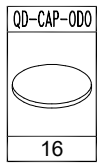
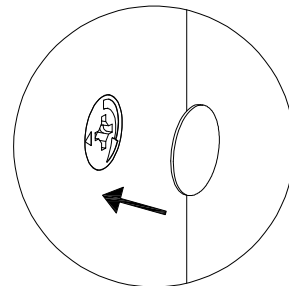

Supplied with laminate bases (8x)

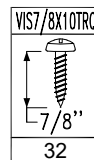
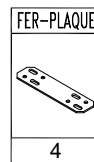
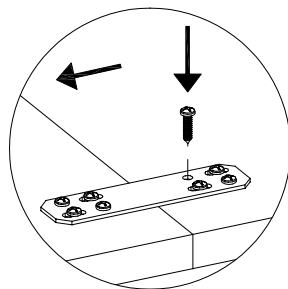



Assembly Instructions

Orenda™ Casegoods

Conference Table Aluminum Frame Base - 144"

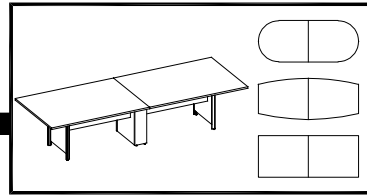

AKLRA
AKLAA
AKLAB

3. Lay laminate panels (2) surface upside down on soft surface to protect. Install all angle brackets onto the panels (see diagram).

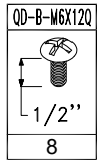
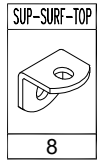
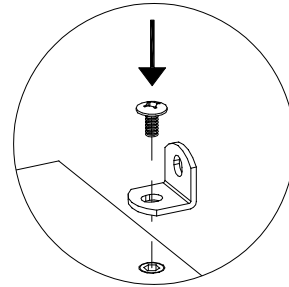
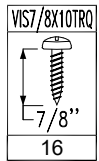
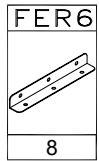
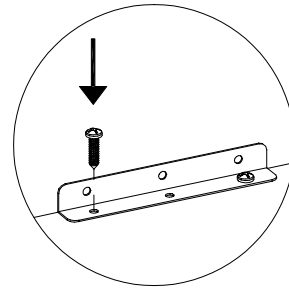
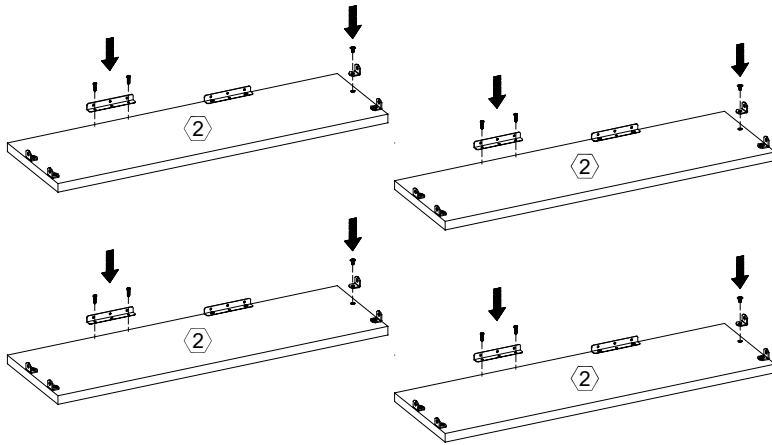

4. Place laminate panels (2) in place then install angle brackets (see diagram).

