

Tributaire Training Tables - Fixed-Height

Tributaire Training Tables - Fixed-Height Overview	?
--	---

Fixed-Height Nesting-Top Base Tables

Fixed-Height Nesting-Top Leg Assembly (Leg Kit Item #TJFN24).....	4
Caster Installation	4
Telescopic Glide Installation.....	4
Stringer Installation.....	5
Nesting Support Assembly Installation.....	6

Fixed-Height Fixed-Top Base Tables

Fixed-Height Fixed-Top Leg Assembly (Leg Kit Item #TJFF24)	9
Caster Installation	9
Glide Installation.....	9
Stringer Installation.....	10
Fixed-Top Table Support Assembly Installation.....	11

Power Modules

Power Module Overview	12
Dean In-Surface Power Module Installation	12
Dean Undersurface Power Module Installation.....	13
Dubbel Undersurface Power Module Installation	14
Nacre In-Surface Power Module Installation	15
Node In-Surface Power Module Installation.....	16
Snap-In RPT Module Installation	17

Grommets

Grommet Overview.....	18
Dean & Nacre Grommet Installation	18
Node Grommet Installation	18

Wire Management

Wire Management Overview.....	19
Wire Trough Installation.....	19
Velcro Wire Manager Installation	19

Ganging

Ganging Tables Overview	20
Peg Installation	20
Hook Installation.....	21
Ganging Tables	21

Electrical Overview

Pattern Electrical System Installation.....	23
Pattern Power Infeed Kit Assembly.....	23
Pattern Power Distribution Block Placement	25
Internal Pattern Power Jumper Assembly	26
Pattern Table-to-Table Power Jumper Kit Assembly	27

Wire Management (cont.)

Wire Management Overview.....	28
Wire Management using Velcro Wire Managers	28
Vertical Wire Manager Installation.....	29
Strain Relief Installation	30

Modesty Panel

Modesty Panels Overview	31
Polyester Felt Modesty Panel Installation.....	31
Laminate Modesty Panel Installation.....	32

Connections to Power Source

Connections to Power Source Overview.....	33
Connections to Power Source - Pattern Electrical System.....	33
Connections to Power Source - Power Modules with 3-Prong Plug	34

Pattern Quick-Release Tool

Pattern Quick-Release Tool	35
----------------------------------	----

SAVE THESE INSTRUCTIONS

IMPORTANT SAFETY INSTRUCTIONS

When using an electrical furnishing, basic precautions should always be followed, including the following:

Read all instructions before using (this furnishing).

DANGER: To reduce the risk of electric shock:

1. Always unplug this furnishing from the outlet before cleaning or servicing.

WARNING: To reduce the risk of burns, fire, electric shock, or injury to persons:

1. Unplug from outlet before putting on or taking parts off parts.
2. Close supervision is necessary when this furnishing is used by, or near children, invalids, or disabled persons.
3. Use this furnishing only for its intended use as described in these instructions. Do not use attachments not recommended by the manufacturer.
4. Do not use outdoors.
5. **WARNING:** Risk of Electric Shock - Connect this furnishing to a properly grounded outlet only. See Grounding Instructions.
6. **WARNING:** Risk of Electric Shock, Fire, and Injury - Review instructions to confirm all critical components are installed and function safely.

Pattern Electrical System

Electrical Rating: 120V 15 A

WARNING: Risk of Injury - Maximum Load 4.7 lb per inch width.

Power Modules with 3-Prong Plug

Electrical Rating: 120V 15 A

WARNING: Risk of Injury - Maximum Load 4.7 lb per inch width.



Assemble units as described herein only. To do otherwise may result in instability. All screws, nuts and bolts must be tightened securely and must be checked periodically after assembly. Failure to assemble properly, or to secure parts may result in assembly failure and personal injury.

Tributaire Training Tables - Fixed-Height Overview

Note: The beginning of this instruction is divided into two separate sections, each explaining how to assemble a specific fixed-height Tributaire training base type. Reference the following sections below based on the unit being assembled: Go to page 4 for fixed-height nesting-top base tables, or page 9 for fixed-height fixed-top base tables.

Fixed-Height Nesting-Top Leg Assembly (Leg Kit Item #TJFN24)

1. Carefully remove contents from shipping packing and identify parts and hardware supplied. **DO NOT cut zip-ties around the nesting-table support assembly until instructed to at a later step (Page 6, Detail E).**

Note: The two fixed-height nesting-top legs, when assembled together with the stringer between them are designed to have a smaller gap between the back feet, and have a larger gap between the front feet, which must be oriented to the front, "user side" of the table when the bases are assembled to the tabletop.

2. Carefully stand the two fixed-height nesting-top legs to the upright position with stringer attachment brackets facing each other as illustrated. Orient the legs so the stringer attachment brackets on each leg post are inline to each other, then identify the side of the leg pair that has a larger gap between the feet. The side with the larger gap is the user side and eventually will be placed at the user side of the tabletop (Figure 1 & Detail A).

3. If the table being assembled is a caster leg unit, proceed to "Caster Installation" instructions on this page, otherwise proceed to "Telescopic Glide Installation" instructions on this page.

Caster Installation

Note: Casters are designed as locking, and non-locking. Each type must be installed to the appropriate side of a table leg, as it corresponds to either the user, or non-user side of the table. Take care and follow directions below when positioning legs for caster assembly. If casters are not installed to the proper locations, users will not be able to properly access the locks on the casters from the user side of the table, and disassembly and reassembly will be required.

4. Locate the locking and non-locking casters. Locking casters are to be installed to the front, user side of each leg, and non-locking casters are to be installed to the rear of each leg. Insert the stem of one locking and one non-locking caster into the caster mounting holes at the underside of each foot. Press in casters fully until each is snug to the bottom of the foot (Figure 1).

5. Proceed to "Stringer Installation" instructions on the next page.

Telescopic Glide Installation

6. Insert the stem of two telescopic glides into the mounting holes at the underside of each foot. Press in fully until each glide is snug to the bottom of the foot (Figure 1).

7. Proceed to "Stringer Installation" instructions on the next page.

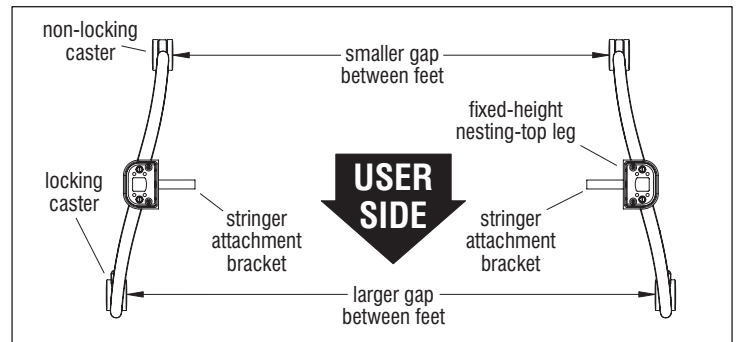

Detail A - (top view)

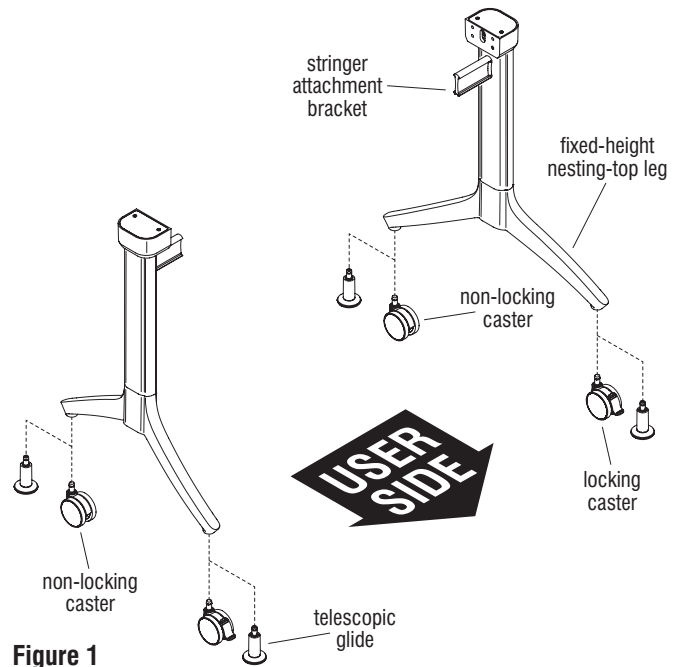
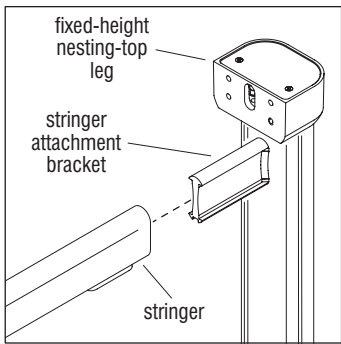

Figure 1



Assemble units as described herein only. To do otherwise may result in instability. All screws, nuts and bolts must be tightened securely and must be checked periodically after assembly. Failure to assemble properly, or to secure parts may result in assembly failure and personal injury.



Detail B

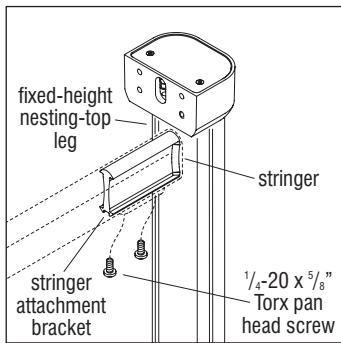

Detail C

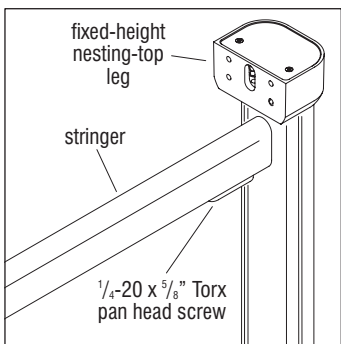

Detail D

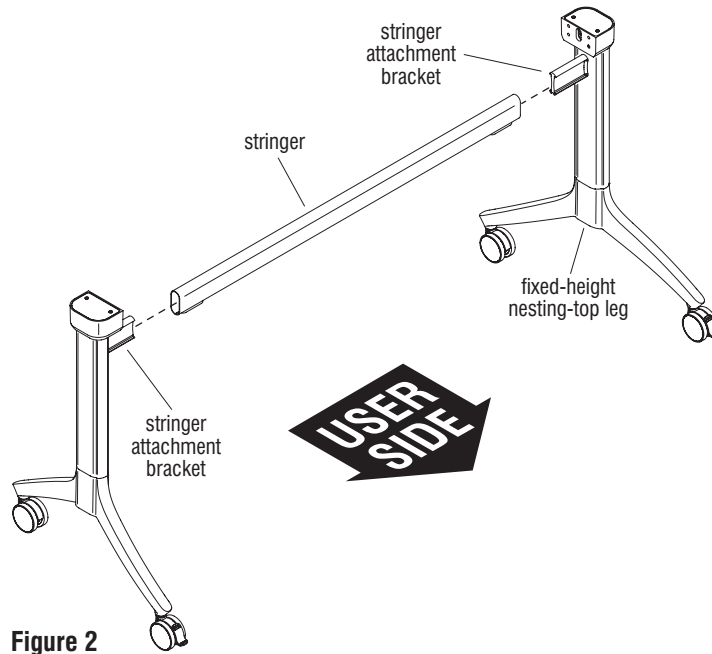

Figure 2

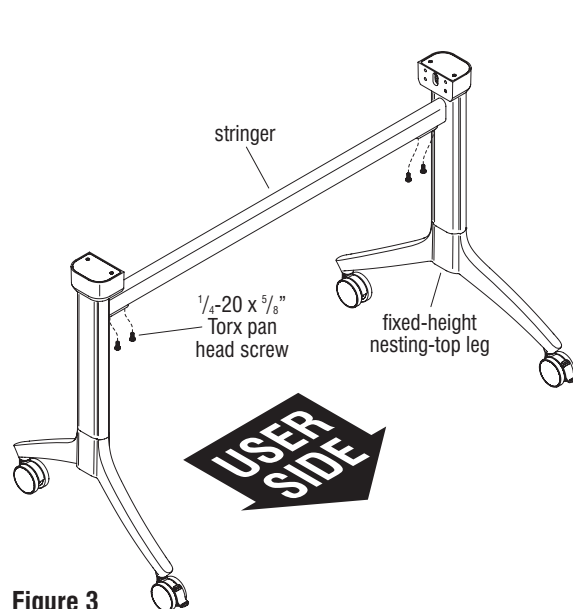

Figure 3

Stringer Installation

8. Orient the stringer so the side with two mounting holes on each end is on the underside of the stringer (Figure 2).
9. One leg at a time, insert the stringer attachment bracket into an available open end of the stringer, making sure the mounting holes are on the bottom of each end of the stringer. If the stringer is not positioned correctly for installation, disassembly and reassembly will be required (Figure 2 & Detail B).
10. From underneath, one side at a time, align the stringer mounting holes with the stringer attachment bracket mounting holes, and secure using two 1/4-20 x 5/8" Torx screws on the underside hole locations. Repeat the step above to secure the stringer to the opposite leg's stringer attachment bracket (Figure 3 & Details C & D).



Assemble units as described herein only. To do otherwise may result in instability. All screws, nuts and bolts must be tightened securely and must be checked periodically after assembly. Failure to assemble properly, or to secure parts may result in assembly failure and personal injury.

Nesting Support Assembly Installation

11. Carefully place the nesting support assembly on a soft, protective surface (Figure 4).

WARNING: The nesting support assembly consists of two spring-loaded mechanisms, one on each end of an actuating rod. Each spring-loaded mechanism is latched, and for safety is secured in the closed position with a zip-tie to prevent the mechanisms from flipping open if the tabletop lock paddles are accidentally engaged during shipment. Care must be taken when removing the zip-ties. **Assure that both nesting mechanisms are pressed closed and latched, and do not actuate the tabletop lock paddles before cutting zip-ties.**

12. While facing the user side of the nesting support assembly, one side at a time, press down firmly on the top of the spring-loaded mechanism on the user side of the plate, then cut the zip-tie with a wire cutter and pull it out. While holding the mechanism down firmly, gently lift on the tabletop lock paddle, and release the holding pressure to open that side of the mechanism. Repeat the process for carefully cutting and removing the zip-tie, then actuating the tabletop lock paddle to open the mechanism at the other end of the support assembly. Take care to not actuate the tabletop lock paddles while cutting, which may release the spring-loaded mechanism quickly and cause personal injury (Figure 4 & Details E & F).

13. Position the opened nesting support mechanism above the two mounting heads, making sure the opening is facing the user side of the table assembly as illustrated. With the assistance of a second person, have one person carefully lower the opened spring-loaded mechanisms in between the two mounting heads, aligning the four lower hinge plate mounting holes with the four side mounting head

mounting holes, while the second person follows step 14 below (Figure 5 & Detail G).

14. With the mounting head and lower hinge plate mounting holes aligned, from inside the lower hinge plate, have the second person secure each lower hinge plate to the side of the mounting head using the top

two holes and two 1/4"-20 x 3/4" Phillips flat head screws. Using drill extensions longer than 7" with a Phillips tip at the side of the lower hinge plate access holes, finish securing the lower hinge plate to the mounting head using two 1/4"-20 x 3/4" Phillips flat head screws in the two bottom holes (Detail H).

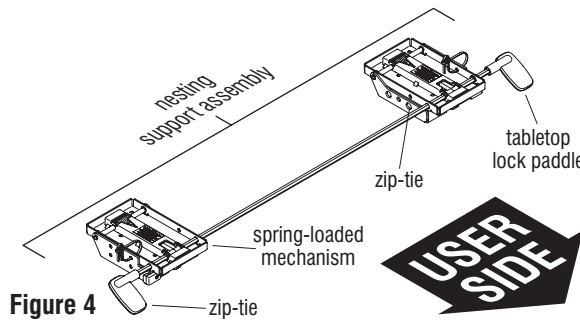

Figure 4

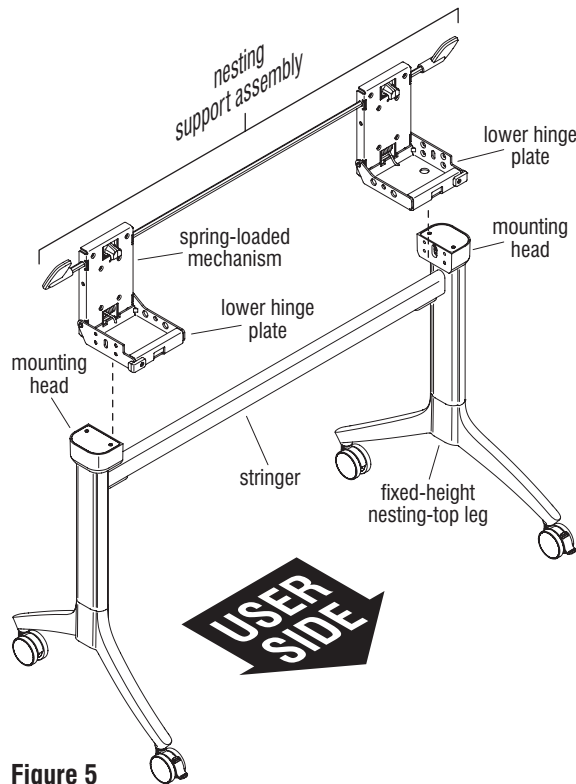
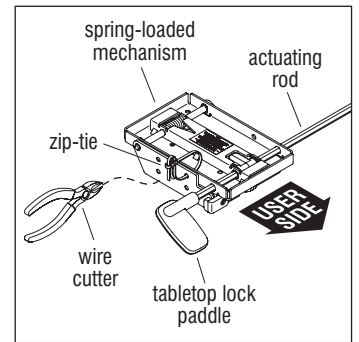
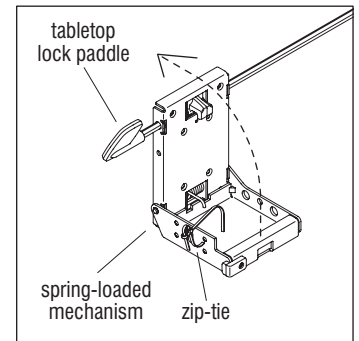

Figure 5



Detail E



Detail F

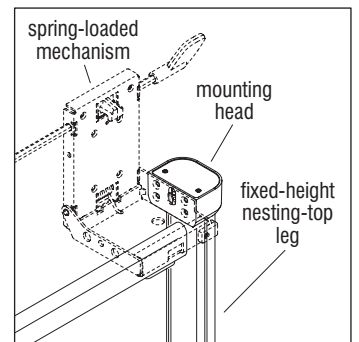

Detail G

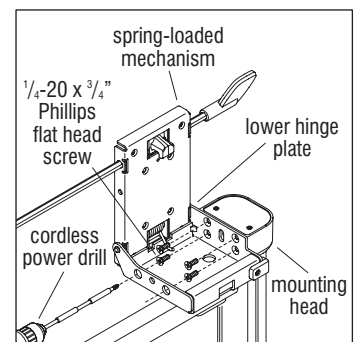

Detail H



Assemble units as described herein only. To do otherwise may result in instability. All screws, nuts and bolts must be tightened securely and must be checked periodically after assembly. Failure to assemble properly, or to secure parts may result in assembly failure and personal injury.

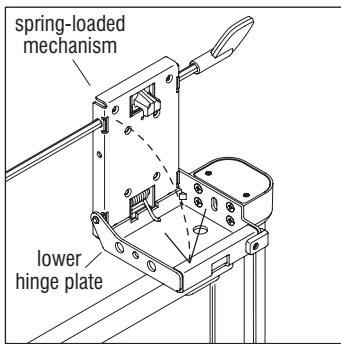

Detail I

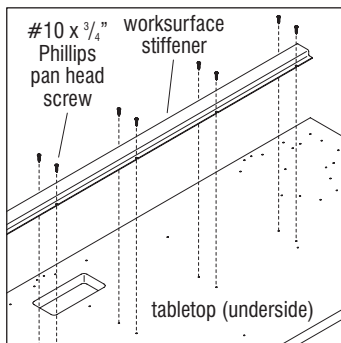

Detail J

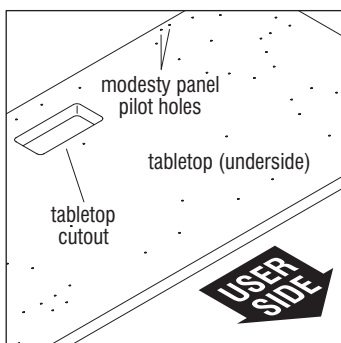

Detail K

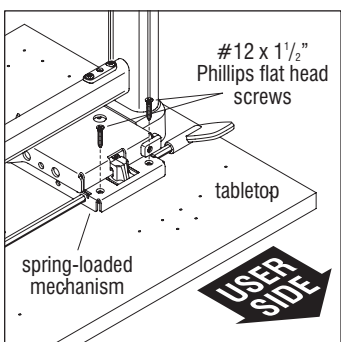

Detail L

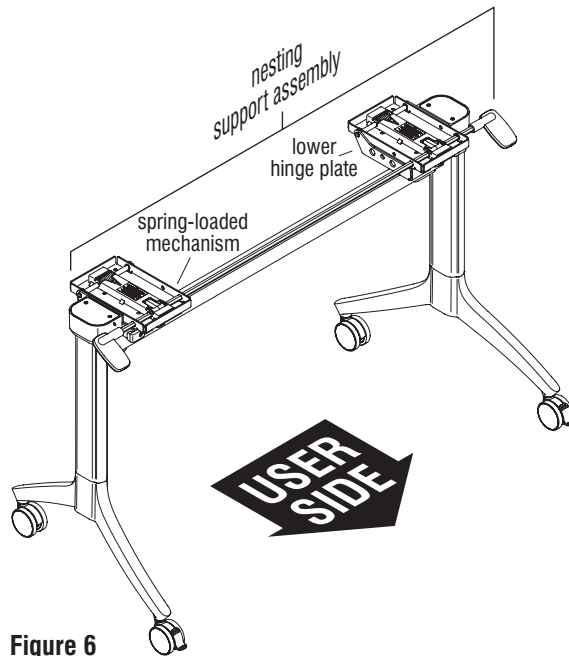

Figure 6

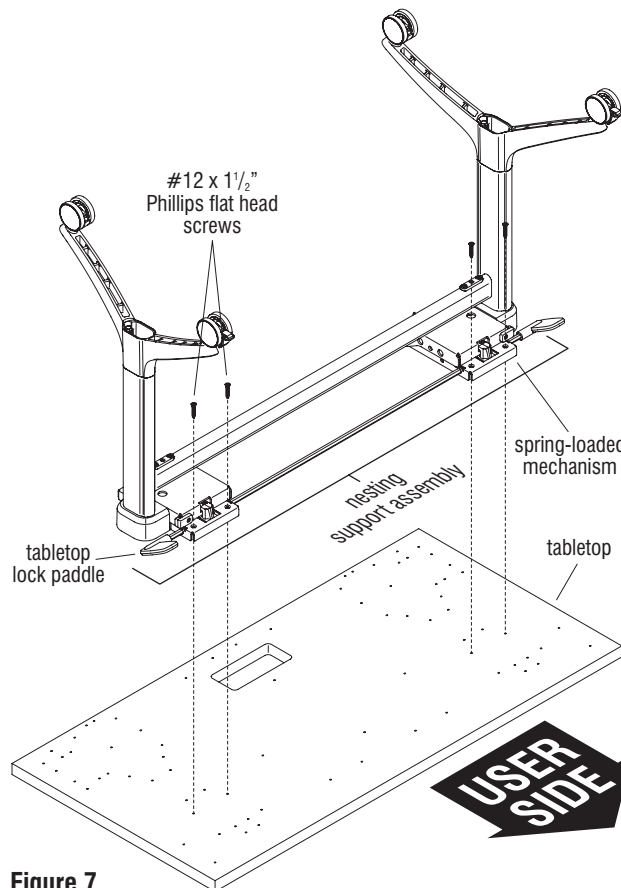

Figure 7

15. Carefully close and latch both spring-loaded mechanisms down onto the lower hinge plates (Figure 6 & Detail I).
16. Carefully place the tabletop upside down on a soft, protective surface (Figure 7).

Note: Worksurface stiffeners are only used on tables that are 72" wide. If the table is 72" wide and 36" deep, two stiffeners are required.
17. If a worksurface stiffener is provided, position it onto the center of the tabletop underside, aligning the stiffener mounting holes with the pre-drilled holes in the table. Secure the stiffener to the tabletop using #10 x 3/4" Phillips pan head screw through all stiffener mounting holes provided (Detail J).
18. Take note that the "non-user side" of the tabletop has a pilot hole pattern for the modesty panel near the back edge, at each corner. Carefully position the nesting support assembly onto the tabletop with the tabletop lock paddles and wider spread of the legs oriented to be facing the user side of the table, as illustrated (Figure 7 & Detail K).

WARNING: For the next step, when securing the leg attachment brackets to the lower hinge plates, **DO NOT** touch the tabletop lock paddles as they may accidentally engage and cause the spring-loaded mechanisms to flip up causing personal injury.
19. Align the two mounting holes on the front of each spring-loaded mechanism of the nesting support assembly to the corresponding pre-drilled holes at the underside of the tabletop, then secure into each pre-drilled hole a #12 x 1 1/2" Phillips flat head screw. Do not over-tighten (Figure 7 & Detail L).

Tributaire™ Collection - Fixed-Height Nesting-Top Base Training Tables
 Assembly Instructions



Assemble units as described herein only. To do otherwise may result in instability. All screws, nuts and bolts must be tightened securely and must be checked periodically after assembly. Failure to assemble properly, or to secure parts may result in assembly failure and personal injury.

Nesting Support Assembly Installation (cont.)

20. Move to the non-user side and align the two mounting holes on the back of each spring-loaded mechanism of the nesting support assembly to the corresponding pre-drilled holes at the underside of the tabletop, then secure into each pre-drilled hole a #12 x 1½" Phillips flat head screw. Do not over-tighten (Figure 8 & Detail M).
21. Press the tabletop lock paddles down and gently lower the fixed-height nesting-top legs down to gain access to the center group of spring-loaded mechanism mounting holes (Figure 9).
22. With the four center mounting holes on each spring-loaded mechanism of the nesting support assembly aligned with the mounting holes on the tabletop underside, secure the mechanism to the tabletop using four #12 x 1½" Phillips flat head screws per mechanism. Do not over-tighten (Figure 9 & Detail N).
23. Carefully flip up the leg assembly to close the spring-loaded mechanisms, then turn the table to the upright position.
24. If the table being assembled will receive power, proceed to "Power Module Overview" instructions on page 12. If the table being assembled does not require power, but requires a grommet, proceed to "Grommet Overview" instructions on page 18. If the table being assembled does not require power or grommets but will be ganged to another table, proceed to page 20. If the table does not require power, grommets, or to be ganged but requires a modesty panel, proceed to page 31. If the table requires none of the above, move it to the final location of use.

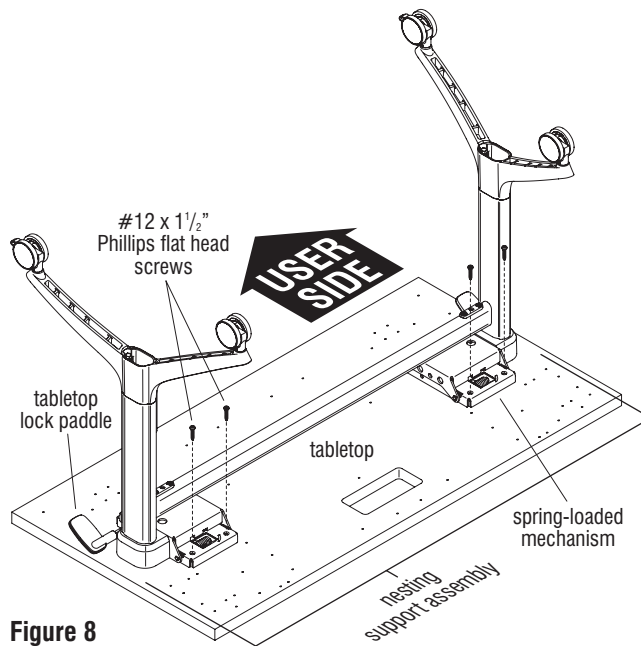
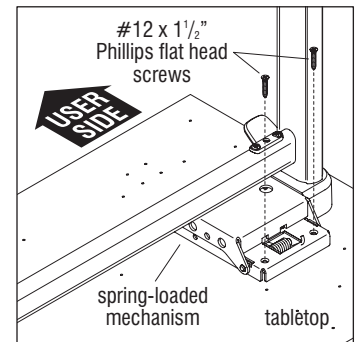
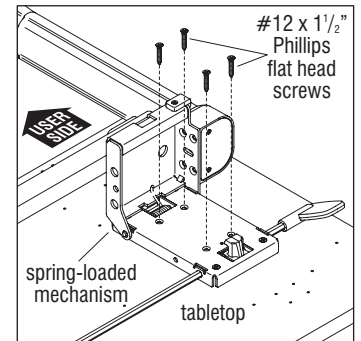

Figure 8



Detail M



Detail N

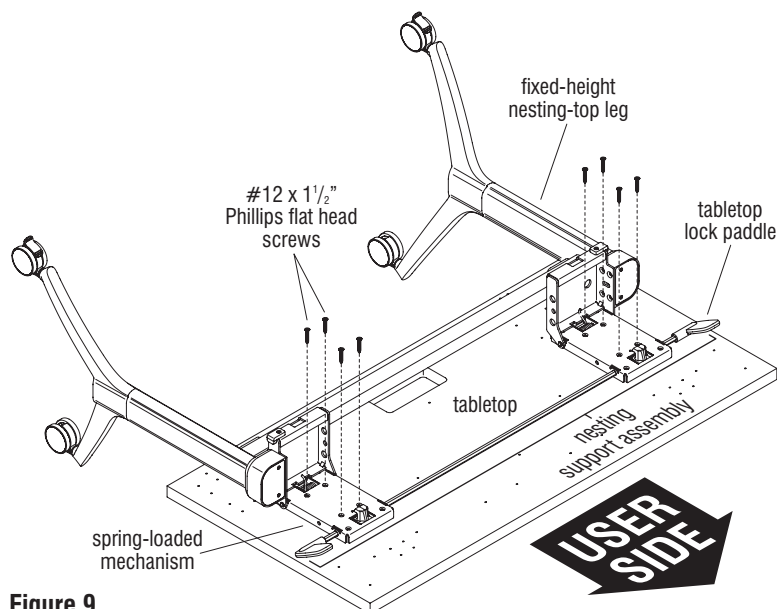
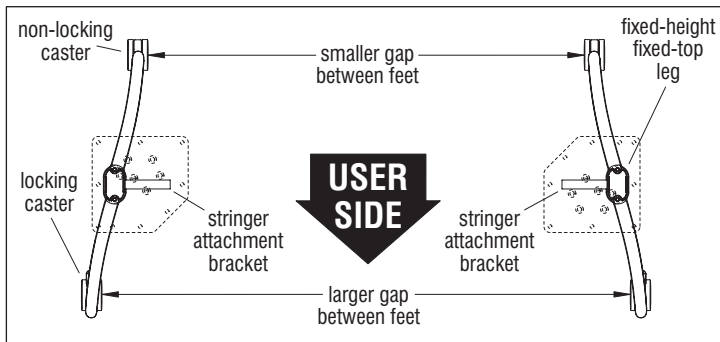

Figure 9



Assemble units as described herein only. To do otherwise may result in instability. All screws, nuts and bolts must be tightened securely and must be checked periodically after assembly. Failure to assemble properly, or to secure parts may result in assembly failure and personal injury.



Detail A - (top view)

Fixed-Height Fixed-Top Leg Assembly (Leg Kit Item #TJFF24)

1. Carefully remove contents from shipping packing and identify parts and hardware supplied.

Note: The two fixed-height fixed-top legs, when assembled together with the stringer between them are designed to have a smaller gap between the back feet, and have a larger gap between the front feet, which must be oriented to the front, "user side" of the table when the bases are assembled to the tabletop.

2. Carefully stand the two fixed-height fixed-top legs to the upright position with stringer attachment brackets facing each other as illustrated. Orient

the legs so the stringer attachment brackets on each leg post are inline to each other, then identify the side of the leg pair that has a larger gap between the feet. The side with the larger gap is the user side and eventually will be placed at the user side of the tabletop (Figure 1 & Detail A).

3. If the table being assembled is a caster leg unit, proceed to "Caster Installation" instructions on this page, otherwise proceed to "Telescopic Glide Installation" instructions on this page.

Caster Installation

Note: Casters are designed as locking, and non-locking. Each type must be installed to the appropriate side of a table leg, as it corresponds to either the user, or non-user side of the table. Take care and follow directions below when positioning legs for caster assembly. If casters are not installed to the proper locations, users will not be able to properly access the locks on the casters from the user side of the table, and disassembly and reassembly will be required.

4. Locate the locking and non-locking casters. Locking casters are to be installed to the front, user side of each leg, and non-locking casters are to be installed to the rear of each leg. Insert the stem of one locking and one non-locking caster into the caster mounting holes at the underside of each foot. Press in casters fully until each caster is snug to the bottom of the foot (Figure 1).

5. Proceed to "Stringer Installation" instructions on the next page.

Telescopic Glide Installation

6. Insert the stem of two telescopic glides into the mounting holes at the underside of each foot. Press in fully until each glide is snug to the bottom of the foot (Figure 1).

7. Proceed to "Stringer Installation" instructions on the next page.

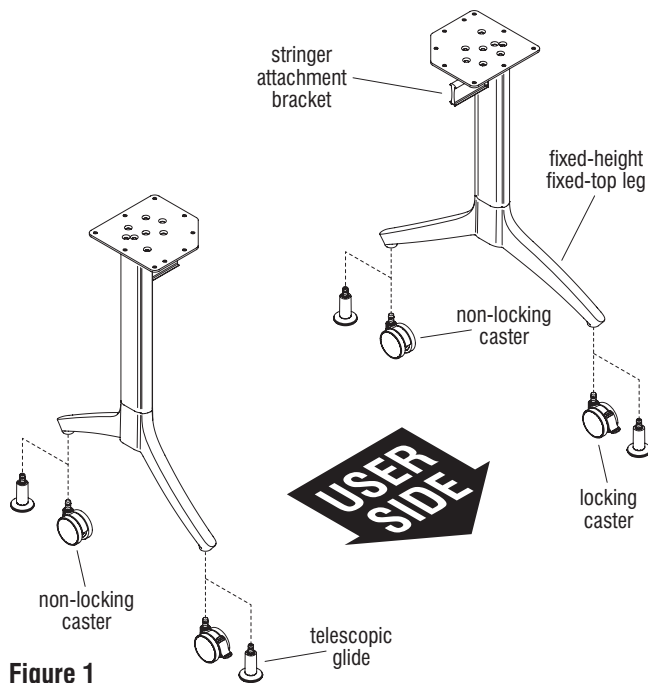

Figure 1

Tributaire™ Collection - Fixed-Height Fixed-Top Base Training Tables

Assembly Instructions



Assemble units as described herein only. To do otherwise may result in instability. All screws, nuts and bolts must be tightened securely and must be checked periodically after assembly. Failure to assemble properly, or to secure parts may result in assembly failure and personal injury.

Stringer Installation

8. Orient the stringer so the side with two mounting holes on each end is on the underside of the stringer (Figure 2).
9. One leg at a time, insert the stringer attachment bracket into an available open end of the lower stringer, making sure the mounting holes are on the bottom of each end of the stringer. If the stringer is not positioned correctly for installation, disassembly and reassembly will be required (Figure 2 & Detail B).
10. From underneath, one side at a time, align the stringer mounting holes with the stringer attachment bracket mounting holes, and secure using two $\frac{1}{4}$ -20 x $\frac{5}{8}$ " Torx screws on the underside hole locations. Repeat the step above to secure the stringer to the opposite leg's stringer attachment bracket (Figure 3 & Details C & D).

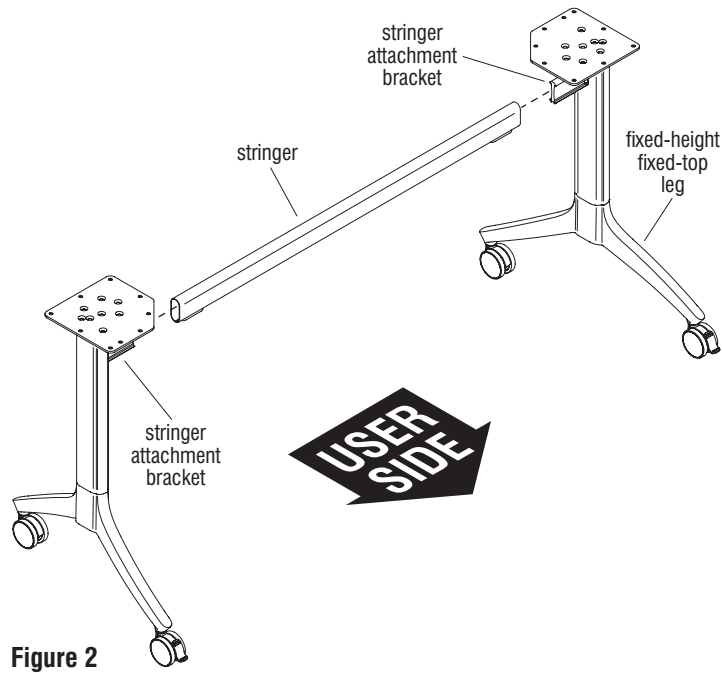
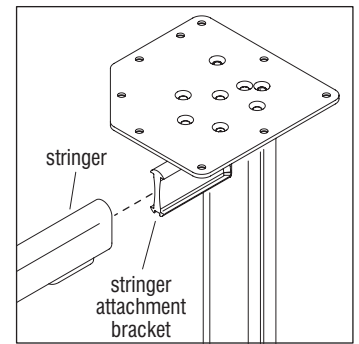
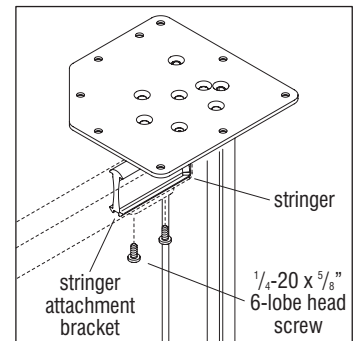

Figure 2



Detail B



Detail C

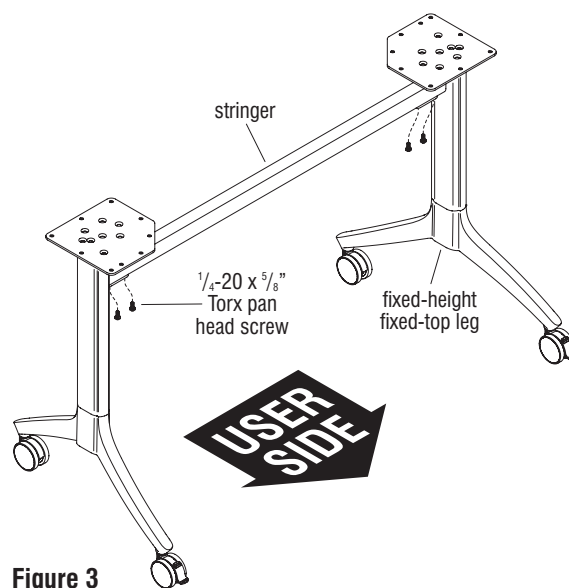
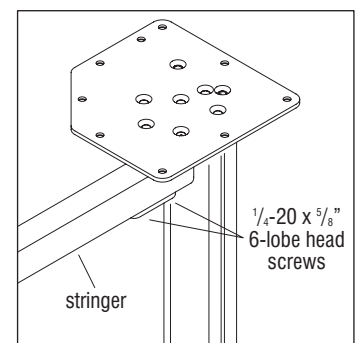

Figure 3



Detail D



Assemble units as described herein only. To do otherwise may result in instability. All screws, nuts and bolts must be tightened securely and must be checked periodically after assembly. Failure to assemble properly, or to secure parts may result in assembly failure and personal injury.

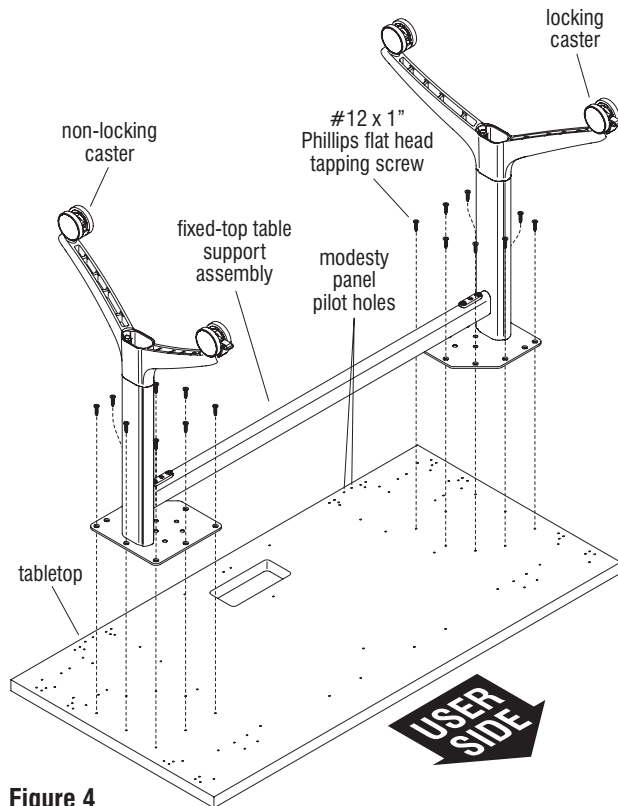

Figure 4

Fixed-Top Table Support Assembly Installation

1. Carefully place the tabletop upside down on a soft, protective surface. Take note that the “non-user side” of the tabletop has a pilot hole pattern for the modesty panel near the back edge, at each corner as illustrated (Figure 4).
2. Carefully set the fixed-height fixed-top base assembly upside down onto the tabletop, making sure the larger gap between the legs is facing the user side of the table. Align each fixed-tabletop bracket's mounting holes with the tabletop mounting holes and secure using four #12 x 1" Phillips pan head tapping screws per plate (Figure 4).
3. Carefully turn the table to the upright position.
4. If the table being assembled will receive power, proceed to “Power Module Overview” instructions on page 12. If the table being assembled does not require power, but requires a grommet, proceed to “Grommet Overview” instructions on page 18. If the table being assembled does not require power or grommets but will be ganged to another table, proceed to page 20. If the table does not require power, grommets, or to be ganged but requires a modesty panel, proceed to page 31. If the tables requires none of the above, carefully turn the table upright and move it to the final location of use.

Tributaire™ Collection - Fixed-Height Training Tables - Power Modules

Assembly Instructions



Assemble units as described herein only. To do otherwise may result in instability. All screws, nuts and bolts must be tightened securely and must be checked periodically after assembly. Failure to assemble properly, or to secure parts may result in assembly failure and personal injury.

Power Module Overview

Note: Although the figures throughout the “Power Module” instructions illustrate a fixed-height nesting-top base table, the instructions apply to all Tributaire fixed-height training tables. Your configuration may vary.

Note: If the Tributaire training table being assembled requires a power module, reference the following sections below based on the power module your table requires: Go to page 12 for Dean in-surface power modules, page 13 for Dean undersurface power modules, page 14 for Dubbel undersurface power modules, page 15 for Nacre in-surface pop-up power modules, page 16 for Node in-surface power modules or page 17 for Snap-In RPT modules.

Dean® In-Surface Power Module Installation

1. With the assembled table in the upright position, orient the Dean in-surface power module as shown and route the plug end down through the cutout in the tabletop. Press the module down firmly into the cutout (Figure 1 & Detail A).
2. At the underside of the Dean in-surface power module, at each end are two horizontal channels which the clamp bracket assemblies slide into. Position each clamp bracket so the screws are oriented away from the power module, as illustrated in Detail B. Insert a clamp bracket into the two channels on each end of the power module, sliding each in until the top bracket is completely engaged with the channel (Detail C).
3. Using the screws on the clamp bracket assembly, tighten the screws to the tabletop underside to secure the Dean-In-Surface power module in place to the tabletop (Detail C).
4. Select the appropriate data plate adapter for the phone/data jack to be used and carefully remove from injection molded tree (Detail D).

Note: Jacks are sold by separate companies and are not supplied with the module.

5. Wire the jack appropriately to the data plate and snap the data plate assembly into the module grommet opening as shown (Detail E).

Note: Depending on style of data jack used, it may be necessary to route the phone/data cord through the module grommet opening and data plate to install. Each installation may vary.

6. Proceed to “Wire Management Overview” instructions on page 19.

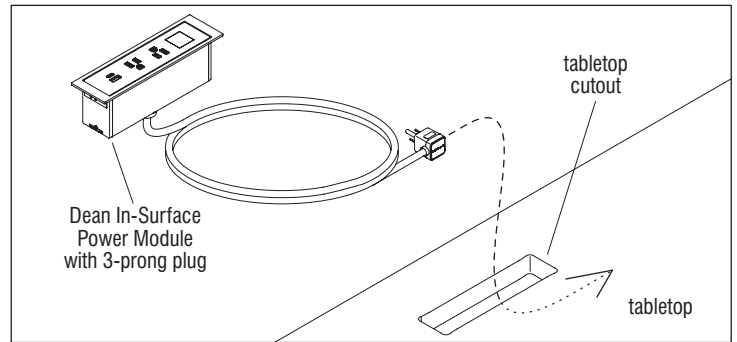

Detail A

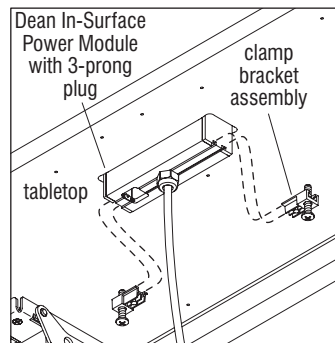

Detail B - (underside view)

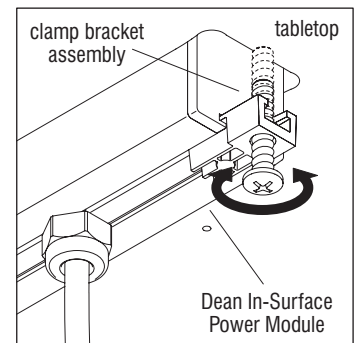

Detail C - (underside view)

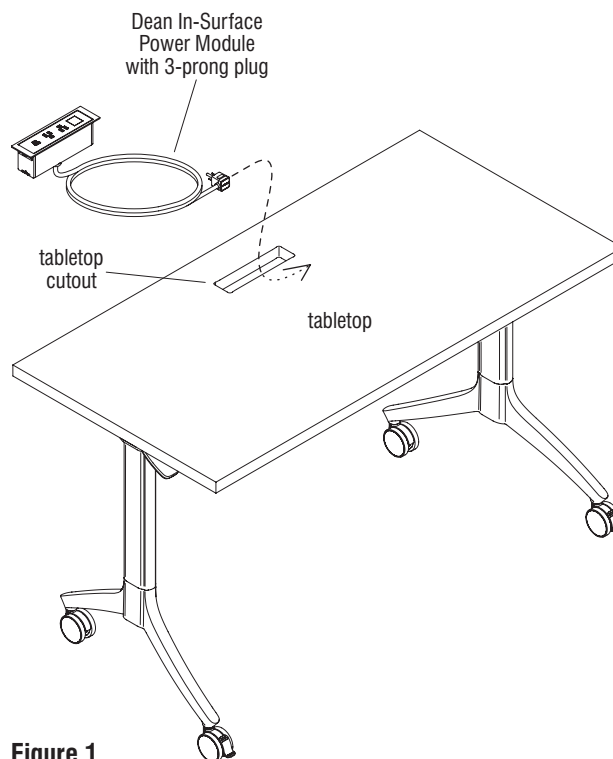
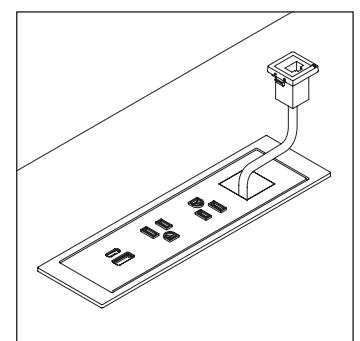

Figure 1

Data Adapter Plates	
BBB	L-Com Keystone Modular, NETCONNECT and 110 Connect Series Modular Jack, Siemon ZMAX Style, Allen Tel Versa Tap Series, Leviton Quick Port Series, Belden REVConnect, HDMI Adapter Cable.
CCC	Hubbell Nextspeed Keystone Series, ADC Truenet Series
DDD	Blank (no coupler/jack)
EEE	Ortronics Tracjack Series
FFF	Panduit Mini-Com Series
HHH	Video Monitor Jack/DB-15

Detail D



Detail E



Assemble units as described herein only. To do otherwise may result in instability. All screws, nuts and bolts must be tightened securely and must be checked periodically after assembly. Failure to assemble properly, or to secure parts may result in assembly failure and personal injury.

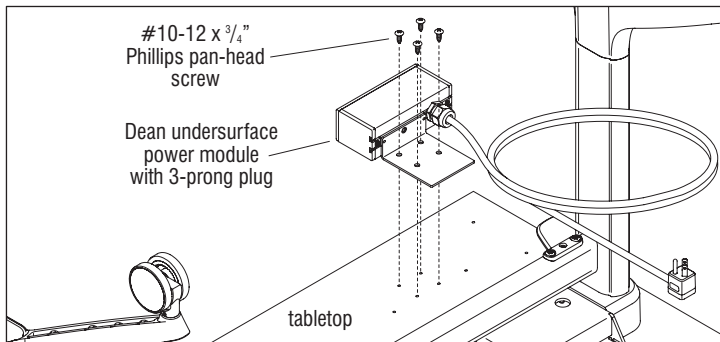

Detail F - Left or Right Aligned Dean Mounting Holes

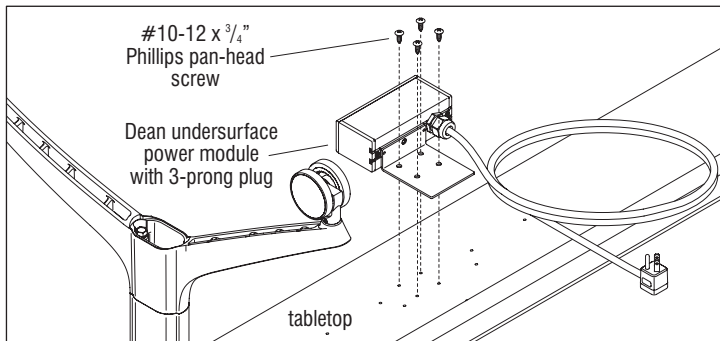

Detail G - Center Aligned Dean Mounting Holes

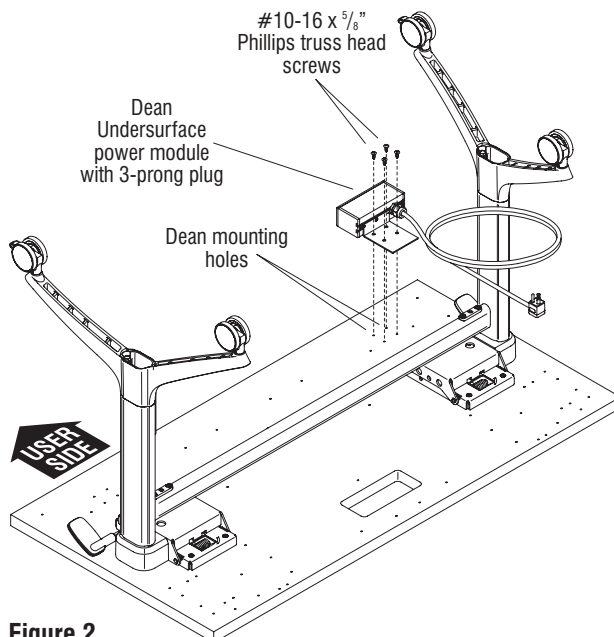

Figure 2

Dean® Undersurface Power Module Installation

1. Align the mounting holes of the Dean undersurface power module with one of the three sets of Dean pre-drilled mounting hole locations underneath the front, user side of the tabletop (Figure 2 and Detail F). Secure the Dean power module to the tabletop using two #10-12 x 3/4" Phillips pan head screws (Figure 2 & Details F & G).
2. Proceed to "Wire Management Overview" instructions on page 19.



Assemble units as described herein only. To do otherwise may result in instability. All screws, nuts and bolts must be tightened securely and must be checked periodically after assembly. Failure to assemble properly, or to secure parts may result in assembly failure and personal injury.

Dubbel Undersurface Power Module Installation

1. Align the mounting holes of the Dubbel undersurface power module with one of the two sets of Dubbel pre-drilled mounting hole locations underneath the front, user side of the tabletop, three sets of hole locations if the table is 60" or wider (Figure 3 and Details H & I). Secure the Dubbel power module to the tabletop using two #10-12 x 3/4" Phillips pan head screws (Figure 3 & Details H & I).
2. Proceed to "Wire Management Overview" instructions on page 19.

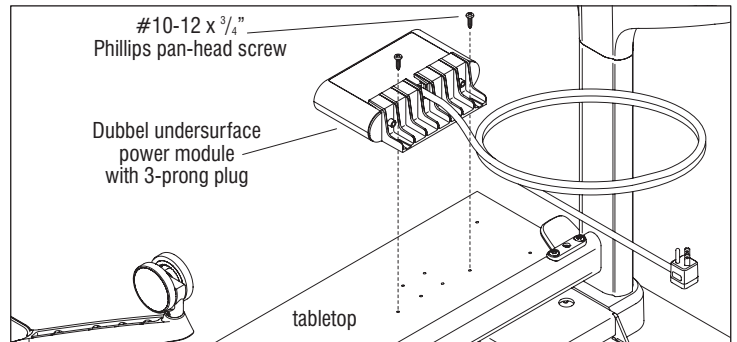

Detail H - Left or Right Aligned Dean Mounting Holes

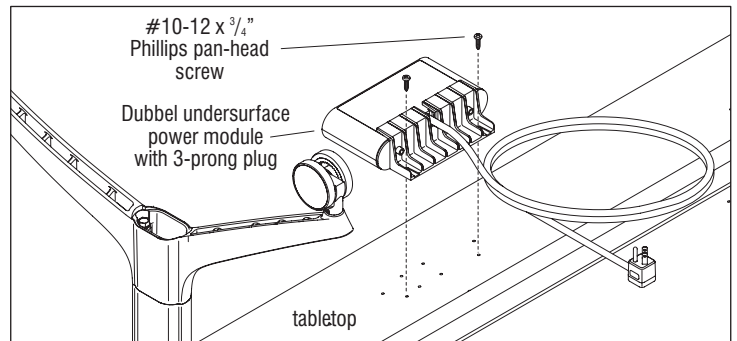

Detail I - Center Aligned Dean Mounting Holes

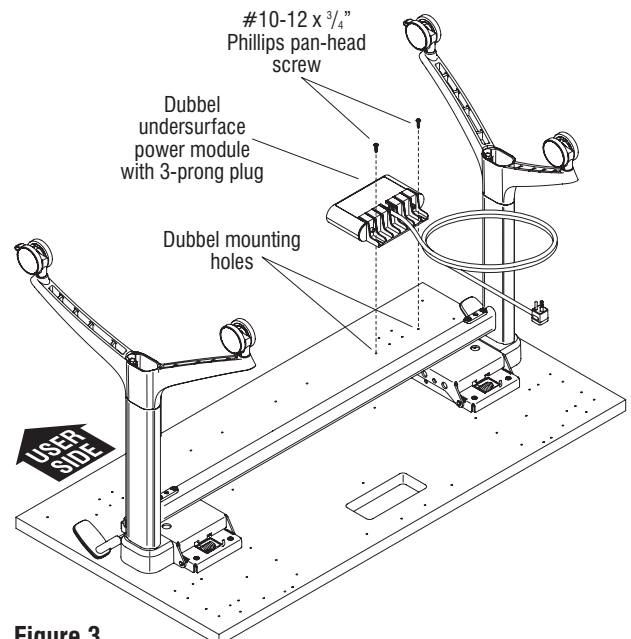
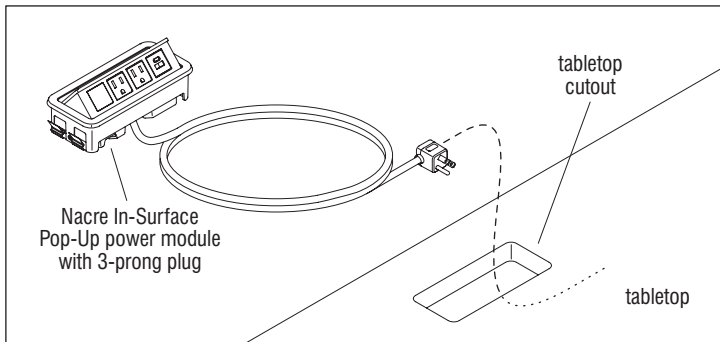

Figure 3



Assemble units as described herein only. To do otherwise may result in instability. All screws, nuts and bolts must be tightened securely and must be checked periodically after assembly. Failure to assemble properly, or to secure parts may result in assembly failure and personal injury.



Detail J

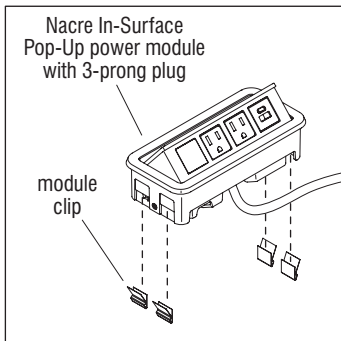

Detail K

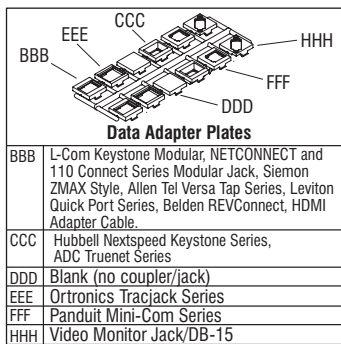

Detail L

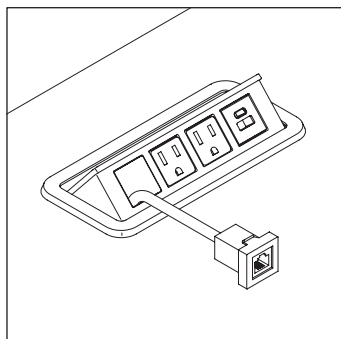

Detail M

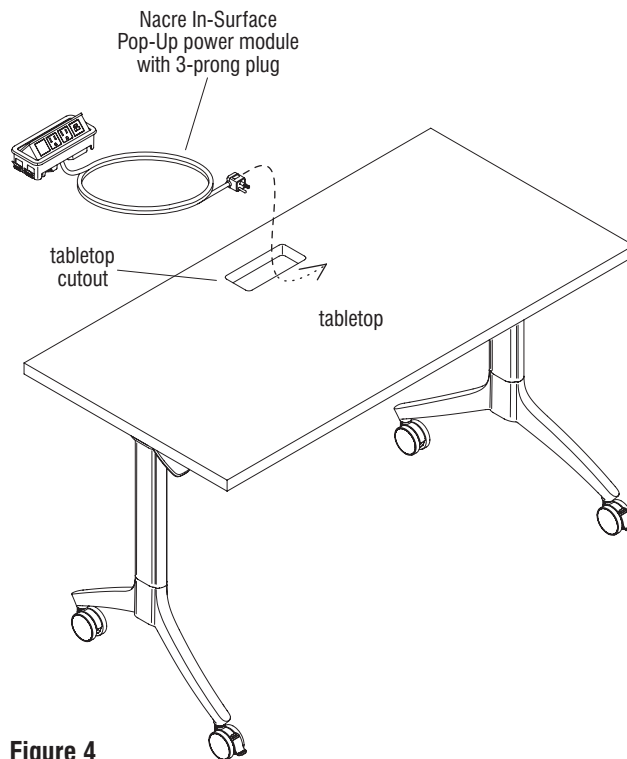

Figure 4

Nacre® In-Surface Pop-Up Power Module Installation

1. Attach four module clips, two at each end, onto the sides of the Nacre in-surface pop-up power module as illustrated (Detail K).
2. With the assembled table in the upright position, orient the Nacre in-surface pop-up power module as shown and route the plug end down through the tabletop cutout. Press the module down firmly into the cutout to secure in place, making sure the two clips on each side of the module catch under the cutout bottom edge of the tabletop (Figure 4 & Detail J).
3. Select the appropriate data adapter plate for the phone/data jack to be used and carefully remove from injection molded tree (Detail L).

Note: Jacks are sold by separate companies and are not supplied with the module.
4. Wire the jack appropriately to the data plate and snap the data plate assembly into the module grommet opening as shown (Detail M).
5. Proceed to "Wire Management Overview" instructions on page 19.



Assemble units as described herein only. To do otherwise may result in instability. All screws, nuts and bolts must be tightened securely and must be checked periodically after assembly. Failure to assemble properly, or to secure parts may result in assembly failure and personal injury.

Node In-Surface Power Module Installation

1. Orient the Node in-surface power module consistently straight, as shown and route the plug end down through the tabletop cutout. Press the module down completely into the cutout assuring it is straight, and consistent with other tables if being assembled (Figure 5 & Detail N).
2. Route the Node in-surface power module plug end through the locking ring opening as illustrated (Detail O).
3. Guide the locking ring up the power cord to the Node in-surface power module, then thread the locking ring up the power module, tight to the underside of the tabletop (Detail P).
4. Assure that the power module is straight as desired on the tabletop. Hold the power module by hand from underneath, then more completely tighten the locking ring by using a large locking pliers, or a hammer and flat blade screwdriver to tap on a ridge of the ring to rotate and tighten as illustrated (Detail P).
5. Proceed to "Wire Management Overview" instructions on page 19.

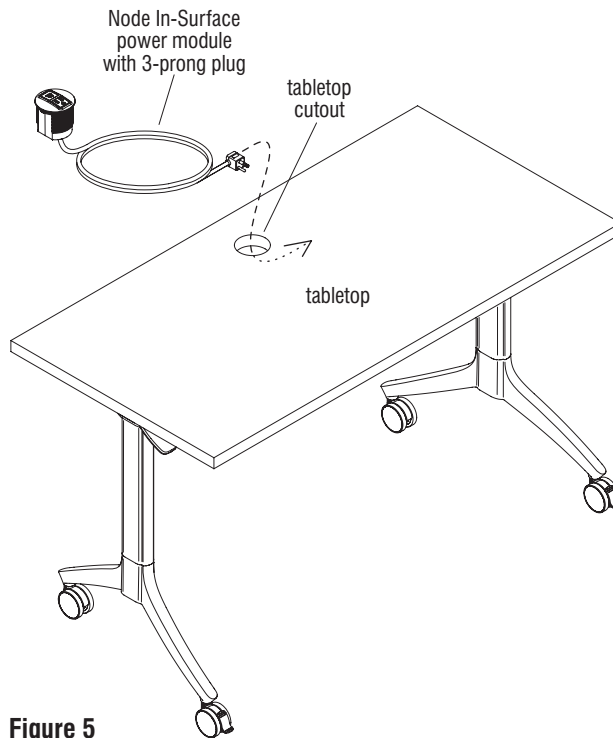
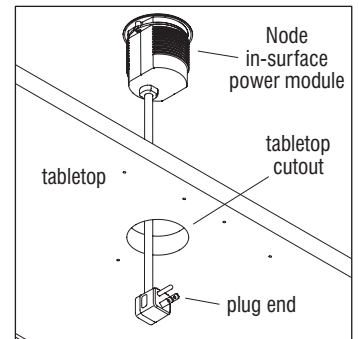
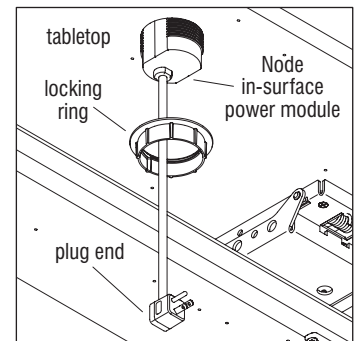

Figure 5



Detail N - (underside view)



Detail O - (underside view)

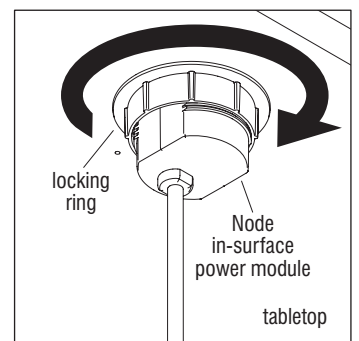

Detail P - (underside view)



Assemble units as described herein only. To do otherwise may result in instability. All screws, nuts and bolts must be tightened securely and must be checked periodically after assembly. Failure to assemble properly, or to secure parts may result in assembly failure and personal injury.

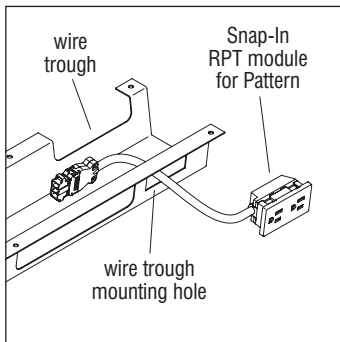

Detail Q

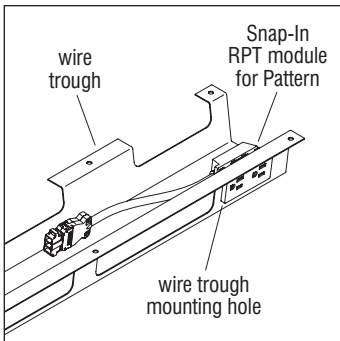

Detail R

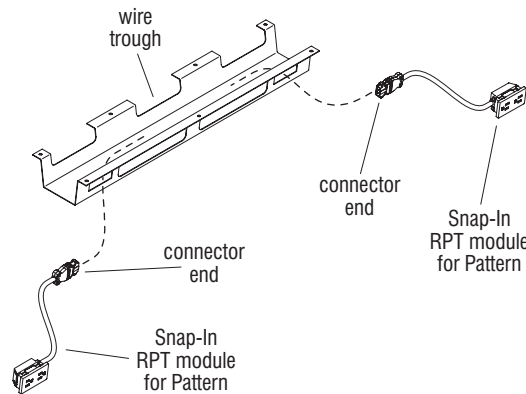

Figure 6

Snap-In RPT Module Installation

Note: Snap-In RPT modules install to the wire trough and the trough will be installed to the tabletop at a later step.

1. Route the connector end of each Snap-In module in through the rectangular-shaped module mounting holes on the wire trough as illustrated, routing the connector ends toward the middle of the trough, then snap the module receptacles into position (Figure 6 & Details Q & R).
2. If the table being assembled requires a grommet, proceed to “Grommet Overview” instructions on page 18, otherwise proceed to “Wire Management Overview” instructions on page 19.



Assemble units as described herein only. To do otherwise may result in instability. All screws, nuts and bolts must be tightened securely and must be checked periodically after assembly. Failure to assemble properly, or to secure parts may result in assembly failure and personal injury.

Grommet Overview

Note: Although the figures throughout this “Grommet” instructions illustrate a fixed-height nesting-top base table, the instructions apply to all Tributaire fixed-height training tables. Your configuration may vary.

Note: If the tables being assembled require a Dean or Nacre grommet installed into any tabletop cutouts, proceed to “Dean & Nacre Grommet Installation” instructions below. If a Node grommet is required, proceed to “Node Grommet Installation” instructions on this page.

Dean & Nacre Grommet Installation

1. Position the Dean or Nacre grommet above the tabletop cutout with the lid opening towards the user (Figure 1 & Detail A or B).
2. Push the grommets into each cutout, tapping lightly with a rubber mallet if required. Use caution to avoid scratching the grommet (Figure 1 & Detail A or B).
3. Secure the grommet to the tabletop by inserting two #6 x 1/2” screws through the holes on the inside of the module into the cut edge of the top (Detail A or B).
4. Proceed to “Wire Management Overview” instructions on page 19.

Node Grommet Installation

1. Position the Node grommet above the tabletop cutout as illustrated (Figure 1 & Detail C).
2. Push the grommet into the cutout, tapping lightly with a rubber mallet if required. Use caution to avoid scratching the grommet (Figure 1 & Detail C).
3. Secure the grommet to the tabletop by inserting one #6 x 1/2” screw through the hole on the inside of the module into the cut edge of the top (Detail C).

4. Proceed to “Wire Management Overview” instructions on page 19.

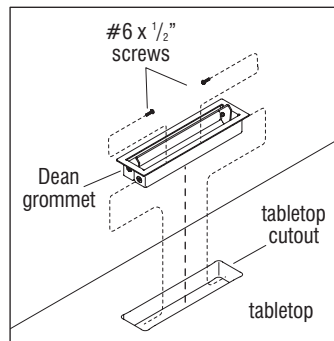

Detail A - Dean Grommet

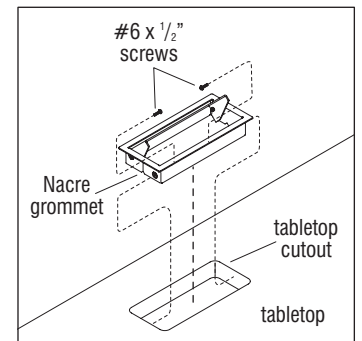

Detail B - Nacre Grommet

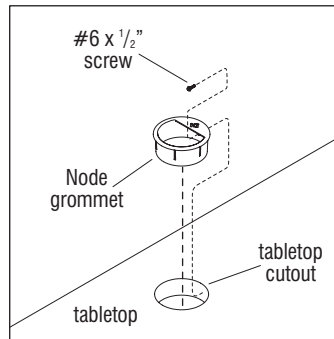

Detail C - Node Grommet

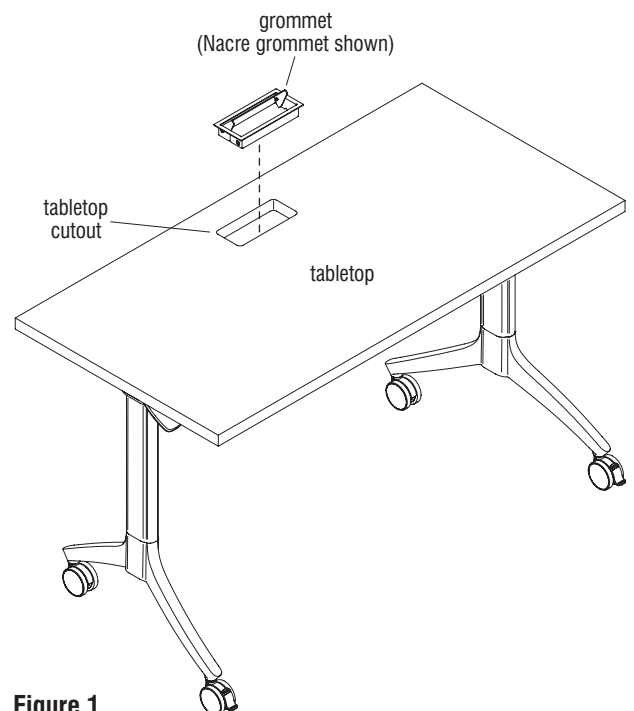

Figure 1



Assemble units as described herein only. To do otherwise may result in instability. All screws, nuts and bolts must be tightened securely and must be checked periodically after assembly. Failure to assemble properly, or to secure parts may result in assembly failure and personal injury.

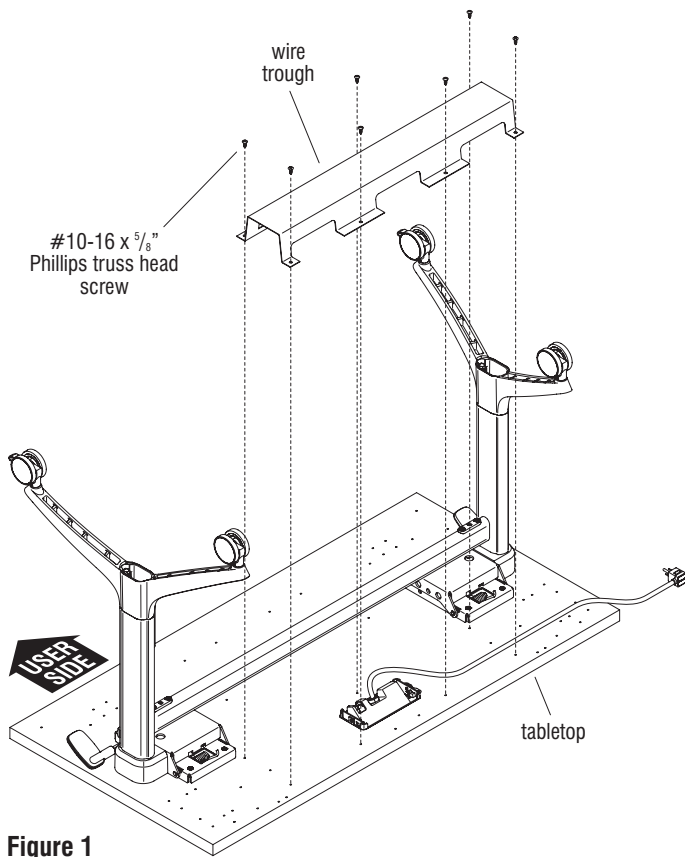

Figure 1

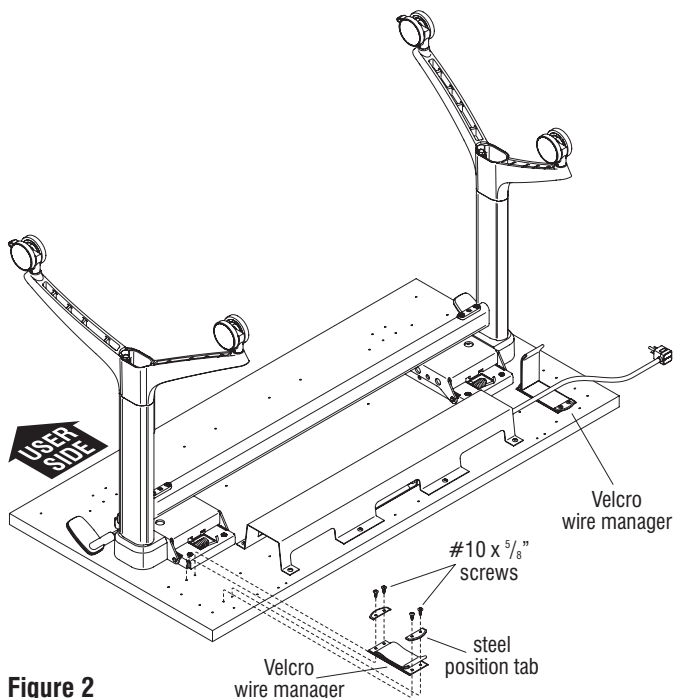

Figure 2

Wire Management Overview

Important: When turning a tabletop upside down onto a soft protective surface to install components, always take care to place a cloth or padding under any installed power module or grommet for added protection. Although the Tributaire table figures on this page is shown upside down, the wire trough and Velcro wire manager can be installed while the table is in the upright position.

Note: If the Tributaire training table being assembled requires a wire trough, go to “Wire Trough Installation” instructions below. If the table requires Velcro managers, go to “Velcro Wire Management Installation” instructions below.

Wire Trough Installation

1. If a power module with a pop-up feature was installed (Nacre®), make sure the cover is closed, then carefully rotate the table to be upside down on a soft, protective surface with padding under power module.

2. Position the wire trough over the wire trough mounting holes on the underside of the tabletop as illustrated, with the two smaller rectangular Snap-In RPT mounting holes (or Snap-In RPT modules) facing the front, user side of the table. Align the wire trough mounting holes with the pre-drilled holes in the underside of the tabletop, and secure wire troughs to tabletop using seven #10-16 x 5/8 inch Phillips truss head screws. Do not over-tighten (Figure 1).

3. If the table being assembled requires Velcro managers, proceed to “Velcro Wire Management” instructions below. If the table being assembled does not require Velcro wire managers, but will be ganged to another table, proceed to “Ganging Tables Overview” instructions on the next page. If the table does not require Velcro wire managers, or gangers, proceed to “Electrical Overview” instructions on page 23.

Velcro® Wire Management Installation

1. Position the two Velcro wire managers over the pre-drilled holes in the underside of the tabletop where illustrated. Locate and place two steel position tabs, one at each end over the mounting holes in the wire manager, then secure using four #10 x 5/8 inch screws, through the two position tabs, wire manager mounting holes and into the tabletop. Do not over-tighten (Figure 2).
2. If the table being assembled contains a power module with a 3-prong plug, you may strap in the desired cords using the installed Velcro wire managers at this time. If the table will contain a Pattern electrical system, wait to strap the cords in until instructed to at a later step (Detail A).

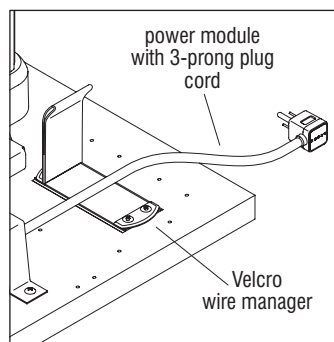

Detail A

3. If the table being assembled will be ganged to another table, proceed to “Ganging Tables Overview” instructions on the next page. If the table does not require gangers, proceed to “Electrical Overview” instructions on page 23.

Tributaire™ Collection - Fixed-Height Training Tables - Ganging
 Assembly Instructions



Assemble units as described herein only. To do otherwise may result in instability. All screws, nuts and bolts must be tightened securely and must be checked periodically after assembly. Failure to assemble properly, or to secure parts may result in assembly failure and personal injury.

Ganging Tables Overview

Important: When turning a tabletop upside down onto a soft protective surface to install components, always take care to place a cloth or padding under any installed power module or grommet for added protection. Although the Tributaire table figures on this page is shown upside down, the ganging pegs can be installed while the table is in the upright position.

Peg Installation

Note: Take note of correct peg mounting locations to assure proper latching for ganging. If the tables are to be ganged in a back-to-back configuration or the tables are to be ganged in a side-to-side configuration and no modesty panels are to be installed, use the hole pattern shown in Detail A for the back, non-user side of the table. If tables are to be ganged side-to-side and modesty are to be installed, use the hole pattern shown in Detail B.

1. Locate the four pre-drilled peg mounting locations, at each corner of each tabletop. Install a peg to each location using a #14 x 1/2" wood screw at each peg mounting location, taking into account if the table being assembled will have a modesty panel (Figure 1 & Details A & B).
2. Locate the four pre-drilled storage peg mounting locations, at each corner of each tabletop or the four mounting holes at the front, user side of the tabletop. Install a peg to each location using a #14 x 1/2" wood screw at each peg mounting location (Figures 1 & 2 & Details A, B & C).
3. Carefully turn the table to the upright position (Figure 3).

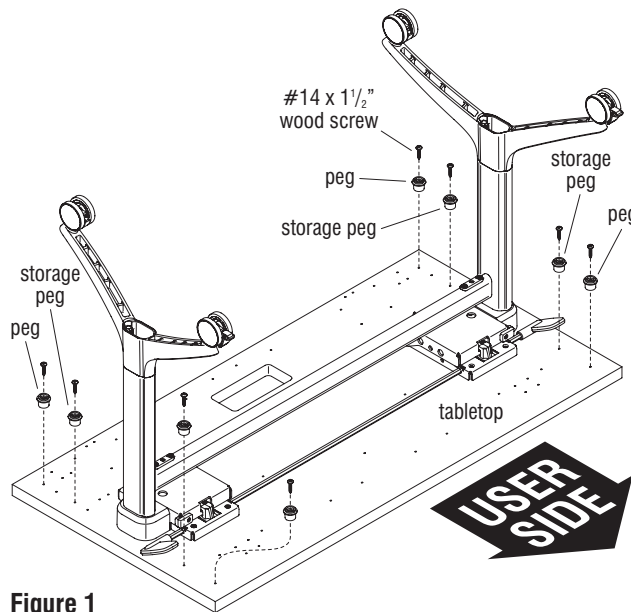

Figure 1

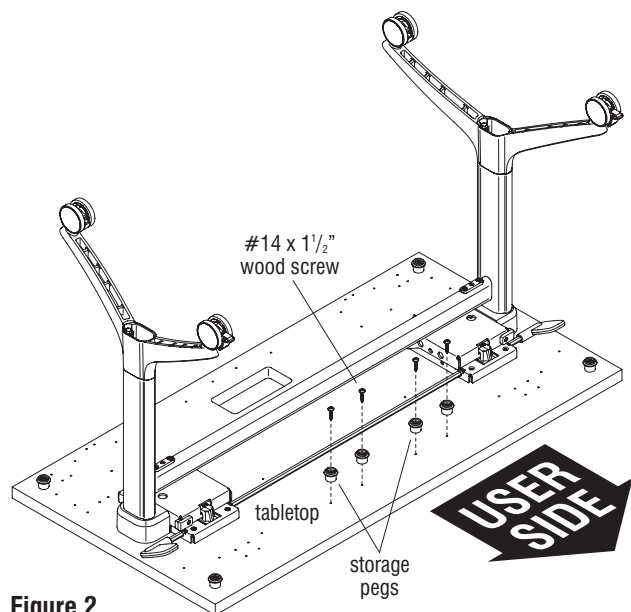
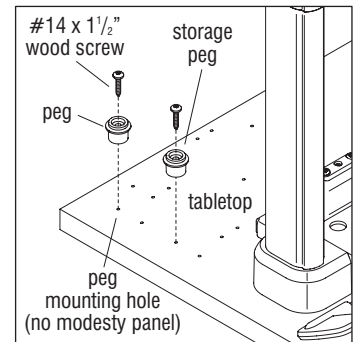
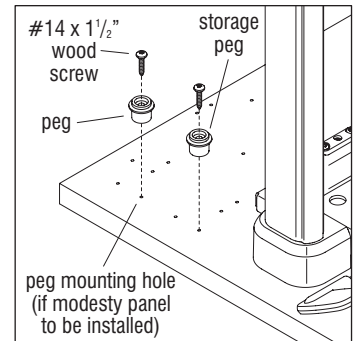

Figure 2



Detail A - No Modesty Panel



Detail B - Modesty Panel

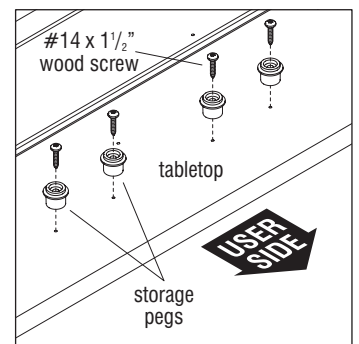

Detail C - Alternative Location



Assemble units as described herein only. To do otherwise may result in instability. All screws, nuts and bolts must be tightened securely and must be checked periodically after assembly. Failure to assemble properly, or to secure parts may result in assembly failure and personal injury.

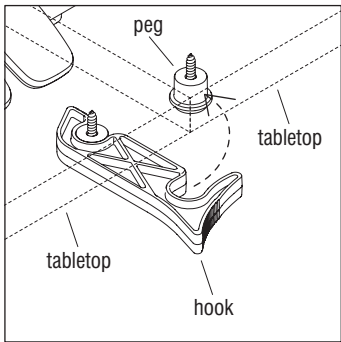

Detail D

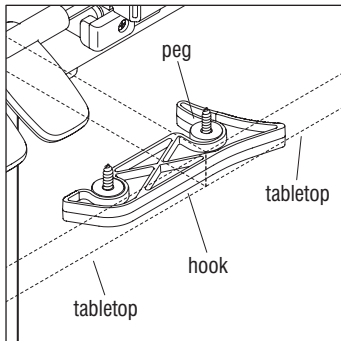

Detail E

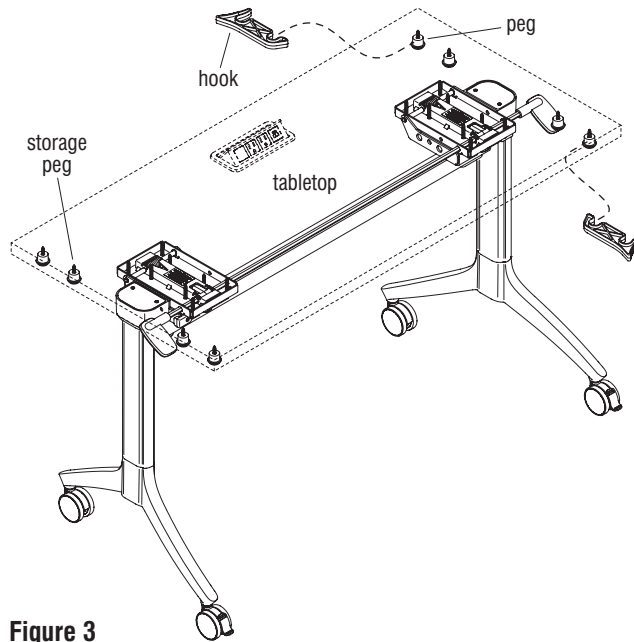

Figure 3

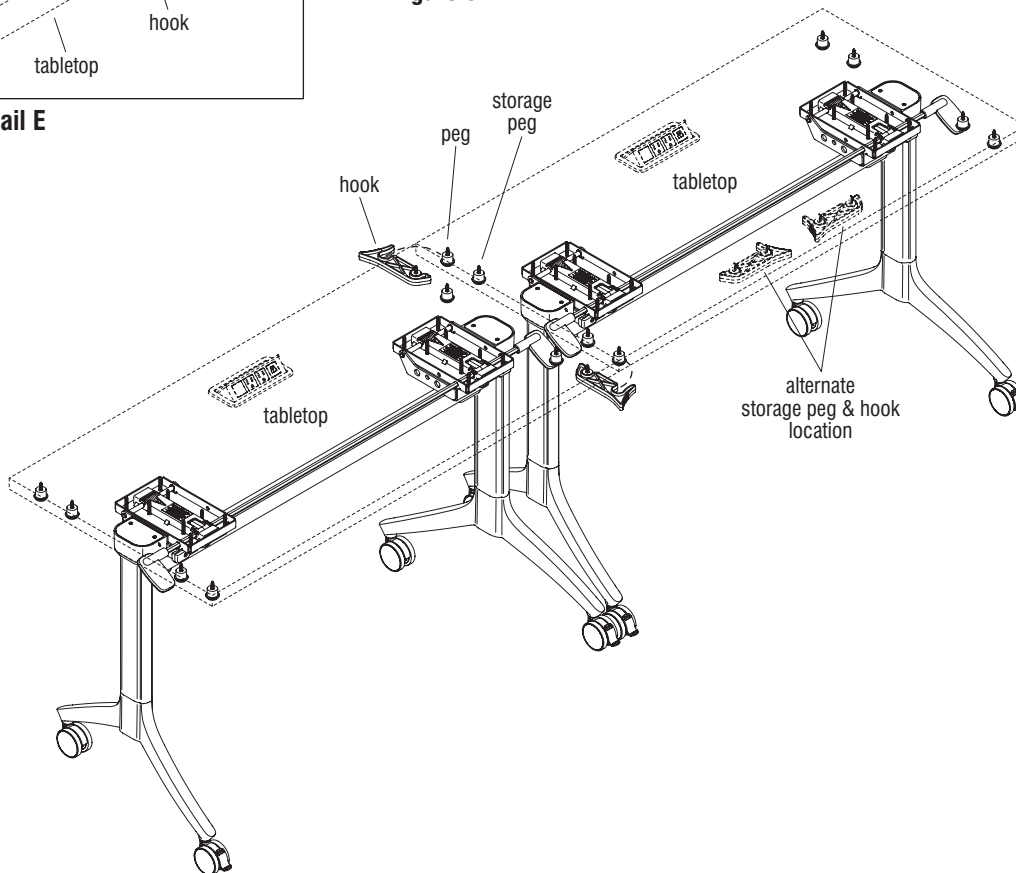

Figure 4 - Side-to-Side Ganging

Hook Installation

4. Position and snap the two ganging hooks onto their respective ganging pegs (Figure 3).

Ganging Tables

5. Move the two tables together side-to-side or back-to-back based on the desired configuration, such that the two pair of ganging pegs face each other. Swing the hooks to the opposite peg to securely gang tables together (Figure 4, Figure 5 on page 22 & Details D & E).
6. Position and snap any extra pegs onto the storage pegs. For hook storage, when tables are not paired, disconnect the table edge ganging hooks and move them to the storage pegs mounted either at each corner of the table or to the front user side of the table (Figure 4 & Figure 5 on page 22).
7. If the table being assembled will have electrical, proceed to "Electrical Overview" instructions on page 23. If the table does not require electrical, but requires some additional wire managers, proceed to "Wire Management Overview" instructions on page 28. If the table does not require electrical, or additional wire management but requires a modesty panel, proceed to "Modesty Panel Overview" instructions on page 31. If the table requires none of the above, but has a power module, proceed to "Connection to Power Source Overview" instructions, otherwise move the table to the final location of use.

■ Tributaire™ Collection - Fixed-Height Training Tables - Ganging

Assembly Instructions



Assemble units as described herein only. To do otherwise may result in instability. All screws, nuts and bolts must be tightened securely and must be checked periodically after assembly. Failure to assemble properly, or to secure parts may result in assembly failure and personal injury.

Ganging Tables (cont.)

8. If the table being assembled will have electrical, proceed to "Electrical Overview" instructions on page 23. If the table does not require electrical, but requires some additional wire managers, proceed to "Wire Management Overview" instructions on page 28. If the table does not require electrical, or additional wire management but requires a modesty panel, proceed to "Modesty Panel Overview" instructions on page 31. If the table requires none of the above, but has a power module, proceed to "Connection to Power Source Overview" instructions, otherwise move the table to the final location of use.

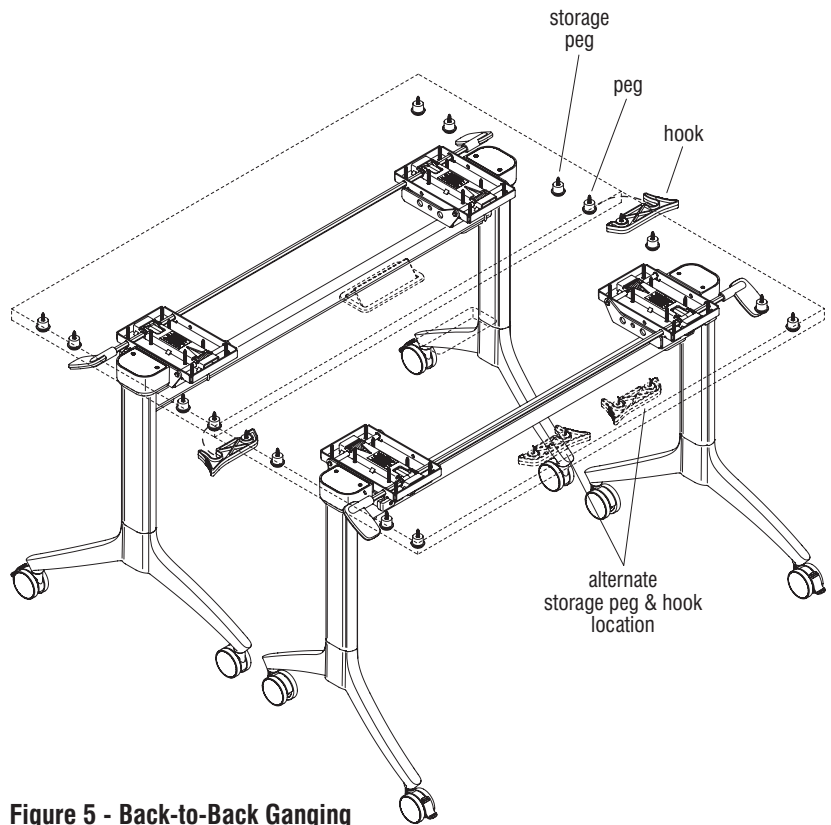
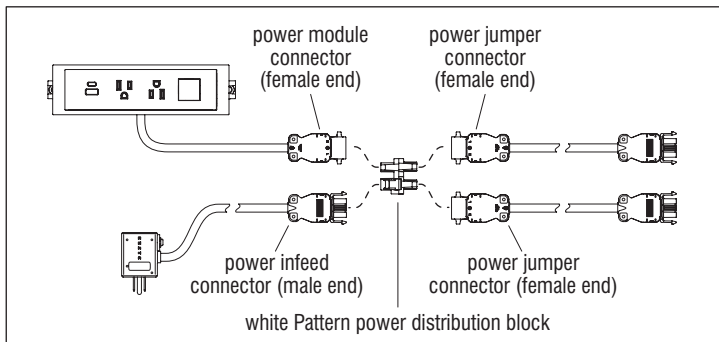

Figure 5 - Back-to-Back Ganging



Assemble units as described herein only. To do otherwise may result in instability. All screws, nuts and bolts must be tightened securely and must be checked periodically after assembly. Failure to assemble properly, or to secure parts may result in assembly failure and personal injury.



Detail A - Connection Locations with White Power Distribution Block

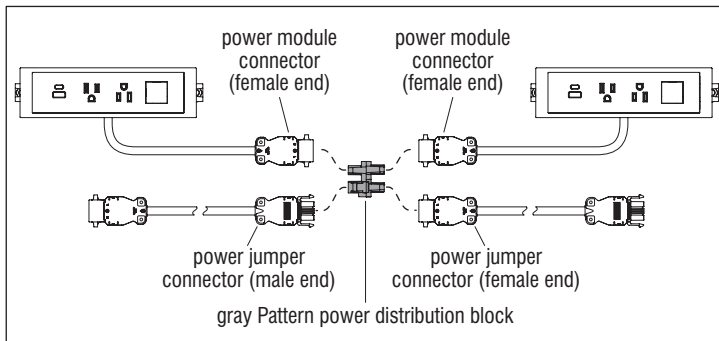

Detail B - Connection Locations with Grey Power Distribution Block

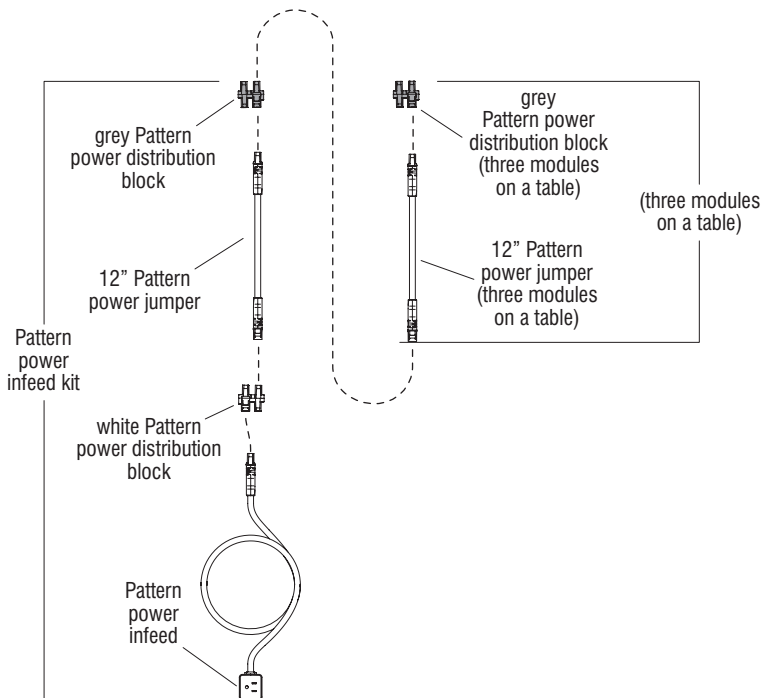

Figure 1 - (top view)

Electrical Overview

Note: If the tables being assembled contain a power module with 3-prong plug, proceed to “Wire Management Overview” instructions on page 28. If the tables being assembled contain a Pattern electrical system, proceed to the instructions below.

Pattern Electrical System Installation

Note: The Pattern electrical system is ETL Listed, evaluated to safety standard UL 962A (USA) and CAN/CSA-C22.2 No. 308 (Canada). It allows up to ten power distribution blocks and up to 50’ of power

jumpers (in either direction of the power infeed), whichever comes first, can allow up to eighteen power modules depending on table width, and connects to one 15-amp power supply cord (power infeed). The power supply cord does not count toward the maximum 50’ of power jumpers.

Note: The Pattern quick-release tool is a simple tool designed to help remove the power connector ends from the Pattern power distribution blocks. If reconfiguration of the Pattern electrical system is required, reference “Pattern Quick-Release Tool” instructions on page 35.

Pattern Power Infeed Kit Assembly

Important: Details A & B are provided as a visual guide to illustrate the different white and grey power distribution blocks, and which male/female connector ends plug into each port.

1. For a run of tables, start Pattern electrical system assembly with the table that will contain the Pattern power infeed. Locate one Pattern power infeed, one white power distribution block, one grey power distribution block and one 12” Pattern power jumper. Plug the power infeed into the white power distribution block first, as illustrated (Figure 1 & Detail A).
2. Plug the female end of the 12” power jumper into either male port opposite to the power infeed connection on the white distribution block (Figure 1 & Detail A).
3. Plug the previously installed (step 2) 12” Pattern power jumper end into a grey power distribution block as illustrated (Figure 1 & Detail B).
4. If the designated power infeed table contains three power modules, an additional 12” Pattern power jumper and grey Pattern power distribution block on the end will be required after the first grey distribution block (Figure 1).



Assemble units as described herein only. To do otherwise may result in instability. All screws, nuts and bolts must be tightened securely and must be checked periodically after assembly. Failure to assemble properly, or to secure parts may result in assembly failure and personal injury.

Pattern Power Infeed Kit Assembly (cont.)

5. Route the Pattern power infeed kit into the end of the wire trough of the designated power infeed table (Figure 2).
6. To aid in making connections, temporarily pull from the wire trough's rear access holes, the previously installed power module connector ends, and the power distribution blocks connected in line to the power infeed kit. Plug each of the installed power module's connector ends into the open ports on the nearest white or grey power distribution blocks, then place all cords and power distribution blocks back into the wire trough after connections are made (Details C & D).

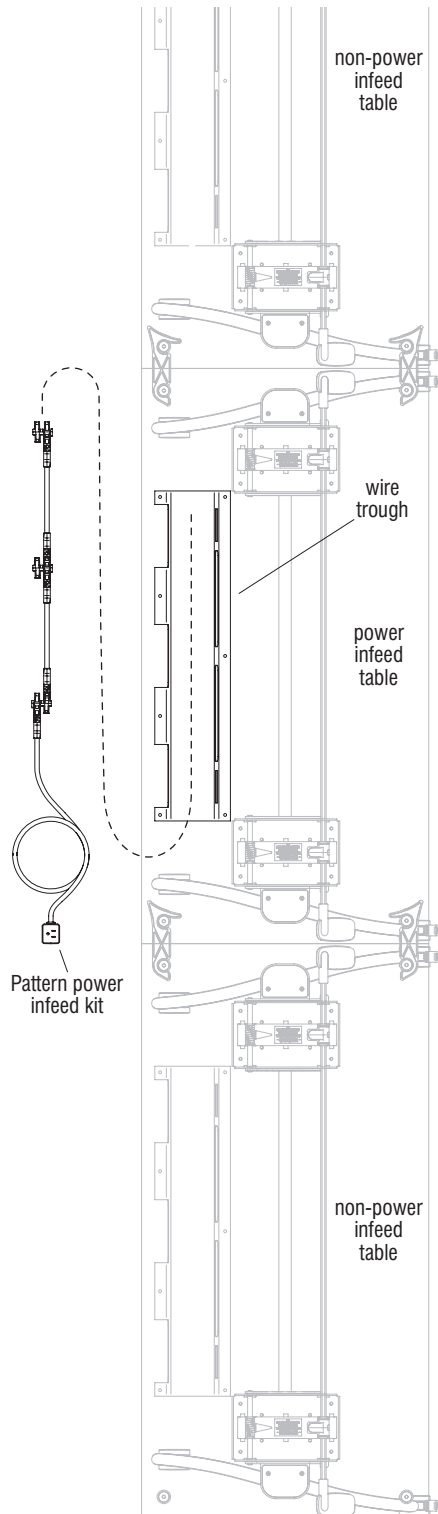
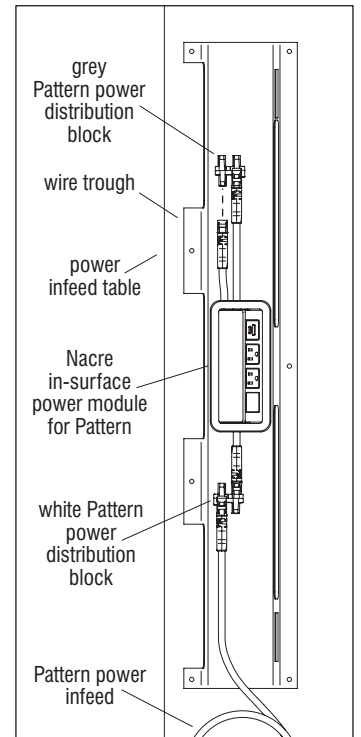
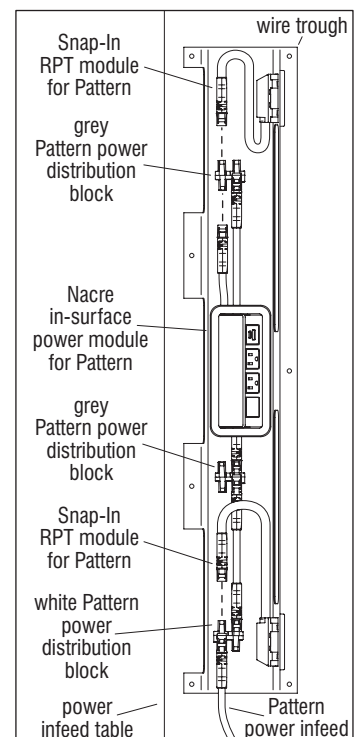

Figure 2 - (top view)



Detail C - (top view)



Detail D - (top view)



Assemble units as described herein only. To do otherwise may result in instability. All screws, nuts and bolts must be tightened securely and must be checked periodically after assembly. Failure to assemble properly, or to secure parts may result in assembly failure and personal injury.

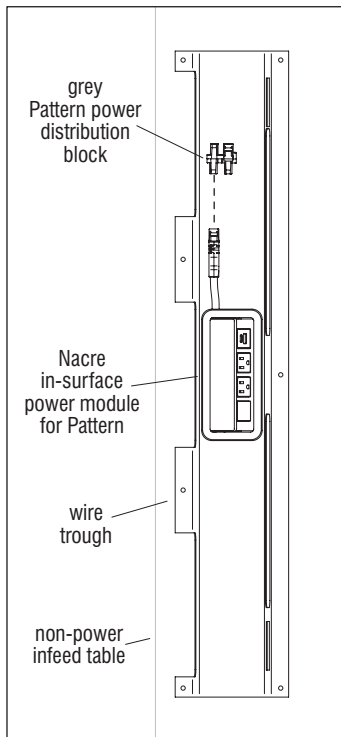

Detail E - (top view)

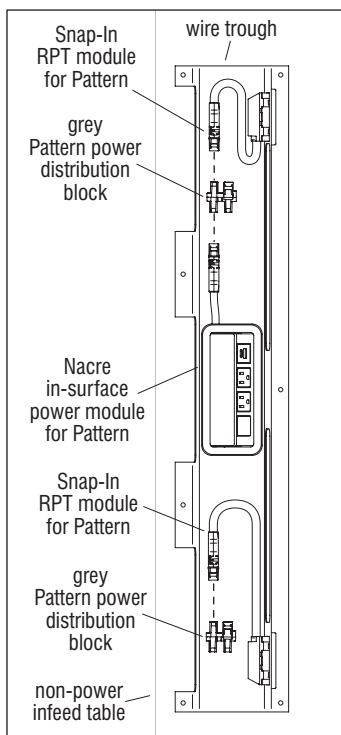

Detail F - (top view)

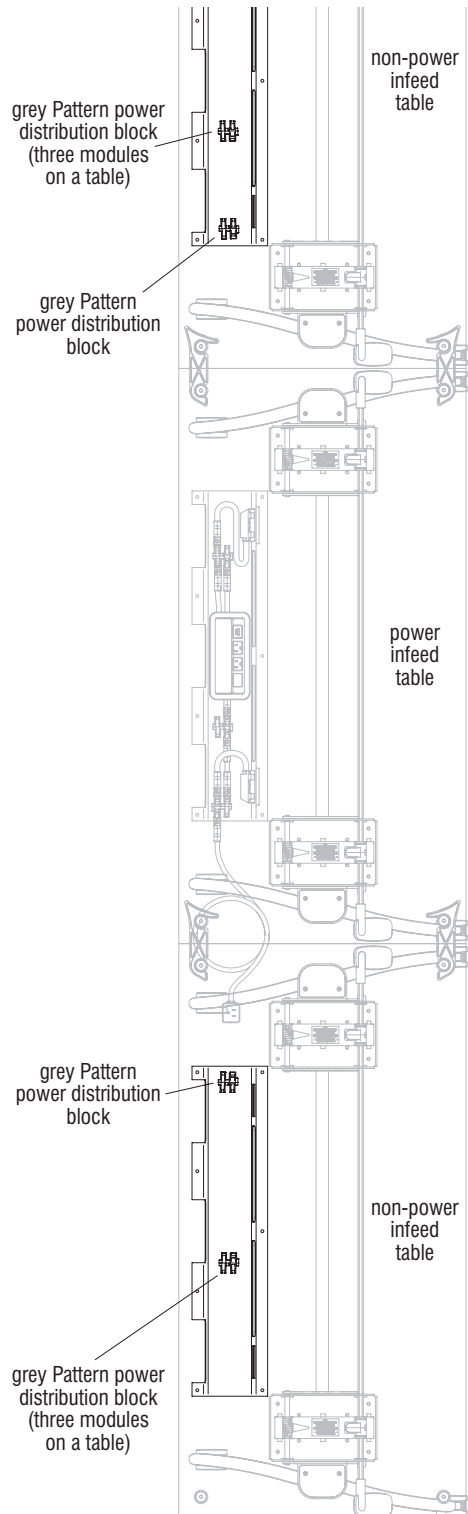

Figure 3 - (top view)

Pattern Power Distribution Block Placement

7. Locate and distribute the required number of loose grey power distribution blocks along the run of non-power infeed tables which are to receive Pattern electrical. One grey distribution block is required for every two power modules on a table. No more than two grey distribution blocks will be used per non-power infeed table (Figure 3).
8. To aid in making connections, temporarily pull from the wire trough's rear access holes, the power module connector ends. Plug each power module connector end into a port on a grey power distribution block from the previous step. No more than two power modules may be connected to any one grey power distribution block. Place all cords with grey power distribution blocks back into the wire trough after connections are made (Details E & F).



Assemble units as described herein only. To do otherwise may result in instability. All screws, nuts and bolts must be tightened securely and must be checked periodically after assembly. Failure to assemble properly, or to secure parts may result in assembly failure and personal injury.

Pattern Power Jumper Assembly

9. Locate and distribute the required number of 12" power jumpers along the run of non-power infeed tables which include installed power modules (Figure 4).

10. To aid in making connections, temporarily pull from the wire trough's rear access holes, the power distribution blocks connected to the power module connector ends. Plug the female connector end of each 12" power jumper into the grey power distribution block that is closest to the power infeed table, then route the open power jumper end in through the wire trough access hole and plug the opposite end of the power jumper into the table's other grey power distribution block. Place all cords with grey power distribution blocks back into the wire trough after connections are made (Details G & H).

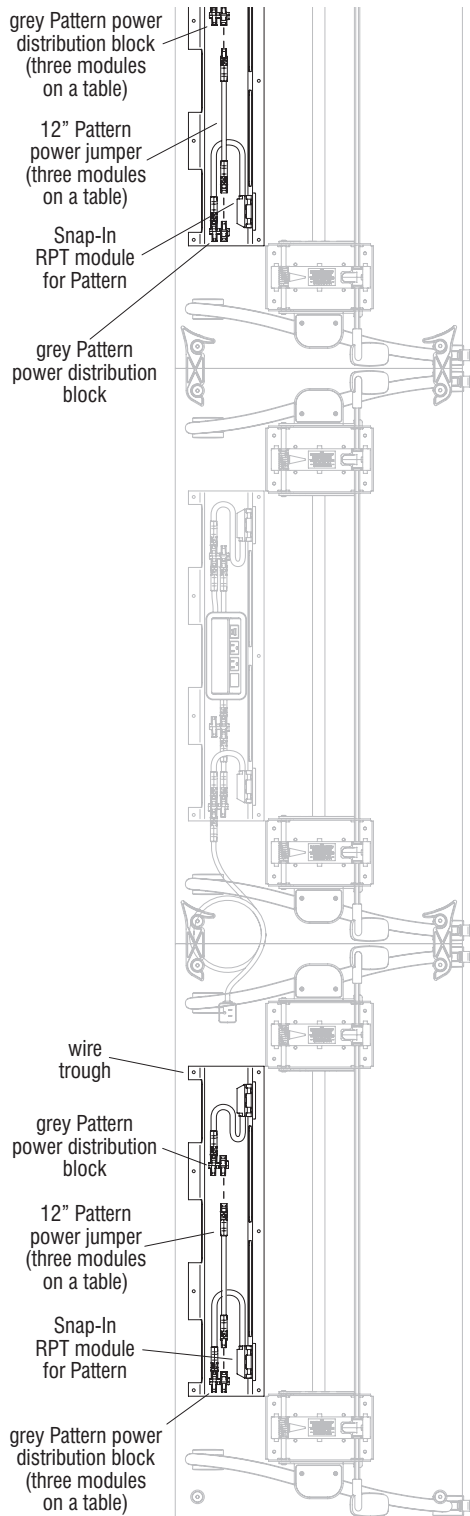
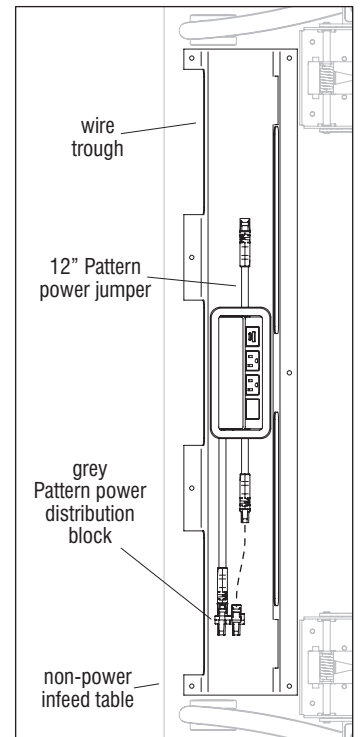
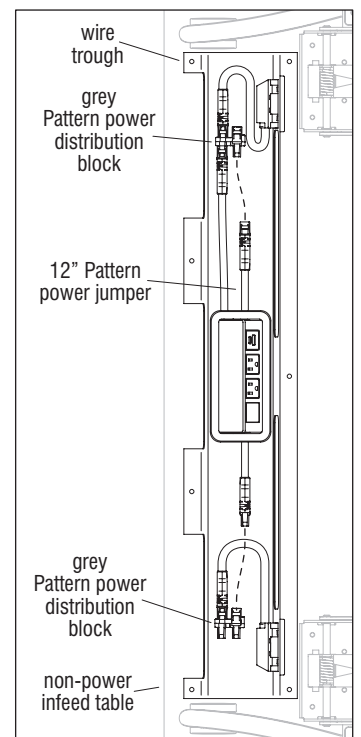

Figure 4 - (top view)



Detail G - (top view)



Detail H - (top view)



Assemble units as described herein only. To do otherwise may result in instability. All screws, nuts and bolts must be tightened securely and must be checked periodically after assembly. Failure to assemble properly, or to secure parts may result in assembly failure and personal injury.

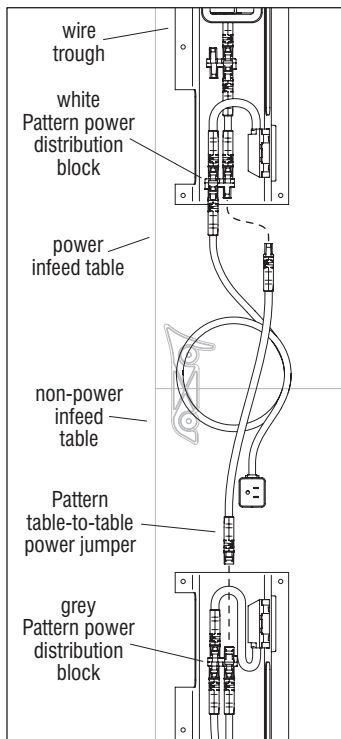

Detail I - (top view)

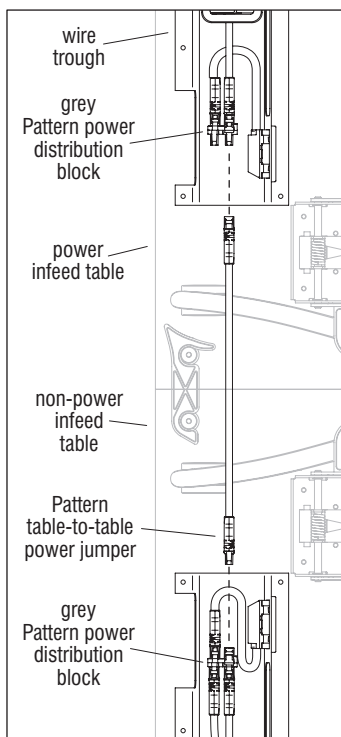

Detail J - (top view)

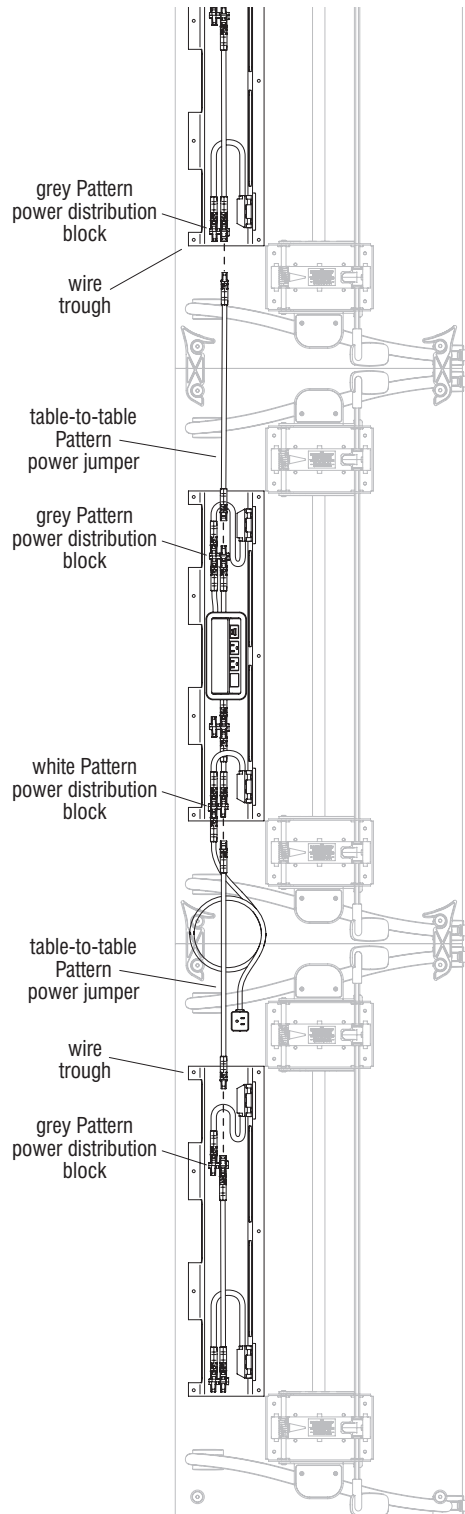

Figure 5 - (top view)

Pattern Table-to-Table Power Jumper Kit Assembly

11. Locate and distribute the required number of table-to-table power jumpers along the run of non-power infeed tables which must have power connected between tables. To aid in making connection, temporarily pull from the wire trough's rear access holes, the power distribution blocks with power module connector ends and 12" power jumpers on them (Figure 5).
12. Starting the assembly process at the Pattern power infeed table and working outward, take a Pattern table-to-table power jumper and plug the female connector end into a power distribution block in the open end of the wire trough. Next, plug the table-to-table power jumper's male connector end into a grey power distribution block in the adjacent non-power infeed table's wire trough. If the power infeed table is in the middle of a run of tables, repeat the process above for the table in the other direction (Figure 5 & Detail I).
13. Continuing with table-to-table power jumper assembly on the remaining tables, plug a power jumper's female connector end into the grey power distribution block at the end of the trough, and plug the opposite end's male connector into the grey power distribution block in the end of the trough of the adjacent table. Repeat this step until all tables within the run are connected with Pattern table-to-table power jumpers (Figure 5 & Detail J).
14. Proceed to "Wire Management Overview" instructions on the next page.

Note: Be sure that all cords and power distribution blocks that were removed to make connections are back inside the wire troughs. The only components that should remain outside of a wire trough are the table-to-table power connectors that run between tables.

■ Tributaire™ Collection - Fixed-Height Training Tables - Wire Management

Assembly Instructions



Assemble units as described herein only. To do otherwise may result in instability. All screws, nuts and bolts must be tightened securely and must be checked periodically after assembly. Failure to assemble properly, or to secure parts may result in assembly failure and personal injury.

Wire Management Overview

Note: Although the figures throughout the “Wire Management” instructions illustrate a fixed-height nesting-top base table, the instructions apply to all Tributaire training tables. Your configuration may vary.

Note: If the Tributaire training table being assembled requires wire management, reference the following sections below based on the wire manager your table requires: Go to page 28 to strap power module cords into previously installed Velcro wire managers, page 29 for vertical wire manager, or page 30 for strain relief clips.

Wire Management using Velcro® Wire Managers

1. Route the desired Pattern power infeed or power module cord to the desired Velcro manager and strap the cord in (Figure 1).
2. Proceed to “Vertical Wire Manager Installation” instructions on the next page.

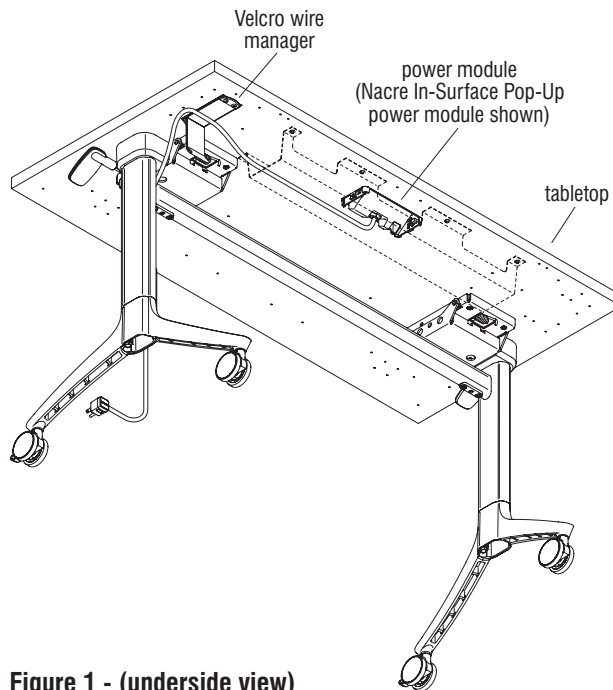

Figure 1 - (underside view)



Assemble units as described herein only. To do otherwise may result in instability. All screws, nuts and bolts must be tightened securely and must be checked periodically after assembly. Failure to assemble properly, or to secure parts may result in assembly failure and personal injury.

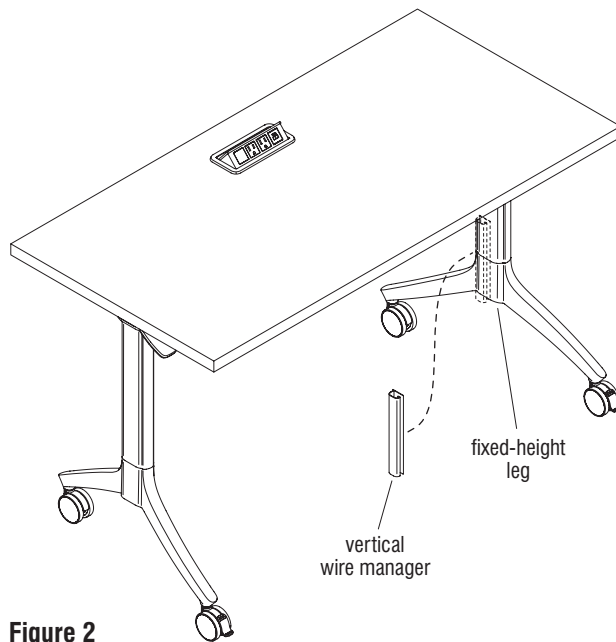

Figure 2

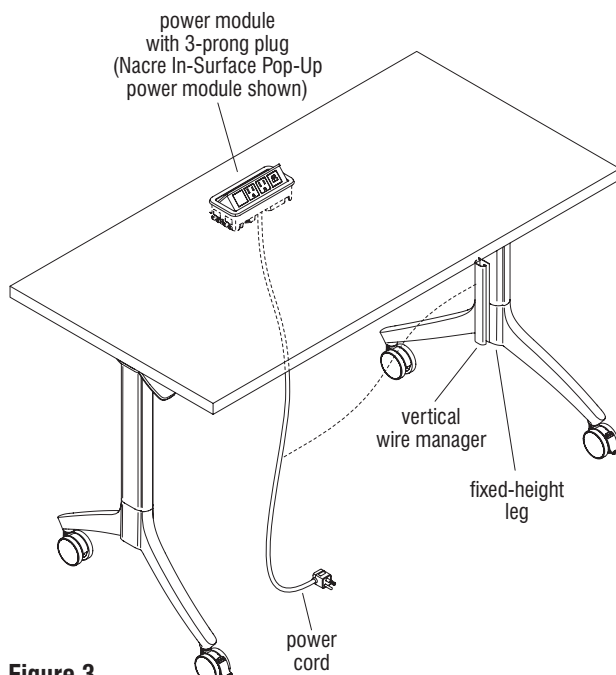

Figure 3

Vertical Wire Manager Installation

1. Position the vertical wire manager in the desired location against the leg which is closest to a power source. Align the vertical wire manager centered, straight along the leg, and top of the wire manager to be 2" down from the bottom of the stringer. Then mark the location of the wire manager and move the unit away (Figure 2).
2. Remove the adhesive backing from the vertical wire manager to expose the adhesive surface. Position the wire manager back to the marked location, centered on the leg, and press firmly along the adhesive area (Figure 2).
3. Insert the power module cord into the wire manager (Figure 3).
4. If the table being assembled requires any strain relief clips, proceed to "Strain Relief Clip Installation" instructions on the next page. If the table does not require clips, but requires a modesty panel, proceed to "Modesty Panel Overview" instructions on page 31, otherwise proceed to "Connections to Power Source Overview" instructions on page 33.

■ Tributaire™ Collection - Fixed-Height Training Tables - Wire Management

Assembly Instructions



Assemble units as described herein only. To do otherwise may result in instability. All screws, nuts and bolts must be tightened securely and must be checked periodically after assembly. Failure to assemble properly, or to secure parts may result in assembly failure and personal injury.

Strain Relief Clip Installation

Note: Tabletops have multiple mounting hole locations specifically used for cord strain relief clips but unused pre-drilled holes may be used if desired. Install strain relief clips frequently to restrain the power module cables along the desired path underneath the tabletops. Your configuration may vary.

1. Locate strain relief clips and position them at the desired locations above unused pre-drilled holes (Figure 4 & Detail A).
2. Insert the cable into the openings of the clips. Secure the clips to the tabletop using one #10 x 3/4" screw per clip (Figure 4 & Detail A).
3. If the table being assembled requires a modesty panel, proceed to "Modesty Panel Overview" instructions on page 31, otherwise proceed to "Connections to Power Source Overview" instructions on page 33.

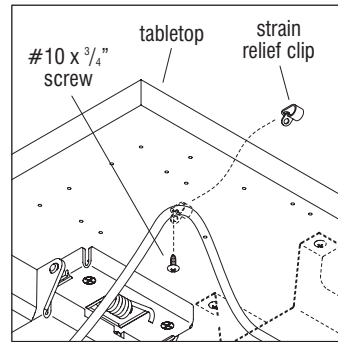

Detail A

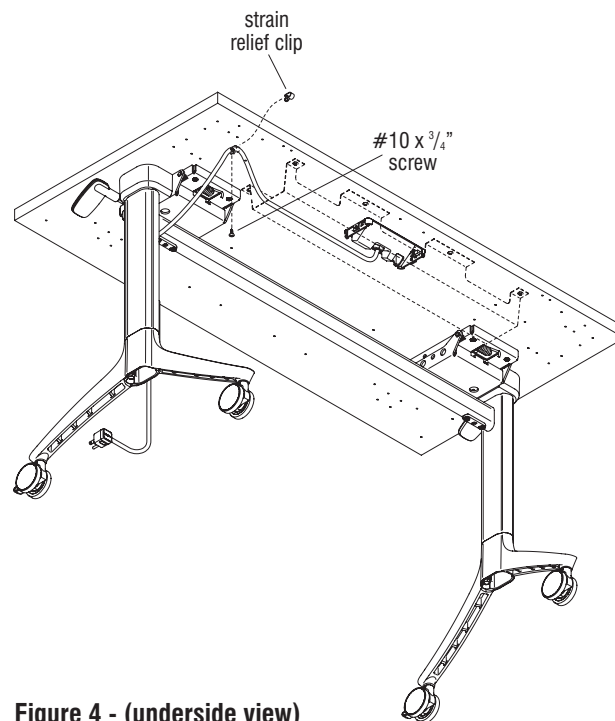
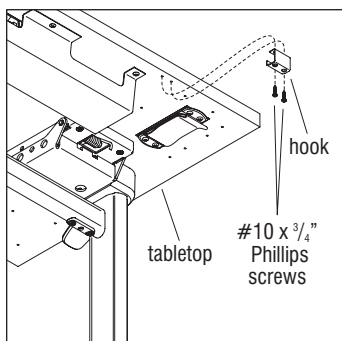

Figure 4 - (underside view)



Assemble units as described herein only. To do otherwise may result in instability. All screws, nuts and bolts must be tightened securely and must be checked periodically after assembly. Failure to assemble properly, or to secure parts may result in assembly failure and personal injury.



Detail A - (underside view)

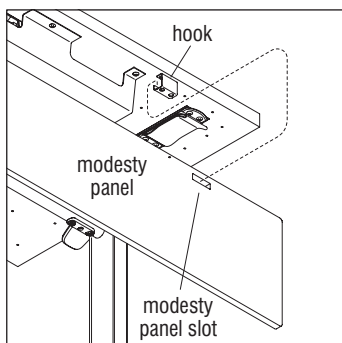

Detail B - (underside view)

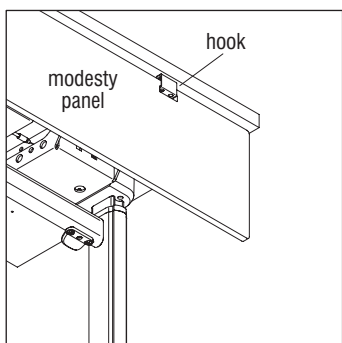

Detail C - (underside view)

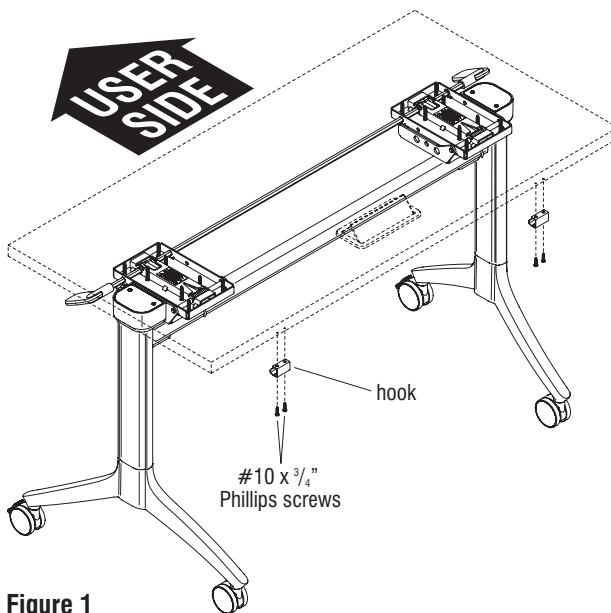

Figure 1

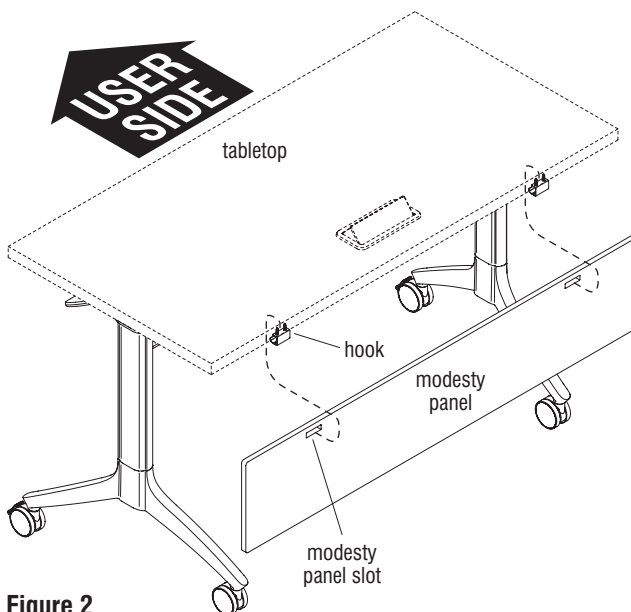

Figure 2

Modesty Panels Overview

Note: Although the figures throughout the "Modesty Panel" instructions illustrate a fixed-height nesting-top base table, the instructions apply to all Tributaire training tables. Your configuration may vary.

Polyester Felt Modesty Panel Installation

Note: The following instruction is for installing the polyester felt modesty panel to 30-72" wide Tributaire tables. Tables 30" to 48" wide require two hooks, and tables 54" or wider require three hooks. This instruction illustrates the modesty panel installation to 48" wide tables. Your configuration may vary.

1. Position one hook underneath the back, non-user side of the tabletop at the pre-drilled location as illustrated in Figure 1 & Detail A. Orient the hook to face the user side of the table. Align the mounting holes of the hook with the pre-drilled holes underneath the tabletop and secure using two #10 x 3/4" Phillips screws. Repeat this process to secure the remaining hooks to the table (Figure 1 & Detail A).
2. Position the modesty panel underneath the back, non-user side of the tabletop, near the hooks. Using the slots on the panel, hang the panel onto each hook (Figure 2, Details B & C).
3. If the table being assembled contains a power module, proceed to "Connections to Power Source Overview" instructions on page 33, otherwise move the table to the final location of use.

Tributaire™ Collection - Fixed-Height Training Tables - Modesty Panel

Assembly Instructions



Assemble units as described herein only. To do otherwise may result in instability. All screws, nuts and bolts must be tightened securely and must be checked periodically after assembly. Failure to assemble properly, or to secure parts may result in assembly failure and personal injury.

Laminate Modesty Panel Installation

Note: The following instruction is for installing the laminate modesty panel to 30"-72" wide Tributaire tables. Tables 30" to 48" wide require two modesty panel hinges, and tables 54" or wider require three modesty panel hinges. This instruction illustrates the modesty panel installation to 48" wide tables. Your configuration may vary.

1. Position one modesty panel hinge underneath the back, non-user side of the tabletop at the pre-drilled location, making sure the user side of the hinge is facing the user side of the table (Figure 3 & Detail D). If modesty panel hinges are not oriented correctly, the modesty panel will not nest properly when the tabletop is in the nesting position and disassembly and reassembly will be required. Align the mounting holes of the hinge with the pre-drilled holes underneath the tabletop and secure using two #10-16 x 5/8" Phillips screws. Repeat this process to secure the remaining hinges to the table (Figure 3 & Detail E).

2. Locate the nesting bumper mounting hole at each bottom corner of the laminate modesty panel. Align the nesting bumpers with the mounting holes and secure using one #10-16 x 5/8" Phillips truss head screw per bumper (Detail G).

Note: The assistance of a second person may be required to install the laminate modesty panel to the hinges, depending on the size of the modesty panel.

3. Position the modesty panel underneath the table on the user side of the hinges. With the assistance of a second person, if needed, have one person hold the modesty panel in position near the hinges, while the second person aligns the mounting holes of the panel with the mounting holes on the hinges and secure

together using two #10-16 x 5/8" Phillips truss head screw per hinge (Figure 4).

Overview" instructions on page 33, otherwise move the table to the final location of use.

4. If the table being assembled contains a power module, proceed to "Connections to Power Source

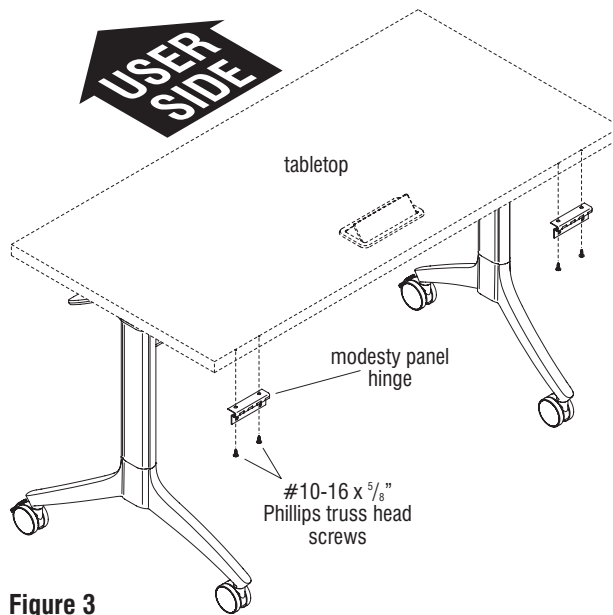

Figure 3

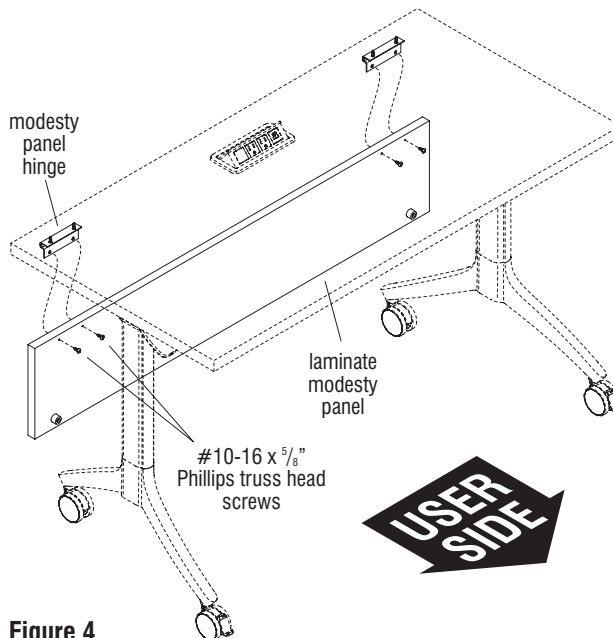
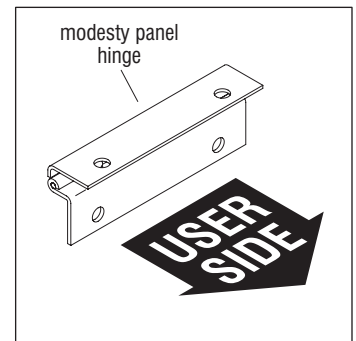
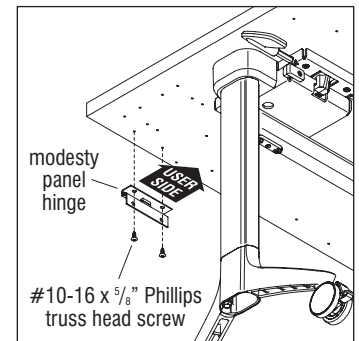

Figure 4



Detail D



Detail E - (underside view)

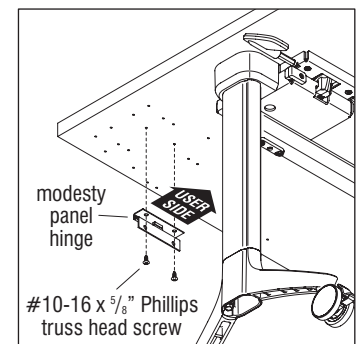

Detail F - (underside view)

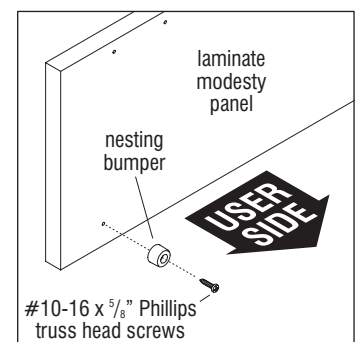

Detail G

GROUNDING INSTRUCTIONS

This product is for use on a nominal 120-volt circuit and has a grounding plug that looks like the plug illustrated in Detail B. Make sure that the product is connected to an outlet having the same configuration as the plug. No adapter should be used with this product.



CAUTION Assemble units as described herein only. To do otherwise may result in instability. All screws, nuts and bolts must be tightened securely and must be checked periodically after assembly. Failure to assemble properly, or to secure parts may result in assembly failure and personal injury.

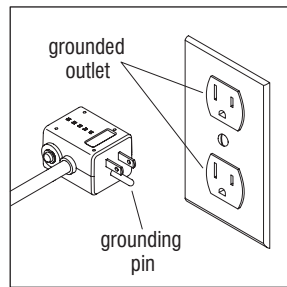

Detail A

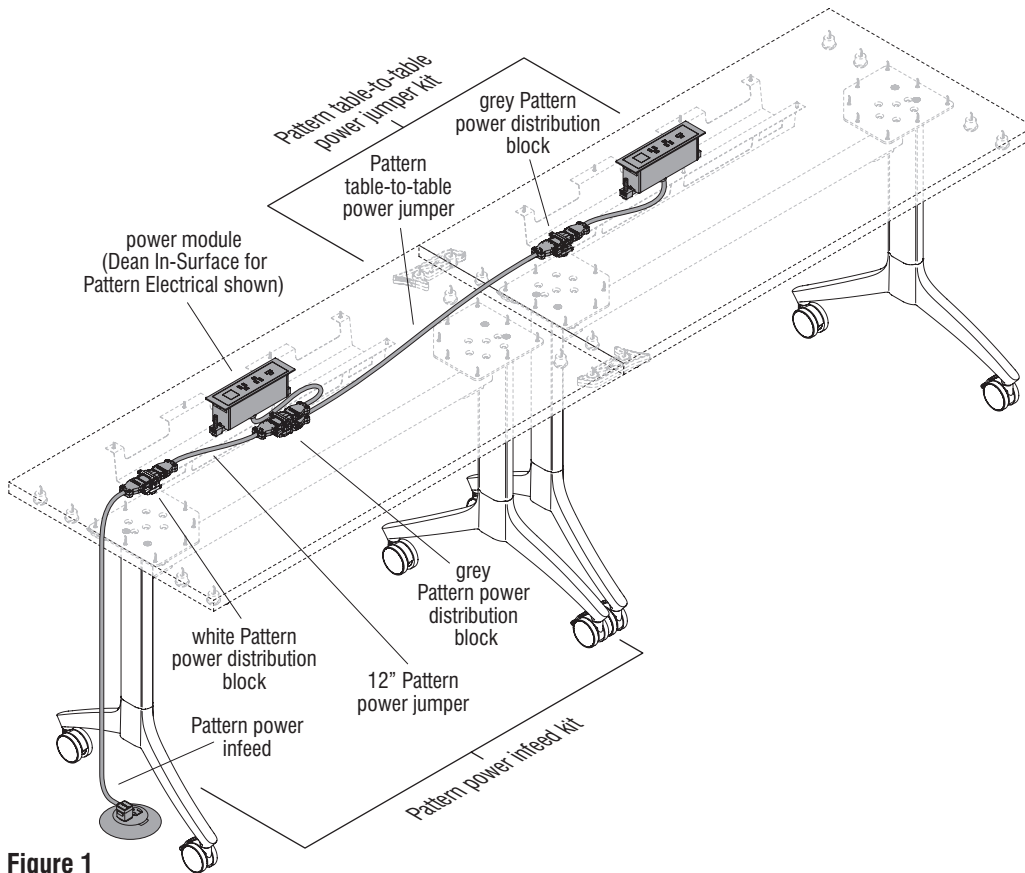

Figure 1

Connections to Power Source Overview

Note: If the tables being assembled contain power modules with 3-prong plugs, proceed to page 34. If the tables being assembled use the Pattern electrical system, proceed to the instructions below.

Connections to Power Source - Pattern Electrical System

Warning: Never attach more than one power infeed to a chain of devices. Always check to be certain that the system is not already powered from another source before attaching an infeed.

1. Place tables at their final location and lock the two front, user side casters in place on each table (Figure 1).
2. Plug the power infeed connector end into an appropriate location in the Pattern system only after all other components are installed. Plug into a source power outlet. Plug an electrical device into a power module on the Pattern electrical system to verify power. If there is no power, verify that there are no more than ten power distribution blocks used on the system, and that the total length of the system and all interconnecting cables (exclusive of the power infeed unit) does not exceed 50 feet, or 600 inches.
3. Once the connection with power source has been identified and corrected, press the reset button on the 3-prong plug end of the Pattern power infeed.

■ Tributaire™ Collection - Fixed-Height Training Tables - Connections to Power Source

Assembly Instructions



Assemble units as described herein only. To do otherwise may result in instability. All screws, nuts and bolts must be tightened securely and must be checked periodically after assembly. Failure to assemble properly, or to secure parts may result in assembly failure and personal injury.

GROUNDING INSTRUCTIONS

This product is for use on a nominal 120-volt circuit and has a grounding plug that looks like the plug illustrated in Detail A. Make sure that the product is connected to an outlet having the same configuration as the plug. No adapter should be used with this product.

Connections to Power Source - Power Modules with 3-Prong Plug

1. Place tables at their final location and lock the two front, user side casters in place on each table (Figure 2).
2. Plug the power module into an outlet only after all other components have been installed.

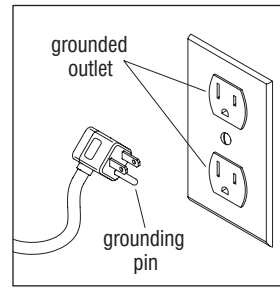

Detail B

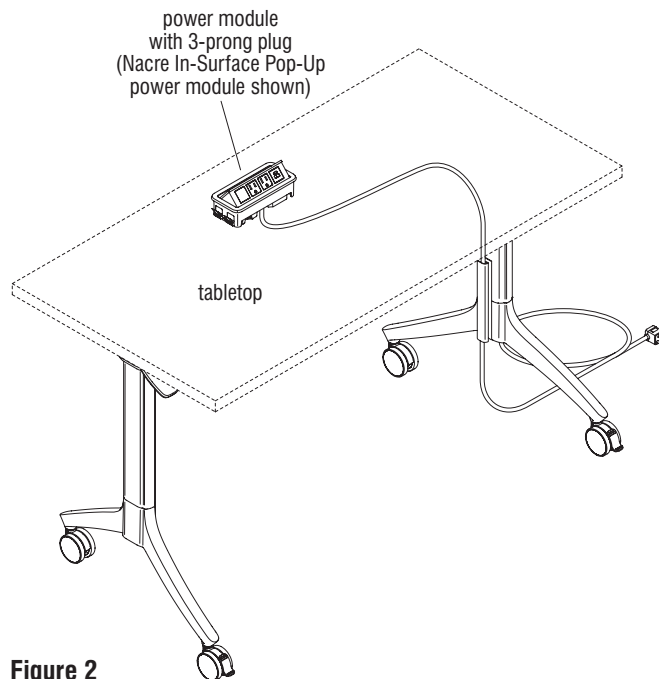
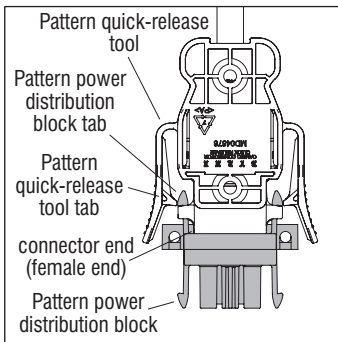

Figure 2



Assemble units as described herein only. To do otherwise may result in instability. All screws, nuts and bolts must be tightened securely and must be checked periodically after assembly. Failure to assemble properly, or to secure parts may result in assembly failure and personal injury.



Detail A

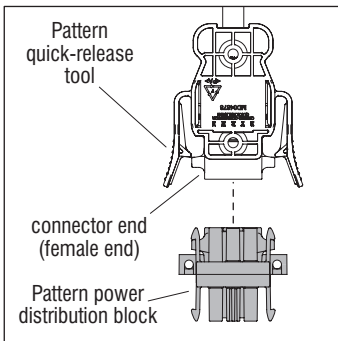

Detail B

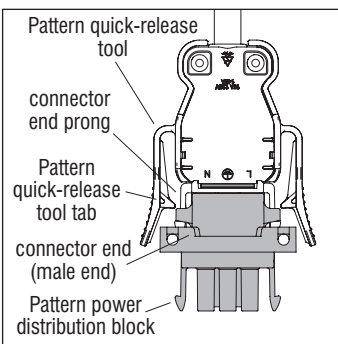

Detail C

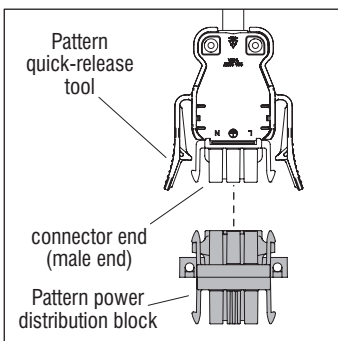

Detail D

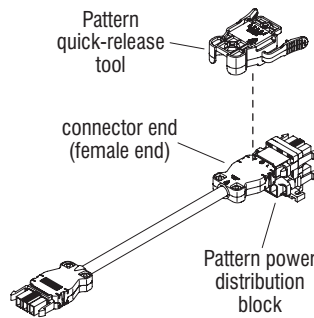

Figure 1

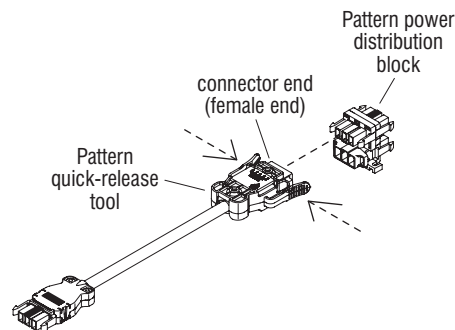

Figure 2

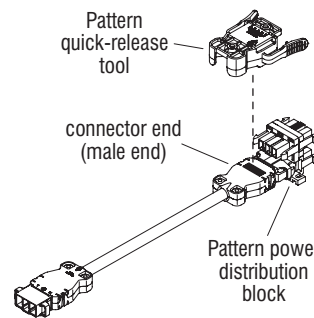

Figure 3

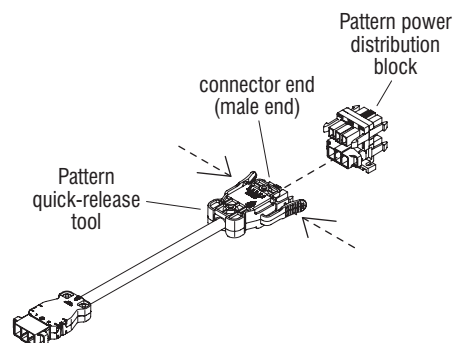

Figure 4

Pattern Quick-Release Tool

Note: The Pattern quick-release tool is a simple tool, designed to help remove the power infeed, power jumper & power module connector ends from the Pattern power distribution blocks. If on initial installation, or if the Pattern electrical system needs to be reconfigured due to table rearrangements, reference the following sections below based on the connectors that need to be removed.

Female Connector End

1. Snap the Pattern quick-release tool over the female end of the power module or power jumper connector end attached to the Pattern power distribution block (Figure 1).
2. The two Pattern quick-release tool tabs will align with the tabs of the Pattern power distribution block prongs. Squeeze the two Pattern quick release tool tabs together to push the two Pattern power distribution block tabs together, then pull the connector end out of the distribution block. Remove the quick-release tool from the connector end (Figure 2 & Details A & B).

Male Connector End

1. Snap the Pattern quick-release tool over the male end of the power infeed or power jumper connector end attached to the Pattern power distribution block (Figure 3).
2. The two Pattern quick-release tool tabs will align at the bottom of the connector end prongs. Squeeze the two Pattern quick release tool tabs together to push the two Pattern power distribution block prongs together, then pull the connector end out of the distribution block. Remove the quick-release tool from the connector end (Figure 4 & Details C & D).

KI
1330 Bellevue Street
Green Bay, Wisconsin 54302
1-800-424-2432
www.ki.com

KI is a registered trademark
of Krueger International, Inc.

© 2024 Krueger International, Inc.
All Rights Reserved
Code KI-AI-000129/KI/PDF/0424

