

METALWORKS™ Torsion Spring Interior and Exterior smooth texture



SUSTAIN™
High Performance
Sustainable
Ceiling Systems



FAST 134
Select Items Ship Fast
armstrongceilings.com/fast134



CAD/Revit® drawings at:
armstrongceilings.com/cadrevit

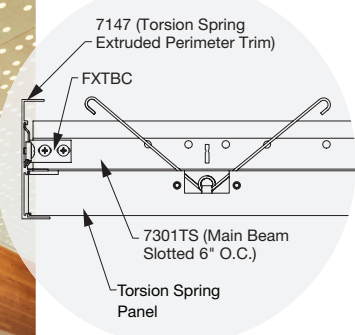

48" x 48" MetalWorks Torsion Spring panels with custom Effects™ finish and custom perforation pattern

CREATE!™
CUSTOM PERFORATIONS



armstrongceilings.com/
metalworkscustom

MetalWorks™ Torsion Spring panels provide a monolithic visual with a unique hide-the-grid installation with 100% swing-down accessibility.

KEY SELECTION ATTRIBUTES

- Four new Sequels™ pre-coat, wood-look finishes are part of the FAST134 program, including downlight panels
- Seventeen standard Effects™ wood-look finishes offer design options in bold, subtle, and classic woodgrain looks
- Natural Reflections laminate finishes provide superior wood-look visual with printed vinyl bonded to aluminum, now Class A and Canadian fire tested; visuals other than the ones shown are also available
- Sustainable Beyond Standard: Select standard and custom panels are part of the Sustain™ portfolio, and meet the most stringent industry sustainability compliance standards today
- MetalWorks™ FASTPeel™ panels feature an easier-to-remove protective film
- Moz™ Classic Metal Collection now available as custom finish option
- CleanAssure™ family of products – includes disinfectable panels, suspension systems, and trim
- Select products included in the FAST134 program – ready to ship in 4 weeks or less
- Transform your images onto custom perforated MetalWorks™ Create!™ ceiling panels for a unique aesthetic plus acoustical performance
- Interior panels feature swing-down accessibility
- Exterior options available in 24 x 24 x 1-1/2" and 24 x 48 x 1-1/2" standard panel sizes
- NRC values up to 0.90 with fiberglass infill panels (select perforation patterns)
- Washable and impact-, scratch-, and soil-resistant

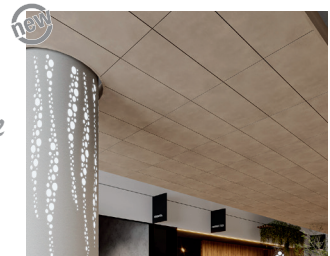

*Now available
with Moz
finishes!*

Add unique combinations of Moz grain designs and finishes for a one-of-a-kind visual on standard Torsion Spring panels.

METALWORKS™ Torsion Spring Interior and Exterior smooth texture



LEED WELL LBC

15% RECYCLED CONTENT

For LEED contribution contact TechLine

energy management	construction waste mgmt	regional materials	design for flexibility	EPD	recyclable/producer resp.	biobased materials	recycled content	sourcing of raw materials	material ingredient reporting	low emitting materials	lighting quality	acoustics
<input checked="" type="checkbox"/>	<input checked="" type="checkbox"/>	<input checked="" type="checkbox"/>	<input checked="" type="checkbox"/>	<input checked="" type="checkbox"/>	<input checked="" type="checkbox"/>	<input checked="" type="checkbox"/>	<input checked="" type="checkbox"/>	<input checked="" type="checkbox"/>	<input checked="" type="checkbox"/>	<input checked="" type="checkbox"/>	<input checked="" type="checkbox"/>	<input checked="" type="checkbox"/>

LOCATION DEPENDENT

STANDARD COLORS & FINISHES Due to printing limitations, shade may vary from actual product.

Painted

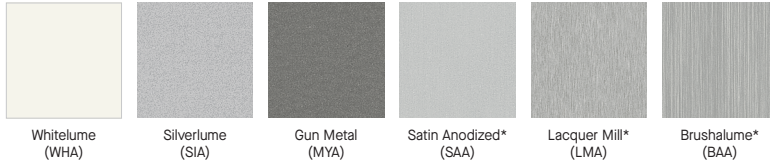

Sequels™ Pre-coated Coil, Fast Lead Time



**Natural Reflections (Interior Only)
Sustainable Laminate Finishes**

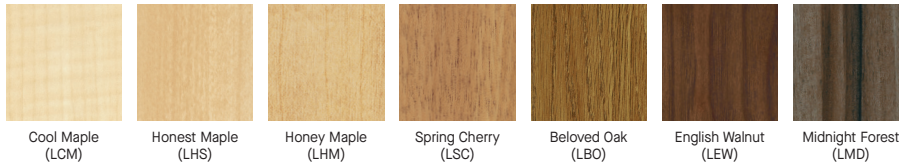

Effects™ Classic Dye-Sublimation



Effects™ Bold Dye-Sublimation



Effects™ Subtle Dye-Sublimation



*Not part of the Sustain™ portfolio
Sequels finishes for exterior: Available in M1 only on item 7225, and unavailable on item 7226.
Effects finishes are standard in 24" x 48" panels in M1 and M16.
Natural Reflections available for exterior applications as a custom option.

STANDARD PERFORATION OPTIONS (1:2 scale shown)

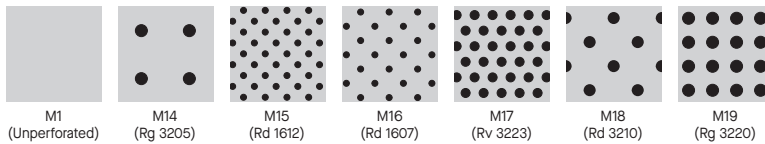

CUSTOM COLORS & FINISHES Due to printing limitations, shade may vary from actual product.

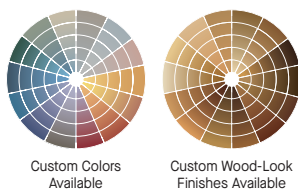

For custom options contact ASQuote,
ASQuote@armstrongceilings.com

PERFORATION OPTIONS

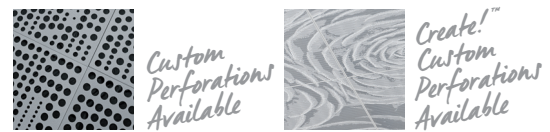

METALWORKS™ Torsion Spring
Interior and Exterior
smooth texture



24" x 48" MetalWorks Torsion Spring ceiling with custom Moz Classic Light Khaki finish and Moz Backlit Laser Cut Columns on Fog grain

Moz™ Classic Metal Collection

With over 30 years of custom fabrication experience, Moz™ is a one-stop-shop providing turnkey solutions to your design challenges.

Moz Classic Metal Collection is now available as custom on standard MetalWorks Torsion Spring panels for a one-of-a-kind visual. Contact ASQuote@armstrongceilings.com for details.

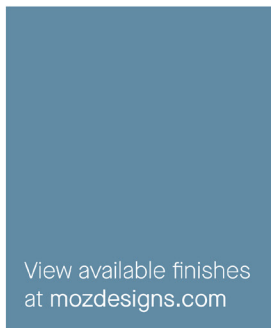

Pick Your Color



Pick Your Grain



Transform Your Ceiling

NOTE: Moz Classic Metal Finishes are hand applied and create a one-of-a-kind visual in your ceiling. Due to the unique grain application, panel-to-panel variation will occur.

TechLine 877 276-7876
armstrongceilings.com/metalworkstorsionspring

Armstrong®
World Industries

METALWORKS™ Torsion Spring Interior and Exterior smooth texture

SUSTAIN™
High Performance Sustainable Ceiling Systems
Declare.

LEED® WELL | LBC

15% RECYCLED CONTENT

- energy management
- construction waste mgmt
- regional materials
- design for flexibility
- EPD
- recyclable/producer resp.
- biobased materials
- recycled content
- sourcing of low materials
- material ingredient reporting
- low emitting materials
- lighting quality
- acoustics

For LEED contribution contact TechLine

- recycled content
- sourcing of low materials
- material ingredient reporting
- low emitting materials
- lighting quality
- acoustics

LOCATION DEPENDENT

VISUAL SELECTION Contact ASOrder@armstrongceilings.com for custom options.

Item No. ♦	Dimensions (Inches) W x L x H Custom Sizes Available
METALWORKS™ Torsion Spring Interior Panels Square 15/16"	
7209_-----	24 x 24 x 1-1/2"
7210_-----	24 x 48 x 1-1/2"
7211_-----	24 x 72 x 1-1/2"
7212_-----	24 x 96 x 1-1/2"
7213_-----	30 x 30 x 1-1/2"
Other Size Panels	W: 6" – 24" L: Up to 96" in 6" increments
	W: 30" – 48" L: Up to 48" in 6" increments (Aluminum will be 0.060" thick)
Exterior Panels Square 15/16"	
7225_-----	24 x 24 x 1-1/2"
7226_-----	24 x 48 x 1-1/2"



FAST134 program items ready to ship from manufacturer in 4 weeks or less. Up-to-date lead times and product options (sizes and colors) at armstrongceilings.com/fast134

♦ When specifying or ordering, include the appropriate perforation and color suffix with the item number (e.g., 7209 M 1 4 L M A).
* Light reflectance is for unperforated Whitelume.

PERFORMANCE Dots represent high level of performance.

Fire Performance	Light Reflect*	Springs per Panel	CleanAssure™ Disinfectable Panels		
			Fog	Spray	Wipe
Class A	0.75	4	*	*	*
Class A	0.75	4	*	*	*
Class A	0.75	6	*	*	*
Class A	0.75	6	*	*	*
Class A	0.75	4	*	*	*
Class A	0.75	Varies	*	*	*
Class A	0.75	Varies	*	*	*
Class A	0.75	4	*	*	*
Class A	0.75	4	*	*	*

ACOUSTICAL INFORMATION

Perforation		NRC with acoustical fleece	NRC with 1" fiberglass infill ††
M1†	Unperforated	N/A	N/A
M14†	Rg 3205	0.55	0.85
M15	Rd 1612	0.70	0.90
M16	Rd 1607	0.70	0.80
M17†	Rv 3223	0.75	0.90
M18†	Rd 3210	0.65	0.85
M19††	Rg 3220	0.75	0.90

† Available for exterior applications
†† Maximum NRC achieved with acoustical infill (Item 8200T10 or 5823).

For infill panel information, visit armstrongceilings.com/mwaccessories

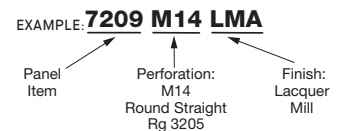

PHYSICAL DATA

Material

All panels, except 7226: Aluminum – 0.040"
7226: Aluminum – 0.063"

Surface Finish

Painted: Factory-applied polyester paint
Effects: Powder-coated, dye-sublimation, post-production Sequels: Pre-coated coil
Natural Reflections: PVC-free laminates
Custom colors and finishes available.

Custom Sequels finishes are available for orders 10,000 SF or larger.

Custom Moz™ finishes consist of a three-step manufacturing process: A graining process followed by a color application and then a final top coat.

Contact AS Quote for custom size and perforation options.

Fire Performance

Painted, Effects, Natural Reflections and Sequels finishes: Class A: ASTM E84, Flame Spread Index 25 or less. Smoke Developed Index 50 or less.

Natural Reflections Finishes: CAN/ULC S102: Flame Spread Rating 30. Smoke Developed Classification 30.

Painted aluminum finishes: CAN/ULC S102: Flame Spread Rating 25 or less. Smoke Developed Classification 50 or less.

Custom Moz finishes do not have ASTM E84 or CAN/ULC S102 testing. Please contact TechLine for project-specific assistance.

ASTM E1264 Classification

Painted, Effects, Natural Reflections and Sequels finishes: Unperforated: ASTM E1264 Type XX Pattern G Fire Class A
Perforated: ASTM E1264 Type XX Pattern C Fire Class A

Acoustical Options

Perforated panels are supplied with a black fiberglass fleece to absorb sound.

Recycled Content

Up to 15%.

Design Considerations

Anodized, Lacquer Mill and pre-coat finishes may vary in shade between production runs as well as over time. Sizes can be mixed and matched on non-perforated panels only.

30" x 30" panels have a directional finish that is perpendicular to the main beams; all other panel sizes have a directional finish that is parallel to the main beams.

MetalWorks steel and aluminum panels are made at different manufacturing facilities that use different paint systems. Because of this, similar colors, i.e., White and Whitelume, are not exact color matches. Please consider this when designing adjacent spaces with multiple MetalWorks products.

On pre-coated finishes, clarity of image is best on flat surfaces. Pattern repeat may occur. Product is dye-lotted. Due to potential color variation, be certain to order sufficient initial quantities and attic stock.

Installation Considerations

Panels with certain product finishes, e.g., Effects™ and Natural Reflections, are not MetalWorks™ FASTPeel™ panels and will be protected by other means for packaging and handling purposes.

Wind Uplift Performance

24" x 24", 24" x 48", and 24" x 72" panels noted for exterior flat applications tested for wind uplift Classes 30, 60, and 90. Specific installation instructions to meet these classes are available.

Design Support

For custom design assistance contact ProjectWorks® Design Services or visit armstrongceilings.com/projectworks

Seismic Restraint

MetalWorks Torsion Spring panels have been engineered, tested, and approved for application in all seismic areas when installed per Armstrong Ceilings installation instructions.

Cleaning and Disinfecting

Cleaning and CDC approved disinfecting options available on armstrongceilings.com/cleaning

FAST134 Program Considerations

Size of Job Matters: Big jobs, over 2500 SF or 50 pieces for shapes/vertical elements will have longer lead times.

Location Matters: Transit time not included. We are ready to ship in one week on FAST1 items. However, transit to the states west of Wyoming may add time.

Distributor Truck Schedule Matters: We rely on distribution to help move products around the country. When speed matters, work with your local distributor to ensure FAST134 service.

Stock vs Made-to-Order Matters: FAST3 & FAST4 items are made-to-order and will ship direct to distributor. FAST1 (stocked items) will go through distribution and depend on distributor truck schedules.

Warranty

One (1) year limited warranty.
Details at armstrongceilings.com/warranty

Weight

0.69 lbs/SF
0.86 lbs/SF (Item 7226)

METALWORKS™ Torsion Spring Interior and Exterior Installation Details



Declare.

LEED WELL LBC

- 15% RECYCLED CONTENT
- energy management
- construction waste mgmt
- regional materials
- design for flexibility
- EPD
- recyclable/extended producer resp.
- biobased materials
- recycled content
- sourcing of raw materials
- material ingredient reporting
- low emitting materials
- lighting quality
- acoustics

For LEED contribution contact TechLine

LOCATION DEPENDENT

HOW TO INSTALL PANELS

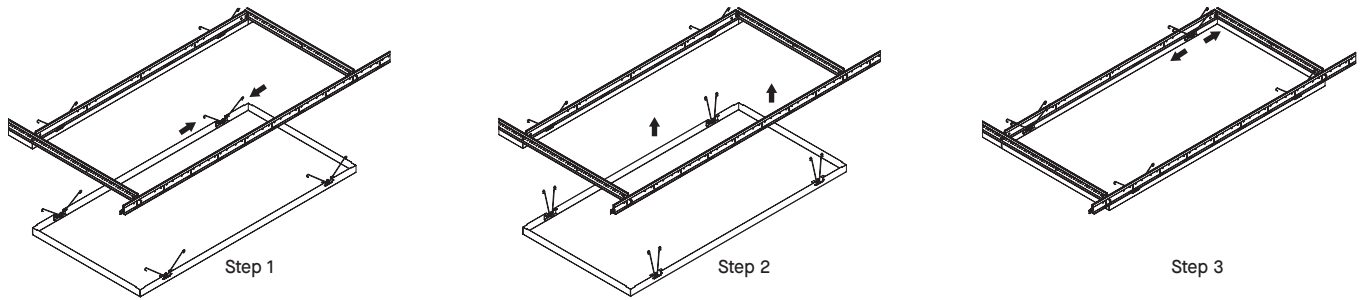

INTERIOR INSTALLATION DETAILS

For exterior details, consult the MetalWorks™ Exterior Torsion Spring installation instructions, BPLA-297922, on our website.

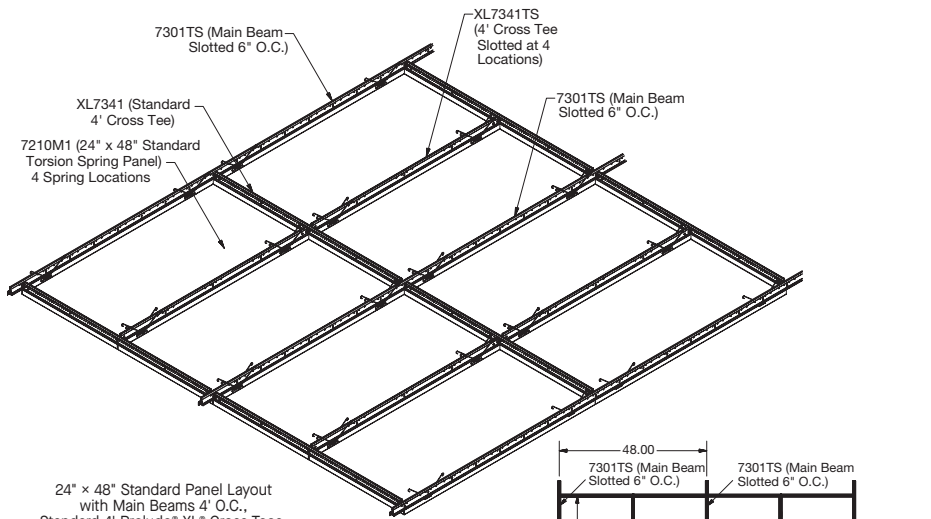

24" x 48" Standard Panel Layout with Main Beams 4' O.C., Standard 4' Prelude® XL® Cross Tees, 4' Slotted Cross Tees

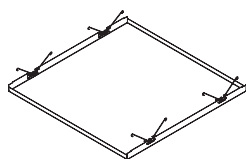
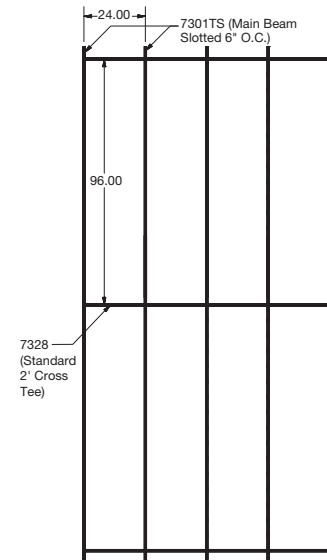
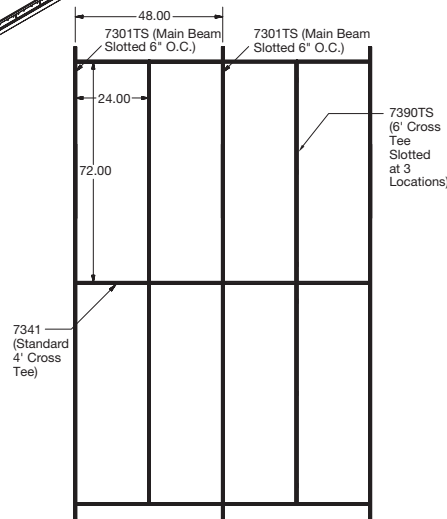
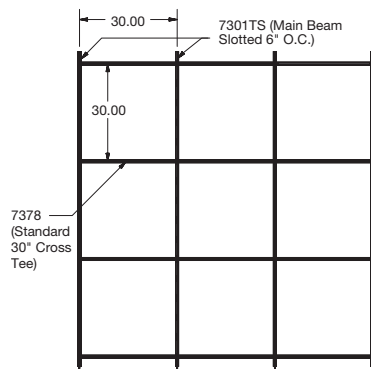

Suspension System Layout for 30" x 30" Panels

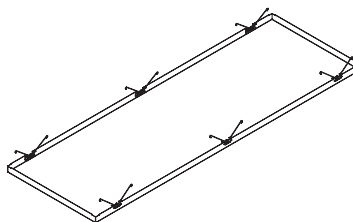

Suspension System Layout for 24" x 72" Panels

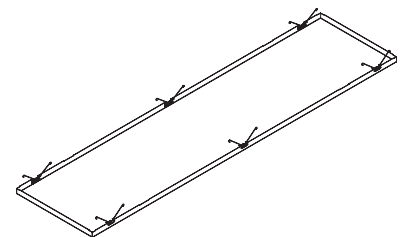

Suspension System Layout for 24" x 96" Panels

METALWORKS™ - Standard



METALWORKS™ Torsion Spring Interior and Exterior Perimeter Details



LEED WELL LBC

15% RECYCLED CONTENT

- energy management
- construction waste mgmt
- regional materials
- design for flexibility
- EPD
- recyclable/producer resp.

For LEED contribution contact TechLine

- biobased materials
- recycled content
- sourcing of low materials
- material ingredient reporting
- low emitting materials
- lighting quality
- acoustics

LOCATION DEPENDENT

INTERIOR WALL PERIMETER DETAILS – For exterior details, consult the MetalWorks™ Torsion Spring Exterior installation instructions, BPLA-297922, on our website.

Installation Detail – Wall Perimeter

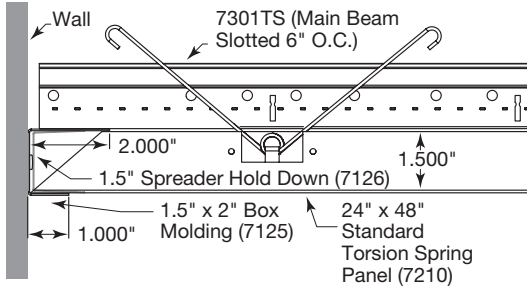

DISCONTINUOUS SYSTEM PERIMETER DETAILS

Installation Detail – Extruded Perimeter Trim #7147

Recommended for use with both Sequels™ and Natural Reflections finishes. Available in Effects™ as custom finish.

Full Panels

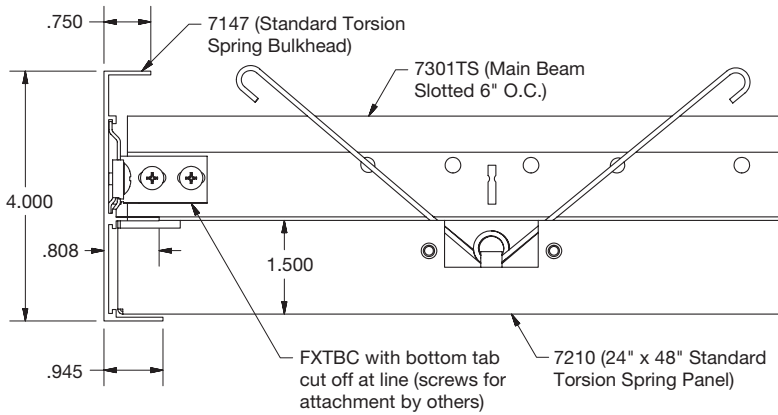

Cut Panels

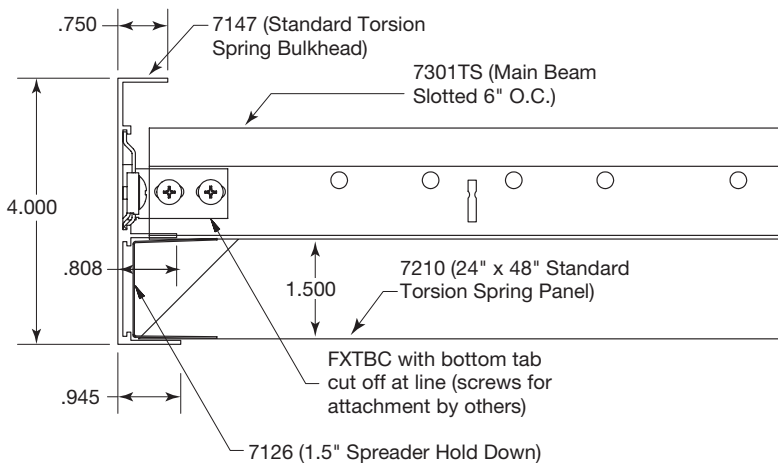

Installation Detail – Formed Perimeter Trim #7131

Recommended for use with LMA, BAA, and SAA finishes.

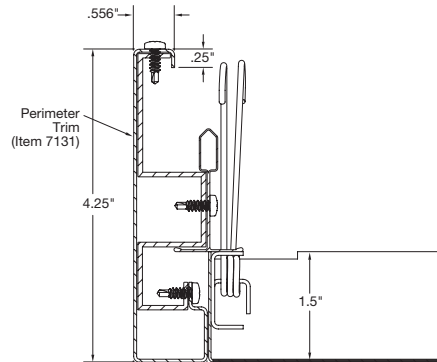

METALWORKS™ Torsion Spring Interior and Exterior Installation Details



Declare.



For LEED contribution contact TechLine



LOCATION DEPENDENT

ACCESSORIES

	Item No. ♦	Description	Dimensions (Inches) Nominal W × L × H	Color	Pieces/ Carton
Wall-to-Wall Installs	7125_ _ _	Box Molding	2 × 96 × 1-1/2"	WHA, SIA, MYA, SAA, LMA, BAA, BL Black is recommended for Sequels™ and Natural Reflections panel finishes Available in Effects™ panel as custom finish	10
	7147_ _	Torsion Spring Perimeter Trim (Extruded)	1 × 120 × 4"	WH, SG, MY, BL* Black is recommended for Sequels™ and Natural Reflections panel finishes Available in Effects™ panel as custom finish	6
	7131_ _ _	Torsion Spring Perimeter Trim (Formed)	1 × 96 × 4-1/4"	LMA, BAA, SAA	6
Acoustical Infill Panels	5823	BioAcoustic™ Infill Panel	24 × 24 × 5/8"	Black	12
	8200T10	1" Fiberglass Infill Bag	24 × 24 × 1"	Black (Gloss)	12
Other Accessories	7129	Torsion Spring Hook Access Tool	N/A	N/A	1
	7130	Torsion Spring Suction Access Tool	N/A	N/A	1
	7126	Spreader Hold Down	1 × 10-5/8 × 1-1/2"	N/A	50

♦ When specifying or ordering, include the appropriate color code with the item number (e.g. 7131 L M Δ)
* Coordinates with WHA, SIA, MYA Torsion Spring panel finishes

SUSPENSION SYSTEMS

	Item No.	Description	Dimensions (Inches)
15/16" Prelude® XL® Suspension System Some items slotted for Torsion Spring.	7301TS	Prelude XL 12' HD Main Beam – slotted for Torsion Spring	144 × 15/16 × 1-11/16"
	XL7341TS	Prelude XL 4' Cross Tee – slotted for Torsion Spring	48 × 15/16 × 1-11/16"
	XL7390TS	Prelude XL 6' Cross Tee – slotted for Torsion Spring	72 × 15/16 × 1-11/16"
	XL7378	Prelude XL 30" Cross Tee	30 × 15/16 × 1-3/8"
	XL8320	Prelude XL 2' Cross Tee	24 × 15/16 × 1-11/16"
	XL7341	Prelude XL 4' Cross Tee	48 × 15/16 × 1-11/16"
Exterior Suspension System 15/16" Prelude XL Some items slotted for Torsion Spring.	7301G90ATS	Prelude XL 12' HD Exterior Main Beam – slotted for Torsion Spring	144 × 15/16 × 1-11/16"
	XL7341G90ATS	Prelude XL 4' Exterior Cross Tee – slotted for Torsion Spring	48 × 15/16 × 1-11/16"
	XL7321G90A	Prelude XL 2' Exterior Cross Tee	24 × 15/16 × 1-11/16"



new LIGHTING SOLUTIONS
METALWORKS™ Torsion Spring
 Center-cut Panels for Recessed Downlighting
 smooth texture



MetalWorks Torsion Spring center-cut downlight panels in Sequels – New Haven Walnut

Pre-cut durable, metal ceiling panels are designed to seamlessly integrate with trimless downlights. Perfectly centered fixtures, perfectly cut tiles—every time.

KEY SELECTION ATTRIBUTES

- Perfectly centered USAI® Lighting fixtures for flush-fit visual
- Coordinating fixture colors available for all standard downlight finishes
- Time and labor savings solution – downlight fixtures are fully adjustable within the system so there is no cutting, no mess, and no need to remove panels
- Entire system helps contribute to healthier spaces, part of CleanAssure™ portfolio
- Clean, minimal trimless appearance in durable, factory-cut metal panels
- Pre-cut Torsion Spring panels available in FAST134 program
- Pre-engineered and tested for fit-and-finish in all seismic areas
- For offset factory-cut panels, contact ASQuote@armstrongceilings.com. Custom grid layouts are possible depending on lighting layout.



MetalWorks™ FASTPeel™ panels feature an easier-to-remove protective film



Now, Lighting Integration Made Easy

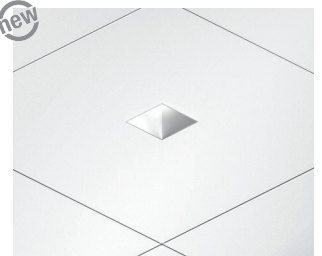

DOWNLIGHTING: MetalWorks Torsion Spring center cut panel with coordinating USAI Lighting trimless downlight fixture. Integration details at armstrongceilings.com/downlighting

COLORS Due to printing limitations, shades may vary from actual product.



Painted



Whitelume (WHA) Silverlume (SIA) Gun Metal (MYA)



Sequels™ Pre-coated Coil, Fast Lead Time



La Jolla Oak* (SQLO) New Haven Walnut* (SQNW) Cape May Cherry* (SQCC) Montauk Driftwood* (SQMD)

*Not part of the Sustain™ portfolio

PERFORATION OPTIONS

(1:2 scale shown)



M1 (Unperforated) M15 (Rd 1612) M16 (Rd 1607)





LIGHTING SOLUTIONS

METALWORKS™ Torsion Spring

Center Cut Panels for Recessed Downlighting
smooth texture

VISUAL SELECTION

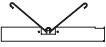
	MetalWorks Torsion Spring Panel Item No. ◆	Panel Description	USAI® Fixture Dimension (Nominal)	Coordinating USAI Fixture Family	Coordinating USAI Fixture Part No.	USAI Grid Mounting Bars Item No.
METALWORKS™ Torsion Spring 	7209__C03____	24 x 24 x 1-1/2"	3.5" Square Downlight	BeveLED® Mini for MetalWorks	B3SXP-UA	UA2
	7209__C04____	24 x 24 x 1-1/2"	5" Square Downlight	BeveLED® 2.2 for MetalWorks	B4SXP-UA	UA2
	7210__C03____	24 x 48 x 1-1/2"	3.5" Square Downlight	BeveLED Mini for MetalWorks	B3SXP-UA	UA2 or UA4
	7210__C04____	24 x 48 x 1-1/2"	5" Square Downlight	BeveLED 2.2 for MetalWorks	B4SXP-UA	UA2 or UA4
	7211__C03____	24 x 72 x 1-1/2"	3.5" Square Downlight	BeveLED Mini for MetalWorks	B3SXP-UA	UA2
	7211__C04____	24 x 72 x 1-1/2"	5" Square Downlight	BeveLED 2.2 for MetalWorks	B4SXP-UA	UA2
	7212__C03____	24 x 96 x 1-1/2"	3.5" Square Downlight	BeveLED Mini for MetalWorks	B3SXP-UA	UA2
	7212__C04____	24 x 96 x 1-1/2"	5" Square Downlight	BeveLED 2.2 for MetalWorks	B4SXP-UA	UA2
	7213__C03____*	30 x 30 x 1-1/2"	3.5" Square Downlight	BeveLED Mini for MetalWorks	B3SXP-UA	UA2
	7213__C04____*	30 x 30 x 1-1/2"	5" Square Downlight	BeveLED 2.2 for MetalWorks	B4SXP-UA	UA2



FAST134 program items ready to ship from manufacturer in 4 weeks or less.
Up-to-date lead times and product options (sizes and colors) at armstrongceilings.com/fast134

NOTE: Refer to lighting partner cut sheets for light location considerations.

- ◆ For Torsion Spring downlight item numbers, add the perforation following the base item number, and then add the 3- or 4-digit finish code. (ie: 7209 M 1 5 C 0 3 S 1 A)
- * Sequels™ finishes are a custom option on this size.

INSTALLATION DETAILS

MetalWorks Torsion Spring
24" x 24" Panel

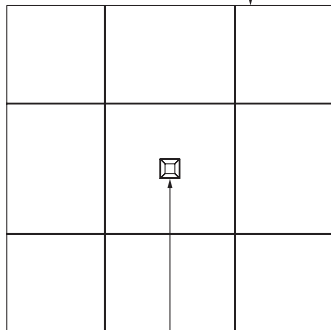

USAI BeveLED Mini
for MetalWorks – Item B3SXP-UA

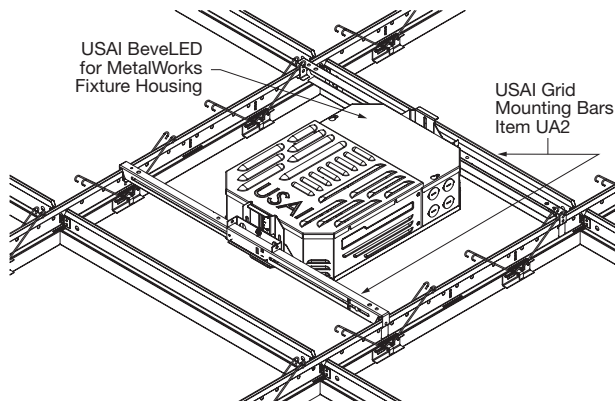

LIGHTING FIXTURES

Compatible with USAI Lighting BeveLED 2.2 and BeveLED Mini MetalWorks fixture families.

USAI® Lighting

For detailed lighting information, contact your local USAI representative or visit usailighting.com/metalworks for more information

TechLine 877 276-7876

armstrongceilings.com/metalworkstorsionspring

Armstrong®
World Industries