

FLIRT® MULTI-PURPOSE MEETING TABLES // DESIGNED BY 5D STUDIO

Please note that effective April 1st, 2025, a 4.5% tariff surcharge will be applied to the net subtotal on all orders.

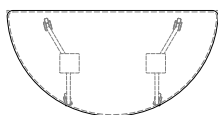

TABLE TOP FEATURES/SPECIFICATIONS:



Half-Round



Rectangle

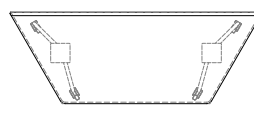

Trapezoid - Long Side

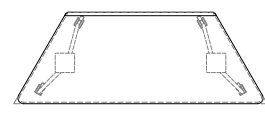

Trapezoid - Short Side

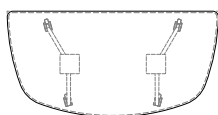

Radiused End

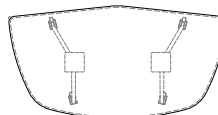

Video Conference End

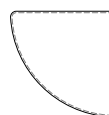

Corner

- » Fixed and flip-up tables available in half-round, rectangle, trapezoid, radiused end and video conference end top shape options.
- » Corner table is fixed only (for connecting purposes, no base attached). Connecting plates included.
- » Flip-up tables feature a single-lever release mechanism for quick and easy set-up and storage.
- » Table tops offered in maple, walnut and white oak veneer, as well as laminate and Fenix selections.
- » All standard wood finishes, excluding MA0915 Ebony Maple, available on selected wood species.
- » Premium wood finish upcharge applies to the following wood finishes. Refer to options section for pricing.
 - Super Matte Sable Maple
 - Alabaster Oak
 - Super Matte Sable Oak
- » For custom wood finishes, please add one-time upcharge of \$472 List per color per order.
- » Laminate tops available in all standard laminates.
- » For custom laminates, add \$590 List per color per order. Pre-approval required, please contact client services.
- » Unless specified, wood grain direction will run lengthwise on all tables.
- » Fenix offered in five standard colorways.

FENIX COLORS:

- » FJ0032 Bianco Kos
- » FJ0720 Nero Ingo
- » FJ0725 Grigio Efeso
- » FJ0718 Grigio Londra
- » FJ0724 Grigio Bromo

FLIRT® MULTI-PURPOSE MEETING TABLES // DESIGNED BY 5D STUDIO

TABLE EDGE FEATURES/SPECIFICATIONS:



- » All edges are 1" thick.
- » Eased and Beveled edge styles available on all tables.
- » Waterfall edge available on rectangle and trapezoid tables, in veneer or laminate finishes only (excludes Fenix). Offered on one or two sides, with Beveled edge featured on remaining sides.
- » Eased and Beveled edge finish will match veneer, standard wood grain or solid black laminate, and Fenix Nero Ingo (black) table top finish color, unless otherwise specified.
- » For all other standard solid color laminates and Fenix, Eased and Beveled edge will be natural exposed plywood with a clear coat finish, as standard.
- » For waterfall edge finish, laminate tops are post-formed to deliver a seamless finish from the top surface to the edge underside.

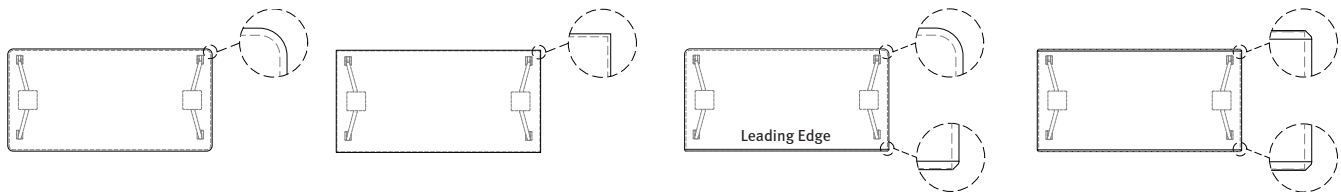

Beveled edge tables will have radiused corners

Eased edge tables will have 90-degree corners

One-sided waterfall edge tables will have 90-degree corner on leading edge and radiused corner on opposing side

Two-sided waterfall edge tables will have 90-degree corners on all sides

BASE FEATURES/SPECIFICATIONS:

- » Die-cast aluminum legs available in standard and premium metal finishes.
- » Interior leg column features removable cover for vertical wire management.
- » Mobile version standard with 4 locking chrome casters that are suitable for carpet and hard-surface floors.
- » Glides presented in chrome finish and are non-adjustable.
- » Non-skid glides available for hard-surface floors.
- » Fixed top tables 78" in length and greater, as well as all 42" high tables, feature a stretcher bar for added stability. Stretcher bar will match leg finish as standard, unless otherwise specified.
- » Edge mount bases are positioned 3" from table edge for additional leg space. Available on rectangle and trapezoid top shapes only.
- » Inset mount bases are positioned 15" from table edge to provide seating on all sides.

STANDARD METAL LEG FINISHES:

- » 0299 Polished Aluminum
- » 0405 Charcoal Grey
- » 0535 Metallic Silver
- » 0630 Satin Black

PREMIUM METAL LEG FINISHES:

- » 0605 Matte Black
- » 0705 Matte Cotton
- » 0788 Glossy Cotton
- » 0805 Oasis
- » 0905 Mint
- » 1005 Mercury
- » 1105 Canary
- » 1205 Stone
- » 1305 Sage
- » 1405 Ice Blue
- » 1505 Clay

CONNECTING TABLE MECHANISM FEATURES:

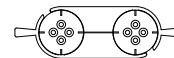
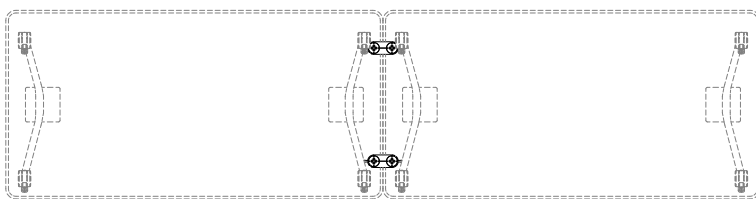

Ganging mechanism, locked
(2 units above are included per set).

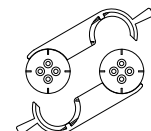

Ganging mechanism, unlocked.

- » Ordered separately, ganging mechanism comes two per set to connect two tables together (end-to-end, side-to-side, end-to-side, etc.).
- » Please include layout drawings or sketch with each order to ensure proper ganging bracket placement location.

FLIRT® MULTI-PURPOSE MEETING TABLES // DESIGNED BY 5D STUDIO

MODESTY PANEL PRODUCT FEATURES:

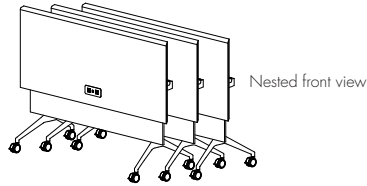

Nested front view

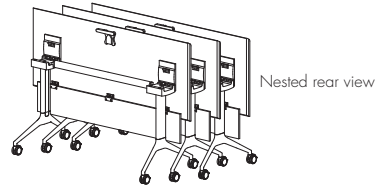

Nested rear view

- » 8" high x $\frac{1}{2}$ " thick panels available on fixed or flip-up rectangle and trapezoid tables.
- » Offered in maple, walnut and white oak, in all standard and custom wood finishes, as well as laminate and Fenix selections.
- » Panels specified with veneer, standard wood grain or solid black laminate, and Fenix Nero Ingo (black), edge finish will match, unless otherwise specified.
- » Panels specified with all other standard solid color laminates and Fenix options, edge finish will be natural exposed plywood with a clear coat finish, as standard.
- » Finish is applied to both sides of modesty panel.
- » Panels flip downward when applied to flip-up tables to maintain nesting capability.
- » In-field installation required.

POWER UNITS:

- » Available on all flip-up and fixed tables, excluding corner connecting tables.
- » Black or white finish with 120" electrical cord (no hardwire option available for this series).
- » UL listed.



PX3
5 $\frac{7}{8}$ " W x 2 $\frac{7}{8}$ " D
One outlet, one USB-A and one USB-C charging port

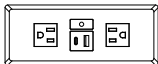

PX4
7 $\frac{1}{4}$ " W x 2 $\frac{7}{8}$ " D
Two outlets, one USB-A and one USB-C charging port

- » Clips for horizontal wire management affixed to underside of table tops for convenient accessibility (included only when power is specified).
- » **For daisy chain requirements and pricing, please refer to pages 6-8.**

ORDERING REQUIREMENTS:

- » Model number
- » Wood species
- » Wood finish
- » Edge detail
- » Leg placement
- » Metal leg finish
- » Options, as applicable

FLIRT® MULTI-PURPOSE MEETING TABLES // DESIGNED BY 5D STUDIO

POWER UNIT STANDARD LOCATIONS (FOR CUSTOM PLACEMENT, PLEASE CONTACT CLIENT SERVICES):

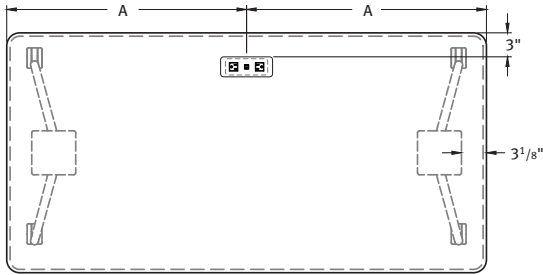

Rectangle Table - 1 Power Unit

LENGTH	A
48"	24"
60"	30"
66"	33"
72"	36"
78"	39"
84"	42"

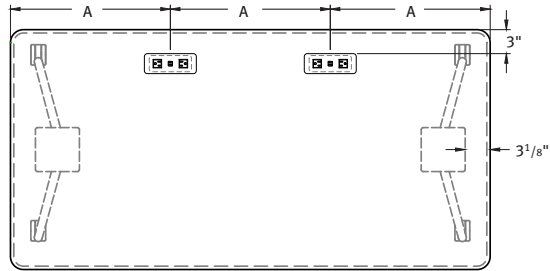

Rectangle Table - 2 Power Units

LENGTH	A
48"	16"
60"	20"
66"	22"
72"	24"
78"	26"
84"	28"

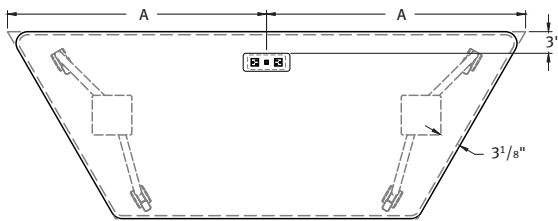

Trapezoid Table, Long Side - 1 Power Unit

LENGTH	A
48"	24"
60"	30"
72"	36"

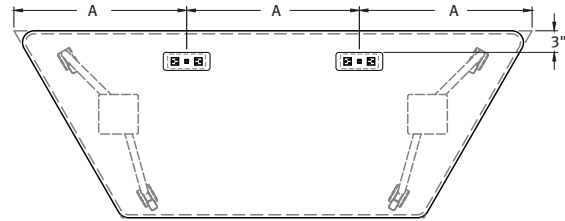

Trapezoid Table, Long Side - 2 Power Units

LENGTH	A
48"	16"
60"	20"
72"	24"

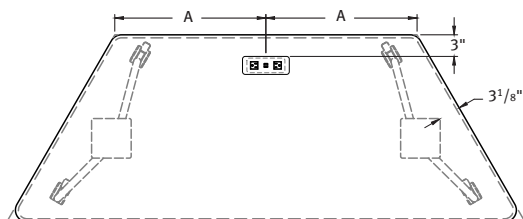

Trapezoid Table, Short Side - 1 Power Unit

LENGTH	A
48"	12"
24" x 60"	18"
30" x 60"	15"
72"	21"

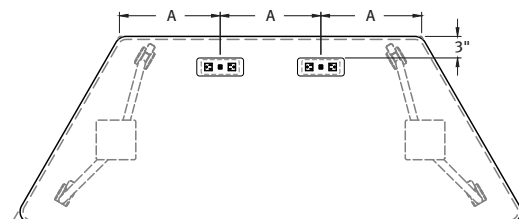

Trapezoid Table, Short Side - 2 Power Units

LENGTH	A
48"	8"
24" x 60"	12"
30" x 60"	10"
72"	14"

FLIRT® MULTI-PURPOSE MEETING TABLES // DESIGNED BY 5D STUDIO

POWER UNIT STANDARD LOCATIONS (FOR CUSTOM PLACEMENT, PLEASE CONTACT CLIENT SERVICES):

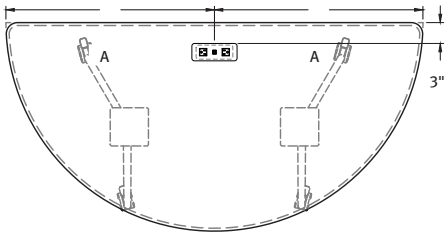

Half-Round Table - 1 Power Unit

LENGTH	A
48"	24"
60"	30"
72"	36"

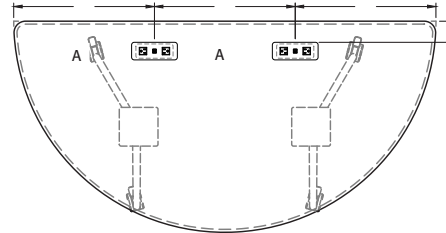

Half-Round Table - 2 Power Units

LENGTH	A
48"	16"
60"	20"
72"	24"

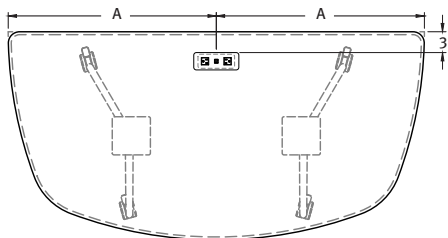

Radiused End Table - 1 Power Unit

LENGTH	A
48"	24"
60"	30"
72"	36"

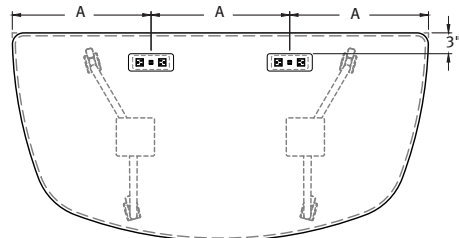

Radiused End Table - 2 Power Units

LENGTH	A
48"	16"
60"	20"
72"	24"

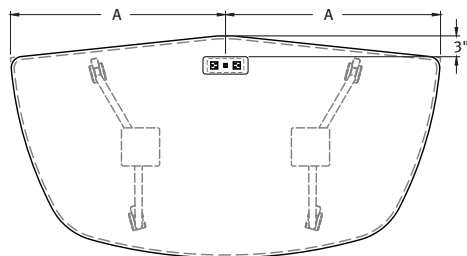

Video Conference End Table - 1 Power Unit

LENGTH	A
48"	25"
60"	31"
72"	37"

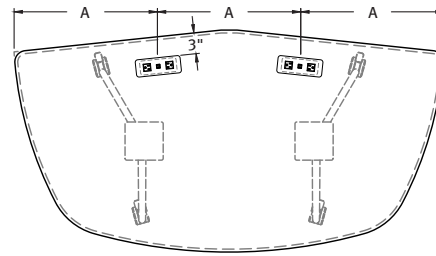

Video Conference End Table - 2 Power Units

LENGTH	A
48"	16.67"
60"	20.67"
72"	24.67"

FLIRT® MULTI-PURPOSE MEETING TABLES // DESIGNED BY 5D STUDIO

GROMMET:



- » Available on all flip-up and fixed tables, excluding corner connecting table.
- » Dimensions: 2" outer diameter x 1⁵/₈" inner diameter x 5⁵/₈" deep.
- » 5⁵/₈" cord slot.
- » Available in black and chrome finishes.
- » Please specify location on table surface.

DAISY CHAIN ELECTRICAL SPECIFICATIONS:

- » Daisy chain units are required for end-to-end or ganging connections, as well as when two electrical units are specified on one top.
- » To determine jumper cable length, measure length from edge of electrical unit to end of table.
- » Every connection point must be a female-to-male or male-to-female connection (all daisy chain power units feature male ends).
- » **Ganging connectors are required for all daisy chain applications.**
- » Note: Always disconnect cables prior to separating tables.

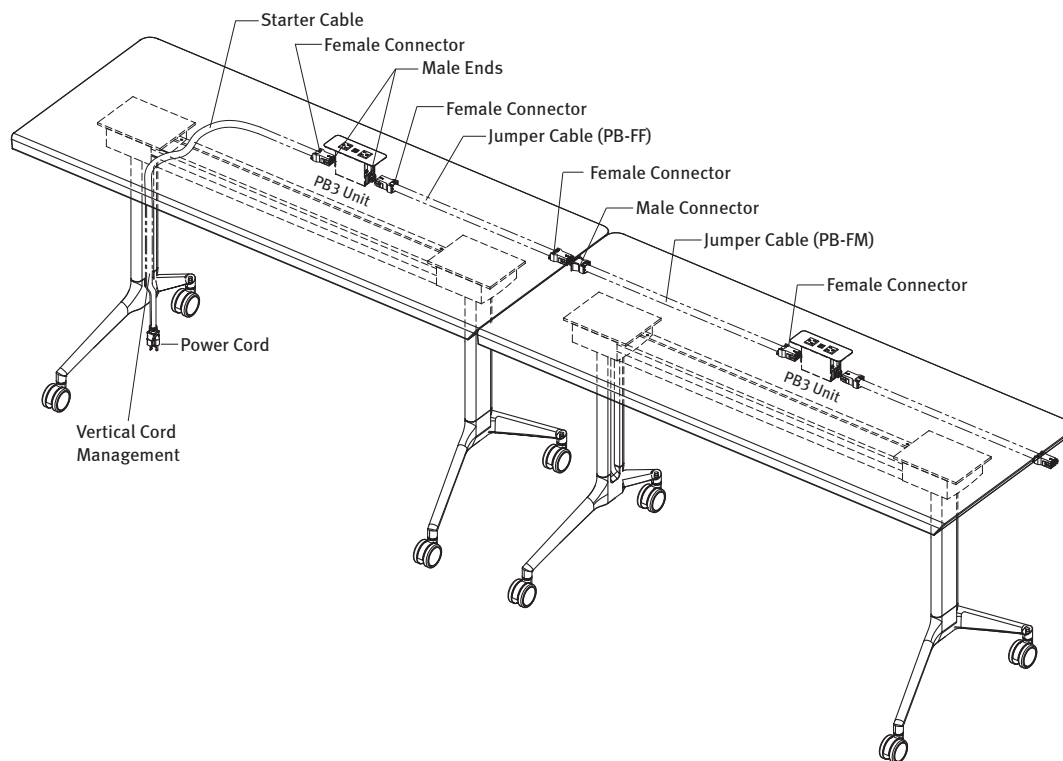



FLIRT® MULTI-PURPOSE MEETING TABLES // DESIGNED BY 5D STUDIO

ELECTRICAL UNIT NOTES:

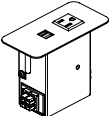
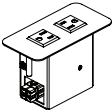
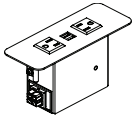
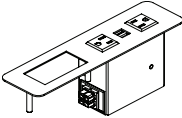
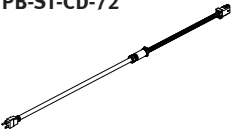
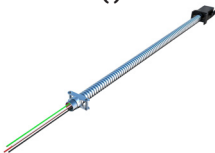
- » **Ganging connectors are required for all daisy chain applications.**
- » **Note: Power bands with daisy chain feature male ends.**

MODEL NUMBER	PRODUCT SPECIFICATIONS	LIST												
PB1-DC 	Power Band 1 Daisy Chain <ul style="list-style-type: none"> » Dimensions: 5³/₄" W x 2¹/₂" D » Metallic silver or white finish » Unit features one simplex outlet and two USB charging ports. » UL listed 	609												
PB2-DC 	Power Band 2 Daisy Chain <ul style="list-style-type: none"> » Dimensions: 5³/₄" W x 2¹/₂" D » Metallic silver or white finish » Unit features two simplex outlets » UL listed 	428												
PB3-DC 	Power Band 3 Daisy Chain <ul style="list-style-type: none"> » Dimensions: 6¹/₂" W x 2¹/₂" D » Metallic silver or white finish » Unit features two simplex outlets and two USB charging ports » UL listed 	640												
PB4-DC 	Power Band 4 Daisy Chain <ul style="list-style-type: none"> » Dimensions: 10¹/₂" W x 2¹/₂" D » Metallic silver or white finish » Unit features two simplex outlets, two USB charging ports and cut-out for an A/V faceplate » For available A/V faceplate options, please contact client services » UL listed 	701												
PB-ST-CD-72 	Power Band Starter Cable, 72" Long, Corded Plug Infeed <ul style="list-style-type: none"> » Must select either corded or hardwire starter cable which goes from power source in wall or floor to first power band unit 	276												
PB-ST-HW-() 	Power Band Starter Cable, Hardwire Infeed <ul style="list-style-type: none"> » Must select either corded or hardwire starter cable which goes from power source in wall or floor to first power band unit <table border="1"> <thead> <tr> <th>MODEL</th> <th>LENGTH</th> <th>LIST</th> </tr> </thead> <tbody> <tr> <td>PB-ST-HW-72</td> <td>72"</td> <td>191</td> </tr> <tr> <td>PB-ST-HW-108</td> <td>108"</td> <td>220</td> </tr> <tr> <td>PB-ST-HW-120</td> <td>120"</td> <td>245</td> </tr> </tbody> </table>	MODEL	LENGTH	LIST	PB-ST-HW-72	72"	191	PB-ST-HW-108	108"	220	PB-ST-HW-120	120"	245	SEE TABLE
MODEL	LENGTH	LIST												
PB-ST-HW-72	72"	191												
PB-ST-HW-108	108"	220												
PB-ST-HW-120	120"	245												

FLIRT® MULTI-PURPOSE MEETING TABLES // DESIGNED BY 5D STUDIO

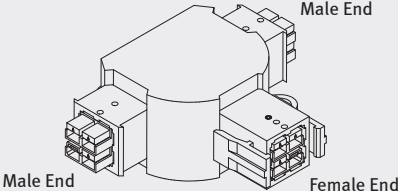
MODEL NUMBER	PRODUCT SPECIFICATIONS	LIST																											
<p>PB-FF-()</p> 	<p>Power Band Jumper Cables, Female to Female</p> <ul style="list-style-type: none"> » Typically used to connect 2 units together » For additional lengths in 12" increments, please add \$21 List per foot <table border="1" data-bbox="467 814 792 1087"> <thead> <tr> <th>MODEL</th> <th>LENGTH</th> <th>LIST</th> </tr> </thead> <tbody> <tr><td>PB-FF-12</td><td>12"</td><td>130</td></tr> <tr><td>PB-FF-24</td><td>24"</td><td>142</td></tr> <tr><td>PB-FF-30</td><td>30"</td><td>154</td></tr> <tr><td>PB-FF-36</td><td>36"</td><td>154</td></tr> <tr><td>PB-FF-48</td><td>48"</td><td>166</td></tr> <tr><td>PB-FF-54</td><td>54"</td><td>172</td></tr> <tr><td>PB-FF-60</td><td>60"</td><td>179</td></tr> <tr><td>PB-FF-72</td><td>72"</td><td>191</td></tr> </tbody> </table>	MODEL	LENGTH	LIST	PB-FF-12	12"	130	PB-FF-24	24"	142	PB-FF-30	30"	154	PB-FF-36	36"	154	PB-FF-48	48"	166	PB-FF-54	54"	172	PB-FF-60	60"	179	PB-FF-72	72"	191	SEE TABLE
MODEL	LENGTH	LIST																											
PB-FF-12	12"	130																											
PB-FF-24	24"	142																											
PB-FF-30	30"	154																											
PB-FF-36	36"	154																											
PB-FF-48	48"	166																											
PB-FF-54	54"	172																											
PB-FF-60	60"	179																											
PB-FF-72	72"	191																											
<p>PB-FM-()</p> 	<p>Power Band Jumper Cables, Female to Male</p> <ul style="list-style-type: none"> » Typically used to connect 2 units together » For additional lengths in 12" increments, please add \$21 List per foot <table border="1" data-bbox="467 1302 792 1575"> <thead> <tr> <th>MODEL</th> <th>LENGTH</th> <th>LIST</th> </tr> </thead> <tbody> <tr><td>PB-FM-12</td><td>12"</td><td>130</td></tr> <tr><td>PB-FM-24</td><td>24"</td><td>142</td></tr> <tr><td>PB-FM-30</td><td>30"</td><td>154</td></tr> <tr><td>PB-FM-36</td><td>36"</td><td>154</td></tr> <tr><td>PB-FM-48</td><td>48"</td><td>166</td></tr> <tr><td>PB-FM-54</td><td>54"</td><td>172</td></tr> <tr><td>PB-FM-60</td><td>60"</td><td>179</td></tr> <tr><td>PB-FM-72</td><td>72"</td><td>191</td></tr> </tbody> </table>	MODEL	LENGTH	LIST	PB-FM-12	12"	130	PB-FM-24	24"	142	PB-FM-30	30"	154	PB-FM-36	36"	154	PB-FM-48	48"	166	PB-FM-54	54"	172	PB-FM-60	60"	179	PB-FM-72	72"	191	SEE TABLE
MODEL	LENGTH	LIST																											
PB-FM-12	12"	130																											
PB-FM-24	24"	142																											
PB-FM-30	30"	154																											
PB-FM-36	36"	154																											
PB-FM-48	48"	166																											
PB-FM-54	54"	172																											
PB-FM-60	60"	179																											
PB-FM-72	72"	191																											
<p>PB-T</p> 	<p>Power Band T-Connector</p> <ul style="list-style-type: none"> » Used when power is needed to go in two directions » Features 2 male ends and 1 female end 	172																											

FLIRT® MULTI-PURPOSE MEETING TABLES // DESIGNED BY 5D STUDIO

RECTANGLE TABLE NESTING DIMENSIONS (BASED ON 66" TABLE LENGTH):

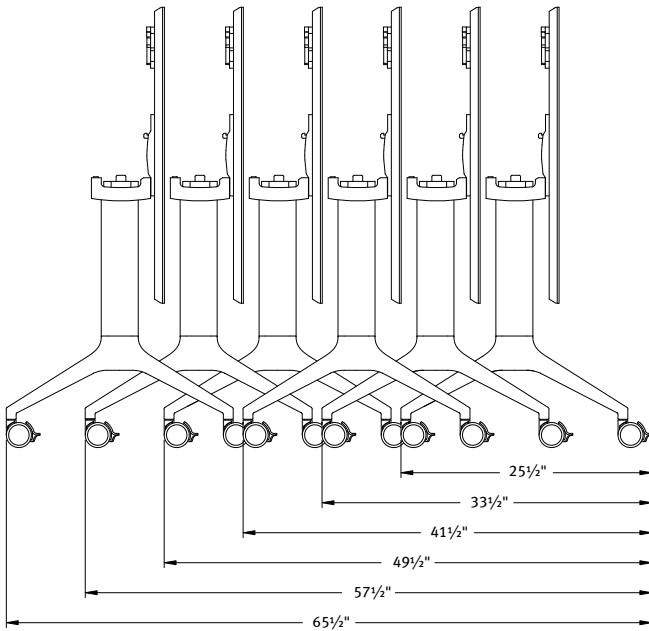
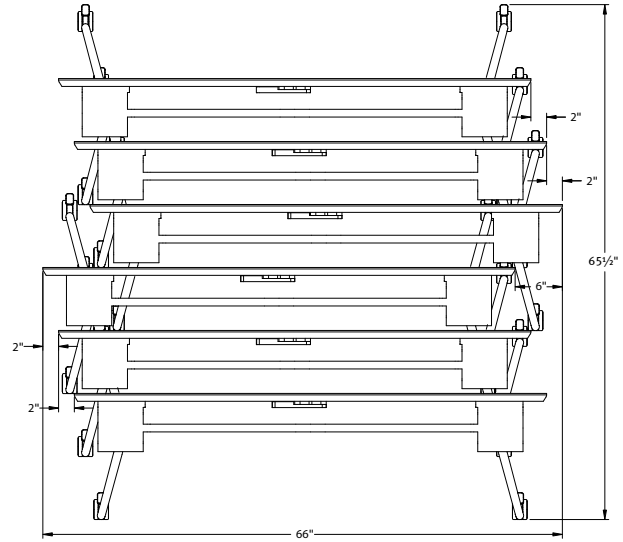
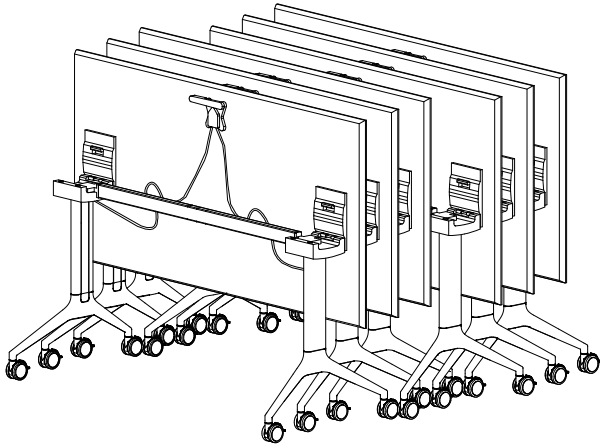

FLIRT® MULTI-PURPOSE MEETING TABLES // DESIGNED BY 5D STUDIO

ALL OTHER TABLE SHAPES NESTING DIMENSIONS:

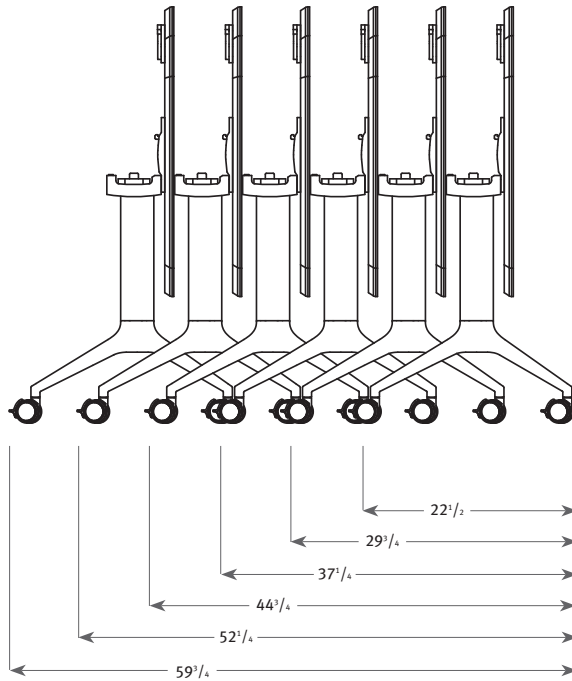
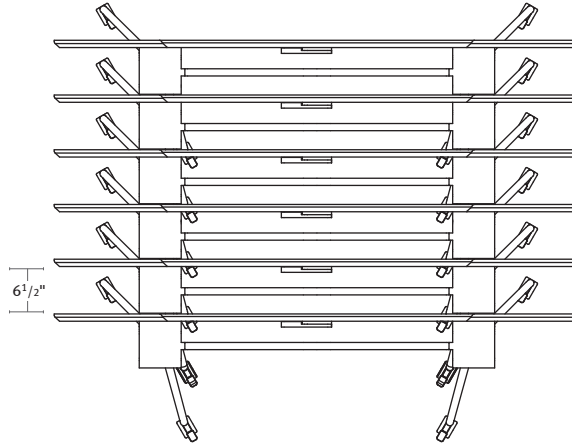
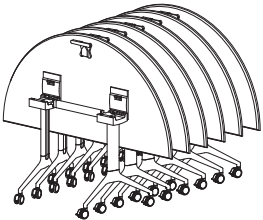
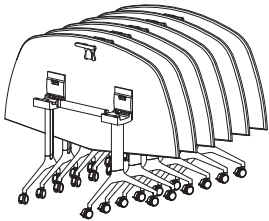
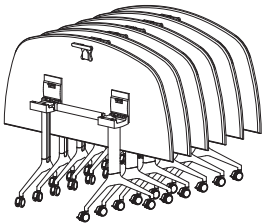
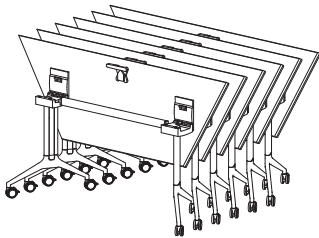
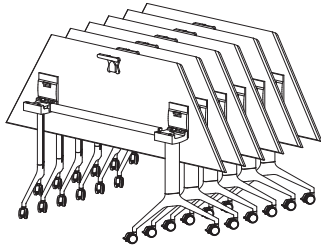

FLIRT® MULTI-PURPOSE MEETING TABLES // DESIGNED BY 5D STUDIO

CONFIGURATION EXAMPLES:

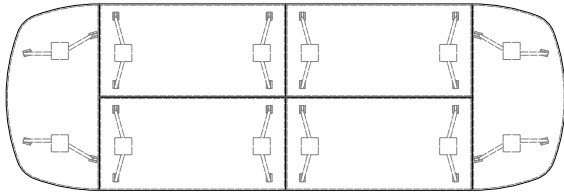

OVERALL DIMENSIONS:
180" x 60"

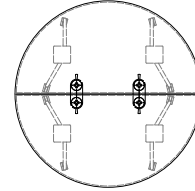

OVERALL DIMENSIONS:
60" x 60"

Qty	Model #	Description	List
4	FX1-306027-BV-EM	Rectangle Fixed Top, Bevel Edge and Edge Mount Base (\$3,605 ea.)	\$14,420
2	FX5-306027-BV	Radiused End Fixed Top, Bevel Edge and Inset Mount Base (\$3,413 ea.)	\$6,826
6			\$21,246

Qty	Model #	Description	List
2	FP4-306029-ES	Half Round Flip-Top Eased Edge (\$4,514 ea.)	\$9,028
1	GC05	Ganging Connector	\$121
			\$9,149

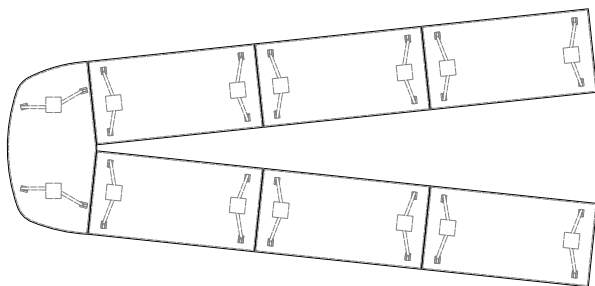

OVERALL DIMENSIONS:
211" x 99"

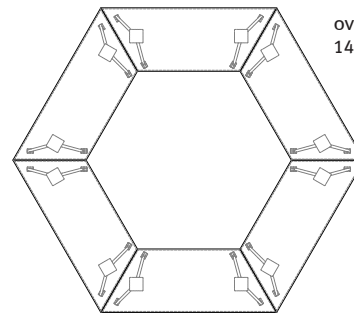

OVERALL DIMENSIONS:
144" x 125"

Qty	Model #	Description	List
6	FP1-306029-WF1-EM	Rectangle Flip-Up Top, Waterfall Edge and Edge Mount Base (\$4,618 ea.)	\$27,708
2	FP6-326229-BV	Video Conference End, Bevel Edge (\$4,647 ea.)	\$9,294
8			\$37,002

Qty	Model #	Description	List
6	FP2-307229-ES-EM	Trapezoid Flip-Top, Long Side, Eased Edge and Edge Mount Base (\$4,798)	\$28,788

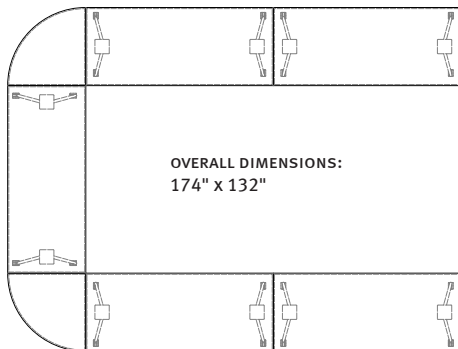





OVERALL DIMENSIONS:
174" x 132"

Qty	Model #	Description	List
5	FX1-307229-ES-EM	Rectangle Fixed Top, Eased Edge and Edge Mount Base (\$4,332 ea.)	\$21,660
2	FX7-2424-ES	Corner Table, Eased Edge (\$1,018 ea.)	\$2,036
8			\$23,696

FLIRT® MULTI-PURPOSE MEETING TABLES // DESIGNED BY 5D STUDIO

ORDERING REQUIREMENTS:

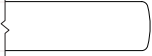
- » Model number
- » Wood species
- » Wood finish
- » Edge detail
- » Leg placement
- » Leg finish
- » Options, as applicable

		MODEL NUMBER	VENEER/LAMINATE EASED, BEVELED AND ONE-SIDED WATERFALL (-WF1)	VENEER OR LAMINATE TWO-SIDED WATERFALL (-WF2)	FENIX (-FE) EASED OR BEVELED EDGE	WEIGHT
FX1 SERIES						
Rectangle Fixed Top 27" High, Casters						
 Edge Mount Leg Placement	24" W x 48" L x 27" H	FX1-244827-(-)(-)	2498	N/A	2826	46
	24" W x 60" L x 27" H	FX1-246027-(-)(-)	3220	N/A	3630	53
	24" W x 66" L x 27" H	FX1-246627-(-)(-)	3300	N/A	3750	56
	24" W x 72" L x 27" H	FX1-247227-(-)(-)	3376	N/A	3867	59
	24" W x 78" L x 27" H	FX1-247827-(-)(-)	3924	N/A	4456	62
	24" W x 84" L x 27" H	FX1-248427-(-)(-)	3988	N/A	4561	66
 Inset Mount Leg Placement (not available on 48" length)	30" W x 48" L x 27" H	FX1-304827-(-)(-)	3090	N/A	3500	53
	30" W x 60" L x 27" H	FX1-306027-(-)(-)	3605	N/A	4117	61
	30" W x 66" L x 27" H	FX1-306627-(-)(-)	3906	N/A	4469	65
	30" W x 72" L x 27" H	FX1-307227-(-)(-)	4049	N/A	4663	69
	30" W x 78" L x 27" H	FX1-307827-(-)(-)	5137	N/A	5802	73
	30" W x 84" L x 27" H	FX1-308427-(-)(-)	5214	N/A	5930	77
Specify Leg Placement						
Edge Mount (-EM)						
Inset Mount (-IM)						
Specify Edge Style						
 Eased (-ES)	36" W x 48" L x 27" H	FX1-364827-(-)(-)	3232	3430	3723	61
	36" W x 60" L x 27" H	FX1-366027-(-)(-)	3939	4181	4553	71
	36" W x 66" L x 27" H	FX1-366627-(-)(-)	4056	4319	4731	76
	36" W x 72" L x 27" H	FX1-367227-(-)(-)	4199	4480	4936	81
	36" W x 78" L x 27" H	FX1-367827-(-)(-)	5289	5587	6087	85
	36" W x 84" L x 27" H	FX1-368427-(-)(-)	5368	5686	6227	90
 Beveled (-BV)	42" W x 60" L x 27" H	FX1-426027-(-)(-)	3869	4111	4585	80
	42" W x 66" L x 27" H	FX1-426627-(-)(-)	4179	4442	4967	86
	42" W x 72" L x 27" H	FX1-427227-(-)(-)	4321	4602	5180	91
	42" W x 78" L x 27" H	FX1-427827-(-)(-)	5413	5711	6344	97
	42" W x 84" L x 27" H	FX1-428427-(-)(-)	5494	5812	6497	103
	 Waterfall (-WF1/-WF2)					

OPTIONS

-GD00	Glides	n/c
-NS04	Non-Skid Glides	25
-PFM06	Premium Metal Leg Finish	278
-PFW05	Premium Wood Finish	75
-GR01	2" Diameter Grommet, Black	83
-GR02	2" Diameter Grommet, Chrome	111
-PX3-(-)	Power Matrix 3 (one power, one USB-A, one USB-C)	472
-PX4-(-)	Power Matrix 4 (dual power, one USB-A, one USB-C)	494
GC05 (order separately)	Flirt Ganging Connector (per table joint)	121

Please refer to pages 6-8 for daisy chain electrical requirements.

Note: For power matrix faceplate, please specify black (-B) or white (-W) finish.

FLIRT® MULTI-PURPOSE MEETING TABLES // DESIGNED BY 5D STUDIO

ORDERING REQUIREMENTS:

- » Model number
- » Wood species
- » Wood finish
- » Edge detail
- » Leg placement
- » Leg finish
- » Options, as applicable

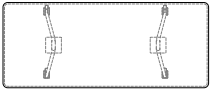
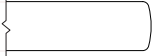
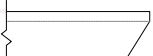
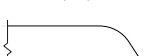
		MODEL NUMBER	VENEER/LAMINATE EASED, BEVELED AND ONE-SIDED WATERFALL (-WF1)	VENEER OR LAMINATE TWO-SIDED WATERFALL (-WF2)	FENIX (-FE) EASED OR BEVELED EDGE	WEIGHT
FX1 SERIES						
Rectangle Fixed Top 29" High, Casters						
 <p>Edge Mount Leg Placement</p>	24" W x 48" L x 29" H	FX1-244829-(-)(-)	2574	N/A	2902	48
	24" W x 60" L x 29" H	FX1-246029-(-)(-)	3296	N/A	3706	55
	24" W x 66" L x 29" H	FX1-246629-(-)(-)	3374	N/A	3824	58
	24" W x 72" L x 29" H	FX1-247229-(-)(-)	3451	N/A	3942	61
	24" W x 78" L x 29" H	FX1-247829-(-)(-)	4000	N/A	4532	64
	24" W x 84" L x 29" H	FX1-248429-(-)(-)	4062	N/A	4635	68
 <p>Inset Mount Leg Placement (not available on 48" length)</p>	30" W x 48" L x 29" H	FX1-304829-(-)(-)	3164	N/A	3574	55
	30" W x 60" L x 29" H	FX1-306029-(-)(-)	3678	N/A	4190	63
	30" W x 66" L x 29" H	FX1-306629-(-)(-)	4057	N/A	4620	67
	30" W x 72" L x 29" H	FX1-307229-(-)(-)	4332	N/A	4946	71
	30" W x 78" L x 29" H	FX1-307829-(-)(-)	5213	N/A	5878	75
	30" W x 84" L x 29" H	FX1-308429-(-)(-)	5288	N/A	6004	79
Specify Leg Placement						
Edge Mount (-EM)						
Inset Mount (-IM)						
 <p>Eased (-ES)</p>	36" W x 48" L x 29" H	FX1-364829-(-)(-)	3506	3546	3799	63
	36" W x 60" L x 29" H	FX1-366029-(-)(-)	4262	4312	4634	73
	36" W x 66" L x 29" H	FX1-366629-(-)(-)	4477	4539	4889	78
	36" W x 72" L x 29" H	FX1-367229-(-)(-)	4557	4634	5013	83
	36" W x 78" L x 29" H	FX1-367829-(-)(-)	5664	5706	6164	87
	36" W x 84" L x 29" H	FX1-368429-(-)(-)	5760	5818	6301	92
 <p>Beveled (-BV)</p>	42" W x 60" L x 29" H	FX1-426029-(-)(-)	4187	4241	4661	82
	42" W x 66" L x 29" H	FX1-426629-(-)(-)	4600	4656	5125	88
	42" W x 72" L x 29" H	FX1-427229-(-)(-)	4680	4751	5258	93
	42" W x 78" L x 29" H	FX1-427829-(-)(-)	5786	5822	6419	99
	42" W x 84" L x 29" H	FX1-428429-(-)(-)	5888	5940	6573	105
	 <p>Waterfall (-WF1/-WF2)</p>					

OPTIONS

-GD00	Glides	n/c
-NS04	Non-Skid Glides	25
-PFM06	Premium Metal Leg Finish	278
-PFW05	Premium Wood Finish	75
-GR01	2" Diameter Grommet, Black	83
-GR02	2" Diameter Grommet, Chrome	111
-PX3-(-)	Power Matrix 3 (one power, one USB-A, one USB-C)	472
-PX4-(-)	Power Matrix 4 (dual power, one USB-A, one USB-C)	494
GC05 (order separately)	Flirt Ganging Connector (per table joint)	121



Please refer to pages 6-8 for daisy chain electrical requirements.

Note: For power matrix faceplate, please specify black (-B) or white (-W) finish.

FLIRT® MULTI-PURPOSE MEETING TABLES // DESIGNED BY 5D STUDIO

ORDERING REQUIREMENTS:

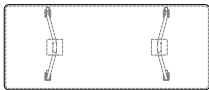
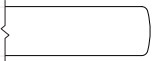
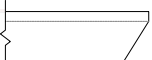
- » Model number
- » Wood species
- » Wood finish
- » Edge detail
- » Leg placement
- » Leg finish
- » Options, as applicable

		MODEL NUMBER	VENEER/LAMINATE EASED, BEVELED AND ONE-SIDED WATERFALL (-WF1)	VENEER OR LAMINATE TWO-SIDED WATERFALL (-WF2)	FENIX (-FE) EASED OR BEVELED EDGE	WEIGHT
FX1 SERIES						
Rectangle Fixed Top 42" High, Casters						
 <p>Edge Mount Leg Placement</p>	24" W x 60" L x 42" H	FX1-246042(-)-(-)	4186	N/A	4596	61
	24" W x 72" L x 42" H	FX1-247242(-)-(-)	4318	N/A	4809	67
	24" W x 84" L x 42" H	FX1-248442(-)-(-)	4554	N/A	5127	74
 <p>Inset Mount Leg Placement (not available on 48" length)</p>	30" W x 60" L x 42" H	FX1-306042(-)-(-)	4568	N/A	5080	69
	30" W x 72" L x 42" H	FX1-307242(-)-(-)	5091	N/A	5705	77
	30" W x 84" L x 42" H	FX1-308442(-)-(-)	5780	N/A	6496	85
Specify Leg Placement Edge Mount (-EM) Inset Mount (-IM)	36" W x 60" L x 42" H	FX1-366042(-)-(-)	5048	5290	5662	82
	36" W x 72" L x 42" H	FX1-367242(-)-(-)	5298	5579	6035	92
	36" W x 84" L x 42" H	FX1-368442(-)-(-)	5935	6253	6794	101
Specify Edge Style  <p>Eased (-ES)</p>  <p>Beveled (-BV)</p>  <p>Waterfall (-WF1/-WF2)</p>	42" W x 60" L x 42" H	FX1-426042(-)-(-)	4834	5076	5550	91
	42" W x 72" L x 42" H	FX1-427242(-)-(-)	5370	5651	6229	102
	42" W x 84" L x 42" H	FX1-428442(-)-(-)	6059	6377	7062	114

OPTIONS

-GD00	Glides	n/c
-NS04	Non-Skid Glides	25
-PFM06	Premium Metal Leg Finish	278
-PFW05	Premium Wood Finish	75
-GR01	2" Diameter Grommet, Black	83
-GR02	2" Diameter Grommet, Chrome	111
-PX3(-)	Power Matrix 3 (one power, one USB-A, one USB-C)	472
-PX4(-)	Power Matrix 4 (dual power, one USB-A, one USB-C)	494
GC05 (order separately)	Flirt Ganging Connector (per table joint)	121

Please refer to pages 6-8 for daisy chain electrical requirements.

Note: For power matrix faceplate, please specify black (-B) or white (-W) finish.

FLIRT® MULTI-PURPOSE MEETING TABLES // DESIGNED BY 5D STUDIO

ORDERING REQUIREMENTS:

- » Model number
- » Wood species
- » Wood finish
- » Edge detail
- » Leg placement
- » Leg finish
- » Options, as applicable

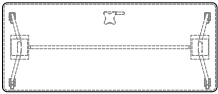
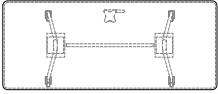
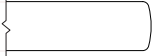
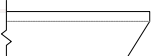
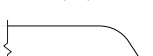
		MODEL NUMBER	VENEER/LAMINATE EASED, BEVELED AND ONE-SIDED WATERFALL (-WF1)	VENEER OR LAMINATE TWO-SIDED WATERFALL (-WF2)	FENIX (-FE) EASED OR BEVELED EDGE	WEIGHT
FP1 SERIES						
Rectangle Flip-Up Top, 27" High, Casters						
	24" W x 48" L x 27" H	FP1-244827-(-)(-)	3514	N/A	3842	49
	24" W x 60" L x 27" H	FP1-246027-(-)(-)	4161	N/A	4571	56
	24" W x 66" L x 27" H	FP1-246627-(-)(-)	4281	N/A	4731	59
	24" W x 72" L x 27" H	FP1-247227-(-)(-)	4358	N/A	4849	62
	24" W x 78" L x 27" H	FP1-247827-(-)(-)	4990	N/A	5522	65
	24" W x 84" L x 27" H	FP1-248427-(-)(-)	5053	N/A	5626	69
	30" W x 48" L x 27" H	FP1-304827-(-)(-)	4156	N/A	4566	56
	30" W x 60" L x 27" H	FP1-306027-(-)(-)	4542	N/A	5054	64
Specify Leg Placement Edge Mount (-EM) Inset Mount (-IM) <small>(not available on 48" length)</small>	30" W x 66" L x 27" H	FP1-306627-(-)(-)	4902	N/A	5465	68
	30" W x 72" L x 27" H	FP1-307227-(-)(-)	5031	N/A	5645	72
	30" W x 78" L x 27" H	FP1-307827-(-)(-)	6203	N/A	6868	76
	30" W x 84" L x 27" H	FP1-308427-(-)(-)	6278	N/A	6994	80
	36" W x 48" L x 27" H	FP1-364827-(-)(-)	4467	4665	4958	64
	36" W x 60" L x 27" H	FP1-366027-(-)(-)	4878	5120	5492	74
Specify Edge Style	36" W x 66" L x 27" H	FP1-366627-(-)(-)	5052	5315	5727	79
	36" W x 72" L x 27" H	FP1-367227-(-)(-)	5180	5461	5917	84
	36" W x 78" L x 27" H	FP1-367827-(-)(-)	6354	6652	7152	88
	36" W x 84" L x 27" H	FP1-368427-(-)(-)	6432	6750	7291	93
						
						
						

OPTIONS

-GD00	Glides	n/c
-NS04	Non-Skid Glides	25
-PFM06	Premium Metal Leg Finish	278
-PFW05	Premium Wood Finish	75
-GR01	2" Diameter Grommet, Black	83
-GR02	2" Diameter Grommet, Chrome	111
-PX3-(-)	Power Matrix 3 (one power, one USB-A, one USB-C)	472
-PX4-(-)	Power Matrix 4 (dual power, one USB-A, one USB-C)	494
GC05 (order separately)	Flirt Ganging Connector (per table joint)	121



Please refer to pages 6-8 for daisy chain electrical requirements.

Note: For power matrix faceplate, please specify black (-B) or white (-W) finish.

FLIRT® MULTI-PURPOSE MEETING TABLES // DESIGNED BY 5D STUDIO

ORDERING REQUIREMENTS:

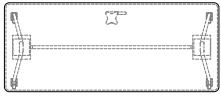
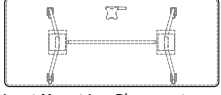
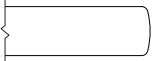
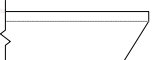
- » Model number
- » Wood species
- » Wood finish
- » Edge detail
- » Leg placement
- » Leg finish
- » Options, as applicable

		MODEL NUMBER	VENEER/LAMINATE EASED, BEVELED AND ONE-SIDED WATERFALL (-WF1)	VENEER OR LAMINATE TWO-SIDED WATERFALL (-WF2)	FENIX (-FE) EASED OR BEVELED EDGE	WEIGHT	
FP1 SERIES							
Rectangle Flip-Up Top, 29" High, Casters							
 <p>Edge Mount Leg Placement</p>	24" W x 48" L x 29" H	FP1-244829-(-)(-)	3589	N/A	3917	51	
	24" W x 60" L x 29" H	FP1-246029-(-)(-)	4234	N/A	4644	58	
	24" W x 66" L x 29" H	FP1-246629-(-)(-)	4354	N/A	4804	61	
	24" W x 72" L x 29" H	FP1-247229-(-)(-)	4835	N/A	5326	64	
	24" W x 78" L x 29" H	FP1-247829-(-)(-)	5523	N/A	6055	67	
	24" W x 84" L x 29" H	FP1-248429-(-)(-)	5593	N/A	6166	71	
 <p>Inset Mount Leg Placement (not available on 48" length)</p>	30" W x 48" L x 29" H	FP1-304829-(-)(-)	4231	N/A	4641	58	
	30" W x 60" L x 29" H	FP1-306029-(-)(-)	4618	N/A	5130	66	
	30" W x 66" L x 29" H	FP1-306629-(-)(-)	4977	N/A	5540	70	
	30" W x 72" L x 29" H	FP1-307229-(-)(-)	5106	N/A	5720	74	
	30" W x 78" L x 29" H	FP1-307829-(-)(-)	6276	N/A	6941	79	
	30" W x 84" L x 29" H	FP1-308429-(-)(-)	6353	N/A	7069	82	
Specify Leg Placement							
Edge Mount (-EM)							
Inset Mount (-IM)		36" W x 48" L x 29" H	FP1-364829-(-)(-)	4375	4573	4866	66
		36" W x 60" L x 29" H	FP1-366029-(-)(-)	4956	5198	5570	76
		36" W x 66" L x 29" H	FP1-366629-(-)(-)	5130	5393	5805	81
		36" W x 72" L x 29" H	FP1-367229-(-)(-)	5257	5538	5994	86
		36" W x 78" L x 29" H	FP1-367829-(-)(-)	6429	6727	7227	90
		36" W x 84" L x 29" H	FP1-368429-(-)(-)	6508	6826	7367	95
Specify Edge Style							
 <p>Eased (-ES)</p>							
 <p>Beveled (-BV)</p>							
 <p>Waterfall (-WF1/-WF2)</p>							

OPTIONS

-GD00	Glides	n/c
-NS04	Non-Skid Glides	25
-PFM06	Premium Metal Leg Finish	278
-PFW05	Premium Wood Finish	75
-GR01	2" Diameter Grommet, Black	83
-GR02	2" Diameter Grommet, Chrome	111
-PX3(-)	Power Matrix 3 (one power, one USB-A, one USB-C)	472
-PX4(-)	Power Matrix 4 (dual power, one USB-A, one USB-C)	494
GC05 (order separately)	Flirt Ganging Connector (per table joint)	121

Please refer to pages 6-8 for daisy chain electrical requirements.



Note: For power matrix faceplate, please specify black (-B) or white (-W) finish.

FLIRT® MULTI-PURPOSE MEETING TABLES // DESIGNED BY 5D STUDIO

ORDERING REQUIREMENTS:

- » Model number
- » Wood species
- » Wood finish
- » Edge detail
- » Leg finish
- » Options, as applicable

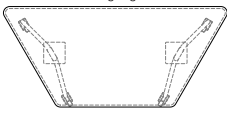
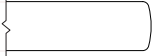
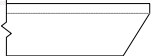
Note: Waterfall edge offered in veneer or laminate only and is presented on leading edge (long side) with remaining three sides featuring beveled edge detail.

		MODEL NUMBER	VENEER OR LAMINATE	FENIX (-FE)	WEIGHT	
FX2 SERIES  Leading Edge Edge Mount Leg Placement	Trapezoid Fixed Top, Long Side 27" High, Casters Edge Mount Leg Placement Only	21" W x 48" L x 27" H 21" W x 60" L x 27" H 26" W x 60" L x 27" H 26" W x 72" L x 27" H	FX2-244827(-)-EM FX2-246027(-)-EM FX2-306027(-)-EM FX2-307227(-)-EM	2417 3128 3166 3786	2704 3486 3610 4318	38 44 48 54
	Trapezoid Fixed Top, Long Side 29" High, Casters Edge Mount Leg Placement Only	21" W x 48" L x 29" H 21" W x 60" L x 29" H 26" W x 60" L x 29" H 26" W x 72" L x 29" H	FX2-244829(-)-EM FX2-246029(-)-EM FX2-306029(-)-EM FX2-307229(-)-EM	2494 3204 3240 3861	2781 3562 3684 4393	40 46 50 56
Specify Edge Style  Eased (-ES)  Beveled (-BV)  Waterfall (-WF1) - veneer or laminate finish only						

OPTIONS

-GD00	Glides	n/c
-NS04	Non-Skid Glides	25
-PFM06	Premium Metal Leg Finish	278
-PFW05	Premium Wood Finish	75
-GR01	2" Diameter Grommet, Black	83
-GR02	2" Diameter Grommet, Chrome	111
-PX3(-)	Power Matrix 3 (one power, one USB-A, one USB-C)	472
-PX4(-)	Power Matrix 4 (dual power, one USB-A, one USB-C)	494
GC05 (order separately)	Flirt Ganging Connector (per table joint)	121

Please refer to pages 6-8 for daisy chain electrical requirements.



Note: For power matrix faceplate, please specify black (-B) or white (-W) finish.

FLIRT® MULTI-PURPOSE MEETING TABLES // DESIGNED BY 5D STUDIO

ORDERING REQUIREMENTS:

- » Model number
- » Wood species
- » Wood finish
- » Edge detail
- » Leg finish
- » Options, as applicable

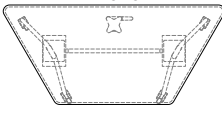
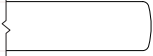
Note: Waterfall edge offered in veneer or laminate only and is presented on leading edge (long side) with remaining three sides featuring beveled edge detail.

		MODEL NUMBER	VENEER OR LAMINATE	FENIX (-FE)	WEIGHT	
FP2 SERIES  Edge Mount Leg Placement	Trapezoid Flip-Up Top, Long Side 27\" High, Casters Edge Mount Leg Placement Only	21\" W x 48\" L x 27\" H 21\" W x 60\" L x 27\" H 26\" W x 60\" L x 27\" H 26\" W x 72\" L x 27\" H	FP2-244827-()-EM FP2-246027-()-EM FP2-306027-()-EM FP2-307227-()-EM	3434 4067 4106 4724	3721 4425 4550 5256	40 46 50 56
	Trapezoid Flip-Up Top, Long Side 29\" High, Casters Edge Mount Leg Placement Only	21\" W x 48\" L x 29\" H 21\" W x 60\" L x 29\" H 26\" W x 60\" L x 29\" H 26\" W x 72\" L x 29\" H	FP2-244829-()-EM FP2-246029-()-EM FP2-306029-()-EM FP2-307229-()-EM	3511 4142 4179 4798	3798 4500 4623 5330	42 48 52 58
Specify Edge Style  Eased (-ES)  Beveled (-BV)  Waterfall (-WF1) - veneer or laminate finish only						

OPTIONS

-GD00	Glides	n/c
-NS04	Non-Skid Glides	25
-PFM06	Premium Metal Leg Finish	278
-PFW05	Premium Wood Finish	75
-GR01	2\" Diameter Grommet, Black	83
-GR02	2\" Diameter Grommet, Chrome	111
-PX3-()	Power Matrix 3 (one power, one USB-A, one USB-C)	472
-PX4-()	Power Matrix 4 (dual power, one USB-A, one USB-C)	494
GC05 (order separately)	Flirt Ganging Connector (per table joint)	121

Please refer to pages 6-8 for daisy chain electrical requirements.

Note: For power matrix faceplate, please specify black (-B) or white (-W) finish.

FLIRT® MULTI-PURPOSE MEETING TABLES // DESIGNED BY 5D STUDIO

ORDERING REQUIREMENTS:

- » Model number
- » Wood species
- » Wood finish
- » Edge detail
- » Leg finish
- » Options, as applicable

Note: Waterfall edge offered in veneer or laminate only and is presented on leading edge (long side) with remaining three sides featuring beveled edge detail.

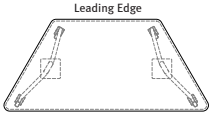
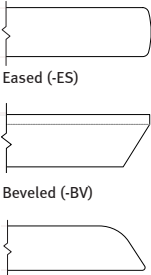
		MODEL NUMBER	VENEER OR LAMINATE	FENIX (-FE)	WEIGHT	
FX3 SERIES  Edge Mount Leg Placement	Trapezoid Fixed Top, Short Side 27" High, Casters Edge Mount Leg Placement Only	21" W x 48" L x 27" H 21" W x 60" L x 27" H 26" W x 60" L x 27" H 26" W x 72" L x 27" H	FX3-244827-()-EM FX3-246027-()-EM FX3-306027-()-EM FX3-307227-()-EM	2368 3128 3166 3786	2655 3486 3610 4318	38 44 48 54
	Trapezoid Fixed Top, Short Side 29" High, Casters Edge Mount Leg Placement Only	21" W x 48" L x 29" H 21" W x 60" L x 29" H 26" W x 60" L x 29" H 26" W x 72" L x 29" H	FX3-244829-()-EM FX3-246029-()-EM FX3-306029-()-EM FX3-307229-()-EM	2445 3204 3240 3861	2732 3562 3684 4393	40 46 50 56
Specify Edge Style  Eased (-ES) Beveled (-BV) Waterfall (-WF1) - veneer or laminate finish only						

OPTIONS

-GD00	Glides	n/c
-NS04	Non-Skid Glides	25
-PFM06	Premium Metal Leg Finish	278
-PFW05	Premium Wood Finish	75
-GR01	2" Diameter Grommet, Black	83
-GR02	2" Diameter Grommet, Chrome	111
-PX3-()	Power Matrix 3 (one power, one USB-A, one USB-C)	472
-PX4-()	Power Matrix 4 (dual power, one USB-A, one USB-C)	494
GC05 (order separately)	Flirt Ganging Connector (per table joint)	121

Please refer to pages 6-8 for daisy chain electrical requirements.



Note: For power matrix faceplate, please specify black (-B) or white (-W) finish.

FLIRT® MULTI-PURPOSE MEETING TABLES // DESIGNED BY 5D STUDIO

ORDERING REQUIREMENTS:

- » Model number
- » Wood species
- » Wood finish
- » Edge detail
- » Leg finish
- » Options, as applicable

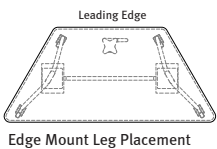
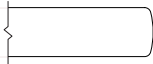
Note: Waterfall edge offered in veneer or laminate only and is presented on leading edge (long side) with remaining three sides featuring beveled edge detail.

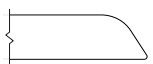
		MODEL NUMBER	VENEER OR LAMINATE	FENIX (-FE)	WEIGHT	
FP3 SERIES 	Trapezoid Flip-Up Top, Short Side 27" High, Casters Edge Mount Leg Placement Only	21" W x 48" L x 27" H 21" W x 60" L x 27" H 26" W x 60" L x 27" H 26" W x 72" L x 27" H	FP3-244827-()-EM FP3-246027-()-EM FP3-306027-()-EM FP3-307227-()-EM	3434 4067 4106 4724	3721 4425 4550 5256	40 46 50 56
	Trapezoid Flip-Up Top, Short Side 29" High, Casters Edge Mount Leg Placement Only	21" W x 48" L x 29" H 21" W x 60" L x 29" H 26" W x 60" L x 29" H 26" W x 72" L x 29" H	FP3-244829-()-EM FP3-246029-()-EM FP3-306029-()-EM FP3-307229-()-EM	3511 4142 4179 4798	3798 4500 4623 5330	42 48 52 58
Specify Edge Style  Eased (-ES)  Beveled (-BV)  Waterfall (-WF1) - veneer or laminate finish only						

OPTIONS

-GD00	Glides	n/c
-NS04	Non-Skid Glides	25
-PFM06	Premium Metal Leg Finish	278
-PFW05	Premium Wood Finish	75
-GR01	2" Diameter Grommet, Black	83
-GR02	2" Diameter Grommet, Chrome	111
-PX3-()	Power Matrix 3 (one power, one USB-A, one USB-C)	472
-PX4-()	Power Matrix 4 (dual power, one USB-A, one USB-C)	494
GC05 (order separately)	Flirt Ganging Connector (per table joint)	121



Please refer to pages 6-8 for daisy chain electrical requirements.

Note: For power matrix faceplate, please specify black (-B) or white (-W) finish.

FLIRT® MULTI-PURPOSE MEETING TABLES // DESIGNED BY 5D STUDIO

ORDERING REQUIREMENTS:

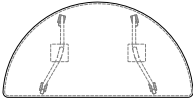
- » Model number
- » Wood species
- » Wood finish
- » Edge detail
- » Leg finish
- » Options, as applicable

	MODEL NUMBER	VENEER OR LAMINATE	FENIX (-FE)	WEIGHT		
FX4 SERIES						
 <p>Inset Mount Leg Placement</p>	Half-Round Fixed Top 27" High, Casters Inset Leg Placement Only					
	Eased Edge Detail 24" W x 48" L x 27" H 30" W x 60" L x 27" H 36" W x 72" L x 27" H		FX4-244827-ES-IM FX4-306027-ES-IM FX4-367227-ES-IM	2833 3520 3935	3161 4032 4672	41 51 68
	Beveled Edge Detail 24" W x 48" L x 27" H 30" W x 60" L x 27" H 36" W x 72" L x 27" H		FX4-244827-BV-IM FX4-306027-BV-IM FX4-367227-BV-IM	2833 3520 3935	3161 4032 4672	41 52 68
	Half-Round Fixed Top 29" High, Casters Inset Leg Placement Only					
	Eased Edge Detail 24" W x 48" L x 29" H 30" W x 60" L x 29" H 36" W x 72" L x 29" H		FX4-244829-ES-IM FX4-306029-ES-IM FX4-367229-ES-IM	2908 3599 4008	3236 4111 4745	43 54 70
	Beveled Edge Detail 24" W x 48" L x 29" H 30" W x 60" L x 29" H 36" W x 72" L x 29" H		FX4-244829-BV-IM FX4-306029-BV-IM FX4-367229-BV-IM	2908 3599 4008	3236 4111 4745	43 54 70
Specify Edge Style						
 <p>Eased (-ES)</p>						
 <p>Beveled (-BV)</p>						

OPTIONS

-GD00	Glides	n/c
-NS04	Non-Skid Glides	25
-PFM06	Premium Metal Leg Finish	278
-PFW05	Premium Wood Finish	75
-GR01	2" Diameter Grommet, Black	83
-GR02	2" Diameter Grommet, Chrome	111
-PX3(-)	Power Matrix 3 (one power, one USB-A, one USB-C)	472
-PX4(-)	Power Matrix 4 (dual power, one USB-A, one USB-C)	494
GC05 (order separately)	Flirt Ganging Connector (per table joint)	121



Please refer to pages 6-8 for daisy chain electrical requirements.

Note: For power matrix faceplate, please specify black (-B) or white (-W) finish.

FLIRT® MULTI-PURPOSE MEETING TABLES // DESIGNED BY 5D STUDIO

ORDERING REQUIREMENTS:

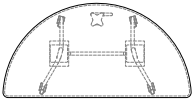
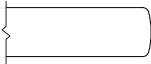
- » Model number
- » Wood species
- » Wood finish
- » Edge detail
- » Leg finish
- » Options, as applicable

		MODEL NUMBER	VENEER OR LAMINATE	FENIX (-FE)	WEIGHT
<p>FP4 SERIES</p>  <p>Inset Mount Leg Placement</p> <p>Specify Edge Style</p>  <p>Eased (-ES)</p>  <p>Beveled (-BV)</p>	<p>Half-Round Flip-Up Top 27" High, Casters Inset Leg Placement Only</p> <p>Eased Edge Detail 24" W x 48" L x 27" H 30" W x 60" L x 27" H 36" W x 72" L x 27" H</p> <p>Beveled Edge Detail 24" W x 48" L x 27" H 30" W x 60" L x 27" H 36" W x 72" L x 27" H</p>	<p>FP4-244827-ES-IM FP4-306027-ES-IM FP4-367227-ES-IM</p> <p>FP4-244827-BV-IM FP4-306027-BV-IM FP4-367227-BV-IM</p>	<p>3899 4440 4872</p> <p>3899 4440 4872</p>	<p>4227 4952 5609</p> <p>4227 4952 5609</p>	<p>44 55 71</p> <p>44 55 71</p>
	<p>Half-Round Flip-Up Top 29" High, Casters Inset Leg Placement Only</p> <p>Eased Edge Detail 24" W x 48" L x 29" H 30" W x 60" L x 29" H 36" W x 72" L x 29" H</p> <p>Beveled Edge Detail 24" W x 48" L x 29" H 30" W x 60" L x 29" H 36" W x 72" L x 29" H</p>	<p>FP4-244829-ES-IM FP4-306029-ES-IM FP4-367229-ES-IM</p> <p>FP4-244829-BV-IM FP4-306029-BV-IM FP4-367229-BV-IM</p>	<p>3974 4514 4948</p> <p>3974 4514 4948</p>	<p>4302 5026 5685</p> <p>4302 5026 5685</p>	<p>46 57 73</p> <p>46 57 73</p>

OPTIONS

-GD00	Glides	n/c
-NS04	Non-Skid Glides	25
-PFM06	Premium Metal Leg Finish	278
-PFW05	Premium Wood Finish	75
-GR01	2" Diameter Grommet, Black	83
-GR02	2" Diameter Grommet, Chrome	111
-PX3(-)	Power Matrix 3 (one power, one USB-A, one USB-C)	472
-PX4(-)	Power Matrix 4 (dual power, one USB-A, one USB-C)	494
GC05 (order separately)	Flirt Ganging Connector (per table joint)	121



Please refer to pages 6-8 for daisy chain electrical requirements.

Note: For power matrix faceplate, please specify black (-B) or white (-W) finish.

FLIRT® MULTI-PURPOSE MEETING TABLES // DESIGNED BY 5D STUDIO

ORDERING REQUIREMENTS:

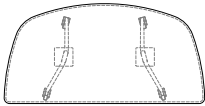
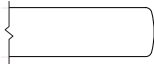
- » Model number
- » Wood species
- » Wood finish
- » Edge detail
- » Leg finish
- » Options, as applicable

		MODEL NUMBER	VENEER OR LAMINATE	FENIX (-FE)	WEIGHT
<p>FX5 SERIES</p>  <p>Inset Mount Leg Placement</p> <p>Specify Edge Style</p>  <p>Eased (-ES)</p>  <p>Beveled (-BV)</p>	<p>Radiused End Connecting Table Fixed Top, 27" High, Casters Inset Leg Placement Only</p> <p>Eased Edge Detail 24" W x 48" L x 27" H 30" W x 60" L x 27" H 36" W x 72" L x 27" H</p> <p>Beveled Edge Detail 24" W x 48" L x 27" H 30" W x 60" L x 27" H 36" W x 72" L x 27" H</p>	<p>FX5-244827-ES-IM FX5-306027-ES-IM FX5-367227-ES-IM</p> <p>FX5-244827-BV-IM FX5-306027-BV-IM FX5-367227-BV-IM</p>	<p>2840 3413 4004</p> <p>2840 3413 4004</p>	<p>3168 3925 4741</p> <p>3168 3925 4741</p>	<p>46 59 75</p> <p>46 59 75</p>
	<p>Radiused End Connecting Table Fixed Top, 29" High, Casters Inset Leg Placement Only</p> <p>Eased Edge Detail 24" W x 48" L x 29" H 30" W x 60" L x 29" H 36" W x 72" L x 29" H</p> <p>Beveled Edge Detail 24" W x 48" L x 29" H 30" W x 60" L x 29" H 36" W x 72" L x 29" H</p>	<p>FX5-244829-ES-IM FX5-306029-ES-IM FX5-367229-ES-IM</p> <p>FX5-244829-BV-IM FX5-306029-BV-IM FX5-367229-BV-IM</p>	<p>2914 3488 4079</p> <p>2914 3488 4079</p>	<p>3242 4000 4816</p> <p>3242 4000 4816</p>	<p>48 61 77</p> <p>48 61 77</p>

OPTIONS

-GD00	Glides	n/c
-NS04	Non-Skid Glides	25
-PFM06	Premium Metal Leg Finish	278
-PFW05	Premium Wood Finish	75
-GR01	2" Diameter Grommet, Black	83
-GR02	2" Diameter Grommet, Chrome	111
-PX3(-)	Power Matrix 3 (one power, one USB-A, one USB-C)	472
-PX4(-)	Power Matrix 4 (dual power, one USB-A, one USB-C)	494
GC05 (order separately)	Flirt Ganging Connector (per table joint)	121



Please refer to pages 6-8 for daisy chain electrical requirements.

Note: For power matrix faceplate, please specify black (-B) or white (-W) finish.

FLIRT® MULTI-PURPOSE MEETING TABLES // DESIGNED BY 5D STUDIO

ORDERING REQUIREMENTS:

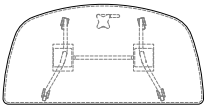
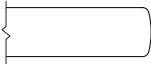
- » Model number
- » Wood species
- » Wood finish
- » Edge detail
- » Leg finish
- » Options, as applicable

	MODEL NUMBER	VENEER OR LAMINATE	FENIX (-FE)	WEIGHT	
<p>FP5 SERIES</p>  <p>Inset Mount Leg Placement</p> <p>Specify Edge Style</p>  <p>Eased (-ES)</p>  <p>Beveled (-BV)</p>	<p>Radiused End Connecting Table Flip-up Top, 27" High, Casters Inset Leg Placement Only</p> <p>Eased Edge Detail 24" W x 48" L x 27" H 30" W x 60" L x 27" H 36" W x 72" L x 27" H</p> <p>Beveled Edge Detail 24" W x 48" L x 27" H 30" W x 60" L x 27" H 36" W x 72" L x 27" H</p>	<p>FP5-244827-ES-IM FP5-306027-ES-IM FP5-367227-ES-IM</p> <p>FP5-244827-BV-IM FP5-306027-BV-IM FP5-367227-BV-IM</p>	<p>3905 4378 4944</p> <p>3905 4378 4944</p>	<p>4233 4890 5681</p> <p>4233 4890 5681</p>	<p>49 62 78</p> <p>49 62 78</p>
	<p>Radiused End Connecting Table Flip-Up Top, 29" High, Casters Inset Leg Placement Only</p> <p>Eased Edge Detail 24" W x 48" L x 29" H 30" W x 60" L x 29" H 36" W x 72" L x 29" H</p> <p>Beveled Edge Detail 24" W x 48" L x 29" H 30" W x 60" L x 29" H 36" W x 72" L x 29" H</p>	<p>FP5-244829-ES-IM FP5-306029-ES-IM FP5-367229-ES-IM</p> <p>FP5-244829-BV-IM FP5-306029-BV-IM FP5-367229-BV-IM</p>	<p>3978 4452 5016</p> <p>3978 4452 5016</p>	<p>4306 4964 5753</p> <p>4306 4964 5753</p>	<p>51 64 80</p> <p>51 64 80</p>

OPTIONS

-GD00	Glides	n/c
-NS04	Non-Skid Glides	25
-PFM06	Premium Metal Leg Finish	278
-PFW05	Premium Wood Finish	75
-GR01	2" Diameter Grommet, Black	83
-GR02	2" Diameter Grommet, Chrome	111
-PX3-()	Power Matrix 3 (one power, one USB-A, one USB-C)	472
-PX4-()	Power Matrix 4 (dual power, one USB-A, one USB-C)	494
GC05 (order separately)	Flirt Ganging Connector (per table joint)	121



Please refer to pages 6-8 for daisy chain electrical requirements.

Note: For power matrix faceplate, please specify black (-B) or white (-W) finish.

FLIRT® MULTI-PURPOSE MEETING TABLES // DESIGNED BY 5D STUDIO

ORDERING REQUIREMENTS:

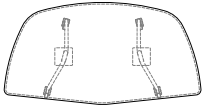
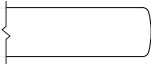
- » Model number
- » Wood species
- » Wood finish
- » Edge detail
- » Leg finish
- » Options, as applicable

	MODEL NUMBER	VENEER OR LAMINATE	FENIX (-FE)	WEIGHT	
FX6 SERIES					
 <p>Inset Mount Leg Placement</p>	Video Conference End Connecting Table Fixed Top, 27" High, Casters Inset Leg Placement Only				
	Eased Edge Detail				
	26" W x 50" L x 27" H	FX6-265027-ES-IM	2850	3220	45
	32" W x 62" L x 27" H	FX6-326227-ES-IM	3559	4123	57
	38" W x 74" L x 27" H	FX6-387427-ES-IM	4018	4817	71
	Beveled Edge Detail				
26" W x 50" L x 27" H	FX6-265027-BV-IM	2850	3220	45	
32" W x 62" L x 27" H	FX6-326227-BV-IM	3559	4123	57	
38" W x 74" L x 27" H	FX6-387427-BV-IM	4018	4817	71	
<p>Specify Edge Style</p>  <p>Eased (-ES)</p>  <p>Beveled (-BV)</p>	Video Conference End Connecting Table Fixed Top, 29" High, Casters Inset Leg Placement Only				
	Eased Edge Detail				
	26" W x 50" L x 29" H	FX6-265029-ES-IM	2927	3297	47
	32" W x 62" L x 29" H	FX6-326229-ES-IM	3639	4203	59
	38" W x 74" L x 29" H	FX6-387429-ES-IM	4089	4888	73
	Beveled Edge Detail				
26" W x 50" L x 29" H	FX6-265029-BV-IM	2927	3297	47	
32" W x 62" L x 29" H	FX6-326229-BV-IM	3639	4203	59	
38" W x 74" L x 29" H	FX6-387429-BV-IM	4089	4888	73	

OPTIONS

-GD00	Glides	n/c
-NS04	Non-Skid Glides	25
-PFM06	Premium Metal Leg Finish	278
-PFW05	Premium Wood Finish	75
-GR01	2" Diameter Grommet, Black	83
-GR02	2" Diameter Grommet, Chrome	111
-PX3(-)	Power Matrix 3 (one power, one USB-A, one USB-C)	472
-PX4(-)	Power Matrix 4 (dual power, one USB-A, one USB-C)	494
GC05 (order separately)	Flirt Ganging Connector (per table joint)	121

Please refer to pages 6-8 for daisy chain electrical requirements.

Note: For power matrix faceplate, please specify black (-B) or white (-W) finish.

FLIRT® MULTI-PURPOSE MEETING TABLES // DESIGNED BY 5D STUDIO

ORDERING REQUIREMENTS:

- » Model number
- » Wood species
- » Wood finish
- » Edge detail
- » Leg finish
- » Options, as applicable

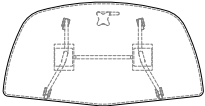
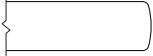
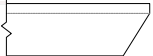
		MODEL NUMBER	VENEER OR LAMINATE	FENIX (-FE)	WEIGHT
<p>FP6 SERIES</p>  <p>Inset Mount Leg Placement</p> <p>Specify Edge Style</p>  <p>Eased (-ES)</p>  <p>Beveled (-BV)</p>	<p>Video Conference End Connecting Table Flip-Up Top, 27" High, Casters Inset Leg Placement Only</p> <p>Eased Edge Detail 26" W x 50" L x 27" H 32" W x 62" L x 27" H 38" W x 74" L x 27" H</p> <p>Beveled Edge Detail 26" W x 50" L x 27" H 32" W x 62" L x 27" H 38" W x 74" L x 27" H</p>	<p>FP6-265027-ES-IM FP6-326227-ES-IM FP6-387427-ES-IM</p> <p>FP6-265027-BV-IM FP6-326227-BV-IM FP6-387427-BV-IM</p>	<p>3917 4568 5054</p> <p>3917 4568 5054</p>	<p>4287 5132 5853</p> <p>4287 5132 5853</p>	<p>48 60 74</p> <p>48 60 74</p>
	<p>Video Conference End Connecting Table Flip-Up Top, 29" High, Casters Inset Leg Placement Only</p> <p>Eased Edge Detail 26" W x 50" L x 29" H 32" W x 62" L x 29" H 38" W x 74" L x 29" H</p> <p>Beveled Edge Detail 26" W x 50" L x 29" H 32" W x 62" L x 29" H 38" W x 74" L x 29" H</p>	<p>FP6-265029-ES-IM FP6-326229-ES-IM FP6-387429-ES-IM</p> <p>FP6-265029-BV-IM FP6-326229-BV-IM FP6-387429-BV-IM</p>	<p>3992 4647 5132</p> <p>3992 4647 5132</p>	<p>4362 5211 5931</p> <p>4362 5211 5931</p>	<p>50 62 76</p> <p>50 62 76</p>

OPTIONS

-GD00	Glides	n/c
-NS04	Non-Skid Glides	25
-PFM06	Premium Metal Leg Finish	278
-PFW05	Premium Wood Finish	75
-GR01	2" Diameter Grommet, Black	83
-GR02	2" Diameter Grommet, Chrome	111
-PX3-()	Power Matrix 3 (one power, one USB-A, one USB-C)	472
-PX4-()	Power Matrix 4 (dual power, one USB-A, one USB-C)	494
GC05 (order separately)	Flirt Ganging Connector (per table joint)	121

Please refer to pages 6-8 for daisy chain electrical requirements.

Note: For power matrix faceplate, please specify black (-B) or white (-W) finish.

FLIRT® MULTI-PURPOSE MEETING TABLES // DESIGNED BY 5D STUDIO

ORDERING REQUIREMENTS:

- » Model number
- » Wood species
- » Wood finish
- » Edge detail
- » Options, as applicable

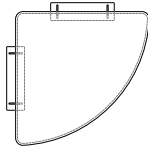
		MODEL NUMBER	VENEER OR LAMINATE	FENIX (-FE)	WEIGHT
FX7 SERIES	Corner Connecting Table, No Legs				
	Eased Edge Detail				
	24" W x 24" L	FX7-2424-ES	1018	1182	11
	30" W x 30" L	FX7-3030-ES	1267	1523	16
	36" W x 36" L	FX7-3636-ES	1544	1913	25
	Beveled Edge Detail				
	24" W x 24" L	FX7-2424-BV	1018	1182	11
30" W x 30" L	FX7-3030-BV	1267	1523	16	
36" W x 36" L	FX7-3636-BV	1544	1913	25	

Specify Edge Style

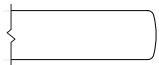

Eased (-ES)

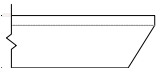

Beveled (-BV)

OPTIONS

-PFW05	Premium Wood Finish	75
-GR01	2" Diameter Grommet, Black	83
-GR02	2" Diameter Grommet, Chrome	111

FLIRT® MULTI-PURPOSE MEETING TABLES // DESIGNED BY 5D STUDIO

MODESTY PANEL NOTES:

- » 8" high x 1/2" thick panels available on fixed or flip-up rectangle and trapezoid tables.
- » Power units not available on tables specified with modesty panels and inset mount bases.
- » Bottom of the panel from the floor dimension is as follows:
 - 27" high tables - 16 1/4"
 - 29" high tables - 19 1/4"
 - 42" high tables - 31 1/2"

ORDERING REQUIREMENTS:

- » Model number
- » Wood species
- » Wood finish

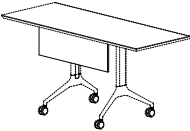
		MODEL NUMBER	PANEL LENGTH	VENEER OR LAMINATE	FENIX (-FE)	WEIGHT	
MODESTY PANELS 	Rectangle Top Edge Mount Table Bases Table Length 48" 60" 66" 72" 78" 84"	MP42 MP54 MP60 MP66 MP72 MP78	42" 54" 60" 66" 72" 78"	729 890 972 1054 1136 1213	825 1013 1109 1204 1300 1391	5 6 7 8 9 10	
		Rectangle Top Inset Mount Table Bases Table Length 60" 66" 72" 78" 84"	MP30 MP36 MP42 MP48 MP54	30" 36" 42" 48" 54"	565 646 729 809 890	634 728 825 919 1013	3 5 6 7 8

OPTIONS

-PFW05	Premium Wood Finish	75
--------	---------------------	----

FLIRT® MULTI-PURPOSE MEETING TABLES // DESIGNED BY 5D STUDIO

MODESTY PANEL NOTES:

- » 8" high x 1/2" thick panels available on fixed or flip-up rectangle and trapezoid tables.
- » Power units not available on tables specified with modesty panels and inset mount bases.
- » Bottom of the panel from the floor dimension is as follows:
 - 27" high tables - 16 1/4"
 - 29" high tables - 19 1/4"
 - 42" high tables - 31 1/2"

ORDERING REQUIREMENTS:

- » Model number
- » Wood species
- » Wood finish

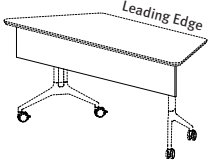
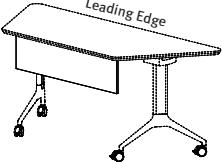
		MODEL NUMBER	PANEL LENGTH	VENEER OR LAMINATE	FENIX (-FE)	WEIGHT
<p>MODESTY PANELS</p>  <p>Trapezoid Top, Long Side (FP3/FX3 Tables)</p> <p>Leading Edge Length 24" 30" (21" or 26" w) 36"</p>		MP42	42"	729	825	5
		MP54	54"	890	1013	6
		MP66	66"	1054	1204	8
 <p>Trapezoid Top, Short Side (FP2/FX2 Tables)</p> <p>Leading Edge Length 48" 60" (21" w) 60" (26" w) 72"</p>		MP18	18"	403	444	3
		MP30	30"	565	634	3
		MP24	24"	485	540	4
		MP42	42"	729	825	6

OPTIONS

-PFW05

Premium Wood Finish

75

FLIRT® MULTI-PURPOSE EASELS // DESIGNED BY 5D STUDIO

M.A.T.E. (MOBILE ALL-PURPOSE TEAMING EASEL) GENERAL PRODUCT FEATURES:

- » Available in two widths with overall height of 71" and comes standard with side-mount valet table.
- » Material options include maple, walnut and white oak veneer, laminate, magnetic laminate, upholstered with tackable surface or whiteboard, in any combination.
- » All standard wood finishes, excluding MA0915 Ebony Maple, available on selected wood species.
- » Premium wood finish upcharge applies to the following wood finishes. Refer to options section for pricing.
 - Super Matte Sable Maple
 - Alabaster Oak
 - Super Matte Sable Oak
- » For custom wood finishes, please add one-time upcharge of \$472 List per color per order.
- » Laminate available in all standard laminates.
- » For custom laminates, add \$590 List per color per order. Pre-approval required, please contact client services.
- » Panels specified with veneer or standard wood grain and solid black laminate, panel edge finish will match, unless otherwise specified.
- » Panels specified with all other solid color laminates, magnetic laminate or whiteboard, panel edge finish will be natural exposed plywood with a clear coat finish.
- » Panels specified with veneer or standard wood grain or solid black laminate, together with white board and/or pull-out whiteboards, all edges will match the color of the selected veneer or laminate.
- » Vinyl, polyurethane and leather upholstery not available.
- » Due to standard textile widths, 63" wide easel with upholstery requires a vertical seam. For seamless option, please select a panel fabric.
- » Please refer to page 38 for two-tone upholstery examples (different fabrics for each side), yardage requirements and pricing.
- » **When specifying, the first option code reflects placement in relation to the right side of the valet table, as facing. Second option code identifies panel material on the opposing side, with the valet table on the left, as facing.**
- » Center section (portion between panels) is finished in white laminate as standard. Black laminate available, please specify.
- » Storage slot standard on all models excluding upholstered panels. If specified with one side upholstered and one side whiteboard, veneer or laminate, the storage slot will be present on the non-upholstered side only.
- » Die-cast aluminum legs available in standard and premium metal finishes and feature four locking casters.

SIDE-MOUNT VALET TABLE FEATURES:

- » 15" diameter valet table offered in maple, walnut and white oak veneer as well as laminate selections.
- » Table edge finish will follow panel edge finish as standard, unless otherwise specified.
- » For double-sided upholstered panels with veneer, standard wood grain or solid black laminate table, edge finish will match.
- » For double-sided upholstered panels with any other solid color laminate table, edge finish will be natural exposed plywood with a clear coat finish.

OPTIONS:

- » Two non-removable pull-out whiteboards, conveniently hidden inside the unit, available for additional writing surface requirements.
Note: not available with monitor-ready mounting option or upholstered panels.
- » Side-mount power unit and monitor-ready mounting options available
- » Select from PX3 and PX4 power units for side placement. Refer to page 3 for details.
- » Monitor-ready mounting option available on veneer, laminate or whiteboard panel surfaces and features an upper PB5 power unit, together with PB5 lower side-mount power unit. Monitor and mount not included.
- » Monitor placement must be identified (e.g. valet table, right as facing).
- » PB5 power unit includes two outlets, two USB charging ports and one HDMI jack.
- » Maximum monitor size is 40" for 54" wide unit and 50" for 63" wide unit.
- » Electrical cord extends 55" from bottom of unit and can be fed into the exit hole when not in use.

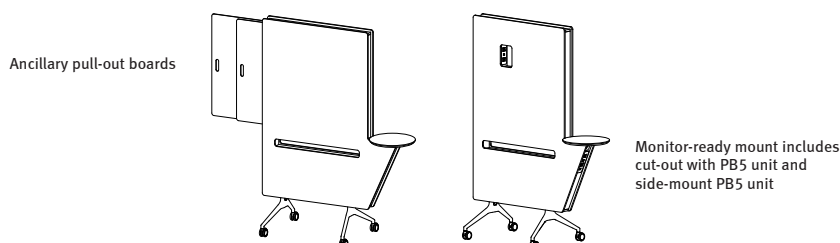

FLIRT® MULTI-PURPOSE EASELS // DESIGNED BY 5D STUDIO

ORDERING NOTES:

- » Specify surface material facing valet table on the right first, followed by the surface material on the reverse side.
- » Surface material finish, facing valet table on right side: Veneer (-V), Laminate (-L), Magnetic Laminate (-ML) or Whiteboard (-W).

ORDERING REQUIREMENTS:

- » Model number
- » Surface material finish, facing valet table on right side
- » Surface material finish, facing valet table on left side
- » Table wood species
- » Table wood finish
- » Metal leg finish

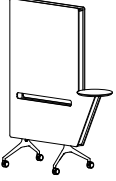
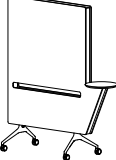
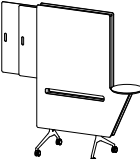
		LIST
 <p>6990-395471-(-)-()</p>	<p>54" Wide M.A.T.E. Veneer, Laminate or Whiteboard Panels W 54 D 26¹/₄ H 71 Surface Area 39" Wide Panel Thickness 4¹/₈ 104 lbs.</p>	4920
 <p>6990-486371-(-)-()</p>	<p>63" Wide M.A.T.E. Veneer, Laminate or Whiteboard Panels W 63 D 26¹/₄ H 71 Surface Area 48" Wide Panel Thickness 4¹/₈ 116 lbs.</p>	5696
 <p>6991-395471-(-)-()</p>	<p>54" Wide M.A.T.E. with Pull-Out Whiteboards Veneer, Laminate or Whiteboard Panels W 54 D 26¹/₄ H 71 Surface Area 39" Wide Panel Thickness 4¹/₈ 126 lbs.</p>	6685

OPTIONS

-PFM02	Premium Metal Leg Finish	101
-PFW05	Premium Wood Finish	75
-MR1*	Monitor Ready Mounting on Surface with Valet Table Placement on Right Side, as facing	1444
-MR2*	Monitor Ready Mounting on Surface with Valet Table Placement on Left Side, as facing	1444
-PX3-()	Power Matrix 3 (one power, one USB-A, one USB-C)	472
-PX4-()	Power Matrix 4 (dual power, one USB-A, one USB-C)	494

*Includes two PB5 power units. Not available with pull-out whiteboards.

Note: For power matrix faceplate, please specify black (-B) or white (-W) finish.

FLIRT® MULTI-PURPOSE EASELS // DESIGNED BY 5D STUDIO

ORDERING REQUIREMENTS:

- » Model number
- » Upholstery selection
- » Table wood species
- » Table wood finish
- » Metal leg finish
- » Options, as applicable

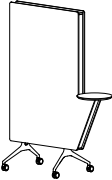
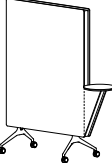
MODEL NUMBER	PRODUCT SPECIFICATIONS	FABRIC GRADES									
		COM	A	1	2	3	4	5	6	7	8
 <p>6990-395471-U-U</p>	<p>54" Wide M.A.T.E. Upholstered Panels, Both Sides W 54 D 26¹/₄ H 71 Surface Area 39" Wide Panel Thickness 4¹/₈ 3³/₄yds. 104 lbs.</p>	4078	4307	4423	4495	4607	4735	4851	4971	5080	5211
 <p>6990-486371-U-U</p>	<p>63" Wide M.A.T.E. Upholstered Panels, Both Sides W 63 D 26¹/₄ H 71 Surface Area 48" Wide Panel Thickness 4¹/₈ 4¹/₂yds. 116 lbs.</p>	4723	4998	5137	5223	5358	5511	5650	5794	5925	6082

OPTIONS		
-PFM02	Premium Metal Leg Finish	101
-PFW05	Premium Wood Finish	75
-PX3-()	Power Matrix 3 (one power, one USB-A, one USB-C)	472
-PX4-()	Power Matrix 4 (dual power, one USB-A, one USB-C)	494

Note: For power matrix faceplate, please specify black (-B) or white (-W) finish.

FLIRT® MULTI-PURPOSE EASELS // DESIGNED BY 5D STUDIO

ORDERING REQUIREMENTS:

- » Model number
- » Upholstery selection
- » Panel surface finish
- » Table wood species
- » Table wood finish
- » Leg finish
- » Options, as applicable

Note: When specifying, the first option code reflects placement in relation to the right side of the valet table, as facing. Second option code identifies panel material on the opposing side, with the valet table on the left, as facing.

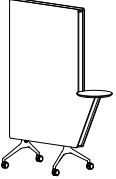
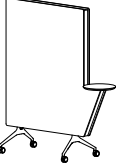
MODEL NUMBER	PRODUCT SPECIFICATIONS	FABRIC GRADES										
		COM	A	1	2	3	4	5	6	7	8	
 6990-395471(-)(-)	54" Wide M.A.T.E. Upholstered Panel One Side Veneer, Laminate or Whiteboard Panel on Flip Side W 54 D 26 ¹ / ₄ H 71 Surface Area 39" Wide Panel Thickness 4 ¹ / ₈ 2 yds. 104 lbs.	Veneer (-V)	4498	4620	4682	4720	4780	4848	4910	4974	5032	5102
		Laminate (-L) Magnetic Laminate (-ML) Upholstered (-U) Whiteboard (-W)										
 6990-486371(-)(-)	63" Wide M.A.T.E. Upholstered Panel One Side Veneer, Laminate or Whiteboard Panel on Flip Side W 63 D 26 ¹ / ₄ H 71 Surface Area 48" Wide Panel Thickness 4 ¹ / ₈ 2 ³ / ₄ yds. 116 lbs.	Veneer (-V)	5208	5376	5461	5514	5596	5690	5775	5863	5943	6039
		Laminate (-L) Magnetic Laminate (-ML) Upholstered (-U) Whiteboard (-W)										

OPTIONS		
-PFM02	Premium Metal Leg Finish	101
-PFW05	Premium Wood Finish	75
-MR1*	Monitor Ready Mounting on Surface with Valet Table Placement on Right Side, as facing	1444
-MR2*	Monitor Ready Mounting on Surface with Valet Table Placement on Left Side, as facing	1444
-PX3(-)	Power Matrix 3 (one power, one USB-A, one USB-C)	472
-PX4(-)	Power Matrix 4 (dual power, one USB-A, one USB-C)	494

*Includes two PB5 power units. Not available with pull-out whiteboards.

Note: For power matrix faceplate, please specify black (-B) or white (-W) finish.

FLIRT® MULTI-PURPOSE EASELS // DESIGNED BY 5D STUDIO

DIVIDER SCREENS PRODUCT FEATURES:

- » Available in two widths with overall height of 71".
- » Material options include maple, walnut and white oak veneer, laminate, magnetic laminate, upholstered with tackable surface or whiteboard, in any combination.
- » All standard wood finishes, excluding MA0915 Ebony Maple, available on selected wood species.
- » Premium wood finish upcharge applies to the following wood finishes. Refer to options section for pricing.
 - Super Matte Sable Maple
 - Alabaster Oak
 - Super Matte Sable Oak
- » For custom wood finishes, please add one-time upcharge of \$472 List per color per order.
- » Laminate available in all standard laminates.
- » For custom laminates, add \$590 List per color per order. Pre-approval required, please contact client services.
- » Panels specified with veneer or standard wood grain and solid black laminate, panel edge finish will match, unless otherwise specified.
- » Panels specified with all other solid color laminates, magnetic laminate or whiteboard, panel edge finish will be natural exposed plywood with a clear coat finish.
- » Vinyl, polyurethane and leather upholstery not available.
- » Please refer to page 38 for two-tone upholstery examples (different fabrics for each side), yardage requirements and pricing.
- » Center section (portion between panels) is finished in white laminate as standard. Black laminate available, please specify.
- » Die-cast aluminum legs available in standard and premium metal finishes and feature four locking casters.

OPTIONS:

- » Monitor-ready mounting option available on veneer, laminate or whiteboard panel surfaces and features a PX4 power unit.
- » **When specifying, select appropriate option code based on the applicable panel material side (e.g. #6995-3971-V-WB-MR3, indicates the mount will be applied to the veneer side of the screen vs. #6995-3971-V-WB-MR4, which indicates the mount will be on the whiteboard panel side).**
- » PX4 unit features two outlets, one USB-A and one USB-C charging port.
- » Maximum monitor size is 40" for 54" wide unit and 50" for 63" wide unit.
- » Electrical cord extends 55" from bottom of unit and can be fed into the exit hole when not in use.

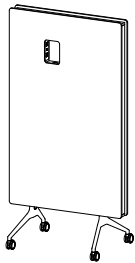

Monitor-ready mount includes cut-out with PX4 unit.

FLIRT® MULTI-PURPOSE EASELS // DESIGNED BY 5D STUDIO

ORDERING NOTES:

» Specify surface material on both sides: Veneer (-V), Laminate (-L), Magnetic Laminate (-ML) or Whiteboard (-W).

ORDERING REQUIREMENTS:

- » Model number
- » Surface material finishes
- » Metal leg finish

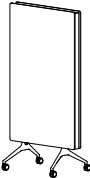
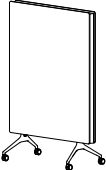
		LIST
<p>6995-3971-(-)(-)</p> 	<p>39" Wide Divider Screen Veneer, Laminate or Whiteboard Panels W 39 D 26¹/₄ H 71 Panel Thickness 4¹/₈ 76 lbs.</p>	4572
<p>6995-4871-(-)(-)</p> 	<p>48" Wide Divider Screen Veneer, Laminate or Whiteboard Panels W 48 D 26¹/₄ H 71 Panel Thickness 4¹/₈ 88 lbs.</p>	4912

OPTIONS

-PFM02	Premium Metal Leg Finish	101
-PFW05	Premium Wood Finish	75
-MR3*	Monitor Ready Mounting Placement on Panel Material Specified First	520
-MR4*	Monitor Ready Mounting Placement on Panel Material Specified Second	520

*Includes one PX4 power unit

FLIRT® MULTI-PURPOSE EASELS // DESIGNED BY 5D STUDIO

ORDERING REQUIREMENTS:

- » Model number
- » Upholstery selection
- » Metal leg finish
- » Options, as applicable

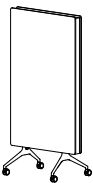
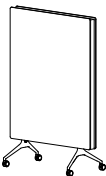
MODEL NUMBER	PRODUCT SPECIFICATIONS	FABRIC GRADES									
		COM	A	1	2	3	4	5	6	7	8
6995-3971-U-U 	39" Wide Divider Screen Upholstered Panels, Both Sides W 39 D 26 ¹ / ₄ H 71 Panel Thickness 4 ¹ / ₈ 3 ³ / ₄ yds. 76 lbs.	3563	3792	3908	3980	4092	4220	4336	4456	4565	4696
6995-4871-U-U 	48" Wide Divider Screen Upholstered Panels, Both Sides W 48 D 26 ¹ / ₄ H 71 Panel Thickness 4 ¹ / ₈ 3 ³ / ₄ yds. 88 lbs.	3869	4098	4214	4286	4398	4526	4642	4762	4871	5002
OPTIONS											
-PFM02	Premium Metal Leg Finish	101									

FLIRT® MULTI-PURPOSE EASELS // DESIGNED BY 5D STUDIO

ORDERING REQUIREMENTS:

- » Model number
- » Upholstery selection
- » Panel surface finish
- » Metal leg finish
- » Options, as applicable

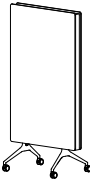
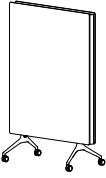
MODEL NUMBER	PRODUCT SPECIFICATIONS	FABRIC GRADES										
		PANEL FLIP SIDE MATERIAL	COM	A	1	2	3	4	5	6	7	8
6995-3971-U(-) 	39" Wide Divider Screen Upholstered Panel One Side Veneer, Laminate or Whiteboard Panel on Flip Side W 39 D 26 ¹ / ₄ H 71 Panel Thickness 4 ¹ / ₈ 2 yds. 76 lbs.	Veneer (-V)	4068	4190	4252	4290	4350	4418	4480	4544	4602	4672
		Laminate (-L) Magnetic Laminate (-ML) Whiteboard (-W)										
6995-4871-U(-) 	48" Wide Divider Screen Upholstered Panel One Side Veneer, Laminate or Whiteboard Panel on Flip Side W 48 D 26 ¹ / ₄ H 71 Panel Thickness 4 ¹ / ₈ 2 yds. 88 lbs.	Veneer (-V)	4391	4513	4575	4613	4673	4741	4803	4867	4925	4995
		Laminate (-L) Magnetic Laminate (-ML) Whiteboard (-W)										

OPTIONS		
-PFM02	Premium Metal Leg Finish	101
-PFW05	Premium Wood Finish	75
-MR4	Monitor Ready Mounting - includes one PX4 power unit (non-upholstered side only)	520

FLIRT® MULTI-PURPOSE EASELS // DESIGNED BY 5D STUDIO

UPHOLSTERY COMBINATIONS:

- » When combining two COM fabrics, or fabrics with the same grade, add \$105 List per unit.
- » When combining different grades of fabric, price will be based on the highest grade specified.
- » Two-tone upholstery examples and yardage requirements for the most common combinations are listed below. Additional combinations available, please contact client services for yardage requirements and pricing.
- » Note: Yardage amounts are based on fabric which is plain (i.e. non-directional) and a full 54" wide.
- » Appropriate upholstery code must be included.

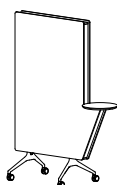

Code FL4

Model
6990-54-U-U

COM Requirement
Single Panel = 2 yds.

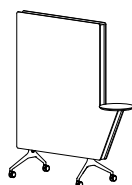

Code FL5

Model
6990-63-U-U

COM Requirement
Single Panel = 2³/₄ yds.

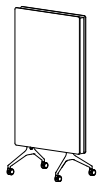

Code FL6

Model
6995-39-U-U

COM Requirement
Single Panel = 2 yds.

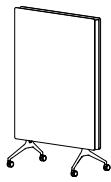

Code FL7

Model
6995-48-U-U

COM Requirement
Single Panel = 2 yds.