



RUCKUS[®] COLLECTION

PRICE LIST

EFFECTIVE MARCH 31, 2026
800.424.2432

Contents

Refer to KI Terms & Conditions document or visit ki.com.



Contents

Refer to KI Terms & Conditions document or visit ki.com.

Ordering Customer's Own Material (C.O.M.) Upholstery Information	3
Ruckus® Seating and Desking	
Recommended Classroom Seating and Worksurface Heights	4
Ruckus® Seating	
Technical Specifications	5
Product Color Options	8
Ruckus® Cantilever Desk	
Technical Specifications	9
Product Color Options	12
Ruckus® Mobile Lectern	
Technical Specifications	13
Product Color Options	15
Ruckus® Stacking Desk	
Technical Specifications	16
Product Color Options	18
Ruckus® Post-Leg Desk and Activity Table	
Technical Specifications	19
Product Color Options	43
Ruckus® Worktable	
Technical Specifications	44
Product Color Options	48
Ruckus® Cubby and Bookcase	
Technical Specifications	49
Product Color Options	52
Ruckus® Tote Storage	
Technical Specifications	53
Product Color Options	56
Ruckus® Whiteboards	
Technical Specifications	57
Product Color Options	61
Ruckus® Seating (Freight Excluded Pricing)	
Four-Leg Chair	62
Stack Chair with Glides	64
Stack Chair with Casters	66
Stool with Glides	68
Stool with Casters	70
Task Chair	72
Ruckus® Mobile Lectern (Freight Excluded Pricing)	
Mobile Lectern	73
Ruckus® Cantilever Desk (Freight Excluded Pricing)	
Desk	75
ADA Desk	77
Ruckus® Stacking Desk (Freight Excluded Pricing)	
Rounded Corner	78
Square Corner	79
Ruckus® Post-Leg Desk (Freight Excluded Pricing)	
3/4" Top - 73P Edge	80
1-1/4" Top - 74P Edge	86
Ruckus® Desk Accessories (Freight Excluded Pricing)	92
Ruckus® Activity Table (Freight Excluded Pricing)	
3/4" Top - 73P Edge	93
1-1/4" Top - 74P Edge	95
Accessories	120
Ruckus® Worktable (Freight Excluded Pricing)	121

Accessories	131
Ruckus® Storage (Freight Excluded Pricing)	
Bookcase	132
Cubbies	133
Totes	136
Totes with Laminate Top	144
Storage Accessories	152
Ruckus® Whiteboards (Freight Excluded Pricing)	156
Accessories	157
Ruckus® Seating (Delivered Pricing)	
Four-Leg Chair	158
Stack Chair with Glides	160
Stack Chair with Casters	162
Stool with Glides	164
Stool with Casters	166
Task Chair	168
Ruckus® Mobile Lectern (Delivered Pricing)	
Mobile Lectern	169
Ruckus® Cantilever Desk (Delivered Pricing)	
Desk	171
ADA Desk	173
Ruckus® Stacking Desk (Delivered Pricing)	
Rounded Corner	174
Square Corner	175
Ruckus® Post-Leg Desk (Delivered Pricing)	
3/4" Top - 73P Edge	176
1-1/4" Top - 74P Edge	182
Ruckus® Desk Accessories (Delivered Pricing)	188
Ruckus® Activity Table (Delivered Pricing)	
3/4" Top - 73P Edge	189
1-1/4" Top - 74P Edge	191
Accessories	216
Ruckus® Worktable (Delivered Pricing)	217
Accessories	227
Ruckus® Storage (Delivered Pricing)	
Bookcase	228
Cubbies	229
Totes	232
Totes with Laminate Top	240
Storage Accessories	248
Ruckus® Whiteboards (Delivered Pricing)	252
Accessories	253



How to Specify

As a standard procedure, KI applies seating upholstery as swatched by the textile distributor. Reference distributor's website. Upholstery that is required to be applied differently than is swatched, will need a Product Modification Request written specifying the direction the upholstery is to be applied.

Seating upholstery requiring specific positioning of intricate patterns or patterns repeats on seats and backrests, will need a Product Modification Request written including a sketch noting the specific requirements, as in Diagram A.

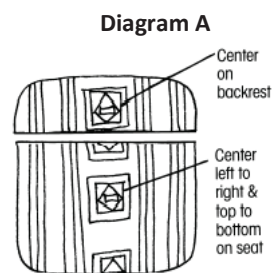

When directional or patterned fabrics are used, they often require more yardage than solid colors.

C.O.M. must be supplied in continuous yardage.

C.O.M. yardage requirements accompanying products in the pricing section are for 10 chairs/seats or less, 54" wide nondirectional material. On larger orders, less material is required.

Leather hides must be a minimum of 50 square feet of usable material. The outer edges cannot be calculated as square feet or yardage. To determine square footage, multiply unit yardage by 18 square feet to obtain the total square footage required per unit.

For exact production yardage requirements, call 1-800-424-2432, ext. 2707.

Production

Customer's upholstery must be approved prior to acceptance for production.

C.O.M. not received into the appropriate facility 3 weeks prior to acknowledged delivery date may go on hold. See KI C.O.M. Shipping Location listing for the correct facility address by product.

Testing

When KI requires testing, actual yardage to upholster one chair may be required. The C.O.M. Specialist will confirm model and fabric testing requirements when applicable.

Approved test samples will be applied to the order or will be held for 6 months. After 6 months, the sample will no longer be applied to your order. For all product testing, send fabric samples to the manufacturing facility. See KI C.O.M. Shipping Location listing for the correct facility address by product.

All C.O.M. must be labeled with the KI product order number and customer purchase order number.

Treated Materials

If C.O.M. requires processing such as a stain resistance treatment or acrylic backing, it may shrink. To prevent delays in delivery or back ordering due to shrinkage, please have your processor verify measurement after processing and assure adequate yardage shipped.

Split Orders

If a portion of the shipment which does not require C.O.M. application is to be processed and shipped early, KI will enter the order immediately at your request. These split shipments are subject to minimum order changes.

Excess Upholstery Material

KI will dispose of excess upholstery material at the time of shipment unless expressly requested to return it with the product shipment.

Cancelled or Changed Orders

KI assumes no responsibility for extra C.O.M. due to a change of upholstery or cancellation of an order. If it the customer's responsibility to arrange for return of the material.

Contact the C.O.M. Specialist at 1-800-424-2432, ext. 2707, with questions or to request a split order.

C.O.M. SHIPPING LOCATION

Architectural Walls Evoke..... MN Genius..... MN Casegoods Aristotle.....MN Likha.....MN Classroom Furniture Cogni GB Intellect Wave GB Learn2.....GB Ruckus..... GB Desking 700 SeriesKP Balance MN Genesis MN TrueKP Universal MN WorkZone MN Files & Storage 700 Series..... GB ConnectionBW U-Series GB Tattoo.....BW Fixed Seating Concerto.....BW Single Pedestal GB Jury Base GB Lancaster.....BW Sequence GB University GB	Panel Systems All Terrain.....KP Balance MN Universal MN Wireworks MN Unite..... MN Residence Hall Furniture RoomScape MN Screens All Terrain.....KP Connection Zone.....BW Tributaire.....BW True/VolitionKP Genesis.....KP Tattoo..... MN Universal.....BW Seating 600 Series.....BW Affina HN Altus GB Apply GB Calida HN Cascha VT Civara VT Clamber HN Cogni GB Diem OM Doni GB GladlyVQ Grazie GB Hub HN Impress OM	Impress Ultra OM Intellect Wave GB JessaHN JubileeVQ Katera..... GB Kurv Benches.....HN Learn2.....GB LimeLite..... GB Lyra HN Medical & Laboratory Stools..... OM MyPlace HN MyWay HN Oath GB Opt4..... GB Pilot OM PromenadeBW Ruckus..... GB Sela HN Sift GB Signia..... OM Soltice Metal HN Soltice..... HN Sonrisa HN Strive GB SwayBW Tattoo..... HN Torsion-on-the-Go! GB Torsion Air GB Zeker HN Zentori VT Zoetry HN
---	--	---



KI C.O.M. Manufacturing Site Addresses:

BW KI Bonduel Attn: COM Storage 204 West South St. Bonduel, WI 54107	HN KI High Point Attn: COM Storage 217 Feld Avenue High Point, NC 27263	MN KI Manitowoc Attn: COM Storage 1400 S. 41st St. Manitowoc, WI 54220	VQ KI Attn: COM Fabrics 6892 Marlin Circle La Palma, CA 90623
GB KI Green Bay Attn: COM Storage 1687 Westminster Drive - Gate 3 Green Bay, WI 54302	KP KI Pembroke Attn: COM Storage 1000 Olympic Dr. Pembroke, Ontario K8A6X7	OM KI Attn: COM Storage 1110 S. Mildred Ave. Ontario, CA 91761	VT KI Attn: COM Storage 2803 South Taylor Drive Sheboygan, WI 53081

PRODUCT SPECIFICATIONS ■

Ruckus™ Seating

February 2025

TECHNICAL SPECIFICATIONS

Description

Ruckus promotes student movement through its unique design. It's generously sized seating encourages an "as you like it" sitting experience. The chair back shape includes integral armrests, which are also engineered to function as a support surface.

Seat & Backrest

Both the seat and backrest shell are made of static-free high-impact polypropylene. Colorfastness is ensured through complete color impregnation throughout the molded part. Textured on both sides with a contrasting texture pattern on the seat. Ergonomic handle molded into the chair backrest for ease of mobility. Seat and backrest fasten to the frame with six M6 x 18 mm BosScrew screws.

Optional Upholstered Seat

Upholstered seats have partially exposed polypropylene surfaces. Molded urethane foam is attached to an injection-molded polypropylene liner board, then upholstered using a draw-string process and fastened to an inner shell with screws. Seat foam is molded nominal 1" thickness.

Frames

4-Leg, Stack, Stool and Task chair frames are constructed with 1" outside diameter 13-gauge steel tubing, welded to 13-gauge steel plates and 1/4" wire. Frame is nickel-chrome plated or finished in powder-coat paint after all welding processes are complete.

Glides

Stack, Stool & 4-Leg Chairs - Swivel-type polished zinc-plated steel, nylon plastic, or felt glides. KI recommends consulting with the floor manufacturer for specific glide recommendations.

Note: Felt glides add 1/4" to the overall height range.

Task Chair - Optional Bell glides (2" high) made of high impact plastic also available. Black only.

Note: Bell glides add 1/4" to the overall height range.

Casters

Carpet Casters Option - 50 mm double wheels of high-impact thermoplastic. High-impact plastic frame. Black finish only. Hard Floor Casters Option - 50 mm double wheels of soft plastic.

High-impact plastic frame. Black finish only.

Task Chair

Pneumatic Height Adjustment - Lever-activated pneumatic cylinder enables seat-height adjustment from 16 1/2" to 21 1/4". Five-blade base - 28" injection molded, 30% fiberglass reinforced nylon 5-blade base. Available in Black or Warm Gray.

Bookbag Rack

Stack Chair Frame - Optional bookbag rack is a welded framework of 1/4" diameter solid wire welded to four 1/8" thick plates. Fastened to stackable chair frame with four #10 screws. Bookbag rack will be nickel-chrome plated or finished in powder-coat paint after all welding processes are complete.

Compliance

Ruckus chair components originate from ISO 9000, ISO 9001 or ISO 9002 registered facilities. Ruckus seating is designed and manufactured to meet or exceed required ANSI/BIFMA X5.1-2011 Seating.

DIMENSIONS

General Dimension			
Seat Height	A (Seat Depth 1)	B (Seat Width)	C (Seat Depth 2)
15"	18.8"	22.3"	16.7"
18"	18.8"	22.3"	16.7"

Chair Overall Dimension							
Seat Height	D (Width 1)	E (Width 2)	F (Depth 1)	G (Depth 2)	H (Height)	I (Seat Height)	J (Backrest Height)
15"	22.8"	28"	22.8"	29"	25.5"	15"	10.4"
15" (Upholstered Seat)	22.8"	28"	22.8"	29"	25.5"	16.3"	10.4"
18"	22.8"	28"	22.8"	29"	29.5"	18"	11.4"
18" (Upholstered Seat)	22.8"	28"	22.8"	29"	29.5"	19.3"	11.4"
24" Stool	22.8"	28"	22.8"	29"	35.5"	24"	11.4"
24" Stool (Upholstered Seat)	22.8"	28"	22.8"	29"	35.5"	25.3"	11.4"
30" Stool	22.8"	28"	22.8"	29"	41.5"	30"	11.4"
30" Stool (Upholstered Seat)	22.8"	28"	22.8"	29"	41.5"	31.3"	11.4"
Task Chair	22.8"	28.25"	22.8"	27.67"	28"-32.75"	16.5"-21.25"	11.4"
Task Chair (Upholstered Seat)	22.8"	28.25"	22.8"	27.67"	28"-32.75"	17.7"-22.4"	11.4"

Note: Dimensions are consistent for both 4-Leg & Stack Chair options.

Note: Felt and Bell glides add 1/4" to the overall height range.

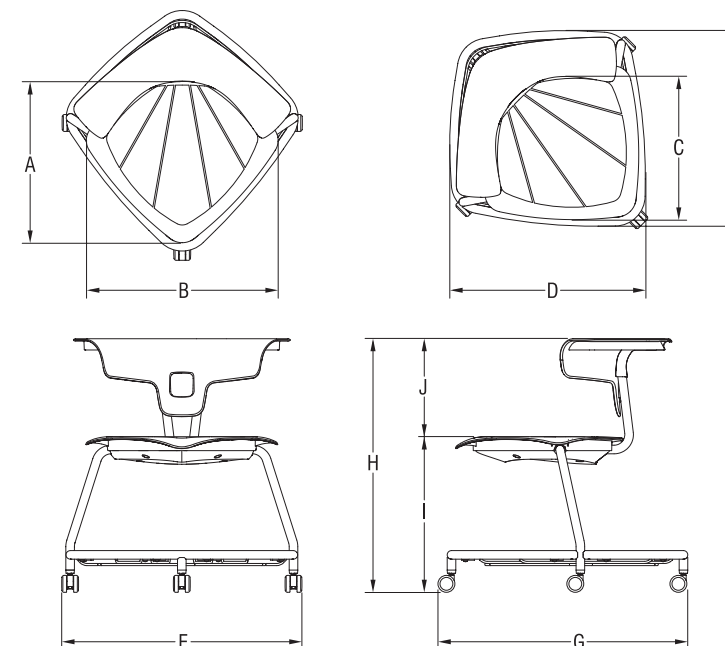



STATEMENT OF LINE

Ruckus Task Chairs



RK5100



RK5200

Ruckus 4-Leg Chairs

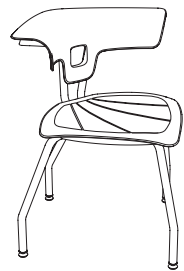

RK1100H18-NB

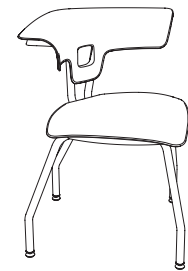

RK1200H18-NB

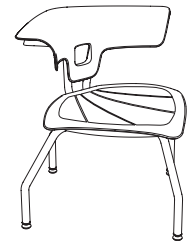

RK1100H15-NB

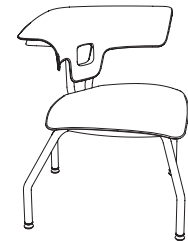

RK1200H15-NB

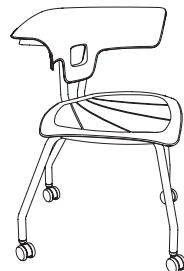

RK2100H18-NB

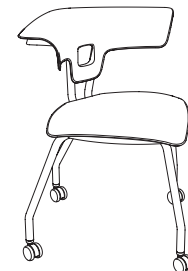

RK2200H18-NB

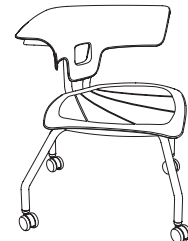

RK2100H15-NB

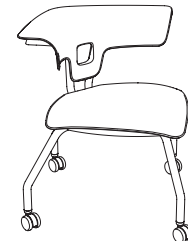

RK2200H15-NB

STATEMENT OF LINE

Ruckus Stack Chairs

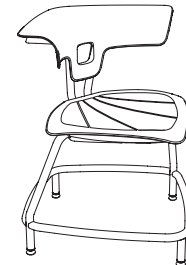

RKU100H18-NB

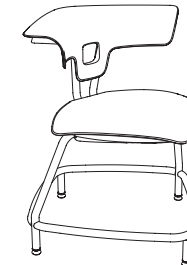

RKU200H18-NB

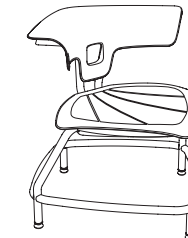

RKU100H15-NB

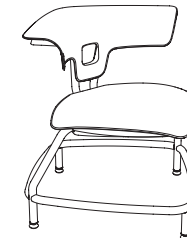

RKU200H15-NB

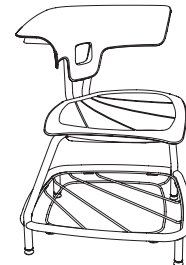

RKU100H18-BR

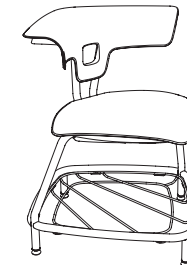

RKU200H18-BR

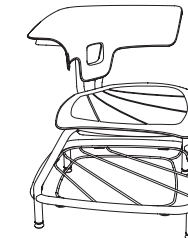

RKU100H15-BR

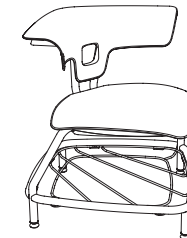

RKU200H15-BR

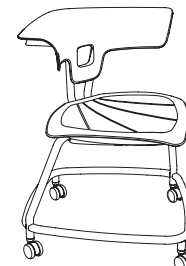

RKV100H18-NB

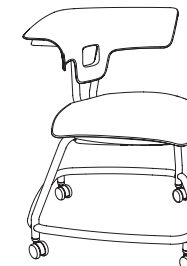

RKV200H18-NB

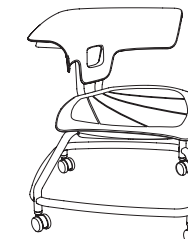

RKV100H15-NB

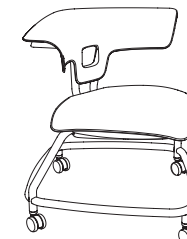

RKV200H15-NB

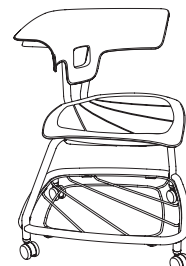

RKV100H18-BR

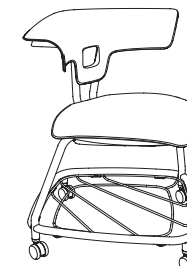

RKV200H18-BR

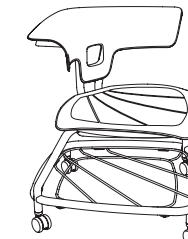

RKV100H15-BR

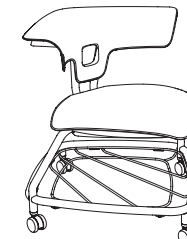

RKV200H15-BR



STATEMENT OF LINE

Ruckus Stools

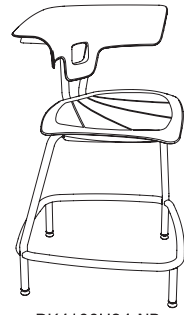

RK4100H24-NB

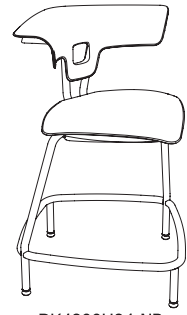

RK4200H24-NB

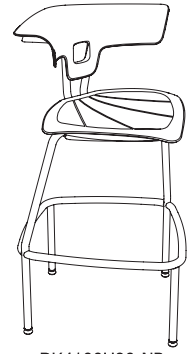

RK4100H30-NB

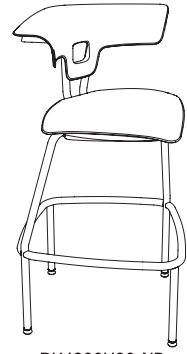

RK4200H30-NB

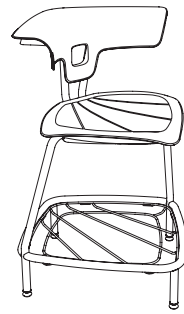

RK4100H24-BR

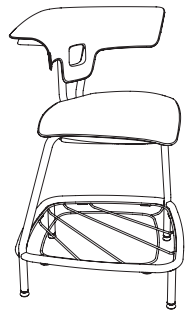

RK4200H24-BR

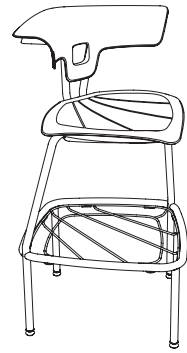

RK4100H30-BR

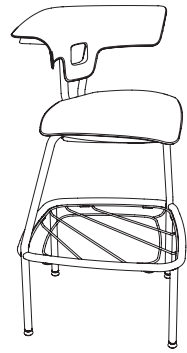

RK4200H30-BR

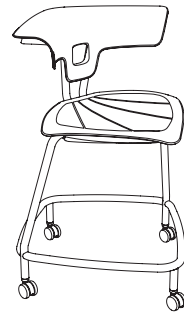

RKN100H24-NB

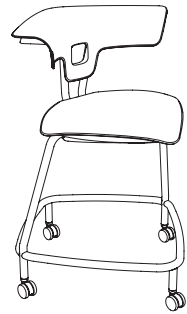

RKN200H24-NB

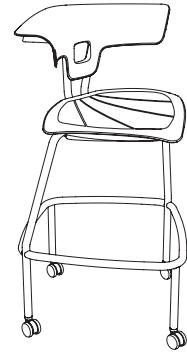

RKN100H30-NB

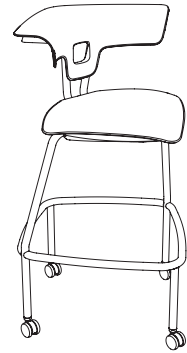

RKN200H30-NB

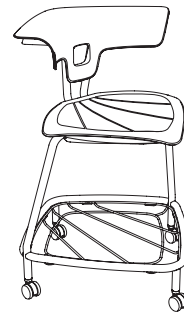

RKN100H24-BR

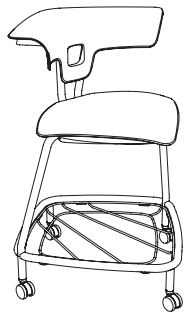

RKN200H24-BR

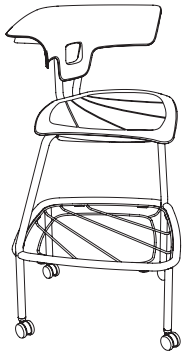

RKN100H30-BR

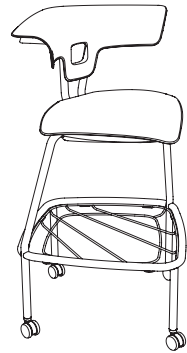

RKN200H30-BR



Frame Color

Black	BL	Poppy Red	PPR
Blue Grey	GR	Purple Haze	PPH
Bronze Metallic	ZM	Rainforest	PRQ
Cayenne	CY	Raw Jasper	PRJ
Champagne Metallic	CM	Rubber Ducky	PRK
Chrome	CH	Sand	PSA
Cool Grey	CG	Sky Blue	PSK
Cottonwood	CO	Surf's Up	PSP
Earthen Clay	EO	Tarragon	PTQ
Espresso Metallic	EY	Twilight Shadow	PTI
Everglade Shade	EX	Ultra Blue	PUB
Flannel	EV	Warm Grey	PWG
Glitz Metallic	FN	Zesty Lime	PZL
Hazy Jade	GZ		
Honey Bee	HJ	Bookbag Rack	
Light Tone	HY	Black	BRBL
Mardi Gras	LG	Blue Grey	BRGR
Misty Brown	MG	Bronze Metallic	BRZM
Nemo	MY	Cayenne	BRCY
Nordic	NE	Champagne Metallic	BRCM
Poppy Red	ND	Chrome	BRCH
Purple Haze	PR	Cool Grey	BRCG
Rainforest	PH	Cottonwood	BRCO
Raw Jasper	RQ	Earthen Clay	BREY
Rubber Ducky	RJ	Espresso Metallic	BREX
Sand	RK	Everglade Shade	BREV
Sky Blue	SA	Flannel	BRFN
Starlight Silver Metallic	SK	Glitz Metallic	BRGZ
Surf's Up	SX	Hazy Jade	BRHJ
Tarragon	SP	Honey Bee	BRHY
Twilight Shadow	TQ	Light Tone	BRLG
Ultra Blue	TI	Mardi Gras	BRMG
Warm Grey	UB	Misty Brown	BRMY
Zesty Lime	WG	Nemo	BRNE
	ZL	Nordic	BRND
		Poppy Red	BRPR
		Purple Haze	BRPH
		Rainforest	BRRQ
		Raw Jasper	BRRJ
		Rubber Ducky	BRRK
		Sand	BRSA
		Sky Blue	BRSK
		Starlight Silver Metallic	BRSX
		Surf's Up	BRSP
		Tarragon	BRTQ
		Twilight Shadow	BRTI
		Ultra Blue	BRUB
		Warm Grey	BRWG
		Zesty Lime	BRZL

Frame Color-Task Chairs

Black	BL		
Warm Grey	WG		

Casters and cylinder will always be black

Seat and Back Color-Polypropylene

Black	PBL	Starlight Silver Metallic	BRSX
Blue Grey	PGR	Surf's Up	BRSP
Cayenne	PCY	Tarragon	BRTQ
Cool Grey	PCG	Twilight Shadow	BRTI
Cottonwood	PCO	Ultra Blue	BRUB
Earthen Clay	PEY	Warm Grey	BRWG
Everglade Shade	PEV	Zesty Lime	BRZL
Flannel	PFN		
Hazy Jade	PHJ		
Honey Bee	PHY		
Light Tone	PLG		
Mardi Gras	PMG		
Misty Brown	PMY		
Nemo	PNE		
Nordic	PND		

Finish Cards

View color swatches for items listed within this document.

Paints

Plastics/Poly

Wood/Veneer

Laminates

Molded Edges

Edge Styles

Hard Plastics

Glass

Certain options referenced may not be available on GSA Schedule.



PRODUCT SPECIFICATIONS ■

Ruckus™ Desks

May 2022

TECHNICAL SPECIFICATIONS

Note: Desks are not to be stacked or nested together.

Fixed-Height Desk – Single-Post Cantilever

Frames are constructed with 2" and 1 1/4" by 14-gauge steel tubing welded to a 7-gauge steel plate. Frame is nickel-chrome plated or finished in powder-coat paint after all welding processes are complete. The 1 1/4" horizontal tubing is capped with a plastic plug (offered in black only).

The worksurface is attached to the top-support plate using eight, #12 x 7/8" wood screws. Product is shipped fully assembled, one unit per carton.

Pneumatic Height-Adjustable Desk – Single-Post Cantilever

The top of the worksurface adjusts between 27 1/4" and 41 1/2" from the floor by activating a pneumatic cylinder using a lever located on the non-user side of the worksurface.

The desk base consists of a lower frame weldment and adjustable upper column assembly. The lower frame is constructed with 2" and 1 1/4" by 14-gauge steel tubing and can be nickel-chrome plated or finished in powder-coat paint after all welding processes are complete. The 1 1/4" horizontal tubing is capped with a plastic plug (offered in black only).

The adjustable upper column assembly is constructed of a 3" diameter aluminum extrusion and is capped using a cast aluminum support flange attached by six, 1/4"-20 x 3/4" screws. The upper column assembly is finished in powder-coat paint. Nickel-chrome plating is not available on the upper column assembly. Upper assembly will be painted Starlight Silver when nickel-chrome plating is specified for the lower frame. The support flange is finished in black powder-coat paint.

The worksurface is attached to the support flange using eight, #12 x 7/8" wood screws. Product is shipped fully assembled, one unit per carton.

The pneumatic cylinder includes a locking feature to prevent vertical movement when any force is applied to the worksurface and the cylinder is not actuated.

The weight capacity with accessories (bookrack and cup holder) is less than 15 lb. Weight capacity is 20 lb when accessories are not specified. Capacity represents the total amount of weight the cylinder can lift without assistance from the user.

Set Screw Height-Adjustable Desk – Single-Post Cantilever

The top of the worksurface adjusts between 27 1/4" and 41 1/2" from the floor, in 1" increments by locking with a 1/4"-20 x 1/2" dog point set screw.

The desk base consists of a lower frame weldment and adjustable upper column assembly. The lower frame is constructed with 2" and 1 1/4" by 14-gauge steel tubing and can be nickel-chrome plated or finished in powder-coat paint after all welding processes are complete. 1 1/4" horizontal tubing is capped with a plastic plug (offered in black only).

The adjustable upper column assembly is constructed of a 3" diameter aluminum extrusion and is capped using a cast aluminum support flange attached by six, 1/4"-20 x 3/4" screws. The upper column assembly is finished in powder-coat paint. Nickel-chrome plating is not available on the upper column assembly. Upper assembly will be painted Starlight Silver when nickel-chrome plating is specified for the lower frame. The support flange is finished in black powder-coat paint.

The worksurface is attached to the support flange using eight, #12 x 7/8" wood screws. Product is shipped fully assembled, one unit per carton.

TECHNICAL SPECIFICATIONS

ADA Set Screw Height-Adjustable Desk – Single-Post Cantilever

The top of the worksurface adjusts between 27 1/4" and 31 1/4" from the floor, in 1" increments by locking with a 1/4"-20 x 1/2" dog point set screw.

The desk base consists of a lower frame weldment and adjustable upper column assembly. The lower frame is constructed with 2" and 1 1/4" by 11-gauge & 14-gauge steel tubing and can be nickel-chrome plated or finished in powder-coat paint after all welding processes are complete. 1 1/4" horizontal tubing is capped with a plastic plug (offered in black only).

The adjustable upper column assembly is constructed of a 3" diameter aluminum extrusion and is capped using a cast aluminum support flange attached by six, #12-24 x 3/4" screws. The upper column assembly is finished in powder-coat paint. Nickel-chrome plating is not available on the upper column assembly. Upper assembly will be painted Starlight Silver when nickel-chrome plating is specified for the lower frame. The support flange is finished in black powder-coat paint.

A steel plate is attached to the bottom of the worksurface using fourteen, #12 x 3/4" wood screws. The steel plate and worksurface is then attached to the support flange using eight, #12-24 x 3/4" screws. Product is shipped fully assembled, one unit per carton.

Rolling Base Model (wheelbarrow)

Rolling base model includes two rollers located on the non-user side of the frame, with two swivel glides located on the user side for ease of mobility. Roller will be constructed of a two-piece molded polycarbonate housing with steel axle, supporting a 1 1/4" diameter wheel constructed of high impact styrene and secured to base frame with a 1/4"-20 x 5/8" screw. Cantilever frame will include cutouts to encapsulate roller assembly. Roller assembly is offered in black only. Swivel-type glides are polished zinc-plated steel with nylon plastic, or felt feet surfaces. KI recommends consulting with the floor manufacturer for specific glide recommendations. **Note:** Felt glides increase product height by 1/4".

Note: Glides cannot be swapped with rollers or rollers with glides.

Worksurfaces

Worksurface top consists of high-density particleboard core covered with .030" high-pressure laminate top and a .020" phenolic backing sheet and 73P polypropylene edge with a finished top thickness of 13/16". Worksurface includes a curved front comfort curve on user side and 2 3/8" radius corners. Worksurface measures 20" x 30". ADA worksurfaces measure 25" x 36".

Glides

Swivel-type glides are polished zinc-plated steel with nylon plastic, or felt feet surfaces. KI recommends consulting with the floor manufacturer for specific glide recommendations. **Note:** Felt glides increase product height by 1/4". **Note:** Glides cannot be swapped with rollers or rollers with glides.

Book Bag Hook

Optional book bag hook is formed from 1/4" solid wire rod. Chrome finish provides long lasting wear resistance. Hook fastens to underside of laminate top with two #12 x 3/4" Phillips pan-head screws. Book bag hook is fully assembled to desk prior to shipment.

Book Basket

Optional book basket is formed from 1/4" solid wire rod. Book basket can be nickel-chrome plated or finished in powder-coat paint after all welding processes are complete. Measures 24 1/2" wide by 13" deep by 3 1/4" high. Fastens to underside of laminate top with six #12 x 3/4" Phillips pan-head screws. Book basket is fully assembled to desk prior to shipment.

Cup Holder

Optional cup holder is made of 11-gauge steel and includes a 3" diameter cutout for drinks. Offered in Starlight Silver only. Cup holder is fully assembled to desk prior to shipment.

Compliance

Ruckus desking components originate from ISO 9000, ISO 9001 or ISO 9002 registered facilities. Ruckus desking is designed and manufactured to meet or exceed required ANSI/BIFMA X5.5-2014 Desking.



DIMENSIONS

Fixed Height - 29"

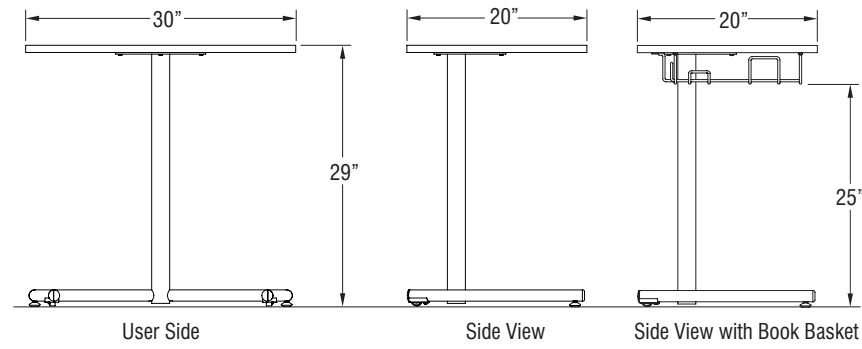

Set Screw Adjustable

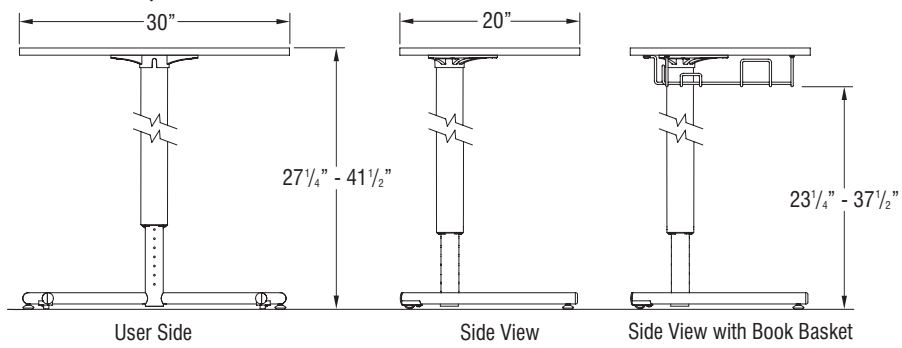

Pneumatic Adjustable

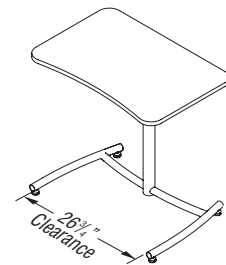
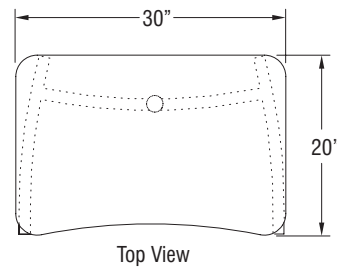
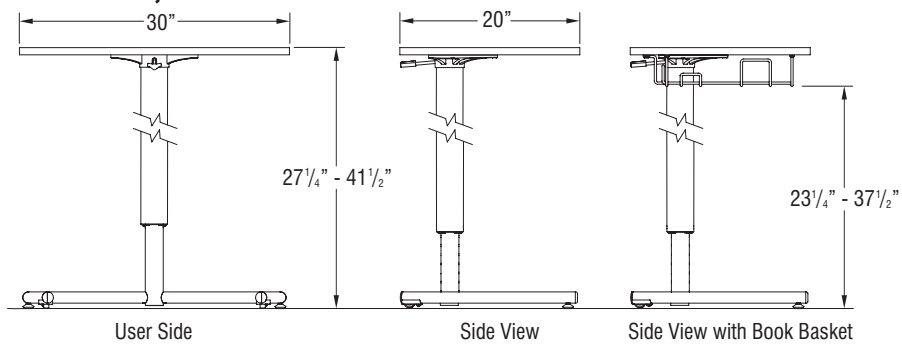

DIMENSIONS

ADA Set Screw Adjustable

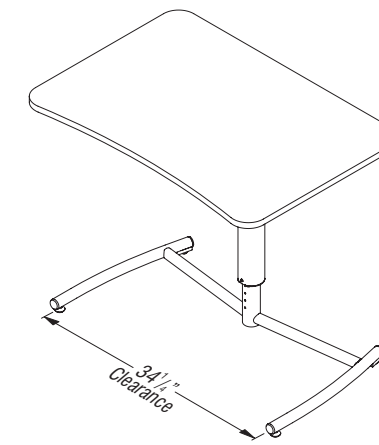
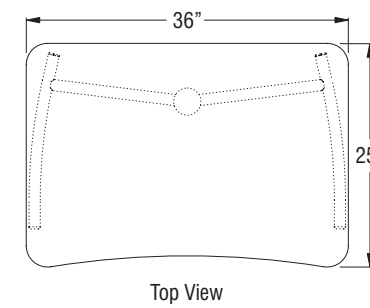
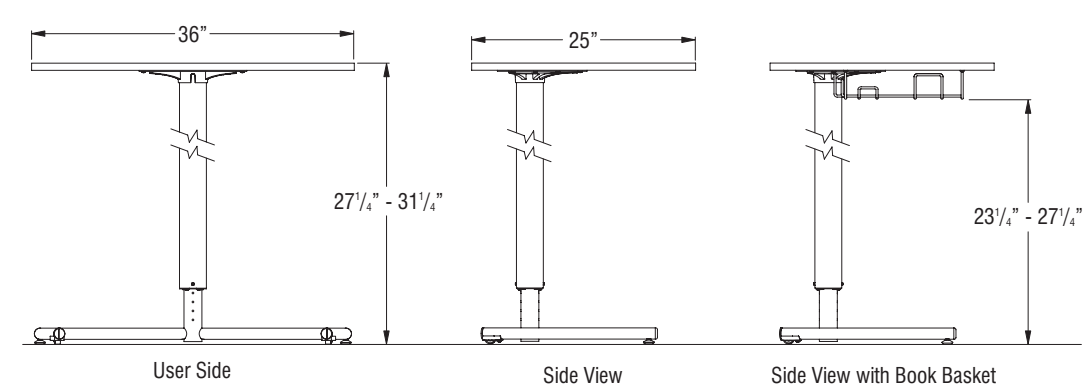



STATEMENT OF LINE

Fixed Height - 29"

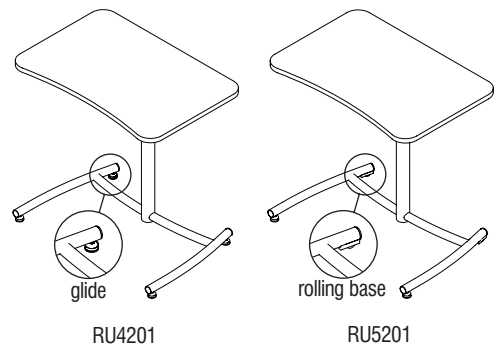

ADA Set Screw Adjustable

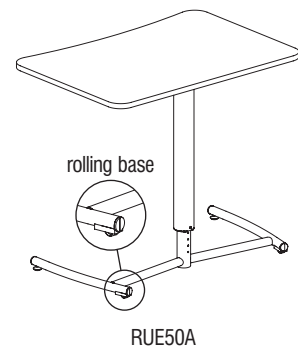

Set Screw Adjustable

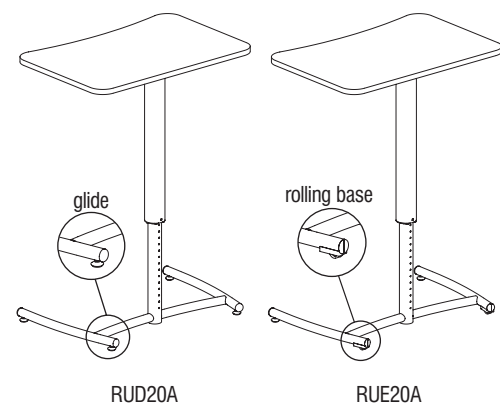

Pneumatic Adjustable

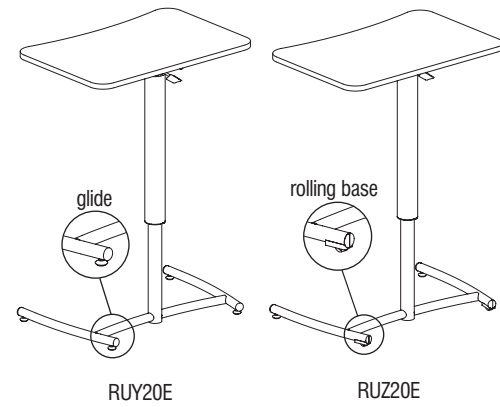



Base Color		BRMG		Pinnacle Walnut	EPW
Black	BL	Misty Brown	BRMY	Poppy Red	EPR
Blue Grey	GR	Nemo	BRNE	Rainforest	ERQ
Bronze Metallic	ZM	Nordic	BRND	Raleigh Walnut	ERW
Cayenne	CY	Poppy Red	BRPR	River Cherry	ERY
Champagne Metallic	CM	Purple Haze	BRPH	Rubber Ducky	ERK
Chrome	CH	Rainforest	BRRQ	Sand	ESA
Cool Grey	CG	Raw Jasper	BRRJ	Sky Blue	ESK
Cottonwood	CO	Rubber Ducky	BRRK	Solano Walnut	ESG
Earthen Clay	EY	Sand	BRSA	Sterling Ash	EAZ
Espresso Metallic	EX	Sky Blue	BRSK	Surf's Up	ESP
Everglade Shade	EV	Starlight Silver Metallic	BRSX	Tarragon	ETQ
Flannel	FN	Surf's Up	BRSP	Twilight Shadow	ETI
Glitz Metallic	GZ	Tarragon	BRTQ	Ultra Blue	EUB
Hazy Jade	HJ	Twilight Shadow	BRTI	Valley Forge Elm	EVF
Honey Bee	HY	Ultra Blue	BRUB	Warm Grey	EWG
Light Tone	LG	Warm Grey		White River Forest	EWR
Mardi Gras	MG	BRWG		Windsor Mahogany	EWY
Misty Brown	MY	Zesty Lime	BRZL	Zesty Lime	EZL
Nemo	NE				
Nordic	ND				
Poppy Red	PR				
Purple Haze	PH				
Rainforest	RQ				
Raw Jasper	RJ				
Rubber Ducky	RK				
Sand	SA				
Sky Blue	SK				
Starlight Silver Metallic	SX				
Surf's Up	SP				
Tarragon	TQ				
Twilight Shadow	TI				
Ultra Blue	UB				
Warm Grey	WG				
Zesty Lime	ZL				

*Additional colors may be available. Please contact KI customer service at 1-800-424-2432

Surface Finish--Grade 2 Standard Laminate		
Akira	LAK	
Black Alicante	LBY	
Black Hills Oak	LBH	
Calcutta Marble	LCQ	
Dering Forest	LDF	
Fawn Cypress	LFQ	
Ice Mist	LIM	
Markerboard White	LMK	
Valley Forge Elm	LVF	
White River Forest	LWR	

*Additional colors may be available. Please contact KI customer service at 1-800-424-2432

*For height adjustable desks when chrome is selected the lower frame will be chrome and the upper column assembly will be Starlight Silver Metallic.

*Additional colors may be available. Please contact KI customer service at 1-800-424-2432

		Edge Color for 73P Edge		Surface Finish--Grade 1 Standard Laminate	
		Akira	EAK	Beigewood	LBZ
		Beigewood	EBZ	Belair	LBQ
		Belair	EBQ	Biltmore Cherry	LBT
		Biltmore Cherry	EBT	Black	LBK
		Black	EBL	Brighton Walnut	LBW
		Black Hills Oak	EBH	Castle Oak	LCO
		Blue Grey	EGR	Cherry Storm	LCX
		Brighton Walnut	EBW	Classic Linen	LCI
		Castle Oak	ECO	Cocobala	LCC
		Cayenne	ECY	Crisp Linen	LRI
		Cherry Storm	ECX	Designer White	LDR
		Cocobala	ECC	Dove Grey	LDG
		Cool Grey	ECG	Florence Walnut	LFC
		Cumberland Walnut	ECJ	Friston Ash	LFH
		Dering Forest	EDF	Frosty White	LFW
		Designer White	EDR	Graphite Nebula	LGN
		Everglade Shade	EEV	Grey	LGE
		Fawn Cypress	EFQ	High Rise	LHE
		Flannel	EFN	Hollyberry	LHY
		Florence Walnut	EFC	Island	LID
		Friston Ash	EFH	Italian Silver Ash	LIT
		Frosty White	EFW	Kensington Maple	LKM
		Hartley Walnut	EHW	Lapis Blue	LLB
		Hazy Jade	EHJ	Monticello Maple	LMT
		Italian Silver Ash	EIT	North Sea	LNA
		Kensington Maple	EKM	Ocean	LON
		Light Tone	ELG	Pinnacle Walnut	LPW
		Mardi Gras	EMG	River Cherry	LRY
		Misty Brown	EMY	Shadow Zephyr	LSR
		Monticello Maple	EMT	Sterling Ash	LAZ
		Multiplex	EMB	Titanium Evolv	LTV
		Nemo	ENE	White Nebula	LWL
		Nordic	END	White Sand	LWN
				Windsor Mahogany	LWY

*For height adjustable desks when chrome is selected the lower frame will be chrome and the upper column assembly will be Starlight Silver Metallic.

Book Basket Color

Black	BRBL
Blue Grey	BRGR
Bronze Metallic	BRZM
Cayenne	BRCY
Champagne Metallic	BRCM
Chrome	BRCH
Cool Grey	BRCG
Cottonwood	BRCO
Earthen Clay	BREY
Espresso Metallic	BREX
Everglade Shade	BREV
Flannel	BRFN
Glitz Metallic	BRGZ
Hazy Jade	BRHJ
Honey Bee	BRHY
Light Tone	BRLG
Mardi Gras	

Finish Cards

View color swatches for items listed within this document.

Paints	Wood/Veneer	Molded Edges	Hard Plastics
Plastics/Poly	Laminates	Edge Styles	Glass

Certain options referenced may not be available on GSA Schedule.



PRODUCT SPECIFICATIONS

Ruckus™ Mobile Lectern

December 2025

TECHNICAL SPECIFICATIONS

Mobile Lectern – Single-Post Cantilever

The top of the worksurface adjusts between 28³/₄" and 42³/₄" from the floor by activating a pneumatic cylinder using a lever located on the user side of the worksurface.

The lectern base consists of a lower frame weldment and adjustable upper column assembly. The lower frame is constructed with 2" and 1¹/₄" by 14-gauge steel tubing and can be nickel-chrome plated or finished in powder-coat paint after all welding processes are complete. The 1¹/₄" horizontal tubing is capped with a plastic plug (offered in black only). Available with casters only.

The adjustable upper column assembly is constructed of a 3" diameter aluminum extrusion and is capped using a black cast zinc flange attached by six, 1/4"-20 x 1¹/₂" screws. The upper column assembly is finished in powder-coat paint. Nickel-chrome plating is not available on the upper column assembly. Upper assembly will be painted Starlight Silver when nickel-chrome plating is specified for the lower frame.

The worksurface is attached to the flange using five, #12 x 7/8" wood screws. Product is shipped fully assembled, one unit per carton.

The pneumatic cylinder includes a locking feature to prevent vertical movement when any force is applied to the worksurface and the cylinder is not actuated.

The weight capacity with accessories (modesty panel, bookrack and cup holder) is less than 15 lbs. Weight capacity is 20 lbs when accessories are not specified. Capacity represents the total amount of weight the cylinder can lift without assistance from the user.

Top

Worksurface top consists of high-density particleboard core covered with .030" high-pressure laminate top and a .020" phenolic backing sheet and 73P polypropylene edge with a finished top thickness of 1³/₁₆". Worksurface includes a curved front comfort curve on user side and 2³/₈" radius corners. Worksurface measures 20" x 30".

Casters

Casters are single wheel with a 40mm outside dimension and constructed from high-impact thermoplastic. Available with hard or soft wheel surface. Black only.

Modesty Panel

Steel modesty panels are 19" wide by 17" tall. Acrylic and felt modesty panels are 20" wide by 20" tall. See Color Addendum for available finish options for material selected. Modesty panel is fully assembled to desk prior to shipment.

Acrylic Modesty Panel

Panels are constructed of 1/4" thick Acrylite Satinice material with a velvet texture and a very fine satin surface on both sides. Modesty panels are located on the underside of the worksurface and held in place using four #10-24 x 3/4" knurled thumbscrews and two 14-gauge steel brackets.

Perforated Steel Modesty Panel

Panels are constructed of 14-gauge (.075" thick) perforated steel and finished in powder-coat paint. The modesty panel mounts to the table using integrated/welded 14-gauge (.075" thick) formed steel brackets, secured to the underside of the worksurface.

Polyester Felt Modesty Panel

Polyester felt modesty panels are constructed from a sound-absorbing, 100% polyester felt. The panels have a density of 0.5 lb/ft² and is sound absorbing tested to ASTM C423 with an NRC rating of .44 when using no air gap (A-Mount testing method) and an NRC rating of .81" with 2" air gap. The polyester felt is in accordance with ASTM-E84 and achieve a Class A Flame Spread. Modesty panels are located on the underside of the worksurface and held in place using four #10-24 x 3/4" knurled thumbscrews and two 14-gauge steel brackets.

TECHNICAL SPECIFICATIONS

Book Bag Hook

Optional book bag hook is formed from 1/4" solid wire rod. Chrome finish provides long lasting wear resistance. Hook fastens to underside of laminate top with two #12 x 3/4" Phillips pan-head screws. Book bag hook is fully assembled to desk prior to shipment.

Book Basket

Optional book basket is formed from 1/4" solid wire rod. Book basket can be nickel-chrome plated or finished in powder-coat paint after all welding processes are complete. Measures 24¹/₂" wide x 13" deep x 3¹/₄" high. Fastens to underside of laminate top with six #12 x 3/4" Phillips pan-head screws. Book basket is fully assembled to desk prior to shipment.

Cup Holder

Optional cup holder is made of 11-gauge steel and includes a 3" diameter cutout for drinks. Offered in Starlight Silver only. Cup holder is fully assembled to desk prior to shipment.

Testing

Ruckus lectern components originate from ISO 9000, ISO 9001 or ISO 9002 registered facilities. Ruckus lectern is designed and manufactured to meet or exceed required ANSI/BIFMA X5.5-2014 Desking.

DIMENSIONS

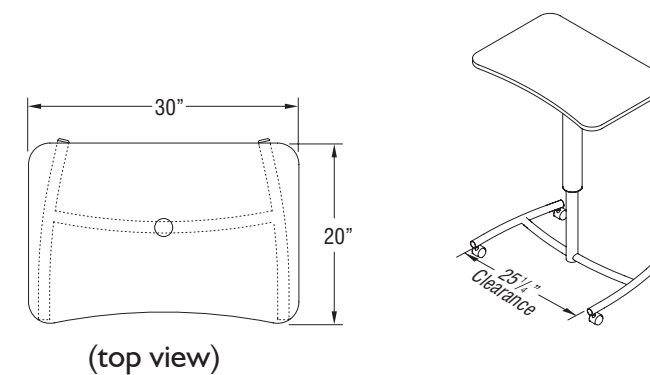
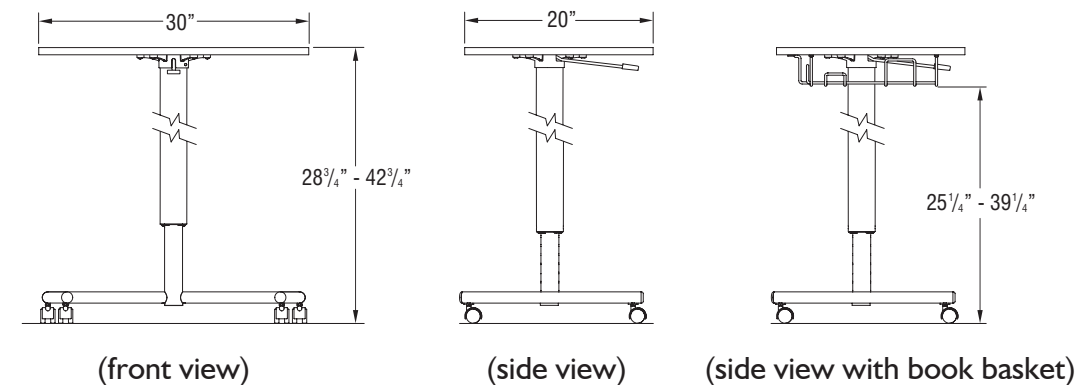



STATEMENT OF LINE

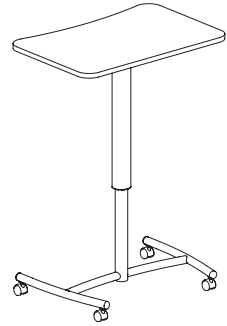

No Modesty Panel
RUW20

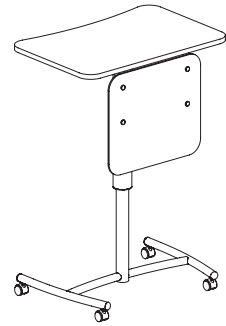

Acrylic Modesty Panel
RUX20

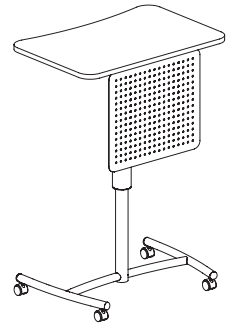

Perforated Steel Modesty Panel
RUX21

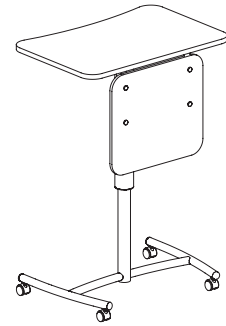

Polyester Felt Modesty Panel
RUX22



Base Color

Black	BL	Misty Brown	BRMY	Nemo
Blue Grey	GR	Nemo	BRNE	Nordic
Bronze Metallic	ZM	Nordic	BRND	Poppy Red
Cayenne	CY	Poppy Red	BRPR	Purple Haze
Champagne Metallic	CM	Purple Haze	BRPH	Rainforest
Chrome	CH	Rainforest	BRRQ	Raw Jasper
Cool Grey	CG	Raw Jasper	BRRJ	Rubber Ducky
Cottonwood	CO	Rubber Ducky	BRRK	Sand
Earthen Clay	CO	Sand	BRSB	Sky Blue
Espresso Metallic	EY	Sky Blue	BRSK	Starlight Silver Metallic
Everglade Shade	EX	Starlight Silver Metallic	BRSX	Surf's Up
Flannel	EV	Surf's Up	BRSP	Tarragon
Glitz Metallic	FN	Tarragon	BRTQ	Twilight Shadow
Hazy Jade	GZ	Twilight Shadow	BRTI	Ultra Blue
Honey Bee	HJ	Ultra Blue	BRUB	Warm Grey
Light Tone	HY	Warm Grey	BRWG	Zesty Lime
Mardi Gras	LG	Zesty Lime	BRZL	
Misty Brown	MG			
Nemo	MY			
Nordic	NE	*For height adjustable desks when chrome is selected the lower frame will be chrome and the upper column assembly will be Starlight Silver Metallic.		
Poppy Red	ND			
Purple Haze	PR			
Rainforest	PH	Acrylic Modesty Panel Color		
Raw Jasper	RQ	Colorless Acrylic	ACS	
Rubber Ducky	RJ	Cloud Acrylic	ACD	
Sand	RK	Laguna Acrylic	ALA	
Sky Blue	SA	Sunshine Acrylic	ASE	
Starlight Silver Metallic	SK	Tomato Acrylic	ATT	
Surf's Up	SX			
Tarragon	SP	Felt Modesty Panel Color		
Twilight Shadow	TQ	Dandelion felt color, Rubber Ducky bracket color	FTDD	
Ultra Blue	TI	Fawn felt color, Misty Brown bracket color	FTFW	
Warm Grey	UB	Flannel felt color, Flannel bracket color	FTFN	
Zesty Lime	WG	Heather felt color, Starlight Silver bracket color	FTHR	
	ZL	Lava felt color, Cayenne bracket color	FTLV	
		Mallard felt color, Everglade Shade bracket color	FTML	
		Midnight Blue felt color, Nordic bracket color	FTMB	
		Pepper felt color, Blue Grey bracket color	FTPR	
		Spring felt color, Zesty Lime bracket color	FTSG	
		Tidal Wave felt color, Twilight Shadow bracket color	FTTW	

*For height adjustable desks when chrome is selected the lower frame will be chrome and the upper column assembly will be Starlight Silver Metallic.

Book Basket Color

Black	BRBL	Black	SBL	Hazy Jade
Blue Grey	BRGR	Blue Grey	SGR	Italian Silver Ash
Bronze Metallic	BRZM	Bronze Metallic	SZM	Kensington Maple
Cayenne	BRCY	Cayenne	SCY	Light Tone
Champagne Metallic	BRCM	Champagne Metallic	SCM	Mardi Gras
Chrome	BRCH	Cool Grey	SCG	Misty Brown
Cool Grey	BRCG	Cottonwood	SCO	Monticello Maple
Cottonwood	BRCO	Earthen Clay	SEY	Multiplex
Earthen Clay	BREY	Espresso Metallic	XEX	Nemo
Espresso Metallic	BREX	Everglade Shade	SEV	Nordic
Everglade Shade	BREV	Flannel	SFN	Pinnacle Walnut
Flannel	BRFN	Glitz Metallic	SGZ	Poppy Red
Glitz Metallic	BRGZ	Hazy Jade	SHJ	Rainforest
Hazy Jade	BRHJ	Honey Bee	SHY	Raleigh Walnut
Honey Bee	BRHY	Light Tone	SLG	River Cherry
Light Tone	BRLG	Mardi Gras	SMG	Rubber Ducky
Mardi Gras	BRMG	Misty Brown	SMY	Sand

Finish Cards

View color swatches for items listed within this document.

<u>Paints</u>	<u>Wood/Veneer</u>	<u>Molded Edges</u>	<u>Hard Plastics</u>
<u>Plastics/Poly</u>	<u>Laminates</u>	<u>Edge Styles</u>	<u>Glass</u>

SNE	Sky Blue	ESK	Black Hills Oak	LBH
SND	Solano Walnut	ESG	Calcutta Marble	LCQ
SPR	Sterling Ash	EAZ	Dering Forest	LDF
SPH	Surf's Up	ESP	Fawn Cypress	LFQ
SRQ	Tarragon	ETQ	Ice Mist	LIM
SRJ	Twilight Shadow	ETI	Markerboard White	LMK
SRK	Ultra Blue	EUB	Valley Forge Elm	LVF
SSA	Valley Forge Elm	EVF	White River Forest	LWR
SSK	Warm Grey	EWG		
SSX	White River Forest	EWR		
SSP	Windsor Mahogany	EWY	*Additional colors may be available. Please contact KI customer service at 1-800-424-2432	
STQ	Zesty Lime	EZL		
STI				
SUB				
SWG	*Additional colors may be available. Please contact KI customer service at 1-800-424-2432			
SZL				

*Additional colors may be available. Please contact KI customer service at 1-800-424-2432

Surface Finish--Grade 1 Standard Laminate

EAK	Beigewood	LBZ
EAL	Belair	LBQ
EBZ	Beigewood	LBT
EBQ	Biltmore Cherry	LBK
EBT	Black	LBW
EBL	Brighton Walnut	LCO
EBH	Castle Oak	LCX
EGR	Cherry Storm	LCI
EBW	Classic Linen	LCC
ECO	Cocobala	LRI
ECY	Crisp Linen	LDR
ECX	Designer White	LDG
ECC	Dove Grey	LFC
ECG	Florence Walnut	LFH
ECJ	Friston Ash	LFW
EDF	Frosty White	LGN
EDR	Graphite Nebula	LGE
EEV	Grey	LHE
EEQ	High Rise	LHY
EFN	Hollyberry	LID
EFC	Island	LIT
EFH	Italian Silver Ash	LKM
EFW	Kensington Maple	LLB
EHW	Lapis Blue	LMT
EHJ	Monticello Maple	LNA
EIT	North Sea	LON
EKM	Ocean	LPW
ELG	Pinnacle Walnut	LRY
EMG	River Cherry	LSR
EMY	Shadow Zephyr	LAZ
EMT	Sterling Ash	LTV
EMB	Titanium Evolv	LWL
ENE	White Nebula	LWN
END	White Sand	LWY
EPW	Windsor Mahogany	
EPR		
ERQ	*Additional colors may be available. Please contact KI customer service at 1-800-424-2432	
ERW		
ERY	Surface Finish--Grade 2 Standard Laminate	
ERK	Akira	LAK
ESA	Black Alicante	LBY

*Additional colors may be available. Please contact KI customer service at 1-800-424-2432

Certain options referenced may not be available on GSA Schedule.



PRODUCT SPECIFICATIONS

Ruckus® Stacking Desks

October 2024

TECHNICAL SPECIFICATIONS

Desktops

All tops are $\frac{3}{4}$ " nominal overall thickness with .030" thick high-pressure laminate top surface and .028" phenolic backer (bottom surface). The density of the core in $\frac{3}{4}$ " thick tops is 45 lb/cu ft particleboard, M3 grade. All tops have a 2 mm bonded edge band for tamper and moisture resistance (73P). All desktops are available with either square or rounded corners.

Desk Frame

All desks have a welded steel frame consisting of two horizontal stringers and two horizontal crossbars made from $1\frac{1}{4}$ " 14-gauge square tubing, four vertical leg tubes made from $1\frac{1}{2}$ " O.D. 14-gauge round tubing, and six 14-gauge steel worksurface mounting brackets. The vertical legs of the desk frames are available in two variations, one for 29" fixed height desks and the other for 21-32" adjustable height desks.

Fixed-Height Legs

The vertical leg tubes of the fixed-height desk frames are roughly 26" in length and have pressed-in $\frac{5}{16}$ "-18 threaded tube inserts at the bottom for caster or glide attachment. Casters and glides are shipped assembled to the legs.

Screw Adjustable-Height Legs

The vertical leg tubes of the adjustable height desk frames are roughly 18" in length and are open at the bottom for inclusion of adjustable lower legs. The adjustable lower (inner) leg members are made from $1\frac{1}{4}$ " O.D. 14-gauge round tubing and are roughly 14" in length. The adjustable lower leg tubes include thirteen tapped mounting holes for twelve desk height options ranging from 21" to 32" in one inch increments, and attach to the upper (outer) leg tubes via two $\frac{1}{4}$ "-20 screws. At the bottom of the adjustable lower leg tubes are pressed-in $\frac{5}{16}$ "-18 threaded tube inserts for caster or glide attachment. Casters and glides are shipped assembled to the legs.

Casters & Glides

Each desk includes either: all casters, all glides, or a caster and glide mix that includes casters for two legs and glides for two legs. Casters are 50 mm O.D. double-wheel, molded nylon, black, unhooded, with brake and use a $\frac{5}{16}$ "-18 threaded steel stem for mounting. Glides are either: Black nylon with a $\frac{5}{16}$ "-18 threaded steel stem or Black nylon with felt base with a $\frac{5}{16}$ "-18 threaded steel stem. Glides are utilized with a glide locking spacer. The spacer has a steel $\frac{5}{16}$ "-18 threaded hole. The spacer and glide combination allows for interchangeability between glides and casters without a change in height of the desk surface.

Slide Strips

Each desk includes extruded polypropylene slide strips that are adhered to the underside of the desk frame stringers and front crossbars. The slide strips provide protection to the desktop surface and edge while the desks are stacked and unstacked.

DIMENSIONS

Ruckus Fixed-Height Stacking Desks

Model Number	A Overall Depth	B Overall Width	C Overall Height	D Desktop Depth	E Desktop Width	F Space Between Legs	G Space Between Legs	H Space Between Legs	I Bumper-to-Floor
RKEAA2030	23 $\frac{3}{4}$ "	29 $\frac{3}{4}$ "	29"	20"	29 $\frac{3}{4}$ "	24 $\frac{3}{4}$ "	12 $\frac{5}{8}$ "	20 $\frac{5}{8}$ "	26 $\frac{5}{8}$ "
RKEAA2036	23 $\frac{3}{4}$ "	35 $\frac{3}{4}$ "	29"	20"	35 $\frac{3}{4}$ "	30 $\frac{3}{4}$ "	12 $\frac{5}{8}$ "	20 $\frac{5}{8}$ "	26 $\frac{5}{8}$ "
RKEAA2430	27 $\frac{3}{4}$ "	29 $\frac{3}{4}$ "	29"	24"	29 $\frac{3}{4}$ "	24 $\frac{3}{4}$ "	16 $\frac{5}{8}$ "	24 $\frac{5}{8}$ "	26 $\frac{5}{8}$ "
RKEAA2436	27 $\frac{3}{4}$ "	35 $\frac{3}{4}$ "	29"	24"	35 $\frac{3}{4}$ "	30 $\frac{3}{4}$ "	16 $\frac{5}{8}$ "	24 $\frac{5}{8}$ "	26 $\frac{5}{8}$ "
RZEEA2030	23 $\frac{3}{4}$ "	29 $\frac{3}{4}$ "	29"	20"	29 $\frac{3}{4}$ "	24 $\frac{3}{4}$ "	12 $\frac{5}{8}$ "	20 $\frac{5}{8}$ "	26 $\frac{5}{8}$ "
RZEEA2036	23 $\frac{3}{4}$ "	35 $\frac{3}{4}$ "	29"	20"	35 $\frac{3}{4}$ "	30 $\frac{3}{4}$ "	12 $\frac{5}{8}$ "	20 $\frac{5}{8}$ "	26 $\frac{5}{8}$ "
RZEEA2430	27 $\frac{3}{4}$ "	29 $\frac{3}{4}$ "	29"	24"	29 $\frac{3}{4}$ "	24 $\frac{3}{4}$ "	16 $\frac{5}{8}$ "	24 $\frac{5}{8}$ "	26 $\frac{5}{8}$ "
RZEEA2436	27 $\frac{3}{4}$ "	35 $\frac{3}{4}$ "	29"	24"	35 $\frac{3}{4}$ "	30 $\frac{3}{4}$ "	16 $\frac{5}{8}$ "	24 $\frac{5}{8}$ "	26 $\frac{5}{8}$ "

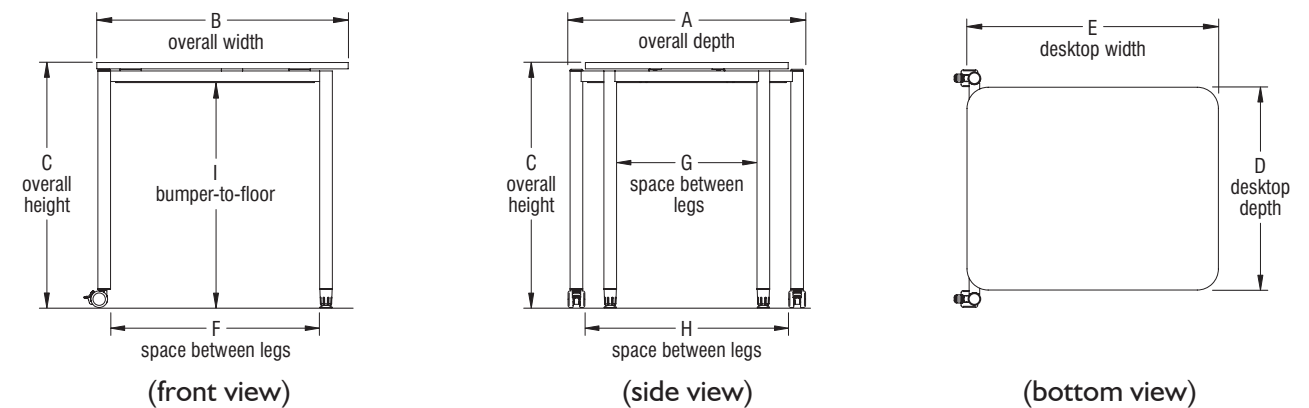

Ruckus Adjustable-Height Stacking Desks

Model Number	A Overall Depth	B Overall Width	C Overall Height	D Desktop Depth	E Desktop Width	F Space Between Legs	G Space Between Legs	H Space Between Legs	I Bumper-to-Floor
RKEEA2030	23 $\frac{3}{4}$ "	29 $\frac{3}{4}$ "	21"-32"	20"	29 $\frac{3}{4}$ "	24 $\frac{3}{4}$ "	12 $\frac{5}{8}$ "	20 $\frac{5}{8}$ "	18 $\frac{1}{16}$ "-29 $\frac{11}{16}$ "
RKEEA2036	23 $\frac{3}{4}$ "	35 $\frac{3}{4}$ "	21"-32"	20"	35 $\frac{3}{4}$ "	30 $\frac{3}{4}$ "	12 $\frac{5}{8}$ "	20 $\frac{5}{8}$ "	18 $\frac{1}{16}$ "-29 $\frac{11}{16}$ "
RKEEA2430	27 $\frac{3}{4}$ "	29 $\frac{3}{4}$ "	21"-32"	24"	29 $\frac{3}{4}$ "	24 $\frac{3}{4}$ "	16 $\frac{5}{8}$ "	24 $\frac{5}{8}$ "	18 $\frac{1}{16}$ "-29 $\frac{11}{16}$ "
RKEEA2436	27 $\frac{3}{4}$ "	35 $\frac{3}{4}$ "	21"-32"	24"	35 $\frac{3}{4}$ "	30 $\frac{3}{4}$ "	16 $\frac{5}{8}$ "	24 $\frac{5}{8}$ "	18 $\frac{1}{16}$ "-29 $\frac{11}{16}$ "
RZEEA2030	23 $\frac{3}{4}$ "	29 $\frac{3}{4}$ "	21"-32"	20"	29 $\frac{3}{4}$ "	24 $\frac{3}{4}$ "	12 $\frac{5}{8}$ "	20 $\frac{5}{8}$ "	18 $\frac{1}{16}$ "-29 $\frac{11}{16}$ "
RZEEA2036	23 $\frac{3}{4}$ "	35 $\frac{3}{4}$ "	21"-32"	20"	35 $\frac{3}{4}$ "	30 $\frac{3}{4}$ "	12 $\frac{5}{8}$ "	20 $\frac{5}{8}$ "	18 $\frac{1}{16}$ "-29 $\frac{11}{16}$ "
RZEEA2430	27 $\frac{3}{4}$ "	29 $\frac{3}{4}$ "	21"-32"	24"	29 $\frac{3}{4}$ "	24 $\frac{3}{4}$ "	16 $\frac{5}{8}$ "	24 $\frac{5}{8}$ "	18 $\frac{1}{16}$ "-29 $\frac{11}{16}$ "
RZEEA2436	27 $\frac{3}{4}$ "	35 $\frac{3}{4}$ "	21"-32"	24"	35 $\frac{3}{4}$ "	30 $\frac{3}{4}$ "	16 $\frac{5}{8}$ "	24 $\frac{5}{8}$ "	18 $\frac{1}{16}$ "-29 $\frac{11}{16}$ "

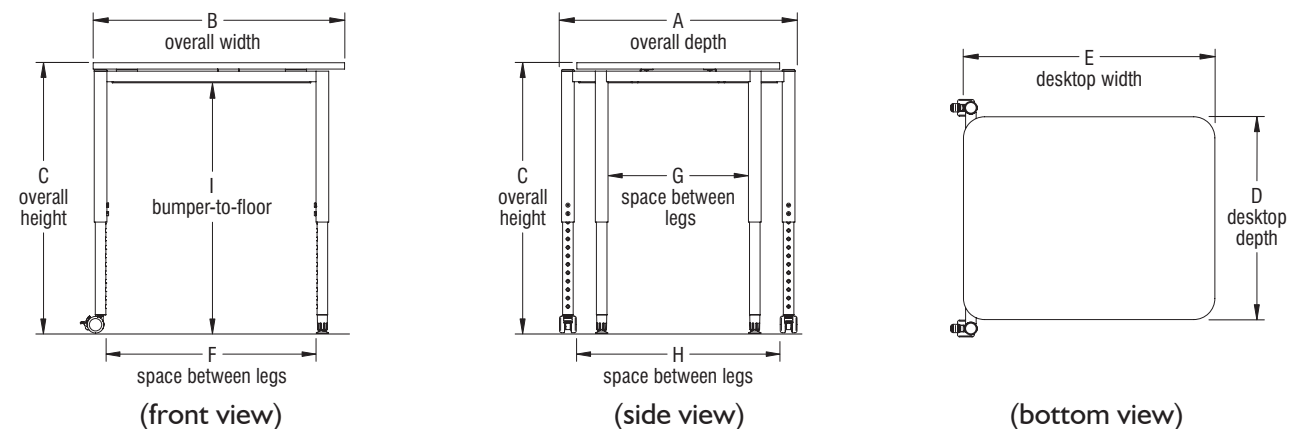



DIMENSIONS

Ruckus Stacking Desks Footprint Calculations

Ruckus stacking desks have a maximum stacking quantity of four desks.

Stacking Height Footprint Calculation: Overall height of stacked desks = 29" for the first desk, plus 2³/₈" for each additional stacked desk.

Examples: 2 desks: $29" + (2\frac{3}{8}" \times 1) = 31\frac{3}{8}"$
 4 desks: $29" + (2\frac{3}{8}" \times 3) = 36\frac{1}{8}"$

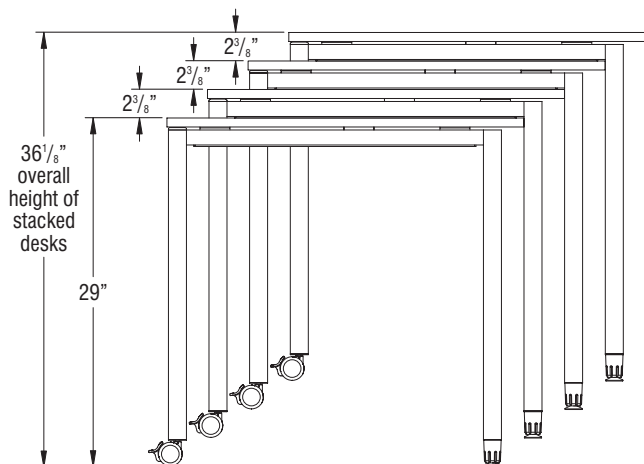

Stacking Desk Height Footprint Examples

Number of Desks	Overall Height of Desks
1	29"
2	31 ³ / ₈ "
3	33 ³ / ₄ "
4	36 ¹ / ₈ "

Stacking Width Footprint Calculation: Overall width of stacked desks = 29³/₄" or 35³/₄" for the first desk (depending on the width of the unit), plus 3³/₈" for each additional stacked desk.

Examples: 2 desks (30" W): $29\frac{3}{4}" + (3\frac{3}{8}" \times 1) = 33\frac{1}{8}"$
 4 desks (36" W): $35\frac{3}{4}" + (3\frac{3}{8}" \times 3) = 45\frac{7}{8}"$

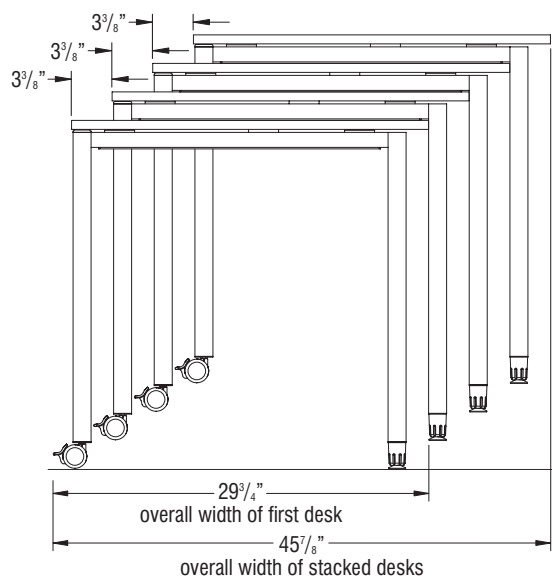

30" Wide Stacking Desk Width Footprint Examples

Number of Desks	Overall Width of Desks
1	29 ³ / ₄ "
2	33 ¹ / ₈ "
3	36 ¹ / ₂ "
4	39 ⁷ / ₈ "

36" Wide Stacking Desk Width Footprint Examples

Number of Desks	Overall Width of Desks
1	35 ³ / ₄ "
2	39 ¹ / ₈ "
3	42 ¹ / ₂ "
4	45 ⁷ / ₈ "

STATEMENT OF LINE

Ruckus Fixed-Height Stacking Desks

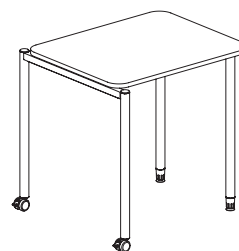

Rounded Corners

RKEAA2030
 RKEAA2036
 RKEAA2430
 RKEAA2436

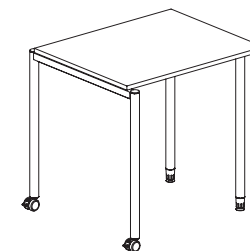

Square Corners

RZEEA2030
 RZEEA2036
 RZEEA2430
 RZEEA2436

Ruckus Adjustable-Height Stacking Desks

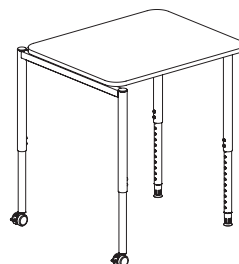

Rounded Corners

RKEEA2030
 RKEEA2036
 RKEEA2430
 RKEEA2436

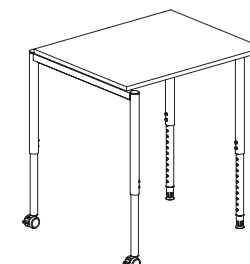

Square Corners

RZEEA2030
 RZEEA2036
 RZEEA2430
 RZEEA2436

**Surface Finish--Grade 1 Standard Laminate**

Beigewood	LBZ	Frosty White	EFW
Belair	LBQ	Hartley Walnut	EHW
Biltmore Cherry	LBT	Hazy Jade	EHJ
Black	LBK	Italian Silver Ash	EIT
Brighton Walnut	LBW	Kensington Maple	EKM
Castle Oak	LCO	Light Tone	ELG
Cherry Storm	LCX	Mardi Gras	EMG
Classic Linen	LCI	Misty Brown	EMY
Cocobala	LCC	Monticello Maple	EMT
Crisp Linen	LRI	Multiplex	EMB
Designer White	LDR	Nemo	ENE
Dove Grey	LDG	Nordic	END
Florence Walnut	LFC	Pinnacle Walnut	EPW
Friston Ash	LFH	Poppy Red	EPR
Frosty White	LFW	Rainforest	ERQ
Graphite Nebula	LGN	Raleigh Walnut	ERW
Grey	LGE	River Cherry	ERY
High Rise	LHE	Rubber Ducky	ERK
Hollyberry	LHY	Sand	ESA
Island	LID	Sky Blue	ESK
Italian Silver Ash	LIT	Solano Walnut	ESG
Kensington Maple	LKM	Sterling Ash	EAZ
Lapis Blue	LLB	Surf's Up	ESP
Monticello Maple	LMT	Tarragon	ETQ
North Sea	LNA	Twilight Shadow	ETI
Ocean	LON	Ultra Blue	EUB
Pinnacle Walnut	LPW	Valley Forge Elm	EVF
River Cherry	LRY	Warm Grey	EWG
Shadow Zephyr	LSR	White River Forest	EWR
Sterling Ash	LAZ	Windsor Mahogany	EWY
Titanium Evolv	LTV	Zesty Lime	EZL
White Nebula	LWL		
White Sand	LWN	*Additional colors may be available. Please contact KI customer service at 1-800-424-2432	
Windsor Mahogany	LWY		

Base Finish**Edge Color for 73P Edge**

Akira	EAK	Casters/felt glides	BCF
Beigewood	EBZ	Casters/nylon glides	BCN
Belair	EBQ	Casters	CCC
Biltmore Cherry	EBT	Felt glides	GFT
Black	EBL	Nylon glides	GNV
Black Hills Oak	EBH		
Blue Grey	EGR		
Brighton Walnut	EBW		
Castle Oak	ECO		
Cayenne	ECY		
Cherry Storm	ECX		
Cocobala	ECC		
Cool Grey	ECG		
Cumberland Walnut	ECJ		
Dering Forest	EDF		
Designer White	EDR		
Everglade Shade	EEV		
Fawn Cypress	EFQ		
Flannel	EFN		
Florence Walnut	EFC		
Friston Ash	EFH		

Finish Cards

View color swatches for items listed within this document.

Paints**Wood/Veneer****Molded Edges****Hard Plastics****Plastics/Poly****Laminates****Edge Styles****Glass**

Certain options referenced may not be available on GSA Schedule.



PRODUCT SPECIFICATIONS ■

Ruckus Post-Leg Desks & Activity Tables

February 2026

TECHNICAL SPECIFICATIONS

Post-Leg Desktops & Activity Tabletops

All tops are 1 1/4" or 3/4" nominal overall thickness with .030" thick high-pressure laminate top surface and .028" phenolic backer (bottom surface). All post-leg desks and kite and diamond activity tables are available with either top thickness. All remaining activity tables are only available with the 1 1/4" top thickness. The density of the core in standard tops is 45 lb/cu ft particleboard, M3 grade. All tops have a 2 mm bonded edge band for tamper and moisture resistance, specified as 74P for 1 1/4" tops and as 73P for 3/4" tops.

Post Leg Assembly

Leg assembly heights are achieved by accounting for 1 1/4" tabletop thickness. For tables or desks with 3/4" tops, height dimensions are 1/2" (nominal) less. Leg assemblies come in four variations, 29" fixed-height, 12-19" floor adjustable-height, 20-33" sit adjustable-height, & 29-42" sit-stand adjustable-height. All adjustable-height table legs adjust with screws in 1" increments.

Fixed-Height Post Leg Construction

Consists of a 1 3/4" O.D. 14-gauge steel tube welded to a 1/4" thick mounting plate. Leg bottom has a pressed-in steel insert with 5/16-18 UNC threaded hole for either caster or glide.

Screw Adjustable-Height Post Leg Construction (upper & lower leg members)

The upper (outer), leg member consists of a 1 3/4" O.D. 14-gauge steel tube welded to a 1/4" thick mounting plate. The lower (inner) leg member consists of a 1 1/2" O.D. 14-gauge steel tube containing fifteen 1/4-20 UNC holes in 1" increments to allow for error-free desk and table height adjustment, and has a pressed-in plastic insert at floor level with 5/16-18 UNC steel threaded hole for either caster or glide. Height adjustment of each leg assembly is locked using two 1/4-20 screws with lock washers at the outer leg member, threading into the inner leg member. Post-leg desks & kite or diamond activity tables use a 1/4" thick triangular mounting plate (5 x 6 1/2"). All other tables use a 1/4" thick square mounting plate (8" x 8"). Casters and glides are shipped assembled to the legs. Adjustable legs with a height range of 12-19" are shipped from the factory pre-set to 19" table height. Adjustable legs with a height range of 20-42" are shipped from the factory pre-set to 29" table height.

Castors & Glides

Each table includes either: all casters, all glides, or a caster and glide mix that includes casters for two legs and glides for all remaining legs. 12-19" post-leg assemblies are available with glides only and do not include spacers. Casters are 50 mm O.D. double-wheel, molded nylon, black, unhooded, with brake and use a 5/16-18 threaded steel stem for mounting. Glides are either: Black nylon with a 5/16-18 threaded steel stem or Black nylon with felt base with a 5/16-18 threaded steel stem. Glides are utilized with a Black nylon glide locking spacer (patent pending). The spacer has steel 5/16-18 threaded hole. The spacer and glide combination allows for interchangeability between glides and casters without a change in height of the desk or table surface.

TECHNICAL SPECIFICATIONS

Undersurface Accessories

Book Basket

Optional book basket is made of chrome plated 7 mm diameter solid steel wire. Fastens to underside of top with eight #12 x 3/4" Phillips pan head screws. Book basket is only available on the Ruckus Post-Leg Desk.

Small & Large Polypropylene Book Boxes (under desk)

Optional solid molded thermoplastic polypropylene book box. Translucent finish helps provide safe environment while allowing for some degree of personal privacy. Molded-in pencil tray keeps items conveniently inside book box within easy reach, not on the floor or in the back of the book box. Fastens to underside of top with nine #12 x 3/4" Phillips pan head screws. Small and large poly book boxes are only available on Ruckus Post-Leg Desks.

Small & Large Steel Book Boxes (under desk)

Optional formed sheet steel book box is constructed of 16-gauge cold-rolled steel (C.R.S) and features a powder-coat painted finish in select KI colors. Fastens to underside of top with six #12 x 3/4" Phillips pan head screws. Small and large steel book boxes are only available on Ruckus Post-Leg Desks.

Removable Tote Storage

Totes are molded from talc-filled polypropylene containing an anti-static additive, which adds strength, rigidity and reduces the attraction of dust. Totes are completely translucent for visibility of the contents within them, and they are compatible with most cleaners used in schools. Durable translucent polycarbonate rails are mounted to the underside of the worksurface for the totes to slide intuitively in and out. Rails contain a gravity-activated "stop" feature to prevent accidental tote drops and messes. Removable tote storage is available on both the Ruckus Post-Leg Desks and select Activity Tables.

Book Bag Hook

Optional book bag hook is formed from 1/4" solid wire rod and is chrome plated for long lasting wear resistance. Fastens to underside of top with two #12 x 3/4" Phillips pan head screws. Hook can be combined with any of the under storage options. Book bag hook must be ordered separately as an accessory.



DIMENSIONS

Ruckus Post-Leg Rectangular Desk

Model Number	A Desk Depth	B Desk Width	C Desk Height	D Space Between Legs	E Space Between Legs	Worksurface Thickness	Fixed Legs	Adjustable Legs	Large Book Box
RDEHA2030-73P	20"	29.75"	11 1/2" - 18 1/2"	23.25"	13.25"	3/4"		•	
RDEHA2036-73P	20"	35.75"	11 1/2" - 18 1/2"	29"	13.25"	3/4"		•	•
RDEHA2436-73P	24"	35.75"	11 1/2" - 18 1/2"	29"	17.25"	3/4"		•	•
RDEAA2030	20"	29.75"	29"	23.25"	13.25"	3/4" or 1 1/4"	•		
RDEAA2036	20"	35.75"	29"	29"	13.25"	3/4" or 1 1/4"	•		•
RDEAA2436	24"	35.75"	29"	29"	17.25"	3/4" or 1 1/4"	•		•
RDEEA2030	20"	29.75"	20" - 33"	23.25"	13.25"	3/4" or 1 1/4"		•	
RDEEA2036	20"	35.75"	20" - 33"	29"	13.25"	3/4" or 1 1/4"		•	•
RDEEA2037ADA	20"	37"	20" - 33"	30.25"	13.25"	3/4" or 1 1/4"		•	•
RDEEA2436	24"	35.75"	20" - 33"	29"	17.25"	3/4" or 1 1/4"		•	•
RDEFA2030	20"	29.75"	29" - 42"	23.25"	13.25"	3/4" or 1 1/4"		•	
RDEFA2036	20"	35.75"	29" - 42"	29"	13.25"	3/4" or 1 1/4"		•	•
RDEFA2037ADA	20"	37"	29" - 42"	30.25"	13.25"	3/4" or 1 1/4"		•	•
RDEFA2436	24"	35.75"	29" - 42"	29"	17.25"	3/4" or 1 1/4"		•	•

(model RDEEA2436 with caster/glide base shown)

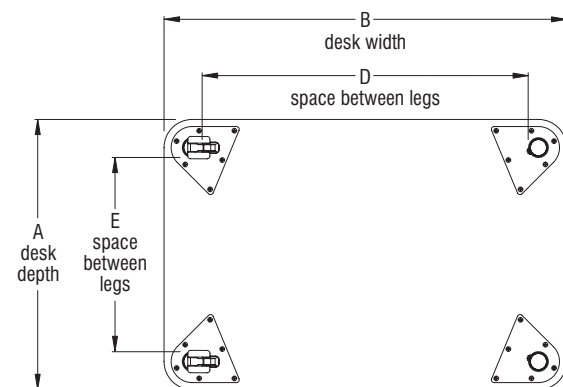

(bottom view)

Note: Desk height dimensions in the chart above (excluding RDEHA models) represent desks with a nominal worksurface thickness of 1 1/4". If the worksurface thickness is 3/4", 1/2" must be subtracted from the "desk height" column in the chart. Reference the "Desk/Table Storage Dimensions" charts on pages 9-12 for storage clearance dimensions.

Note: For Ruckus Post-Leg Rectangular Desk models RDEAA2030, RDEEA2030, RDEFA2030 and RDEHA2030 the entire Ruckus chair frame will not fit between the legs, and therefore will not stack on the desk surface.

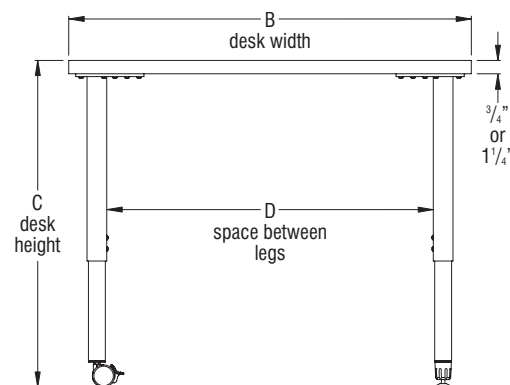

(front view)

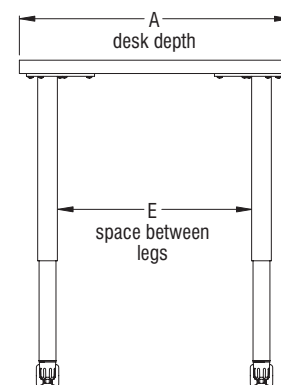

(side view)

DIMENSIONS

Ruckus Post-Leg E-Triangle Desk

Model Number	A Desk Depth	B Desk Width	C Desk Height	D Space Between Legs	E Knee Clearance	Worksurface Thickness	Fixed Legs	Adjustable Legs	Large Book Box
RDEHK32-73P	28.38"	32"	11 1/2" - 18 1/2"	25.38"	25.01"	3/4"		•	•
RDEHK37-73P	32.71"	37"	11 1/2" - 18 1/2"	30.38"	29.34"	3/4"		•	•
RDEAK32	28.38"	32"	29"	25.38"	25.01"	3/4" or 1 1/4"	•		
RDEAK37	32.71"	37"	29"	30.38"	29.34"	3/4" or 1 1/4"	•		•
RDEEK32	28.38"	32"	20" - 33"	25.38"	25.01"	3/4" or 1 1/4"		•	
RDEEK37	32.71"	37"	20" - 33"	30.38"	29.34"	3/4" or 1 1/4"		•	•
RDEFK32	28.38"	32"	29" - 42"	25.38"	25.01"	3/4" or 1 1/4"		•	
RDEFK37	32.71"	37"	29" - 42"	30.38"	29.34"	3/4" or 1 1/4"		•	•

(model RDEEK32 with caster/glide base shown)

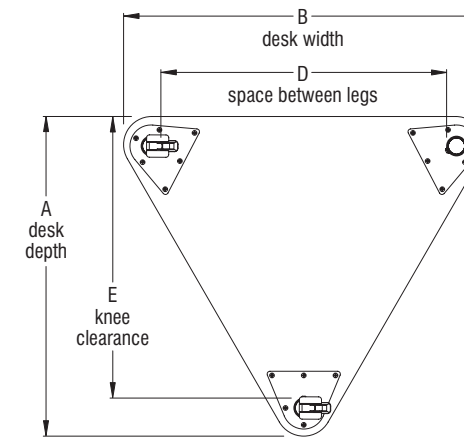

(bottom view)

Note: Desk height dimensions in the chart above (excluding RDEHK models) represent desks with a nominal worksurface thickness of 1 1/4". If the worksurface thickness is 3/4", 1/2" must be subtracted from the "desk height" column in the chart. Reference the "Desk/Table Storage Dimensions" charts on pages 9-12 for storage clearance dimensions.

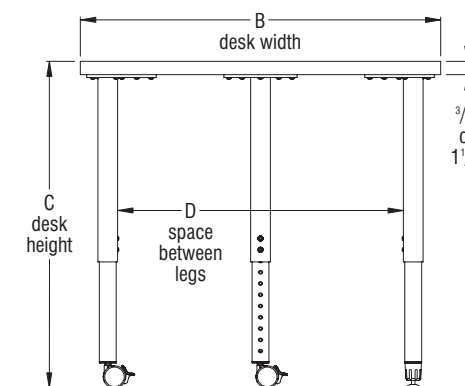

(front view)

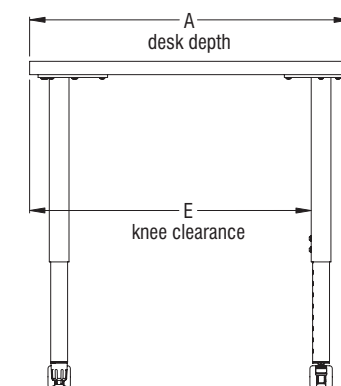

(side view)



DIMENSIONS

Ruckus Post-Leg R-Triangle Desk

Model Number	A Desk Depth	B Desk Width	C Desk Height	D Space Between Legs	E Knee Clearance	F	G Space Between Legs	Worksurface Thickness	Fixed Legs	Adjustable Legs	Large Book Box
RDEAL39	21.79"	38.59"	29"	31.84"	18.42"	28.75"	22"	3/4" or 1 1/4"	•		
RDEAL47	25.75"	46.49"	29"	39.75"	22.37"	34.34"	27.59"	3/4" or 1 1/4"	•		•
RDEEL39	21.79"	38.59"	20" - 33"	31.84"	18.42"	28.75"	22"	3/4" or 1 1/4"		•	
RDEEL47	25.75"	46.49"	20" - 33"	39.75"	22.37"	34.34"	27.59"	3/4" or 1 1/4"		•	•
RDEFL39	21.79"	38.59"	29" - 42"	31.84"	18.42"	28.75"	22"	3/4" or 1 1/4"		•	
RDEFL47	25.75"	46.49"	29" - 42"	39.75"	22.37"	34.34"	27.59"	3/4" or 1 1/4"		•	•

(model RDEEL39 with caster/glide base shown)

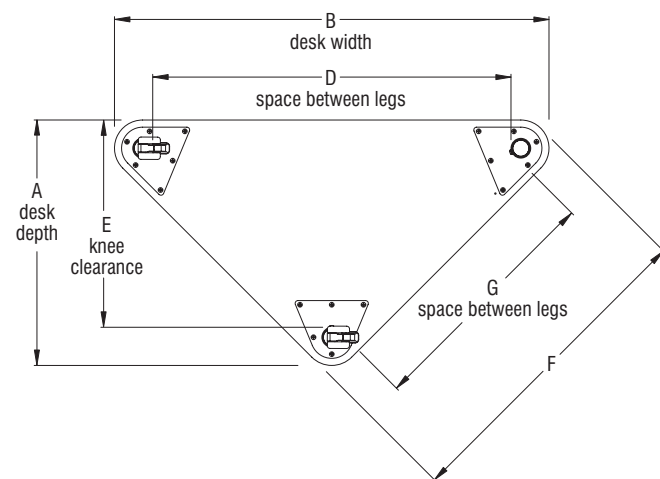

(bottom view)

Note: Desk height dimensions in the chart above represent desks with a nominal worksurface thickness of 1 1/4". If the worksurface thickness is 3/4", 1/2" must be subtracted from the "desk height" column in the chart. Reference the "Desk/Table Storage Dimensions" charts on pages 9-12 for storage clearance dimensions.

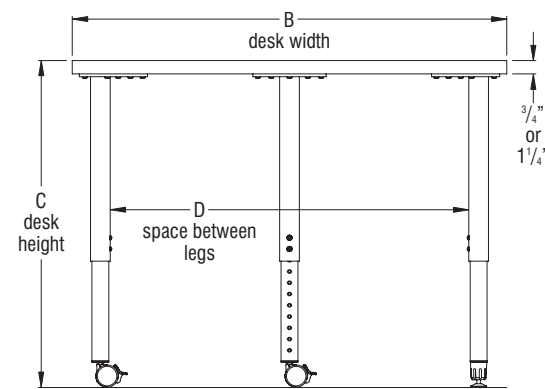

(front view)

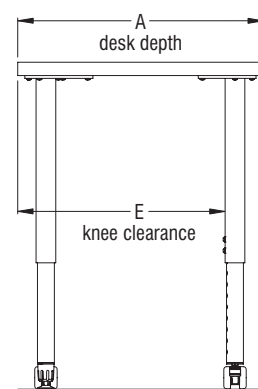

(side view)

DIMENSIONS

Ruckus Post-Leg Trapezoid Desk

Model Number	A Desk Depth	B Desk Width	C Desk Height	D Space Between Legs	E Space Between Legs	F Space Between Legs	G Knee Clearance	Worksurface Thickness	Fixed Legs	Adjustable Legs	Large Book Box
RDEAM34	21"	34"	29"	27.38"	14.19"	8.78"	17.69"	3/4" or 1 1/4"	•		
RDEAM37	23.50"	37"	29"	30.38"	14.68"	8.88"	20.19"	3/4" or 1 1/4"	•		•
RDEEM34	21"	34"	20" - 33"	27.38"	14.19"	8.78"	17.69"	3/4" or 1 1/4"		•	
RDEEM37	23.50"	37"	20" - 33"	30.38"	14.68"	8.88"	20.19"	3/4" or 1 1/4"		•	•
RDEFM34	21"	34"	29" - 42"	27.38"	14.19"	8.78"	17.69"	3/4" or 1 1/4"		•	
RDEFM37	23.50"	37"	29" - 42"	30.38"	14.68"	8.88"	20.19"	3/4" or 1 1/4"		•	•

(model RDEEM34 with caster/glide base shown)

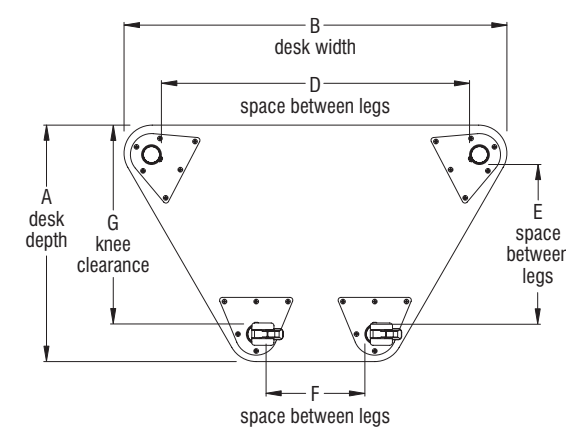

(bottom view)

Note: Desk height dimensions in the chart above represent desks with a nominal worksurface thickness of 1 1/4". If the worksurface thickness is 3/4", 1/2" must be subtracted from the "desk height" column in the chart. Reference the "Desk/Table Storage Dimensions" charts on pages 9-12 for storage clearance dimensions.

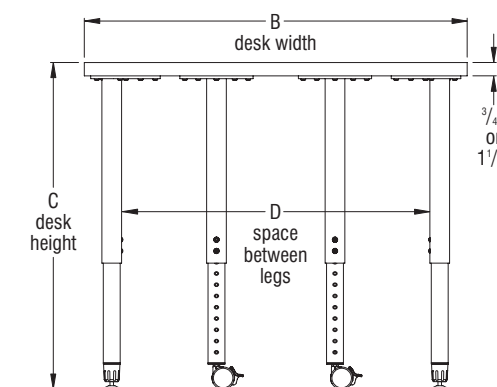

(front view)

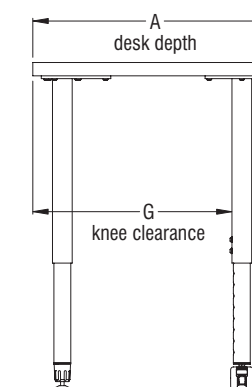

(side view)



DIMENSIONS

Ruckus Post-Leg Oddquad Desk

Model Number	A Desk Depth	B Desk Width	C Desk Height	D Space Between Legs	E Knee Clearance	F Space Between Legs	G Space Between Legs	Worksurface Thickness	Fixed Legs	Adjustable Legs	Large Book Box
RDEAZ36	22.11"	35.44"	29"	28.69"	18.74"	18.85"	15.36"	3/4" or 1 1/4"	•		
RDEAZ39	23.98"	38.56"	29"	31.81"	20.61"	21.32"	18.98"	3/4" or 1 1/4"	•		•
RDEEZ36	22.11"	35.44"	20" - 33"	28.69"	18.74"	18.85"	15.36"	3/4" or 1 1/4"		•	
RDEEZ39	23.98"	38.56"	20" - 33"	31.81"	20.61"	21.32"	18.98"	3/4" or 1 1/4"		•	•
RDEFZ36	22.11"	35.44"	29" - 42"	28.69"	18.74"	18.85"	15.36"	3/4" or 1 1/4"		•	
RDEFZ39	23.98"	38.56"	29" - 42"	31.81"	20.61"	21.32"	18.98"	3/4" or 1 1/4"		•	•

(model RDEEZ36 with caster/glide base shown)

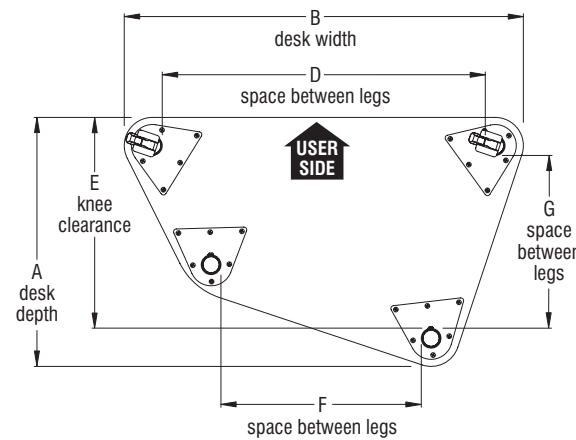

(bottom view)

Note: Desk height dimensions in the chart above represent desks with a nominal worksurface thickness of 1 1/4". If the worksurface thickness is 3/4", 1/2" must be subtracted from the "desk height" column in the chart. Reference the "Desk/Table Storage Dimensions" charts on pages 9-12 for storage clearance dimensions.

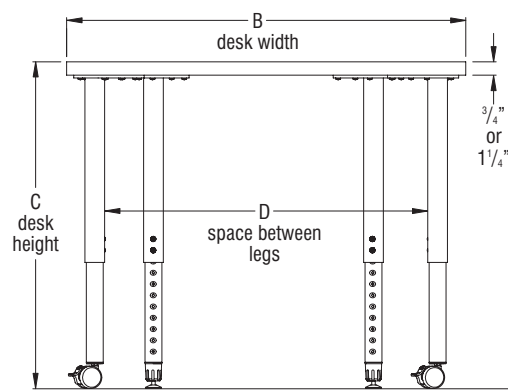

(front view)

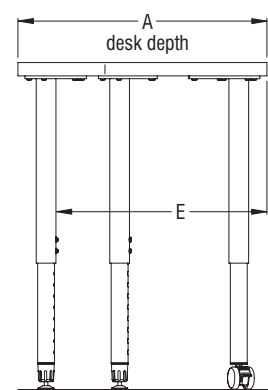

(side view)

DIMENSIONS

Ruckus Post-Leg Pentaquad Desk

Model Number	A Desk Depth	B Desk Width	C Desk Height	D Space Between Legs	E Knee Clearance	F Space Between Legs	G Space Between Legs	Worksurface Thickness	Fixed Legs	Adjustable Legs	Removable Tote Storage
RDEAS2630	30"	26"	29"	23"	22.54"	19"	11"	3/4" or 1 1/4"	•		I
RDEES2630	30"	26"	20" - 33"	23"	22.54"	19"	11"	3/4" or 1 1/4"		•	I
RDEFS2630	30"	26"	29" - 42"	23"	22.54"	19"	11"	3/4" or 1 1/4"		•	I

(model RDEES2630 with caster/glide base shown)

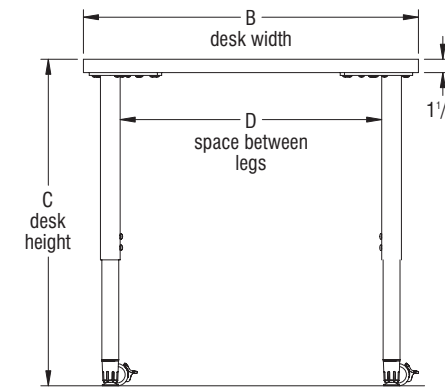

(front view)

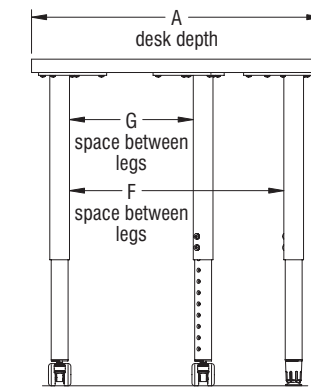

(side view)

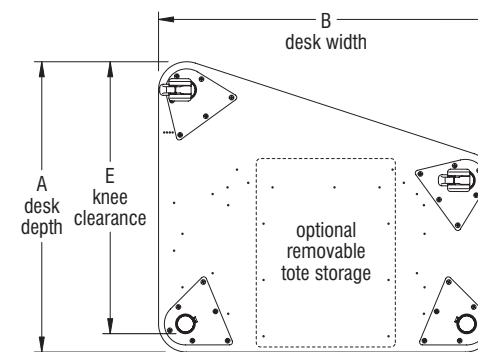

(bottom view)

Note: Desk height dimensions in the chart above represent desks with a nominal worksurface thickness of 1 1/4". If the worksurface thickness is 3/4", 1/2" must be subtracted from the "desk height" column in the chart. Reference the "Desk/Table Storage Dimensions" charts on pages 9-12 for storage clearance dimensions.



DIMENSIONS - Desk/Table Storage Dimensions

Book Basket

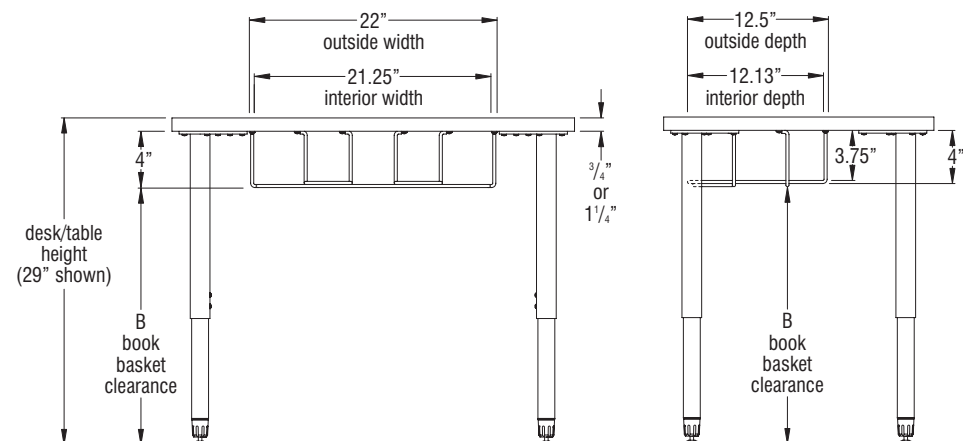

	Book Basket
Model Number	46.9351
Outside Width	22"
Outside Depth	12.5"
Outside Height	4"
Interior Width	21.25"
Interior Depth	12.13"
Interior Height	3.75"

Reference the "Desk/Table Storage Clearance" chart on page 12 for storage clearance dimensions.

DIMENSIONS - Desk/Table Storage Dimensions

Small Steel Book Box

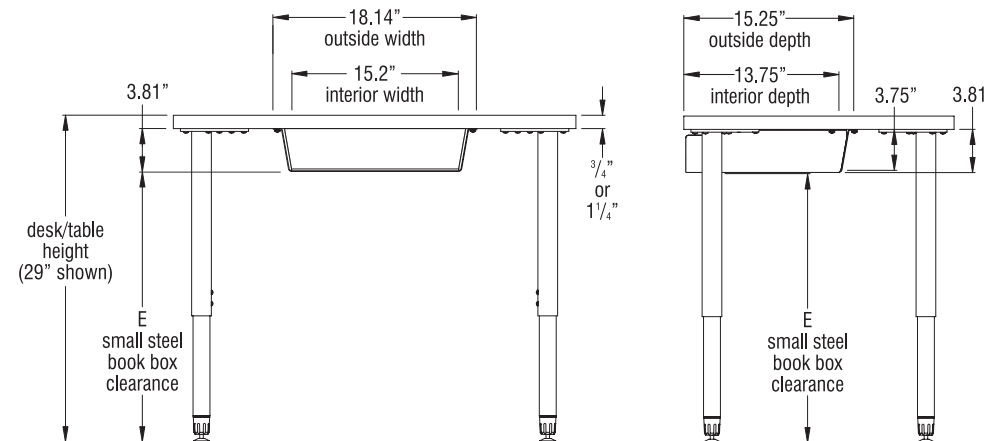

	Small Steel Book Box
Model Number	46.8292
Outside Width	18.14"
Outside Depth	15.25"
Outside Height	3.81"
Interior Width	15.2"
Interior Depth	13.75"
Interior Height	3.75"

Reference the "Desk/Table Storage Clearance" chart on page 12 for storage clearance dimensions.

Small Polypropylene Book Box

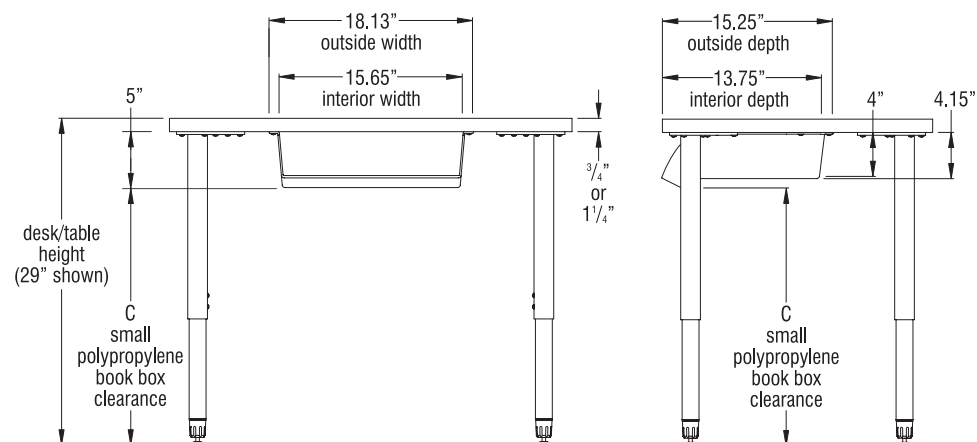

	Small Polypropylene Book Box
Model Number	46.6232
Outside Width	18.13"
Outside Depth	15.25"
Outside Height	5"
Interior Width	15.65"
Interior Depth	13.75"
Interior Height	4"

Reference the "Desk/Table Storage Clearance" chart on page 12 for storage clearance dimensions.

Large Steel Book Box

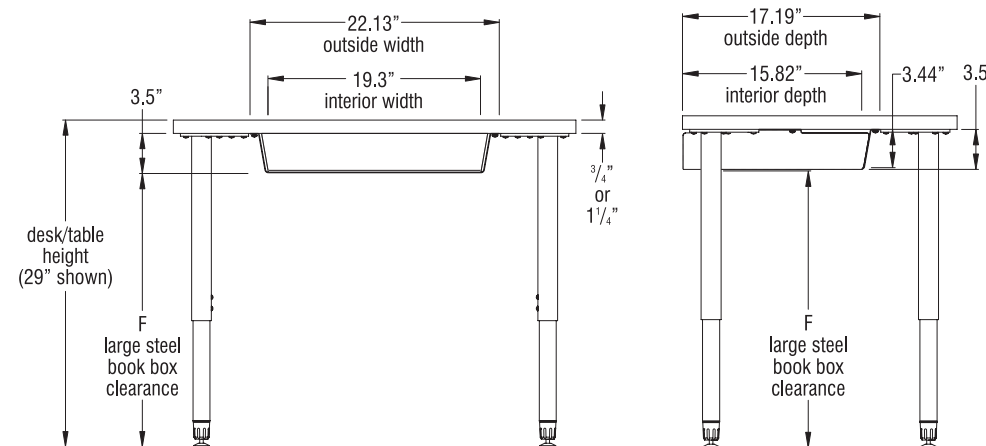

	Large Steel Book Box
Model Number	46.8291
Outside Width	22.13"
Outside Depth	17.19"
Outside Height	3.5"
Interior Width	19.3"
Interior Depth	15.82"
Interior Height	3.44"

Reference the "Desk/Table Storage Clearance" chart on page 12 for storage clearance dimensions.

Large Polypropylene Book Box

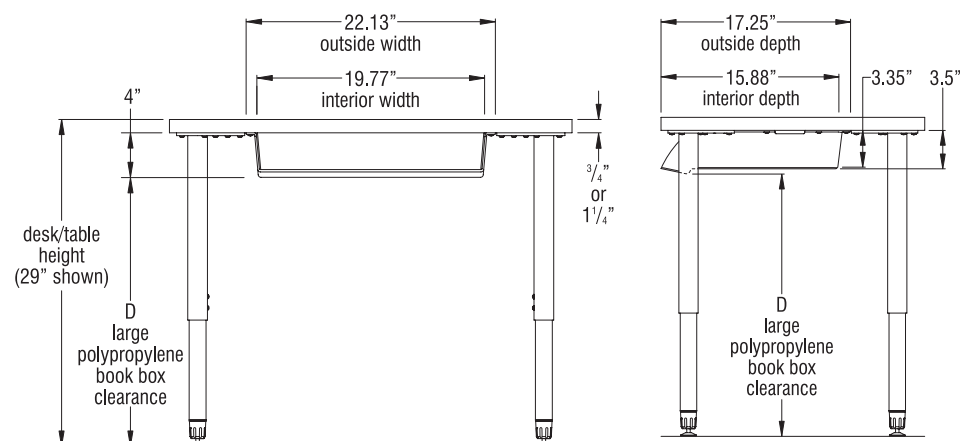

	Large Polypropylene Book Box
Model Number	46.9359
Outside Width	22.13"
Outside Depth	17.25"
Outside Height	4"
Interior Width	19.77"
Interior Depth	15.88"
Interior Height	3.35"

Reference the "Desk/Table Storage Clearance" chart on page 12 for storage clearance dimensions.



DIMENSIONS - Desk/Table Storage Dimensions

Tote

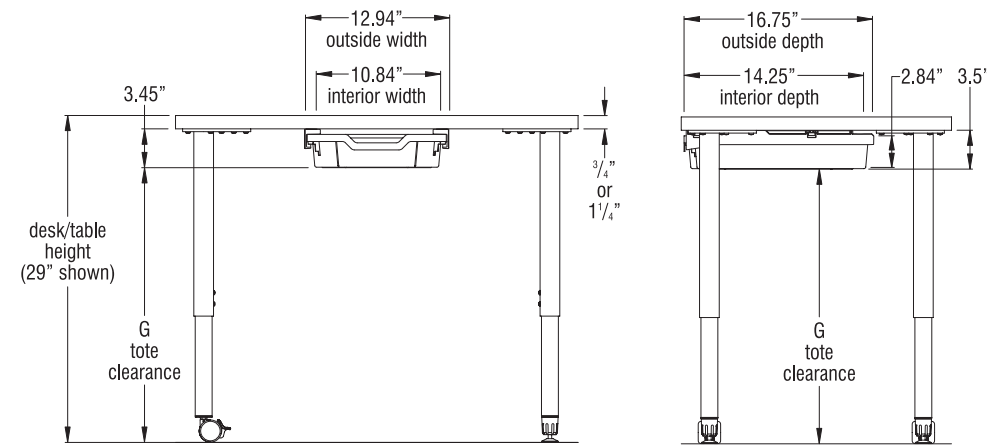

	3" Tote with Rails
Model Number	RKAUSRTKIT1
Outside Width	12.94"
Outside Depth	16.75"
Outside Height	3.5"
Interior Width	10.84"
Interior Depth	14.25"
Interior Height	2.84"

Reference the "Desk/Table Storage Clearance" chart on page 12 for storage clearance dimensions.

Ruckus Activity Table (with no storage unit)

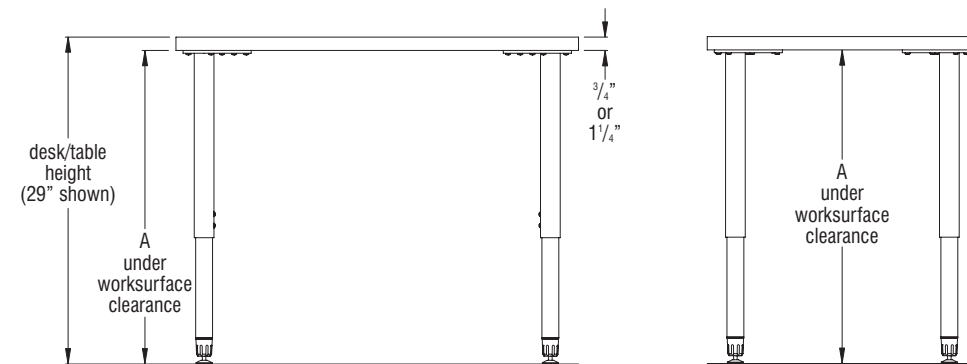

Reference the "Desk/Table Storage Clearance" chart on page 12 for storage clearance dimensions.

DIMENSIONS - Desk/Table Storage Dimensions

Desk/Table Storage Clearance

Desk/ Table Height Range	A No Desk/Table Storage Under Worksurface Clearance	B Book Basket Clearance	C Small Polypropylene Book Box Clearance	D Large Polypropylene Book Box Clearance	E Small Steel Book Box Clearance	F Large Steel Book Box Clearance	G Tote Clearance
12"	10.82"	5.82"	5.87"	6.86"	7.01"	7.32"	7.37"
13"	11.82"	6.82"	6.87"	7.86"	8.01"	8.32"	8.37"
14"	12.82"	7.82"	7.87"	8.86"	9.01"	9.32"	9.37"
15"	13.82"	8.82"	8.87"	9.86"	10.01"	10.32"	10.37"
16"	14.82"	9.82"	9.87"	10.86"	11.01"	11.32"	11.37"
17"	15.82"	10.82"	10.87"	11.86"	12.01"	12.32"	12.37"
18"	16.82"	11.82"	11.87"	12.86"	13.01"	13.32"	13.37"
19"	17.82"	12.82"	12.87"	13.86"	14.01"	14.32"	14.37"
20"	18.82"	13.82"	13.87"	14.86"	15.01"	15.32"	15.37"
21"	19.82"	14.82"	14.87"	15.86"	16.01"	16.32"	16.37"
22"	20.82"	15.82"	15.87"	16.86"	17.01"	17.32"	17.37"
23"	21.82"	16.82"	16.87"	17.86"	18.01"	18.32"	18.37"
24"	22.82"	17.82"	17.87"	18.86"	19.01"	19.32"	19.37"
25"	23.82"	18.82"	18.87"	19.86"	20.01"	20.32"	20.37"
26"	24.82"	19.82"	19.87"	20.86"	21.01"	21.32"	21.37"
27"	25.82"	20.82"	20.87"	21.86"	22.01"	22.32"	22.37"
28"	26.82"	21.82"	21.87"	22.86"	23.01"	23.32"	23.37"
*29"	27.82"	22.82"	22.87"	23.86"	24.01"	24.32"	24.37"
30"	28.82"	23.82"	23.87"	24.86"	25.01"	25.32"	25.37"
31"	29.82"	24.82"	24.87"	25.86"	26.01"	26.32"	26.37"
32"	30.82"	25.82"	25.87"	26.86"	27.01"	27.32"	27.37"
33"	31.82"	26.82"	26.87"	27.86"	28.01"	28.32"	28.37"
34"	32.82"	27.82"	27.87"	28.86"	29.01"	29.32"	29.37"
35"	33.82"	28.82"	28.87"	29.86"	30.01"	30.32"	30.37"
36"	34.82"	29.82"	29.87"	30.86"	31.01"	31.32"	31.37"
37"	35.82"	30.82"	30.87"	31.86"	32.01"	32.32"	32.37"
38"	36.82"	31.82"	31.87"	32.86"	33.01"	33.32"	33.37"
39"	37.82"	32.82"	32.87"	33.86"	34.01"	34.32"	34.37"
40"	38.82"	33.82"	33.87"	34.86"	35.01"	35.32"	35.37"
41"	39.82"	34.82"	34.87"	35.86"	36.01"	36.32"	36.37"
42"	40.82"	35.82"	35.87"	36.86"	37.01"	37.32"	37.37"

***Note:** Adjustable legs with a height range of 12-19" are shipped from the factory pre-set to 19" table height. Adjustable legs with a height range of 20-42" are shipped from the factory pre-set to 29" table height.

Note: The storage clearance figures shown on the two previous pages are represented with model RDEEA2436. Clearance dimensions in the chart above represent tables with a nominal tabletop thickness of 1 1/4".



STATEMENT OF LINE

Ruckus Post-Leg Rectangular Desk

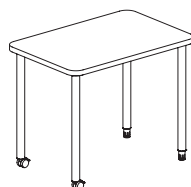

Fixed-Height
 RDEAA2030
 RDEAA2036
 RDEAA2436

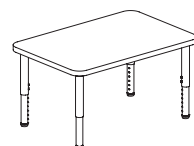

Floor Height Adjustable
 RDEHA2030
 RDEHA2036
 RDEHA2436

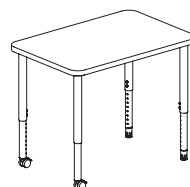

Sit Height Adjustable
 RDEEA2030
 RDEEA2036
 RDEEA2436
 RDEEA2037ADA

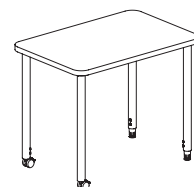

Sit-Stand Height Adjustable
 RDEFA2030
 RDEFA2036
 RDEFA2436
 RDEFA2037ADA

Ruckus Post-Leg E-Triangle Desk

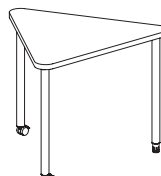

Fixed-Height
 RDEAK32
 RDEAK37

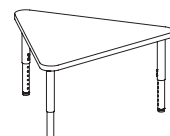

Floor Height Adjustable
 RDEHK32
 RDEHK37



Sit Height Adjustable
 RDEEK32
 RDEEK37

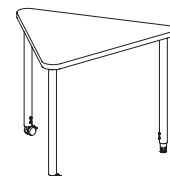

Sit-Stand Height Adjustable
 RDEFK32
 RDEFK37

Ruckus Post-Leg R-Triangle Desk

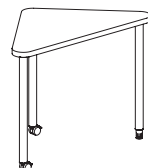

Fixed-Height
 RDEAL39
 RDEAL47

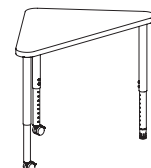

Sit Height Adjustable
 RDEEL39
 RDEEL47

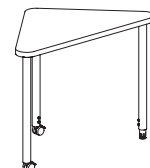

Sit-Stand Height Adjustable
 RDEFL39
 RDEFL47

Ruckus Post-Leg Trapezoid Desk

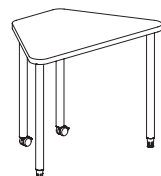

Fixed-Height
 RDEAM34
 RDEAM37

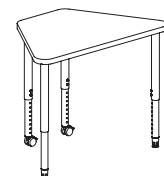

Sit Height Adjustable
 RDEEM34
 RDEEM37



Sit-Stand Height Adjustable
 RDEFM34
 RDEFM37

STATEMENT OF LINE

Ruckus Post-Leg Oddquad Desk

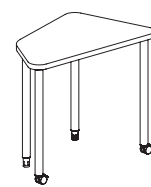

Fixed-Height
 RDEAZ36
 RDEAZ39

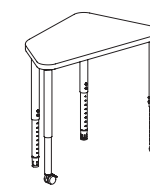

Sit Height Adjustable
 RDEEZ36
 RDEEZ39

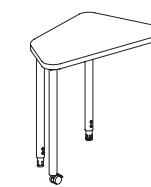

Sit-Stand Height Adjustable
 RDEFZ36
 RDEFZ39

Ruckus Post-Leg Pentaquad Desk

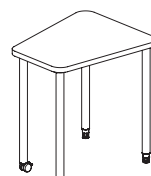

Fixed-Height
 RDEAS2630

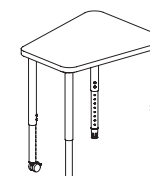

Floor Height Adjustable
 RDEES2630

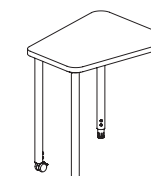

Sit Height Adjustable
 RDEFS2630

Optional Ruckus Post-Leg Desk Storage

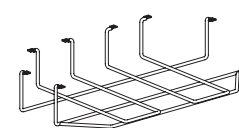

Book Basket
 /BR

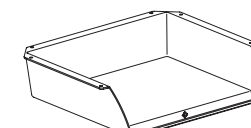

Small Polypropylene Book Box
 /BBS

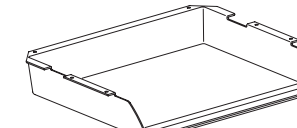

Large Polypropylene Book Box
 /BBL

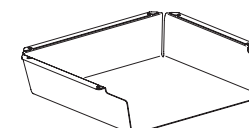

Small Steel Book Box
 /SBBS

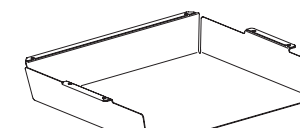

Large Steel Book Box
 /SBBL

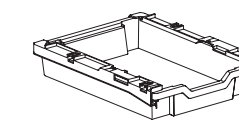

Removable Tote Storage
 /RT

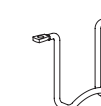

Book Bag Hook
 RKUSBBH1



DIMENSIONS

Ruckus Diamond Activity Table

Model Number	A Table Depth	B Table Width	C Table Height	D Space Between Legs	E Space Between Legs	F	Worksurface Thickness	Fixed Legs	Adjustable Legs	Removable Tote Storage
RTEAE24	31.08"	39.75"	29"	22"	18.19"	24"	3/4" or 1 1/4"	•		0
RTEAE30	38.99"	49.91"	29"	29.06"	24.11"	30"	3/4" or 1 1/4"	•		2
RTEAE36	47.05"	60"	29"	36.24"	29.97"	36"	3/4" or 1 1/4"	•		2
RTEEE24	31.08"	39.75"	20" - 33"	22"	18.19"	24"	3/4" or 1 1/4"		•	0
RTEEE30	38.99"	49.91"	20" - 33"	29.06"	24.11"	30"	3/4" or 1 1/4"		•	2
RTEEE36	47.05"	60"	20" - 33"	36.24"	29.97"	36"	3/4" or 1 1/4"		•	2
RTEFE24	31.08"	39.75"	29" - 42"	29.06"	24.11"	24"	3/4" or 1 1/4"		•	0
RTEFE30	38.99"	49.91"	29" - 42"	36.24"	29.97"	30"	3/4" or 1 1/4"		•	2
RTEFE36	47.05"	60"	29" - 42"	36.24"	29.97"	36"	3/4" or 1 1/4"		•	2

(model RTEEE30 with caster/glide base shown)

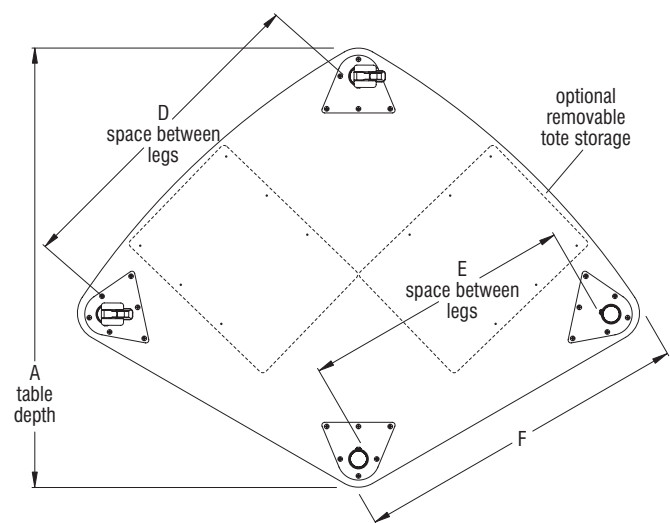

(bottom view)

Note: Table height dimensions in the chart above represent tables with a nominal tabletop thickness of 1 1/4". If the tabletop thickness is 3/4", 1/2" must be subtracted from the "table height" column in the chart. Reference the "Desk/Table Storage Dimensions" charts on pages 9-12 for storage clearance dimensions.

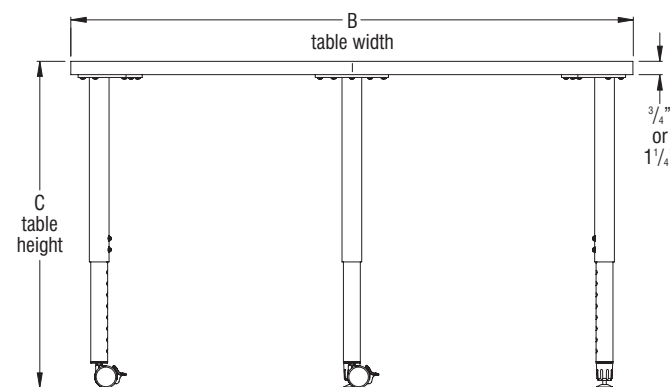

(front view)

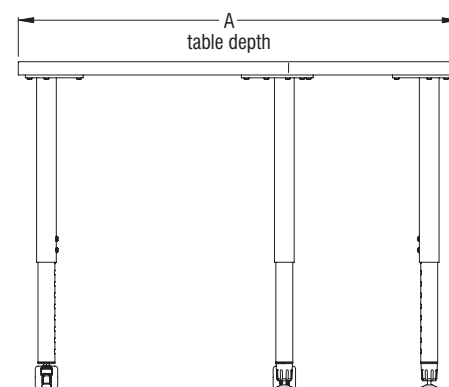

(side view)

DIMENSIONS

Ruckus Kite Activity Table

Model Number	A Table Depth	B Table Width	C Table Height	D Space Between Legs	E	Worksurface Thickness	Fixed Legs	Adjustable Legs	Removable Tote Storage
RTEHJ34-73P	34.89"	56.77"	11 1/2" - 18 1/2"	28.14"	33.83"	3/4"		•	2
RTEHJ39-73P	39.89"	65.43"	11 1/2" - 18 1/2"	33.14"	38.83"	3/4"		•	2
RTEAJ34	34.89"	56.77"	29"	28.14"	33.83"	3/4" or 1 1/4"	•		2
RTEAJ39	39.89"	65.43"	29"	33.14"	38.83"	3/4" or 1 1/4"	•		2
RTEEJ34	34.89"	56.77"	20" - 33"	28.14"	33.83"	3/4" or 1 1/4"		•	2
RTEEJ39	39.89"	65.43"	20" - 33"	33.14"	38.83"	3/4" or 1 1/4"		•	2
RTEFJ34	34.89"	56.77"	29" - 42"	28.14"	33.83"	3/4" or 1 1/4"		•	2
RTEFJ39	39.89"	65.43"	29" - 42"	33.14"	38.83"	3/4" or 1 1/4"		•	2

(model RDEEJ34 with caster/glide base shown)

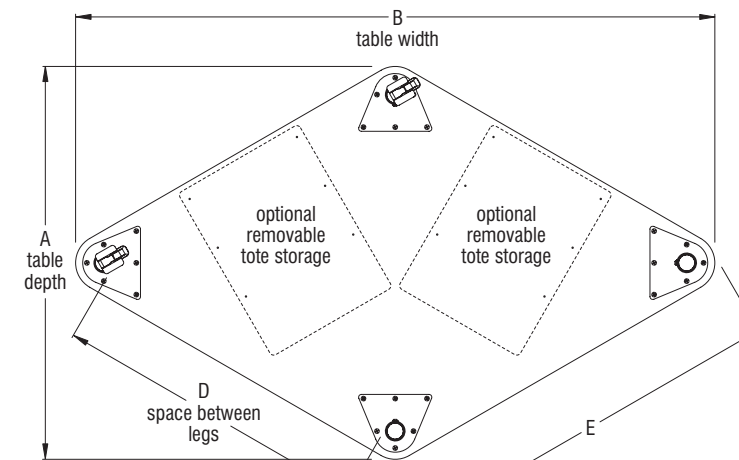

(bottom view)

Note: Table height dimensions in the chart above (excluding RTEHJ models) represent tables with a nominal tabletop thickness of 1 1/4". If the tabletop thickness is 3/4", 1/2" must be subtracted from the "table height" column in the chart. Reference the "Desk/Table Storage Dimensions" charts on pages 9-12 for storage clearance dimensions.

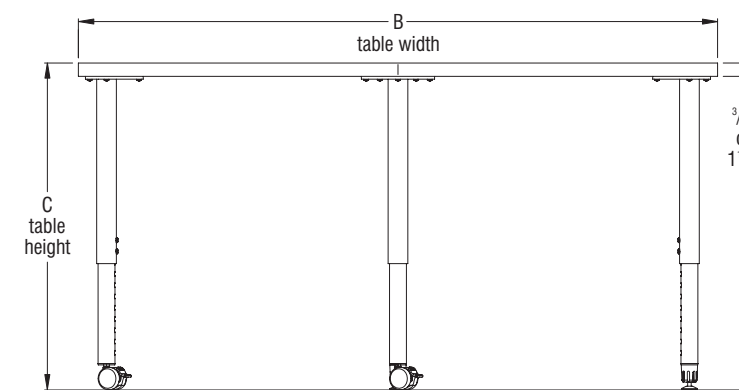

(front view)

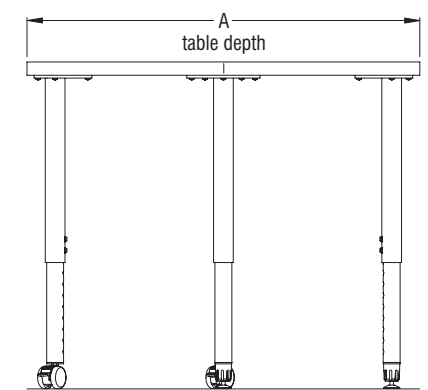

(side view)



DIMENSIONS

Ruckus Rectangular Activity Table with Rounded Corners - Fixed-Height

Model Number	A Table Depth	B Table Width	C Table Height	D Space Between Legs	E Space Between Legs	Worksurface Thickness	Single Stiffener	Dual Stiffener	Middle Leg	Removable Tote Storage
RTEAA2048	20"	48"	29"	41.37"	13.37"	1 1/4"				2
RTEAA2054	20"	54"	29"	47.37"	13.37"	1 1/4"				2
RTEAA2060	20"	60"	29"	53.37"	13.37"	1 1/4"	•			2
RTEAA2066	20"	66"	29"	59.37"	13.37"	1 1/4"	•			2
RTEAA2072	20"	72"	29"	65.37"	13.37"	1 1/4"	•			3
RTEAA2430	24"	30"	29"	23.37"	17.37"	1 1/4"				0
RTEAA2436	24"	36"	29"	29.37"	17.37"	1 1/4"				1
RTEAA2448	24"	48"	29"	41.37"	17.37"	1 1/4"				2
RTEAA2454	24"	54"	29"	47.37"	17.37"	1 1/4"				2
RTEAA2460	24"	60"	29"	53.37"	17.37"	1 1/4"	•			2
RTEAA2466	24"	66"	29"	59.37"	17.37"	1 1/4"	•			2
RTEAA2472	24"	72"	29"	65.37"	17.37"	1 1/4"	•			3
RTEAA3048	30"	48"	29"	41.37"	23.37"	1 1/4"				2
RTEAA3054	30"	54"	29"	47.37"	23.37"	1 1/4"				2
RTEAA3060	30"	60"	29"	53.37"	23.37"	1 1/4"	•			2
RTEAA3066	30"	66"	29"	59.37"	23.37"	1 1/4"	•			2
RTEAA3072	30"	72"	29"	65.37"	23.37"	1 1/4"	•			3
RTEAA3654	36"	54"	29"	47.37"	29.37"	1 1/4"				2
RTEAA3660	36"	60"	29"	53.37"	29.37"	1 1/4"		•		4
RTEAA3666	36"	66"	29"	59.37"	29.37"	1 1/4"		•		4
RTEAA3672	36"	72"	29"	65.37"	29.37"	1 1/4"		•		6
RTEAA4260	42"	60"	29"	53.37"	35.37"	1 1/4"		•		4
RTEAA4266	42"	66"	29"	59.37"	35.37"	1 1/4"		•		4
RTEAA4272	42"	72"	29"	65.37"	35.37"	1 1/4"		•	•	6
RTEAA4460	44"	60"	29"	53.37"	37.37"	1 1/4"		•		4
RTEAA4466	44"	66"	29"	59.37"	37.37"	1 1/4"		•		4
RTEAA4472	44"	72"	29"	65.37"	37.37"	1 1/4"		•	•	6
RTEAA4860	48"	60"	29"	53.37"	41.37"	1 1/4"		•		4
RTEAA4866	48"	66"	29"	59.37"	41.37"	1 1/4"		•		4
RTEAA4872	48"	72"	29"	65.37"	41.37"	1 1/4"		•	•	8

(model RTEAA2048 with caster/glide base shown)

Note: Table height dimensions in the chart above represent tables with a nominal tabletop thickness of 1 1/4". Reference the "Desk/Table Storage Dimensions" charts on pages 9-12 for storage clearance dimensions.

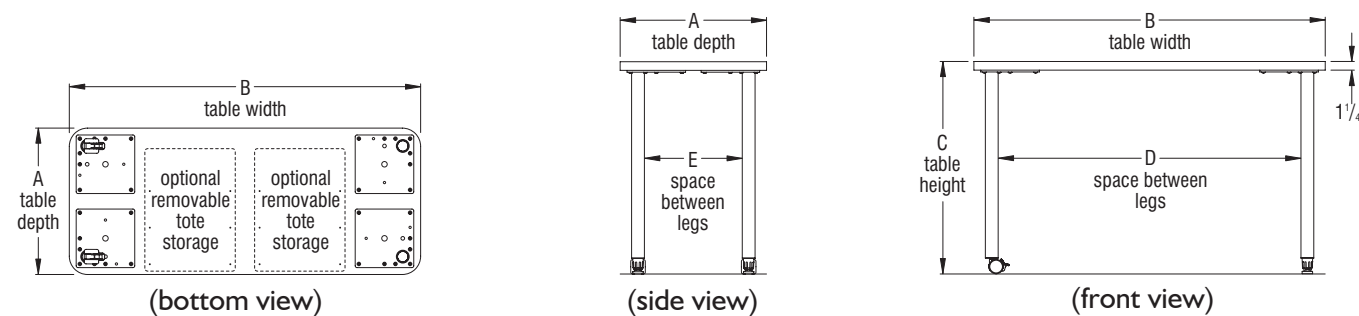

DIMENSIONS

Ruckus Rectangular Activity Table with Rounded Corners - Floor Adjustable-Height

Model Number	A Table Depth	B Table Width	C Table Height	D Space Between Legs	E Space Between Legs	Worksurface Thickness	Single Stiffener	Dual Stiffener	Middle Leg	Removable Tote Storage
RTEHA2048	20"	48"	12" - 19"	41.37"	13.37"	1 1/4"				2
RTEHA2054	20"	54"	12" - 19"	47.37"	13.37"	1 1/4"				2
RTEHA2060	20"	60"	12" - 19"	53.37"	13.37"	1 1/4"	•			2
RTEHA2066	20"	66"	12" - 19"	59.37"	13.37"	1 1/4"	•			2
RTEHA2072	20"	72"	12" - 19"	65.37"	13.37"	1 1/4"	•			3
RTEHA2436	24"	36"	12" - 19"	29.37"	17.37"	1 1/4"				1
RTEHA2442	24"	42"	12" - 19"	35.37"	17.37"	1 1/4"				2
RTEHA2448	24"	48"	12" - 19"	41.37"	17.37"	1 1/4"				2
RTEHA2454	24"	54"	12" - 19"	47.37"	17.37"	1 1/4"				2
RTEHA2460	24"	60"	12" - 19"	53.37"	17.37"	1 1/4"	•			2
RTEHA2466	24"	66"	12" - 19"	59.37"	17.37"	1 1/4"	•			2
RTEHA2472	24"	72"	12" - 19"	65.37"	17.37"	1 1/4"	•			3
RTEHA3042	30"	42"	12" - 19"	35.37"	23.37"	1 1/4"				2
RTEHA3048	30"	48"	12" - 19"	41.37"	23.37"	1 1/4"				2
RTEHA3054	30"	54"	12" - 19"	47.37"	23.37"	1 1/4"				2
RTEHA3060	30"	60"	12" - 19"	53.37"	23.37"	1 1/4"	•			2
RTEHA3066	30"	66"	12" - 19"	59.37"	23.37"	1 1/4"	•			2
RTEHA3072	30"	72"	12" - 19"	65.37"	23.37"	1 1/4"	•			3
RTEHA3654	36"	54"	12" - 19"	47.37"	29.37"	1 1/4"				2
RTEHA3660	36"	60"	12" - 19"	53.37"	29.37"	1 1/4"		•		4
RTEHA3666	36"	66"	12" - 19"	59.37"	29.37"	1 1/4"		•		4
RTEHA3672	36"	72"	12" - 19"	65.37"	29.37"	1 1/4"		•		6

(model RTEHA2048 with caster/glide base shown)

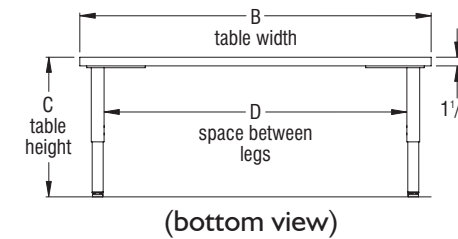

Note: Table height dimensions in the chart above represent tables with a nominal tabletop thickness of 1 1/4". Reference the "Desk/Table Storage Dimensions" charts on pages 9-12 for storage clearance dimensions.

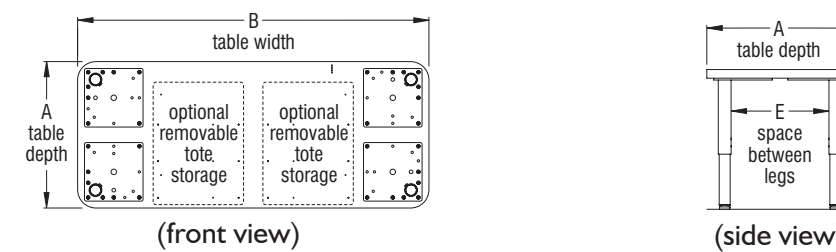



DIMENSIONS

Ruckus Rectangular Activity Table with Rounded Corners - Sit Adjustable-Height

Model Number	A Table Depth	B Table Width	C Table Height	D Space Between Legs	E Space Between Legs	Worksurface Thickness	Single Stiffener	Dual Stiffener	Middle Leg	Removable Tote Storage
RTEEA2048	20"	48"	20" - 33"	41.37"	13.37"	1 1/4"				2
RTEEA2054	20"	54"	20" - 33"	47.37"	13.37"	1 1/4"				2
RTEEA2060	20"	60"	20" - 33"	53.37"	13.37"	1 1/4"	•			2
RTEEA2066	20"	66"	20" - 33"	59.37"	13.37"	1 1/4"	•			2
RTEEA2072	20"	72"	20" - 33"	65.37"	13.37"	1 1/4"	•			3
RTEEA2430	24"	30"	20" - 33"	23.37"	17.37"	1 1/4"				0
RTEEA2436	24"	36"	20" - 33"	29.37"	17.37"	1 1/4"				1
RTEEA2448	24"	48"	20" - 33"	41.37"	17.37"	1 1/4"				2
RTEEA2454	24"	54"	20" - 33"	47.37"	17.37"	1 1/4"				2
RTEEA2460	24"	60"	20" - 33"	53.37"	17.37"	1 1/4"	•			2
RTEEA2466	24"	66"	20" - 33"	59.37"	17.37"	1 1/4"	•			2
RTEEA2472	24"	72"	20" - 33"	65.37"	17.37"	1 1/4"	•			3
RTEEA3048	30"	48"	20" - 33"	41.37"	23.37"	1 1/4"				2
RTEEA3054	30"	54"	20" - 33"	47.37"	23.37"	1 1/4"				2
RTEEA3060	30"	60"	20" - 33"	53.37"	23.37"	1 1/4"	•			2
RTEEA3066	30"	66"	20" - 33"	59.37"	23.37"	1 1/4"	•			2
RTEEA3072	30"	72"	20" - 33"	65.37"	23.37"	1 1/4"	•			3
RTEEA3654	36"	54"	20" - 33"	47.37"	29.37"	1 1/4"				2
RTEEA3660	36"	60"	20" - 33"	53.37"	29.37"	1 1/4"		•		4
RTEEA3666	36"	66"	20" - 33"	59.37"	29.37"	1 1/4"		•		4
RTEEA3672	36"	72"	20" - 33"	65.37"	29.37"	1 1/4"		•		6
RTEEA4260	42"	60"	20" - 33"	53.37"	35.37"	1 1/4"		•		4
RTEEA4266	42"	66"	20" - 33"	59.37"	35.37"	1 1/4"		•		4
RTEEA4272	42"	72"	20" - 33"	65.37"	35.37"	1 1/4"		•	•	6
RTEEA4460	44"	60"	20" - 33"	53.37"	37.37"	1 1/4"		•		4
RTEEA4466	44"	66"	20" - 33"	59.37"	37.37"	1 1/4"		•		4
RTEEA4472	44"	72"	20" - 33"	65.37"	37.37"	1 1/4"		•	•	6
RTEEA4860	48"	60"	20" - 33"	53.37"	41.37"	1 1/4"		•		4
RTEEA4866	48"	66"	20" - 33"	59.37"	41.37"	1 1/4"		•		4
RTEEA4872	48"	72"	20" - 33"	65.37"	41.37"	1 1/4"		•	•	8

(model RTEEA2048 with caster/glide base shown)

Note: Table height dimensions in the chart above represent tables with a nominal tabletop thickness of 1 1/4". Reference the "Desk/Table Storage Dimensions" charts on pages 9-12 for storage clearance dimensions.

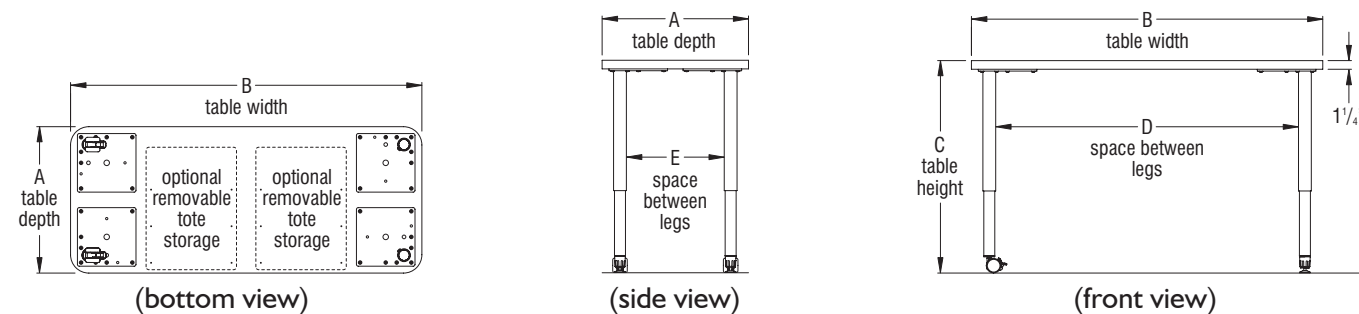

DIMENSIONS

Ruckus Rectangular Activity Table with Rounded Corners - Sit-Stand Adjustable-Height

Model Number	A Table Depth	B Table Width	C Table Height	D Space Between Legs	E Space Between Legs	Worksurface Thickness	Single Stiffener	Dual Stiffeners	Middle Leg	Removable Tote Storage
RTEFA2048	20"	48"	29" - 42"	41.37"	13.37"	1 1/4"				2
RTEFA2054	20"	54"	29" - 42"	47.37"	13.37"	1 1/4"				2
RTEFA2060	20"	60"	29" - 42"	53.37"	13.37"	1 1/4"	•			2
RTEFA2066	20"	66"	29" - 42"	59.37"	13.37"	1 1/4"	•			2
RTEFA2072	20"	72"	29" - 42"	65.37"	13.37"	1 1/4"	•			3
RTEFA2430	24"	30"	29" - 42"	23.37"	17.37"	1 1/4"				0
RTEFA2436	24"	36"	29" - 42"	29.37"	17.37"	1 1/4"				1
RTEFA2448	24"	48"	29" - 42"	41.37"	17.37"	1 1/4"				2
RTEFA2454	24"	54"	29" - 42"	47.37"	17.37"	1 1/4"				2
RTEFA2460	24"	60"	29" - 42"	53.37"	17.37"	1 1/4"	•			2
RTEFA2466	24"	66"	29" - 42"	59.37"	17.37"	1 1/4"	•			2
RTEFA2472	24"	72"	29" - 42"	65.37"	17.37"	1 1/4"	•			3
RTEFA3048	30"	48"	29" - 42"	41.37"	23.37"	1 1/4"				2
RTEFA3054	30"	54"	29" - 42"	47.37"	23.37"	1 1/4"				2
RTEFA3060	30"	60"	29" - 42"	53.37"	23.37"	1 1/4"	•			2
RTEFA3066	30"	66"	29" - 42"	59.37"	23.37"	1 1/4"	•			2
RTEFA3072	30"	72"	29" - 42"	65.37"	23.37"	1 1/4"	•			3
RTEFA3654	36"	54"	29" - 42"	47.37"	29.37"	1 1/4"				2
RTEFA3660	36"	60"	29" - 42"	53.37"	29.37"	1 1/4"		•		4
RTEFA3666	36"	66"	29" - 42"	59.37"	29.37"	1 1/4"		•		4
RTEFA3672	36"	72"	29" - 42"	65.37"	29.37"	1 1/4"		•		6
RTEFA4260	42"	60"	29" - 42"	53.37"	35.37"	1 1/4"		•		4
RTEFA4266	42"	66"	29" - 42"	59.37"	37.37"	1 1/4"		•		4
RTEFA4272	42"	72"	29" - 42"	65.37"	35.37"	1 1/4"		•	•	6
RTEFA4460	44"	60"	29" - 42"	53.37"	37.37"	1 1/4"		•		4
RTEFA4466	44"	66"	29" - 42"	59.37"	37.37"	1 1/4"		•		4
RTEFA4472	44"	72"	29" - 42"	65.37"	37.37"	1 1/4"		•	•	6
RTEFA4860	48"	60"	29" - 42"	53.37"	41.37"	1 1/4"		•		4
RTEFA4866	48"	66"	29" - 42"	59.37"	41.37"	1 1/4"		•		4
RTEFA4872	48"	72"	29" - 42"	65.37"	41.37"	1 1/4"		•	•	8

(model RTEFA2048 with caster/glide base shown)

Note: Table height dimensions in the chart above represent tables with a nominal tabletop thickness of 1 1/4". Reference the "Desk/Table Storage Dimensions" charts on pages 9-12 for storage clearance dimensions.

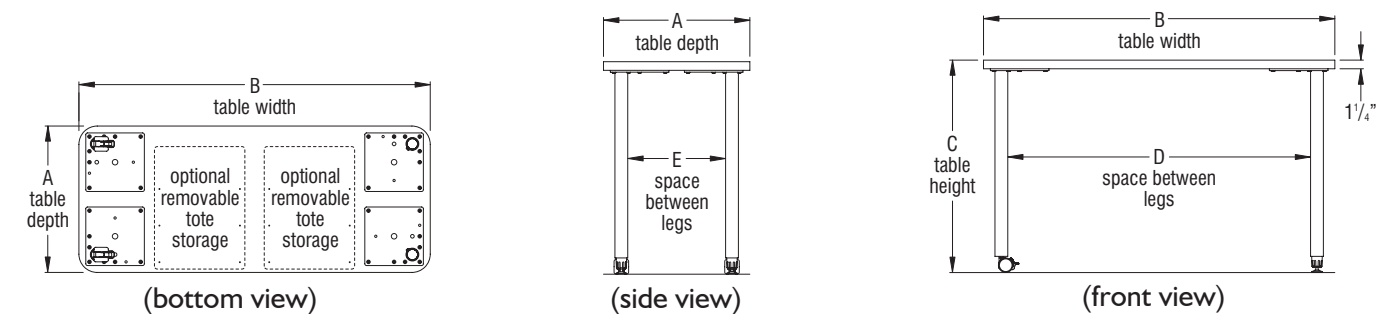



DIMENSIONS

Ruckus Rectangular Activity Table with Square Corners - Fixed-Height

Model Number	A Table Depth	B Table Width	C Table Height	D Space Between Legs	E Space Between Legs	Worksurface Thickness	Single Stiffener	Dual Stiffener	Middle Leg	Removable Tote Storage
RXEEA2048	20"	48"	12" - 19"	41.37"	13.37"	1 1/4"				2
RXEEA2054	20"	54"	12" - 19"	47.37"	13.37"	1 1/4"				2
RXEEA2060	20"	60"	12" - 19"	53.37"	13.37"	1 1/4"	•			2
RXEEA2066	20"	66"	12" - 19"	59.37"	13.37"	1 1/4"	•			2
RXEEA2072	20"	72"	12" - 19"	65.37"	13.37"	1 1/4"	•			3
RXEEA2430	24"	30"	12" - 19"	23.37"	17.37"	1 1/4"				0
RXEEA2436	24"	36"	12" - 19"	29.37"	17.37"	1 1/4"				1
RXEEA2448	24"	48"	12" - 19"	41.37"	17.37"	1 1/4"				2
RXEEA2454	24"	54"	12" - 19"	47.37"	17.37"	1 1/4"				2
RXEEA2460	24"	60"	12" - 19"	53.37"	17.37"	1 1/4"	•			2
RXEEA2466	24"	66"	12" - 19"	59.37"	17.37"	1 1/4"	•			2
RXEEA2472	24"	72"	12" - 19"	65.37"	17.37"	1 1/4"	•			3
RXEEA3048	30"	48"	12" - 19"	41.37"	23.37"	1 1/4"				2
RXEEA3054	30"	54"	12" - 19"	47.37"	23.37"	1 1/4"				2
RXEEA3060	30"	60"	12" - 19"	53.37"	23.37"	1 1/4"	•			2
RXEEA3066	30"	66"	12" - 19"	59.37"	23.37"	1 1/4"	•			2
RXEEA3072	30"	72"	12" - 19"	65.37"	23.37"	1 1/4"	•			3
RXEEA3654	36"	54"	12" - 19"	47.37"	29.37"	1 1/4"				2
RXEEA3660	36"	60"	12" - 19"	53.37"	29.37"	1 1/4"		•		4
RXEEA3666	36"	66"	12" - 19"	59.37"	29.37"	1 1/4"		•		4
RXEEA3672	36"	72"	12" - 19"	65.37"	29.37"	1 1/4"		•		6
RXEEA4260	42"	60"	12" - 19"	53.37"	35.37"	1 1/4"		•		4
RXEEA4266	42"	66"	12" - 19"	59.37"	35.37"	1 1/4"		•		4
RXEEA4272	42"	72"	12" - 19"	65.37"	35.37"	1 1/4"		•	•	6
RXEEA4460	44"	60"	12" - 19"	53.37"	37.37"	1 1/4"		•		4
RXEEA4466	44"	66"	12" - 19"	59.37"	37.37"	1 1/4"		•		4
RXEEA4472	44"	72"	12" - 19"	65.37"	37.37"	1 1/4"		•	•	6
RXEEA4860	48"	60"	12" - 19"	53.37"	41.37"	1 1/4"		•		4
RXEEA4866	48"	66"	12" - 19"	59.37"	41.37"	1 1/4"		•		4
RXEEA4872	48"	72"	12" - 19"	65.37"	41.37"	1 1/4"		•	•	8

(model RXEAA2048 with caster/glide base shown)

Note: Table height dimensions in the chart above represent tables with a nominal tabletop thickness of 1 1/4". Reference the "Desk/Table Storage Dimensions" charts on pages 9-12 for storage clearance dimensions.

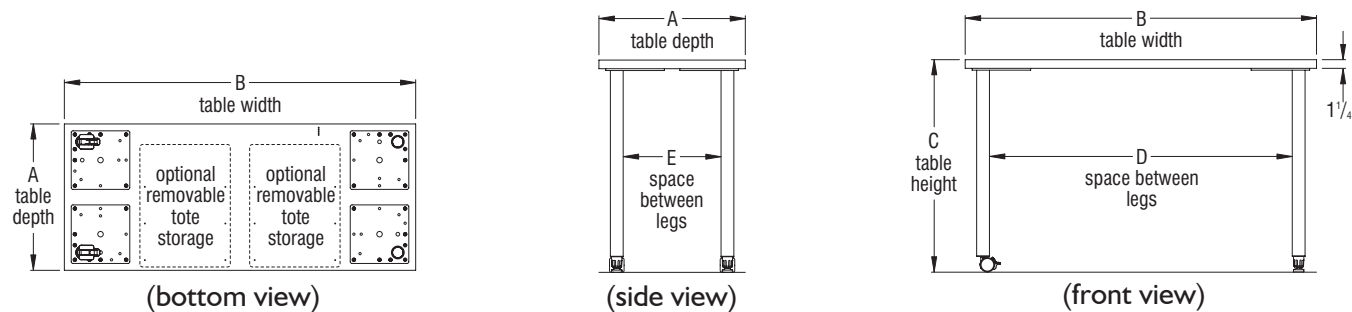

DIMENSIONS

Ruckus Rectangular Activity Table with Square Corners - Sit Adjustable-Height

Model Number	A Table Depth	B Table Width	C Table Height	D Space Between Legs	E Space Between Legs	Worksurface Thickness	Single Stiffener	Dual Stiffener	Middle Leg	Removable Tote Storage
RXEEA2048	20"	48"	20" - 33"	41.37"	13.37"	1 1/4"				2
RXEEA2054	20"	54"	20" - 33"	47.37"	13.37"	1 1/4"				2
RXEEA2060	20"	60"	20" - 33"	53.37"	13.37"	1 1/4"	•			2
RXEEA2066	20"	66"	20" - 33"	59.37"	13.37"	1 1/4"	•			2
RXEEA2072	20"	72"	20" - 33"	65.37"	13.37"	1 1/4"	•			3
RXEEA2430	24"	30"	20" - 33"	23.37"	17.37"	1 1/4"				0
RXEEA2436	24"	36"	20" - 33"	29.37"	17.37"	1 1/4"				1
RXEEA2448	24"	48"	20" - 33"	41.37"	17.37"	1 1/4"				2
RXEEA2454	24"	54"	20" - 33"	47.37"	17.37"	1 1/4"				2
RXEEA2460	24"	60"	20" - 33"	53.37"	17.37"	1 1/4"	•			2
RXEEA2466	24"	66"	20" - 33"	59.37"	17.37"	1 1/4"	•			2
RXEEA2472	24"	72"	20" - 33"	65.37"	17.37"	1 1/4"	•			3
RXEEA3048	30"	48"	20" - 33"	41.37"	23.37"	1 1/4"				2
RXEEA3054	30"	54"	20" - 33"	47.37"	23.37"	1 1/4"				2
RXEEA3060	30"	60"	20" - 33"	53.37"	23.37"	1 1/4"	•			2
RXEEA3066	30"	66"	20" - 33"	59.37"	23.37"	1 1/4"	•			2
RXEEA3072	30"	72"	20" - 33"	65.37"	23.37"	1 1/4"	•			3
RXEEA3654	36"	54"	20" - 33"	47.37"	29.37"	1 1/4"				2
RXEEA3660	36"	60"	20" - 33"	53.37"	29.37"	1 1/4"		•		4
RXEEA3666	36"	66"	20" - 33"	59.37"	29.37"	1 1/4"		•		4
RXEEA3672	36"	72"	20" - 33"	65.37"	29.37"	1 1/4"		•		6
RXEEA4260	42"	60"	20" - 33"	53.37"	35.37"	1 1/4"		•		4
RXEEA4266	42"	66"	20" - 33"	59.37"	35.37"	1 1/4"		•		4
RXEEA4272	42"	72"	20" - 33"	65.37"	35.37"	1 1/4"		•	•	6
RXEEA4460	44"	60"	20" - 33"	53.37"	37.37"	1 1/4"		•		4
RXEEA4466	44"	66"	20" - 33"	59.37"	37.37"	1 1/4"		•		4
RXEEA4472	44"	72"	20" - 33"	65.37"	37.37"	1 1/4"		•	•	6
RXEEA4860	48"	60"	20" - 33"	53.37"	41.37"	1 1/4"		•		4
RXEEA4866	48"	66"	20" - 33"	59.37"	41.37"	1 1/4"		•		4
RXEEA4872	48"	72"	20" - 33"	65.37"	41.37"	1 1/4"		•	•	8

(model RXEEA2048 with caster/glide base shown)

Note: Table height dimensions in the chart above represent tables with a nominal tabletop thickness of 1 1/4". Reference the "Desk/Table Storage Dimensions" charts on pages 9-12 for storage clearance dimensions.

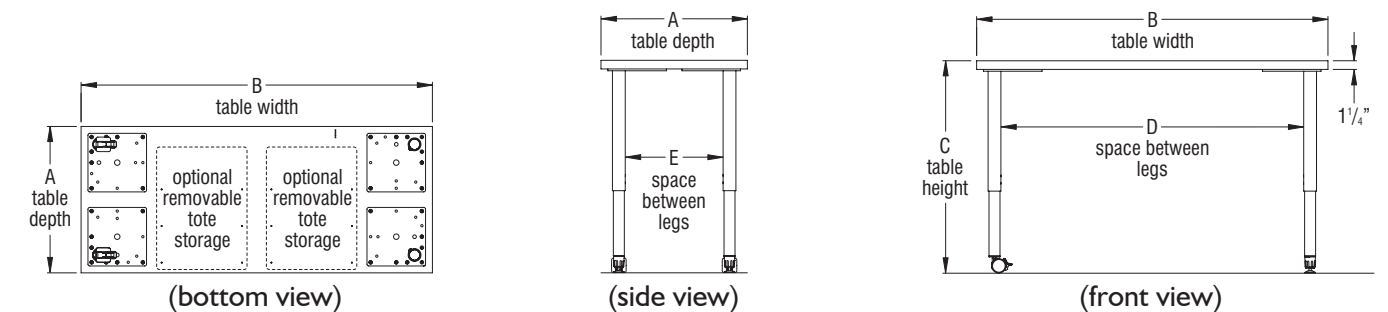



DIMENSIONS

Ruckus Rectangular Activity Table with Square Corners - Sit-Stand Adjustable-Height

Model Number	A Table Depth	B Table Width	C Table Height	D Space Between Legs	E Space Between Legs	Worksurface Thickness	Single Stiffener	Dual Stiffeners	Middle Leg	Removable Tote Storage
RXEFA2048	20"	48"	29" - 42"	41.37"	13.37"	1 1/4"				2
RXEFA2054	20"	54"	29" - 42"	47.37"	13.37"	1 1/4"				2
RXEFA2060	20"	60"	29" - 42"	53.37"	13.37"	1 1/4"	•			2
RXEFA2066	20"	66"	29" - 42"	59.37"	13.37"	1 1/4"	•			2
RXEFA2072	20"	72"	29" - 42"	65.37"	13.37"	1 1/4"	•			3
RXEFA2430	24"	30"	29" - 42"	23.37"	17.37"	1 1/4"				0
RXEFA2436	24"	36"	29" - 42"	29.37"	17.37"	1 1/4"				1
RXEFA2448	24"	48"	29" - 42"	41.37"	17.37"	1 1/4"				2
RXEFA2454	24"	54"	29" - 42"	47.37"	17.37"	1 1/4"				2
RXEFA2460	24"	60"	29" - 42"	53.37"	17.37"	1 1/4"	•			2
RXEFA2466	24"	66"	29" - 42"	59.37"	17.37"	1 1/4"	•			2
RXEFA2472	24"	72"	29" - 42"	65.37"	17.37"	1 1/4"	•			3
RXEFA3048	30"	48"	29" - 42"	41.37"	23.37"	1 1/4"				2
RXEFA3054	30"	54"	29" - 42"	47.37"	23.37"	1 1/4"				2
RXEFA3060	30"	60"	29" - 42"	53.37"	23.37"	1 1/4"	•			2
RXEFA3066	30"	66"	29" - 42"	59.37"	23.37"	1 1/4"	•			2
RXEFA3072	30"	72"	29" - 42"	65.37"	23.37"	1 1/4"	•			3
RXEFA3654	36"	54"	29" - 42"	47.37"	29.37"	1 1/4"				2
RXEFA3660	36"	60"	29" - 42"	53.37"	29.37"	1 1/4"		•		4
RXEFA3666	36"	66"	29" - 42"	59.37"	29.37"	1 1/4"		•		4
RXEFA3672	36"	72"	29" - 42"	65.37"	29.37"	1 1/4"		•		6
RXEFA4260	42"	60"	29" - 42"	53.37"	35.37"	1 1/4"		•		4
RXEFA4266	42"	66"	29" - 42"	59.37"	37.37"	1 1/4"		•		4
RXEFA4272	42"	72"	29" - 42"	65.37"	35.37"	1 1/4"		•	•	6
RXEFA4460	44"	60"	29" - 42"	53.37"	37.37"	1 1/4"		•		4
RXEFA4466	44"	66"	29" - 42"	59.37"	37.37"	1 1/4"		•		4
RXEFA4472	44"	72"	29" - 42"	65.37"	37.37"	1 1/4"		•	•	6
RXEFA4860	48"	60"	29" - 42"	53.37"	41.37"	1 1/4"		•		4
RXEFA4866	48"	66"	29" - 42"	59.37"	41.37"	1 1/4"		•		4
RXEFA4872	48"	72"	29" - 42"	65.37"	41.37"	1 1/4"		•	•	8

(model RXEFA2048 with caster/glide base shown)

Note: Table height dimensions in the chart above represent tables with a nominal tabletop thickness of 1 1/4". Reference the "Desk/Table Storage Dimensions" charts on pages 9-12 for storage clearance dimensions.

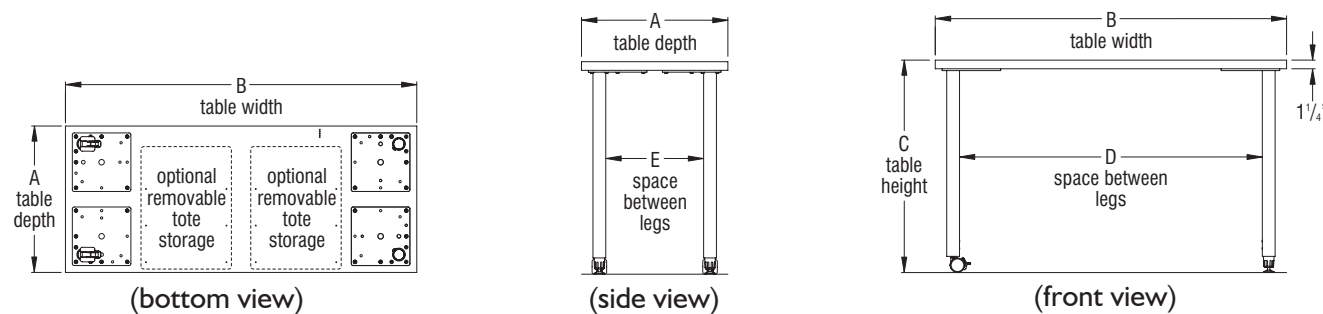

DIMENSIONS

Ruckus Round Activity Table

Model Number	A Table Diameter	B Table Height	C Space Between Legs	Worksurface Thickness	Fixed Legs	Adjustable Legs	Removable Tote Storage
RTEHB36	36"	12" - 19"	20.29"	1 1/4"		•	0
RTEHB42	42"	12" - 19"	24.53"	1 1/4"		•	0
RTEHB48	48"	12" - 19"	28.78"	1 1/4"		•	4
RTEHB60	60"	12" - 19"	37.26"	1 1/4"		•	4
RTEAB36	36"	29"	20.29"	1 1/4"	•		0
RTEAB42	42"	29"	24.53"	1 1/4"	•		0
RTEAB48	48"	29"	28.78"	1 1/4"	•		4
RTEAB60	60"	29"	37.26"	1 1/4"	•		4
RTEEB36	36"	20" - 33"	20.29"	1 1/4"		•	0
RTEEB42	42"	20" - 33"	24.53"	1 1/4"		•	0
RTEEB48	48"	20" - 33"	28.78"	1 1/4"		•	4
RTEEB60	60"	20" - 33"	37.26"	1 1/4"		•	4
RTEFB36	36"	29" - 42"	20.29"	1 1/4"		•	0
RTEFB42	42"	29" - 42"	24.53"	1 1/4"		•	0
RTEFB48	48"	29" - 42"	28.78"	1 1/4"		•	4
RTEFB60	60"	29" - 42"	37.26"	1 1/4"		•	4

(model RTEEB48 with caster/glide base shown)

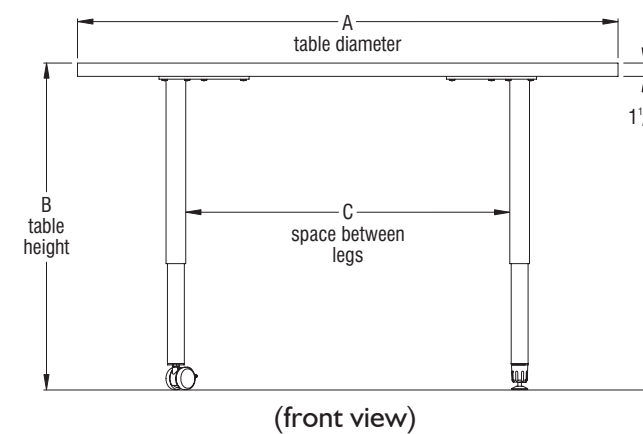

(front view)

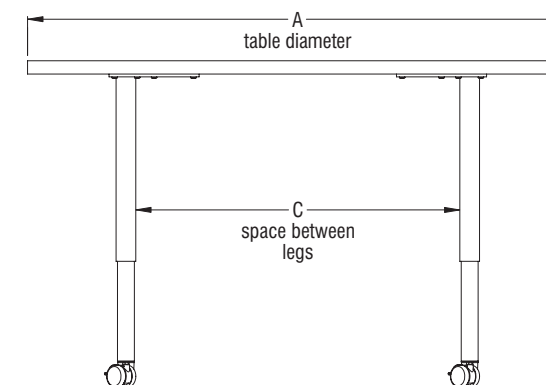

(side view)

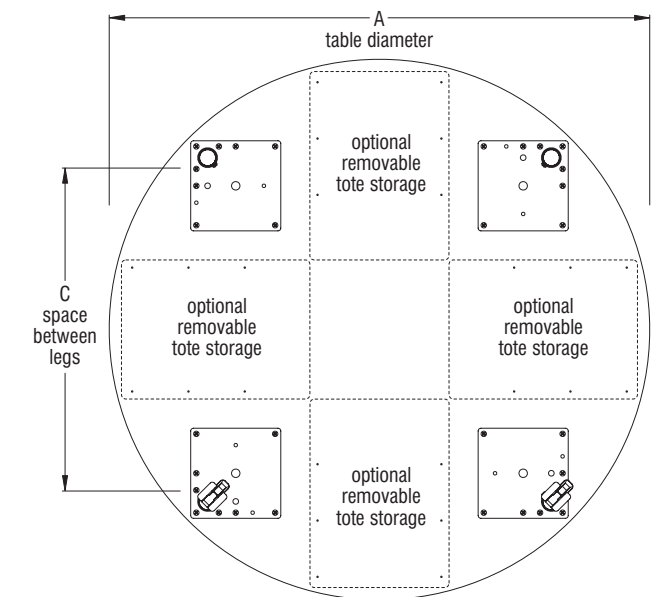

(bottom view)

Note: Table height dimensions in the chart above represent tables with a nominal tabletop thickness of 1 1/4". Reference the "Desk/Table Storage Dimensions" charts on pages 9-12 for storage clearance dimensions.



DIMENSIONS

Ruckus Square Activity Table

Model Number	A Table Width	B Table Height	C Space Between Legs	Worksurface Thickness	Fixed Legs	Adjustable Legs	Removable Tote Storage
RTEHC30	30"	12" - 19"	23.37"	1 1/4"		•	0
RTEHC36	36"	12" - 19"	29.37"	1 1/4"		•	2
RTEHC42	42"	12" - 19"	35.37"	1 1/4"		•	2
RTEHC48	48"	12" - 19"	41.37"	1 1/4"		•	4
RTEAC30	30"	29"	23.37"	1 1/4"	•		0
RTEAC36	36"	29"	29.37"	1 1/4"	•		2
RTEAC42	42"	29"	35.37"	1 1/4"	•		2
RTEAC48	48"	29"	41.37"	1 1/4"	•		4
RTEEC30	30"	20" - 33"	23.37"	1 1/4"		•	0
RTEEC36	36"	20" - 33"	29.37"	1 1/4"		•	2
RTEEC42	42"	20" - 33"	35.37"	1 1/4"		•	2
RTEEC48	48"	20" - 33"	41.37"	1 1/4"		•	4
RTEFC30	30"	29" - 42"	23.37"	1 1/4"		•	0
RTEFC36	36"	29" - 42"	29.37"	1 1/4"		•	2
RTEFC42	42"	29" - 42"	35.37"	1 1/4"		•	2
RTEFC48	48"	29" - 42"	41.37"	1 1/4"		•	4

(model RTEEC36 with caster/glide base shown)

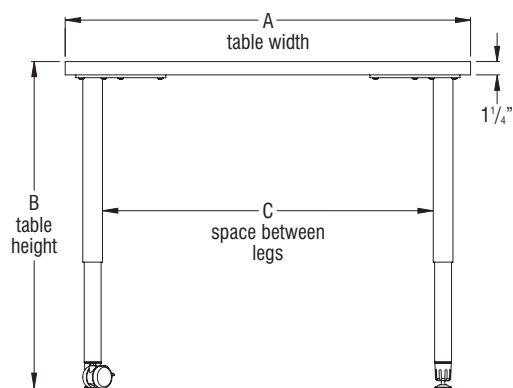

(front view)

Note: Table height dimensions in the chart above represent tables with a nominal tabletop thickness of 1 1/4". Reference the "Desk/Table Storage Dimensions" charts on pages 9-12 for storage clearance dimensions.

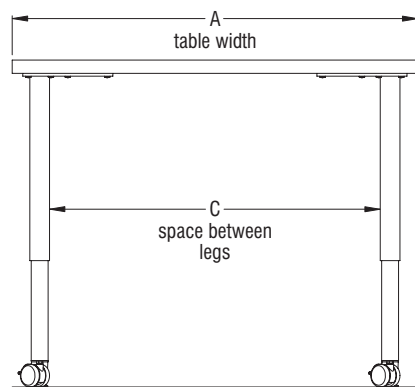

(side view)

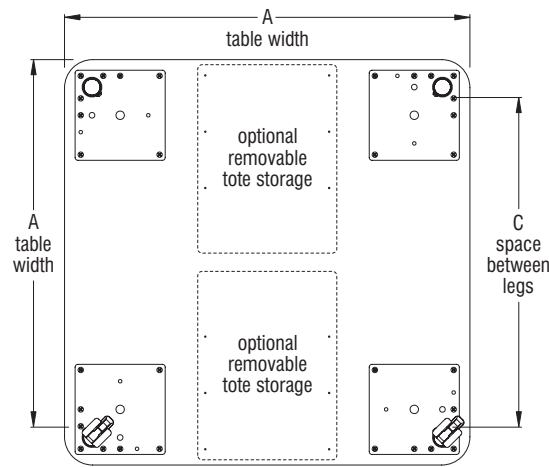

(bottom view)

DIMENSIONS

Ruckus D-Shaped Activity Table

Model Number	A Table Depth	B Table Width	C Table Height	D Space Between Legs	E Space Between Legs	F Space Between Legs	Worksurface Thickness	Fixed Legs	Adjustable Legs	Dual Stiffeners	Removable Tote Storage
RTEAD4260	42"	60"	29"	46.81"	36.25"	26.84"	1 1/4"	•		•	5
RTEAD4860	48"	60"	29"	45.74"	41.37"	31.46"	1 1/4"	•		•	5
RTEAD4872	48"	72"	29"	57.74"	41.37"	31.46"	1 1/4"	•		•	5
RTEAD6072	60"	72"	29"	55.61"	53.37"	40.68"	1 1/4"	•		•	5
RTEED4260	42"	60"	20" - 33"	46.81"	36.25"	26.84"	1 1/4"		•	•	5
RTEED4860	48"	60"	20" - 33"	45.74"	41.37"	31.46"	1 1/4"		•	•	5
RTEED4872	48"	72"	20" - 33"	57.74"	41.37"	31.46"	1 1/4"		•	•	5
RTEED6072	60"	72"	20" - 33"	55.61"	53.37"	40.68"	1 1/4"		•	•	5
RTEFD4260	42"	60"	29" - 42"	46.89"	35.37"	26.84"	1 1/4"		•	•	5
RTEFD4860	48"	60"	29" - 42"	45.74"	41.37"	31.46"	1 1/4"		•	•	5
RTEFD4872	48"	72"	29" - 42"	57.74"	41.37"	31.46"	1 1/4"		•	•	5
RTEFD6072	60"	72"	29" - 42"	55.61"	53.37"	40.68"	1 1/4"		•	•	5

(model RTEED4260 with caster/glide base shown)

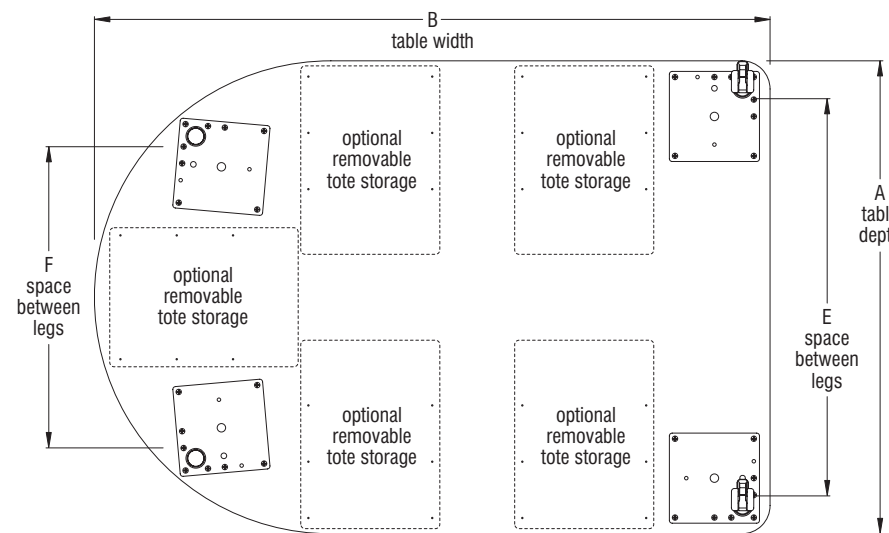

(bottom view)

Note: Table height dimensions in the chart above represent tables with a nominal tabletop thickness of 1 1/4". Reference the "Desk/Table Storage Dimensions" charts on pages 9-12 for storage clearance dimensions.

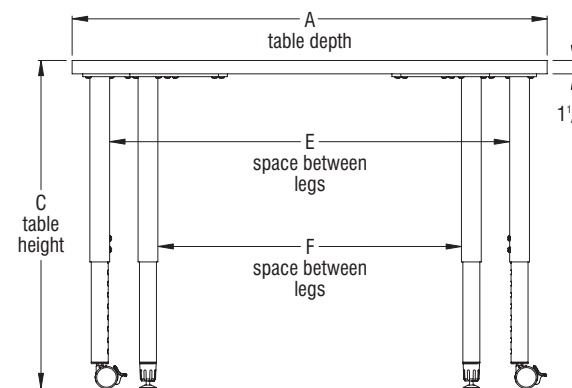

(front view)

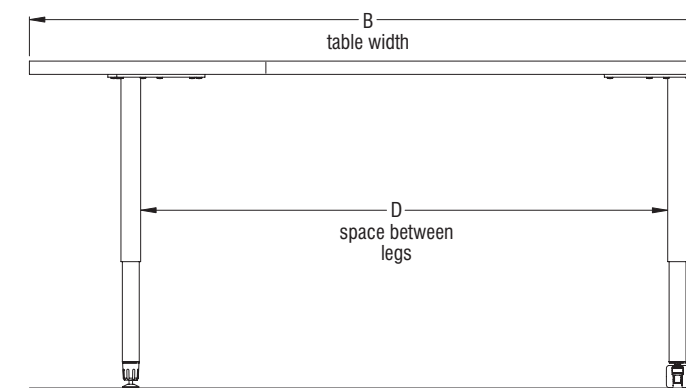

(side view)



DIMENSIONS

Ruckus Kidney Activity Table

Model Number	A Table Depth	B Table Width	C Table Height	D Space Between Legs	E Space Between Legs	F	Worksurface Thickness	Fixed Legs	Adjustable Legs	Removable Tote Storage
RTEHF367220	36"	72"	12" - 19"	29.79"	29.63"	20"	1 1/4"		•	3
RTEHF367224	36"	72"	12" - 19"	29.87"	29.63"	24"	1 1/4"		•	3
RTEHF368430	36"	84"	12" - 19"	30.50"	32.85"	30"	1 1/4"		•	3
RTEHF487220	48"	72"	12" - 19"	36.90"	36.93"	20"	1 1/4"		•	3
RTEHF487224	48"	72"	12" - 19"	36.81"	36.93"	24"	1 1/4"		•	3
RTEHF488430	48"	84"	12" - 19"	37.61"	39.53"	30"	1 1/4"		•	3
RTEAF367220	36"	72"	29"	29.79"	29.63"	20"	1 1/4"	•		3
RTEAF367224	36"	72"	29"	29.87"	29.63"	24"	1 1/4"	•		3
RTEAF368430	36"	84"	29"	30.50"	32.85"	30"	1 1/4"	•		3
RTEAF487220	48"	72"	29"	36.90"	36.93"	20"	1 1/4"	•	•	3
RTEAF487224	48"	72"	29"	36.81"	36.93"	24"	1 1/4"	•	•	3
RTEAF488430	48"	84"	29"	37.61"	39.53"	30"	1 1/4"	•	•	3
RTEEF367220	36"	72"	20" - 33"	29.79"	29.63"	20"	1 1/4"		•	3
RTEEF367224	36"	72"	20" - 33"	29.87"	29.63"	24"	1 1/4"		•	3
RTEEF368430	36"	84"	20" - 33"	30.50"	32.85"	30"	1 1/4"		•	3
RTEEF487220	48"	72"	20" - 33"	36.90"	36.93"	20"	1 1/4"		•	3
RTEEF487224	48"	72"	20" - 33"	36.81"	36.93"	24"	1 1/4"		•	3
RTEEF488430	48"	84"	20" - 33"	37.61"	39.53"	30"	1 1/4"		•	3
RTEFF367220	36"	72"	29" - 42"	29.79"	29.63"	20"	1 1/4"		•	3
RTEFF367224	36"	72"	29" - 42"	29.87"	29.63"	24"	1 1/4"		•	3
RTEFF368430	36"	84"	29" - 42"	30.50"	32.85"	30"	1 1/4"		•	3
RTEFF487220	48"	72"	29" - 42"	36.90"	36.93"	20"	1 1/4"		•	3
RTEFF487224	48"	72"	29" - 42"	36.81"	36.93"	24"	1 1/4"		•	3
RTEFF488430	48"	84"	29" - 42"	37.61"	39.53"	30"	1 1/4"		•	3

(model RTEEF367220 with caster/glide base shown)

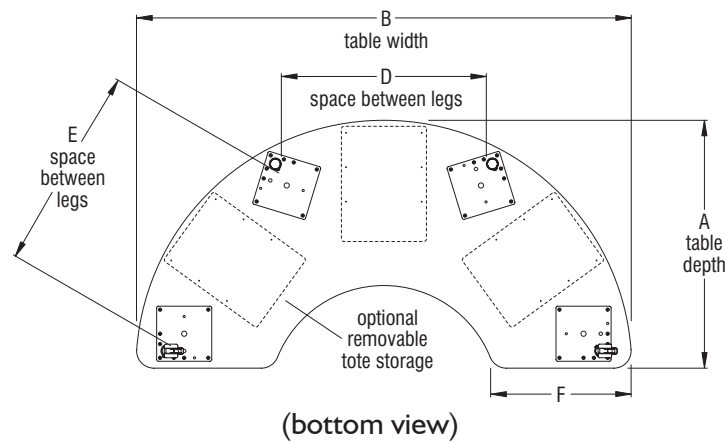

(bottom view)

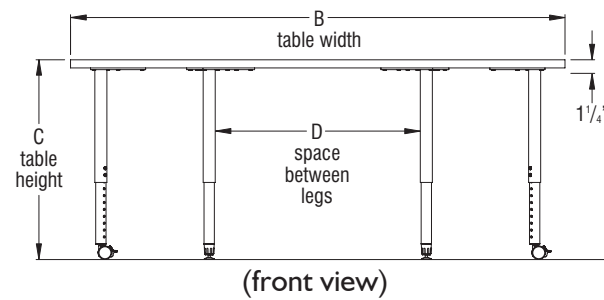

(front view)

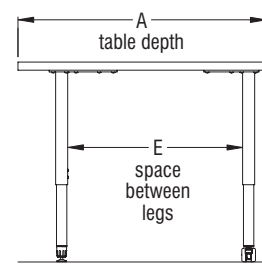

(side view)

Note: Table height dimensions in the chart above represent tables with a nominal tabletop thickness of 1 1/4". Reference the "Desk/Table Storage Dimensions" charts on pages 9-12 for storage clearance dimensions.

DIMENSIONS

Ruckus Sprocket Activity Table - 20"-24"

Model Number	A Table Depth	B Table Width	C Table Height	D Space Between Legs	E Space Between Legs	F	G	Worksurface Thickness	Fixed Legs	Adjustable Legs	Removable Tote Storage
RTEHG20	44.29"	50.37"	12" - 19"	35.64"	NA	31.57"	20"	1 1/4"		•	0
RTEHG24	46"	52.34"	12" - 19"	35.64"	NA	29.57"	24"	1 1/4"		•	3
RTEAG20	44.29"	50.37"	29"	35.64"	NA	31.57"	20"	1 1/4"	•		0
RTEAG24	46"	52.34"	29"	35.64"	NA	29.57"	24"	1 1/4"	•		3
RTEEG20	44.29"	50.37"	20" - 33"	35.64"	NA	31.57"	20"	1 1/4"		•	0
RTEEG24	46"	52.34"	20" - 33"	35.64"	NA	29.57"	24"	1 1/4"		•	3
RTEFG20	44.29"	50.37"	29" - 42"	35.64"	NA	31.57"	20"	1 1/4"		•	0
RTEFG24	46"	52.34"	29" - 42"	35.64"	NA	29.57"	24"	1 1/4"		•	3

(model RTEEG24 with caster/glide base shown)

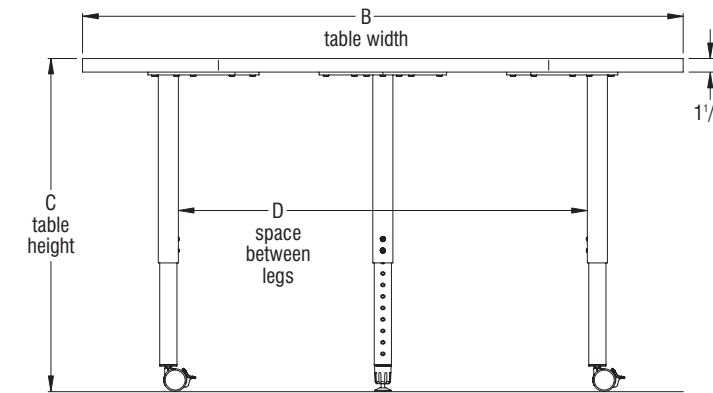

Sprocket Table - 20"-24"
(front view)

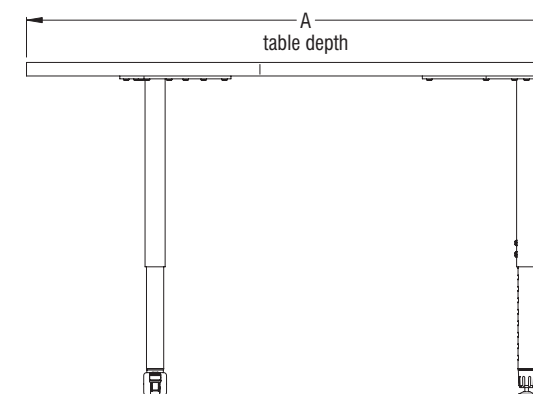

Sprocket Table - 20"-24"
(side view)

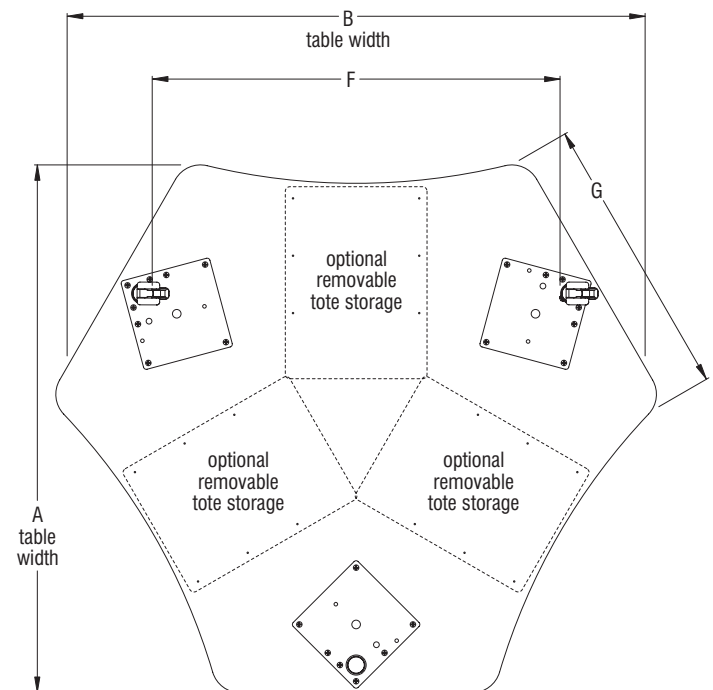

Sprocket Table - 20"-24"
(bottom view)

Note: Table height dimensions in the chart above represent tables with a nominal tabletop thickness of 1 1/4". Reference the "Desk/Table Storage Dimensions" charts on pages 9-12 for storage clearance dimensions.



DIMENSIONS

Ruckus Sprocket Activity Table - 30"

Model Number	A Table Depth	B Table Width	C Table Height	D Space Between Legs	E Space Between Legs	F	G	Worksurface Thickness	Fixed Legs	Adjustable Legs	Removable Tote Storage
RTEAG30	48"	54.65"	29"	22.78"	23.63"	26.22"	30"	1 1/4"	•		0
RTEEG30	48"	54.65"	20" - 33"	22.78"	23.63"	26.22"	30"	1 1/4"		•	0
RTEFG30	48"	54.65"	29" - 42"	22.78"	23.63"	26.22"	30"	1 1/4"		•	0

(model RTEEG30 with caster/glide base shown)

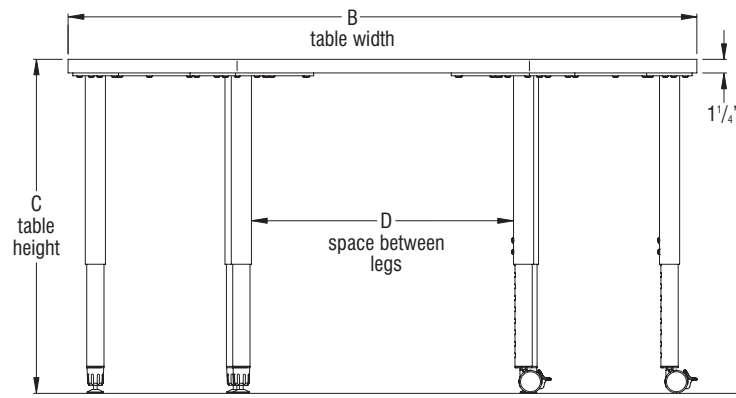

Sprocket Table - 30" (front view)

Note: Table height dimensions in the chart above represent tables with a nominal tabletop thickness of 1 1/4". Reference the "Desk/Table Storage Dimensions" charts on pages 9-12 for storage clearance dimensions.

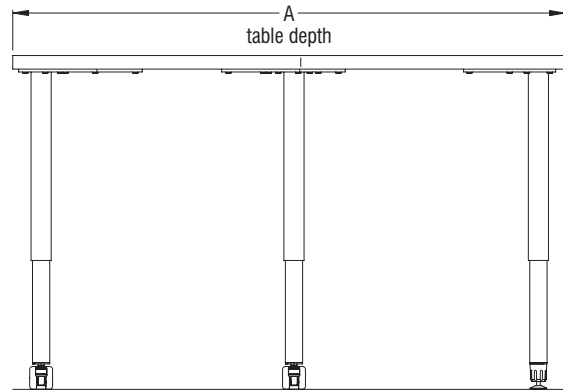

Sprocket Table - 30" (side view)

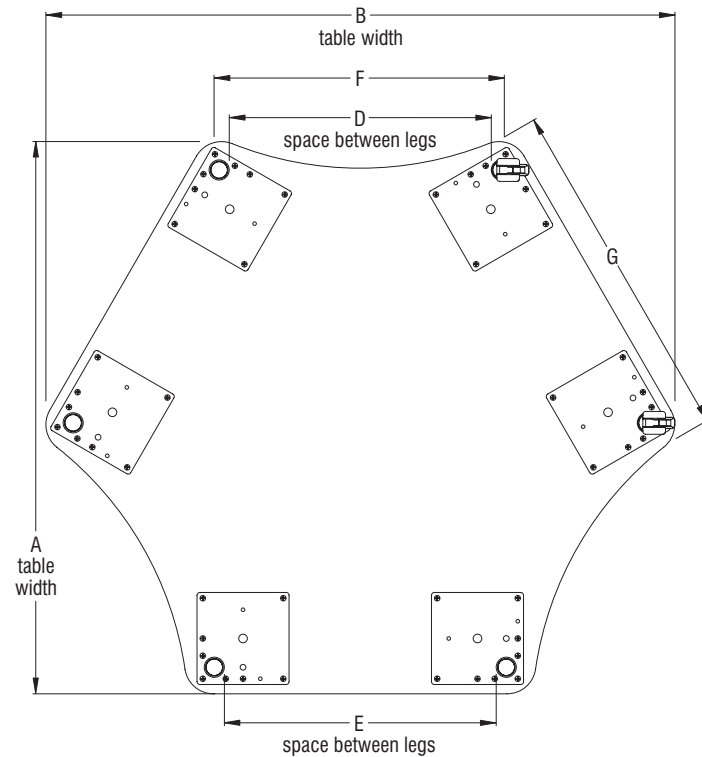

Sprocket Table - 30" (bottom view)

DIMENSIONS

Ruckus Horseshoe Activity Table

Model Number	A Table Depth	B Table Width	C Table Height	D Space Between Legs	E Space Between Legs	F	G	H	Worksurface Thickness	Fixed Legs	Adjustable Legs	Removable Tote Storage
RTEHH487220	48"	72"	12" - 19"	39.60"	35.48"	20"	32"	28"	1 1/4"		•	3
RTEHH488024	48"	80"	12" - 19"	44.53"	35.18"	24"	32"	24"	1 1/4"		•	3
RTEHH489230	48"	92"	12" - 19"	45.73"	38.22"	30"	32"	18"	1 1/4"		•	3
RTEHH606620	60"	66"	12" - 19"	35.91"	47.42"	20"	26"	40"	1 1/4"		•	5
RTEHH607224	60"	72"	12" - 19"	36.78"	48.41"	24"	24"	36"	1 1/4"		•	5
RTEHH608630	60"	86"	12" - 19"	42.54"	50.92"	30"	26"	30"	1 1/4"		•	5
RTEAH487220	48"	72"	29"	39.60"	35.48"	20"	32"	28"	1 1/4"	•		3
RTEAH488024	48"	80"	29"	44.53"	35.18"	24"	32"	24"	1 1/4"	•		3
RTEAH489230	48"	92"	29"	45.73"	38.22"	30"	32"	18"	1 1/4"	•		3
RTEAH606620	60"	66"	29"	35.91"	47.42"	20"	26"	40"	1 1/4"	•		5
RTEAH607224	60"	72"	29"	36.78"	48.41"	24"	24"	36"	1 1/4"	•		5
RTEEH487220	48"	72"	20" - 33"	39.60"	35.48"	20"	32"	28"	1 1/4"		•	3
RTEEH488024	48"	80"	20" - 33"	44.53"	35.18"	24"	32"	24"	1 1/4"		•	3
RTEEH489230	48"	92"	20" - 33"	45.73"	38.22"	30"	32"	18"	1 1/4"		•	3
RTEEH606620	60"	66"	20" - 33"	35.91"	47.42"	20"	26"	40"	1 1/4"		•	5
RTEEH607224	60"	72"	20" - 33"	36.78"	48.41"	24"	24"	36"	1 1/4"		•	5
RTEEH608630	60"	86"	20" - 33"	42.54"	50.92"	30"	26"	30"	1 1/4"		•	5
RTEFH487220	48"	72"	29" - 42"	39.60"	35.48"	20"	32"	28"	1 1/4"		•	3
RTEFH488024	48"	80"	29" - 42"	44.53"	35.18"	24"	32"	24"	1 1/4"		•	3
RTEFH489230	48"	92"	29" - 42"	45.73"	38.22"	30"	32"	18"	1 1/4"		•	3
RTEFH606620	60"	66"	29" - 42"	35.91"	47.42"	20"	26"	40"	1 1/4"		•	5
RTEFH607224	60"	72"	29" - 42"	36.78"	48.41"	24"	24"	36"	1 1/4"		•	5
RTEFH608630	60"	86"	29" - 42"	42.54"	50.92"	30"	26"	30"	1 1/4"		•	5

(model RTEEH487220 with caster/glide base shown)

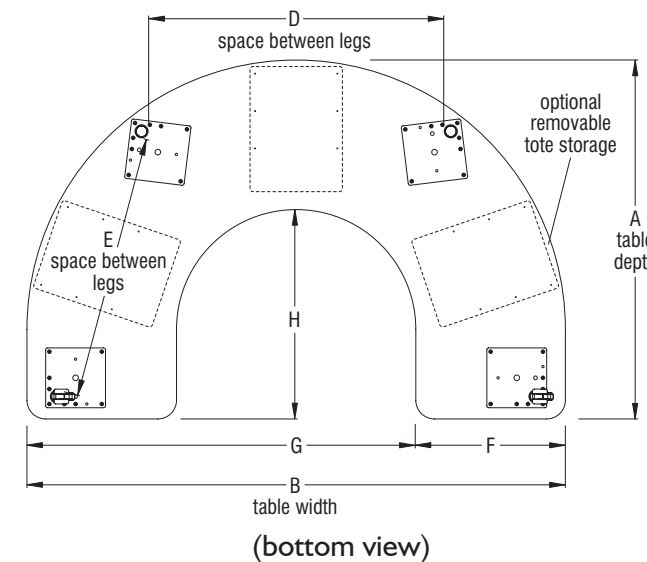

(bottom view)

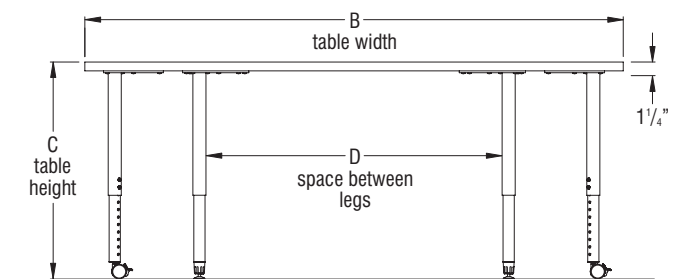

(front view)

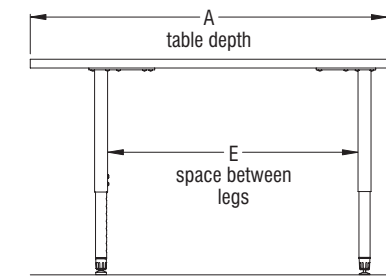

(side view)

Note: Table height dimensions in the chart above represent tables with a nominal tabletop thickness of 1 1/4". Reference the "Desk/Table Storage Dimensions" charts on pages 9-12 for storage clearance dimensions.



DIMENSIONS

Ruckus Clover Activity Table

Model Number	A Table Depth	B Table Width	C Table Height	D Space Between Legs	E Space Between Legs	Worksurface Thickness	Fixed Legs	Adjustable Legs	Removable Tote Storage
RTEHY39	35.34"	35.34"	12" - 19"	22.41"	22.41"	1 1/4"		•	0
RTEHY48	44.34"	44.34"	12" - 19"	28.78"	28.78"	1 1/4"		•	2
RTEAY48	44.34"	44.34"	29"	28.78"	28.78"	1 1/4"	•		2
RTEAY54	50.34"	50.34"	29"	33.02"	33.02"	1 1/4"	•		2
RTEEY39	35.34"	35.34"	20" - 33"	22.41"	22.41"	1 1/4"		•	0
RTEEY48	44.34"	44.34"	20" - 33"	28.78"	28.78"	1 1/4"		•	2
RTEEY54	50.34"	50.34"	20" - 33"	33.02"	33.02"	1 1/4"		•	2
RTEFY48	44.34"	44.34"	29" - 42"	28.78"	28.78"	1 1/4"		•	2
RTEFY54	50.34"	50.34"	29" - 42"	33.02"	33.02"	1 1/4"		•	2

(model RTEHY39 with caster/glide base shown)

Note: Table height dimensions in the chart above represent tables with a nominal tabletop thickness of 1 1/4". Reference the "Desk/Table Storage Dimensions" charts on pages 9-12 for storage clearance dimensions.

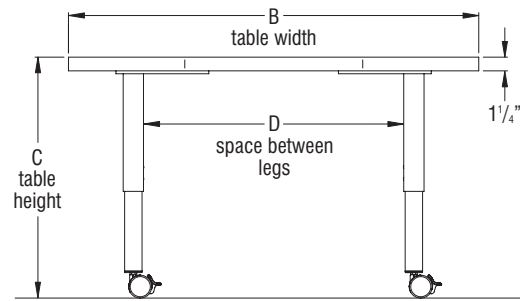

(front view)

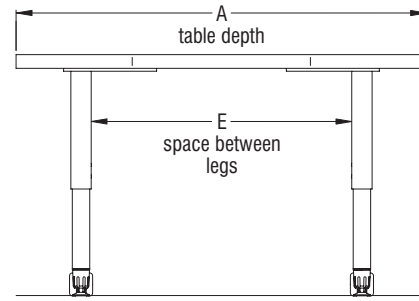

(side view)

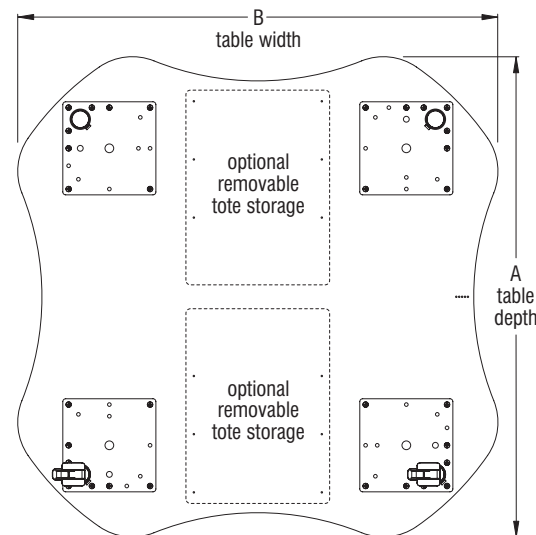

(bottom view)

DIMENSIONS

Ruckus Trapezoid Activity Table

Model Number	A Table Depth	B Table Width	C Table Height	D Space Between Legs	E Space Between Legs	F Space Between Legs	Worksurface Thickness	Fixed Legs	Adjustable Legs	Removable Tote Storage
RTEAM2448	24"	48"	29"	19.36"	37.59"	14.04"	1 1/4"	•		1
RTEAM3060	30"	60"	29"	25.36"	49.59"	19.23"	1 1/4"	•		2
RTEHM2448	24"	48"	13.75" - 20.75"	19.36"	37.59"	14.04"	1 1/4"		•	1
RTEHM3060	30"	60"	13.75" - 20.75"	25.36"	49.59"	19.23"	1 1/4"		•	2
RTEEM2448	24"	48"	20" - 33"	19.36"	37.59"	14.04"	1 1/4"		•	1
RTEEM3060	30"	60"	20" - 33"	25.36"	49.59"	19.23"	1 1/4"		•	2
RTEFM2448	24"	48"	29" - 42"	19.36"	37.59"	14.04"	1 1/4"		•	1
RTEFM3060	30"	60"	29" - 42"	25.36"	49.59"	19.23"	1 1/4"		•	2

(model RTEEM3060 with caster/glide base shown)

Note: Table height dimensions in the chart above represent tables with a nominal tabletop thickness of 1 1/4". Reference the "Desk/Table Storage Dimensions" charts on pages 9-12 for storage clearance dimensions.

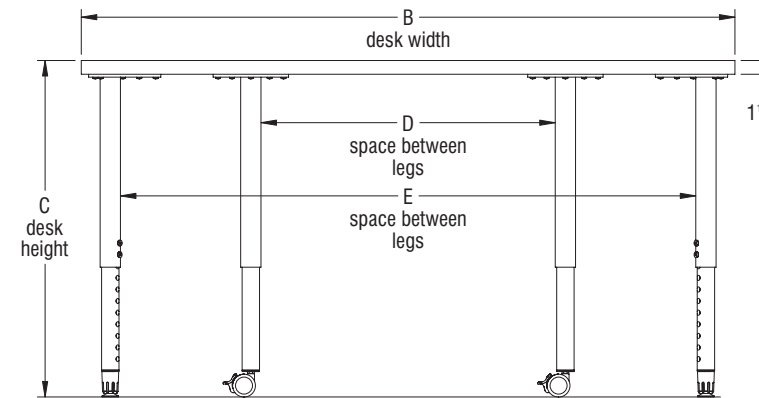

(front view)

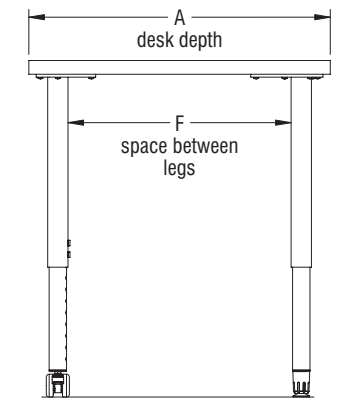

(side view)

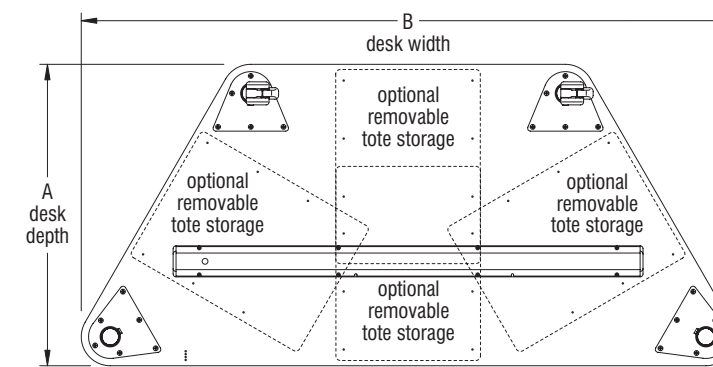

(bottom view)



DIMENSIONS

Ruckus Yin-Yang Activity Table

Model Number	A Table Depth	B Table Width	C Table Height	D Space Between Legs	E Space Between Legs	F Space Between Legs	G Space Between Legs	Worksurface Thickness	Fixed Legs	Adjustable Legs	Removable Tote Storage
RTEAO54	30"	54"	29"	25.47"	46.83"	14.18"	17.82"	1 1/4"	•		1
RTEAO60	33"	60"	29"	25.75"	52.96"	18.47"	20.32"	1 1/4"	•		2
RTEHO54	30"	54"	13.75" - 20.75"	25.47"	46.83"	14.18"	17.82"	1 1/4"		•	1
RTEHO60	33"	60"	13.75" - 20.75"	25.75"	52.96"	18.47"	20.32"	1 1/4"		•	2
RTEEO54	30"	54"	20" - 33"	25.47"	46.83"	14.18"	17.82"	1 1/4"		•	1
RTEEO60	33"	60"	20" - 33"	25.75"	52.96"	18.47"	20.32"	1 1/4"		•	2
RTEFO54	30"	54"	29" - 42"	25.47"	46.83"	14.18"	17.82"	1 1/4"		•	1
RTEFO60	33"	60"	29" - 42"	25.75"	52.96"	18.47"	20.32"	1 1/4"		•	2

(model RTEEO60 with caster/glide base shown)

Note: Table height dimensions in the chart above represent tables with a nominal tabletop thickness of 1 1/4". Reference the "Desk/Table Storage Dimensions" charts on pages 9-12 for storage clearance dimensions.

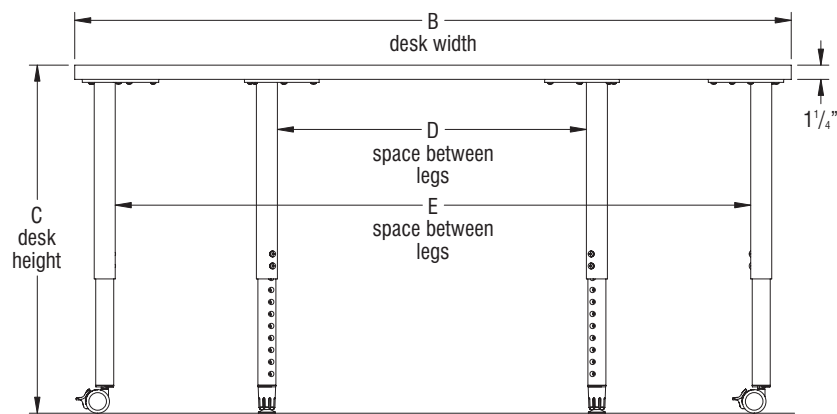

(front view)

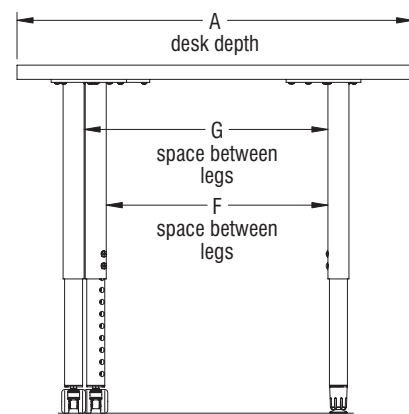

(side view)

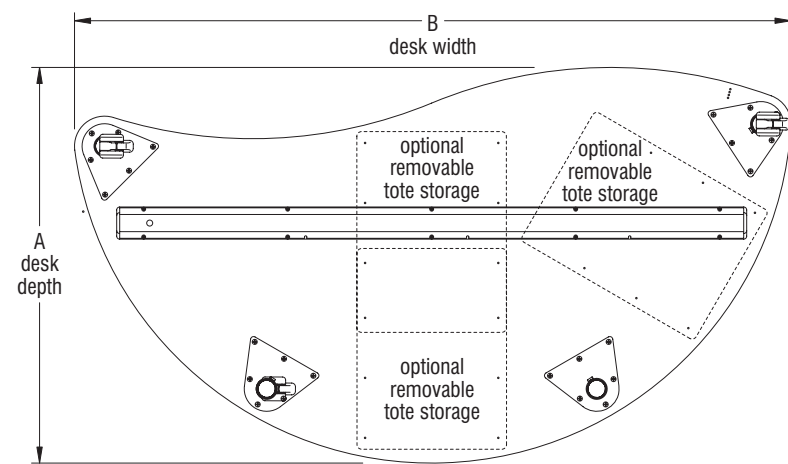

(bottom view)

DIMENSIONS

Ruckus Half-Round Activity Table - 48"

Model Number	A Table Depth	B Table Width	C Table Height	D Space Between Legs	E Space Between Legs	Worksurface Thickness	Fixed Legs	Adjustable Legs	Removable Tote Storage
RTEAQ48	24"	48"	29"	19.66"	41.08"	1 1/4"	•		2
RTEHQ48	24"	48"	13.75" - 20.75"	19.66"	41.08"	1 1/4"		•	2
RTEEQ48	24"	48"	20" - 33"	19.66"	41.08"	1 1/4"		•	2
RTEFQ48	24"	48"	29" - 42"	19.66"	41.08"	1 1/4"		•	2

(model RTEEQ48 with caster/glide base shown)

Note: Table height dimensions in the chart above represent tables with a nominal tabletop thickness of 1 1/4". Reference the "Desk/Table Storage Dimensions" charts on pages 9-12 for storage clearance dimensions.

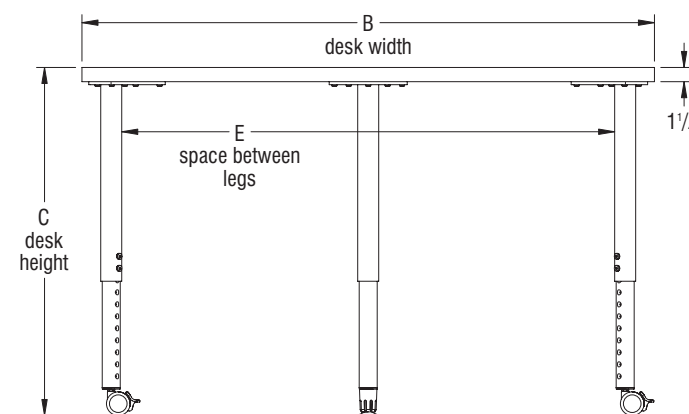

(front view)

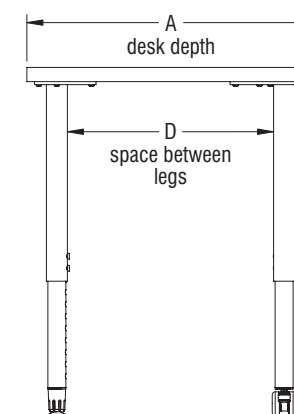

(side view)

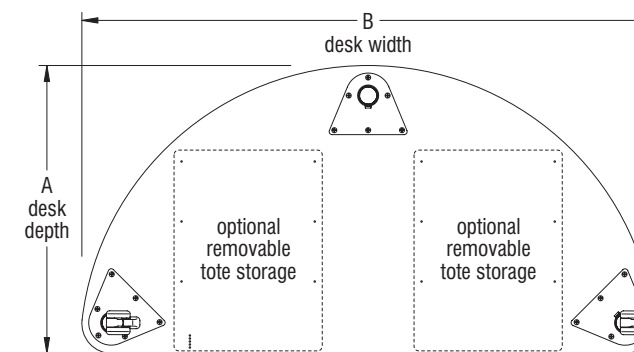

(bottom view)



DIMENSIONS

Ruckus Half-Round Activity Table - 60"

Model Number	A Table Depth	B Table Width	C Table Height	D Space Between Legs	E Space Between Legs	F Space Between Legs	Worksurface Thickness	Fixed Legs	Adjustable Legs	Removable Tote Storage
RTEAQ60	30"	60"	29"	27.40"	53.12"	11.11"	1 1/4"	•		3
RTEHQ60	30"	60"	13.75" - 20.75"	27.40"	53.12"	11.11"	1 1/4"		•	3
RTEEQ60	30"	60"	20" - 33"	27.40"	53.12"	11.11"	1 1/4"		•	3
RTEFQ60	30"	60"	29" - 42"	27.40"	53.12"	11.11"	1 1/4"		•	3

(model RTEEQ60 with caster/glide base shown)

Note: Table height dimensions in the chart above represent tables with a nominal tabletop thickness of 1 1/4". Reference the "Desk/Table Storage Dimensions" charts on pages 9-12 for storage clearance dimensions.

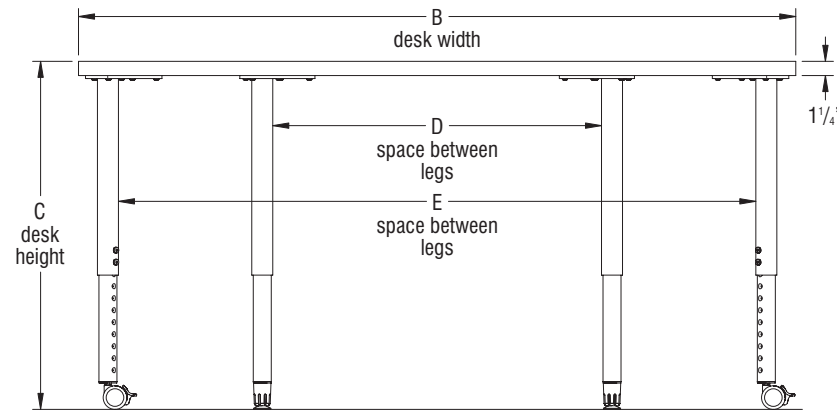

(front view)

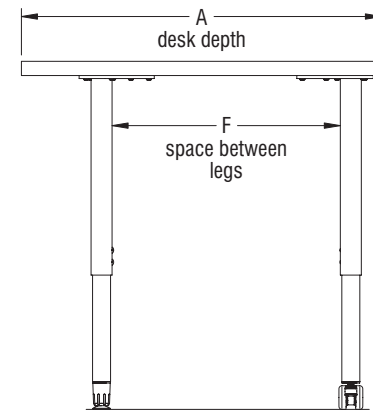

(side view)

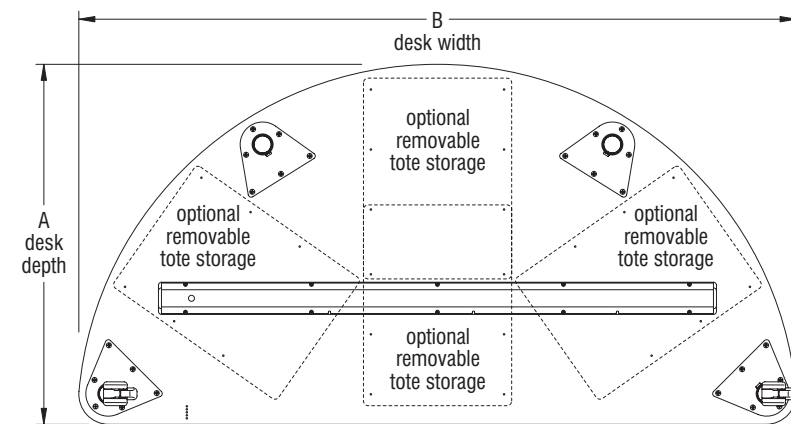

(bottom view)

DIMENSIONS

Ruckus Arc Activity Table

Model Number	A Table Depth	B Table Width	C Table Height	D Space Between Legs	E Space Between Legs	F Space Between Legs	Worksurface Thickness	Fixed Legs	Adjustable Legs	Removable Tote Storage
RTEAR24	26.53"	58.75"	29"	42.43"	52.38"	16.83"	1 1/4"	•		2
RTEHR24	26.53"	58.75"	13.75" - 20.75"	42.43"	52.38"	16.83"	1 1/4"		•	2
RTEER24	26.53"	58.75"	20" - 33"	42.43"	52.38"	16.83"	1 1/4"		•	2
RTEFR24	26.53"	58.75"	29" - 42"	42.43"	52.38"	16.83"	1 1/4"		•	2

(model RTEER24 with caster/glide base shown)

Note: Table height dimensions in the chart above represent tables with a nominal tabletop thickness of 1 1/4". Reference the "Desk/Table Storage Dimensions" charts on pages 9-12 for storage clearance dimensions.

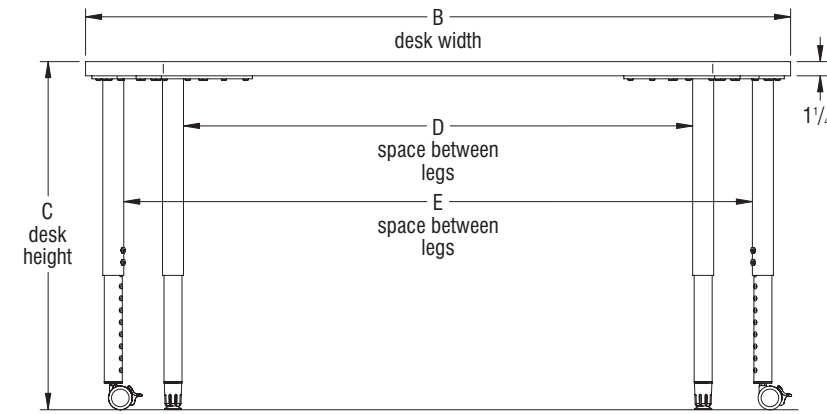

(front view)

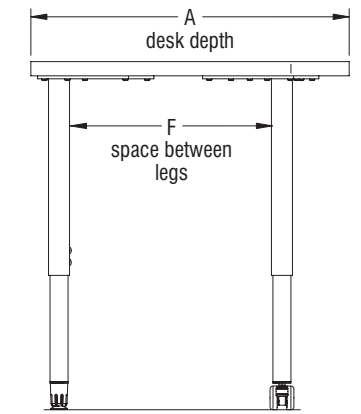

(side view)

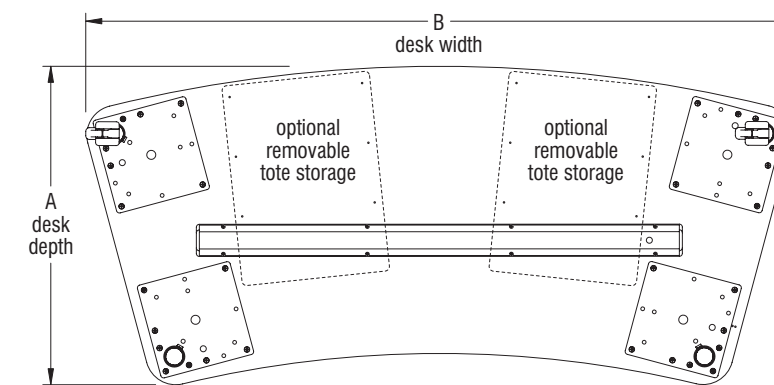

(bottom view)



DIMENSIONS

Ruckus Crescent Activity Table

Model Number	A Table Diameter	B Table Height	C Space Between Legs	Worksurface Thickness	Fixed Legs	Adjustable Legs	Removable Tote Storage
RTEAT48	48"	29"	24.89"	1 1/4"	•		3
RTEHT48	48"	13.75" - 20.75"	24.89"	1 1/4"		•	3
RTEET48	48"	20" - 33"	24.89"	1 1/4"		•	3
RTEFT48	48"	29" - 42"	24.89"	1 1/4"		•	3

(model RTEET48 with caster/glide base shown)

Note: Table height dimensions in the chart above represent tables with a nominal tabletop thickness of 1 1/4". Reference the "Desk/Table Storage Dimensions" charts on pages 9-12 for storage clearance dimensions.

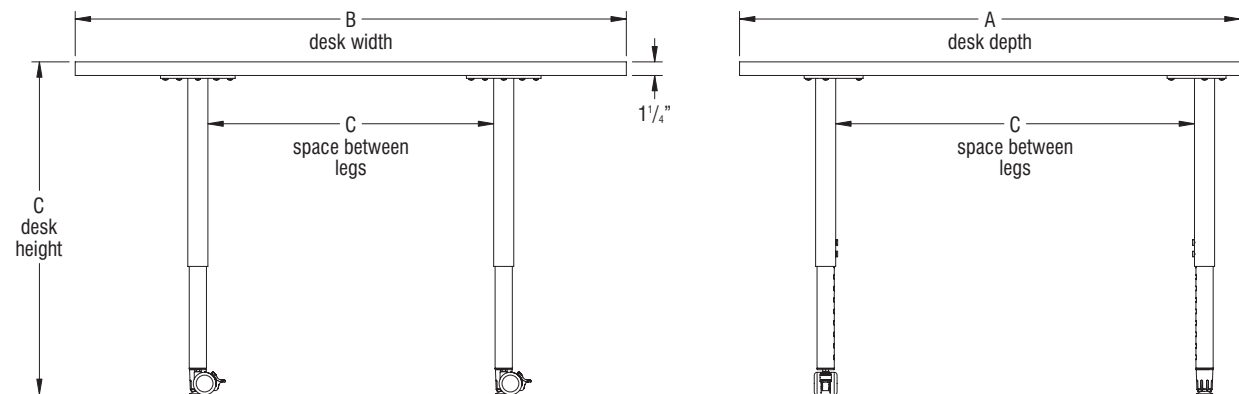

(front view)

(side view)

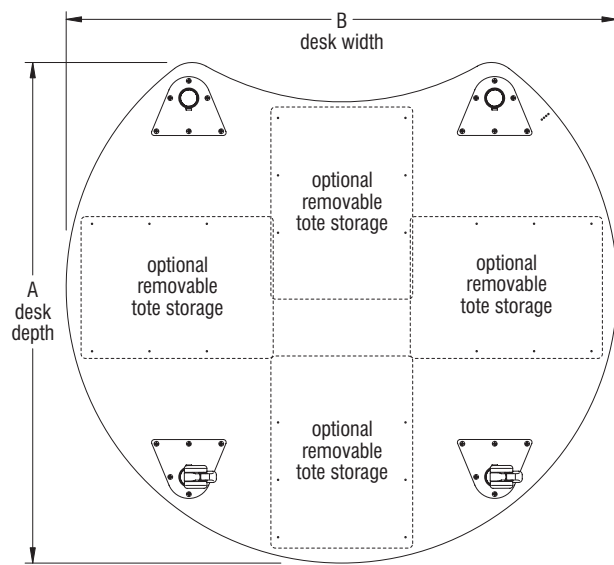

(bottom view)

DIMENSIONS

Ruckus Amoeba Activity Table

Model Number	A Table Depth	B Table Width	C Table Height	D Space Between Legs	E Space Between Legs	F Space Between Legs	Worksurface Thickness	Fixed Legs	Adjustable Legs	Removable Tote Storage
RTEAU3648	36"	48"	29"	20.33"	39.76"	20.33"	1 1/4"	•		1
RTEAU4365	43"	65"	29"	24.11"	56.64"	30.78"	1 1/4"	•		2
RTEHU3648	36"	48"	13.75" - 20.75"	20.33"	39.76"	20.33"	1 1/4"		•	1
RTEHU4365	43"	65"	13.75" - 20.75"	24.11"	56.64"	30.78"	1 1/4"		•	2
RTEEU3648	36"	48"	20" - 33"	20.33"	39.76"	20.33"	1 1/4"		•	1
RTEEU4365	43"	65"	20" - 33"	24.11"	56.64"	30.78"	1 1/4"		•	2
RTEFU3648	36"	48"	29" - 42"	20.33"	39.76"	20.33"	1 1/4"		•	1
RTEFU4365	43"	65"	29" - 42"	24.11"	56.64"	30.78"	1 1/4"		•	2

(model RTEHU3648 with caster/glide base shown)

Note: Table height dimensions in the chart above represent tables with a nominal tabletop thickness of 1 1/4". Reference the "Desk/Table Storage Dimensions" charts on pages 9-12 for storage clearance dimensions.

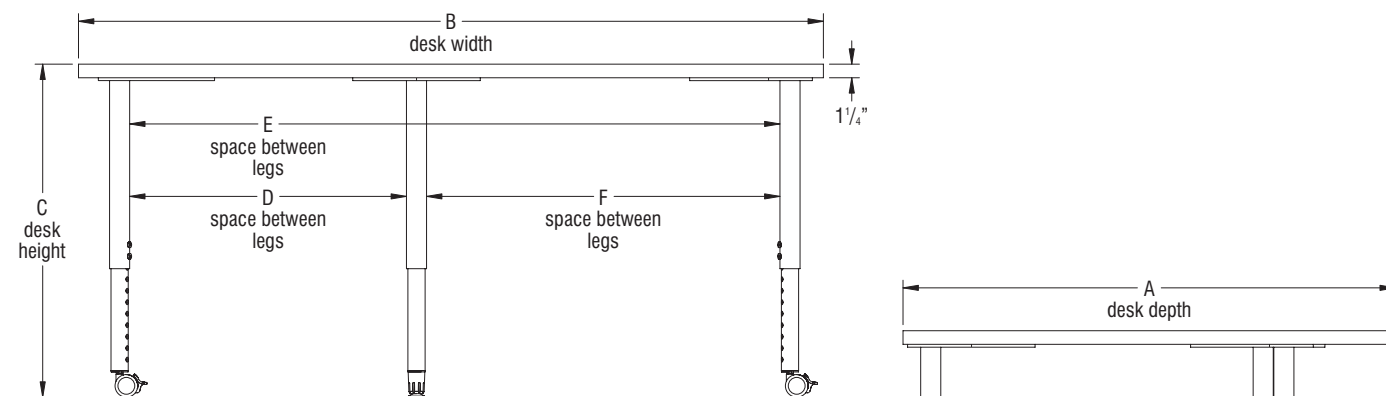

(front view)

(side view)

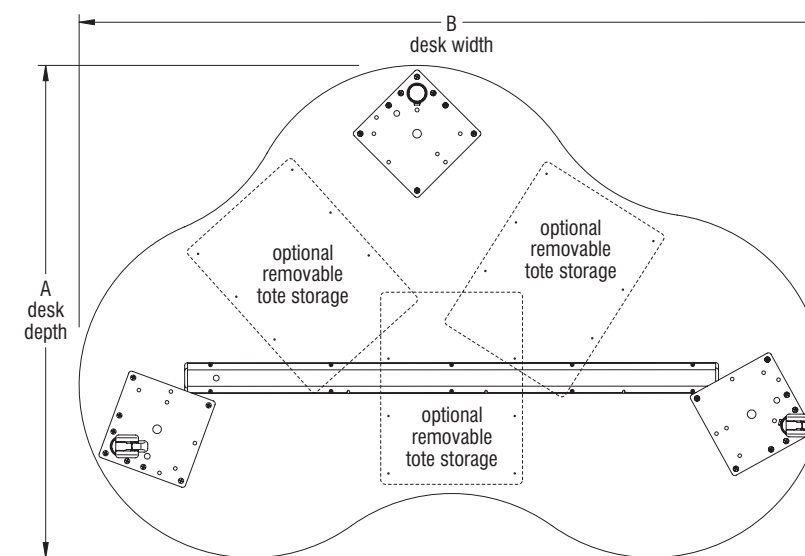

(bottom view)



DIMENSIONS

Ruckus Wave Activity Table

Model Number	A Table Depth	B Table Width	C Table Height	D Space Between Legs	E Space Between Legs	Worksurface Thickness	Fixed Legs	Adjustable Legs	Removable Tote Storage
RTEAW3054	34.68"	54"	29"	22.12"	48.13"	1 1/4"	•		2
RTEAW3060	35.86"	60"	29"	21.77"	54.13"	1 1/4"	•		2
RTEHW3054	34.68"	54"	13.75" - 20.75"	22.12"	48.13"	1 1/4"		•	2
RTEHW3060	35.86"	60"	13.75" - 20.75"	21.77"	54.13"	1 1/4"		•	2
RTEEW3054	34.68"	54"	20" - 33"	22.12"	48.13"	1 1/4"		•	2
RTEEW3060	35.86"	60"	20" - 33"	21.77"	54.13"	1 1/4"		•	2
RTEFW3054	34.68"	54"	29" - 42"	22.12"	48.13"	1 1/4"		•	2
RTEFW3060	35.86"	60"	29" - 42"	21.77"	54.13"	1 1/4"		•	2

(model RTEEW3054 with caster/glide base shown)

Note: Table height dimensions in the chart above represent tables with a nominal tabletop thickness of 1 1/4". Reference the "Desk/Table Storage Dimensions" charts on pages 9-12 for storage clearance dimensions.

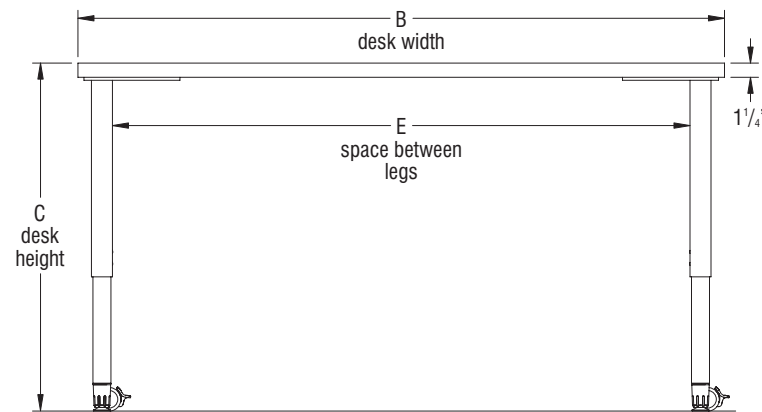

(front view)

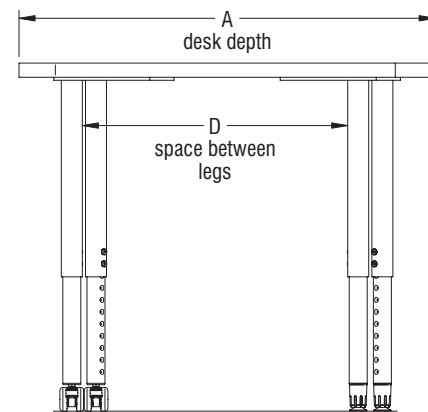

(side view)

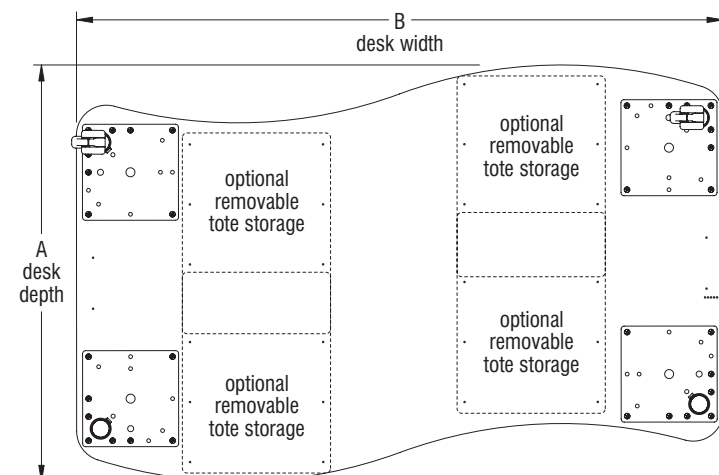

(bottom view)

DIMENSIONS

Ruckus Quarter-Round Activity Table

Model Number	A Table Depth	B Table Width	C Table Height	D Space Between Legs	E Space Between Legs	F Space Between Legs	Worksurface Thickness	Fixed Legs	Adjustable Legs	Removable Tote Storage
RTEAX24	24"	42.9"	29"	17.05"	22.88"	25.09"	1 1/4"	•		0
RTEHX24	24"	42.9"	13.75" - 20.75"	17.05"	22.88"	25.09"	1 1/4"		•	0
RTEEX24	24"	42.9"	20" - 33"	17.05"	22.88"	25.09"	1 1/4"		•	0
RTEFX24	24"	42.9"	29" - 42"	17.05"	22.88"	25.09"	1 1/4"		•	0

(model RTEEX24 with caster/glide base shown)

Note: Table height dimensions in the chart above represent tables with a nominal tabletop thickness of 1 1/4". Reference the "Desk/Table Storage Dimensions" charts on pages 9-12 for storage clearance dimensions.

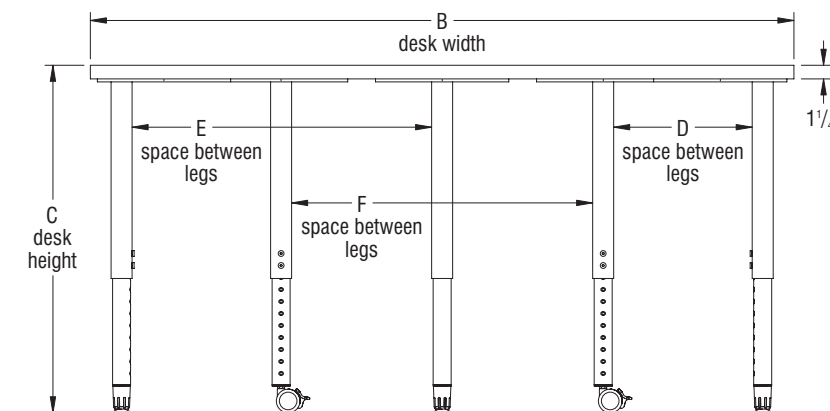

(front view)

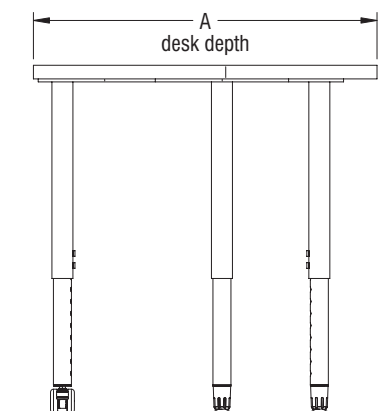

(side view)

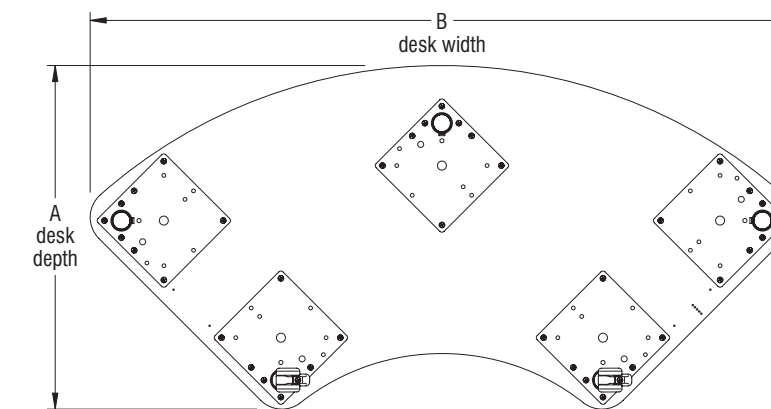

(bottom view)



STATEMENT OF LINE

Ruckus Diamond Activity Table

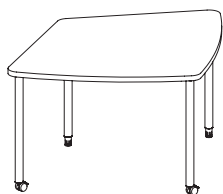

Fixed-Height
 RTEAE30
 RTEAE36

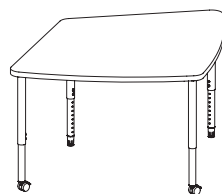

Sit Height Adjustable
 RTEEE30
 RTEEE36

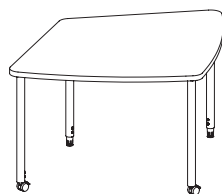

Sit-Stand Height Adjustable
 RTEFE30
 RTEFE36

Ruckus Kite Activity Table

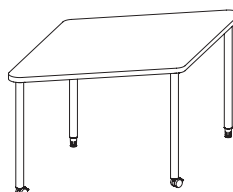

Fixed-Height
 RTEAJ34
 RTEAJ39

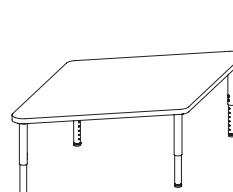

Floor Height Adjustable
 RTEHJ34
 RTEHJ39

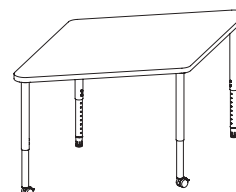

Sit Height Adjustable
 RTEEJ34
 RTEEJ39

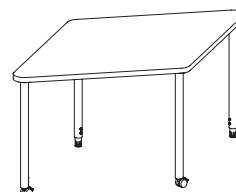

Sit-Stand Height Adjustable
 RTEFJ34
 RTEFJ39

Ruckus Rectangular Activity Table with Rounded Corners

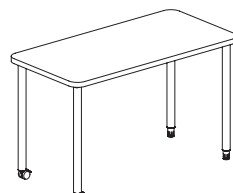

Fixed-Height

- | | | | |
|-----------|-----------|-----------|-----------|
| RTEAA2048 | RTEAA2430 | RTEAA3048 | RTEAA4260 |
| RTEAA2054 | RTEAA2436 | RTEAA3054 | RTEAA4266 |
| RTEAA2060 | RTEAA2448 | RTEAA3060 | RTEAA4272 |
| RTEAA2066 | RTEAA2454 | RTEAA3066 | RTEAA4460 |
| RTEAA2072 | RTEAA2460 | RTEAA3072 | RTEAA4466 |
| | RTEAA2466 | RTEAA3654 | RTEAA4472 |
| | RTEAA2472 | RTEAA3660 | RTEAA4860 |
| | | RTEAA3666 | RTEAA4866 |
| | | RTEAA3672 | RTEAA4872 |

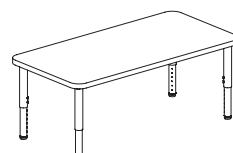

Floor Height Adjustable

- | | | | |
|-----------|-----------|-----------|-----------|
| RTEHA2048 | RTEHA2436 | RTEHA3042 | RTEHA3654 |
| RTEHA2054 | RTEHA2448 | RTEHA3048 | RTEHA3660 |
| RTEHA2060 | RTEHA2454 | RTEHA3054 | RTEHA3666 |
| RTEHA2066 | RTEHA2460 | RTEHA3060 | RTEHA3672 |
| RTEHA2072 | RTEHA2466 | RTEHA3066 | |
| | RTEHA2472 | RTEHA3072 | |

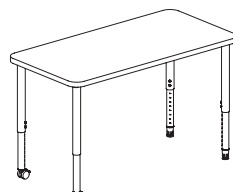

Sit Height Adjustable

- | | | | |
|-----------|-----------|-----------|-----------|
| RTEEA2048 | RTEEA2430 | RTEEA3048 | RTEEA4260 |
| RTEEA2054 | RTEEA2436 | RTEEA3054 | RTEEA4266 |
| RTEEA2060 | RTEEA2448 | RTEEA3060 | RTEEA4272 |
| RTEEA2066 | RTEEA2454 | RTEEA3066 | RTEEA4460 |
| RTEEA2072 | RTEEA2460 | RTEEA3072 | RTEEA4466 |
| | RTEEA2466 | RTEEA3654 | RTEEA4472 |
| | RTEEA2472 | RTEEA3660 | RTEEA4860 |
| | | RTEEA3666 | RTEEA4866 |
| | | RTEEA3672 | RTEEA4872 |

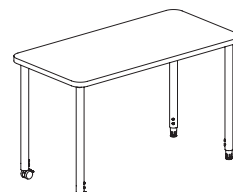

Sit-Stand Height Adjustable

- | | | | |
|-----------|-----------|-----------|-----------|
| RTEFA2048 | RTEFA2430 | RTEFA3048 | RTEFA4260 |
| RTEFA2054 | RTEFA2436 | RTEFA3054 | RTEFA4266 |
| RTEFA2060 | RTEFA2448 | RTEFA3060 | RTEFA4272 |
| RTEFA2066 | RTEFA2454 | RTEFA3066 | RTEFA4460 |
| RTEFA2072 | RTEFA2460 | RTEFA3072 | RTEFA4466 |
| | RTEFA2466 | RTEFA3654 | RTEFA4472 |
| | RTEFA2472 | RTEFA3660 | RTEFA4860 |
| | | RTEFA3666 | RTEFA4866 |
| | | RTEFA3672 | RTEFA4872 |

STATEMENT OF LINE

Ruckus Rectangular Activity Table with Square Corners

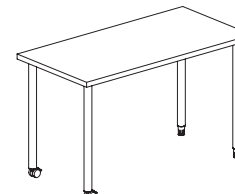

Fixed-Height

- | | | | |
|-----------|-----------|-----------|-----------|
| RXEEA2048 | RXEEA2430 | RXEEA3048 | RXEEA4260 |
| RXEEA2054 | RXEEA2436 | RXEEA3054 | RXEEA4266 |
| RXEEA2060 | RXEEA2448 | RXEEA3060 | RXEEA4272 |
| RXEEA2066 | RXEEA2454 | RXEEA3066 | RXEEA4460 |
| RXEEA2072 | RXEEA2460 | RXEEA3072 | RXEEA4466 |
| | RXEEA2466 | RXEEA3654 | RXEEA4472 |
| | RXEEA2472 | RXEEA3660 | RXEEA4860 |
| | | RXEEA3666 | RXEEA4866 |
| | | RXEEA3672 | RXEEA4872 |

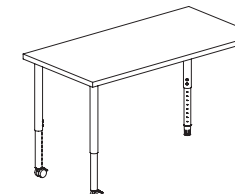

Sit Height Adjustable

- | | | | |
|-----------|-----------|-----------|-----------|
| RXEEA2048 | RXEEA2430 | RXEEA3048 | RXEEA4260 |
| RXEEA2054 | RXEEA2436 | RXEEA3054 | RXEEA4266 |
| RXEEA2060 | RXEEA2448 | RXEEA3060 | RXEEA4272 |
| RXEEA2066 | RXEEA2454 | RXEEA3066 | RXEEA4460 |
| RXEEA2072 | RXEEA2460 | RXEEA3072 | RXEEA4466 |
| | RXEEA2466 | RXEEA3654 | RXEEA4472 |
| | RXEEA2472 | RXEEA3660 | RXEEA4860 |
| | | RXEEA3666 | RXEEA4866 |
| | | RXEEA3672 | RXEEA4872 |

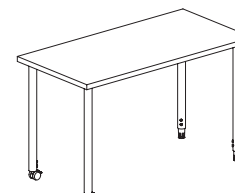

Sit-Stand Height Adjustable

- | | | | |
|-----------|-----------|-----------|-----------|
| RXEFA2048 | RXEFA2430 | RXEFA3048 | RXEFA4260 |
| RXEFA2054 | RXEFA2436 | RXEFA3054 | RXEFA4266 |
| RXEFA2060 | RXEFA2448 | RXEFA3060 | RXEFA4272 |
| RXEFA2066 | RXEFA2454 | RXEFA3066 | RXEFA4460 |
| RXEFA2072 | RXEFA2460 | RXEFA3072 | RXEFA4466 |
| | RXEFA2466 | RXEFA3654 | RXEFA4472 |
| | RXEFA2472 | RXEFA3660 | RXEFA4860 |
| | | RXEFA3666 | RXEFA4866 |
| | | RXEFA3672 | RXEFA4872 |

Ruckus Round Activity Table



Fixed-Height

- RTEAB36
 RTEAB42
 RTEAB48
 RTEAB60



Floor Height Adjustable

- RTEHB36
 RTEHB42
 RTEHB48
 RTEHB60

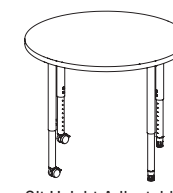

Sit Height Adjustable

- RTEEB36
 RTEEB42
 RTEEB48
 RTEEB60



Sit-Stand Height Adjustable

- RTEFB36
 RTEFB42
 RTEFB48
 RTEFB60



STATEMENT OF LINE

Ruckus Square Activity Table

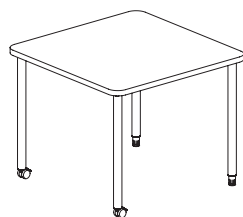

Fixed-Height

RTEAC30
RTEAC36
RTEAC42
RTEAC48

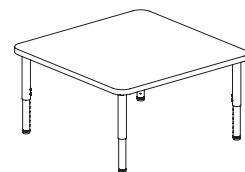

Floor Height Adjustable

RTEHC30
RTEHC36
RTEHC42
RTEHC48

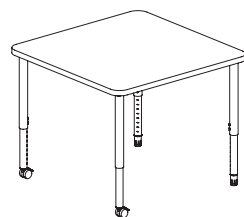

Sit Height Adjustable

RTEEC30
RTEEC36
RTEEC42
RTEEC48

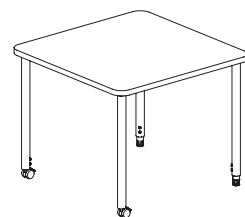

Sit-Stand Height Adjustable

RTEFC30
RTEFC36
RTEFC42
RTEFC48

Ruckus D-Shaped Activity Table

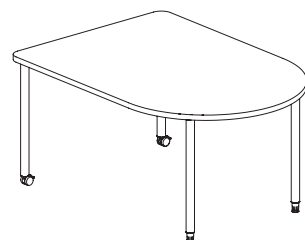

Fixed-Height

RTEAD4260
RTEAD4860
RTEAD4872
RTEAD6072

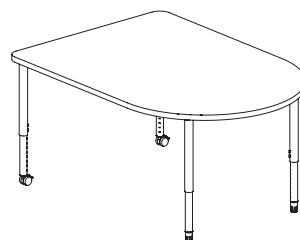

Sit Height Adjustable

RTEED4260
RTEED4860
RTEED4872
RTEED6072

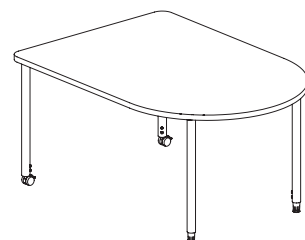

Sit-Stand Height Adjustable

RTEFD4260
RTEFD4860
RTEFD4872
RTEFD6072

Ruckus Kidney Activity Table

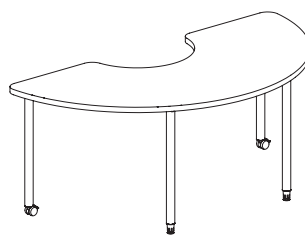

Fixed-Height

RTEAF367220
RTEAF367224
RTEAF368430
RTEAF487220
RTEAF487224
RTEAF488430

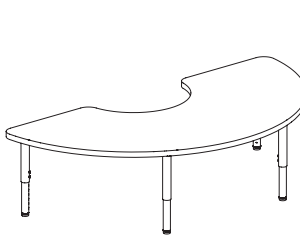

Floor Height Adjustable

RTEHF367220
RTEHF367224
RTEHF368430
RTEHF487220
RTEHF487224
RTEHF488430

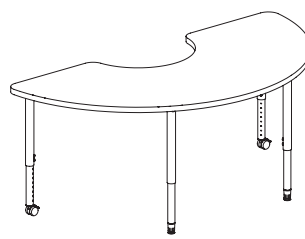

Sit Height Adjustable

RTEEF367220
RTEEF367224
RTEEF368430
RTEEF487220
RTEEF487224
RTEEF488430

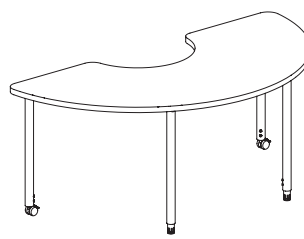

Sit-Stand Height Adjustable

RTEFF367220
RTEFF367224
RTEFF368430
RTEFF487220
RTEFF487224
RTEFF488430

STATEMENT OF LINE

Ruckus Sprocket Activity Table

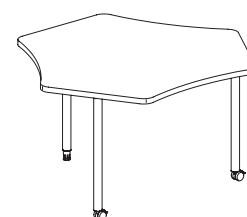

Fixed-Height

RTEAG20
RTEAG24

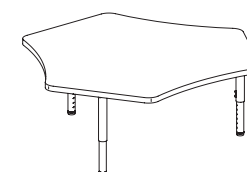

Floor Height Adjustable

RTEHG20
RTEHG24

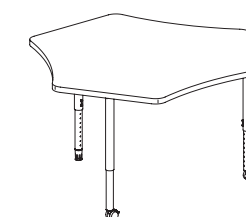

Sit Height Adjustable

RTEEG20
RTEEG24

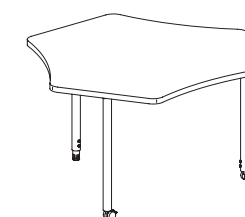

Sit-Stand Height Adjustable

RTEFG20
RTEFG24

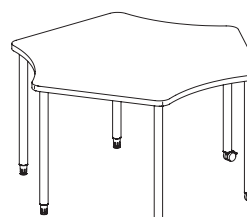

Fixed-Height

RTEAG30

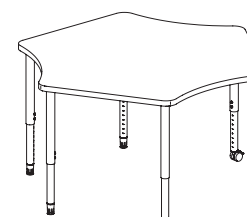

Sit Height Adjustable

RTEEG30

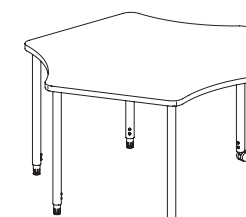

Sit-Stand Height Adjustable

RTEFG30

Ruckus Horseshoe Activity Table

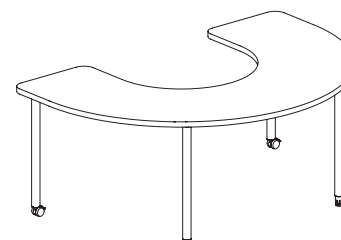

Fixed-Height

RTEAH487220
RTEAH488024
RTEAH489230
RTEAH606620
RTEAH607224
RTEAH608630

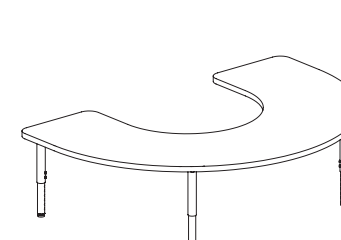

Floor Height Adjustable

RTEHH487220
RTEHH488024
RTEHH489230
RTEHH606620
RTEHH607224
RTEHH608630

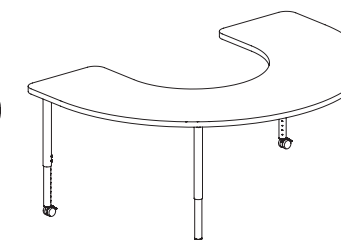

Sit Height Adjustable

RTEEH487220
RTEEH488024
RTEEH489230
RTEEH606620
RTEEH607224
RTEEH608630

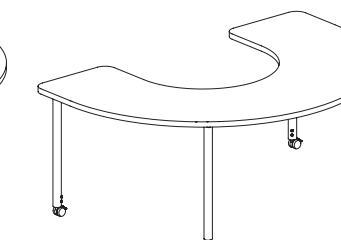

Sit-Stand Height Adjustable

RTEFH487220
RTEFH488024
RTEFH489230
RTEFH606620
RTEFH607224
RTEFH608630

Ruckus Clover Activity Table

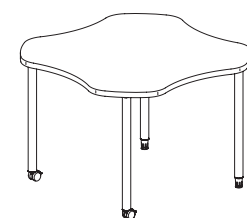

Fixed-Height

RTEAY48
RTEAY54

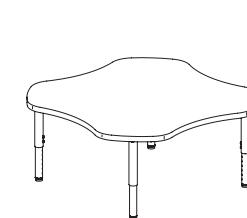

Floor Height Adjustable

RTEHY48
RTEHY54

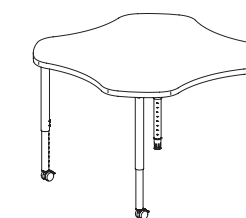

Sit Height Adjustable

RTEEY39
RTEEY48
RTEEY54

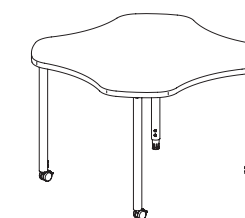

Sit-Stand Height Adjustable

RTEFY48
RTEFY54



STATEMENT OF LINE

Ruckus Trapezoid Activity Table

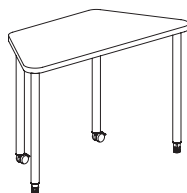

Fixed-Height
RTEAM2448
RTEAM3060

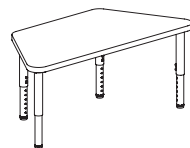

Floor Height Adjustable
RTEHM2448
RTEHM3060

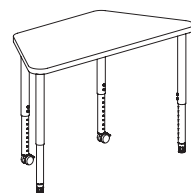

Sit Height Adjustable
RTEEM2448
RTEEM3060

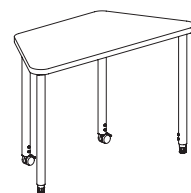

Sit-Stand Height Adjustable
RTEFM2448
RTEFM3060

Ruckus Yin-Yang Activity Table

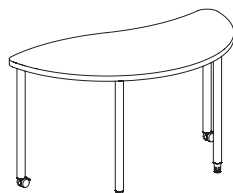

Fixed-Height
RTEA054
RTEA060

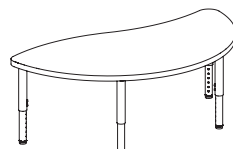

Floor Height Adjustable
RTEH054
RTEH060

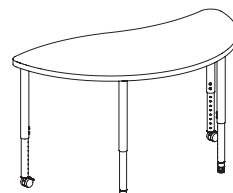

Sit Height Adjustable
RTEE054
RTEE060

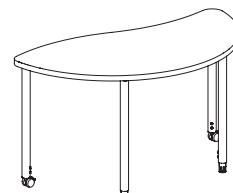

Sit-Stand Height Adjustable
RTEF054
RTEF060

Ruckus Half-Round Activity Table



Fixed-Height
RTEAQ48

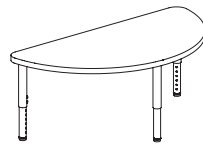

Floor Height Adjustable
RTEHQ48



Sit Height Adjustable
RTEEQ48



Sit-Stand Height Adjustable
RTEFQ48

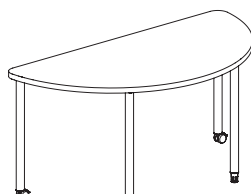

Fixed-Height
RTEAQ60

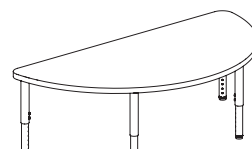

Floor Height Adjustable
RTEHQ60

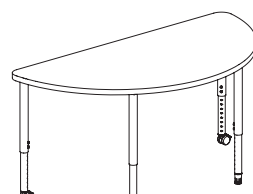

Sit Height Adjustable
RTEEQ60

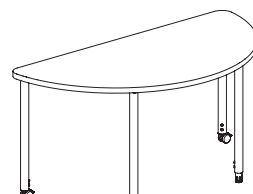

Sit-Stand Height Adjustable
RTEFQ60

Ruckus Arc Activity Table

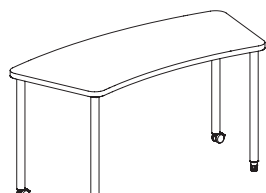

Fixed-Height
RTEAR24

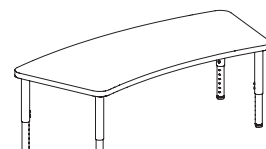

Floor Height Adjustable
RTEHR24

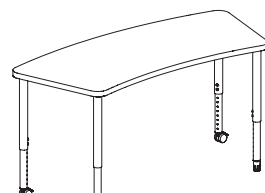

Sit Height Adjustable
RTEER24

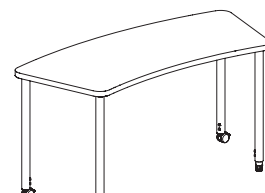

Sit-Stand Height Adjustable
RTEFR24

STATEMENT OF LINE

Ruckus Crescent Activity Table

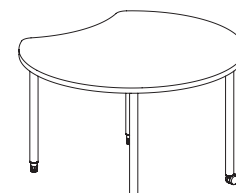

Fixed-Height
RTEAT48

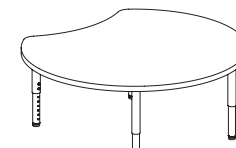

Floor Height Adjustable
RTEHT48

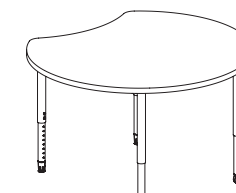

Sit Height Adjustable
RTEET48

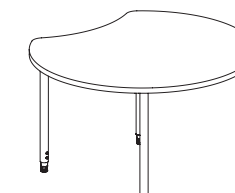

Sit-Stand Height Adjustable
RTEFT48

Ruckus Amoeba Activity Table

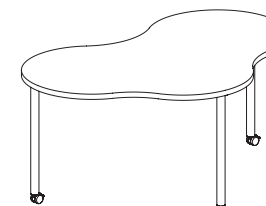

Fixed-Height
RTEAU3648
RTEAU4365

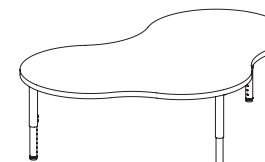

Floor Height Adjustable
RTEHU3648
RTEHU4365

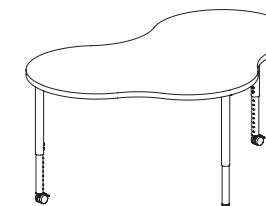

Sit Height Adjustable
RTEEU3648
RTEEU4365

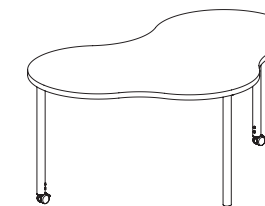

Sit-Stand Height Adjustable
RTEFU3648
RTEFU4365

Ruckus Wave Activity Table

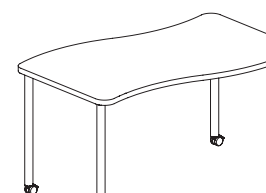

Fixed-Height
RTEAW3054
RTEAW3060

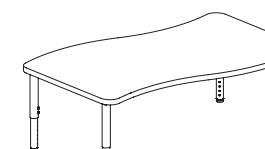

Floor Height Adjustable
RTEHW3054
RTEHW3060

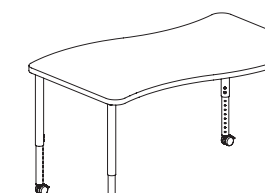

Sit Height Adjustable
RTEEW3054
RTEEW3060

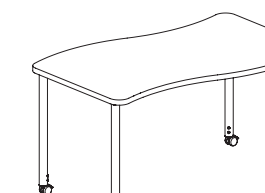

Sit-Stand Height Adjustable
RTEFW3054
RTEFW3060

Ruckus Quarter-Round Activity Table

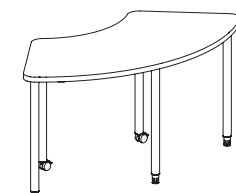

Fixed-Height
RTEAX24

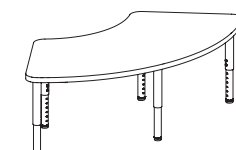

Floor Height Adjustable
RTEHX24

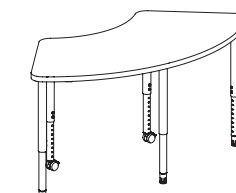

Sit Height Adjustable
RTEEX24

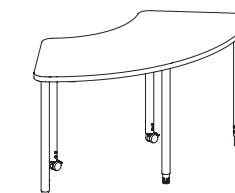

Sit-Stand Height Adjustable
RTEFX24



STATEMENT OF LINE

Optional Ruckus Activity Table Storage

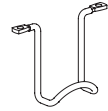

Book Bag Hook
RKUSBBH1

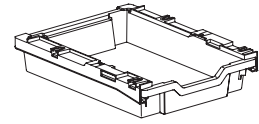

Removable Tote Storage
Storage Kit with 3" Tote
RKUSRT1

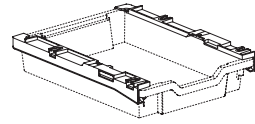

Removable Tote Storage
Storage Rail Only Kit
SKUSRTR01



Edge Color for 73P & 74P Edge

Akira	EAK	Black	LBK	Cottonwood	CO
Beigewood	EBZ	Brighton Walnut	LBW	Earthen Clay	EY
Belair	EBQ	Castle Oak	LCO	Espresso Metallic	EX
Biltmore Cherry	EBT	Cherry Storm	LCX	Everglade Shade	EV
Black	EBL	Classic Linen	LCI	Flannel	FN
Black Hills Oak	EBH	Cocobala	LCC	Glitz Metallic	GZ
Blue Grey	EGR	Crisp Linen	LRI	Hazy Jade	HJ
Brighton Walnut	EBW	Designer White	LDR	Honey Bee	HY
Castle Oak	ECO	Dove Grey	LDG	Light Tone	LG
Cayenne	ECY	Florence Walnut	LFC	Mardi Gras	MG
Cherry Storm	ECX	Friston Ash	LFH	Misty Brown	MY
Cocobala	ECC	Frosty White	LFW	Nemo	NE
Cool Grey	ECG	Graphite Nebula	LGN	Nordic	ND
Cumberland Walnut	ECJ	Grey	LGE	Poppy Red	PR
Dering Forest	EDF	High Rise	LHE	Purple Haze	PH
Designer White	EDR	Hollyberry	LHY	Rainforest	RQ
Everglade Shade	EEV	Island	LID	Raw Jasper	RJ
Fawn Cypress	EFQ	Italian Silver Ash	LIT	Rubber Ducky	RK
Flannel	EFN	Kensington Maple	LKM	Sand	SA
Florence Walnut	EFC	Lapis Blue	LLB	Sky Blue	SK
Friston Ash	EFH	Monticello Maple	LMT	Starlight Silver Metallic	SX
Frosty White	EFW	North Sea	LNA	Surf's Up	SP
Hartley Walnut	EHW	Ocean	LON	Tarragon	TQ
Hazy Jade	EHJ	Pinnacle Walnut	LPW	Twilight Shadow	TI
Italian Silver Ash	EIT	River Cherry	LRV	Ultra Blue	UB
Kensington Maple	EKM	Shadow Zephyr	LSR	Warm Grey	WG
Light Tone	ELG	Sterling Ash	LAZ	Zesty Lime	ZL
Mardi Gras	EMG	Titanium Evolv	LTV		
Misty Brown	EMY	White Nebula	LWL		
Monticello Maple	EMT	White Sand	LWN		
Multiplex	EMB	Windsor Mahogany	LWY		
Nemo	ENE				
Nordic	END				
Pinnacle Walnut	EPW				
Poppy Red	EPR				
Rainforest	ERQ				
Raleigh Walnut	ERW				
River Cherry	ERY				
Rubber Ducky	ERK				
Sand	ESA				
Sky Blue	ESK				
Solano Walnut	ESG				
Sterling Ash	EAZ				
Surf's Up	ESP				
Tarragon	ETQ				
Twilight Shadow	ETI				
Ultra Blue	EUB				
Valley Forge Elm	EVF				
Warm Grey	EWG				
White River Forest	EWR				
Windsor Mahogany	EWY				
Zesty Lime	EZL				

*Additional colors may be available. Please contact KI customer service at 1-800-424-2432

Surface Finish--Grade 2 Standard Laminate

Akira	LAK
Black Alicante	LBV
Black Hills Oak	LBH
Calcutta Marble	LCQ
Dering Forest	LDF
Fawn Cypress	LFQ
Ice Mist	LIM
Markerboard White	LMK
Valley Forge Elm	LVF
White River Forest	LWR

*Additional colors may be available. Please contact KI customer service at 1-800-424-2432

Painted Base Finish Color

Black	BL
Blue Grey	GR
Bronze Metallic	ZM
Cayenne	CY
Champagne Metallic	CM
Chrome	CH
Cool Grey	CG

Surface Finish--Grade 1 Standard Laminate

Beigewood	LBZ
Belair	LBQ
Biltmore Cherry	LBT

Starlight Silver Metallic	BRSX
Surf's Up	BRSP
Tarragon	BRTQ
Twilight Shadow	BRTI
Ultra Blue	BRUB
Warm Grey	BRWG
Zesty Lime	BRZL

Steel Book Box Color

Black	SBL
Blue Grey	SGR
Bronze Metallic	SZM
Cayenne	SCY
Champagne Metallic	SCM
Cool Grey	SCG
Cottonwood	SCO
Earthen Clay	SEY
Espresso Metallic	XEX
Everglade Shade	SEV
Flannel	SFN
Glitz Metallic	SGZ
Hazy Jade	SHJ
Honey Bee	SHY
Light Tone	SLG
Mardi Gras	SMG
Misty Brown	SMY
Nemo	SNE
Nordic	SND
Poppy Red	SPR
Purple Haze	SPH
Rainforest	SRQ
Raw Jasper	SRJ
Rubber Ducky	SRK
Sand	SSA
Sky Blue	SSK
Starlight Silver Metallic	SSX
Surf's Up	SSP
Tarragon	STQ
Twilight Shadow	STI
Ultra Blue	SUB
Warm Grey	SWG
Zesty Lime	SZL

Chrome requires an upcharge.

Book Basket Color

Black	BRBL
Blue Grey	BRGR
Bronze Metallic	BRZM
Cayenne	BRCY
Champagne Metallic	BRCM
Chrome	BRCH
Cool Grey	BRCG
Cottonwood	BRCO
Earthen Clay	BREY
Espresso Metallic	BREX
Everglade Shade	BREV
Flannel	BRFN
Glitz Metallic	BRGZ
Hazy Jade	BRHJ
Honey Bee	BRHY
Light Tone	BRLG
Mardi Gras	BRMG
Misty Brown	BRMY
Nemo	BRNE
Nordic	BRND
Poppy Red	BRPR
Purple Haze	BRPH
Rainforest	BRRQ
Raw Jasper	BRRJ
Rubber Ducky	BRRK
Sand	BRSA
Sky Blue	BRSK

Finish Cards

View color swatches for items listed within this document.

- [Paints](#)
- [Wood/Veneer](#)
- [Molded Edges](#)
- [Hard Plastics](#)
- [Plastics/Poly](#)
- [Laminates](#)
- [Edge Styles](#)
- [Glass](#)

Certain options referenced may not be available on GSA Schedule.



PRODUCT SPECIFICATIONS ■

Ruckus® Worktables

July 2022

TECHNICAL SPECIFICATIONS

Steel Base Shell

Components consist of top, bottom, sides, back uprights, bottom and top reinforcements, spot welded and metal insert gas (MIG) welded together.

The top of the cabinet is 19-gauge cold-rolled steel (C.R.S.) with 1 1/8" flanges, on four sides. The front face has an additional flange formed inward to provide additional strength.

The back of the cabinet is 20-gauge C.R.S. and is formed on four sides to provide strength. The bottom is 20-gauge C.R.S. with a flush upper surface and flanged downward to provide a welding surface with the sides and back. The front face is formed down 1 1/8" and inward to provide additional strength.

Each shell has double wall sides from 20-gauge C.R.S.; the inner panels of tote units are pierced on approximately 3 3/4" centers to allow molded plastic slide rails to be attached for totes. The cubby units are punched to accept fixed shelves dividing the section in half. The front flange of the outer side panels are formed to fit inside the channel formation of the side panel; the rear edge is offset formed for maximum strength and a flush alignment with the back return. Each shell has 18-gauge front and back upright members spot welded to the sides providing vertical strength. Top reinforcements are spot welded to the top and MIG welded to the vertical upright members to provide resistance against racking. Center partitions are two piece 20-gauge steel fabricated panels spot welded together with opposing flanges to be screw mounted to the top and bottom panels of the shell, punches with a matching pattern to the side of the units.

The bottom is fitted with two 18-gauge MIG welded in place structurally formed reinforcements which are located along the front and back of the cabinet. The reinforcements have two U-channel inner reinforcements with extruded holes to accept the tri-lobe screws that affix the casters.

Double-faced units are created using two single-faced units placed back-to-back, joined by a 12-gauge drop-in ganging plate and secured by the worksurface top.

Worksurface

Worksurfaces are designed to overhang the storage units. See dimensions for available sizes.

Laminate Worksurface

The laminate worksurfaces are 1 1/4" thick and consist of a particleboard core with a HPL surface, featuring a 74P (2 mm polypropylene) bonded edge for tamper and moisture resistance. All tops are pre-drilled for dowels and thumb screws for attaching the top to the units, as well as optional power modules and bag hooks at the job site.

Phenolic Resin Worksurface

Solid phenolic worksurface is a 1" thick, self-supporting flat panel based on thermosetting resins, homogeneously reinforced with cellulose fibers and manufactured under high heat and pressure. The worksurface has a pigmented resin, decorative surface that is electron-beam cured. All tops are pre-drilled for dowels and thumb screws for attaching the top to the units, as well as optional power modules and bag hooks at the job site.

Butcher Block Wood Worksurface

Hard Rock Maple wood butcher block worksurface is 1 3/4" thick and flat edge grain construction. Blocks are finger jointed, randomly placed and finished with clear, semi-gloss Varnique finish. All tops are pre-drilled for dowels and thumb screws for attaching the top to the units, as well as optional power modules and bag hooks at the job site.

TECHNICAL SPECIFICATIONS

Casters

Each unit has four industrial grade casters with 75 mm grey non-marking thermoplastic rubber wheels with a 25 mm tread. Casters are plate mounted with double ball bearing swivel head and a housing made of bright zinc plated pressed steel. The two front casters are total locking preventing swivel as well as rolling, the two rear casters are swivel and free rolling. The overall height of the casters are 100 mm.

Book Bag Hook (optional)

Optional book bag hook is formed from 1/4" solid wire rod. Chrome finish provides long lasting wear resistance. Hook fastens to the underside of top with two #12 x 3/4" Phillips pan-head screws. Book bag hook is field installed. Worktable overall size determines the number of book bag hooks included.

Power (optional)

All power modules have a 10 ft cord with 3-prong plug, and ship with wire management. Hook and ladder, screw-in wire management is provided to manage cords along the underside of the surface, as well as an adhesive-backed plastic channel to manage cords along the vertical surface of the storage. Modules and wire management are field installed. Modules are available in Black or KI's Cool Grey.

Dean Clamp-On Power Module

Dean clamp-on power module consists of two simplex receptacles (rated at 15 amps/125 volts), one USB-A port and one USB-C port. Available on 30" x 54" Ruckus worktables.

Dean Clamp-On Power Module with Wireless Charging (for Qi-enabled devices)

Dean clamp-on power module with wireless charging consists of two simplex receptacles (rated at 15 amps/125 volts), one USB-A port and one wireless charging lid (for Qi enabled devices). Available on 30" x 54" Ruckus worktables.

Dean Undersurface Power Module

Dean undersurface mounted power module consists of two simplex receptacles (rated at 15 amps/125 volts), one USB-A port and one USB-C port. Available on 48" x 54" & 60" x 54" Ruckus worktables.

Doors (optional)

The doors are single wall construction with a structural hinge channel running the length of the door. Self-closing European style hinges with 110-degree swing, provide 3-way adjustment of door to ensure consistent gapping and operation. Each steel door is standard with a key lock. All doors are inset.

Beveled Door Pull

Beveled door pull is made from cast zinc. It mounts using two machine screws to a steel door. It is available in a satin chrome or black finish.

Cubby Shelves

All fixed cubby shelves are 3/4" thick with flanges, front and back, constructed of 22-gauge material. Each shelf is screw mounted in four places with #10 screws into the outer panel and center panel to create separation between modules. Each section has one centered fixed shelf. Shelves are powder-coat painted.

Locks

Locks are included on every door:

Standard Key Lock

The standard lock is a high-security double-bit lock. The double-bit lock offers superior security when compared to a single-bit lock. Units are standard with random keys in a range of 994 different numbers. Specific keying combinations are available at no additional charge (this information must be included with order). Locks can be master keyed. Available in satin chrome or black finishes.



TECHNICAL SPECIFICATIONS

Finish

Units are offered in numerous powder-coat colors. Powder-coat application is a hybrid epoxy, baked on to provide a scratch and stain resistant finish. Base and doors may be specified in separate colors for no upcharge. Mechanical components are plated or finished with other protective coatings.

Totes

Totes are translucent polypropylene and available 3" or 6" depths for use with Ruckus worktables.

Tote Storage Removable Shelf

Removable shelves are constructed of 22-gauge steel with 3/4" thick with flanges front and back. Shelf is finished with powder-coat painted to color of choice. Each shelf will slide into place using the available tote rail set and locks into place once fully recessed. Each shelf can be easily removed or relocated by lifting up on the back of shelf and pulling it toward user.

Tote Storage Configurations

Ruckus worktables with tote storage, in any tote configuration beyond the preconfigured option, must be quoted through a product modification request. Additional totes can be ordered in kits with a quantity of six totes (rail sets included) and can be placed into any empty Ruckus worktables with Single or Double-Face tote storage, without the use of tools.

An optional shelf can be ordered to replace a tote. This shelf will slide into place using the available rail sets. Steel shelf is finished with powder-coated paint steel. Does not require tools to install.

Compliance

Ruckus storage meets or exceeds ANSI/BIFMA X.5.9-2019 and X.5.5-2019 standards.

Preconfigured Option:

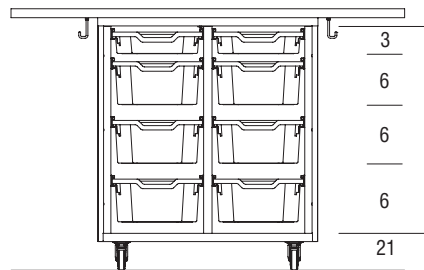

DIMENSIONS

Ruckus Worktables - Totes

General Dimensions - Totes			
	A (Height)	B (Width)	C (Depth)
3"	2 ¹⁵ / ₁₆ "	12 ¹ / ₄ "	16 ³ / ₄ "
6"	5 ⁷ / ₈ "	12 ¹ / ₄ "	16 ³ / ₄ "

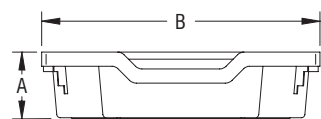

(front view)

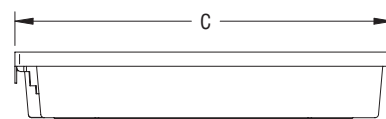

(side view)

DIMENSIONS

Ruckus Single-Face Worktables

Model	A Depth	B Width	C1 Overall Height (Laminate Worksurface) (1 ¹ / ₄ " thickness)	C2 Overall Height (Phenolic Resin Worksurface) (1" thickness)	C3 Overall Height (Butcher Block Wood Worksurface) (1 ³ / ₄ " thickness)	D Overhang	E Overhang
RCWT3054	30"	54"	35 ³ / ₄ "	35 ¹ / ₂ "	36 ¹ / ₄ "	11 ⁷ / ₈ "	5 ⁷ / ₈ "

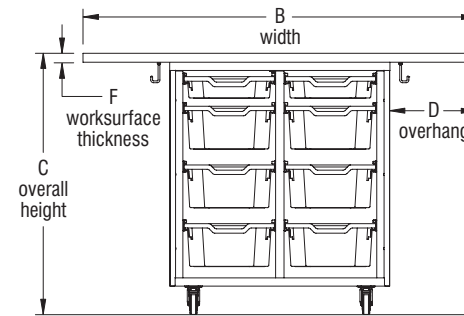

Ruckus Single-Face Worktables with Tote Storage (front view)

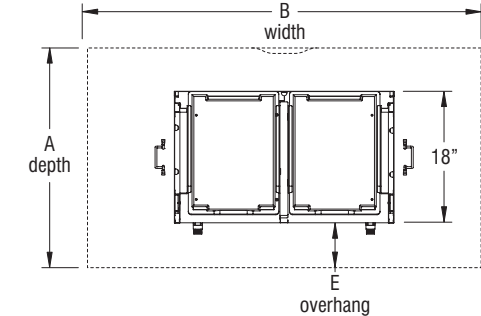

Ruckus Single-Face Worktables with Tote Storage (top view)

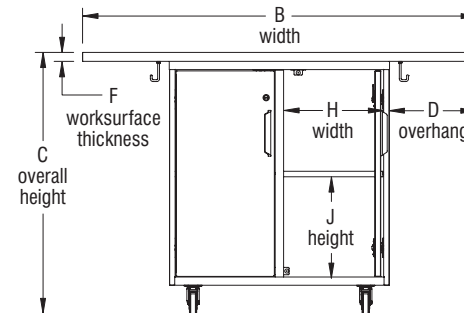

Ruckus Single-Face Worktables with Cubby Storage (front view)

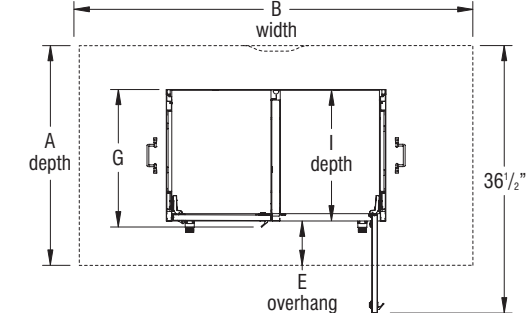

Ruckus Single-Face Worktables with Cubby Storage (top view)

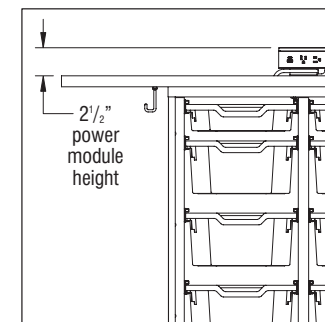

Ruckus Single-Face Worktable Power Module Location (front view)

General Dimensions Worksurface	
Worksurface	F Worksurface Thickness
Phenolic Resin	1"
Laminate	1 ¹ / ₄ "
Butcher Block	1 ³ / ₄ "

Ruckus Single-Face Worktables with Cubby Interior Clearance per Storage Compartment			
G (Door Pull to Back)	H (Width)	I (Depth)	J (Height)
18 ³ / ₄ "	13 ⁵ / ₈ "	17 ⁷ / ₈ "	13 ⁵ / ₈ "



DIMENSIONS

Ruckus Double-Face Worktables

Model	A Depth	B Width	C1 Overall Height (Laminate Worksurface) (1 1/4" thickness)	C2 Overall Height (Phenolic Resin Worksurface) (1" thickness)	C3 Overall Height (Butcher Block Wood Worksurface) (1 3/4" thickness)	D Overhang	E Overhang
RCWT4854	48"	54"	35 3/4"	35 1/2"	36 1/4"	11 7/8"	6"
RCWT6054	60"	54"	35 3/4"	35 1/2"	NA	11 7/8"	12"

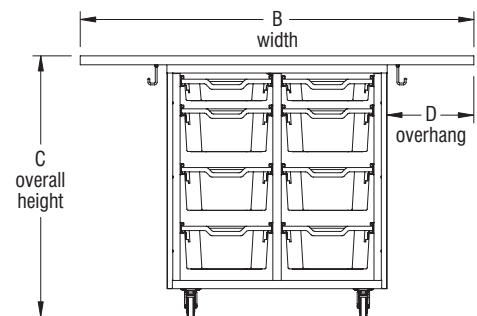

Ruckus Double-Face Worktables with Tote Storage (front view)

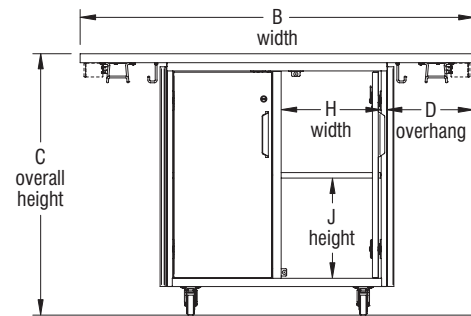

Ruckus Double-Face Worktables with Cubby Storage (front view)

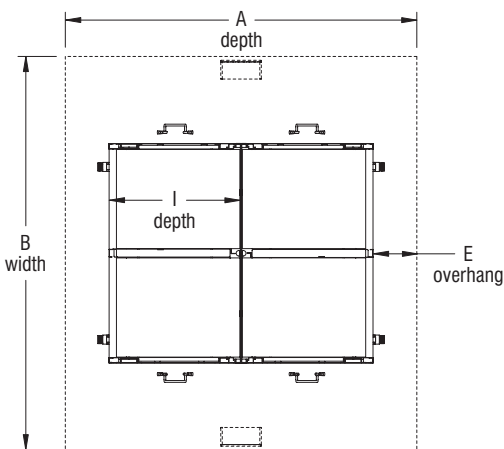

Ruckus Double-Face Worktables with Tote Storage (top view)

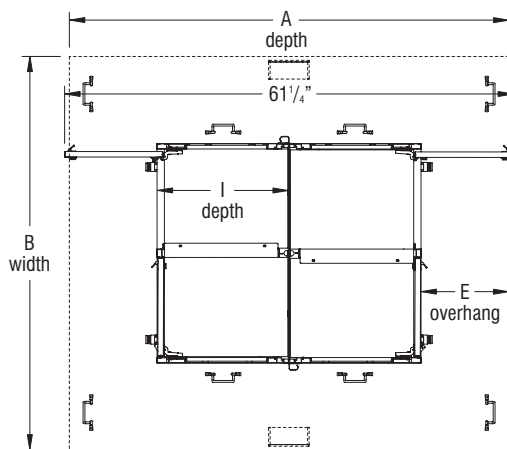

Ruckus Double-Face Worktables with Cubby Storage (top view)

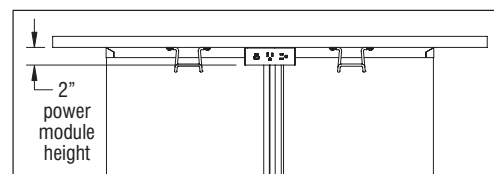

Ruckus Double-Face Worktable (model RCWT4854) Power Module Location (side view)

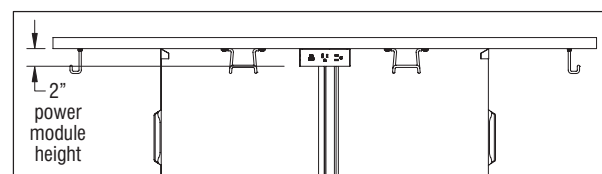

Ruckus Double-Face Worktable (model RCWT6054) Power Module Location (side view)

General Dimensions Worksurface	
Worksurface	F Worksurface Thickness
Phenolic Resin	1"
Laminate	1 1/4"
Butcher Block	1 3/4"

Ruckus Double-Face Worktables with Cubby Interior Clearance per Storage Compartment			
G (Door Pull to Door Pull)	H (Width)	I (Depth)	J (Height)
18 3/4"	13 5/8"	17 7/8"	13 5/8"

STATEMENT OF LINE

Ruckus Single-Face Worktables

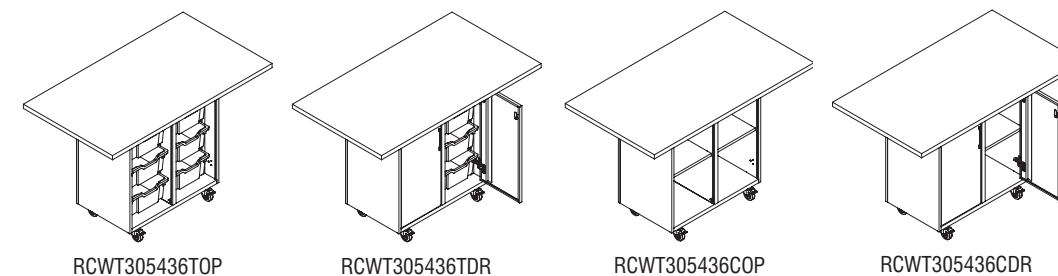

Ruckus Double-Face Worktables

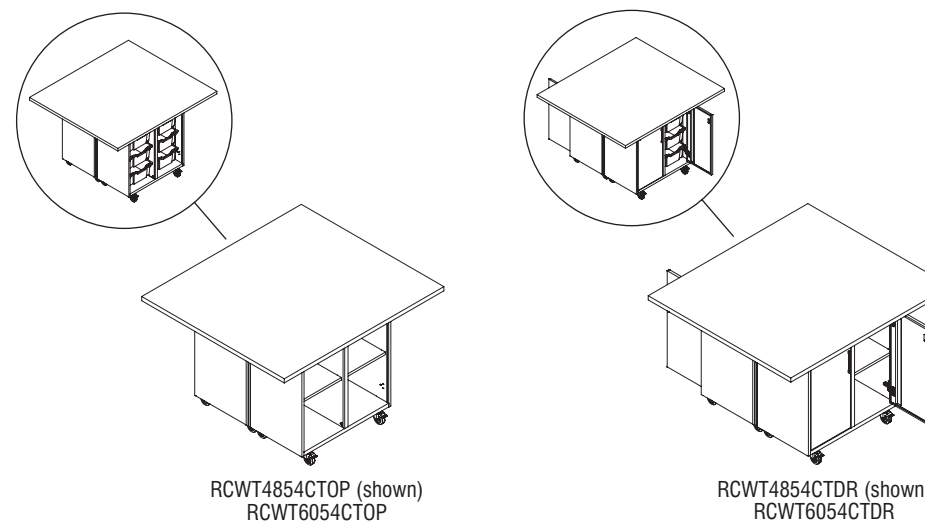
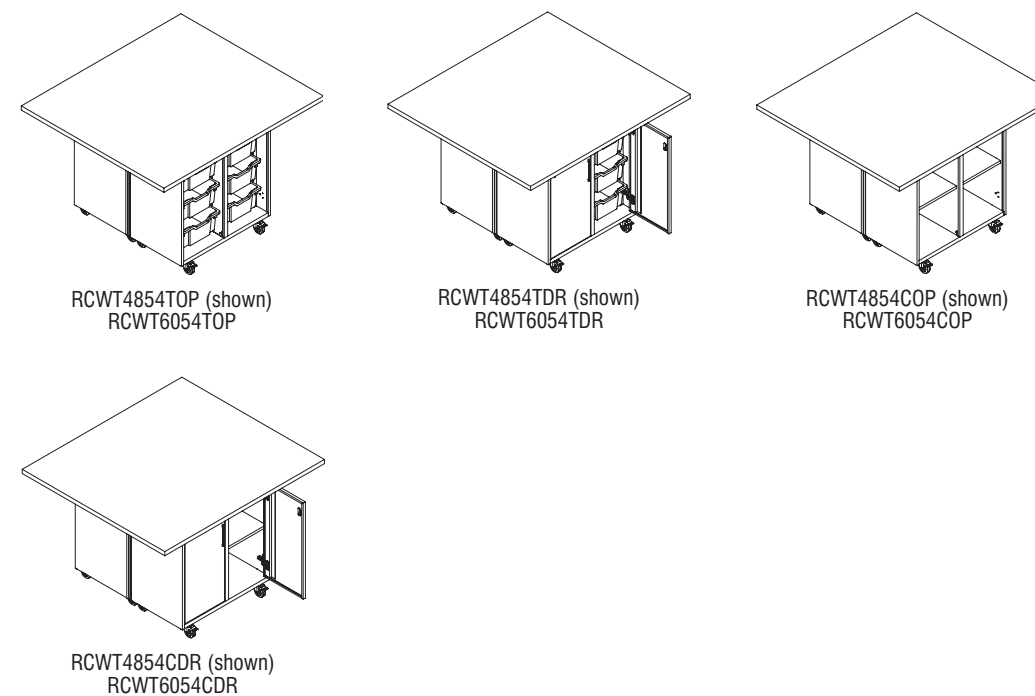



RUCKUS WORKTABLE FEATURES

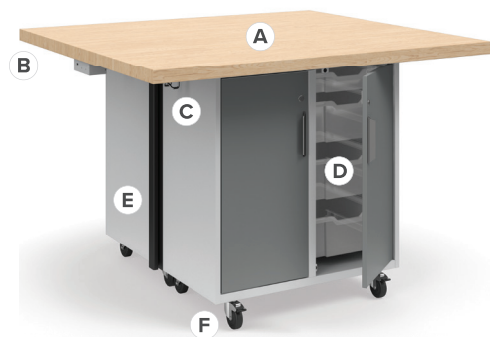

- A. Surface**
Three distinct worksurfaces support active learning; butcher block wood, laminate or phenolic resin.
- B. Optional Power**
Above or under surface power modules support classroom technology and provide charging for devices.
- C. Hooks**
Worktable overall size determines the number of book bag hooks included (one per user).
- D. Storage**
Storage within the base keeps learning resources at hand and learning spaces neat: cubby and or tote storage available with or without locking doors. Contrasting door colors available.
- E. Fits Through Doorways**
Toolless removable worksurfaces and two-piece base design ease relocation.
- F. Casters**
Industrial-grade 3" casters meet the rigorous demand of hands-on learning spaces.

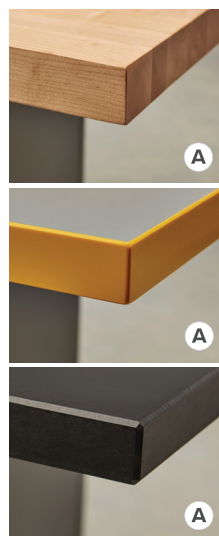



Power Module Color

Black	P1
Cool Grey	P2

Base Color & Paint Color

Black	BL
Blue Grey	GR
Bronze Metallic	ZM
Cayenne	CY
Champagne Metallic	CM
Cool Grey	CG
Cottonwood	CO
Earthen Clay	EY
Espresso Metallic	EX
Everglade Shade	EV
Flannel	FN
Glitz Metallic	GZ
Hazy Jade	HJ
Honey Bee	HY
Light Tone	LG
Mardi Gras	MG
Misty Brown	MY
Nemo	NE
Nordic	ND
Poppy Red	PR
Purple Haze	PH
Rainforest	RQ
Raw Jasper	RJ
Rubber Ducky	RK
Sand	SA
Sky Blue	SK
Starlight Silver Metallic	SX
Surf's Up	SP
Tarragon	TQ
Twilight Shadow	TI
Ultra Blue	UB
Warm Grey	WG
Zesty Lime	ZL

Top Color for Laminate Top with 74P Edge--Grade 1 Standard Laminate

Beigewood	LBZ
Belair	LBQ
Biltmore Cherry	LBT
Black	LBK
Brighton Walnut	LBW
Castle Oak	LCO
Cherry Storm	LCX
Classic Linen	LCI
Cocobala	LCC
Crisp Linen	LRI
Designer White	LDR
Dove Grey	LDG
Florence Walnut	LFC
Friston Ash	LFH
Frosty White	LFW
Graphite Nebula	LGN
Grey	LGE

High Rise	LHE
Hollyberry	LHY
Island	LID
Italian Silver Ash	LIT
Kensington Maple	LKM
Lapis Blue	LLB
Monticello Maple	LMT
North Sea	LNA
Ocean	LON
Pinnacle Walnut	LPW
River Cherry	LRV
Shadow Zephyr	LSR
Sterling Ash	LAZ
Titanium Evolv	LTV
White Nebula	LWL
White Sand	LWN
Windsor Mahogany	LWY

Top Color for Laminate Top with 74P Edge--Grade 2 Standard Laminate

Akira	LAK
Black Alicante	LBY
Black Hills Oak	LBH
Calcutta Marble	LCQ
Dering Forest	LDF
Fawn Cypress	LFQ
Ice Mist	LIM
Markerboard White	LMK
Valley Forge Elm	LVF
White River Forest	LWR

Top Color for Phenolic Resin Top

Black	RBL
-------	-----

Top Color for Butcher Block Wood Top

Maple	WME
-------	-----

Edge Color for 74P Edge

Akira	EAK
Beigewood	EBZ
Belair	EBQ
Biltmore Cherry	EBT
Black	EBL
Black Hills Oak	EBH
Blue Grey	EGR
Brighton Walnut	EBW
Castle Oak	ECO
Cayenne	ECY
Cherry Storm	ECX
Cocobala	ECC
Cool Grey	ECG
Cumberland Walnut	ECJ
Dering Forest	EDF
Designer White	EDR
Everglade Shade	EEV
Fawn Cypress	EFQ
Flannel	EFN
Florence Walnut	EFC
Friston Ash	EFH

Frosty White	EFW
Hartley Walnut	EHW
Hazy Jade	EHJ
Italian Silver Ash	EIT
Kensington Maple	EKM
Light Tone	ELG
Mardi Gras	EMG
Misty Brown	EMY
Monticello Maple	EMT
Multiplex	EMB
Nemo	ENE
Nordic	END
Pinnacle Walnut	EPW
Poppy Red	EPR
Rainforest	ERQ
Raleigh Walnut	ERW
River Cherry	ERY
Rubber Ducky	ERK
Sand	ESA
Sky Blue	ESK
Solano Walnut	ESG
Sterling Ash	EAZ
Surf's Up	ESP
Tarragon	ETQ
Twilight Shadow	ETI
Ultra Blue	EUB
Valley Forge Elm	EVF
Warm Grey	EWG
White River Forest	EWR
Windsor Mahogany	EWY
Zesty Lime	EZL

Front Door Color

Black	FBL
Blue Grey	FGR
Bronze Metallic	FZM
Cayenne	FCY
Champagne Metallic	FCM
Cool Grey	FCG
Cottonwood	FCO
Earthen Clay	FEY
Espresso Metallic	FEX
Everglade Shade	FEV
Flannel	FFN
Glitz Metallic	FGZ
Hazy Jade	FHJ
Honey Bee	FHY
Light Tone	FLG
Mardi Gras	FMG
Misty Brown	FMY
Nemo	FNE
Nordic	FND
Poppy Red	FPR
Purple Haze	FPH
Rainforest	FRQ
Raw Jasper	FRJ
Rubber Ducky	FRK
Sand	FSA

Sky Blue	FSK
Starlight Silver Metallic	FSX
Surf's Up	FSP
Tarragon	FTQ
Twilight Shadow	FTI
Ultra Blue	FUB
Warm Grey	FWG
Zesty Lime	FZL

Door Pull Color

Beveled pull Satin Chrome	S5
Beveled pull Black	S6

Lock Color

Black	BLL
Satin Chrome	SCL

Paint Color

Black	BL
Blue Grey	GR
Bronze Metallic	ZM
Cayenne	CY
Champagne Metallic	CM
Cool Grey	CG
Cottonwood	CO
Earthen Clay	EY
Espresso Metallic	EX
Everglade Shade	EV
Flannel	FN
Glitz Metallic	GZ
Hazy Jade	HJ
Honey Bee	HY
Light Tone	LG
Mardi Gras	MG
Misty Brown	MY
Nemo	NE
Nordic	ND
Poppy Red	PR
Purple Haze	PH
Rainforest	RQ
Raw Jasper	RJ
Rubber Ducky	RK
Sand	SA
Sky Blue	SK
Starlight Silver Metallic	SX
Surf's Up	SP
Tarragon	TQ
Twilight Shadow	TI
Ultra Blue	UB
Warm Grey	WG
Zesty Lime	ZL

Finish Color

Black	BL
Cool Grey	CG

Finish Cards

View color swatches for items listed within this document.

Paints	Wood/Veneer	Molded Edges	Hard Plastics
Plastics/Poly	Laminates	Edge Styles	Glass

Certain options referenced may not be available on GSA Schedule.



PRODUCT SPECIFICATIONS ■

Ruckus® Cubby & Bookcase

November 2023

TECHNICAL SPECIFICATIONS

Shell

The shell is a common construction that consists of steel bottom, sides, back, uprights, with laminated wood top. Inside double-face units, a center divider is screw mounted in each section to separate the front and back sides. All panel bottoms are mounted on one common steel base.

Single-Face Units - Overall Size with Casters or Glides Included: Nominal vs. Actual

36w x 18d x 36h storage: 36¹/₈" wide by 18¹/₄" deep by 36" high

36w x 18d x 42h storage: 36¹/₈" wide by 18¹/₄" deep by 42" high

54w x 18d x 36h storage: 53⁵/₈" wide by 18¹/₄" deep by 36" high

54w x 18d x 42h storage: 53⁵/₈" wide by 18¹/₄" deep by 42" high

Double-Face Units - Overall Size with Casters or Glides Included: Nominal vs. Actual

36w x 24d x 36h storage: 36¹/₈" wide by 24¹/₄" deep by 36" high

36w x 24d x 42h storage: 36¹/₈" wide by 24¹/₄" deep by 42" high

54w x 24d x 36h storage: 53⁵/₈" wide by 24¹/₄" deep by 36" high

54w x 24d x 42h storage: 53⁵/₈" wide by 24¹/₄" deep by 42" high

Laminate Worksurface - Storage

The laminate worksurfaces are 1¹/₄" thick and consist of a particleboard core with a HPL surface. 74P (2 mm PVC-free) banding is applied to the edges. All tops are pre-drilled for mounting of end panels, center panel(s), center dividers and are assembled in the factory.

Vertical Panels

Each 1" thick vertical panel features double-wall steel construction. The outer vertical panel consists of 20-gauge material with double flanges formed on both vertical edges and single flanges formed on the top and bottom. The vertical edges of the outer panel have an 18-gauge reinforcing member welded in place to provide structural integrity. The inner vertical panel is 18-gauge with double flanges formed on the vertical edges and single flanges formed on the top and bottom edges. Two keyhole pads of 16-gauge are welded into the top of the end vertical panel to interface with shoulder screws for mounting to the laminate top. The outer and inner panels are spot welded together, as well as fastened together at the bottom with the threaded inserts that accept the mounting bolt for the base. Bonded to both surfaces within the panel is a lightweight honeycomb core material to improve panel rigidity. Cubby vertical interior panels feature pre-punched holes for connecting the center dividers, shelves, coat hook, hinge mounts and slot for lock engagement. Bookcase vertical interior panels feature pre-punched holes for connecting the center dividers, adjustable shelves, coat hook, hinge mounts and slot for lock engagement.

Center Divider (Double-Face Units Only)

One center divider is screw mounted in each section to separate the front and back sides. This is constructed of 20-gauge material with ³/₄" side flanges for mounting. The divider is a structural component, and has the security feature that it is not removable from any single storage component. This prevents unauthorized access when locking doors are used.

Base

The 1¹/₈" thick base ties together the vertical panels creating the bottom and complete structure. Bases are 18-gauge steel. Each base also contains an 18-gauge reinforcement strip on the front and back side of the base bottom. Each reinforcement strip is spot welded in place. Each strip consists of two ¹/₂" weld nuts on each end to accept the caster or glide stem.

TECHNICAL SPECIFICATIONS

Casters or Glides

Each unit may be specified with either casters or glides. Casters or glides do not extend out from the side of the unit shell. Both caster and glides have a ¹/₂" diameter threaded stud to mount to the bottom of the base and are interchangeable.

Casters

All caster bodies are twin-wheel hooded design with 2³/₄" diameter wheels. All four casters swivel and two casters will have a lock. Casters will be black.

Glides

All glides are 2³/₄" telescoping adjustable glides. Glides are made of a two-piece construction and both pieces are made of durable nylon. Each glide has a white base with a black body.

Hooks - Storage

Utility hooks are made of 11-gauge steel and have a grey powder-coat finish. Each hook is attached to the interior sides of the opening using two #10 tapping screws.

Doors

The doors are single wall construction with a structural hinge channel running the length of the door. Self-closing European style hinges with 110-degree swing, provide 3-way adjustment of door to ensure consistent gapping and operation. The steel door is standard with a lock and is specified with one of the lock options (see lock section below). If left or right designation is noted, left or right specifies which side it is hinged on. All doors are inset.

Door Pulls

A door pull is only available when the standard key lock is chosen. Refer to "Locks" specifications on the next page for full details. One pull type is available:

Beveled Pull

Made from cast zinc. It mounts by use of two machine screws to a steel door. It is available in a satin chrome or painted black powder-coat finish.

Shelves

All shelves are ³/₄" thick with flanges, front and back, constructed of 22-gauge material. Each cubby fixed shelf is screw mounted in four places with #10 screws into the outer panel and center panel to create separation between modules. Each bookcase unit features two adjustable shelves per section which can be adjusted in 1" increments. The shelves are mounted in two places, with adjustable shelf brackets into the outer panel and center panel, to create separation between modules.

Cubbies - Open Units

Each cubby unit includes two fixed shelves per section.

Interior Clearance:

36" high unit: 16¹/₂" wide by 10⁷/₈" deep by 9⁵/₈" high

42" high unit: 16¹/₂" wide by 10⁷/₈" deep by 11⁵/₈" high

Cubbies - With Doors

Each cubby with door includes one locking door and two fixed shelves per section.

Interior Clearance:

36" high unit: 16¹/₂" wide by 10⁷/₈" deep by 9⁵/₈" high

42" high unit: 16¹/₂" wide by 10⁷/₈" deep by 11⁵/₈" high

Bookshelves

Each bookshelf unit features two adjustable shelves per section.

Interior Clearance:

36" high unit: 34" wide by 10⁷/₈" deep by 9⁵/₈" high

42" high unit: 34" wide by 10⁷/₈" deep by 11⁵/₈" high



TECHNICAL SPECIFICATIONS

Bookshelves (cont.)

Bookcase Capacity

The most practical way to figure book capacity is on a linear feet basis. A good average for public and school libraries is 8.3 books per linear foot. The children's section capacity in elementary schools and public libraries may be raised to 15 books per foot, while the shelving capacity for academic libraries is averaged to be 6.7 books per linear foot. A per shelf capacity of 25 adult, 45 children, and 20 academic books can be established.

Ruckus Bookcase - Book Capacity			
Bookcase Type	Adult Book Capacity	Children Book Capacity	Academic Book Capacity
Single-Face Bookcase	69 books per unit (23 books per shelf)	126 books per unit (42 books per shelf)	54 books per unit (18 books per shelf)
Double-Face Bookcase	138 books per unit (23 books per shelf)	252 books per unit (42 books per shelf)	108 books per unit (18 books per shelf)

Bookcase shelves have a weight capacity of 132 lb per shelf.

Locks

Locks are available anywhere a door is used, with four locking options for Ruckus Storage:

Standard Key Lock (comes with pull option only)

The standard lock is a high-security double-bit lock. The double-bit lock offers superior security when compared to a single-bit lock. Units are standard with random keys in a range of 994 different numbers. Specific keying combinations are available at no additional charge (this information must be included with order). Locks can be master keyed.

Padlock

Robust zinc housing allows the end user to apply their own combination lock. Lock is backed with a stainless steel escutcheon plate to protect the paint finish.

Combination Lock

A 4-dial combination lock allows user to access cubby without the need of a key. All locks are shipped with a factory set code 3333, combination is set by the end user or facility manager. In the case of lost or forgotten codes, a master key override will unlock the unit and allow the lock to be recoded. Combination lock features solid zinc construction and a four digit combination allows up to 10,000 unique codes.

Digital Lock

Stand-alone battery operated lock allows user immediate and simple keypad access without the need of a key. All locks are shipped with a factory set code 2244, the new access code is set by the end user or facility manager. Users have the flexibility to set and change a personal entry code, while a preset master code ensures that supervisor access is always available, or in an emergency, the key code can be overridden.

Features:

- Up to 80,000 operating cycle's battery life
- Low battery warning
- Battery failure key override
- 8-digit master code and 6-digit sub-master codes
- 4-digit user code (10,000 unique codes)
- 6-digit technician code
- Code changeable
- Not suitable for chlorinated environments
- Can be programmed for single use, set at time of use, or fixed combination mode

Finish

Units are offered in numerous powder-coat colors. Powder-coat application is a hybrid epoxy, baked on to provide a scratch and stain resistant finish. Shells and doors may be specified in separate colors for no upcharge. Mechanical components are plated or finished with other protective coatings.

DIMENSIONS

General Dimensions - Single-Face Cubbies & Bookcases			
A (Height)	B (Width)	C (Depth)	D (Door Pull to Back)
36"	36 ¹ / ₈ "-53 ⁵ / ₈ "	18 ¹ / ₄ "	18 ⁷ / ₈ "
42"	36 ¹ / ₈ "-53 ⁵ / ₈ "	18 ¹ / ₄ "	18 ⁷ / ₈ "

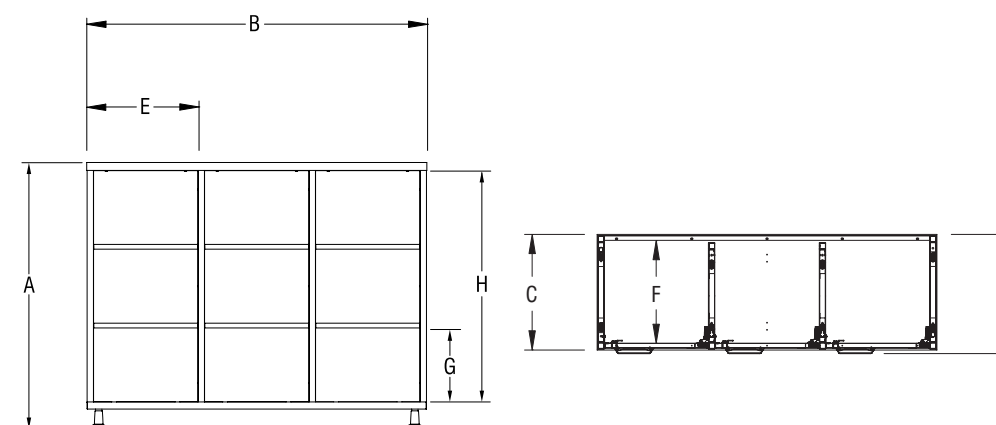

Front View
(54" Double-Face Open
Cubby shown)

Top View
(54" Single-Face Cubby
with Doors shown)

Interior Clearance per Storage Compartment				
Storage Height	E (Width)	F (Depth)	G (Height)	H (Height)
36" Single-Face Open Cubby	16 ¹ / ₂ "	17 ⁵ / ₈ "	9 ⁵ / ₈ "	30 ¹ / ₂ "
42" Single-Face Open Cubby	16 ¹ / ₂ "	17 ⁵ / ₈ "	11 ⁵ / ₈ "	37 ³ / ₁₆ "
36" Single-Face Cubby w/ Door	16 ¹ / ₂ "	16 ³ / ₄ "	9 ⁵ / ₈ "	30 ¹ / ₂ "
42" Single-Face Cubby w/ Door	16 ¹ / ₂ "	16 ³ / ₄ "	11 ⁵ / ₈ "	37 ³ / ₁₆ "
36" Single-Face Bookcase*	34"	17 ⁵ / ₈ "	4 ³ / ₄ " - 25 ³ / ₄ "	30 ¹ / ₂ "
42" Single-Face Bookcase*	34"	17 ⁵ / ₈ "	4 ³ / ₄ " - 31 ³ / ₄ "	37 ³ / ₁₆ "

*Note: Ruckus Bookcase uses adjustable shelves. Height G shows the range that is available.



DIMENSIONS

General Dimensions - Double-Face Cubbies & Bookcases			
A (Height)	B (Width)	C (Depth)	D (Door Pull to Door Pull)
36"	36 ¹ / ₈ "-53 ⁵ / ₈ "	24 ¹ / ₄ "	24 ⁵ / ₈ "
42"	36 ¹ / ₈ "-53 ⁵ / ₈ "	24 ¹ / ₄ "	24 ⁵ / ₈ "

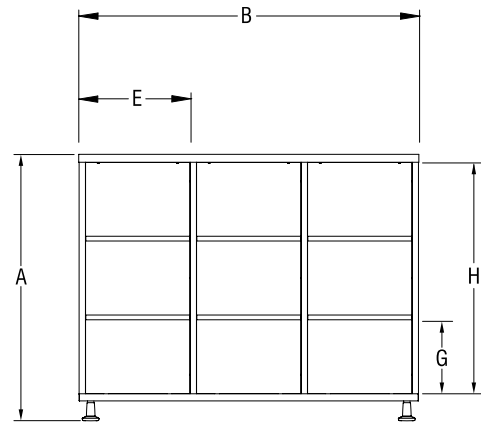

Front View
(54" Double-Face Open
Cubby shown)

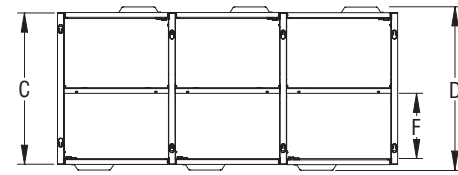

Top View
(54" Double-Face Cubby
with Doors shown)

Interior Clearance per Storage Compartment				
Storage Height	E (Width)	F (Depth)	G (Height)	H (Height)
36" Double-Face Open Cubby	16 ¹ / ₂ "	11 ³ / ₄ "	9 ⁵ / ₈ "	30 ¹ / ₂ "
42" Double-Face Open Cubby	16 ¹ / ₂ "	11 ³ / ₄ "	11 ⁵ / ₈ "	37 ³ / ₁₆ "
36" Double-Face Cubby w/ Door	16 ¹ / ₂ "	10 ⁷ / ₈ "	9 ⁵ / ₈ "	30 ¹ / ₂ "
42" Double-Face Cubby w/ Door	16 ¹ / ₂ "	10 ⁷ / ₈ "	11 ⁵ / ₈ "	37 ³ / ₁₆ "
36" Double-Face Bookcase*	34"	11 ³ / ₄ "	4 ³ / ₄ " - 25 ³ / ₄ "	30 ¹ / ₂ "
42" Double-Face Bookcase*	34"	11 ³ / ₄ "	4 ³ / ₄ " - 31 ³ / ₄ "	37 ³ / ₁₆ "

*Note: Ruckus Bookcase uses adjustable shelves. Height G shows the range that is available.

STATEMENT OF LINE

Ruckus Single-Face Cubbies

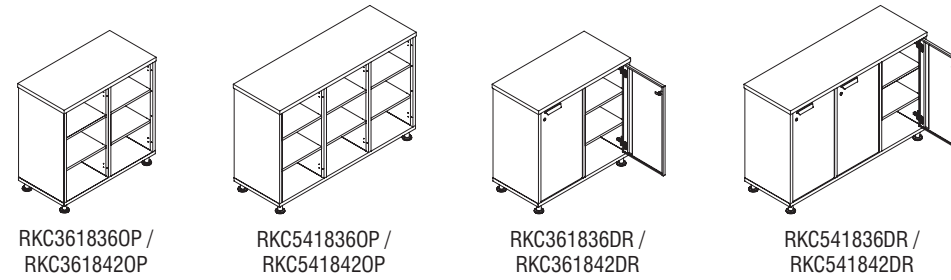

RKC3618360P /
RKC3618420P

RKC5418360P /
RKC5418420P

RKC361836DR /
RKC361842DR

RKC541836DR /
RKC541842DR

Ruckus Single-Face Bookcase

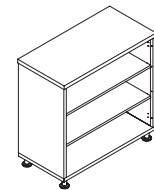

RKB361836 /
RKB361842

Ruckus Double-Face Cubbies

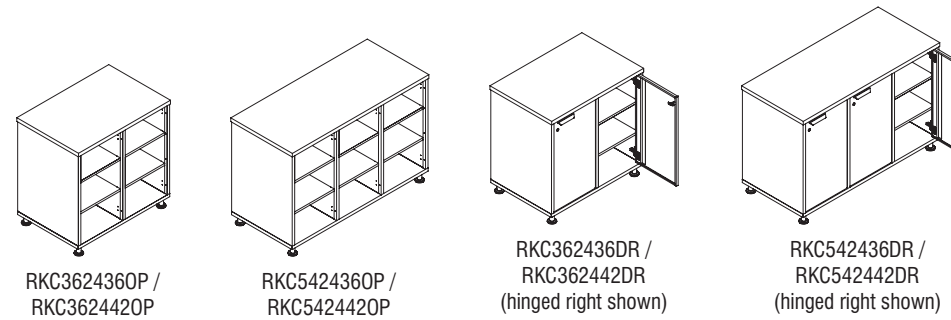

RKC3624360P /
RKC3624420P

RKC5424360P /
RKC5424420P

RKC362436DR /
RKC362442DR
(hinged right shown)

RKC542436DR /
RKC542442DR
(hinged right shown)

Ruckus Double-Face Bookcase

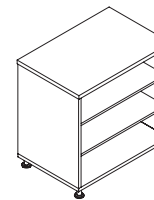

RKB362436 /
RKB362442

Ruckus Locks

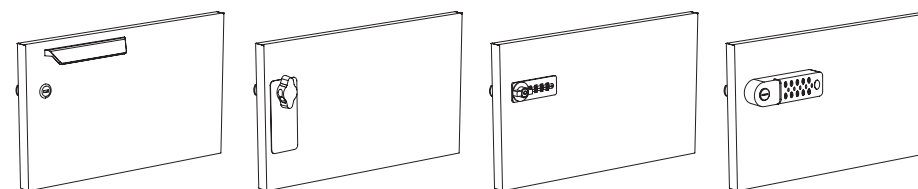

Standard Key Lock

Padlock

Combination Lock

Digital Lock



Shell Color		Raw Jasper	FRJ	Ice Mist	LIM		
Black	BL	Rubber Ducky	FRK	Markerboard White	LMK	Pull Color	
Blue Grey	GR	Sand	FSA	Valley Forge Elm	LVF	Beveled pull Satin Chrome	S5
Bronze Metallic	ZM	Sky Blue	FSK	White River Forest	LWR	Beveled pull Black	S6
Cayenne	CY	Starlight Silver Metallic	FSX				
Champagne Metallic	CM	Surf's Up	FSP	Edge Color-For 74P Edge		Tote Storage Lock Color	
Cool Grey	CG	Tarragon	FTQ	Akira	EAK	Black	BLL
Cottonwood	CO	Twilight Shadow	FTI	Beigewood	EBZ	Satin Chrome	SCL
Earthen Clay	EY	Ultra Blue	FUB	Belair	EBQ		
Espresso Metallic	EX	Warm Grey	FWG	Biltmore Cherry	EBT	Paint Color	
Everglade Shade	EV	Zesty Lime	FZL	Black	EBL	Black	BL
Flannel	FN			Black Hills Oak	EBH	Blue Grey	GR
Glitz Metallic	GZ	Surface Finish--Grade 1 Standard Laminate		Blue Grey	EGR	Bronze Metallic	ZM
Hazy Jade	HJ	Beigewood	LBZ	Brighton Walnut	EBW	Cayenne	CY
Honey Bee	HY	Belair	LBQ	Castle Oak	ECO	Champagne Metallic	CM
Light Tone	LG	Biltmore Cherry	LBT	Cayenne	ECY	Cool Grey	CG
Mardi Gras	MG	Black	LBK	Cherry Storm	ECX	Cottonwood	CO
Misty Brown	MY	Brighton Walnut	LBW	Cocobala	ECC	Earthen Clay	EY
Nemo	NE	Castle Oak	LCO	Cool Grey	ECG	Espresso Metallic	EX
Nordic	ND	Cherry Storm	LCX	Cumberland Walnut	ECJ	Everglade Shade	EV
Poppy Red	PR	Classic Linen	LCI	Dering Forest	EDF	Flannel	FN
Purple Haze	PH	Cocobala	LCC	Designer White	EDR	Glitz Metallic	GZ
Rainforest	RQ	Crisp Linen	LRI	Everglade Shade	EEV	Hazy Jade	HJ
Raw Jasper	RJ	Designer White	LDR	Fawn Cypress	EFQ	Honey Bee	HY
Rubber Ducky	RK	Dove Grey	LDG	Flannel	EFN	Light Tone	LG
Sand	SA	Florence Walnut	LFC	Florence Walnut	EFC	Mardi Gras	MG
Sky Blue	SK	Friston Ash	LFH	Friston Ash	EFH	Misty Brown	MY
Starlight Silver Metallic	SX	Frosty White	LFW	Frosty White	EFW	Nemo	NE
Surf's Up	SP	Graphite Nebula	LGN	Hartley Walnut	EHW	Nordic	ND
Tarragon	TQ	Grey	LGE	Hazy Jade	EHJ	Poppy Red	PR
Twilight Shadow	TI	High Rise	LHE	Italian Silver Ash	EIT	Purple Haze	PH
Ultra Blue	UB	Hollyberry	LHY	Kensington Maple	EKM	Rainforest	RQ
Warm Grey	WG	Island	LID	Light Tone	ELG	Raw Jasper	RJ
Zesty Lime	ZL	Italian Silver Ash	LIT	Mardi Gras	ELM	Rubber Ducky	RK
		Kensington Maple	LKM	Misty Brown	EMG	Sand	SA
		Lapis Blue	LLB	Monticello Maple	EMY	Sky Blue	SK
		Monticello Maple	LMT	Multiplex	EMT	Starlight Silver Metallic	SX
Front Door Color		North Sea	LNA	Nemo	ENE	Surf's Up	SP
Black	FBL	Ocean	LON	Nordic	END	Tarragon	TQ
Blue Grey	FGR	Pinnacle Walnut	LPW	Pinnacle Walnut	EPW	Twilight Shadow	TI
Bronze Metallic	FZM	River Cherry	LRY	Poppy Red	EPR	Ultra Blue	UB
Cayenne	FCY	Shadow Zephyr	LSR	Rainforest	ERQ	Warm Grey	WG
Champagne Metallic	FCM	Sterling Ash	LAZ	Raleigh Walnut	ERW	Zesty Lime	ZL
Cool Grey	FCG	Titanium Evolv	LTV	River Cherry	ERY		
Cottonwood	FCO	White Nebula	LWL	Rubber Ducky	ERK		
Earthen Clay	FEY	White Sand	LWN	Sand	ESA		
Espresso Metallic	FEX	Windsor Mahogany	LWY	Sky Blue	ESK		
Everglade Shade	FEV			Solano Walnut	ESG		
Flannel	FFN			Sterling Ash	EAZ		
Glitz Metallic	FGZ			Surf's Up	ESP		
Hazy Jade	FHJ			Tarragon	ETQ		
Honey Bee	FHY			Twilight Shadow	ETI		
Light Tone	FLG	Surface Finish--Grade 2 Standard Laminate		Ultra Blue	EUB		
Mardi Gras	FMG	Akira	LAK	Valley Forge Elm	EVF		
Misty Brown	FMY	Black Alicante	LBY	Warm Grey	EWG		
Nemo	FNE	Black Hills Oak	LBH	White River Forest	EWR		
Nordic	FND	Calcutta Marble	LCQ	Windsor Mahogany	EWY		
Poppy Red	FPR	Dering Forest	LDF	Zesty Lime	EZL		
Purple Haze	FPH	Fawn Cypress	LFQ				
Rainforest	FRQ						

Finish Cards

View color swatches for items listed within this document.

Paints	Wood/Veneer	Molded Edges	Hard Plastics
Plastics/Poly	Laminates	Edge Styles	Glass

Certain options referenced may not be available on GSA Schedule.



PRODUCT SPECIFICATIONS ■

Ruckus® Tote Storage

October 2024

TECHNICAL SPECIFICATIONS

Shell

Components consist of top, bottom, sides, back, uprights, bottom and top reinforcements, spot welded and MIG welded together.

The top is 19-gauge cold-rolled steel (C.R.S.) with $1\frac{1}{8}$ " flanges, on four sides. The front face has an additional flange formed inward to provide additional strength.

The back is 20-gauge C.R.S. and is formed on three sides to provide a flush seamless back and top surface.

The bottom is 20-gauge C.R.S. with a flush upper surface and flanged downward to provide a welding surface with the sides and back. The front face is formed down $1\frac{1}{8}$ " and inward to provide additional strength.

Each shell has double wall sides and center partition(s) fabricated from 20-gauge C.R.S.; the inner panels are pierced on approximately $3\frac{3}{4}$ " centers to allow molded plastic slide rails to be attached for totes. The front flange of the outer panels is formed to fit inside the channel formation of the side panel; the rear edge is offset formed for maximum strength.

Each shell's front and back has 18-gauge upright members spot welded to the sides providing vertical strength. Top reinforcements are MIG welded to the vertical upright members to provide resistance against racking.

Center partitions are two piece 20-gauge steel fabricated panels spot welded together with apposing flanges to be screw mounted to the top and bottom panels of the shell.

The bottom is fitted with two 18-gauge MIG welded in place structurally formed reinforcements which are located along the front and back of the cabinet. The reinforcements have 2-cast aluminum plates mounted to their ends to distribute weight and accept the caster or glide stem.

Single-Face Tote Storage - Overall Size with Casters or Glides Included: Nominal vs. Actual

30w x 18d x 28h tote storage: $29\frac{5}{16}$ " wide by $18\frac{1}{8}$ " deep by $27\frac{3}{4}$ " high

30w x 18d x 41h tote storage: $29\frac{5}{16}$ " wide by $18\frac{1}{8}$ " deep by $40\frac{3}{4}$ " high

44w x 18d x 28h tote storage: $43\frac{15}{16}$ " wide by $18\frac{1}{8}$ " deep by $27\frac{3}{4}$ " high

44w x 18d x 41h tote storage: $43\frac{15}{16}$ " wide by $18\frac{1}{8}$ " deep by $40\frac{3}{4}$ " high

Laminate Worksurface (optional)

The laminate worksurfaces are $1\frac{1}{4}$ " thick and consist of a particleboard core with a HPL surface. 74P (2 mm PVC-free) banding is applied to the edges.

Single-Face Tote Storage - Overall Size with Casters, Glides and Worksurface Included:

Nominal vs. Actual

30w x 18d x 29h tote storage: $30\frac{1}{4}$ " wide by $18\frac{1}{4}$ " deep by 29" high

30w x 18d x 42h tote storage: $30\frac{1}{4}$ " wide by $18\frac{1}{4}$ " deep by 42" high

44w x 18d x 29h tote storage: $44\frac{1}{16}$ " wide by $18\frac{1}{4}$ " deep by 29" high

44w x 18d x 42h tote storage: $44\frac{1}{16}$ " wide by $18\frac{1}{4}$ " deep by 42" high

TECHNICAL SPECIFICATIONS

Casters or Glides

Each unit may be specified with either casters or glides. Casters or glides do not extend out from the side of the unit shell. Both caster and glides have a $\frac{1}{2}$ " diameter threaded stud to mount to the bottom of the base and are interchangeable.

Casters:

All casters are twin-wheeled, non-hooded, molded nylon with $2\frac{3}{4}$ " diameter wheels. All four casters swivel and two casters will have a lock. Casters are Black in color.

Glides:

All glides are $2\frac{3}{4}$ " telescoping adjustable glides. Glides shall be made of two-piece construction and both pieces are made of durable nylon. Each glide has a white base with a black body.

Doors (optional)

Tote cabinet doors feature double wall construction. 22-gauge cold-rolled steel (C.R.S.) outer and inner panels are sandwiched together, spot welded and TIG welded to form a rigid assembly. Standard Ruckus pulls (beveled pulls) are cast zinc and are installed on the top face of each door. Pulls mount by use of two machine screws to the steel door. Pulls are available in satin chrome or powder-coat painted black finish. 110° European hinges prevent the doors from contacting an adjacent cabinet door or drawer and provide 3-way adjustment.

Locks

Locks are included on every door:

Standard Key Lock (comes with pull option only) - The standard lock is a high-security double-bit lock core. The double-bit lock offers superior security when compared to a single-bit lock. Units are standard with random keys in a range of 994 different numbers. Standard locks are available with satin chrome or black powder-coat finishes. Specific keying combinations are available at no additional charge (this information must be included with order). Specific keyed locks are available only with black powder-coat finish. Locks can be master keyed.

Finish

Units are offered in numerous powder-coat colors. Powder-coat application is a hybrid epoxy, baked on to provide a scratch and stain resistant finish. Shells and doors may be specified in separate colors for no upcharge. Mechanical components are plated or finished with other protective coatings.



TECHNICAL SPECIFICATIONS

Tote Storage Configurations

Ruckus Tote Storage is comprised of four different size enclosures, on casters or glides, with or without doors. Each of these unit heights and look can be changed by including the optional 1 1/4" laminated wood worksurface. Three preconfigured options are available: All 3" totes, all 6" totes or a combination of 3" & 6" totes. Illustrated below are the 30" wide 2-column units, 44" wide, 3-column units are also available.

Tote storage is available in two heights, allowing configuration heights of either 18" or 27".

Preconfigured Options:

Short Storage Unit

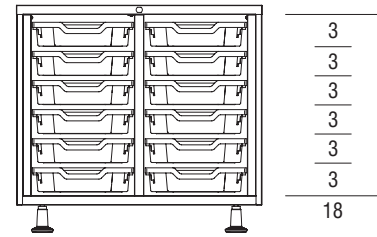

Tall Storage Unit

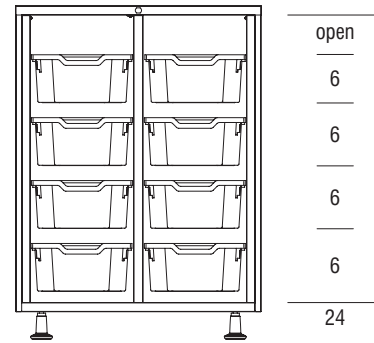
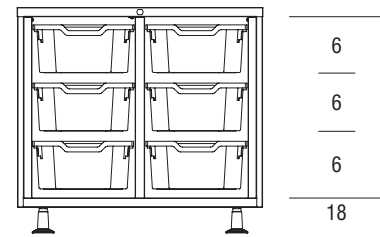
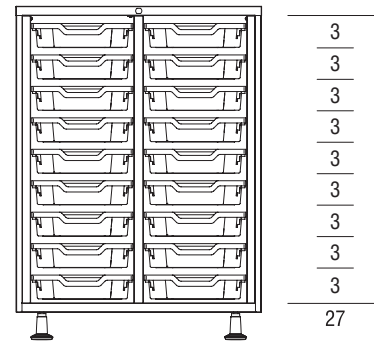

Note: There is 3" of tote storage space open at the top of each column of the tall storage unit (42" high) when pre-configured with 6" totes.

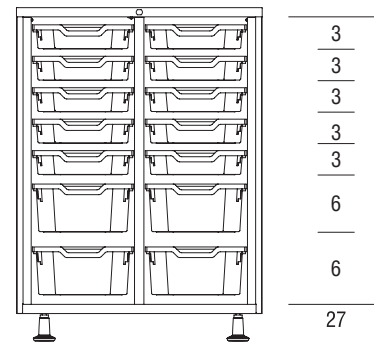
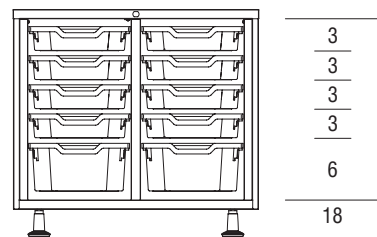

TECHNICAL SPECIFICATIONS

Tote Storage Configurations (cont.)

Ruckus Tote Storage, in any tote configuration beyond the preconfigured options, must be ordered separately and installed on site. The 3", 6", 9" and 12" high totes can be ordered in kits with a quantity of six totes (rail sets included), and can be programmed into any empty or pre-existing Ruckus tote storage units, without the use of tools.

Shown below are two examples of non-preconfigured layouts. Customers can specify any combination of totes as long as their accumulated heights do not exceed 18" per column for Short Tote Storage units, and do not exceed 27" per column for Tall Tote Storage units.

Build Your Own Examples:

Short Storage Unit

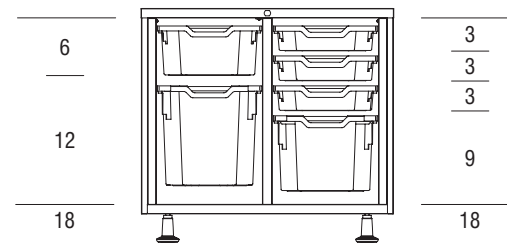

Tall Storage Unit

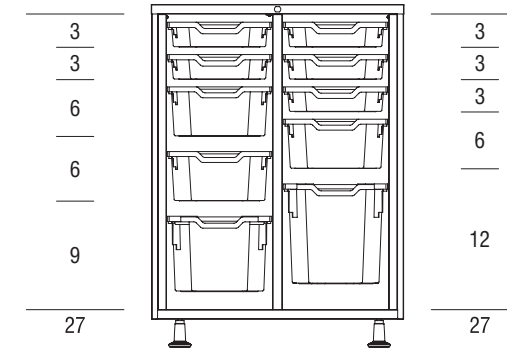

DIMENSIONS

General Dimensions - Totes			
	A (Height)	B (Width)	C (Depth)
3"	2 ¹⁵ / ₁₆ "	12 ¹ / ₄ "	16 ³ / ₄ "
6"	5 ⁷ / ₈ "	12 ¹ / ₄ "	16 ³ / ₄ "
9"	8 ¹⁵ / ₁₆ "	12 ¹ / ₄ "	16 ³ / ₄ "
12"	11 ⁷ / ₈ "	12 ¹ / ₄ "	16 ³ / ₄ "

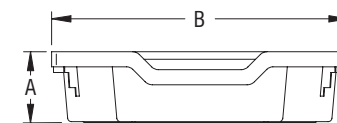

Front View

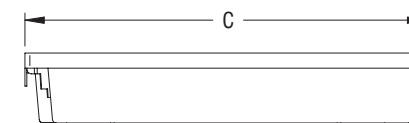

Side View



DIMENSIONS

General Dimensions - Tote Storage Without Laminate Top				
	A (Height)	B (Width)	C (Depth)	D (Door Pull-to-Back)
Tote Storage, Short, 2-Compartment Unit	27 ¹⁵ / ₁₆ "	30 ¹ / ₈ "	18 ¹ / ₈ "	18 ¹³ / ₁₆ "
Tote Storage, Short, 3-Compartment Unit	27 ¹⁵ / ₁₆ "	43 ¹⁵ / ₁₆ "	18 ¹ / ₈ "	18 ¹³ / ₁₆ "
Tote Storage, Tall, 2-Compartment Unit	40 ¹⁵ / ₁₆ "	30 ¹ / ₈ "	18 ¹ / ₈ "	18 ¹³ / ₁₆ "
Tote Storage, Tall, 3-Compartment Unit	40 ¹⁵ / ₁₆ "	43 ¹⁵ / ₁₆ "	18 ¹ / ₈ "	18 ¹³ / ₁₆ "

General Dimensions - Tote Storage With Laminate Top				
	A (Height)	B (Width)	C (Depth)	D (Door Pull-to-Back)
Tote Storage, Short, 2-Compartment Unit, with Laminate Top	29 ³ / ₁₆ "	30 ¹ / ₄ "	18 ¹ / ₄ "	18 ¹³ / ₁₆ "
Tote Storage, Short, 3-Compartment Unit, with Laminate Top	29 ³ / ₁₆ "	44 ¹ / ₁₆ "	18 ¹ / ₄ "	18 ¹³ / ₁₆ "
Tote Storage, Tall, 2-Compartment Unit, with Laminate Top	42 ³ / ₁₆ "	30 ¹ / ₄ "	18 ¹ / ₄ "	18 ¹³ / ₁₆ "
Tote Storage, Tall, 3-Compartment Unit, with Laminate Top	42 ³ / ₁₆ "	44 ¹ / ₁₆ "	18 ¹ / ₄ "	18 ¹³ / ₁₆ "

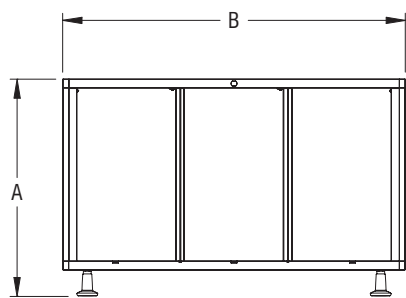

Front View

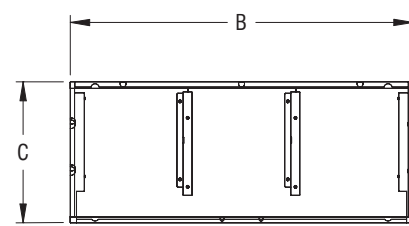

Top View

STATEMENT OF LINE

Ruckus Single-Face Tote Storage

Tote storage is available with optional pre-loaded configurations of 3", 6" and 3" & 6" high totes. Tote storage is available with and without laminate worksurface, and with and without doors.

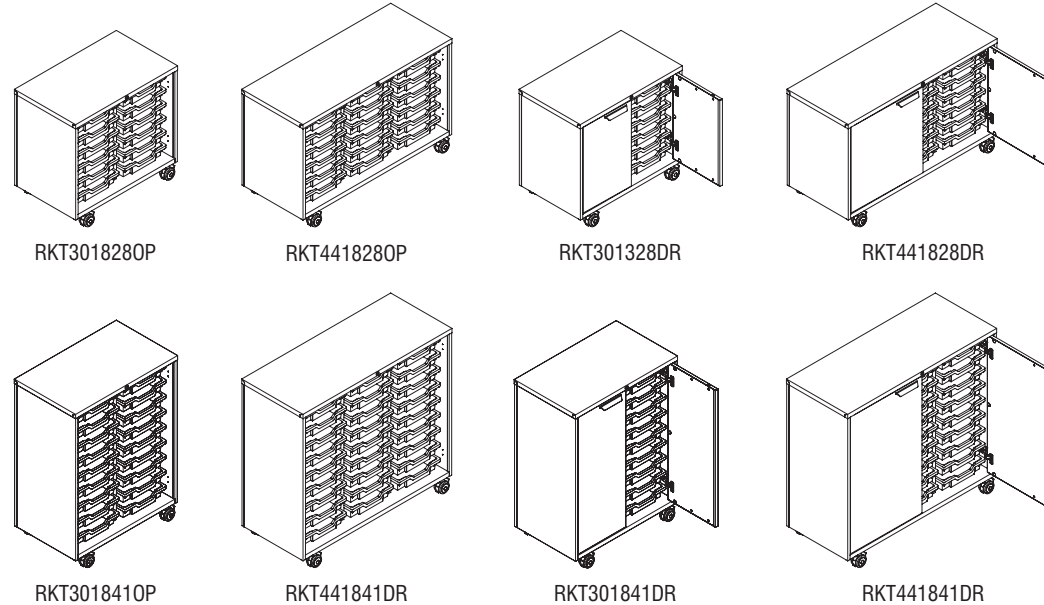

Accessories

Accessory Totes and lids are sold in packages of six only. Lids must be ordered separately.

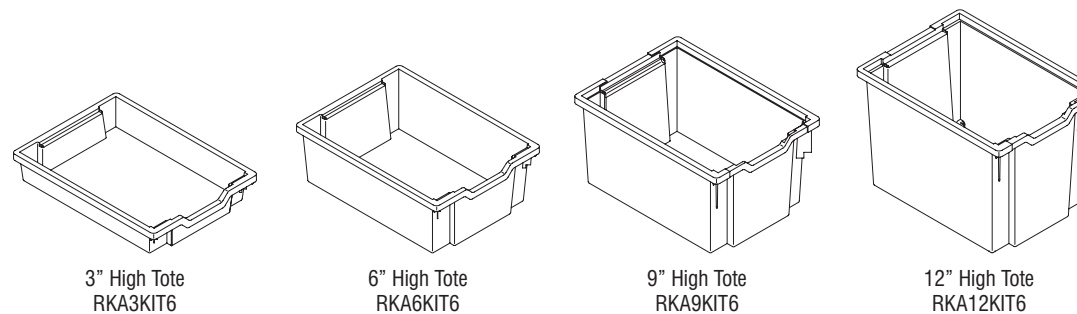

3" High Tote
RKA3KIT6

6" High Tote
RKA6KIT6

9" High Tote
RKA9KIT6

12" High Tote
RKA12KIT6

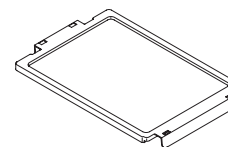

Tote Storage Lid
RKALIDKIT6

Undersurface Rail Kit, with 3" Tote

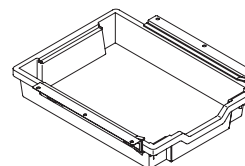

RKAUSR3TKIT1

Undersurface Rail Kit (tote specified separately)

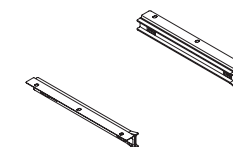

RKAUSRKIT1



Shell Color		Raw Jasper	RJ	Designer White	LDR	Fawn Cypress	EFQ
Black	BL	Rubber Ducky	RK	Dove Grey	LDG	Flannel	EFN
Blue Grey	GR	Sand	SA	Florence Walnut	LFC	Florence Walnut	EFC
Bronze Metallic	ZM	Sky Blue	SK	Friston Ash	LFH	Friston Ash	EFH
Cayenne	CY	Starlight Silver Metallic	SX	Frosty White	LFW	Frosty White	EFW
Champagne Metallic	CM	Surf's Up	SP	Graphite Nebula	LGN	Hartley Walnut	EHW
Cool Grey	CG	Tarragon	TQ	Grey	LGE	Hazy Jade	EHJ
Cottonwood	CO	Twilight Shadow	TI	High Rise	LHE	Italian Silver Ash	EIT
Earthen Clay	EY	Ultra Blue	UB	Hollyberry	LHY	Kensington Maple	EKM
Espresso Metallic	EX	Warm Grey	WG	Island	LID	Light Tone	ELG
Everglade Shade	EV	Zesty Lime	ZL	Italian Silver Ash	LIT	Mardi Gras	EMG
Flannel	FN			Kensington Maple	LKM	Misty Brown	EMY
Glitz Metallic	GZ	Front Door Color		Lapis Blue	LLB	Monticello Maple	EMT
Hazy Jade	HJ	Black	FBL	Monticello Maple	LMT	Multiplex	EMB
Honey Bee	HY	Blue Grey	FGR	North Sea	LNA	Nemo	ENE
Light Tone	LG	Bronze Metallic	FZM	Ocean	LON	Nordic	END
Mardi Gras	MG	Cayenne	FCY	Pinnacle Walnut	LPW	Pinnacle Walnut	EPW
Misty Brown	MY	Champagne Metallic	FCM	River Cherry	LRY	Poppy Red	EPR
Nemo	NE	Cool Grey	FCG	Shadow Zephyr	LSR	Rainforest	ERQ
Nordic	ND	Cottonwood	FCO	Sterling Ash	LAZ	Raleigh Walnut	ERW
Poppy Red	PR	Earthen Clay	FEY	Titanium Evolv	LTV	River Cherry	ERY
Purple Haze	PH	Espresso Metallic	FEX	White Nebula	LWL	Rubber Ducky	ERK
Rainforest	RQ	Everglade Shade	FEV	White Sand	LWN	Sand	ESA
Raw Jasper	RJ	Flannel	FFN	Windsor Mahogany	LWY	Sky Blue	ESK
Rubber Ducky	RK	Glitz Metallic	FGZ			Solano Walnut	ESG
Sand	SA	Hazy Jade	FHJ			Sterling Ash	EAZ
Sky Blue	SK	Honey Bee	FHY	*Additional colors may be available. Please contact KI customer service at 1-800-424-2432		Surf's Up	ESP
Starlight Silver Metallic	SX	Light Tone	FLG			Tarragon	ETQ
Surf's Up	SP	Mardi Gras	FMG	Surface Finish--Grade 2 Standard Laminate		Twilight Shadow	ETI
Tarragon	TQ	Misty Brown	FMY	Akira	LAK	Ultra Blue	EUB
Twilight Shadow	TI	Nemo	FNE	Black Alicante	LBY	Valley Forge Elm	EVF
Ultra Blue	UB	Nordic	FND	Black Hills Oak	LBH	Warm Grey	EWG
Warm Grey	WG	Poppy Red	FPR	Calcutta Marble	LCQ	White River Forest	EWR
Zesty Lime	ZL	Purple Haze	FPH	Dering Forest	LDF	Windsor Mahogany	EWY
		Rainforest	FRQ	Fawn Cypress	LFQ	Zesty Lime	EZL
		Raw Jasper	FRJ	Ice Mist	LIM		
Removeable Steel Shelf Color		Rubber Ducky	FRK	Markerboard White	LMK	Pull Color	
Black	BL	Rubber Ducky	FRK	Markerboard White	LMK	Beveled pull Satin Chrome	S5
Blue Grey	GR	Sand	FSA	Valley Forge Elm	LVF	Beveled pull Black	S6
Bronze Metallic	ZM	Sky Blue	FSK	White River Forest	LWR		
Cayenne	CY	Starlight Silver Metallic	FSX			Tote Storage Lock Color	
Champagne Metallic	CM	Surf's Up	FSP	Edge Color-For 74P Edge		Black	BLL
Cool Grey	CG	Tarragon	FTQ	Akira	EAK	Satin Chrome	SCL
Cottonwood	CO	Twilight Shadow	FTI	Beigewood	EBZ		
Earthen Clay	EY	Ultra Blue	FUB	Belair	EBQ		
Espresso Metallic	EX	Warm Grey	FWG	Biltmore Cherry	EBT		
Everglade Shade	EV	Zesty Lime	FZL	Black	EBL		
Flannel	FN			Black Hills Oak	EBH		
Glitz Metallic	GZ	Surface Finish--Grade 1 Standard Laminate		Blue Grey	EGR		
Hazy Jade	HJ	Beigewood	LBZ	Brighton Walnut	EBW		
Honey Bee	HY	Belair	LBQ	Castle Oak	ECO		
Light Tone	LG	Biltmore Cherry	LBT	Cayenne	ECY		
Mardi Gras	MG	Black	LBK	Cherry Storm	ECX		
Misty Brown	MY	Brighton Walnut	LBW	Cocobala	ECC		
Nemo	NE	Castle Oak	LCO	Cool Grey	ECG		
Nordic	ND	Cherry Storm	LCX	Cumberland Walnut	ECJ		
Poppy Red	PR	Classic Linen	LCI	Dering Forest	EDF		
Purple Haze	PH	Cocobala	LCC	Designer White	EDR		
Rainforest	RQ	Crisp Linen	LRI	Everglade Shade	EEV		

Finish Cards

View color swatches for items listed within this document.

- Paints
- Wood/Veneer
- Molded Edges
- Hard Plastics
- Plastics/Poly
- Laminates
- Edge Styles
- Glass

Certain options referenced may not be available on GSA Schedule.



PRODUCT SPECIFICATIONS ■

Ruckus® Whiteboards & Accessories

February 2026

TECHNICAL SPECIFICATIONS

Ruckus Whiteboard

Dry-Erase Whiteboard (Side 1)

Dry-erase whiteboard surface is constructed of .08" thick opaque white polycarbonate resin with UV curing.

Polyester Felt (Side 2)

Polyester felt is constructed from 16 mm thick tackable, 100% post-consumer recycled polyester core felt in the color Flannel. The core material has a density of 2800 g/m² and is sound absorbing tested to ASTM C423 with an NRC rating of 0.55 when using no air gap (A-mount testing method) and an NRC rating of 0.60 with a 5 mm air gap. The polyester felt is in accordance with ASTM-E84 and achieve a Class A Flame spread.

Extra large whiteboards are constructed with two aluminum extruded stiffeners.

Magnetic Dots (Fasteners)

Securing the whiteboard to the polyester felt core material are two 1/4-28 x 5/8" and two 1/4-28 x 3/4" metallic socket flat head screws through custom nylon 1/4" countersunk washers, threading into 1/4-28 nylon nuts at the backside of the felt core material. The flat heads of the metallic fasteners may be used to attach customer supplied magnetic accessories.

Leather Straps

Constructed of reconstituted (bonded) leather in matte black. Straps are 1.16" wide and permit hanging of Ruckus whiteboards on wall tracks and mobile display carts.

Pivoting Dock

Pivoting dock assembly consists of a table clamp and a whiteboard clamp, constructed of 14-gauge steel and secured with a screw that allows for 360 degrees of rotation. Whiteboard clamp is covered in a protective black plastic coating. Two thumb screw sizes are provided to clamp to different worksurface thicknesses. The 3/4" thumb screw will accommodate worksurface thicknesses from 3/4" to 1 1/4". The 1 1/4" thumb screw will accommodate thicknesses from 1/4" to 1 1/16". Steel pivoting dock is powder-coat painted in black only.

Wall Track

Wall track rail is formed of 16-gauge steel, powder-coat painted in various standard KI finishes. 48" wide and holds one to three white boards depending on size. Attachment hardware not included. Reference (KI-AI-000098) Ruckus Whiteboards - Wall Track - Assembly Instructions for more information.

Mobile Display Cart

Mobile display cart is constructed with 1" diameter, 13-gauge steel tubing, bent, cut, welded and secured with fasteners. The side panels and inner shelf are constructed of 14-gauge steel, stamped and formed. All steel components are powder-coat painted in Starlight Silver. Storage section on the cart contains a non-skid pad. Available with two optional polypropylene 6" tote storage drawers.

Casters

Mobile display cart ships with four locking casters with hard plastic wheels. Caster wheel height is 3", overall mounting height is 4", and caster unit is black. Caster bodies include a 7/16" x 7/8" grip-ring stem, which inserts into a grip-ring adapter in the legs of the mobile display cart. Casters are field replaceable.

Widget

Widget is constructed from 16 mm thick, 100% post-consumer recycled polyester felt in the color Flannel.

Undersurface Hook

Undersurface hook is formed from 1/4" solid wire rod and is chrome plated, which provides long lasting wear resistance. Hook fastens to the underside of the worksurface with two #12 x 3/4" Phillips pan-head screws. Hook is field installed.

TECHNICAL SPECIFICATIONS

Ruckus Whiteboard & Mobile Display Cart Capacity

Size	Display Capacity	Storage Capacity	Total Capacity
Small	12	39	51
Medium	8	24	32
Large	4	18	22
Extra Large	4	11	15

Note: display cart shelves are deep enough to store an additional row of whiteboards behind boards being displayed.

Ruckus Whiteboard & Wall Track Capacity

Size	Wall Track (Qty 1) (48" length)	Wall Tracks (Qty 2) (96" length)
Small	3	6
Medium	2	4
Large	1	3
Extra Large	2 vertical, 1 horizontal	4 vertical, 1 horizontal

VISUAL GUIDE

Ruckus Whiteboards & Wall Track Strap Engagement

Leather straps on the back of Ruckus whiteboards are designed to allow the board to hang from the wall track. The straps wrap around to the front, making them useful to hold paper notes.

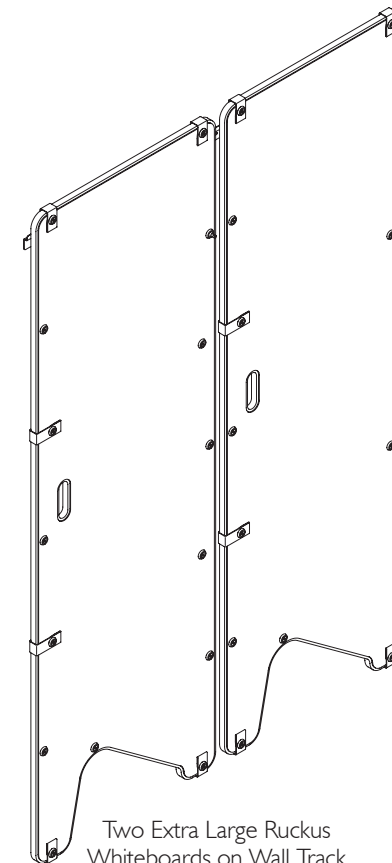

Two Extra Large Ruckus Whiteboards on Wall Track

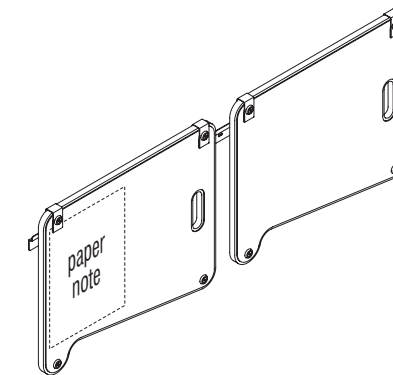

Two Medium Ruckus Whiteboards on Wall Track

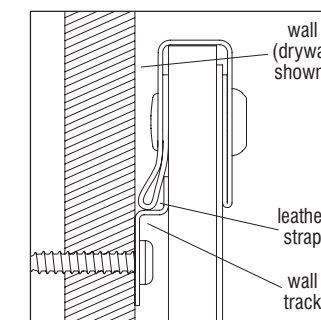

Strap Engagement - (side view)

VISUAL GUIDE
Ruckus Whiteboards & Ruckus Mobile Display Cart Track Strap Engagement

Leather straps on the back of Ruckus whiteboards are designed to allow the board to hang from the Ruckus mobile display kart track. The straps wrap around to the front, making them useful to hold paper notes.

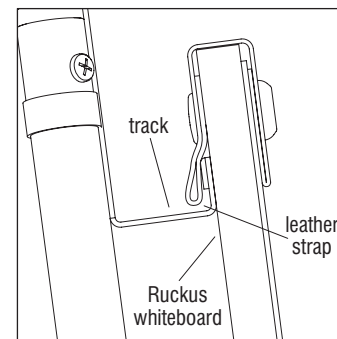
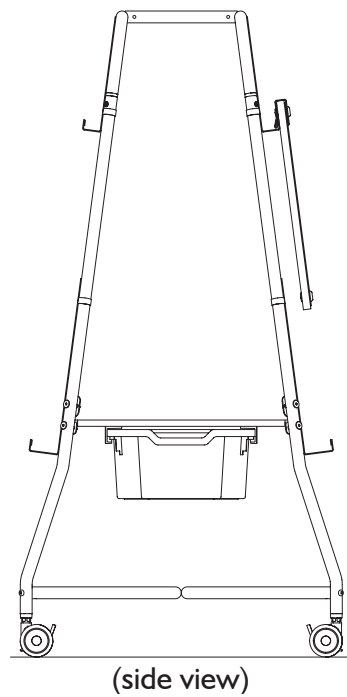
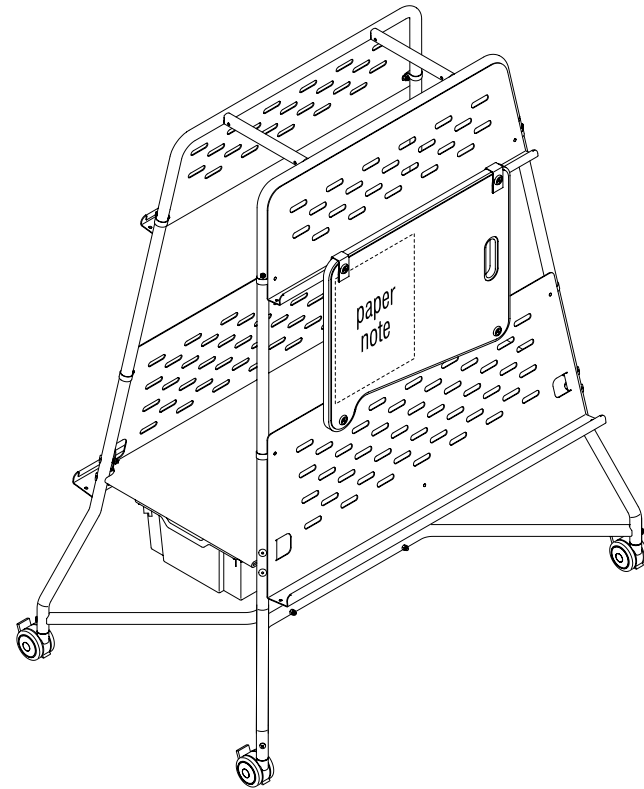

Strap Engagement - (side view)

VISUAL GUIDE
Ruckus Whiteboard & Pivoting Dock

Pivoting dock allows small, medium and large Ruckus whiteboard to rotate 360 degrees on the table or student desk.

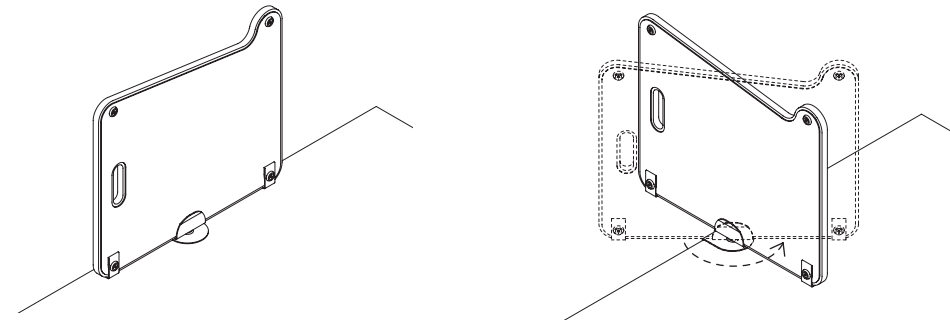

Ruckus Whiteboard & Undersurface Hook

Small and Medium sized Ruckus whiteboards that are not in use can be stored on optional undersurface hooks. Ruckus post-leg desks and rectangle activity tables (excluding 20" deep tables) come with pre-drilled locations for installing undersurface hooks.

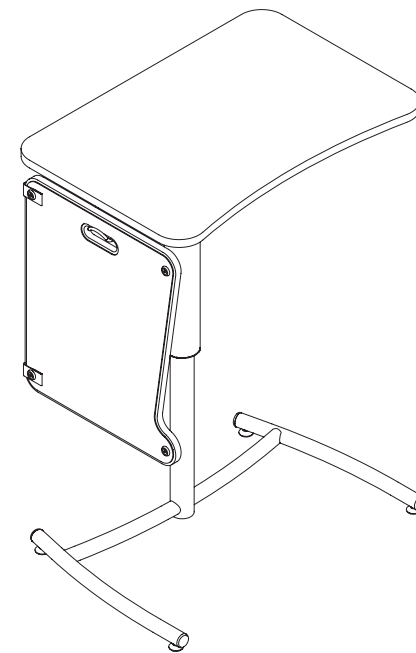
Note: Undersurface hooks cannot be installed on Ruckus cantilever desks and lecterns when book basket storage is specified, or on 20" deep rectangle activity tables. Contact KI customer service at 1-800-424-2432 for other undersurface hook solutions.

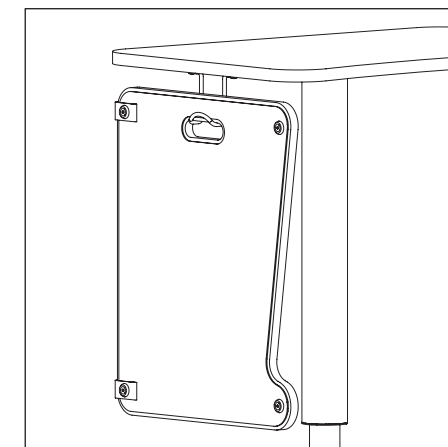

Undersurface Hook



Undersurface Hook



VISUAL GUIDE

Ruckus Whiteboard & Widget

Widgets are a multi-functional accessory that pair with Whiteboards to enhance use and support multiple configurations. Widgets can help to create a stand for display or drafting, and they are useful to create dividers or privacy screens. In addition, each Widget can hold one standard size dry-erase marker (approximately 1 1/16" diameter) or two smaller sized dry-erase markers (approximately 3/8" diameter).

Note: The graphics on this page illustrate markers being housed in the marker holder feature of the widgets. Dry-erase markers are customer supplied.

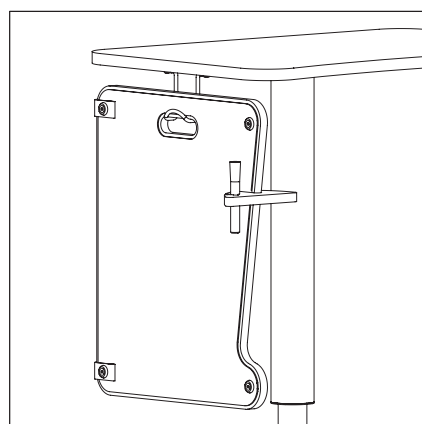

Widget used as a Marker Holder

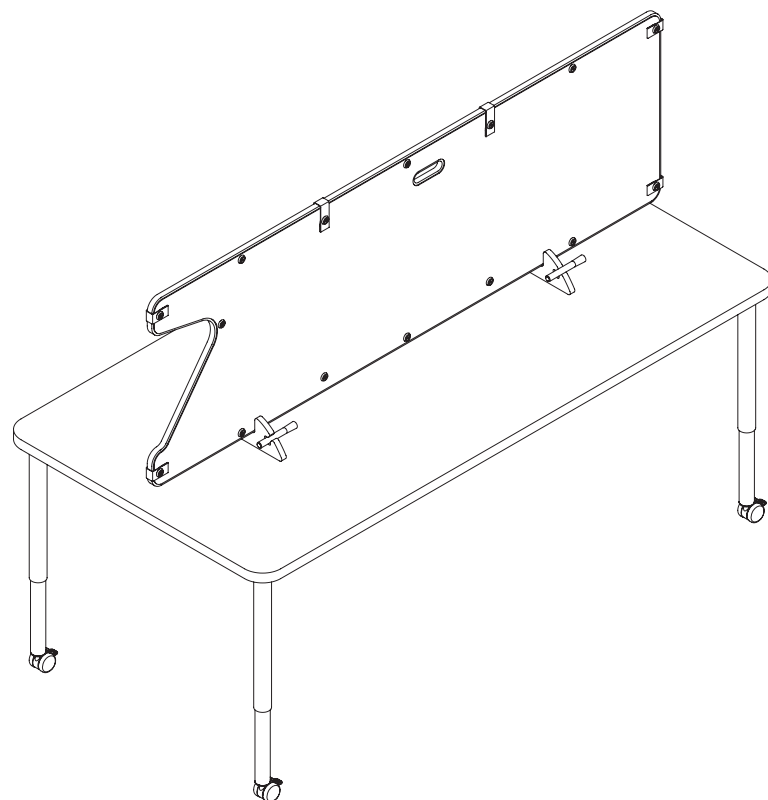

Display & Divider Configuration

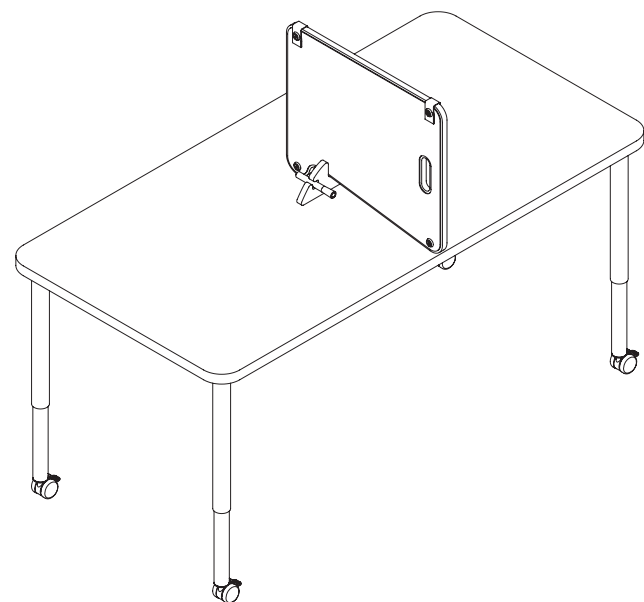

Display & Privacy Configuration

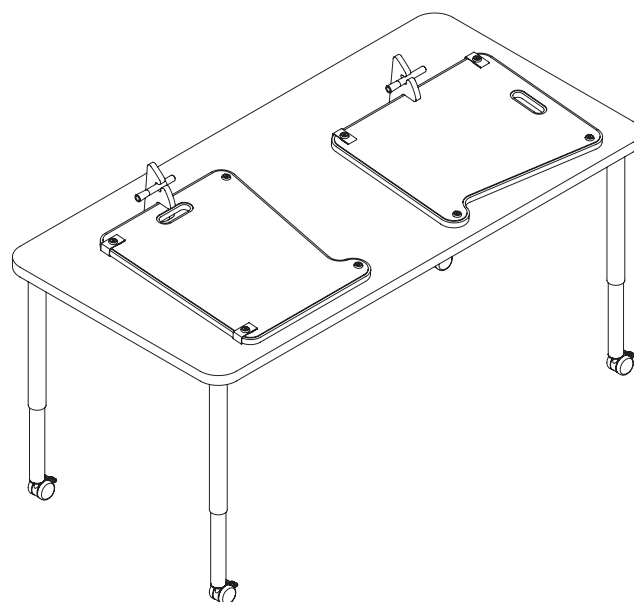

Drafting Configuration

DIMENSIONS

Ruckus Whiteboard - Small (12" x 16")

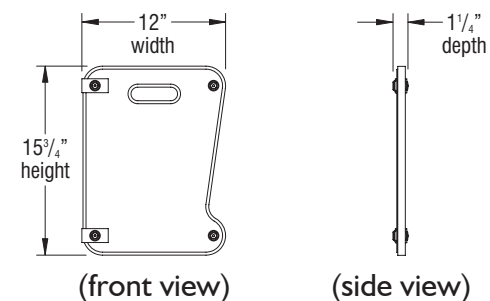

Ruckus Whiteboard - Medium (18" x 22")

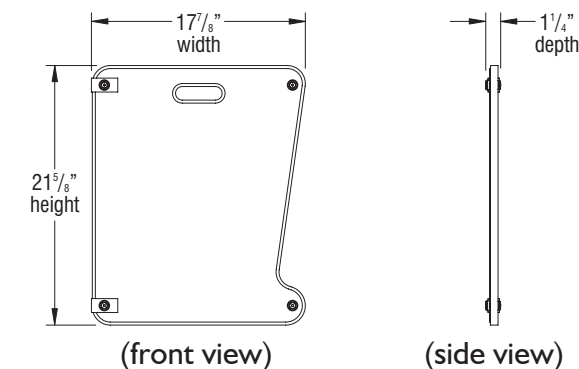

Ruckus Whiteboard - Large (23" x 31")

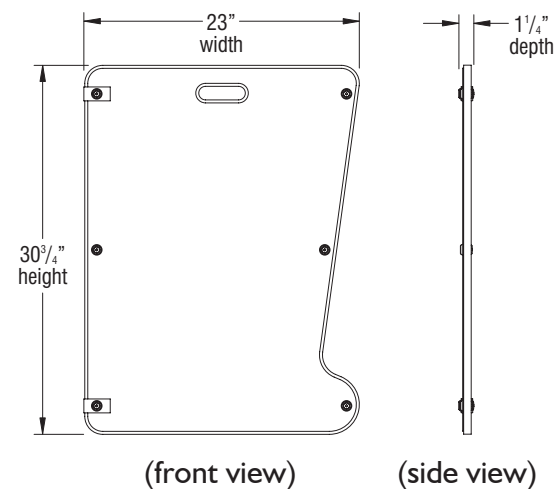

Ruckus Whiteboard - Extra Large (23" x 71")

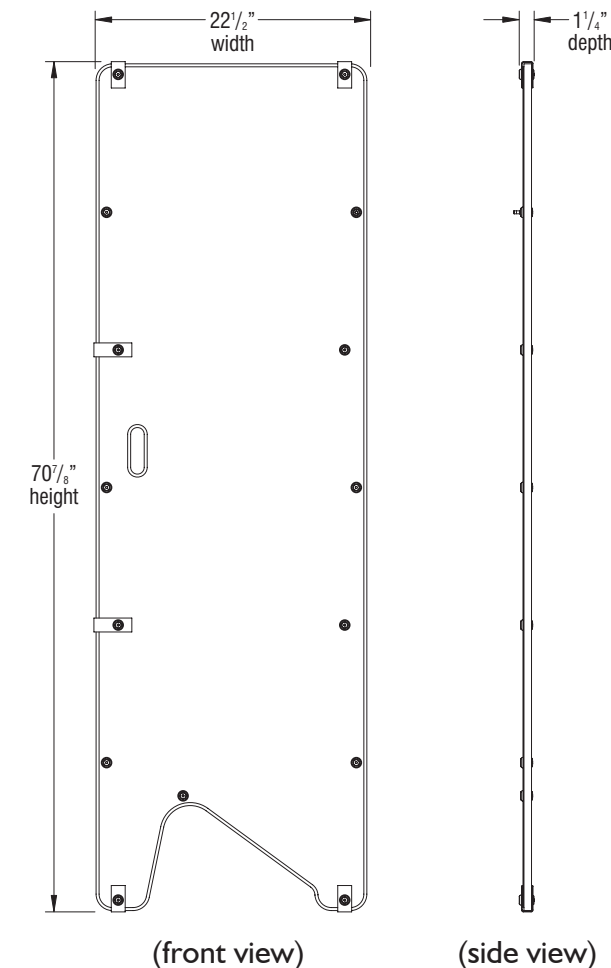



DIMENSIONS

Ruckus Mobile Display Cart

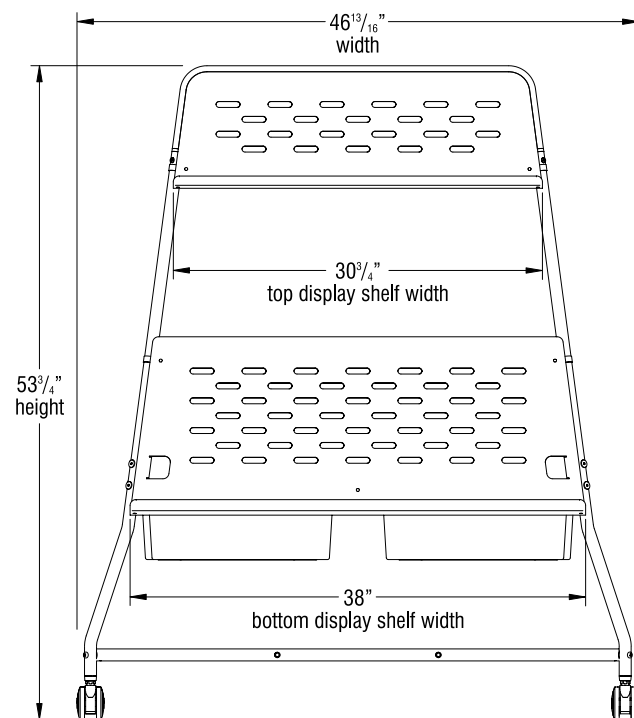

(front view)

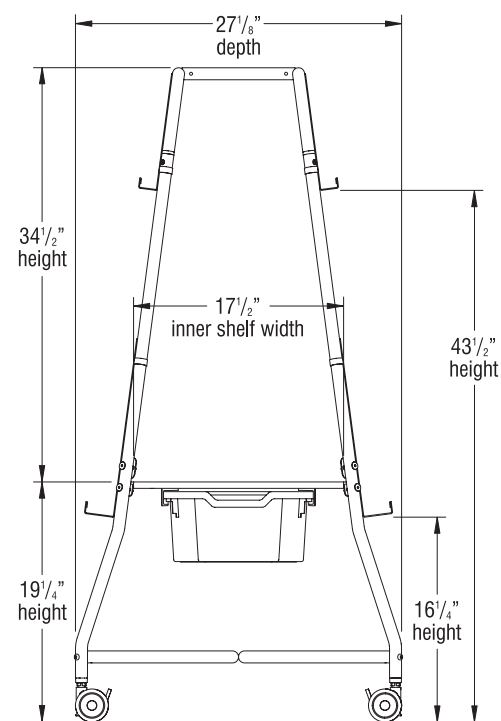

(side view)

STATEMENT OF LINE

Ruckus Whiteboards



Small (12 x 16")
RKWB1612

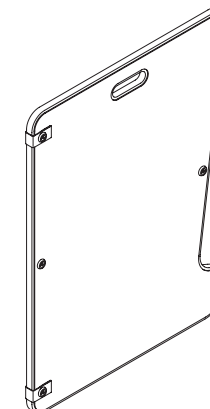

Large (23 x 31")
RKWB3123

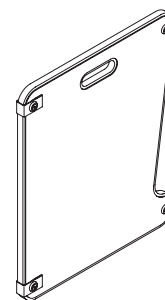

Medium (18 x 22")
RKWB2218

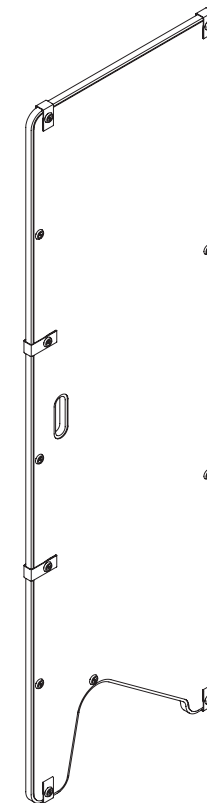

Extra Large (23 x 71")
RKWB7123

Ruckus Whiteboard Accessories

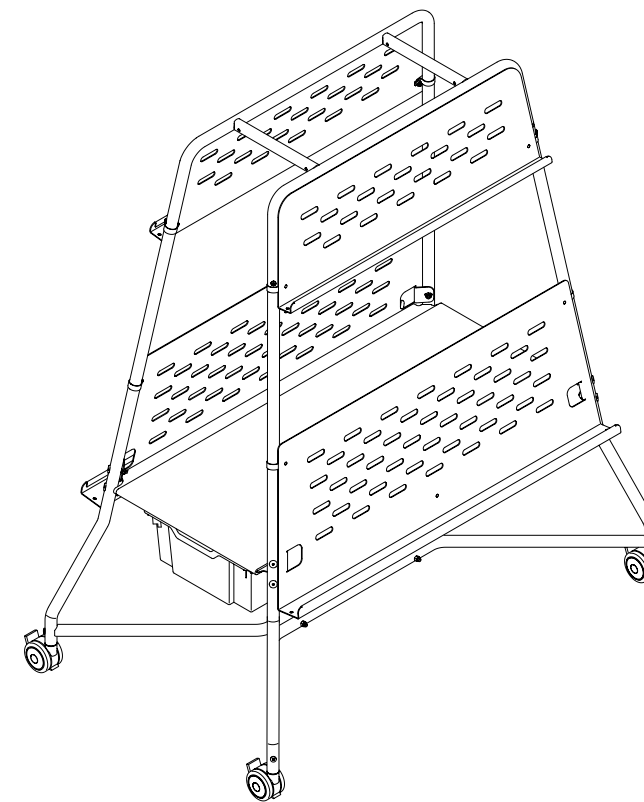

Mobile Display Cart
RKWACART

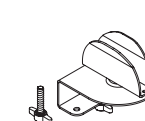

Pivoting Dock
RKWADOCK

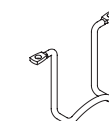

Undersurface Hook
RKWMUSHOOK

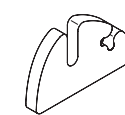

Widget
RKWAWIDGET

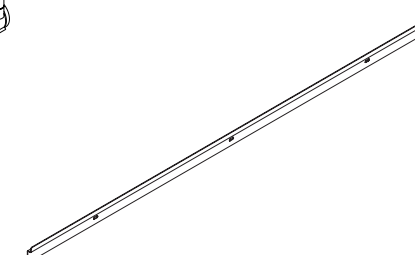

48" Wall Track
RKWAWALLTRCK



Wall Track

Black	BL
Blue Grey	GR
Bronze Metallic	ZM
Cayenne	CY
Champagne Metallic	CM
Cool Grey	CG
Cottonwood	CO
Earthen Clay	EY
Espresso Metallic	EX
Everglade Shade	EV
Flannel	FN
Glitz Metallic	GZ
Hazy Jade	HJ
Honey Bee	HY
Light Tone	LG
Mardi Gras	MG
Misty Brown	MY
Nemo	NE
Nordic	ND
Poppy Red	PR
Purple Haze	PH
Rainforest	RQ
Raw Jasper	RJ
Rubber Ducky	RK
Sand	SA
Sky Blue	SK
Starlight Silver Metallic	SX
Surf's Up	SP
Tarragon	TQ
Twilight Shadow	TI
Ultra Blue	UB
Warm Grey	WG
Zesty Lime	ZL

Whiteboard Mobile Display Cart

Starlight Silver Metallic	SX
---------------------------	----

Undersurface Hook

Chrome	C
--------	---

Pivoting Dock

Black	BL
-------	----

Finish Cards

View color swatches for items listed within this document.

[Paints](#)

[Plastics/Poly](#)

[Wood/Veneer](#)

[Laminates](#)

[Molded Edges](#)

[Edge Styles](#)

[Hard Plastics](#)

[Glass](#)

Certain options referenced may not be available on GSA Schedule.



Ruckus® Seating (Freight Excluded Pricing)

Four-Leg Chair



Ruckus® Seating (Freight Excluded Pricing)

Four-Leg Chair

MODEL	Features	H	MODEL NUMBER					Approx. Packaged Weight	Freight Excluded Pricing Unupholstered	Freight Excluded Pricing Fabric Grade 1 & C.O.M.	Freight Excluded Pricing Fabric Grade 2	Freight Excluded Pricing Fabric Grade 3 & Group 2V Vinyl	Freight Excluded Pricing Pallas Fabric Group P0	Freight Excluded Pricing Pallas Fabric Group P1	Freight Excluded Pricing Pallas Fabric Group P2	Freight Excluded Pricing Pallas Fabric Group P3	Freight Excluded Pricing Pallas Fabric Group P4	
			Basic Model	Poly Color	Frame Color	Glide Option	Upholstery Color											
 <p>Four-Leg Chair with Glides</p> <ul style="list-style-type: none"> Model does not stack Ships fully assembled, packaged 1 chair per carton 	Polypropylene	15"	RK1100H15NB	<input type="checkbox"/> <input type="checkbox"/> <input type="checkbox"/>	<input type="checkbox"/> <input type="checkbox"/>	<input type="checkbox"/> <input type="checkbox"/> <input type="checkbox"/>		29.00#	\$ 230									
	Polypropylene	18"	RK1100H18NB	<input type="checkbox"/> <input type="checkbox"/> <input type="checkbox"/>	<input type="checkbox"/> <input type="checkbox"/>	<input type="checkbox"/> <input type="checkbox"/> <input type="checkbox"/>		30.00#	232									
RK11	 <p>Four-Leg Chair with Glides</p> <ul style="list-style-type: none"> Model does not stack Ships fully assembled, packaged 1 chair per carton 	Upholstered Seat	15"	RK1200H15NB	<input type="checkbox"/> <input type="checkbox"/> <input type="checkbox"/>	<input type="checkbox"/> <input type="checkbox"/>	<input type="checkbox"/> <input type="checkbox"/> <input type="checkbox"/>	<input type="checkbox"/> <input type="checkbox"/> <input type="checkbox"/> <input type="checkbox"/> <input type="checkbox"/>	31.50#	N/A	\$ 362	\$ 373	\$ 393	\$ 406	\$ 473	\$ 493	\$ 518	\$ 555
		Upholstered Seat	18"	RK1200H18NB	<input type="checkbox"/> <input type="checkbox"/> <input type="checkbox"/>	<input type="checkbox"/> <input type="checkbox"/>	<input type="checkbox"/> <input type="checkbox"/> <input type="checkbox"/>	<input type="checkbox"/> <input type="checkbox"/> <input type="checkbox"/> <input type="checkbox"/> <input type="checkbox"/>	32.50#	N/A	364	375	398	410	475	495	522	558
RK12																		

A B C D E

HOW TO ORDER

- Indicate the following information on order form:
- Quantity of each item.
 - Model number, including options. See "How To Build a Model Number".
 - Any special service required.

Note:

- The indicates that a choice is required.
- The absence of the indicates that no choice is required.
- Alpha-numeric characters in place of indicate that no other alternatives are available.

HOW TO BUILD A MODEL NUMBER

- A** Select basic model.
- B** Select poly color. Refer to the **Product Color Options** page in this price list.
- C** Select frame finish. Refer to the **Product Color Options** page in this price list.
- D** Select glide option.

GFT	- Felt glides
GPL	- Nylon plastic glides
GSL	- Steel glides
- E** Select upholstery grade/color. Refer to ki.com/fabrics

UPHOLSTERY INFORMATION

C.O.M. Upholstery
 C.O.M. requirement for 10 chairs or less with upholstered seat or upholstered seat and back is 3/4 yard per chair of 54" wide nondirectional fabric. For orders of 11 or more with upholstered seat and back and for complete information on ordering C.O.M. see "Ordering C.O.M., C.O.V. and C.O.L." section.

SPECIAL SERVICES

Special Carton Marking

With specially marked information N/C

Shipping

Ships assembled, FOB Green Bay, WI 54302, freight excluded. Freight class 250.

Specifications and prices are subject to change without prior notice.



Ruckus® Seating (Freight Excluded Pricing)

Four-Leg Chair



Ruckus® Seating (Freight Excluded Pricing)

Four-Leg Chair

MODEL	Features	H	MODEL NUMBER					Approx. Packaged Weight	Freight Excluded Pricing Unupholstered	Freight Excluded Pricing Fabric Grade 1 & C.O.M.	Freight Excluded Pricing Fabric Grade 2	Freight Excluded Pricing Fabric Grade 3 & Group 2V Vinyl	Freight Excluded Pricing Pallas Fabric Group P0	Freight Excluded Pricing Pallas Fabric Group P1	Freight Excluded Pricing Pallas Fabric Group P2	Freight Excluded Pricing Pallas Fabric Group P3	Freight Excluded Pricing Pallas Fabric Group P4	
			Basic Model	Poly Color	Frame Color	Caster Type	Upholstery Color											
 Four-Leg Chair with Casters • Model does not stack • Ships fully assembled, packaged 1 chair per carton	Polypropylene	15"	RK2100H15NB	<input type="checkbox"/> <input type="checkbox"/> <input type="checkbox"/>	<input type="checkbox"/> <input type="checkbox"/>	<input type="checkbox"/> <input type="checkbox"/> <input type="checkbox"/>		29.50#	\$ 245									
	Polypropylene	18"	RK2100H18NB	<input type="checkbox"/> <input type="checkbox"/> <input type="checkbox"/>	<input type="checkbox"/> <input type="checkbox"/>	<input type="checkbox"/> <input type="checkbox"/> <input type="checkbox"/>		30.50#	247									
RK21	 Four-Leg Chair with Casters • Model does not stack • Ships fully assembled, packaged 1 chair per carton	Upholstered Seat	15"	RK2200H15NB	<input type="checkbox"/> <input type="checkbox"/> <input type="checkbox"/>	<input type="checkbox"/> <input type="checkbox"/>	<input type="checkbox"/> <input type="checkbox"/> <input type="checkbox"/>	<input type="checkbox"/> <input type="checkbox"/> <input type="checkbox"/> <input type="checkbox"/>	32.00#	N/A	\$ 376	\$ 389	\$ 412	\$ 421	\$ 488	\$ 507	\$ 534	\$ 572
		Upholstered Seat	18"	RK2200H18NB	<input type="checkbox"/> <input type="checkbox"/> <input type="checkbox"/>	<input type="checkbox"/> <input type="checkbox"/>	<input type="checkbox"/> <input type="checkbox"/> <input type="checkbox"/>	<input type="checkbox"/> <input type="checkbox"/> <input type="checkbox"/> <input type="checkbox"/>	33.00#	N/A	380	391	414	426	490	513	537	574
RK22																		

A **B** **C** **D** **E**

HOW TO ORDER

- Indicate the following information on order form:
- Quantity of each item.
 - Model number, including options. See "How To Build a Model Number".
 - Any special service required.

Note: • The indicates that a choice is required.
 • The absence of the indicates that no choice is required.
 • Alpha-numeric characters in place of indicate that no other alternatives are available.

HOW TO BUILD A MODEL NUMBER

- A** Select basic model.
- B** Select poly color. Refer to the **Product Color Options** page in this price list.
- C** Select frame finish. Refer to the **Product Color Options** page in this price list.
- D** Select caster type.
CCC - Carpet casters
CHC - Hard floor casters
- E** Select upholstery grade/color. Refer to ki.com/fabrics

UPHOLSTERY INFORMATION

C.O.M. Upholstery
 C.O.M. requirement for 10 chairs or less with upholstered seat or upholstered seat and back is 3/4 yard per chair of 54" wide nondirectional fabric. For orders of 11 or more with upholstered seat and back and for complete information on ordering C.O.M. see "Ordering C.O.M., C.O.V. and C.O.L." section.

SPECIAL SERVICES

Special Carton Marking

With specially marked information N/C

Shipping

Ships **assembled, FOB Green Bay, WI 54302, freight excluded.** Freight class 250.

Specifications and prices are subject to change without prior notice.



Ruckus® Seating (Freight Excluded Pricing)

Stack Chair with Glides



Ruckus® Seating (Freight Excluded Pricing)

Stack Chair with Glides

MODEL	Features	H	MODEL NUMBER					Approx. Packaged Weight	Freight Excluded Pricing Unupholstered	Freight Excluded Pricing Fabric Grade 1 & C.O.M.	Freight Excluded Pricing Fabric Grade 2	Freight Excluded Pricing Fabric Grade 3 & Group 2V Vinyl	Freight Excluded Pricing Pallas Fabric Group P0	Freight Excluded Pricing Pallas Fabric Group P1	Freight Excluded Pricing Pallas Fabric Group P2	Freight Excluded Pricing Pallas Fabric Group P3	Freight Excluded Pricing Pallas Fabric Group P4	
			Basic Model	Poly Color	Frame Color	Glide Option	Upholstery Color											
 Stack Chair with Glides • Ships fully assembled, packaged 1 chair per carton • 15" chair stacks 3 high • 18" chair stacks 4 high	Polypropylene	15"	RKU100H15NB	<input type="checkbox"/> <input type="checkbox"/> <input type="checkbox"/>	<input type="checkbox"/>	<input type="checkbox"/> <input type="checkbox"/> <input type="checkbox"/>		34.00#	\$ 293									
	Polypropylene	18"	RKU100H18NB	<input type="checkbox"/> <input type="checkbox"/> <input type="checkbox"/>	<input type="checkbox"/>	<input type="checkbox"/> <input type="checkbox"/> <input type="checkbox"/>		35.00#	296									
RKU1	 Stack Chair with Glides • Ships assembled, packaged 1 chair per carton • 15" chair stacks 2 high • 18" chair stacks 3 high	Upholstered Seat	15"	RKU200H15NB	<input type="checkbox"/> <input type="checkbox"/> <input type="checkbox"/>	<input type="checkbox"/>	<input type="checkbox"/> <input type="checkbox"/> <input type="checkbox"/>	<input type="checkbox"/> <input type="checkbox"/> <input type="checkbox"/> <input type="checkbox"/>	36.50#	N/A	\$ 418	\$ 429	\$ 448	\$ 461	\$ 523	\$ 542	\$ 568	\$ 601
		Upholstered Seat	18"	RKU200H18NB	<input type="checkbox"/> <input type="checkbox"/> <input type="checkbox"/>	<input type="checkbox"/>	<input type="checkbox"/> <input type="checkbox"/> <input type="checkbox"/>	<input type="checkbox"/> <input type="checkbox"/> <input type="checkbox"/>	37.50#	N/A	421	433	453	466	526	545	571	606

A **B** **C** **D** **E**

HOW TO ORDER

- Indicate the following information on order form:
- Quantity of each item.
 - Model number, including options. See "How To Build a Model Number".
 - Any special service required.

Note: • The indicates that a choice is required.
 • The absence of the indicates that no choice is required.
 • Alpha-numeric characters in place of indicate that no other alternatives are available.

HOW TO BUILD A MODEL NUMBER

- A** Select basic model.
- B** Select poly color. Refer to the **Product Color Options** page in this price list.
- C** Select frame finish. Refer to the **Product Color Options** page in this price list.
- D** Select glide option.

GFT	- Felt glides
GPL	- Nylon plastic glides
GSL	- Steel glides
- E** Select upholstery grade/color. Refer to ki.com/fabrics

UPHOLSTERY INFORMATION

C.O.M. Upholstery
 C.O.M. requirement for 10 chairs or less with upholstered seat or upholstered seat and back is 3/4 yard per chair of 54" wide nondirectional fabric. For orders of 11 or more with upholstered seat and back and for complete information on ordering C.O.M. see "Ordering C.O.M., C.O.V. and C.O.L." section.

SPECIAL SERVICES

Special Carton Marking

With specially marked information N/C

Shipping
 Ships **assembled, FOB Green Bay, WI 54302, freight excluded.** Freight class 125.

Specifications and prices are subject to change without prior notice.



Ruckus® Seating (Freight Excluded Pricing)

Stack Chair with Glides



Ruckus® Seating (Freight Excluded Pricing)

Stack Chair with Glides

MODEL	Features	H	MODEL NUMBER						Approx. Packaged Weight	Freight Excluded Pricing Unupholstered	Freight Excluded Pricing Fabric Grade 1 & C.O.M.	Freight Excluded Pricing Fabric Grade 2	Freight Excluded Pricing Fabric Grade 3 & Group 2V Vinyl	Freight Excluded Pricing Pallas Fabric Group P0	Freight Excluded Pricing Pallas Fabric Group P1	Freight Excluded Pricing Pallas Fabric Group P2	Freight Excluded Pricing Pallas Fabric Group P3	Freight Excluded Pricing Pallas Fabric Group P4	
			Basic Model	Poly Color	Frame Color	Bookbag Rack Color	Glide Option	Upholstery Color											
 Stack Chair with Glides and Bookbag Rack • Ships fully assembled, packaged 1 chair per carton • 15" chair stacks 3 high • 18" chair stacks 4 high	Polypropylene	15"	RKU100H15BR	<input type="checkbox"/>	<input type="checkbox"/>	<input type="checkbox"/>	<input type="checkbox"/>	<input type="checkbox"/>	37.00#	\$ 356									
	Polypropylene	18"	RKU100H18BR	<input type="checkbox"/>	<input type="checkbox"/>	<input type="checkbox"/>	<input type="checkbox"/>	<input type="checkbox"/>	38.00#	362									
RKU1	 Stack Chair with Glides and Bookbag Rack • Ships fully assembled, packaged 1 chair per carton • 15" chair stacks 2 high • 18" chair stacks 3 high	Upholstered Seat	15"	RKU200H15BR	<input type="checkbox"/>	<input type="checkbox"/>	<input type="checkbox"/>	<input type="checkbox"/>	<input type="checkbox"/>	39.50#	N/A	\$ 482	\$ 493	\$ 514	\$ 524	\$ 585	\$ 606	\$ 631	\$ 666
		Upholstered Seat	18"	RKU200H18BR	<input type="checkbox"/>	<input type="checkbox"/>	<input type="checkbox"/>	<input type="checkbox"/>	<input type="checkbox"/>	<input type="checkbox"/>	40.50#	N/A	486	497	517	528	591	609	635
RKU2				A	B	C	D	E	F										

HOW TO ORDER

- Indicate the following information on order form:
- Quantity of each item.
 - Model number, including options. See "How To Build a Model Number".
 - Any special service required.

Note: • The indicates that a choice is required.
 • The absence of the indicates that no choice is required.
 • Alpha-numeric characters in place of indicate that no other alternatives are available.

HOW TO BUILD A MODEL NUMBER

- A** Select basic model.
- B** Select poly color. Refer to the **Product Color Options** page in this price list.
- C** Select frame finish. Refer to the **Product Color Options** page in this price list.
- D** Select bookbag rack color. Refer to the **Product Color Options** page in this price list.
- E** Select glide option.

GFT	- Felt glides
GPL	- Nylon plastic glides
GSL	- Steel glides
- F** Select upholstery grade/color. Refer to ki.com/fabrics

UPHOLSTERY INFORMATION

C.O.M. Upholstery
 C.O.M. requirement for 10 chairs or less with upholstered seat or upholstered seat and back is 3/4 yard per chair of 54" wide nondirectional fabric. For orders of 11 or more with upholstered seat and back and for complete information on ordering C.O.M. see "Ordering C.O.M., C.O.V. and C.O.L." section.

SPECIAL SERVICES

Special Carton Marking

With specially marked information N/C

Shipping
 Ships assembled, FOB Green Bay, WI 54302, freight excluded. Freight class 125.

Specifications and prices are subject to change without prior notice.



Ruckus® Seating (Freight Excluded Pricing)

Stack Chair with Casters



Ruckus® Seating (Freight Excluded Pricing)

Stack Chair with Casters

MODEL	Features	H	MODEL NUMBER					Approx. Packaged Weight	Freight Excluded Pricing Unupholstered	Freight Excluded Pricing Fabric Grade 1 & C.O.M.	Freight Excluded Pricing Fabric Grade 2	Freight Excluded Pricing Fabric Grade 3 & Group 2V Vinyl	Freight Excluded Pricing Pallas Fabric Group P0	Freight Excluded Pricing Pallas Fabric Group P1	Freight Excluded Pricing Pallas Fabric Group P2	Freight Excluded Pricing Pallas Fabric Group P3	Freight Excluded Pricing Pallas Fabric Group P4	
			Basic Model	Poly Color	Frame Color	Caster Type	Upholstery Color											
 <p>Stack Chair with Casters • Ships fully assembled, packaged 1 chair per carton • 15" chair stacks 3 high • 18" chair stacks 4 high</p>	Polypropylene	15"	RKV100H15NB	<input type="checkbox"/> <input type="checkbox"/> <input type="checkbox"/>	<input type="checkbox"/>	<input type="checkbox"/> <input type="checkbox"/> <input type="checkbox"/>												
	Polypropylene	18"	RKV100H18NB	<input type="checkbox"/> <input type="checkbox"/> <input type="checkbox"/>	<input type="checkbox"/>	<input type="checkbox"/> <input type="checkbox"/> <input type="checkbox"/>	34.50#	\$ 308										
							35.50#	313										
RKV1																		
 <p>Stack Chair with Casters • Ships fully assembled, packaged 1 chair per carton • 15" chair stacks 2 high • 18" chair stacks 3 high</p>	Upholstered Seat	15"	RKV200H15NB	<input type="checkbox"/> <input type="checkbox"/> <input type="checkbox"/>	<input type="checkbox"/>	<input type="checkbox"/> <input type="checkbox"/> <input type="checkbox"/>	<input type="checkbox"/> <input type="checkbox"/> <input type="checkbox"/> <input type="checkbox"/>	37.00#	N/A	\$ 433	\$ 444	\$ 466	\$ 475	\$ 539	\$ 555	\$ 581	\$ 618	
	Upholstered Seat	18"	RKV200H18NB	<input type="checkbox"/> <input type="checkbox"/> <input type="checkbox"/>	<input type="checkbox"/>	<input type="checkbox"/> <input type="checkbox"/> <input type="checkbox"/>	<input type="checkbox"/> <input type="checkbox"/> <input type="checkbox"/>	38.00#	N/A	438	447	469	479	542	559	584	621	
RKV2																		

A B C D E

HOW TO ORDER

- Indicate the following information on order form:
- Quantity of each item.
 - Model number, including options. See "How To Build a Model Number".
 - Any special service required.

Note: • The indicates that a choice is required.
 • The absence of the indicates that no choice is required.
 • Alpha-numeric characters in place of indicate that no other alternatives are available.

HOW TO BUILD A MODEL NUMBER

- A** Select basic model.
- B** Select poly color. Refer to the **Product Color Options** page in this price list.
- C** Select frame finish. Refer to the **Product Color Options** page in this price list.
- D** Select caster type.

CHC	- Hard floor casters
CCC	- Carpet casters
- E** Select upholstery grade/color. Refer to ki.com/fabrics

UPHOLSTERY INFORMATION

C.O.M. Upholstery
 C.O.M. requirement for 10 chairs or less with upholstered seat or upholstered seat and back is 3/4 yard per chair of 54" wide nondirectional fabric. For orders of 11 or more with upholstered seat and back and for complete information on ordering C.O.M. see "Ordering C.O.M., C.O.V. and C.O.L." section.

SPECIAL SERVICES

Special Carton Marking

With specially marked information N/C

Shipping

Ships **assembled, FOB Green Bay, WI 54302, freight excluded.** Freight class 125.

Specifications and prices are subject to change without prior notice.



Ruckus® Seating (Freight Excluded Pricing)

Stack Chair with Casters



Ruckus® Seating (Freight Excluded Pricing)

Stack Chair with Casters

MODEL	Features	H	MODEL NUMBER						Approx. Packaged Weight	Freight Excluded Pricing Unupholstered	Freight Excluded Pricing Fabric Grade 1 & C.O.M.	Freight Excluded Pricing Fabric Grade 2	Freight Excluded Pricing Fabric Grade 3 & Group 2V Vinyl	Freight Excluded Pricing Pallas Fabric Group P0	Freight Excluded Pricing Pallas Fabric Group P1	Freight Excluded Pricing Pallas Fabric Group P2	Freight Excluded Pricing Pallas Fabric Group P3	Freight Excluded Pricing Pallas Fabric Group P4	
			Basic Model	Poly Color	Frame Color	Bookbag Rack Color	Caster Type	Upholstery Color											
 Stack Chair with Casters and Bookbag Rack • Ships fully assembled, packaged 1 chair per carton • 15" chair stacks 3 high • 18" chair stacks 4 high	Polypropylene	15"	RKV100H15BR	<input type="checkbox"/> <input type="checkbox"/> <input type="checkbox"/>	<input type="checkbox"/>	<input type="checkbox"/> <input type="checkbox"/> <input type="checkbox"/> <input type="checkbox"/>	<input type="checkbox"/> <input type="checkbox"/>		37.50#	\$ 372									
	Polypropylene	18"	RKV100H18BR	<input type="checkbox"/> <input type="checkbox"/> <input type="checkbox"/>	<input type="checkbox"/>	<input type="checkbox"/> <input type="checkbox"/> <input type="checkbox"/> <input type="checkbox"/>	<input type="checkbox"/> <input type="checkbox"/>		38.50#	375									
RKV1	 Stack Chair with Casters and Bookbag Rack • Ships fully assembled, packaged 1 chair per carton • 15" chair stacks 2 high • 18" chair stacks 3 high	Upholstered Seat	15"	RKV200H15BR	<input type="checkbox"/> <input type="checkbox"/> <input type="checkbox"/>	<input type="checkbox"/>	<input type="checkbox"/> <input type="checkbox"/> <input type="checkbox"/> <input type="checkbox"/>	<input type="checkbox"/> <input type="checkbox"/>	<input type="checkbox"/> <input type="checkbox"/> <input type="checkbox"/> <input type="checkbox"/>	40.00#	N/A	\$ 497	\$ 507	\$ 528	\$ 540	\$ 601	\$ 621	\$ 646	\$ 680
		Upholstered Seat	18"	RKV200H18BR	<input type="checkbox"/> <input type="checkbox"/> <input type="checkbox"/>	<input type="checkbox"/>	<input type="checkbox"/> <input type="checkbox"/> <input type="checkbox"/> <input type="checkbox"/>	<input type="checkbox"/> <input type="checkbox"/>	<input type="checkbox"/> <input type="checkbox"/> <input type="checkbox"/> <input type="checkbox"/>	41.00#	N/A	501	513	532	543	606	625	649	684
RKV2				A	B	C	D	E	F										

HOW TO ORDER

- Indicate the following information on order form:
- Quantity of each item.
 - Model number, including options. See "How To Build a Model Number".
 - Any special service required.

Note: • The indicates that a choice is required.
 • The absence of the indicates that no choice is required.
 • Alpha-numeric characters in place of indicate that no other alternatives are available.

HOW TO BUILD A MODEL NUMBER

- A** Select basic model.
- B** Select poly color. Refer to the **Product Color Options** page in this price list.
- C** Select frame finish. Refer to the **Product Color Options** page in this price list.
- D** Select bookbag rack color. Refer to the **Product Color Options** page in this price list.
- E** Select caster type.
CHC - Hard floor casters
CCC - Carpet casters
- F** Select upholstery grade/color. Refer to ki.com/fabrics

UPHOLSTERY INFORMATION

C.O.M. Upholstery
 C.O.M. requirement for 10 chairs or less with upholstered seat or upholstered seat and back is 3/4 yard per chair of 54" wide nondirectional fabric. For orders of 11 or more with upholstered seat and back and for complete information on ordering C.O.M. see "Ordering C.O.M., C.O.V. and C.O.L." section.

SPECIAL SERVICES

Special Carton Marking

With specially marked information N/C

Shipping

Ships assembled, FOB Green Bay, WI 54302, freight excluded. Freight class 125.

Specifications and prices are subject to change without prior notice.



Ruckus® Seating (Freight Excluded Pricing)

Stool with Glides



Ruckus® Seating (Freight Excluded Pricing)

Stool with Glides

MODEL	Features	H	MODEL NUMBER					Approx. Packaged Weight	Freight Excluded Pricing Unupholstered	Freight Excluded Pricing Fabric Grade 1 & C.O.M.	Freight Excluded Pricing Fabric Grade 2	Freight Excluded Pricing Fabric Grade 3 & Group 2V Vinyl	Freight Excluded Pricing Pallas Fabric Group P0	Freight Excluded Pricing Pallas Fabric Group P1	Freight Excluded Pricing Pallas Fabric Group P2	Freight Excluded Pricing Pallas Fabric Group P3	Freight Excluded Pricing Pallas Fabric Group P4
			Basic Model	Poly Color	Frame Color	Glide Option	Upholstery Color										
 <p>Stool with Glides and No Bookbag Rack • Ships fully assembled, packaged 1 chair per carton • Stacks 3 high</p>	Polypropylene	24"	RK4100H24NB	<input type="checkbox"/>	<input type="checkbox"/>	<input type="checkbox"/>		42.00#	\$ 370								
	Polypropylene	30"	RK4100H30NB	<input type="checkbox"/>	<input type="checkbox"/>	<input type="checkbox"/>		43.00#	383								
 <p>Stool with Glides and No Bookbag Rack • Ships fully assembled, packaged 1 chair per carton • Stacks 3 high</p>	Upholstered Seat	24"	RK4200H24NB	<input type="checkbox"/>	<input type="checkbox"/>	<input type="checkbox"/>	<input type="checkbox"/>	44.50#	N/A	\$ 501	\$ 514	\$ 534	\$ 545	\$ 611	\$ 632	\$ 658	\$ 695
	Upholstered Seat	30"	RK4200H30NB	<input type="checkbox"/>	<input type="checkbox"/>	<input type="checkbox"/>	<input type="checkbox"/>	45.50#	N/A	515	526	547	558	627	646	673	707

RK41

RK42

A B C D E

HOW TO ORDER

- Indicate the following information on order form:
- Quantity of each item.
 - Model number, including options. See "How To Build a Model Number".
 - Any special service required.

Note: • The indicates that a choice is required.
 • The absence of the indicates that no choice is required.
 • Alpha-numeric characters in place of indicate that no other alternatives are available.

HOW TO BUILD A MODEL NUMBER

- A** Select basic model.
- B** Select poly color. Refer to the **Product Color Options** page in this price list.
- C** Select frame finish. Refer to the **Product Color Options** page in this price list.
- D** Select glide option.

GFT	- Felt glides
GPL	- Nylon plastic glides
GSL	- Steel glides
- E** Select upholstery grade/color. Refer to ki.com/fabrics

UPHOLSTERY INFORMATION

C.O.M. Upholstery
 C.O.M. requirement for 10 chairs or less with upholstered seat or upholstered seat and back is 3/4 yard per chair of 54" wide nondirectional fabric. For orders of 11 or more with upholstered seat and back and for complete information on ordering C.O.M. see "Ordering C.O.M., C.O.V. and C.O.L." section.

SPECIAL SERVICES

Special Carton Marking

With specially marked information N/C

Shipping

Ships assembled, FOB Green Bay, WI 54302, freight excluded. Freight class 250.

Specifications and prices are subject to change without prior notice.



Ruckus® Seating (Freight Excluded Pricing)

Stool with Glides



Ruckus® Seating (Freight Excluded Pricing)

Stool with Glides

MODEL	Features	H	MODEL NUMBER						Approx. Packaged Weight	Freight Excluded Pricing Unupholstered	Freight Excluded Pricing Fabric Grade 1 & C.O.M.	Freight Excluded Pricing Fabric Grade 2	Freight Excluded Pricing Fabric Grade 3 & Group 2V Vinyl	Freight Excluded Pricing Pallas Fabric Group P0	Freight Excluded Pricing Pallas Fabric Group P1	Freight Excluded Pricing Pallas Fabric Group P2	Freight Excluded Pricing Pallas Fabric Group P3	Freight Excluded Pricing Pallas Fabric Group P4
			Basic Model	Poly Color	Frame Color	Bookbag Rack Color	Glide Option	Upholstery Color										
 RK41 Stool with Glides and Bookbag Rack • Ships fully assembled, packaged 1 chair per carton • Stacks 3 high	Polypropylene	24"	RK4100H24BR	<input type="checkbox"/> <input type="checkbox"/> <input type="checkbox"/>	<input type="checkbox"/>	<input type="checkbox"/> <input type="checkbox"/> <input type="checkbox"/> <input type="checkbox"/>	<input type="checkbox"/> <input type="checkbox"/>		45.00#	\$ 437								
	Polypropylene	30"	RK4100H30BR	<input type="checkbox"/> <input type="checkbox"/> <input type="checkbox"/>	<input type="checkbox"/>	<input type="checkbox"/> <input type="checkbox"/> <input type="checkbox"/> <input type="checkbox"/>	<input type="checkbox"/> <input type="checkbox"/>		46.00#	448								
 RK42 Stool with Glides and Bookbag Rack • Ships fully assembled, packaged 1 chair per carton • Stacks 3 high	Upholstered Seat	24"	RK4200H24BR	<input type="checkbox"/> <input type="checkbox"/> <input type="checkbox"/>	<input type="checkbox"/>	<input type="checkbox"/> <input type="checkbox"/> <input type="checkbox"/> <input type="checkbox"/>	<input type="checkbox"/> <input type="checkbox"/>	<input type="checkbox"/> <input type="checkbox"/> <input type="checkbox"/> <input type="checkbox"/>	47.50#	N/A	\$ 570	\$ 580	\$ 601	\$ 612	\$ 679	\$ 701	\$ 725	\$ 762
	Upholstered Seat	30"	RK4200H30BR	<input type="checkbox"/> <input type="checkbox"/> <input type="checkbox"/>	<input type="checkbox"/>	<input type="checkbox"/> <input type="checkbox"/> <input type="checkbox"/> <input type="checkbox"/>	<input type="checkbox"/> <input type="checkbox"/>	<input type="checkbox"/> <input type="checkbox"/> <input type="checkbox"/> <input type="checkbox"/>	48.50#	N/A	581	593	616	627	692	712	737	776

A **B** **C** **D** **E** **F**

HOW TO ORDER

- Indicate the following information on order form:
- Quantity of each item.
 - Model number, including options. See "How To Build a Model Number".
 - Any special service required.

Note:

- The indicates that a choice is required.
- The absence of the indicates that no choice is required.
- Alpha-numeric characters in place of indicate that no other alternatives are available.

HOW TO BUILD A MODEL NUMBER

- A** Select basic model.
- B** Select poly color. Refer to the **Product Color Options** page in this price list.
- C** Select frame finish. Refer to the **Product Color Options** page in this price list.
- D** Select bookbag rack color. Refer to the **Product Color Options** page in this price list.
- E** Select glide option.

GFT	- Felt glides
GPL	- Nylon plastic glides
GSL	- Steel glides
- F** Select upholstery grade/color. Refer to ki.com/fabrics

UPHOLSTERY INFORMATION

C.O.M. Upholstery
 C.O.M. requirement for 10 chairs or less with upholstered seat or upholstered seat and back is 3/4 yard per chair of 54" wide nondirectional fabric. For orders of 11 or more with upholstered seat and back and for complete information on ordering C.O.M. see "Ordering C.O.M., C.O.V. and C.O.L." section.

SPECIAL SERVICES

Special Carton Marking

With specially marked information N/C

Shipping

Ships assembled, FOB Green Bay, WI 54302, freight excluded. Freight class 250.

Specifications and prices are subject to change without prior notice.



Ruckus® Seating (Freight Excluded Pricing)

Stool with Casters



Ruckus® Seating (Freight Excluded Pricing)

Stool with Casters

MODEL	Features	H	MODEL NUMBER					Approx. Packaged Weight	Freight Excluded Pricing Unupholstered	Freight Excluded Pricing Fabric Grade 1 & C.O.M.	Freight Excluded Pricing Fabric Grade 2	Freight Excluded Pricing Fabric Grade 3 & Group 2V Vinyl	Freight Excluded Pricing Pallas Fabric Group P0	Freight Excluded Pricing Pallas Fabric Group P1	Freight Excluded Pricing Pallas Fabric Group P2	Freight Excluded Pricing Pallas Fabric Group P3	Freight Excluded Pricing Pallas Fabric Group P4
			Basic Model	Poly Color	Frame Color	Glide Option	Upholstery Color										
 Stool with Casters and No Bookbag Rack • Ships fully assembled, packaged 1 chair per carton • Stacks 3 high	Polypropylene	24"	RKN100H24NB	<input type="checkbox"/> <input type="checkbox"/> <input type="checkbox"/>	<input type="checkbox"/>	<input type="checkbox"/> <input type="checkbox"/> <input type="checkbox"/>		42.00#	\$ 396								
	Polypropylene	30"	RKN100H30NB	<input type="checkbox"/> <input type="checkbox"/> <input type="checkbox"/>	<input type="checkbox"/>	<input type="checkbox"/> <input type="checkbox"/> <input type="checkbox"/>		43.00#	410								
 Stool with Casters and No Bookbag Rack • Ships fully assembled, packaged 1 chair per carton • Stacks 3 high	Upholstered Seat	24"	RKN200H24NB	<input type="checkbox"/> <input type="checkbox"/> <input type="checkbox"/>	<input type="checkbox"/>	<input type="checkbox"/> <input type="checkbox"/> <input type="checkbox"/>	<input type="checkbox"/> <input type="checkbox"/> <input type="checkbox"/> <input type="checkbox"/>	44.50#	N/A	\$ 527	\$ 540	\$ 559	\$ 572	\$ 638	\$ 658	\$ 684	\$ 722
	Upholstered Seat	30"	RKN200H30NB	<input type="checkbox"/> <input type="checkbox"/> <input type="checkbox"/>	<input type="checkbox"/>	<input type="checkbox"/> <input type="checkbox"/> <input type="checkbox"/>	<input type="checkbox"/> <input type="checkbox"/> <input type="checkbox"/> <input type="checkbox"/>	45.50#	N/A	541	552	573	584	653	673	697	734

A **B** **C** **D** **E**

HOW TO ORDER

- Indicate the following information on order form:
- Quantity of each item.
 - Model number, including options. See "How To Build a Model Number".
 - Any special service required.

Note: • The indicates that a choice is required.
 • The absence of the indicates that no choice is required.
 • Alpha-numeric characters in place of indicate that no other alternatives are available.

HOW TO BUILD A MODEL NUMBER

- A** Select basic model.
- B** Select poly color.
Refer to the **Product Color Options** page in this price list.
- C** Select frame finish.
Refer to the **Product Color Options** page in this price list.
- D** Select caster option.

CHC	- Hard floor casters
CCC	- Carpet casters
- E** Select upholstery grade/color.
Refer to ki.com/fabrics

UPHOLSTERY INFORMATION

C.O.M. Upholstery
 C.O.M. requirement for 10 chairs or less with upholstered seat or upholstered seat and back is 3/4 yard per chair of 54" wide nondirectional fabric. For orders of 11 or more with upholstered seat and back and for complete information on ordering C.O.M. see "Ordering C.O.M., C.O.V. and C.O.L." section.

SPECIAL SERVICES

Special Carton Marking

With specially marked information N/C

Shipping

Ships assembled, FOB Green Bay, WI 54302, freight excluded. Freight class 250.

Specifications and prices are subject to change without prior notice.



Ruckus® Seating (Freight Excluded Pricing)

Stool with Casters

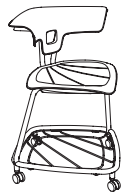

Ruckus® Seating (Freight Excluded Pricing)

Stool with Casters

MODEL	Features	H	MODEL NUMBER						Approx. Packaged Weight	Freight Excluded Pricing Unupholstered	Freight Excluded Pricing Fabric Grade 1 & C.O.M.	Freight Excluded Pricing Fabric Grade 2	Freight Excluded Pricing Fabric Grade 3 & Group 2V Vinyl	Freight Excluded Pricing Pallas Fabric Group P0	Freight Excluded Pricing Pallas Fabric Group P1	Freight Excluded Pricing Pallas Fabric Group P2	Freight Excluded Pricing Pallas Fabric Group P3	Freight Excluded Pricing Pallas Fabric Group P4
			Basic Model	Poly Color	Frame Color	Bookbag Rack Color	Glide Option	Upholstery Color										
 <p>Stool with Casters and Bookbag Rack • Ships fully assembled, packaged 1 chair per carton • Stacks 3 high</p>	Polypropylene	24"	RKN100H24BR	<input type="checkbox"/>	<input type="checkbox"/>	<input type="checkbox"/>	<input type="checkbox"/>	<input type="checkbox"/>	45.00#	\$ 462								
	Polypropylene	30"	RKN100H30BR	<input type="checkbox"/>	<input type="checkbox"/>	<input type="checkbox"/>	<input type="checkbox"/>	<input type="checkbox"/>	46.00#	475								
 <p>Stool with Casters and Bookbag Rack • Ships fully assembled, packaged 1 chair per carton • Stacks 3 high</p>	Upholstered Seat	24"	RKN200H24BR	<input type="checkbox"/>	<input type="checkbox"/>	<input type="checkbox"/>	<input type="checkbox"/>	<input type="checkbox"/>	47.50#	N/A	\$ 596	\$ 606	\$ 628	\$ 639	\$ 705	\$ 726	\$ 751	\$ 789
	Upholstered Seat	30"	RKN200H30BR	<input type="checkbox"/>	<input type="checkbox"/>	<input type="checkbox"/>	<input type="checkbox"/>	<input type="checkbox"/>	48.50#	N/A	607	620	641	653	718	739	763	802

A **B** **C** **D** **E** **F**

HOW TO ORDER

- Indicate the following information on order form:
- Quantity of each item.
 - Model number, including options. See "How To Build a Model Number".
 - Any special service required.

Note:

- The indicates that a choice is required.
- The absence of the indicates that no choice is required.
- Alpha-numeric characters in place of indicate that no other alternatives are available.

HOW TO BUILD A MODEL NUMBER

- A** Select basic model.
- B** Select poly color. Refer to the **Product Color Options** page in this price list.
- C** Select frame finish. Refer to the **Product Color Options** page in this price list.
- D** Select bookbag rack color. Refer to the **Product Color Options** page in this price list.
- E** Select caster option.
CHC - Hard floor casters
CCC - Carpet casters
- F** Select upholstery grade/color. Refer to ki.com/fabrics

UPHOLSTERY INFORMATION

C.O.M. Upholstery
 C.O.M. requirement for 10 chairs or less with upholstered seat or upholstered seat and back is 3/4 yard per chair of 54" wide nondirectional fabric. For orders of 11 or more with upholstered seat and back and for complete information on ordering C.O.M. see "Ordering C.O.M., C.O.V. and C.O.L." section.

SPECIAL SERVICES

Special Carton Marking

With specially marked information N/C

Shipping

Ships assembled, FOB Green Bay, WI 54302, freight excluded. Freight class 250.

Specifications and prices are subject to change without prior notice.



Ruckus® Seating (Freight Excluded Pricing)

Task Chair



Ruckus® Seating (Freight Excluded Pricing)

Task Chair

MODEL	Features	MODEL NUMBER					Approx. Packaged Weight	Freight Excluded Pricing Unupholstered	Freight Excluded Pricing Fabric Grade 1 & C.O.M.	Freight Excluded Pricing Fabric Grade 2	Freight Excluded Pricing Fabric Grade 3 & Group 2V Vinyl	Freight Excluded Pricing Pallas Fabric Group P0	Freight Excluded Pricing Pallas Fabric Group P1	Freight Excluded Pricing Pallas Fabric Group P2	Freight Excluded Pricing Pallas Fabric Group P3	Freight Excluded Pricing Pallas Fabric Group P4
		Basic Model	Poly Color	Frame Color	Caster Type	Upholstery Color										
 Task Chair • Ships KD, packaged 1 chair per carton • Utilizes 28" 5-blade base	Polypropylene	RK5100	<input type="checkbox"/>	<input type="checkbox"/>	<input type="checkbox"/>	<input type="checkbox"/>	36.00#	\$ 373								
RK51  Task Chair • Ships KD, packaged 1 chair per carton • Utilizes 28" 5-blade base	Upholstered Seat	RK5200	<input type="checkbox"/>	<input type="checkbox"/>	<input type="checkbox"/>	<input type="checkbox"/>	38.50#	N/A	\$ 498	\$ 508	\$ 530	\$ 541	\$ 603	\$ 622	\$ 647	\$ 682
			A	B	C	D	E									

HOW TO ORDER

- Indicate the following information on order form:
- Quantity of each item.
 - Model number, including options. See "How To Build a Model Number".
 - Any special service required.

Note: • The indicates that a choice is required.
 • The absence of the indicates that no choice is required.
 • Alpha-numeric characters in place of indicate that no other alternatives are available.

HOW TO BUILD A MODEL NUMBER

- A** Select basic model.
- B** Select poly color.
Refer to the **Product Color Options** page in this price list.
- C** Select frame color.
Refer to the **Product Color Options** page in this price list.
- D** Select caster or glide type.

CHC	- Hard floor casters
CCC	- Carpet casters
GBG	- Bell glide
- E** Select upholstery grade/color.
Refer to ki.com/fabrics

UPHOLSTERY INFORMATION

C.O.M. Upholstery
 C.O.M. requirement for 10 chairs or less with upholstered seat or upholstered seat and back is 3/4 yard per chair of 54" wide nondirectional fabric. For orders of 11 or more with upholstered seat and back and for complete information on ordering C.O.M. see "Ordering C.O.M., C.O.V. and C.O.L." section.

SPECIAL SERVICES

Special Carton Marking

With specially marked information N/C

Shipping
 Ships **partially assembled, FOB Green Bay, WI 54302, freight excluded.** Freight class 250.

Specifications and prices are subject to change without prior notice.

Ruckus® Mobile Lectern (Freight Excluded Pricing)

Mobile Lectern



Ruckus® Mobile Lectern (Freight Excluded Pricing)

Mobile Lectern

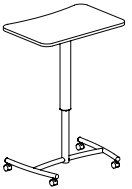
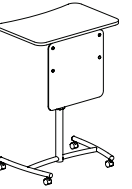
MODEL	MODEL NUMBER								Approx. Packaged Weight	Freight Excluded Pricing	Laminate Grade 2 add to list price
	Basic Model	Storage Accessories	Base	Top Color	Edge Color	Base Color	Book Basket Color	Acrylic Modesty Panel Color			
 <p>Mobile Lectern</p> <ul style="list-style-type: none"> 20" x 30" Laminate worksurface with curved front only Ships fully assembled, packaged 1 lectern per carton 28-3/4" to 42-3/4" height range When chrome is selected the lower frame will be chrome and the upper column assembly will be starlight silver Lectern is always on casters 	RUW20E	<input type="checkbox"/> <input type="checkbox"/> <input type="checkbox"/> <input type="checkbox"/>	<input type="checkbox"/> <input type="checkbox"/>	<input type="checkbox"/> <input type="checkbox"/>	<input type="checkbox"/> <input type="checkbox"/>	<input type="checkbox"/> <input type="checkbox"/>	<input type="checkbox"/> <input type="checkbox"/> <input type="checkbox"/> <input type="checkbox"/>		59.00#	\$ 1082	\$ 19
 <p>Mobile Lectern with Acrylic Modesty Panel</p> <ul style="list-style-type: none"> 20" x 30" Laminate worksurface with curved front only Ships fully assembled, packaged 1 lectern per carton 28-3/4" to 42-3/4" height range When chrome is selected the lower frame will be chrome and the upper column assembly will be starlight silver Lectern is always on casters Includes acrylic modesty panel 	RUX20E	<input type="checkbox"/> <input type="checkbox"/> <input type="checkbox"/> <input type="checkbox"/>	<input type="checkbox"/> <input type="checkbox"/>	<input type="checkbox"/> <input type="checkbox"/>	<input type="checkbox"/> <input type="checkbox"/>	<input type="checkbox"/> <input type="checkbox"/>	<input type="checkbox"/> <input type="checkbox"/> <input type="checkbox"/> <input type="checkbox"/>	<input type="checkbox"/> <input type="checkbox"/>	64.00#	\$ 1358	\$ 19

A

B

C

D

E

F

G

H

HOW TO ORDER

Indicate the following information on order form:

- Quantity of each item.
- Model number, including options. See "How To Build a Model Number".
- Any special service required.

Note: • The indicates that a choice is required.

- The absence of the indicates that no choice is required.

- Alpha-numeric characters in place of indicate that no other alternatives are available.

HOW TO BUILD A MODEL NUMBER

- A** Select basic model.

- B** Select storage/accessories.

NB - No book storage

BH - Bag hooks; add \$11

BR - Book basket; add \$63

CL - Swiveling cup holder - left side;

add \$56

CR - Swiveling cup holder - right side;

add \$56

BHCL - Book bag hook-right side & cup

holder-left side; add \$66

BHCR - Book bag hook-left side & cup

holder-right side; add \$66

BRCL - Book basket & cup holder - left

side; add \$120

BRCR - Book basket & cup holder - right

side; add \$120

- C** Select base option.

CHC - Hard floor casters

CCC - Carpet casters

- D** Select top laminate surface.

Refer to the **Product Color Options** page in this price list.

- E** Select edge color.

Refer to the **Product Color Options** page in this price list.

- F** Select base color.

Refer to the **Product Color Options** page in this price list.

- G** Select book basket color.

Refer to the **Product Color Options** page in this price list.

When Book basket/rack & cup holder (BRCL or BRRCR) is selected the cup holder is always starlight silver metallic.

- H** Select acrylic modesty panel color.

Refer to the **Product Color Options** page in this price list.

FINISH INFORMATION

Additional Laminate Offering

KI offers laminates beyond those offered in the standard offering. Laminates that are currently available in the program can be viewed in KI product specification tools. Requests to add laminates to the program can be submitted via the product modification request process. Please note, requests to add laminates to the program must include the laminate manufacturer's name, color/pattern number, and finish code. Edge options are limited to standard edge colors. If a matching edge is required, this will need to be requested through the product modification request process and may be subject to additional costs. Due to varying manufacturing processes and quality issues with some laminates, some requests may be denied. Extended lead times and minimum order quantities may apply on orders containing special laminates. Contact the product modification team for questions or additional information regarding special laminates and pricing.

SPECIAL SERVICES

Special Carton Marking

With specially marked information N/C

Shipping

Ships assembled, FOB Bondue1, WI 54107, freight excluded. Freight class 125.

Specifications and prices are subject to change without prior notice.

Ruckus® Mobile Lectern (Freight Excluded Pricing)

Mobile Lectern



Ruckus® Mobile Lectern (Freight Excluded Pricing)

Mobile Lectern

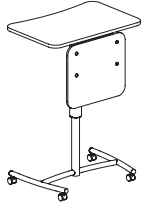
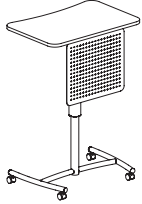
MODEL	MODEL NUMBER										Approx. Packaged Weight	Freight Excluded Pricing	Laminate Grade 2 add to list price	
	Basic Model	Storage Accessories	Base	Top Color	Edge Color	Base Color	Book Basket Color	Felt Modesty Panel Color	Steel Modesty Panel Color					
 <p>Mobile Lectern with Felt Modesty Panel</p> <ul style="list-style-type: none"> • 20" x 30" Laminate worksurface with curved front only • Ships fully assembled, packaged 1 lectern per carton • 28-3/4" to 42-3/4" height range • When chrome is selected the lower frame will be chrome and the upper column assembly will be starlight silver • Lectern is always on casters • Includes felt modesty panel 	RUX22E	<input type="checkbox"/> <input type="checkbox"/> <input type="checkbox"/> <input type="checkbox"/>	<input type="checkbox"/> <input type="checkbox"/>	<input type="checkbox"/> <input type="checkbox"/>	<input type="checkbox"/> <input type="checkbox"/>	<input type="checkbox"/> <input type="checkbox"/>	<input type="checkbox"/> <input type="checkbox"/>	<input type="checkbox"/> <input type="checkbox"/>	<input type="checkbox"/> <input type="checkbox"/>		63.00#	\$ 1338	\$ 19	
 <p>Mobile Lectern with Steel Modesty Panel</p> <ul style="list-style-type: none"> • 20" x 30" Laminate worksurface with curved front only • Ships fully assembled, packaged 1 lectern per carton • 28-3/4" to 42-3/4" height range • When chrome is selected the lower frame will be chrome and the upper column assembly will be starlight silver • Lectern is always on casters • Includes steel modesty panel 	RUX21E	<input type="checkbox"/> <input type="checkbox"/> <input type="checkbox"/> <input type="checkbox"/>	<input type="checkbox"/> <input type="checkbox"/>	<input type="checkbox"/> <input type="checkbox"/>	<input type="checkbox"/> <input type="checkbox"/>	<input type="checkbox"/> <input type="checkbox"/>	<input type="checkbox"/> <input type="checkbox"/>		<input type="checkbox"/> <input type="checkbox"/>		68.00#	\$ 1348	\$ 19	
	A	B	C	D	E	F	G	H	I					

HOW TO ORDER

- Indicate the following information on order form:
1. Quantity of each item.
 2. Model number, including options. See "How To Build a Model Number".
 3. Any special service required.

Note:

- The indicates that a choice is required.
- The absence of the indicates that no choice is required.
- Alpha-numeric characters in place of indicate that no other alternatives are available.

HOW TO BUILD A MODEL NUMBER

- A** Select basic model.
- B** Select storage/accessories.
- NB** - No book storage
 - BH** - Bag hooks; add \$11
 - BR** - Book basket; add \$63
 - CL** - Swiveling cup holder - left side; add \$56
 - CR** - Swiveling cup holder - right side; add \$56
 - BHCL** - Book bag hook-right side & cup holder-left side; add \$66
 - BHCR** - Book bag hook-left side & cup holder-right side; add \$66
 - BRCL** - Book basket & cup holder - left side; add \$120
 - BRCR** - Book basket & cup holder - right side; add \$120
- C** Select base option.
- CHC** - Hard floor casters
 - CCC** - Carpet casters

- D** Select top laminate surface. Refer to the **Product Color Options** page in this price list.
- E** Select edge color. Refer to the **Product Color Options** page in this price list.
- F** Select base color. Refer to the **Product Color Options** page in this price list.
- G** Select book basket color. Refer to the **Product Color Options** page in this price list. When Book basket/rack & cup holder (BRCL or BRRCR) is selected the cup holder is always starlight silver metallic.
- H** Select felt modesty panel color. Refer to the **Product Color Options** page in this price list.
- I** Select steel modesty panel color. Refer to the **Product Color Options** page in this price list.

FINISH INFORMATION

Additional Laminate Offering

KI offers laminates beyond those offered in the standard offering. Laminates that are currently available in the program can be viewed in KI product specification tools. Requests to add laminates to the program can be submitted via the product modification request process. Please note, requests to add laminates to the program must include the laminate manufacturer's name, color/pattern number, and finish code. Edge options are limited to standard edge colors. If a matching edge is required, this will need to be requested through the product modification request process and may be subject to additional costs. Due to varying manufacturing processes and quality issues with some laminates, some requests may be denied. Extended lead times and minimum order quantities may apply on orders containing special laminates. Contact the product modification team for questions or additional information regarding special laminates and pricing.

SPECIAL SERVICES

Special Carton Marking

With specially marked information N/C

Shipping
Ships **assembled, FOB Bonduei, WI 54107, freight excluded.** Freight class 125.

Specifications and prices are subject to change without prior notice.



Ruckus® Cantilever Desk (Freight Excluded Pricing)

Desk

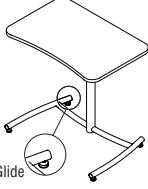
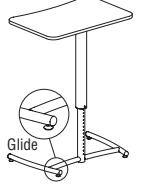

Ruckus® Cantilever Desk (Freight Excluded Pricing)

Desk

MODEL	Features	MODEL NUMBER							Approx. Packaged Weight	Freight Excluded Pricing	Laminate Grade 2 add to list price
		Basic Model	Storage Accessories	Base	Top Color	Edge Color	Base Color	Book Basket Color			
 RU420	Fixed Height - Glide Base 29" High • Laminate curved front only • 20" x 30" worksurface • Ships fully assembled, packaged 1 desk per carton	RU4201	<input type="checkbox"/>	<input type="checkbox"/>	<input type="checkbox"/>	<input type="checkbox"/>	<input type="checkbox"/>	<input type="checkbox"/>	39.0#	\$ 504	\$ 19
 RUD20	Set Screw Adjustable - Glide Base Set Screw Height Adj. • Facilities staff adjusted (tool required) • Laminate curved front only • 20" x 30" worksurface • Ships fully assembled, packaged 1 desk per carton • 27-1/4" - 41-1/2" height range (1" increments) • When chrome is selected the lower frame will be chrome and the upper column assembly will be starlight silver	RUD20A	<input type="checkbox"/>	<input type="checkbox"/>	<input type="checkbox"/>	<input type="checkbox"/>	<input type="checkbox"/>	<input type="checkbox"/>	42.0#	\$ 634	\$ 19
 RUY20	Pneumatic Adjustable - Glide Base Pneumatic Height Adj. • User adjusted • Laminate curved front only • 20" x 30" worksurface • Ships fully assembled, packaged 1 desk per carton • 27-1/4" - 41-1/2" height range • When chrome is selected the lower frame will be chrome and the upper column assembly will be starlight silver	RUY20E	<input type="checkbox"/>	<input type="checkbox"/>	<input type="checkbox"/>	<input type="checkbox"/>	<input type="checkbox"/>	<input type="checkbox"/>	42.0#	\$ 797	\$ 19
			A	B	C	D	E	F			G

HOW TO ORDER

- Indicate the following information on order form:
- Quantity of each item.
 - Model number, including options. See "How To Build a Model Number".
 - Any special service required.

- Note:
- The indicates that a choice is required.
 - The absence of the indicates that no choice is required.
 - Alpha-numeric characters in place of indicate that no other alternatives are available.

HOW TO BUILD A MODEL NUMBER

- A** Select basic model.

- B** Select storage/accessories.

BR - Book basket; add \$63

NB - No book storage

BH - Book bag hook; add \$11

CL - Swiveling cup holder - left side; add \$56

CR - Swiveling cup holder - right side; add \$56

BHCL - Book bag hook-right side & cup holder-left side; add \$66

BHCR - Book bag hook-left side & cup holder-right side; add \$66

BRCL - Book basket & cup holder - left side; add \$120

BRCR - Book basket & cup holder - right side; add \$120

- C** Select base option.

GFT - Felt glides

GPL - Nylon plastic glides

GSL - Steel glides

- D** Select top laminate surface.

Refer to the **Product Color Options** page in this price list.

- E** Select edge color.

Refer to the **Product Color Options** page in this price list.

- F** Select base color.

Refer to the **Product Color Options** page in this price list.

- G** Select book basket color.

Refer to the **Product Color Options** page in this price list.
When Book basket/rack & cup holder (BRCL or BRCR) is selected the cup holder is always starlight silver metallic.

FINISH INFORMATION

Additional Laminate Offering

KI offers laminates beyond those offered in the standard offering. Laminates that are currently available in the program can be viewed in KI product specification tools. Requests to add laminates to the program can be submitted via the product modification request process. Please note, requests to add laminates to the program must include the laminate manufacturer's name, color/pattern number, and finish code. Edge options are limited to standard edge colors. If a matching edge is required, this will need to be requested through the product modification request process and may be subject to additional costs. Due to varying manufacturing processes and quality issues with some laminates, some requests may be denied. Extended lead times and minimum order quantities may apply on orders containing special laminates. Contact the product modification team for questions or additional information regarding special laminates and pricing.

SPECIAL SERVICES

Special Carton Marking

With specially marked information N/C

Shipping

Ships assembled, FOB Bondue1, WI 54107, freight excluded. Freight class 125.

Specifications and prices are subject to change without prior notice.



Ruckus® Cantilever Desk (Freight Excluded Pricing)

Desk

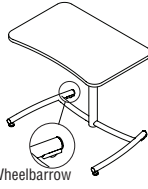

Ruckus® Cantilever Desk (Freight Excluded Pricing)

Desk

MODEL	Features	MODEL NUMBER							Approx. Packaged Weight	Freight Excluded Pricing	Laminate Grade 2 add to list price	
		Basic Model	Storage Accessories	Base	Top Color	Edge Color	Base Color	Book Basket Color				
 RU520	Fixed Height - Rolling Base • Laminate curved front only • 20" x 30" worksurface • Ships fully assembled, packaged 1 desk per carton	29" High	RU5201	<input type="checkbox"/>	<input type="checkbox"/>	<input type="checkbox"/>	<input type="checkbox"/>	<input type="checkbox"/>	<input type="checkbox"/>	39.0#	\$ 543	\$ 19
 RUE20	Set Screw Adjustable - Rolling Base • Facilities staff adjusted (tool required) • Laminate curved front only • 20" x 30" worksurface • Ships fully assembled, packaged 1 desk per carton • 27-1/4" - 41-1/2" height range (1" increments) • When chrome is selected the lower frame will be chrome and the upper column assembly will be starlight silver	Set Screw Height Adj	RUE20A	<input type="checkbox"/>	<input type="checkbox"/>	<input type="checkbox"/>	<input type="checkbox"/>	<input type="checkbox"/>	<input type="checkbox"/>	42.0#	\$ 663	\$ 19
 RUZ20	Pneumatic Adjustable - Rolling Base • User adjusted • Laminate curved front only • 20" x 30" worksurface • Ships fully assembled, packaged 1 desk per carton • 27-1/4" - 41-1/2" height range • When chrome is selected the lower frame will be chrome and the upper column assembly will be starlight silver	Pneumatic Height Adj.	RUZ20E	<input type="checkbox"/>	<input type="checkbox"/>	<input type="checkbox"/>	<input type="checkbox"/>	<input type="checkbox"/>	<input type="checkbox"/>	42.0#	\$ 819	\$ 19

A **B** **C** **D** **E** **F** **G**

HOW TO ORDER

- Indicate the following information on order form:
- Quantity of each item.
 - Model number, including options. See "How To Build a Model Number".
 - Any special service required.

- Note:
- The indicates that a choice is required.
 - The absence of the indicates that no choice is required.
 - Alpha-numeric characters in place of indicate that no other alternatives are available.

HOW TO BUILD A MODEL NUMBER

A Select basic model.**B** Select storage/accessories.

- NB** - No book storage
BH - Book bag hook; add \$11
BR - Book basket; add \$63
CL - Swiveling cup holder - left side; add \$56
CR - Swiveling cup holder - right side; add \$56
BHCL - Book bag hook-right side & cup holder-left side; add \$66
BHCR - Book bag hook-left side & cup holder-right side; add \$66
BRCL - Book basket & cup holder - left side; add \$120
BRCR - Book basket & cup holder - right side; add \$120

C Select base option.

- RFT** - Wheelbarrow (rolling front, felt solo glides back)
RPL - Wheelbarrow (roller front, plastic

glides back)

RSL - Wheelbarrow (rolling front, steel glides back)

D Select top laminate surface.

Refer to the **Product Color Options** page in this price list.

E Select edge color.

Refer to the **Product Color Options** page in this price list.

F Select base color.

Refer to the **Product Color Options** page in this price list.

G Select book basket color.

Refer to the **Product Color Options** page in this price list.
 When Book basket/rack & cup holder (BRCL or BRRCR) is selected the cup holder is always starlight silver metallic.

FINISH INFORMATION

Additional Laminate Offering

KI offers laminates beyond those offered in the standard offering. Laminates that are currently available in the program can be viewed in KI product specification tools. Requests to add laminates to the program can be submitted via the product modification request process. Please note, requests to add laminates to the program must include the laminate manufacturer's name, color/pattern number, and finish code. Edge options are limited to standard edge colors. If a matching edge is required, this will need to be requested through the product modification request process and may be subject to additional costs. Due to varying manufacturing processes and quality issues with some laminates, some requests may be denied. Extended lead times and minimum order quantities may apply on orders containing special laminates. Contact the product modification team for questions or additional information regarding special laminates and pricing.

SPECIAL SERVICES

Special Carton Marking

With specially marked information N/C

Shipping

Ships assembled, FOB Bondue, WI 54107, freight excluded. Freight class 125.

Specifications and prices are subject to change without prior notice.

Ruckus® Cantilever Desk (Freight Excluded Pricing)

ADA Desk



Ruckus® Cantilever Desk (Freight Excluded Pricing)

ADA Desk

MODEL	Features	MODEL NUMBER							Approx. Packaged Weight	Freight Excluded Pricing	Laminate Grade 2 add to list price
		Basic Model	Storage Accessories	Base	Top Color	Edge Color	Base Color	Book Basket Color			
ADA Set Screw Adjustable Desk - Rolling Base	Set Screw Adjustable - Rolling Base	RUE50A	<input type="checkbox"/> <input type="checkbox"/> <input type="checkbox"/> <input type="checkbox"/>	<input type="checkbox"/> <input type="checkbox"/>	<input type="checkbox"/> <input type="checkbox"/>	<input type="checkbox"/> <input type="checkbox"/>	<input type="checkbox"/> <input type="checkbox"/>	<input type="checkbox"/> <input type="checkbox"/>	64.0#	\$ 766	\$ 19
	<ul style="list-style-type: none"> Facilities staff adjusted (tool required) Laminate curved front only 25" x 36" laminate worksurface Ships fully assembled, packaged 1 desk per carton 27-1/4" - 31-1/4" height range (1" increments) When chrome is selected the lower frame will be chrome and the upper column assembly will be starlight silver 										
		A	B	C	D	E	F	G			

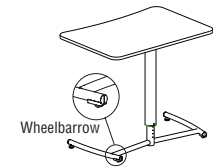

RUE50

HOW TO ORDER

- Indicate the following information on order form:
- Quantity of each item.
 - Model number, including options. See "How To Build a Model Number".
 - Any special service required.

Note:

- The indicates that a choice is required.
- The absence of the indicates that no choice is required.
- Alpha-numeric characters in place of indicate that no other alternatives are available.

HOW TO BUILD A MODEL NUMBER

- A** Select basic model.
- B** Select storage/accessories.
- NB** - No book storage
 - BH** - Book bag hook; add \$11
 - BR** - Book basket; add \$63
 - CL** - Swiveling cup holder - left side; add \$56
 - CR** - Swiveling cup holder - right side; add \$56
 - BHCL** - Book bag hook-right side & cup holder-left side; add \$66
 - BHCR** - Book bag hook-left side & cup holder-right side; add \$66
 - BRCL** - Book basket & cup holder - left side; add \$120
 - BRCR** - Book basket & cup holder - right side; add \$120
- C** Select base option.
- RPL** - Wheelbarrow (roller front, plastic glides back)
 - RSL** - Wheelbarrow (rolling front, steel

- glides back)
 - RFT** - Wheelbarrow (rolling front, felt solo glides back)
- D** Select top laminate surface. Refer to the **Product Color Options** page in this price list.
- E** Select edge color. Refer to the **Product Color Options** page in this price list.
- F** Select base color. Refer to the **Product Color Options** page in this price list.
- G** Select book basket color. Refer to the **Product Color Options** page in this price list. When Book basket/rack & cup holder (BRCL or BRRCR) is selected the cup holder is always starlight silver metallic.

FINISH INFORMATION

Additional Laminate Offering

KI offers laminates beyond those offered in the standard offering. Laminates that are currently available in the program can be viewed in KI product specification tools. Requests to add laminates to the program can be submitted via the product modification request process. Please note, requests to add laminates to the program must include the laminate manufacturer's name, color/pattern number, and finish code. Edge options are limited to standard edge colors. If a matching edge is required, this will need to be requested through the product modification request process and may be subject to additional costs. Due to varying manufacturing processes and quality issues with some laminates, some requests may be denied. Extended lead times and minimum order quantities may apply on orders containing special laminates. Contact the product modification team for questions or additional information regarding special laminates and pricing.

SPECIAL SERVICES

Special Carton Marking

With specially marked information N/C

Shipping

Ships assembled, FOB Bonduei, WI 54107, freight excluded. Freight class 150.

Specifications and prices are subject to change without prior notice.

Ruckus® Stacking Desk (Freight Excluded Pricing)

Rounded Corner



Ruckus® Stacking Desk (Freight Excluded Pricing)

Rounded Corner

MODEL	A x B	MODEL NUMBER					Approx. Packaged Weight	Freight Excluded Pricing	Chrome Upcharge add to list price
		Basic Model/Edge Style	Edge Color	Surface Finish	Base Finish	Base Option			
<p>Fixed Height Rectangular Rounded Corners, 29\"</p> <ul style="list-style-type: none"> Stack up to 4 high Unitized steel frame Ship fully assembled Casters and glides are interchangeable 20x36 and 24x36 desk are ADA compliant 	20 x 30"	RKEAA2030-73P	<input type="checkbox"/>	<input type="checkbox"/>	40.5#	\$ 481	\$ 32		
	20 x 36"	RKEAA2036-73P	<input type="checkbox"/>	<input type="checkbox"/>	43.0#	518	34		
	24 x 30"	RKEAA2430-73P	<input type="checkbox"/>	<input type="checkbox"/>	43.0#	492	34		
	24 x 36"	RKEAA2436-73P	<input type="checkbox"/>	<input type="checkbox"/>	45.5#	525	36		
<p>Adjustable Height Rectangular Rounded Corners, 21-32\"</p> <ul style="list-style-type: none"> Stack up to 4 high Unitized steel frame Ship fully assembled Casters and glides are interchangeable Legs adjust in 1" increments Legs are factory pre-set at 29"H 20x36 and 24x36 desk are ADA compliant 	20 x 30"	RKEEA2030-73P	<input type="checkbox"/>	<input type="checkbox"/>	42.0#	\$ 544	\$ 42		
	20 x 36"	RKEEA2036-73P	<input type="checkbox"/>	<input type="checkbox"/>	44.5#	592	44		
	24 x 30"	RKEEA2430-73P	<input type="checkbox"/>	<input type="checkbox"/>	44.5#	556	44		
	24 x 36"	RKEEA2436-73P	<input type="checkbox"/>	<input type="checkbox"/>	47.0#	596	46		

A **B** **C** **D** **E**

HOW TO ORDER

- Indicate the following information on order form:
- Quantity of each item.
 - Model number, including options. See "How To Build a Model Number".
 - Any special service required.

Note:

- The indicates that a choice is required.
- The absence of the indicates that no choice is required.
- Alpha-numeric characters in place of indicate that no other alternatives are available.

HOW TO BUILD A MODEL NUMBER

- A** Select basic model/edge style.
74P - 1-1/4" laminate top w/74P edge band
- B** Select edge color.
Refer to the **Product Color Options** page in this price list.
- C** Select surface finish.
Refer to the **Product Color Options** page in this price list.
- D** Select base finish.
Refer to the **Product Color Options** page in this price list.
- E** Select base option.
BCF - Casters/felt glides
BCN - Casters/nylon glides
GFT - Felt glides
GNY - Nylon glides
CCC - Casters

SPECIAL SERVICES

Special Carton Marking

With specially marked information N/C

Shipping

Ships **assembled**, **FOB Bonduei, WI 54107**, **freight excluded**. Freight class 125.

Specifications and prices are subject to change without prior notice.

Ruckus® Stacking Desk (Freight Excluded Pricing)

Square Corner



Ruckus® Stacking Desk (Freight Excluded Pricing)

Square Corner

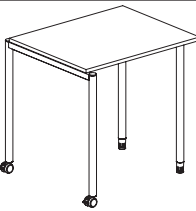
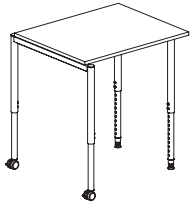
MODEL	A x B	MODEL NUMBER					Approx. Packaged Weight	Freight Excluded Pricing	Chrome Upcharge add to list price
		Basic Model/Edge Style	Edge Color	Surface Finish	Base Finish	Base Option			
 <p>Fixed Height Rectangular Square Corners, 29”H</p> <ul style="list-style-type: none"> Stack up to 4 high Unitized steel frame Ship fully assembled Casters and glides are interchangeable 20x36 and 24x36 desk are ADA compliant 	20 x 30”	RZEEA2030-73P	<input type="checkbox"/>	<input type="checkbox"/>	40.5#	\$ 481	\$ 32		
	20 x 36”	RZEEA2036-73P	<input type="checkbox"/>	<input type="checkbox"/>	43.0#	518	34		
	24 x 30”	RZEEA2430-73P	<input type="checkbox"/>	<input type="checkbox"/>	43.0#	492	34		
	24 x 36”	RZEEA2436-73P	<input type="checkbox"/>	<input type="checkbox"/>	45.0#	525	36		
RZEAA									
 <p>Adjustable Height Rectangular Square Corners, 21-32”H</p> <ul style="list-style-type: none"> Stack up to 4 high Unitized steel frame Ship fully assembled Casters and glides are interchangeable Legs adjust in 1” increments Legs are factory pre-set at 29”H 20x36 and 24x36 desk are ADA compliant 	20 x 30”	RZEEA2030-73P	<input type="checkbox"/>	<input type="checkbox"/>	42.0#	\$ 544	\$ 42		
	20 x 36”	RZEEA2036-73P	<input type="checkbox"/>	<input type="checkbox"/>	44.5#	592	44		
	24 x 30”	RZEEA2430-73P	<input type="checkbox"/>	<input type="checkbox"/>	44.5#	556	44		
	24 x 36”	RZEEA2436-73P	<input type="checkbox"/>	<input type="checkbox"/>	47.0#	596	46		
RZEEA									

A

B

C

D

E

HOW TO ORDER

- Indicate the following information on order form:
- Quantity of each item.
 - Model number, including options. See “How To Build a Model Number”.
 - Any special service required.

Note:

- The indicates that a choice is required.
- The absence of the indicates that no choice is required.
- Alpha-numeric characters in place of indicate that no other alternatives are available.

HOW TO BUILD A MODEL NUMBER

- A** Select basic model/edge style.
74P - 1-1/4” laminate top w/74P edge band
- B** Select edge color.
Refer to the **Product Color Options** page in this price list.
- C** Select surface finish.
Refer to the **Product Color Options** page in this price list.
- D** Select base finish.
Refer to the **Product Color Options** page in this price list.
- E** Select base option.

BCF	- Casters/felt glides
BCN	- Casters/nylon glides
GFT	- Felt glides
GNY	- Nylon glides
CCC	- Casters

SPECIAL SERVICES

Special Carton Marking

With specially marked information N/C

Shipping

Ships **assembled**, FOB **Bonduei, WI 54107**, **freight excluded**. Freight class 125.

Specifications and prices are subject to change without prior notice.

Ruckus® Post-Leg Desk (Freight Excluded Pricing)

3/4" Top - 73P Edge



Ruckus® Post-Leg Desk (Freight Excluded Pricing)

3/4" Top - 73P Edge

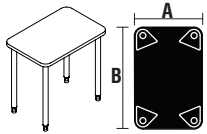
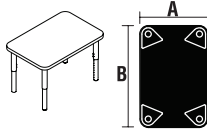
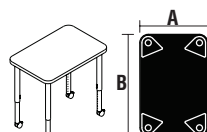
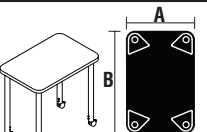
MODEL	A x B	MODEL NUMBER								Approx. Packaged Weight	Freight Excluded Pricing	Chrome Upcharge add to list price	Laminate Grade 2 add to list price	
		Basic Model/Edge Style	Edge Color	Surface Finish	Base Finish	Base Option	Under Table Storage	Book Basket Color	Book Box Color					
 <p>Fixed Height Rectangular Desk, 28-1/2" H</p> <ul style="list-style-type: none"> • Casters and glides are interchangeable • Ruckus post-leg desks require assembly • All corners of surface are rounded • Specify casters/glides to wheelbarrow 	20 x 30"	RDEEA2030-73P	<input type="checkbox"/>	<input type="checkbox"/>	<input type="checkbox"/>	<input type="checkbox"/>	42.8#	\$ 374	\$ 68	\$ 19				
	20 x 36"	RDEEA2036-73P	<input type="checkbox"/>	<input type="checkbox"/>	<input type="checkbox"/>	<input type="checkbox"/>	47.0#	394	68	19				
	24 x 36"	RDEEA2436-73P	<input type="checkbox"/>	<input type="checkbox"/>	<input type="checkbox"/>	<input type="checkbox"/>	52.0#	407	68	19				
RDEEA														
 <p>Floor Height Adjustable Rectangular Desk, 11-1/2 to 18-1/2" H</p> <ul style="list-style-type: none"> • Ruckus post-leg desks require assembly • All corners of surface are rounded • Legs adjust with screws in 1" increments • Legs are factory pre-set at 18-1/2" H • Base only available in glides 	20 x 30"	RDEHA2030-73P	<input type="checkbox"/>	<input type="checkbox"/>	<input type="checkbox"/>	<input type="checkbox"/>	40.3#	\$ 409	\$ 71	\$ 19				
	20 x 36"	RDEHA2036-73P	<input type="checkbox"/>	<input type="checkbox"/>	<input type="checkbox"/>	<input type="checkbox"/>	44.5#	421	71	19				
	24 x 36"	RDEHA2436-73P	<input type="checkbox"/>	<input type="checkbox"/>	<input type="checkbox"/>	<input type="checkbox"/>	49.5#	428	71	19				
RDEHA														
 <p>Sit Height Adjustable Rectangular Desk, 19-1/2 to 32-1/2" H</p> <ul style="list-style-type: none"> • Casters and glides are interchangeable • Ruckus post-leg desks require assembly • All corners of surface are rounded • Specify casters/glides to wheelbarrow • Legs adjust with screws in 1" increments • Legs are factory pre-set at 28-1/2" H • 20 x 37" desk is ADA compliant 	20 x 30"	RDEEA2030-73P	<input type="checkbox"/>	<input type="checkbox"/>	<input type="checkbox"/>	<input type="checkbox"/>	44.8#	\$ 422	\$ 74	\$ 19				
	20 x 36"	RDEEA2036-73P	<input type="checkbox"/>	<input type="checkbox"/>	<input type="checkbox"/>	<input type="checkbox"/>	49.0#	446	74	19				
	24 x 36"	RDEEA2436-73P	<input type="checkbox"/>	<input type="checkbox"/>	<input type="checkbox"/>	<input type="checkbox"/>	54.0#	454	74	19				
	20 x 37"	RDEEA2037ADA-73P	<input type="checkbox"/>	<input type="checkbox"/>	<input type="checkbox"/>	<input type="checkbox"/>	49.7#	506	74	19				
RDEEA														
 <p>Sit-Stand Height Adjustable Rectangular Desk, 28-1/2 to 41-1/2" H</p> <ul style="list-style-type: none"> • Casters and glides are interchangeable • Ruckus post-leg desks require assembly • All corners of surface are rounded • Specify casters/glides to wheelbarrow • Legs adjust with screws in 1" increments • Legs are factory pre-set at 28-1/2" H • 20 x 37" desk is ADA compliant 	20 x 30"	RDEFA2030-73P	<input type="checkbox"/>	<input type="checkbox"/>	<input type="checkbox"/>	<input type="checkbox"/>	48.8#	\$ 455	\$ 85	\$ 19				
	20 x 36"	RDEFA2036-73P	<input type="checkbox"/>	<input type="checkbox"/>	<input type="checkbox"/>	<input type="checkbox"/>	53.0#	470	85	19				
	24 x 36"	RDEFA2436-73P	<input type="checkbox"/>	<input type="checkbox"/>	<input type="checkbox"/>	<input type="checkbox"/>	58.0#	478	85	19				
	20 x 37"	RDEFA2037ADA-73P	<input type="checkbox"/>	<input type="checkbox"/>	<input type="checkbox"/>	<input type="checkbox"/>	53.7#	532	85	19				
RDEFA														

A B C D E F G H

HOW TO ORDER

- Indicate the following information on order form:
- Quantity of each item.
 - Model number, including options. See "How To Build a Model Number".
 - Any special service required.

Note: • The indicates that a choice is required.
 • The absence of the indicates that no choice is required.
 • Alpha-numeric characters in place of indicate that no other alternatives are available.

HOW TO BUILD A MODEL NUMBER

- A** Select basic model/edge style.
73P - 3/4" laminate top w/73P edge band
- B** Select edge color.
 Refer to the **Product Color Options** page in this price list.
- C** Select surface finish.
 Refer to the **Product Color Options** page in this price list.
- D** Select base finish.
 Refer to the **Product Color Options** page in this price list.
- E** Select base option.
BCF - Casters/felt glides
BCN - Casters/nylon glides
GFT - Felt glides
GNV - Nylon glides
CCC - Casters
 Base options for Floor Height Adjustable are

ONLY Felt glides - GFT and Nylon glides - GNV

- F** Select under table storage.
NB - No book storage
BBS - Poly book box, small; add \$30
BBL - Poly book box, large; add \$32
BR - Book basket; add \$42
RT - Removable storage tote; add \$47
SBBS - Steel book box, small; add \$68
SBBL - Steel book box, large; add \$78
 BBL & SBBL options are not available on the 20x30" desk sizes.
- G** Select book basket color.
 Refer to the **Product Color Options** page in this price list.
 Only if book basket (BR) storage is selected.
- H** Select steel book box color.
 Refer to the **Product Color Options** page in this price list.
 Only if steel book box (SBBS or SBBL) storage is selected.

FINISH INFORMATION

Additional Laminate Offering

KI offers laminates beyond those offered in the standard offering. Laminates that are currently available in the program can be viewed in KI product specification tools. Requests to add laminates to the program can be submitted via the product modification request process. Please note, requests to add laminates to the program must include the laminate manufacturer's name, color/pattern number, and finish code. Edge options are limited to standard edge colors. If a matching edge is required, this will need to be requested through the product modification request process and may be subject to additional costs. Due to varying manufacturing processes and quality issues with some laminates, some requests may be denied. Extended lead times and minimum order quantities may apply on orders containing special laminates. Contact the product modification team for questions or additional information regarding special laminates and pricing.

SPECIAL SERVICES

Special Carton Marking

With specially marked information N/C

Shipping
 Ships **knocked down, FOB Bonduel, WI 54107, freight excluded.** Freight class 70.

Specifications and prices are subject to change without prior notice.

Ruckus® Post-Leg Desk (Freight Excluded Pricing)

3/4" Top - 73P Edge



Ruckus® Post-Leg Desk (Freight Excluded Pricing)

3/4" Top - 73P Edge

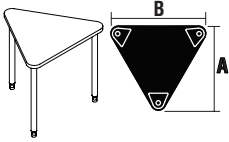
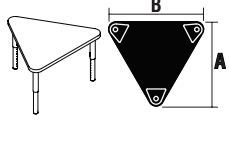
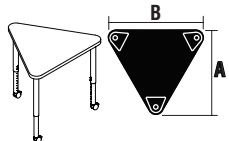
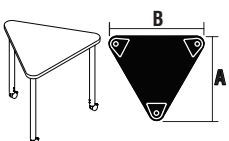
MODEL	Features	A x B	MODEL NUMBER								Approx. Packaged Weight	Freight Excluded Pricing	Chrome Upcharge add to list price	Laminate Grade 2 add to list price
			Basic Model/Edge Style	Edge Color	Surface Finish	Base Finish	Base Option	Under Table Storage	Book Basket Color	Book Box Color				
 RDEAK	Fixed Height E-Triangle Desk, 28-1/2" H • Casters and glides are interchangeable • Ruckus post-leg desks require assembly • All corners of surface are rounded • Specify casters/glides to wheelbarrow • 6 Desks combine to form an hexagon	Small 28 x 32"	RDEAK32-73P	<input type="checkbox"/>	<input type="checkbox"/>	<input type="checkbox"/>	<input type="checkbox"/>	<input type="checkbox"/>	<input type="checkbox"/>	<input type="checkbox"/>	29.0#	\$ 337	\$ 51	\$ 19
		Large 33 x 37"	RDEAK37-73P	<input type="checkbox"/>	<input type="checkbox"/>	<input type="checkbox"/>	<input type="checkbox"/>	<input type="checkbox"/>	<input type="checkbox"/>	<input type="checkbox"/>	<input type="checkbox"/>	33.0#	399	51
 RDEHK	Floor Height Adjustable E-Triangle Desk, 11-1/2" to 18-1/2" H • Ruckus post-leg desks require assembly • All corners of surface are rounded • Legs adjust with screws in 1" increments • Legs are factory pre-set at 18-1/2"H • 6 Desks combine to form an hexagon • Base only available in glides	Small 28 x 32"	RDEHK32-73P	<input type="checkbox"/>	<input type="checkbox"/>	<input type="checkbox"/>	<input type="checkbox"/>	<input type="checkbox"/>	<input type="checkbox"/>	<input type="checkbox"/>	27.2#	\$ 348	\$ 71	\$ 19
		Large 33 x 37"	RDEHK37-73P	<input type="checkbox"/>	<input type="checkbox"/>	<input type="checkbox"/>	<input type="checkbox"/>	<input type="checkbox"/>	<input type="checkbox"/>	<input type="checkbox"/>	<input type="checkbox"/>	31.1#	404	71
 RDEEK	Sit Height Adjustable E-Triangle Desk, 19-1/2 to 32-1/2" H • Casters and glides are interchangeable • Ruckus post-leg desks require assembly • All corners of surface are rounded • Specify casters/glides to wheelbarrow • Legs adjust with screws in 1" increments • Legs are factory pre-set at 28-1/2"H • 6 Desks combine to form an hexagon	Small 28 x 32"	RDEEK32-73P	<input type="checkbox"/>	<input type="checkbox"/>	<input type="checkbox"/>	<input type="checkbox"/>	<input type="checkbox"/>	<input type="checkbox"/>	<input type="checkbox"/>	30.5#	\$ 371	\$ 56	\$ 19
		Large 33 x 37"	RDEEK37-73P	<input type="checkbox"/>	<input type="checkbox"/>	<input type="checkbox"/>	<input type="checkbox"/>	<input type="checkbox"/>	<input type="checkbox"/>	<input type="checkbox"/>	<input type="checkbox"/>	34.5#	431	56
 RDEFK	Sit-Stand Height Adjustable E-Triangle Desk, 28-1/2 to 41-1/2" H • Casters and glides are interchangeable • Ruckus post-leg desks require assembly • All corners of surface are rounded • Specify casters/glides to wheelbarrow • Legs adjust with screws in 1" increments • Legs are factory pre-set at 28-1/2"H • 6 Desks combine to form an hexagon	Small 28 x 32"	RDEFK32-73P	<input type="checkbox"/>	<input type="checkbox"/>	<input type="checkbox"/>	<input type="checkbox"/>	<input type="checkbox"/>	<input type="checkbox"/>	<input type="checkbox"/>	33.5#	\$ 400	\$ 65	\$ 19
		Large 33 x 37"	RDEFK37-73P	<input type="checkbox"/>	<input type="checkbox"/>	<input type="checkbox"/>	<input type="checkbox"/>	<input type="checkbox"/>	<input type="checkbox"/>	<input type="checkbox"/>	<input type="checkbox"/>	37.5#	461	65

A **B** **C** **D** **E** **F** **G** **H**

HOW TO ORDER

- Indicate the following information on order form:
- Quantity of each item.
 - Model number, including options. See "How To Build a Model Number".
 - Any special service required.

Note: • The indicates that a choice is required.
 • The absence of the indicates that no choice is required.
 • Alpha-numeric characters in place of indicate that no other alternatives are available.

HOW TO BUILD A MODEL NUMBER

- A** Select basic model/edge style.
73P - 3/4" laminate top w/73P edge band
- B** Select edge color.
 Refer to the **Product Color Options** page in this price list.
- C** Select surface finish.
 Refer to the **Product Color Options** page in this price list.
- D** Select base finish.
 Refer to the **Product Color Options** page in this price list.
- E** Select base option.
GFT - Felt glides
GNV - Nylon glides
BCF - Casters/felt glides
BCN - Casters/nylon glides
CCC - Casters
 Base options for Floor Height Adjustable are

ONLY Felt glides - GFT and Nylon glides - GNV

- F** Select under table storage.
NB - No book storage
BBS - Poly book box, small; add \$30
BBL - Poly book box, large; add \$32
BR - Book basket; add \$42
RT - Removable storage tote; add \$47
SBBS - Steel book box, small; add \$68
SBBL - Steel book box, large; add \$78
 BBL & SBBL options are not available on the small desk sizes.
- G** Select book basket color.
 Refer to the **Product Color Options** page in this price list.
 Only if book basket (BR) storage is selected.
- H** Select steel book box color.
 Refer to the **Product Color Options** page in this price list.
 Only if steel book box (SBBS or SBBL) storage is selected.

FINISH INFORMATION

Additional Laminate Offering

KI offers laminates beyond those offered in the standard offering. Laminates that are currently available in the program can be viewed in KI product specification tools. Requests to add laminates to the program can be submitted via the product modification request process. Please note, requests to add laminates to the program must include the laminate manufacturer's name, color/pattern number, and finish code. Edge options are limited to standard edge colors. If a matching edge is required, this will need to be requested through the product modification request process and may be subject to additional costs. Due to varying manufacturing processes and quality issues with some laminates, some requests may be denied. Extended lead times and minimum order quantities may apply on orders containing special laminates. Contact the product modification team for questions or additional information regarding special laminates and pricing.

SPECIAL SERVICES

Special Carton Marking

With specially marked information N/C

Shipping

Ships knocked down, FOB Bonduel, WI 54107, freight excluded. Freight class 70.

Specifications and prices are subject to change without prior notice.

Ruckus® Post-Leg Desk (Freight Excluded Pricing)

3/4" Top - 73P Edge



Ruckus® Post-Leg Desk (Freight Excluded Pricing)

3/4" Top - 73P Edge

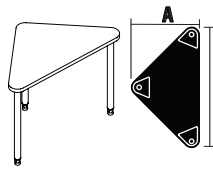
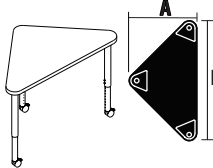
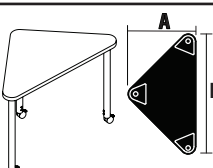
MODEL	Features	A x B	MODEL NUMBER								Approx. Packaged Weight	Freight Excluded Pricing	Chrome Upcharge add to list price	Laminate Grade 2 add to list price	
			Basic Model/Edge Style	Edge Color	Surface Finish	Base Finish	Base Option	Under Table Storage	Book Basket Color	Book Box Color					
 Fixed Height R-Triangle Desk, 28-1/2" H • Casters and glides are interchangeable • Ruckus post-leg desks require assembly • All corners of surface are rounded • Specify casters/glides to wheelbarrow • 4 Desks combine to form a square	Small	22 x 39"	RDEAL39-73P	<input type="checkbox"/>	<input type="checkbox"/>	<input type="checkbox"/>	<input type="checkbox"/>	<input type="checkbox"/>	<input type="checkbox"/>	<input type="checkbox"/>	29.0#	\$ 337	\$ 51	\$ 19	
	Large	26 x 47"	RDEAL47-73P	<input type="checkbox"/>	<input type="checkbox"/>	<input type="checkbox"/>	<input type="checkbox"/>	<input type="checkbox"/>	<input type="checkbox"/>	<input type="checkbox"/>	33.0#	346	51	27	
RDEAL															
 Sit Height Adjustable R-Triangle Desk, 19-1/2 to 32-1/2" H • Casters and glides are interchangeable • Ruckus post-leg desks require assembly • All corners of surface are rounded • Specify casters/glides to wheelbarrow • Legs adjust with screws in 1" increments • Legs are factory pre-set at 28-1/2"H • 4 Desks combine to form a square	Small	22 x 39"	RDEEL39-73P	<input type="checkbox"/>	<input type="checkbox"/>	<input type="checkbox"/>	<input type="checkbox"/>	<input type="checkbox"/>	<input type="checkbox"/>	<input type="checkbox"/>	30.5#	\$ 371	\$ 56	\$ 19	
	Large	26 x 47"	RDEEL47-73P	<input type="checkbox"/>	<input type="checkbox"/>	<input type="checkbox"/>	<input type="checkbox"/>	<input type="checkbox"/>	<input type="checkbox"/>	<input type="checkbox"/>	34.5#	379	56	27	
RDEEL															
 Sit-Stand Height Adjustable R-Triangle Desk, 28-1/2 to 41-1/2" H • Casters and glides are interchangeable • Ruckus post-leg desks require assembly • All corners of surface are rounded • Specify casters/glides to wheelbarrow • Legs adjust with screws in 1" increments • Legs are factory pre-set at 28-1/2"H • 4 Desks combine to form a square	Small	22 x 39"	RDEFL39-73P	<input type="checkbox"/>	<input type="checkbox"/>	<input type="checkbox"/>	<input type="checkbox"/>	<input type="checkbox"/>	<input type="checkbox"/>	<input type="checkbox"/>	33.5#	\$ 400	\$ 65	\$ 19	
	Large	26 x 47"	RDEFL47-73P	<input type="checkbox"/>	<input type="checkbox"/>	<input type="checkbox"/>	<input type="checkbox"/>	<input type="checkbox"/>	<input type="checkbox"/>	<input type="checkbox"/>	37.5#	410	65	27	
RDEFL															

A **B** **C** **D** **E** **F** **G** **H**

HOW TO ORDER

- Indicate the following information on order form:
- Quantity of each item.
 - Model number, including options. See "How To Build a Model Number".
 - Any special service required.

Note: • The indicates that a choice is required.
 • The absence of the indicates that no choice is required.
 • Alpha-numeric characters in place of indicate that no other alternatives are available.

HOW TO BUILD A MODEL NUMBER

- A** Select basic model/edge style.
73P - 3/4" laminate top w/73P edge band
- B** Select edge color.
 Refer to the **Product Color Options** page in this price list.
- C** Select surface finish.
 Refer to the **Product Color Options** page in this price list.
- D** Select base finish.
 Refer to the **Product Color Options** page in this price list.
- E** Select base option.
BCF - Casters/felt glides
BCN - Casters/nylon glides
GFT - Felt glides
GNY - Nylon glides
CCC - Casters

- F** Select under table storage.
NB - No book storage
BBS - Poly book box, small; add \$30
BBL - Poly book box, large; add \$32
BR - Book basket; add \$42
RT - Removable storage tote; add \$47
SBBS - Steel book box, small; add \$68
SBBL - Steel book box, large; add \$78
 BBL & SBBL options are not available on the small desk sizes.
- G** Select book basket color.
 Refer to the **Product Color Options** page in this price list.
 Only if book basket (BR) storage is selected.
- H** Select steel book box color.
 Refer to the **Product Color Options** page in this price list.
 Only if steel book box (SBBS or SBBL) storage is selected.

FINISH INFORMATION

Additional Laminate Offering
 KI offers laminates beyond those offered in the standard offering. Laminates that are currently available in the program can be viewed in KI product specification tools. Requests to add laminates to the program can be submitted via the product modification request process. Please note, requests to add laminates to the program must include the laminate manufacturer's name, color/pattern number, and finish code. Edge options are limited to standard edge colors. If a matching edge is required, this will need to be requested through the product modification request process and may be subject to additional costs. Due to varying manufacturing processes and quality issues with some laminates, some requests may be denied. Extended lead times and minimum order quantities may apply on orders containing special laminates. Contact the product modification team for questions or additional information regarding special laminates and pricing.

SPECIAL SERVICES

Special Carton Marking
 With specially marked information N/C

Shipping
 Ships **knocked down, FOB Bonduel, WI 54107, freight excluded**. Freight class 70.

Specifications and prices are subject to change without prior notice.

Ruckus® Post-Leg Desk (Freight Excluded Pricing)

3/4" Top - 73P Edge



Ruckus® Post-Leg Desk (Freight Excluded Pricing)

3/4" Top - 73P Edge

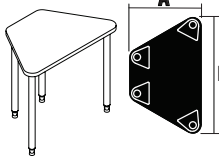
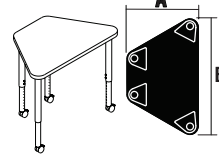
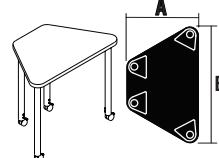
MODEL	Features	A x B	MODEL NUMBER								Approx. Packaged Weight	Freight Excluded Pricing	Chrome Upcharge add to list price	Laminate Grade 2 add to list price	
			Basic Model/Edge Style	Edge Color	Surface Finish	Base Finish	Base Option	Under Table Storage	Book Basket Color	Book Box Color					
 RDEAM Fixed Height Trapezoid Desk, 28-1/2" H • Casters and glides are interchangeable • Ruckus post-leg desks require assembly • All corners of surface are rounded • Specify casters/glides to wheelbarrow • 6 Desks combine to form a hexagon	Small	21 x 34"	RDEAM34-73P	<input type="checkbox"/>	<input type="checkbox"/>	<input type="checkbox"/>	<input type="checkbox"/>	<input type="checkbox"/>	<input type="checkbox"/>	<input type="checkbox"/>	<input type="checkbox"/>	35.0#	\$ 370	\$ 68	\$ 19
	Large	24 x 37"	RDEAM37-73P	<input type="checkbox"/>	<input type="checkbox"/>	<input type="checkbox"/>	<input type="checkbox"/>	<input type="checkbox"/>	<input type="checkbox"/>	<input type="checkbox"/>	<input type="checkbox"/>	38.0#	394	68	19
 RDEEM Sit Height Adjustable Trapezoid Desk, 19-1/2 to 32-1/2" H • Casters and glides are interchangeable • Ruckus post-leg desks require assembly • All corners of surface are rounded • Specify casters/glides to wheelbarrow • Legs adjust with screws in 1" increments • Legs are factory pre-set at 28-1/2"H • 6 Desks combine to form a hexagon	Small	21 x 34"	RDEEM34-73P	<input type="checkbox"/>	<input type="checkbox"/>	<input type="checkbox"/>	<input type="checkbox"/>	<input type="checkbox"/>	<input type="checkbox"/>	<input type="checkbox"/>	<input type="checkbox"/>	37.0#	\$ 420	\$ 74	\$ 19
	Large	24 x 37"	RDEEM37-73P	<input type="checkbox"/>	<input type="checkbox"/>	<input type="checkbox"/>	<input type="checkbox"/>	<input type="checkbox"/>	<input type="checkbox"/>	<input type="checkbox"/>	<input type="checkbox"/>	40.0#	444	74	19
 RDEFM Sit-Stand Height Adjustable Trapezoid Desk, 28-1/2 to 41-1/2" H • Casters and glides are interchangeable • Ruckus post-leg desks require assembly • All corners of surface are rounded • Specify casters/glides to wheelbarrow • Legs adjust with screws in 1" increments • Legs are factory pre-set at 28-1/2"H • 6 Desks combine to form a hexagon	Small	21 x 34"	RDEFM34-73P	<input type="checkbox"/>	<input type="checkbox"/>	<input type="checkbox"/>	<input type="checkbox"/>	<input type="checkbox"/>	<input type="checkbox"/>	<input type="checkbox"/>	<input type="checkbox"/>	41.0#	\$ 454	\$ 85	\$ 19
	Large	24 x 37"	RDEFM37-73P	<input type="checkbox"/>	<input type="checkbox"/>	<input type="checkbox"/>	<input type="checkbox"/>	<input type="checkbox"/>	<input type="checkbox"/>	<input type="checkbox"/>	<input type="checkbox"/>	44.0#	479	85	19

A **B** **C** **D** **E** **F** **G** **H**

HOW TO ORDER

- Indicate the following information on order form:
- Quantity of each item.
 - Model number, including options. See "How To Build a Model Number".
 - Any special service required.

Note: • The indicates that a choice is required.
 • The absence of the indicates that no choice is required.
 • Alpha-numeric characters in place of indicate that no other alternatives are available.

HOW TO BUILD A MODEL NUMBER

- A** Select basic model/edge style.
73P - 3/4" laminate top w/73P edge band
- B** Select edge color.
 Refer to the **Product Color Options** page in this price list.
- C** Select surface finish.
 Refer to the **Product Color Options** page in this price list.
- D** Select base finish.
 Refer to the **Product Color Options** page in this price list.
- E** Select base option.
BCF - Casters/felt glides
BCN - Casters/nylon glides
GFT - Felt glides
GNY - Nylon glides
CCC - Casters

- F** Select under table storage.
NB - No book storage
BBS - Poly book box, small; add \$30
BBL - Poly book box, large; add \$32
BR - Book basket; add \$42
RT - Removable storage tote; add \$47
SBBS - Steel book box, small; add \$68
SBBL - Steel book box, large; add \$78
 BBL & SBBL options are not available on the small desk sizes.
- G** Select book basket color.
 Refer to the **Product Color Options** page in this price list.
 Only if book basket (BR) storage is selected.
- H** Select steel book box color.
 Refer to the **Product Color Options** page in this price list.
 Only if steel book box (SBBS or SBBL) storage is selected.

FINISH INFORMATION

Additional Laminate Offering

KI offers laminates beyond those offered in the standard offering. Laminates that are currently available in the program can be viewed in KI product specification tools. Requests to add laminates to the program can be submitted via the product modification request process. Please note, requests to add laminates to the program must include the laminate manufacturer's name, color/pattern number, and finish code. Edge options are limited to standard edge colors. If a matching edge is required, this will need to be requested through the product modification request process and may be subject to additional costs. Due to varying manufacturing processes and quality issues with some laminates, some requests may be denied. Extended lead times and minimum order quantities may apply on orders containing special laminates. Contact the product modification team for questions or additional information regarding special laminates and pricing.

SPECIAL SERVICES

Special Carton Marking

With specially marked information N/C

Shipping

Ships **knocked down, FOB Bonduel, WI 54107, freight excluded.** Freight class 70.

Specifications and prices are subject to change without prior notice.

Ruckus® Post-Leg Desk (Freight Excluded Pricing)

3/4" Top - 73P Edge



Ruckus® Post-Leg Desk (Freight Excluded Pricing)

3/4" Top - 73P Edge

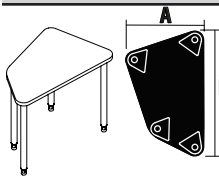
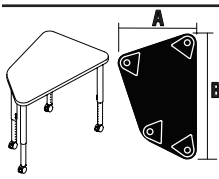
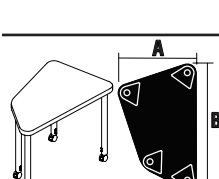
MODEL	Features	A x B	MODEL NUMBER								Approx. Packaged Weight	Freight Excluded Pricing	Chrome Upcharge add to list price	Laminate Grade 2 add to list price	
			Basic Model/Edge Style	Edge Color	Surface Finish	Base Finish	Base Option	Under Table Storage	Book Basket Color	Book Box Color					
 RDEAZ Fixed Height Oddquad Desk, 28-1/2" H • Casters and glides are interchangeable • Ruckus post-leg desks require assembly • All corners of surface are rounded • Specify casters/glides to wheelbarrow • 4 Desks combine to form a pin-wheel	Small	22 x 36"	RDEAZ36-73P	<input type="checkbox"/>	<input type="checkbox"/>	<input type="checkbox"/>	<input type="checkbox"/>	<input type="checkbox"/>	<input type="checkbox"/>	<input type="checkbox"/>	<input type="checkbox"/>	35.0#	\$ 387	\$ 68	\$ 19
	Large	24 x 39"	RDEAZ39-73P	<input type="checkbox"/>	<input type="checkbox"/>	<input type="checkbox"/>	<input type="checkbox"/>	<input type="checkbox"/>	<input type="checkbox"/>	<input type="checkbox"/>	<input type="checkbox"/>	38.0#	394	68	19
 RDEEZ Sit Height Adjustable Oddquad Desk, 19-1/2 to 32-1/2" H • Casters and glides are interchangeable • Ruckus post-leg desks require assembly • All corners of surface are rounded • Specify casters/glides to wheelbarrow • Legs adjust with screws in 1" increments • Legs are factory pre-set at 28-1/2"H • 4 Desks combine to form a pin-wheel	Small	22 x 36"	RDEEZ36-73P	<input type="checkbox"/>	<input type="checkbox"/>	<input type="checkbox"/>	<input type="checkbox"/>	<input type="checkbox"/>	<input type="checkbox"/>	<input type="checkbox"/>	<input type="checkbox"/>	37.0#	\$ 433	\$ 74	\$ 19
	Large	24 x 39"	RDEEZ39-73P	<input type="checkbox"/>	<input type="checkbox"/>	<input type="checkbox"/>	<input type="checkbox"/>	<input type="checkbox"/>	<input type="checkbox"/>	<input type="checkbox"/>	<input type="checkbox"/>	40.0#	444	74	19
 RDEFZ Sit-Stand Height Adjustable Oddquad Desk, 28-1/2 to 41-1/2" H • Casters and glides are interchangeable • Ruckus post-leg desks require assembly • All corners of surface are rounded • Specify casters/glides to wheelbarrow • Legs adjust with screws in 1" increments • Legs are factory pre-set at 28-1/2"H • 4 Desks combine to form a pin-wheel	Small	22 x 36"	RDEFZ36-73P	<input type="checkbox"/>	<input type="checkbox"/>	<input type="checkbox"/>	<input type="checkbox"/>	<input type="checkbox"/>	<input type="checkbox"/>	<input type="checkbox"/>	<input type="checkbox"/>	41.0#	\$ 469	\$ 85	\$ 19
	Large	24 x 39"	RDEFZ39-73P	<input type="checkbox"/>	<input type="checkbox"/>	<input type="checkbox"/>	<input type="checkbox"/>	<input type="checkbox"/>	<input type="checkbox"/>	<input type="checkbox"/>	<input type="checkbox"/>	44.0#	479	85	19

A B C D E F G H

HOW TO ORDER

- Indicate the following information on order form:
- Quantity of each item.
 - Model number, including options. See "How to Build a Model Number".
 - Any special service required.

Note: • The indicates that a choice is required.
 • The absence of the indicates that no choice is required.
 • Alpha-numeric characters in place of indicate that no other alternatives are available.

HOW TO BUILD A MODEL NUMBER

- A** Select basic model/edge style.
73P - 3/4" laminate top w/73P edge band
- B** Select edge color.
 Refer to the **Product Color Options** page in this price list.
- C** Select surface finish.
 Refer to the **Product Color Options** page in this price list.
- D** Select base finish.
 Refer to the **Product Color Options** page in this price list.
- E** Select base option.
BCF - Casters/felt glides
BCN - Casters/nylon glides
GFT - Felt glides
GNY - Nylon glides
CCC - Casters

- F** Select under table storage.
NB - No book storage
BBS - Poly book box, small; add \$30
BBL - Poly book box, large; add \$32
BR - Book basket; add \$42
RT - Removable storage tote; add \$47
SBBS - Steel book box, small; add \$68
SBBL - Steel book box, large; add \$78
 BBL & SBBL options are not available on the small desk sizes.
- G** Select book basket color.
 Refer to the **Product Color Options** page in this price list.
 Only if book basket (BR) storage is selected.
- H** Select steel book box color.
 Refer to the **Product Color Options** page in this price list.
 Only if steel book box (SBBS or SBBL) storage is selected.

FINISH INFORMATION

Additional Laminate Offering
 KI offers laminates beyond those offered in the standard offering. Laminates that are currently available in the program can be viewed in KI product specification tools. Requests to add laminates to the program can be submitted via the product modification request process. Please note, requests to add laminates to the program must include the laminate manufacturer's name, color/pattern number, and finish code. Edge options are limited to standard edge colors. If a matching edge is required, this will need to be requested through the product modification request process and may be subject to additional costs. Due to varying manufacturing processes and quality issues with some laminates, some requests may be denied. Extended lead times and minimum order quantities may apply on orders containing special laminates. Contact the product modification team for questions or additional information regarding special laminates and pricing.

SPECIAL SERVICES

Special Carton Marking

With specially marked information N/C

Shipping
 Ships **knocked down, FOB Bonduel, WI 54107, freight excluded.** Freight class 70.

Specifications and prices are subject to change without prior notice.

Ruckus® Post-Leg Desk (Freight Excluded Pricing)

3/4" Top - 73P Edge



Ruckus® Post-Leg Desk (Freight Excluded Pricing)

3/4" Top - 73P Edge

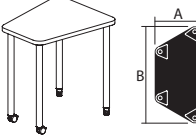
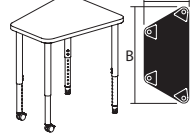
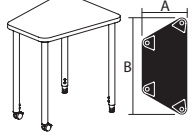
MODEL	A x B	MODEL NUMBER								Approx. Packaged Weight	Freight Excluded Pricing	Chrome Upcharge add to list price	Laminate Grade 2 add to list price	
		Basic Model/Edge Style	Edge Color	Surface Finish	Base Finish	Base Option	Under Table Storage	Book Basket Color	Book Box Color					
 <p>Fixed Height Pentaquad Desk, 28-1/2" H • Casters and glides are interchangeable • Ruckus post leg desks require assembly • All corners of surface are rounded • Specify casters/glides to wheelbarrow • Configures into pods of four or five desks</p>	26 x 30"	RDEAS2630-73P	<input type="checkbox"/>	<input type="checkbox"/>	<input type="checkbox"/>	<input type="checkbox"/>	<input type="checkbox"/>	<input type="checkbox"/>	<input type="checkbox"/>	<input type="checkbox"/>	58.00#	\$ 388	\$ 68	\$ 27
RDEAS														
 <p>Sit Height Adjustable Pentaquad Desk, 19-1/2 to 32-1/2" H • Casters and glides are interchangeable • Ruckus post leg desks require assembly • All corners of surface are rounded • Specify casters/glides to wheelbarrow • Legs adjust with screws in 1" increments • Legs are factory pre-set at 28.5"H • Configures into pods of four or five desks</p>	26 x 30"	RDEES2630-73P	<input type="checkbox"/>	<input type="checkbox"/>	<input type="checkbox"/>	<input type="checkbox"/>	<input type="checkbox"/>	<input type="checkbox"/>	<input type="checkbox"/>	<input type="checkbox"/>	60.00#	\$ 444	\$ 74	\$ 27
RDEES														
 <p>Sit-Stand Height Adjustable Pentaquad Desk, 28-1/2 to 41-1/2" • Casters and glides are interchangeable • Ruckus post leg desks require assembly • All corners of surface are rounded • Specify casters/glides to wheelbarrow • Legs adjust with screws in 1" increments • Legs are factory pre-set at 28.5"H • Configures into pods of four or five desks</p>	26 x 30"	RDEFS2630-73P	<input type="checkbox"/>	<input type="checkbox"/>	<input type="checkbox"/>	<input type="checkbox"/>	<input type="checkbox"/>	<input type="checkbox"/>	<input type="checkbox"/>	<input type="checkbox"/>	64.00#	\$ 479	\$ 85	\$ 27
RDEFS														
			A	B	C	D	E	F	G	H				

HOW TO ORDER

- Indicate the following information on order form:
- Quantity of each item.
 - Model number, including options. See "How To Build a Model Number".
 - Any special service required.

Note: • The indicates that a choice is required.

- The absence of the indicates that no choice is required.
- Alpha-numeric characters in place of indicate that no other alternatives are available.

HOW TO BUILD A MODEL NUMBER

- A** Select basic model/edge style.
73P - 3/4" laminate top w/73P edge band
- B** Select edge color.
 Refer to the **Product Color Options** page in this price list.
- C** Select surface finish.
 Refer to the **Product Color Options** page in this price list.
- D** Select base finish.
 Refer to the **Product Color Options** page in this price list.
- E** Select base option.
BCF - Casters/felt glides
BCN - Casters/nylon glides
GFT - Felt glides
GNY - Nylon glides
CCC - Casters

- F** Select under table storage.
NB - No book storage
BBS - Poly book box, small; add \$30
BBL - Poly book box, large; add \$32
BR - Book basket; add \$42
RT - Removable storage tote; add \$47
SBBS - Steel book box, small; add \$68
SBBL - Steel book box, large; add \$78
 BBL & SBBL options are not available on the small desk sizes.
- G** Select book basket color.
 Refer to the **Product Color Options** page in this price list.
 Only if book basket (BR) storage is selected.
- H** Select steel book box color.
 Refer to the **Product Color Options** page in this price list.
 Only if steel book box (SBBS or SBBL) storage is selected.

FINISH INFORMATION

Additional Laminate Offering

KI offers laminates beyond those offered in the standard offering. Laminates that are currently available in the program can be viewed in KI product specification tools. Requests to add laminates to the program can be submitted via the product modification request process. Please note, requests to add laminates to the program must include the laminate manufacturer's name, color/pattern number, and finish code. Edge options are limited to standard edge colors. If a matching edge is required, this will need to be requested through the product modification request process and may be subject to additional costs. Due to varying manufacturing processes and quality issues with some laminates, some requests may be denied. Extended lead times and minimum order quantities may apply on orders containing special laminates. Contact the product modification team for questions or additional information regarding special laminates and pricing.

SPECIAL SERVICES

Special Carton Marking

With specially marked information N/C

Shipping

Ships **knocked down**, **FOB Bonduel, WI 54107**, **freight excluded**. Freight class 70.

Specifications and prices are subject to change without prior notice.

Ruckus® Post-Leg Desk (Freight Excluded Pricing)

1-1/4" Top - 74P Edge



Ruckus® Post-Leg Desk (Freight Excluded Pricing)

1-1/4" Top - 74P Edge

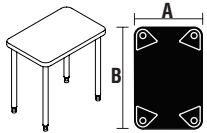
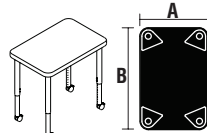
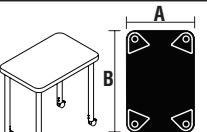
MODEL	A x B	MODEL NUMBER								Approx. Packaged Weight	Freight Excluded Pricing	Chrome Upcharge add to list price	Laminate Grade 2 add to list price	
		Basic Model/Edge Style	Edge Color	Surface Finish	Base Finish	Base Option	Under Table Storage	Book Basket Color	Book Box Color					
 <p>Fixed Height Rectangular Desk, 29" H</p> <ul style="list-style-type: none"> • Casters and glides are interchangeable • Ruckus post-leg desks require assembly • All corners of surface are rounded • Specify casters/glides to wheelbarrow 	20 x 30"	RDEEA2030-74P	<input type="checkbox"/>	<input type="checkbox"/>	<input type="checkbox"/>	<input type="checkbox"/>	42.8#	\$ 427	\$ 68	\$ 19				
	20 x 36"	RDEEA2036-74P	<input type="checkbox"/>	<input type="checkbox"/>	<input type="checkbox"/>	<input type="checkbox"/>	47.0#	459	68	19				
	24 x 36"	RDEEA2436-74P	<input type="checkbox"/>	<input type="checkbox"/>	<input type="checkbox"/>	<input type="checkbox"/>	52.0#	470	68	19				
RDEEA														
 <p>Sit Height Adjustable Rectangular Desk, 20 to 33" H</p> <ul style="list-style-type: none"> • Casters and glides are interchangeable • Ruckus post-leg desks require assembly • All corners of surface are rounded • Specify casters/glides to wheelbarrow • Legs adjust with screws in 1" increments • Legs are factory pre-set at 29"H • 20 x 37" desk is ADA compliant 	20 x 30"	RDEEA2030-74P	<input type="checkbox"/>	<input type="checkbox"/>	<input type="checkbox"/>	<input type="checkbox"/>	44.8#	\$ 473	\$ 74	\$ 19				
	20 x 36"	RDEEA2036-74P	<input type="checkbox"/>	<input type="checkbox"/>	<input type="checkbox"/>	<input type="checkbox"/>	49.0#	506	74	19				
	24 x 36"	RDEEA2436-74P	<input type="checkbox"/>	<input type="checkbox"/>	<input type="checkbox"/>	<input type="checkbox"/>	54.0#	513	74	19				
	20 x 37"	RDEEA2037ADA-74P	<input type="checkbox"/>	<input type="checkbox"/>	<input type="checkbox"/>	<input type="checkbox"/>	49.7#	524	74	19				
RDEEA														
 <p>Sit-Stand Height Adjustable Rectangular Desk, 29 to 42" H</p> <ul style="list-style-type: none"> • Casters and glides are interchangeable • Ruckus post-leg desks require assembly • All corners of surface are rounded • Specify casters/glides to wheelbarrow • Legs adjust with screws in 1" increments • Legs are factory pre-set at 29"H • 20 x 37" desk is ADA compliant 	20 x 30"	RDEFA2030-74P	<input type="checkbox"/>	<input type="checkbox"/>	<input type="checkbox"/>	<input type="checkbox"/>	48.8#	\$ 510	\$ 85	\$ 19				
	20 x 36"	RDEFA2036-74P	<input type="checkbox"/>	<input type="checkbox"/>	<input type="checkbox"/>	<input type="checkbox"/>	53.0#	532	85	19				
	24 x 36"	RDEFA2436-74P	<input type="checkbox"/>	<input type="checkbox"/>	<input type="checkbox"/>	<input type="checkbox"/>	58.0#	540	85	19				
	20 x 37"	RDEFA2037ADA-74P	<input type="checkbox"/>	<input type="checkbox"/>	<input type="checkbox"/>	<input type="checkbox"/>	53.7#	551	85	19				
RDEFA														

A B C D E F G H

HOW TO ORDER

- Indicate the following information on order form:
1. Quantity of each item.
 2. Model number, including options. See "How To Build a Model Number".
 3. Any special service required.

Note: • The indicates that a choice is required.

- The absence of the indicates that no choice is required.
- Alpha-numeric characters in place of indicate that no other alternatives are available.

HOW TO BUILD A MODEL NUMBER

- A** Select basic model/edge style.
74P - 1-1/4" laminate top w/74P edge band
- B** Select edge color.
 Refer to the **Product Color Options** page in this price list.
- C** Select surface finish.
 Refer to the **Product Color Options** page in this price list.
- D** Select base finish.
 Refer to the **Product Color Options** page in this price list.
- E** Select base option.
BCF - Casters/felt glides
BCN - Casters/nylon glides
GFT - Felt glides
GNY - Nylon glides
CCC - Casters

- F** Select under table storage.
NB - No book storage
BBS - Poly book box, small; add \$30
BBL - Poly book box, large; add \$32
BR - Book basket; add \$42
RT - Removable storage tote; add \$47
SBBS - Steel book box, small; add \$68
SBBL - Steel book box, large; add \$78
 BBL & SBBL options are not available on the small desk sizes.
- G** Select book basket color.
 Refer to the **Product Color Options** page in this price list.
 Only if book basket (BR) storage is selected.
- H** Select steel book box color.
 Refer to the **Product Color Options** page in this price list.
 Only if steel book box (SBBS or SBBL) storage is selected.

FINISH INFORMATION

Additional Laminate Offering

KI offers laminates beyond those offered in the standard offering. Laminates that are currently available in the program can be viewed in KI product specification tools. Requests to add laminates to the program can be submitted via the product modification request process. Please note, requests to add laminates to the program must include the laminate manufacturer's name, color/pattern number, and finish code. Edge options are limited to standard edge colors. If a matching edge is required, this will need to be requested through the product modification request process and may be subject to additional costs. Due to varying manufacturing processes and quality issues with some laminates, some requests may be denied. Extended lead times and minimum order quantities may apply on orders containing special laminates. Contact the product modification team for questions or additional information regarding special laminates and pricing.

SPECIAL SERVICES

Special Carton Marking

With specially marked information N/C

Shipping

Ships **knocked down, FOB Bonduel, WI 54107, freight excluded**. Freight class 70.

Specifications and prices are subject to change without prior notice.

Ruckus® Post-Leg Desk (Freight Excluded Pricing)

1-1/4" Top - 74P Edge



Ruckus® Post-Leg Desk (Freight Excluded Pricing)

1-1/4" Top - 74P Edge

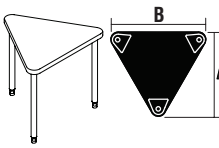
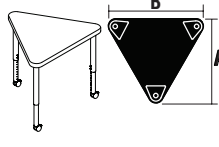
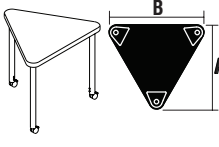
MODEL	Features	A x B	MODEL NUMBER								Approx. Packaged Weight	Freight Excluded Pricing	Chrome Upcharge add to list price	Laminate Grade 2 add to list price	
			Basic Model/Edge Style	Edge Color	Surface Finish	Base Finish	Base Option	Under Table Storage	Book Basket Color	Book Box Color					
 RDEAK	Fixed Height E-Triangle Desk, 29" H • Casters and glides are interchangeable • Ruckus post-leg desks require assembly • All corners of surface are rounded • Specify casters/glides to wheelbarrow • 6 Desks combine to form an hexagon	Small 28 x 32"	RDEAK32-74P	<input type="checkbox"/>	<input type="checkbox"/>	<input type="checkbox"/>	<input type="checkbox"/>	<input type="checkbox"/>	<input type="checkbox"/>	<input type="checkbox"/>	<input type="checkbox"/>	29.0#	\$ 418	\$ 51	\$ 27
		Large 33 x 37"	RDEAK37-74P	<input type="checkbox"/>	<input type="checkbox"/>	<input type="checkbox"/>	<input type="checkbox"/>	<input type="checkbox"/>	<input type="checkbox"/>	<input type="checkbox"/>	<input type="checkbox"/>	<input type="checkbox"/>	33.0#	482	51
 RDEEK	Sit Height Adjustable E-Triangle Desk, 20 to 33" H • Casters and glides are interchangeable • Ruckus post-leg desks require assembly • All corners of surface are rounded • Specify casters/glides to wheelbarrow • Legs adjust with screws in 1" increments • Legs are factory pre-set at 29"H • 6 Desks combine to form an hexagon	Small 28 x 32"	RDEEK32-74P	<input type="checkbox"/>	<input type="checkbox"/>	<input type="checkbox"/>	<input type="checkbox"/>	<input type="checkbox"/>	<input type="checkbox"/>	<input type="checkbox"/>	<input type="checkbox"/>	30.5#	\$ 450	\$ 56	\$ 27
		Large 33 x 37"	RDEEK37-74P	<input type="checkbox"/>	<input type="checkbox"/>	<input type="checkbox"/>	<input type="checkbox"/>	<input type="checkbox"/>	<input type="checkbox"/>	<input type="checkbox"/>	<input type="checkbox"/>	<input type="checkbox"/>	34.5#	512	56
 RDEFK	Sit-Stand Height Adjustable E-Triangle Desk, 29 to 42" H • Casters and glides are interchangeable • Ruckus post-leg desks require assembly • All corners of surface are rounded • Specify casters/glides to wheelbarrow • Legs adjust with screws in 1" increments • Legs are factory pre-set at 29"H • 6 Desks combine to form an hexagon	Small 28 x 32"	RDEFK32-74P	<input type="checkbox"/>	<input type="checkbox"/>	<input type="checkbox"/>	<input type="checkbox"/>	<input type="checkbox"/>	<input type="checkbox"/>	<input type="checkbox"/>	<input type="checkbox"/>	33.5#	\$ 482	\$ 65	\$ 27
		Large 33 x 37"	RDEFK37-74P	<input type="checkbox"/>	<input type="checkbox"/>	<input type="checkbox"/>	<input type="checkbox"/>	<input type="checkbox"/>	<input type="checkbox"/>	<input type="checkbox"/>	<input type="checkbox"/>	<input type="checkbox"/>	37.5#	547	65

A **B** **C** **D** **E** **F** **G** **H**

HOW TO ORDER

- Indicate the following information on order form:
- Quantity of each item.
 - Model number, including options. See "How To Build a Model Number".
 - Any special service required.

Note: • The indicates that a choice is required.
 • The absence of the indicates that no choice is required.
 • Alpha-numeric characters in place of indicate that no other alternatives are available.

HOW TO BUILD A MODEL NUMBER

- A** Select basic model/edge style.
74P - 1-1/4" laminate top w/74P edge band
- B** Select edge color.
 Refer to the **Product Color Options** page in this price list.
- C** Select surface finish.
 Refer to the **Product Color Options** page in this price list.
- D** Select base finish.
 Refer to the **Product Color Options** page in this price list.
- E** Select base option.
BCF - Casters/felt glides
BCN - Casters/nylon glides
GFT - Felt glides
GNY - Nylon glides
CCC - Casters

- F** Select under table storage.
NB - No book storage
BBS - Poly book box, small; add \$30
BBL - Poly book box, large; add \$32
BR - Book basket; add \$42
RT - Removable storage tote; add \$47
SBBS - Steel book box, small; add \$68
SBBL - Steel book box, large; add \$78
 BBL & SBBL options are not available on the small desk sizes.
- G** Select book basket color.
 Refer to the **Product Color Options** page in this price list.
 Only if book basket (BR) storage is selected.
- H** Select steel book box color.
 Refer to the **Product Color Options** page in this price list.
 Only if steel book box (SBBS or SBBL) storage is selected.

FINISH INFORMATION

Additional Laminate Offering
 KI offers laminates beyond those offered in the standard offering. Laminates that are currently available in the program can be viewed in KI product specification tools. Requests to add laminates to the program can be submitted via the product modification request process. Please note, requests to add laminates to the program must include the laminate manufacturer's name, color/pattern number, and finish code. Edge options are limited to standard edge colors. If a matching edge is required, this will need to be requested through the product modification request process and may be subject to additional costs. Due to varying manufacturing processes and quality issues with some laminates, some requests may be denied. Extended lead times and minimum order quantities may apply on orders containing special laminates. Contact the product modification team for questions or additional information regarding special laminates and pricing.

SPECIAL SERVICES

Special Carton Marking
 With specially marked information N/C

Shipping
 Ships **knocked down, FOB Bonduel, WI 54107, freight excluded.** Freight class 70.

Specifications and prices are subject to change without prior notice.

Ruckus® Post-Leg Desk (Freight Excluded Pricing)

1-1/4" Top - 74P Edge



Ruckus® Post-Leg Desk (Freight Excluded Pricing)

1-1/4" Top - 74P Edge

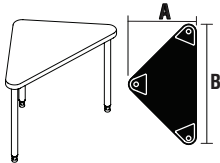
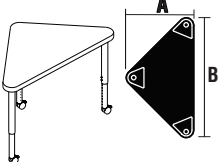
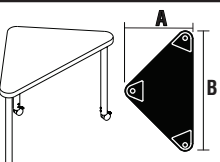
MODEL	Features	A x B	MODEL NUMBER								Approx. Packaged Weight	Freight Excluded Pricing	Chrome Upcharge add to list price	Laminate Grade 2 add to list price
			Basic Model/Edge Style	Edge Color	Surface Finish	Base Finish	Base Option	Under Table Storage	Book Basket Color	Book Box Color				
 Fixed Height R-Triangle Desk, 29" H • Casters and glides are interchangeable • Ruckus post-leg desks require assembly • All corners of surface are rounded • Specify casters/glides to wheelbarrow • 4 Desks combine to form a square RDEAL	Small	22 x 39"	RDEAL39-74P	<input type="checkbox"/>	<input type="checkbox"/>	<input type="checkbox"/>	<input type="checkbox"/>	<input type="checkbox"/>	<input type="checkbox"/>	<input type="checkbox"/>	29.0#	\$ 413	\$ 51	\$ 19
	Large	26 x 47"	RDEAL47-74P	<input type="checkbox"/>	<input type="checkbox"/>	<input type="checkbox"/>	<input type="checkbox"/>	<input type="checkbox"/>	<input type="checkbox"/>	<input type="checkbox"/>	33.0#	444	51	27
 Sit Height Adjustable R-Triangle Desk, 20 to 33" H • Casters and glides are interchangeable • Ruckus post-leg desks require assembly • All corners of surface are rounded • Specify casters/glides to wheelbarrow • Legs adjust with screws in 1" increments • Legs are factory pre-set at 29"H • 4 Desks combine to form a square RDEEL	Small	22 x 39"	RDEEL39-74P	<input type="checkbox"/>	<input type="checkbox"/>	<input type="checkbox"/>	<input type="checkbox"/>	<input type="checkbox"/>	<input type="checkbox"/>	<input type="checkbox"/>	30.5#	\$ 445	\$ 56	\$ 19
	Large	26 x 47"	RDEEL47-74P	<input type="checkbox"/>	<input type="checkbox"/>	<input type="checkbox"/>	<input type="checkbox"/>	<input type="checkbox"/>	<input type="checkbox"/>	<input type="checkbox"/>	34.5#	475	56	27
 Sit-Stand Height Adjustable R-Triangle Desk, 29 to 42" H • Casters and glides are interchangeable • Ruckus post-leg desks require assembly • All corners of surface are rounded • Specify casters/glides to wheelbarrow • Legs adjust with screws in 1" increments • Legs are factory pre-set at 29"H • 4 Desks combine to form a square RDEFL	Small	22 x 39"	RDEFL39-74P	<input type="checkbox"/>	<input type="checkbox"/>	<input type="checkbox"/>	<input type="checkbox"/>	<input type="checkbox"/>	<input type="checkbox"/>	<input type="checkbox"/>	33.5#	\$ 477	\$ 65	\$ 19
	Large	26 x 47"	RDEFL47-74P	<input type="checkbox"/>	<input type="checkbox"/>	<input type="checkbox"/>	<input type="checkbox"/>	<input type="checkbox"/>	<input type="checkbox"/>	<input type="checkbox"/>	37.5#	508	65	27

A B C D E F G H

HOW TO ORDER

- Indicate the following information on order form:
- Quantity of each item.
 - Model number, including options. See "How To Build a Model Number".
 - Any special service required.

Note: • The indicates that a choice is required.
 • The absence of the indicates that no choice is required.
 • Alpha-numeric characters in place of indicate that no other alternatives are available.

HOW TO BUILD A MODEL NUMBER

- A** Select basic model/edge style.
74P - 1-1/4" laminate top w/74P edge band
- B** Select edge color.
 Refer to the **Product Color Options** page in this price list.
- C** Select surface finish.
 Refer to the **Product Color Options** page in this price list.
- D** Select base finish.
 Refer to the **Product Color Options** page in this price list.
- E** Select base option.
BCF - Casters/felt glides
BCN - Casters/nylon glides
GFT - Felt glides
GNY - Nylon glides
CCC - Casters

- F** Select under table storage.
NB - No book storage
BBS - Poly book box, small; add \$30
BBL - Poly book box, large; add \$32
BR - Book basket; add \$42
RT - Removable storage tote; add \$47
SBBS - Steel book box, small; add \$68
SBBL - Steel book box, large; add \$78
 BBL & SBBL options are not available on the small desk sizes.
- G** Select book basket color.
 Refer to the **Product Color Options** page in this price list.
 Only if book basket (BR) storage is selected.
- H** Select steel book box color.
 Refer to the **Product Color Options** page in this price list.
 Only if steel book box (SBBS or SBBL) storage is selected.

FINISH INFORMATION

Additional Laminate Offering
 KI offers laminates beyond those offered in the standard offering. Laminates that are currently available in the program can be viewed in KI product specification tools. Requests to add laminates to the program can be submitted via the product modification request process. Please note, requests to add laminates to the program must include the laminate manufacturer's name, color/pattern number, and finish code. Edge options are limited to standard edge colors. If a matching edge is required, this will need to be requested through the product modification request process and may be subject to additional costs. Due to varying manufacturing processes and quality issues with some laminates, some requests may be denied. Extended lead times and minimum order quantities may apply on orders containing special laminates. Contact the product modification team for questions or additional information regarding special laminates and pricing.

SPECIAL SERVICES

Special Carton Marking

With specially marked information N/C

Shipping

Ships **knocked down, FOB Bonduel, WI 54107, freight excluded**. Freight class 70.

Specifications and prices are subject to change without prior notice.

Ruckus® Post-Leg Desk (Freight Excluded Pricing)

1-1/4" Top - 74P Edge



Ruckus® Post-Leg Desk (Freight Excluded Pricing)

1-1/4" Top - 74P Edge

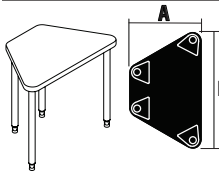
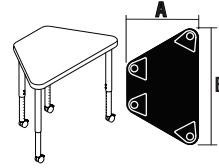
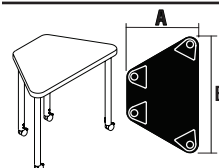
MODEL	Features	A x B	MODEL NUMBER								Approx. Packaged Weight	Freight Excluded Pricing	Chrome Upcharge add to list price	Laminate Grade 2 add to list price	
			Basic Model/Edge Style	Edge Color	Surface Finish	Base Finish	Base Option	Under Table Storage	Book Basket Color	Book Box Color					
 RDEAM Fixed Height Trapezoid Desk, 29" H • Casters and glides are interchangeable • Ruckus post-leg desks require assembly • All corners of surface are rounded • Specify casters/glides to wheelbarrow • 6 Desks combine to form a hexagon	Small	21 x 34"	RDEAM34-74P	<input type="checkbox"/>	<input type="checkbox"/>	<input type="checkbox"/>	<input type="checkbox"/>	<input type="checkbox"/>	<input type="checkbox"/>	<input type="checkbox"/>	<input type="checkbox"/>	35.0#	\$ 451	\$ 68	\$ 19
	Large	24 x 37"	RDEAM37-74P	<input type="checkbox"/>	<input type="checkbox"/>	<input type="checkbox"/>	<input type="checkbox"/>	<input type="checkbox"/>	<input type="checkbox"/>	<input type="checkbox"/>	<input type="checkbox"/>	38.0#	461	68	19
 RDEEM Sit Height Adjustable Trapezoid Desk, 20 to 33" H • Casters and glides are interchangeable • Ruckus post-leg desks require assembly • All corners of surface are rounded • Specify casters/glides to wheelbarrow • Legs adjust with screws in 1" increments • Legs are factory pre-set at 29"H • 6 Desks combine to form a hexagon	Small	21 x 34"	RDEEM34-74P	<input type="checkbox"/>	<input type="checkbox"/>	<input type="checkbox"/>	<input type="checkbox"/>	<input type="checkbox"/>	<input type="checkbox"/>	<input type="checkbox"/>	<input type="checkbox"/>	37.0#	\$ 498	\$ 74	\$ 19
	Large	24 x 37"	RDEEM37-74P	<input type="checkbox"/>	<input type="checkbox"/>	<input type="checkbox"/>	<input type="checkbox"/>	<input type="checkbox"/>	<input type="checkbox"/>	<input type="checkbox"/>	<input type="checkbox"/>	40.0#	508	74	19
 RDEFM Sit-Stand Height Adjustable Trapezoid Desk, 29 to 42" H • Casters and glides are interchangeable • Ruckus post-leg desks require assembly • All corners of surface are rounded • Specify casters/glides to wheelbarrow • Legs adjust with screws in 1" increments • Legs are factory pre-set at 29"H • 6 Desks combine to form a hexagon	Small	21 x 34"	RDEFM34-74P	<input type="checkbox"/>	<input type="checkbox"/>	<input type="checkbox"/>	<input type="checkbox"/>	<input type="checkbox"/>	<input type="checkbox"/>	<input type="checkbox"/>	<input type="checkbox"/>	41.0#	\$ 536	\$ 85	\$ 19
	Large	24 x 37"	RDEFM37-74P	<input type="checkbox"/>	<input type="checkbox"/>	<input type="checkbox"/>	<input type="checkbox"/>	<input type="checkbox"/>	<input type="checkbox"/>	<input type="checkbox"/>	<input type="checkbox"/>	44.0#	547	85	19

A **B** **C** **D** **E** **F** **G** **H**

HOW TO ORDER

- Indicate the following information on order form:
- Quantity of each item.
 - Model number, including options. See "How To Build a Model Number".
 - Any special service required.

Note: • The indicates that a choice is required.
 • The absence of the indicates that no choice is required.
 • Alpha-numeric characters in place of indicate that no other alternatives are available.

HOW TO BUILD A MODEL NUMBER

- A** Select basic model/edge style.
74P - 1-1/4" laminate top w/74P edge band
- B** Select edge color.
 Refer to the **Product Color Options** page in this price list.
- C** Select surface finish.
 Refer to the **Product Color Options** page in this price list.
- D** Select base finish.
 Refer to the **Product Color Options** page in this price list.
- E** Select base option.
BCF - Casters/felt glides
BCN - Casters/nylon glides
GFT - Felt glides
GNY - Nylon glides
CCC - Casters

- F** Select under table storage.
NB - No book storage
BBS - Poly book box, small; add \$30
BBL - Poly book box, large; add \$32
BR - Book basket; add \$42
RT - Removable storage tote; add \$47
SBBS - Steel book box, small; add \$68
SBBL - Steel book box, large; add \$78
 BBL & SBBL options are not available on the small desk sizes.
- G** Select book basket color.
 Refer to the **Product Color Options** page in this price list.
 Only if book basket (BR) storage is selected.
- H** Select steel book box color.
 Refer to the **Product Color Options** page in this price list.
 Only if steel book box (SBBS or SBBL) storage is selected.

FINISH INFORMATION

Additional Laminate Offering

KI offers laminates beyond those offered in the standard offering. Laminates that are currently available in the program can be viewed in KI product specification tools. Requests to add laminates to the program can be submitted via the product modification request process. Please note, requests to add laminates to the program must include the laminate manufacturer's name, color/pattern number, and finish code. Edge options are limited to standard edge colors. If a matching edge is required, this will need to be requested through the product modification request process and may be subject to additional costs. Due to varying manufacturing processes and quality issues with some laminates, some requests may be denied. Extended lead times and minimum order quantities may apply on orders containing special laminates. Contact the product modification team for questions or additional information regarding special laminates and pricing.

SPECIAL SERVICES

Special Carton Marking

With specially marked information N/C

Shipping

Ships **knocked down**, **FOB Bonduel, WI 54107**, **freight excluded**. Freight class 70.

Specifications and prices are subject to change without prior notice.

Ruckus® Post-Leg Desk (Freight Excluded Pricing)

1-1/4" Top - 74P Edge



Ruckus® Post-Leg Desk (Freight Excluded Pricing)

1-1/4" Top - 74P Edge

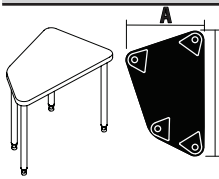
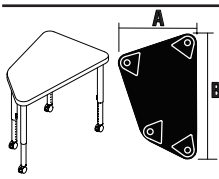
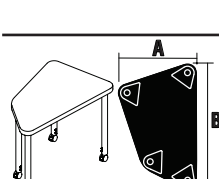
MODEL	Features	A x B	MODEL NUMBER								Approx. Packaged Weight	Freight Excluded Pricing	Chrome Upcharge add to list price	Laminate Grade 2 add to list price
			Basic Model/Edge Style	Edge Color	Surface Finish	Base Finish	Base Option	Under Table Storage	Book Basket Color	Book Box Color				
 RDEAZ Fixed Height Oddquad Desk, 29" H • Casters and glides are interchangeable • Ruckus post-leg desks require assembly • All corners of surface are rounded • Specify casters/glides to wheelbarrow • 4 Desks combine to form a pin-wheel	Small	22 x 36"	RDEAZ36-74P	<input type="checkbox"/>	<input type="checkbox"/>	<input type="checkbox"/>	<input type="checkbox"/>	<input type="checkbox"/>	<input type="checkbox"/>	<input type="checkbox"/>	35.0#	\$ 451	\$ 68	\$ 19
	Large	24 x 39"	RDEAZ39-74P	<input type="checkbox"/>	<input type="checkbox"/>	<input type="checkbox"/>	<input type="checkbox"/>	<input type="checkbox"/>	<input type="checkbox"/>	<input type="checkbox"/>	38.0#	467	68	19
 RDEEZ Sit Height Adjustable Oddquad Desk, 20 to 33" H • Casters and glides are interchangeable • Ruckus post-leg desks require assembly • All corners of surface are rounded • Specify casters/glides to wheelbarrow • Legs adjust with screws in 1" increments • Legs are factory pre-set at 29"H • 4 Desks combine to form a pin-wheel	Small	22 x 36"	RDEEZ36-74P	<input type="checkbox"/>	<input type="checkbox"/>	<input type="checkbox"/>	<input type="checkbox"/>	<input type="checkbox"/>	<input type="checkbox"/>	<input type="checkbox"/>	37.0#	\$ 498	\$ 74	\$ 19
	Large	24 x 39"	RDEEZ39-74P	<input type="checkbox"/>	<input type="checkbox"/>	<input type="checkbox"/>	<input type="checkbox"/>	<input type="checkbox"/>	<input type="checkbox"/>	<input type="checkbox"/>	40.0#	513	74	19
 RDEFZ 29 to 42" Sit-Stand Height Adjustable Oddquad Desk • Casters and glides are interchangeable • Ruckus post-leg desks require assembly • All corners of surface are rounded • Specify casters/glides to wheelbarrow • Legs adjust with screws in 1" increments • Legs are factory pre-set at 29"H • 4 Desks combine to form a pin-wheel	Small	22 x 36"	RDEFZ36-74P	<input type="checkbox"/>	<input type="checkbox"/>	<input type="checkbox"/>	<input type="checkbox"/>	<input type="checkbox"/>	<input type="checkbox"/>	<input type="checkbox"/>	41.0#	\$ 536	\$ 85	\$ 19
	Large	24 x 39"	RDEFZ39-74P	<input type="checkbox"/>	<input type="checkbox"/>	<input type="checkbox"/>	<input type="checkbox"/>	<input type="checkbox"/>	<input type="checkbox"/>	<input type="checkbox"/>	44.0#	553	85	19

A B C D E F G H

HOW TO ORDER

- Indicate the following information on order form:
- Quantity of each item.
 - Model number, including options. See "How To Build a Model Number".
 - Any special service required.

Note: • The indicates that a choice is required.

- The absence of the indicates that no choice is required.
- Alpha-numeric characters in place of indicate that no other alternatives are available.

HOW TO BUILD A MODEL NUMBER

A Select basic model/edge style.
74P - 1-1/4" laminate top w/74P edge band

B Select edge color.
 Refer to the **Product Color Options** page in this price list.

C Select surface finish.
 Refer to the **Product Color Options** page in this price list.

D Select base finish.
 Refer to the **Product Color Options** page in this price list.

E Select base option.
BCF - Casters/felt glides
BCN - Casters/nylon glides
GFT - Felt glides
GNV - Nylon glides
CCC - Casters

F Select under table storage.
NB - No book storage
BBS - Poly book box, small; add \$30
BBL - Poly book box, large; add \$32
BR - Book basket; add \$42
RT - Removable storage tote; add \$47
SBBS - Steel book box, small; add \$68
SBBL - Steel book box, large; add \$78
 BBL & SBBL options are not available on the small desk sizes.

G Select book basket color.
 Refer to the **Product Color Options** page in this price list.
 Only if book basket (BR) storage is selected.

H Select steel book box color.
 Refer to the **Product Color Options** page in this price list.
 Only if steel book box (SBBS or SBBL) storage is selected.

FINISH INFORMATION

Additional Laminate Offering

KI offers laminates beyond those offered in the standard offering. Laminates that are currently available in the program can be viewed in KI product specification tools. Requests to add laminates to the program can be submitted via the product modification request process. Please note, requests to add laminates to the program must include the laminate manufacturer's name, color/pattern number, and finish code. Edge options are limited to standard edge colors. If a matching edge is required, this will need to be requested through the product modification request process and may be subject to additional costs. Due to varying manufacturing processes and quality issues with some laminates, some requests may be denied. Extended lead times and minimum order quantities may apply on orders containing special laminates. Contact the product modification team for questions or additional information regarding special laminates and pricing.

SPECIAL SERVICES

Special Carton Marking

With specially marked information N/C

Shipping
 Ships **knocked down, FOB Bonduel, WI 54107, freight excluded.** Freight class 70.

Specifications and prices are subject to change without prior notice.

Ruckus® Post-Leg Desk (Freight Excluded Pricing)

1-1/4" Top - 74P Edge



Ruckus® Post-Leg Desk (Freight Excluded Pricing)

1-1/4" Top - 74P Edge

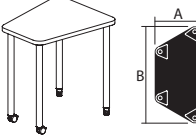
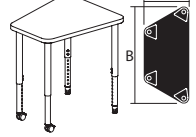
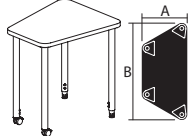
MODEL	A x B	MODEL NUMBER								Approx. Packaged Weight	Freight Excluded Pricing	Chrome Upcharge add to list price	Laminate Grade 2 add to list price
		Basic Model/Edge Style	Edge Color	Surface Finish	Base Finish	Base Option	Under Table Storage	Book Basket Color	Book Box Color				
 <p>Fixed Height Pentaquad Desk, 29" H</p> <ul style="list-style-type: none"> • Casters and glides are interchangeable • Ruckus post leg desks require assembly • All corners of surface are rounded • Specify casters/glides to wheelbarrow • Configures into pods of four or five desks 	26 x 30"	RDEAS2630-74P	<input type="checkbox"/>	<input type="checkbox"/>	<input type="checkbox"/>	<input type="checkbox"/>	<input type="checkbox"/>	<input type="checkbox"/>	<input type="checkbox"/>	58.00#	\$ 457	\$ 68	\$ 27
RDEAS													
 <p>Sit Height Adjustable Pentaquad Desk, 20 to 33" H</p> <ul style="list-style-type: none"> • Casters and glides are interchangeable • Ruckus post leg desks require assembly • All corners of surface are rounded • Specify casters/glides to wheelbarrow • Configures into pods of four or five desks 	26 x 30"	RDEES2630-74P	<input type="checkbox"/>	<input type="checkbox"/>	<input type="checkbox"/>	<input type="checkbox"/>	<input type="checkbox"/>	<input type="checkbox"/>	<input type="checkbox"/>	60.00#	\$ 513	\$ 74	\$ 27
RDEES													
 <p>29 to 42" Sit-Stand Height Adjustable Pentaquad Desk</p> <ul style="list-style-type: none"> • Casters and glides are interchangeable • Ruckus post leg desks require assembly • All corners of surface are rounded • Specify casters/glides to wheelbarrow • Legs adjust with screws in 1" increments • Legs are factory pre-set at 29"H • Configures into pods of four or five desks 	26 x 30"	RDEFS2630-74P	<input type="checkbox"/>	<input type="checkbox"/>	<input type="checkbox"/>	<input type="checkbox"/>	<input type="checkbox"/>	<input type="checkbox"/>	<input type="checkbox"/>	64.00#	\$ 548	\$ 85	\$ 27
RDEFS													

A B C D E F G H

HOW TO ORDER

- Indicate the following information on order form:
1. Quantity of each item.
 2. Model number, including options. See "How To Build a Model Number".
 3. Any special service required.

Note: • The indicates that a choice is required.
 • The absence of the indicates that no choice is required.
 • Alpha-numeric characters in place of indicate that no other alternatives are available.

HOW TO BUILD A MODEL NUMBER

- A** Select basic model/edge style.
74P - 1-1/4" laminate top w/74P edge band
- B** Select edge color.
 Refer to the **Product Color Options** page in this price list.
- C** Select surface finish.
 Refer to the **Product Color Options** page in this price list.
- D** Select base finish.
 Refer to the **Product Color Options** page in this price list.
- E** Select base option.
BCF - Casters/felt glides
BCN - Casters/nylon glides
GFT - Felt glides
GNY - Nylon glides
CCC - Casters

- F** Select under table storage.
NB - No book storage
BBS - Poly book box, small; add \$30
BBL - Poly book box, large; add \$32
BR - Book basket; add \$42
RT - Removable storage tote; add \$47
SBBS - Steel book box, small; add \$68
SBBL - Steel book box, large; add \$78
 BBL & SBBL options are not available on the small desk sizes.
- G** Select book basket color.
 Refer to the **Product Color Options** page in this price list.
 Only if book basket (BR) storage is selected.
- H** Select steel book box color.
 Refer to the **Product Color Options** page in this price list.
 Only if steel book box (SBBS or SBBL) storage is selected.

FINISH INFORMATION

Additional Laminate Offering

KI offers laminates beyond those offered in the standard offering. Laminates that are currently available in the program can be viewed in KI product specification tools. Requests to add laminates to the program can be submitted via the product modification request process. Please note, requests to add laminates to the program must include the laminate manufacturer's name, color/pattern number, and finish code. Edge options are limited to standard edge colors. If a matching edge is required, this will need to be requested through the product modification request process and may be subject to additional costs. Due to varying manufacturing processes and quality issues with some laminates, some requests may be denied. Extended lead times and minimum order quantities may apply on orders containing special laminates. Contact the product modification team for questions or additional information regarding special laminates and pricing.

SPECIAL SERVICES

Special Carton Marking

With specially marked information N/C

Shipping
 Ships **knocked down**, FOB **Bonduel, WI 54107**, **freight excluded**. Freight class 70.

Specifications and prices are subject to change without prior notice.



MODEL	MODEL NUMBER	Approx. Packaged Weight	Freight Excluded Pricing
	Basic Model		
 <p>Book Bag Hook</p> <ul style="list-style-type: none"> • 1/4" solid wire rod • Chrome finish • Field installable • Includes 2 screws 	RKUSBBH1	3.0#	\$ 10

RKAU

A

HOW TO ORDER

- Indicate the following information on order form:
1. Quantity of each item.
 2. Model number, including options. See "How To Build a Model Number".
 3. Any special service required.

- Note:
- The indicates that a choice is required.
 - The absence of the indicates that no choice is required.
 - Alpha-numeric characters in place of indicate that no other alternatives are available.

HOW TO BUILD A MODEL NUMBER

- A** Select basic model.

SPECIAL SERVICES

Special Carton Marking

With specially marked information N/C

Shipping

Ships **knocked down, FOB Bonduel, WI 54107, freight excluded.** Freight class 85.

Specifications and prices are subject to change without prior notice.

Ruckus® Activity Table (Freight Excluded Pricing)

3/4" Top - 73P Edge



Ruckus® Activity Table (Freight Excluded Pricing)

3/4" Top - 73P Edge

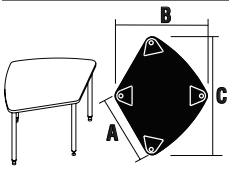
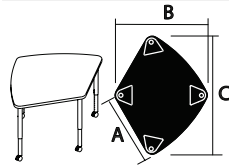
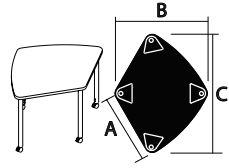
MODEL	A x B x C	MODEL NUMBER					Approx. Packaged Weight	Freight Excluded Pricing	Chrome Upcharge add to list price	Laminate Grade 2 add to list price
		Basic Model/ Edge Style	Edge Color	Surface Finish	Base Finish	Base Option				
 <p>Fixed Height Diamond Table, 28-1/2" H</p> <ul style="list-style-type: none"> • Casters and glides are interchangeable • Tables are designed for maximum leg spacing • All corners of surface are rounded • Specify casters/glides to wheelbarrow • 3 tables combine to form a guitar pick 	30 x 39 x 50"	RTEAE30-73P	<input type="checkbox"/>	<input type="checkbox"/>	<input type="checkbox"/>	48.00#	\$ 661	\$ 70	\$ 53	
	36 x 47 x 60"	RTEAE36-73P	<input type="checkbox"/>	<input type="checkbox"/>	<input type="checkbox"/>	59.00#	700	70	53	
RTEAE										
 <p>Sit Height Adjustable Diamond Table, 19-1/2 to 32-1/2" H</p> <ul style="list-style-type: none"> • Casters and glides are interchangeable • Tables are designed for maximum leg spacing • All corners of surface are rounded • Specify casters/glides to wheelbarrow • Legs adjust with screws in 1" increments • Legs are factory pre-set at 28-1/2"H • 3 tables combine to form a guitar pick 	30 x 39 x 50"	RTEEE30-73P	<input type="checkbox"/>	<input type="checkbox"/>	<input type="checkbox"/>	50.00#	\$ 713	\$ 77	\$ 53	
	36 x 47 x 60"	RTEEE36-73P	<input type="checkbox"/>	<input type="checkbox"/>	<input type="checkbox"/>	61.00#	752	77	53	
RTEEE										
 <p>Sit-Stand Height Adjustable Diamond Table, 28-1/2 to 41-1/2" H</p> <ul style="list-style-type: none"> • Casters and glides are interchangeable • Tables are designed for maximum leg spacing • All corners of surface are rounded • Specify casters/glides to wheelbarrow • Legs adjust with screws in 1" increments • Legs are factory pre-set at 28-1/2"H • 3 tables combine to form a guitar pick 	30 x 39 x 50"	RTEFE30-73P	<input type="checkbox"/>	<input type="checkbox"/>	<input type="checkbox"/>	54.00#	\$ 750	\$ 88	\$ 53	
	36 x 47 x 60"	RTEFE36-73P	<input type="checkbox"/>	<input type="checkbox"/>	<input type="checkbox"/>	65.00#	791	88	53	
RTEFE										

A B C D E

HOW TO ORDER

- Indicate the following information on order form:
1. Quantity of each item.
 2. Model number, including options. See "How To Build a Model Number".
 3. Any special service required.

Note: • The indicates that a choice is required.
 • The absence of the indicates that no choice is required.
 • Alpha-numeric characters in place of indicate that no other alternatives are available.

HOW TO BUILD A MODEL NUMBER

- A** Select basic model/edge style.
73P - 3/4" laminate top w/73P edge band
- B** Select edge color.
 Refer to the **Product Color Options** page in this price list.
- C** Select surface finish.
 Refer to the **Product Color Options** page in this price list.
- D** Select base finish.
 Refer to the **Product Color Options** page in this price list.
- E** Select base option.

CCC	- Casters
BCF	- Casters/felt glides
BCN	- Casters/nylon glides
GFT	- Felt glides
GNV	- Nylon glides

FINISH INFORMATION

Additional Laminate Offering

KI offers laminates beyond those offered in the standard offering. Laminates that are currently available in the program can be viewed in KI product specification tools. Requests to add laminates to the program can be submitted via the product modification request process. Please note, requests to add laminates to the program must include the laminate manufacturer's name, color/pattern number, and finish code. Edge options are limited to standard edge colors. If a matching edge is required, this will need to be requested through the product modification request process and may be subject to additional costs. Due to varying manufacturing processes and quality issues with some laminates, some requests may be denied. Extended lead times and minimum order quantities may apply on orders containing special laminates. Contact the product modification team for questions or additional information regarding special laminates and pricing.

SPECIAL SERVICES

Special Carton Marking

With specially marked information N/C

Shipping

Ships **knocked down, FOB Bonduel, WI 54107, freight excluded.** Freight class 70.

Specifications and prices are subject to change without prior notice.

Ruckus® Activity Table (Freight Excluded Pricing)

3/4" Top - 73P Edge



Ruckus® Activity Table (Freight Excluded Pricing)

3/4" Top - 73P Edge

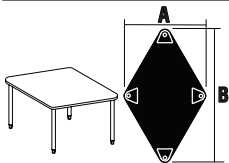
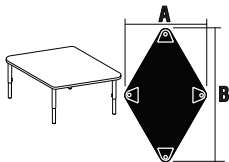
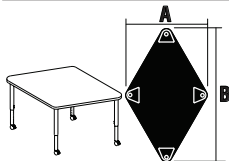
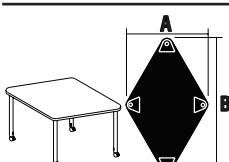
MODEL	Features	A x B	MODEL NUMBER					Approx. Packaged Weight	Freight Excluded Pricing	Chrome Upcharge add to list price	Laminate Grade 2 add to list price
			Basic Model/Edge Style	Edge Color	Surface Finish	Base Finish	Base Option				
 <p>Fixed Height Kite Table, 28-1/2" H</p> <ul style="list-style-type: none"> • Casters and glides are interchangeable • Tables are designed for maximum leg spacing • All corners of surface are rounded • Specify casters/glides to wheelbarrow • 3 Tables combine to form a hexagon 	Small	35 x 57"	RTEAJ34-73P	<input type="checkbox"/> <input type="checkbox"/> <input type="checkbox"/>	<input type="checkbox"/> <input type="checkbox"/> <input type="checkbox"/>	<input type="checkbox"/> <input type="checkbox"/>	<input type="checkbox"/> <input type="checkbox"/> <input type="checkbox"/>	47.00#	\$ 647	\$ 70	\$ 53
	Large	40 x 66"	RTEAJ39-73P	<input type="checkbox"/> <input type="checkbox"/> <input type="checkbox"/>	<input type="checkbox"/> <input type="checkbox"/> <input type="checkbox"/>	<input type="checkbox"/> <input type="checkbox"/>	<input type="checkbox"/> <input type="checkbox"/> <input type="checkbox"/>	55.00#	737	70	53
RTEAJ											
 <p>Floor Height Adjustable Kite Table, 11-1/2 to 18-1/2" H</p> <ul style="list-style-type: none"> • Tables are designed for maximum leg spacing • All corners of surface are rounded • Legs adjust with screws in 1" increments • Legs are factory pre-set at 18-1/2" H • 3 Tables combine to form a hexagon • Base only available in glides 	Small	35 x 57"	RTEHJ34-73P	<input type="checkbox"/> <input type="checkbox"/> <input type="checkbox"/>	<input type="checkbox"/> <input type="checkbox"/> <input type="checkbox"/>	<input type="checkbox"/> <input type="checkbox"/>	<input type="checkbox"/> <input type="checkbox"/> <input type="checkbox"/>	44.50#	\$ 647	\$ 75	\$ 53
	Large	40 x 66"	RTEHJ39-73P	<input type="checkbox"/> <input type="checkbox"/> <input type="checkbox"/>	<input type="checkbox"/> <input type="checkbox"/> <input type="checkbox"/>	<input type="checkbox"/> <input type="checkbox"/>	<input type="checkbox"/> <input type="checkbox"/> <input type="checkbox"/>	52.50#	731	75	53
RTEHJ											
 <p>Sit Height Adjustable Kite Table, 19-1/2 to 32-1/2" H</p> <ul style="list-style-type: none"> • Casters and glides are interchangeable • Tables are designed for maximum leg spacing • All corners of surface are rounded • Specify casters/glides to wheelbarrow • Legs adjust with screws in 1" increments • Legs are factory pre-set at 28-1/2" H • 3 Tables combine to form a hexagon 	Small	35 x 57"	RTEEJ34-73P	<input type="checkbox"/> <input type="checkbox"/> <input type="checkbox"/>	<input type="checkbox"/> <input type="checkbox"/> <input type="checkbox"/>	<input type="checkbox"/> <input type="checkbox"/>	<input type="checkbox"/> <input type="checkbox"/> <input type="checkbox"/>	49.00#	\$ 688	\$ 77	\$ 53
	Large	40 x 66"	RTEEJ39-73P	<input type="checkbox"/> <input type="checkbox"/> <input type="checkbox"/>	<input type="checkbox"/> <input type="checkbox"/> <input type="checkbox"/>	<input type="checkbox"/> <input type="checkbox"/>	<input type="checkbox"/> <input type="checkbox"/> <input type="checkbox"/>	57.00#	777	77	53
RTEEJ											
 <p>Sit-Stand Height Adjustable Kite Table, 28-1/2 to 41-1/2" H</p> <ul style="list-style-type: none"> • Casters and glides are interchangeable • Tables are designed for maximum leg spacing • All corners of surface are rounded • Specify casters/glides to wheelbarrow • Legs adjust with screws in 1" increments • Legs are factory pre-set at 28-1/2" H • 3 Tables combine to form a hexagon 	Small	35 x 57"	RTEFJ34-73P	<input type="checkbox"/> <input type="checkbox"/> <input type="checkbox"/>	<input type="checkbox"/> <input type="checkbox"/> <input type="checkbox"/>	<input type="checkbox"/> <input type="checkbox"/>	<input type="checkbox"/> <input type="checkbox"/> <input type="checkbox"/>	53.00#	\$ 735	\$ 88	\$ 53
	Large	40 x 66"	RTEFJ39-73P	<input type="checkbox"/> <input type="checkbox"/> <input type="checkbox"/>	<input type="checkbox"/> <input type="checkbox"/> <input type="checkbox"/>	<input type="checkbox"/> <input type="checkbox"/>	<input type="checkbox"/> <input type="checkbox"/> <input type="checkbox"/>	61.00#	825	88	53
RTEFJ											

A **B** **C** **D** **E**

HOW TO ORDER

- Indicate the following information on order form:
1. Quantity of each item.
 2. Model number, including options. See "How To Build a Model Number".
 3. Any special service required.

Note: • The indicates that a choice is required.

- The absence of the indicates that no choice is required.
- Alpha-numeric characters in place of indicate that no other alternatives are available.

HOW TO BUILD A MODEL NUMBER

A Select basic model/edge style.
73P - 3/4" laminate top w/73P edge band

B Select edge color.
 Refer to the **Product Color Options** page in this price list.

C Select surface finish.
 Refer to the **Product Color Options** page in this price list.

D Select base finish.
 Refer to the **Product Color Options** page in this price list.

E Select base option.
CCC - Casters
BCF - Casters/felt glides
BCN - Casters/nylon glides
GFT - Felt glides
GNV - Nylon glides
 Base options for Floor Height Adjustable are

ONLY Felt glides - GFT and Nylon glides - GNV

FINISH INFORMATION

Additional Laminate Offering

KI offers laminates beyond those offered in the standard offering. Laminates that are currently available in the program can be viewed in KI product specification tools. Requests to add laminates to the program can be submitted via the product modification request process. Please note, requests to add laminates to the program must include the laminate manufacturer's name, color/pattern number, and finish code. Edge options are limited to standard edge colors. If a matching edge is required, this will need to be requested through the product modification request process and may be subject to additional costs. Due to varying manufacturing processes and quality issues with some laminates, some requests may be denied. Extended lead times and minimum order quantities may apply on orders containing special laminates. Contact the product modification team for questions or additional information regarding special laminates and pricing.

SPECIAL SERVICES

Special Carton Marking

With specially marked information N/C

Shipping
 Ships **knocked down, FOB Bonduel, WI 54107, freight excluded.** Freight class 70.

Specifications and prices are subject to change without prior notice.

Ruckus® Activity Table (Freight Excluded Pricing)

1-1/4" Top - 74P Edge



Ruckus® Activity Table (Freight Excluded Pricing)

1-1/4" Top - 74P Edge

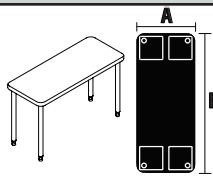
MODEL	A x B	MODEL NUMBER					Approx. Packaged Weight	Freight Excluded Pricing	Chrome Upcharge add to list price	Laminate Grade 2 add to list price
		Basic Model/Edge Style	Edge Color	Surface Finish	Base Finish	Base Option				
 <p>Fixed Height Rectangular Rounded Corners Table, 29" H</p> <ul style="list-style-type: none"> • Casters and glides are interchangeable • Tables are designed for maximum leg spacing • All corners of surface are rounded • Specify casters/glides to wheelbarrow • 42x72, 44x72 and 48x72 have a center leg 	20 x 48"	RTEAA2048	<input type="checkbox"/>	<input type="checkbox"/>	<input type="checkbox"/>	<input type="checkbox"/>	67.30#	\$ 557	\$ 70	\$ 19
	20 x 54"	RTEAA2054	<input type="checkbox"/>	<input type="checkbox"/>	<input type="checkbox"/>	<input type="checkbox"/>	71.50#	576	70	19
	20 x 60"	RTEAA2060	<input type="checkbox"/>	<input type="checkbox"/>	<input type="checkbox"/>	<input type="checkbox"/>	75.70#	577	70	19
	20 x 66"	RTEAA2066	<input type="checkbox"/>	<input type="checkbox"/>	<input type="checkbox"/>	<input type="checkbox"/>	81.00#	555	70	19
	20 x 72"	RTEAA2072	<input type="checkbox"/>	<input type="checkbox"/>	<input type="checkbox"/>	<input type="checkbox"/>	84.00#	596	70	19
	24 x 30"	RTEAA2430	<input type="checkbox"/>	<input type="checkbox"/>	<input type="checkbox"/>	<input type="checkbox"/>	59.00#	528	70	19
	24 x 36"	RTEAA2436	<input type="checkbox"/>	<input type="checkbox"/>	<input type="checkbox"/>	<input type="checkbox"/>	64.00#	541	70	19
	24 x 48"	RTEAA2448	<input type="checkbox"/>	<input type="checkbox"/>	<input type="checkbox"/>	<input type="checkbox"/>	74.00#	557	70	19
	24 x 54"	RTEAA2454	<input type="checkbox"/>	<input type="checkbox"/>	<input type="checkbox"/>	<input type="checkbox"/>	79.00#	576	70	27
	24 x 60"	RTEAA2460	<input type="checkbox"/>	<input type="checkbox"/>	<input type="checkbox"/>	<input type="checkbox"/>	84.00#	577	70	27
	24 x 66"	RTEAA2466	<input type="checkbox"/>	<input type="checkbox"/>	<input type="checkbox"/>	<input type="checkbox"/>	90.00#	558	70	27
	24 x 72"	RTEAA2472	<input type="checkbox"/>	<input type="checkbox"/>	<input type="checkbox"/>	<input type="checkbox"/>	94.00#	596	70	27
	30 x 48"	RTEAA3048	<input type="checkbox"/>	<input type="checkbox"/>	<input type="checkbox"/>	<input type="checkbox"/>	84.00#	587	70	27
	30 x 54"	RTEAA3054	<input type="checkbox"/>	<input type="checkbox"/>	<input type="checkbox"/>	<input type="checkbox"/>	90.30#	610	70	27
	30 x 60"	RTEAA3060	<input type="checkbox"/>	<input type="checkbox"/>	<input type="checkbox"/>	<input type="checkbox"/>	96.50#	611	70	27
	30 x 66"	RTEAA3066	<input type="checkbox"/>	<input type="checkbox"/>	<input type="checkbox"/>	<input type="checkbox"/>	104.00#	580	70	27
	30 x 72"	RTEAA3072	<input type="checkbox"/>	<input type="checkbox"/>	<input type="checkbox"/>	<input type="checkbox"/>	109.00#	618	70	27
	36 x 54"	RTEAA3654	<input type="checkbox"/>	<input type="checkbox"/>	<input type="checkbox"/>	<input type="checkbox"/>	101.50#	763	70	53
	36 x 60"	RTEAA3660	<input type="checkbox"/>	<input type="checkbox"/>	<input type="checkbox"/>	<input type="checkbox"/>	109.00#	768	70	53
	36 x 66"	RTEAA3666	<input type="checkbox"/>	<input type="checkbox"/>	<input type="checkbox"/>	<input type="checkbox"/>	116.00#	724	70	53
	36 x 72"	RTEAA3672	<input type="checkbox"/>	<input type="checkbox"/>	<input type="checkbox"/>	<input type="checkbox"/>	124.00#	786	70	53
	42 x 60"	RTEAA4260	<input type="checkbox"/>	<input type="checkbox"/>	<input type="checkbox"/>	<input type="checkbox"/>	121.50#	767	70	53
	42 x 66"	RTEAA4266	<input type="checkbox"/>	<input type="checkbox"/>	<input type="checkbox"/>	<input type="checkbox"/>	128.00#	725	70	53
	42 x 72"	RTEAA4272	<input type="checkbox"/>	<input type="checkbox"/>	<input type="checkbox"/>	<input type="checkbox"/>	139.00#	767	70	53
	44 x 60"	RTEAA4460	<input type="checkbox"/>	<input type="checkbox"/>	<input type="checkbox"/>	<input type="checkbox"/>	125.70#	891	70	53
	44 x 66"	RTEAA4466	<input type="checkbox"/>	<input type="checkbox"/>	<input type="checkbox"/>	<input type="checkbox"/>	138.00#	843	70	53
	44 x 72"	RTEAA4472	<input type="checkbox"/>	<input type="checkbox"/>	<input type="checkbox"/>	<input type="checkbox"/>	144.00#	891	70	53
	48 x 60"	RTEAA4860	<input type="checkbox"/>	<input type="checkbox"/>	<input type="checkbox"/>	<input type="checkbox"/>	136.00#	890	70	53
48 x 66"	RTEAA4866	<input type="checkbox"/>	<input type="checkbox"/>	<input type="checkbox"/>	<input type="checkbox"/>	148.00#	892	70	53	
48 x 72"	RTEAA4872	<input type="checkbox"/>	<input type="checkbox"/>	<input type="checkbox"/>	<input type="checkbox"/>	149.00#	894	70	53	

A **B** **C** **D** **E**

HOW TO ORDER

- Indicate the following information on order form:
1. Quantity of each item.
 2. Model number, including options. See "How To Build a Model Number".
 3. Any special service required.

Note: • The indicates that a choice is required.

- The absence of the indicates that no choice is required.
- Alpha-numeric characters in place of indicate that no other alternatives are available.

HOW TO BUILD A MODEL NUMBER

- A** Select basic model/edge style.
74P - 1-1/4" laminate top w/74P edge band
- B** Select edge color.
Refer to the **Product Color Options** page in this price list.
- C** Select surface finish.
Refer to the **Product Color Options** page in this price list.
- D** Select base finish.
Refer to the **Product Color Options** page in this price list.
- E** Select base option.
CCC - Casters
BCF - Casters/felt glides
BCN - Casters/nylon glides
GFT - Felt glides
GNV - Nylon glides

FINISH INFORMATION

Additional Laminate Offering

KI offers laminates beyond those offered in the standard offering. Laminates that are currently available in the program can be viewed in KI product specification tools. Requests to add laminates to the program can be submitted via the product modification request process. Please note, requests to add laminates to the program must include the laminate manufacturer's name, color/pattern number, and finish code. Edge options are limited to standard edge colors. If a matching edge is required, this will need to be requested through the product modification request process and may be subject to additional costs. Due to varying manufacturing processes and quality issues with some laminates, some requests may be denied. Extended lead times and minimum order quantities may apply on orders containing special laminates. Contact the product modification team for questions or additional information regarding special laminates and pricing.

SPECIAL SERVICES

Special Carton Marking

With specially marked information N/C

Shipping

Ships **knocked down, FOB Bonduel, WI 54107, freight excluded.** Freight class 70.

Specifications and prices are subject to change without prior notice.

Ruckus® Activity Table (Freight Excluded Pricing)

1-1/4" Top - 74P Edge



Ruckus® Activity Table (Freight Excluded Pricing)

1-1/4" Top - 74P Edge

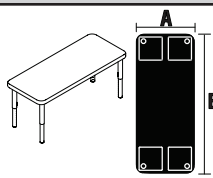
MODEL	A x B	MODEL NUMBER					Approx. Packaged Weight	Freight Excluded Pricing	Chrome Upcharge add to list price	Laminate Grade 2 add to list price
		Basic Model/Edge Style	Edge Color	Surface Finish	Base Finish	Base Option				
 <p>RTEHA</p> <p>Floor Height Adjustable Rectangle Rounded Corners Table, 12 to 19" H</p> <ul style="list-style-type: none"> • Tables are designed for maximum leg spacing • All corners of surface are rounded • Legs adjust with screws in 1" increments • Legs are factory pre-set at 19"H • Base only available in glides 	20 x 48"	RTEHA2048	<input type="checkbox"/> <input type="checkbox"/> <input type="checkbox"/>	<input type="checkbox"/> <input type="checkbox"/> <input type="checkbox"/>	<input type="checkbox"/> <input type="checkbox"/>	<input type="checkbox"/> <input type="checkbox"/> <input type="checkbox"/>	64.80#	\$ 570	\$ 75	\$ 19
	20 x 54"	RTEHA2054	<input type="checkbox"/> <input type="checkbox"/> <input type="checkbox"/>	<input type="checkbox"/> <input type="checkbox"/> <input type="checkbox"/>	<input type="checkbox"/> <input type="checkbox"/>	<input type="checkbox"/> <input type="checkbox"/> <input type="checkbox"/>	79.00#	583	75	19
	20 x 60"	RTEHA2060	<input type="checkbox"/> <input type="checkbox"/> <input type="checkbox"/>	<input type="checkbox"/> <input type="checkbox"/> <input type="checkbox"/>	<input type="checkbox"/> <input type="checkbox"/>	<input type="checkbox"/> <input type="checkbox"/> <input type="checkbox"/>	73.20#	586	75	19
	20 x 66"	RTEHA2066	<input type="checkbox"/> <input type="checkbox"/> <input type="checkbox"/>	<input type="checkbox"/> <input type="checkbox"/> <input type="checkbox"/>	<input type="checkbox"/> <input type="checkbox"/>	<input type="checkbox"/> <input type="checkbox"/> <input type="checkbox"/>	78.50#	596	75	19
	20 x 72"	RTEHA2072	<input type="checkbox"/> <input type="checkbox"/> <input type="checkbox"/>	<input type="checkbox"/> <input type="checkbox"/> <input type="checkbox"/>	<input type="checkbox"/> <input type="checkbox"/>	<input type="checkbox"/> <input type="checkbox"/> <input type="checkbox"/>	81.50#	603	75	19
	24 x 36"	RTEHA2436	<input type="checkbox"/> <input type="checkbox"/> <input type="checkbox"/>	<input type="checkbox"/> <input type="checkbox"/> <input type="checkbox"/>	<input type="checkbox"/> <input type="checkbox"/>	<input type="checkbox"/> <input type="checkbox"/> <input type="checkbox"/>	61.50#	555	75	19
	24 x 42"	RTEHA2442	<input type="checkbox"/> <input type="checkbox"/> <input type="checkbox"/>	<input type="checkbox"/> <input type="checkbox"/> <input type="checkbox"/>	<input type="checkbox"/> <input type="checkbox"/>	<input type="checkbox"/> <input type="checkbox"/> <input type="checkbox"/>	66.50#	567	75	19
	24 x 48"	RTEHA2448	<input type="checkbox"/> <input type="checkbox"/> <input type="checkbox"/>	<input type="checkbox"/> <input type="checkbox"/> <input type="checkbox"/>	<input type="checkbox"/> <input type="checkbox"/>	<input type="checkbox"/> <input type="checkbox"/> <input type="checkbox"/>	71.50#	572	75	19
	24 x 54"	RTEHA2454	<input type="checkbox"/> <input type="checkbox"/> <input type="checkbox"/>	<input type="checkbox"/> <input type="checkbox"/> <input type="checkbox"/>	<input type="checkbox"/> <input type="checkbox"/>	<input type="checkbox"/> <input type="checkbox"/> <input type="checkbox"/>	76.50#	584	75	27
	24 x 60"	RTEHA2460	<input type="checkbox"/> <input type="checkbox"/> <input type="checkbox"/>	<input type="checkbox"/> <input type="checkbox"/> <input type="checkbox"/>	<input type="checkbox"/> <input type="checkbox"/>	<input type="checkbox"/> <input type="checkbox"/> <input type="checkbox"/>	81.50#	587	75	27
	24 x 66"	RTEHA2466	<input type="checkbox"/> <input type="checkbox"/> <input type="checkbox"/>	<input type="checkbox"/> <input type="checkbox"/> <input type="checkbox"/>	<input type="checkbox"/> <input type="checkbox"/>	<input type="checkbox"/> <input type="checkbox"/> <input type="checkbox"/>	87.50#	600	75	27
	24 x 72"	RTEHA2472	<input type="checkbox"/> <input type="checkbox"/> <input type="checkbox"/>	<input type="checkbox"/> <input type="checkbox"/> <input type="checkbox"/>	<input type="checkbox"/> <input type="checkbox"/>	<input type="checkbox"/> <input type="checkbox"/> <input type="checkbox"/>	91.50#	604	75	27
	30 x 42"	RTEHA3042	<input type="checkbox"/> <input type="checkbox"/> <input type="checkbox"/>	<input type="checkbox"/> <input type="checkbox"/> <input type="checkbox"/>	<input type="checkbox"/> <input type="checkbox"/>	<input type="checkbox"/> <input type="checkbox"/> <input type="checkbox"/>	78.50#	600	75	27
	30 x 48"	RTEHA3048	<input type="checkbox"/> <input type="checkbox"/> <input type="checkbox"/>	<input type="checkbox"/> <input type="checkbox"/> <input type="checkbox"/>	<input type="checkbox"/> <input type="checkbox"/>	<input type="checkbox"/> <input type="checkbox"/> <input type="checkbox"/>	81.50#	606	75	27
	30 x 54"	RTEHA3054	<input type="checkbox"/> <input type="checkbox"/> <input type="checkbox"/>	<input type="checkbox"/> <input type="checkbox"/> <input type="checkbox"/>	<input type="checkbox"/> <input type="checkbox"/>	<input type="checkbox"/> <input type="checkbox"/> <input type="checkbox"/>	87.80#	613	75	27
	30 x 60"	RTEHA3060	<input type="checkbox"/> <input type="checkbox"/> <input type="checkbox"/>	<input type="checkbox"/> <input type="checkbox"/> <input type="checkbox"/>	<input type="checkbox"/> <input type="checkbox"/>	<input type="checkbox"/> <input type="checkbox"/> <input type="checkbox"/>	94.00#	616	75	27
	30 x 66"	RTEHA3066	<input type="checkbox"/> <input type="checkbox"/> <input type="checkbox"/>	<input type="checkbox"/> <input type="checkbox"/> <input type="checkbox"/>	<input type="checkbox"/> <input type="checkbox"/>	<input type="checkbox"/> <input type="checkbox"/> <input type="checkbox"/>	102.50#	619	75	27
	30 x 72"	RTEHA3072	<input type="checkbox"/> <input type="checkbox"/> <input type="checkbox"/>	<input type="checkbox"/> <input type="checkbox"/> <input type="checkbox"/>	<input type="checkbox"/> <input type="checkbox"/>	<input type="checkbox"/> <input type="checkbox"/> <input type="checkbox"/>	106.50#	623	75	27
	36 x 54"	RTEHA3654	<input type="checkbox"/> <input type="checkbox"/> <input type="checkbox"/>	<input type="checkbox"/> <input type="checkbox"/> <input type="checkbox"/>	<input type="checkbox"/> <input type="checkbox"/>	<input type="checkbox"/> <input type="checkbox"/> <input type="checkbox"/>	99.00#	754	75	53
	36 x 60"	RTEHA3660	<input type="checkbox"/> <input type="checkbox"/> <input type="checkbox"/>	<input type="checkbox"/> <input type="checkbox"/> <input type="checkbox"/>	<input type="checkbox"/> <input type="checkbox"/>	<input type="checkbox"/> <input type="checkbox"/> <input type="checkbox"/>	106.50#	757	75	53
36 x 66"	RTEHA3666	<input type="checkbox"/> <input type="checkbox"/> <input type="checkbox"/>	<input type="checkbox"/> <input type="checkbox"/> <input type="checkbox"/>	<input type="checkbox"/> <input type="checkbox"/>	<input type="checkbox"/> <input type="checkbox"/> <input type="checkbox"/>	113.50#	761	75	53	
36 x 72"	RTEHA3672	<input type="checkbox"/> <input type="checkbox"/> <input type="checkbox"/>	<input type="checkbox"/> <input type="checkbox"/> <input type="checkbox"/>	<input type="checkbox"/> <input type="checkbox"/>	<input type="checkbox"/> <input type="checkbox"/> <input type="checkbox"/>	121.50#	768	75	53	

A **B** **C** **D** **E**

HOW TO ORDER

- Indicate the following information on order form:
1. Quantity of each item.
 2. Model number, including options. See "How To Build a Model Number".
 3. Any special service required.

Note: • The indicates that a choice is required.

- The absence of the indicates that no choice is required.
- Alpha-numeric characters in place of indicate that no other alternatives are available.

HOW TO BUILD A MODEL NUMBER

- A** Select basic model/edge style.
74P - 1-1/4" laminate top w/74P edge band
- B** Select edge color.
 Refer to the **Product Color Options** page in this price list.
- C** Select surface finish.
 Refer to the **Product Color Options** page in this price list.
- D** Select base finish.
 Refer to the **Product Color Options** page in this price list.
- E** Select base option.
GFT - Felt glides
GNV - Nylon glides

FINISH INFORMATION

Additional Laminate Offering

KI offers laminates beyond those offered in the standard offering. Laminates that are currently available in the program can be viewed in KI product specification tools. Requests to add laminates to the program can be submitted via the product modification request process. Please note, requests to add laminates to the program must include the laminate manufacturer's name, color/pattern number, and finish code. Edge options are limited to standard edge colors. If a matching edge is required, this will need to be requested through the product modification request process and may be subject to additional costs. Due to varying manufacturing processes and quality issues with some laminates, some requests may be denied. Extended lead times and minimum order quantities may apply on orders containing special laminates. Contact the product modification team for questions or additional information regarding special laminates and pricing.

SPECIAL SERVICES

Special Carton Marking

With specially marked information N/C

Shipping

Ships **knocked down**, FOB **Bonduel, WI 54107**, **freight excluded**. Freight class 70.

Specifications and prices are subject to change without prior notice.

Ruckus® Activity Table (Freight Excluded Pricing)

1-1/4" Top - 74P Edge



Ruckus® Activity Table (Freight Excluded Pricing)

1-1/4" Top - 74P Edge

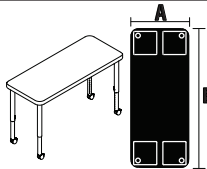
MODEL	A x B	MODEL NUMBER					Approx. Packaged Weight	Freight Excluded Pricing	Chrome Upcharge add to list price	Laminate Grade 2 add to list price
		Basic Model/Edge Style	Edge Color	Surface Finish	Base Finish	Base Option				
 <p>RTEEA</p> <p>Sit Height Adjustable Rectangular Rounded Corners Table, 20 to 33" H</p> <ul style="list-style-type: none"> • Casters and glides are interchangeable • Tables are designed for maximum leg spacing • All corners of surface are rounded • Specify casters/glides to wheelbarrow • Legs adjust with screws in 1" increments • Legs are factory pre-set at 29"H • 42x72, 44x72 and 48x72 have a center leg 	20 x 48"	RTEEA2048	<input type="checkbox"/>	<input type="checkbox"/>	<input type="checkbox"/>	<input type="checkbox"/>	69.30#	\$ 609	\$ 77	\$ 19
	20 x 54"	RTEEA2054	<input type="checkbox"/>	<input type="checkbox"/>	<input type="checkbox"/>	<input type="checkbox"/>	73.50#	625	77	19
	20 x 60"	RTEEA2060	<input type="checkbox"/>	<input type="checkbox"/>	<input type="checkbox"/>	<input type="checkbox"/>	77.70#	627	77	19
	20 x 66"	RTEEA2066	<input type="checkbox"/>	<input type="checkbox"/>	<input type="checkbox"/>	<input type="checkbox"/>	83.00#	602	77	19
	20 x 72"	RTEEA2072	<input type="checkbox"/>	<input type="checkbox"/>	<input type="checkbox"/>	<input type="checkbox"/>	86.00#	643	77	19
	24 x 30"	RTEEA2430	<input type="checkbox"/>	<input type="checkbox"/>	<input type="checkbox"/>	<input type="checkbox"/>	61.00#	581	77	19
	24 x 36"	RTEEA2436	<input type="checkbox"/>	<input type="checkbox"/>	<input type="checkbox"/>	<input type="checkbox"/>	66.00#	592	77	19
	24 x 48"	RTEEA2448	<input type="checkbox"/>	<input type="checkbox"/>	<input type="checkbox"/>	<input type="checkbox"/>	76.00#	609	77	19
	24 x 54"	RTEEA2454	<input type="checkbox"/>	<input type="checkbox"/>	<input type="checkbox"/>	<input type="checkbox"/>	81.00#	625	77	27
	24 x 60"	RTEEA2460	<input type="checkbox"/>	<input type="checkbox"/>	<input type="checkbox"/>	<input type="checkbox"/>	86.00#	627	77	27
	24 x 66"	RTEEA2466	<input type="checkbox"/>	<input type="checkbox"/>	<input type="checkbox"/>	<input type="checkbox"/>	92.00#	604	77	27
	24 x 72"	RTEEA2472	<input type="checkbox"/>	<input type="checkbox"/>	<input type="checkbox"/>	<input type="checkbox"/>	96.00#	643	77	27
	30 x 48"	RTEEA3048	<input type="checkbox"/>	<input type="checkbox"/>	<input type="checkbox"/>	<input type="checkbox"/>	86.00#	636	77	27
	30 x 54"	RTEEA3054	<input type="checkbox"/>	<input type="checkbox"/>	<input type="checkbox"/>	<input type="checkbox"/>	92.30#	657	77	27
	30 x 60"	RTEEA3060	<input type="checkbox"/>	<input type="checkbox"/>	<input type="checkbox"/>	<input type="checkbox"/>	98.50#	659	77	27
	30 x 66"	RTEEA3066	<input type="checkbox"/>	<input type="checkbox"/>	<input type="checkbox"/>	<input type="checkbox"/>	106.00#	622	77	27
	30 x 72"	RTEEA3072	<input type="checkbox"/>	<input type="checkbox"/>	<input type="checkbox"/>	<input type="checkbox"/>	111.00#	664	77	27
	36 x 54"	RTEEA3654	<input type="checkbox"/>	<input type="checkbox"/>	<input type="checkbox"/>	<input type="checkbox"/>	103.50#	808	77	53
	36 x 60"	RTEEA3660	<input type="checkbox"/>	<input type="checkbox"/>	<input type="checkbox"/>	<input type="checkbox"/>	111.00#	810	77	53
	36 x 66"	RTEEA3666	<input type="checkbox"/>	<input type="checkbox"/>	<input type="checkbox"/>	<input type="checkbox"/>	118.00#	764	77	53
	36 x 72"	RTEEA3672	<input type="checkbox"/>	<input type="checkbox"/>	<input type="checkbox"/>	<input type="checkbox"/>	126.00#	829	77	53
	42 x 60"	RTEEA4260	<input type="checkbox"/>	<input type="checkbox"/>	<input type="checkbox"/>	<input type="checkbox"/>	123.50#	809	77	53
	42 x 66"	RTEEA4266	<input type="checkbox"/>	<input type="checkbox"/>	<input type="checkbox"/>	<input type="checkbox"/>	130.00#	765	77	53
	42 x 72"	RTEEA4272	<input type="checkbox"/>	<input type="checkbox"/>	<input type="checkbox"/>	<input type="checkbox"/>	141.00#	809	77	53
	44 x 60"	RTEEA4460	<input type="checkbox"/>	<input type="checkbox"/>	<input type="checkbox"/>	<input type="checkbox"/>	127.70#	929	77	53
	44 x 66"	RTEEA4466	<input type="checkbox"/>	<input type="checkbox"/>	<input type="checkbox"/>	<input type="checkbox"/>	140.00#	878	77	53
	44 x 72"	RTEEA4472	<input type="checkbox"/>	<input type="checkbox"/>	<input type="checkbox"/>	<input type="checkbox"/>	146.00#	929	77	53
	48 x 60"	RTEEA4860	<input type="checkbox"/>	<input type="checkbox"/>	<input type="checkbox"/>	<input type="checkbox"/>	108.50#	926	77	53
48 x 66"	RTEEA4866	<input type="checkbox"/>	<input type="checkbox"/>	<input type="checkbox"/>	<input type="checkbox"/>	115.50#	926	77	53	
48 x 72"	RTEEA4872	<input type="checkbox"/>	<input type="checkbox"/>	<input type="checkbox"/>	<input type="checkbox"/>	123.50#	931	77	53	

A **B** **C** **D** **E**

HOW TO ORDER

- Indicate the following information on order form:
1. Quantity of each item.
 2. Model number, including options. See "How To Build a Model Number".
 3. Any special service required.

Note: • The indicates that a choice is required.
 • The absence of the indicates that no choice is required.
 • Alpha-numeric characters in place of indicate that no other alternatives are available.

HOW TO BUILD A MODEL NUMBER

- A** Select basic model/edge style.
74P - 1-1/4" laminate top w/74P edge band
- B** Select edge color.
 Refer to the **Product Color Options** page in this price list.
- C** Select surface finish.
 Refer to the **Product Color Options** page in this price list.
- D** Select base finish.
 Refer to the **Product Color Options** page in this price list.
- E** Select base option.

CCC	- Casters
BCF	- Casters/felt glides
BCN	- Casters/nylon glides
GFT	- Felt glides
GNV	- Nylon glides

FINISH INFORMATION

Additional Laminate Offering
 KI offers laminates beyond those offered in the standard offering. Laminates that are currently available in the program can be viewed in KI product specification tools. Requests to add laminates to the program can be submitted via the product modification request process. Please note, requests to add laminates to the program must include the laminate manufacturer's name, color/pattern number, and finish code. Edge options are limited to standard edge colors. If a matching edge is required, this will need to be requested through the product modification request process and may be subject to additional costs. Due to varying manufacturing processes and quality issues with some laminates, some requests may be denied. Extended lead times and minimum order quantities may apply on orders containing special laminates. Contact the product modification team for questions or additional information regarding special laminates and pricing.

SPECIAL SERVICES

Special Carton Marking

With specially marked information N/C

Shipping
 Ships **knocked down, FOB Bonduel, WI 54107, freight excluded.** Freight class 70.

Specifications and prices are subject to change without prior notice.

Ruckus® Activity Table (Freight Excluded Pricing)

1-1/4" Top - 74P Edge



Ruckus® Activity Table (Freight Excluded Pricing)

1-1/4" Top - 74P Edge

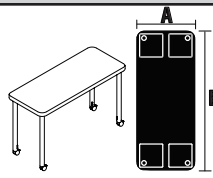
MODEL	A x B	MODEL NUMBER					Approx. Packaged Weight	Freight Excluded Pricing	Chrome Upcharge add to list price	Laminate Grade 2 add to list price
		Basic Model/Edge Style	Edge Color	Surface Finish	Base Finish	Base Option				
 <p>Sit-Stand Height Adjustable Rectangular Rounded Corners Table, 29 to 42" H</p> <ul style="list-style-type: none"> • Casters and glides are interchangeable • Tables are designed for maximum leg spacing • All corners of surface are rounded • Specify casters/glides to wheelbarrow • Legs adjust with screws in 1" increments • Legs are factory pre-set at 29"H • 42x72, 44x72 and 48x72 have a center leg 	20 x 48"	RTEFA2048	<input type="checkbox"/>	<input type="checkbox"/>	<input type="checkbox"/>	<input type="checkbox"/>	73.30#	\$ 657	\$ 88	\$ 19
	20 x 54"	RTEFA2054	<input type="checkbox"/>	<input type="checkbox"/>	<input type="checkbox"/>	<input type="checkbox"/>	77.50#	676	88	19
	20 x 60"	RTEFA2060	<input type="checkbox"/>	<input type="checkbox"/>	<input type="checkbox"/>	<input type="checkbox"/>	81.70#	678	88	19
	20 x 66"	RTEFA2066	<input type="checkbox"/>	<input type="checkbox"/>	<input type="checkbox"/>	<input type="checkbox"/>	87.00#	648	88	19
	20 x 72"	RTEFA2072	<input type="checkbox"/>	<input type="checkbox"/>	<input type="checkbox"/>	<input type="checkbox"/>	90.00#	692	88	19
	24 x 30"	RTEFA2430	<input type="checkbox"/>	<input type="checkbox"/>	<input type="checkbox"/>	<input type="checkbox"/>	65.00#	629	88	19
	24 x 36"	RTEFA2436	<input type="checkbox"/>	<input type="checkbox"/>	<input type="checkbox"/>	<input type="checkbox"/>	70.00#	641	88	19
	24 x 48"	RTEFA2448	<input type="checkbox"/>	<input type="checkbox"/>	<input type="checkbox"/>	<input type="checkbox"/>	80.00#	657	88	19
	24 x 54"	RTEFA2454	<input type="checkbox"/>	<input type="checkbox"/>	<input type="checkbox"/>	<input type="checkbox"/>	85.00#	676	88	27
	24 x 60"	RTEFA2460	<input type="checkbox"/>	<input type="checkbox"/>	<input type="checkbox"/>	<input type="checkbox"/>	90.00#	678	88	27
	24 x 66"	RTEFA2466	<input type="checkbox"/>	<input type="checkbox"/>	<input type="checkbox"/>	<input type="checkbox"/>	96.00#	650	88	27
	24 x 72"	RTEFA2472	<input type="checkbox"/>	<input type="checkbox"/>	<input type="checkbox"/>	<input type="checkbox"/>	100.00#	692	88	27
	30 x 48"	RTEFA3048	<input type="checkbox"/>	<input type="checkbox"/>	<input type="checkbox"/>	<input type="checkbox"/>	90.00#	687	88	27
	30 x 54"	RTEFA3054	<input type="checkbox"/>	<input type="checkbox"/>	<input type="checkbox"/>	<input type="checkbox"/>	96.30#	711	88	27
	30 x 60"	RTEFA3060	<input type="checkbox"/>	<input type="checkbox"/>	<input type="checkbox"/>	<input type="checkbox"/>	102.50#	712	88	27
	30 x 66"	RTEFA3066	<input type="checkbox"/>	<input type="checkbox"/>	<input type="checkbox"/>	<input type="checkbox"/>	110.00#	672	88	27
	30 x 72"	RTEFA3072	<input type="checkbox"/>	<input type="checkbox"/>	<input type="checkbox"/>	<input type="checkbox"/>	115.00#	715	88	27
	36 x 54"	RTEFA3654	<input type="checkbox"/>	<input type="checkbox"/>	<input type="checkbox"/>	<input type="checkbox"/>	107.50#	869	88	53
	36 x 60"	RTEFA3660	<input type="checkbox"/>	<input type="checkbox"/>	<input type="checkbox"/>	<input type="checkbox"/>	115.00#	871	88	53
	36 x 66"	RTEFA3666	<input type="checkbox"/>	<input type="checkbox"/>	<input type="checkbox"/>	<input type="checkbox"/>	122.00#	820	88	53
	36 x 72"	RTEFA3672	<input type="checkbox"/>	<input type="checkbox"/>	<input type="checkbox"/>	<input type="checkbox"/>	130.00#	891	88	53
	42 x 60"	RTEFA4260	<input type="checkbox"/>	<input type="checkbox"/>	<input type="checkbox"/>	<input type="checkbox"/>	127.50#	869	88	53
	42 x 66"	RTEFA4266	<input type="checkbox"/>	<input type="checkbox"/>	<input type="checkbox"/>	<input type="checkbox"/>	134.00#	822	88	53
	42 x 72"	RTEFA4272	<input type="checkbox"/>	<input type="checkbox"/>	<input type="checkbox"/>	<input type="checkbox"/>	145.00#	869	88	53
	44 x 60"	RTEFA4460	<input type="checkbox"/>	<input type="checkbox"/>	<input type="checkbox"/>	<input type="checkbox"/>	131.70#	997	88	53
	44 x 66"	RTEFA4466	<input type="checkbox"/>	<input type="checkbox"/>	<input type="checkbox"/>	<input type="checkbox"/>	144.00#	943	88	53
	44 x 72"	RTEFA4472	<input type="checkbox"/>	<input type="checkbox"/>	<input type="checkbox"/>	<input type="checkbox"/>	150.00#	997	88	53
	48 x 60"	RTEFA4860	<input type="checkbox"/>	<input type="checkbox"/>	<input type="checkbox"/>	<input type="checkbox"/>	140.00#	990	88	53
48 x 66"	RTEFA4866	<input type="checkbox"/>	<input type="checkbox"/>	<input type="checkbox"/>	<input type="checkbox"/>	152.00#	992	88	53	
48 x 72"	RTEFA4872	<input type="checkbox"/>	<input type="checkbox"/>	<input type="checkbox"/>	<input type="checkbox"/>	153.00#	994	88	53	

A **B** **C** **D** **E**

HOW TO ORDER

- Indicate the following information on order form:
1. Quantity of each item.
 2. Model number, including options. See "How To Build a Model Number".
 3. Any special service required.

Note: • The indicates that a choice is required.
 • The absence of the indicates that no choice is required.
 • Alpha-numeric characters in place of indicate that no other alternatives are available.

HOW TO BUILD A MODEL NUMBER

- A** Select basic model/edge style.
74P - 1-1/4" laminate top w/74P edge band
- B** Select edge color.
 Refer to the **Product Color Options** page in this price list.
- C** Select surface finish.
 Refer to the **Product Color Options** page in this price list.
- D** Select base finish.
 Refer to the **Product Color Options** page in this price list.
- E** Select base option.

CCC	- Casters
BCF	- Casters/felt glides
BCN	- Casters/nylon glides
GFT	- Felt glides
GNV	- Nylon glides

FINISH INFORMATION

Additional Laminate Offering
 KI offers laminates beyond those offered in the standard offering. Laminates that are currently available in the program can be viewed in KI product specification tools. Requests to add laminates to the program can be submitted via the product modification request process. Please note, requests to add laminates to the program must include the laminate manufacturer's name, color/pattern number, and finish code. Edge options are limited to standard edge colors. If a matching edge is required, this will need to be requested through the product modification request process and may be subject to additional costs. Due to varying manufacturing processes and quality issues with some laminates, some requests may be denied. Extended lead times and minimum order quantities may apply on orders containing special laminates. Contact the product modification team for questions or additional information regarding special laminates and pricing.

SPECIAL SERVICES

Special Carton Marking

With specially marked information N/C

Shipping
 Ships **knocked down, FOB Bonduel, WI 54107, freight excluded.** Freight class 70.

Specifications and prices are subject to change without prior notice.

Ruckus® Activity Table (Freight Excluded Pricing)

1-1/4" Top - 74P Edge



Ruckus® Activity Table (Freight Excluded Pricing)

1-1/4" Top - 74P Edge

MODEL	A x B	MODEL NUMBER					Approx. Packaged Weight	Freight Excluded Pricing	Chrome Upcharge add to list price	Laminate Grade 2 add to list price
		Basic Model/Edge Style	Edge Color	Surface Finish	Base Finish	Base Option				
Fixed Height Rectangular Square Corners Table, 29" H • Casters and glides are interchangeable • Tables are designed for maximum leg spacing • All corners of surface are squared • Specify casters/glides to wheelbarrow • 42x72, 44x72 and 48x72 have a center leg	20 x 48"	RXEEA2048	<input type="checkbox"/> <input type="checkbox"/> <input type="checkbox"/>	<input type="checkbox"/> <input type="checkbox"/> <input type="checkbox"/>	<input type="checkbox"/> <input type="checkbox"/>	<input type="checkbox"/> <input type="checkbox"/>	68.00#	\$ 527	\$ 70	\$ 19
	20 x 54"	RXEEA2054	<input type="checkbox"/> <input type="checkbox"/> <input type="checkbox"/>	<input type="checkbox"/> <input type="checkbox"/> <input type="checkbox"/>	<input type="checkbox"/> <input type="checkbox"/>	<input type="checkbox"/> <input type="checkbox"/>	72.00#	541	70	19
	20 x 60"	RXEEA2060	<input type="checkbox"/> <input type="checkbox"/> <input type="checkbox"/>	<input type="checkbox"/> <input type="checkbox"/> <input type="checkbox"/>	<input type="checkbox"/> <input type="checkbox"/>	<input type="checkbox"/> <input type="checkbox"/>	77.00#	544	70	19
	20 x 66"	RXEEA2066	<input type="checkbox"/> <input type="checkbox"/> <input type="checkbox"/>	<input type="checkbox"/> <input type="checkbox"/> <input type="checkbox"/>	<input type="checkbox"/> <input type="checkbox"/>	<input type="checkbox"/> <input type="checkbox"/>	82.00#	555	70	19
	20 x 72"	RXEEA2072	<input type="checkbox"/> <input type="checkbox"/> <input type="checkbox"/>	<input type="checkbox"/> <input type="checkbox"/> <input type="checkbox"/>	<input type="checkbox"/> <input type="checkbox"/>	<input type="checkbox"/> <input type="checkbox"/>	85.00#	563	70	19
	24 x 30"	RXEEA2430	<input type="checkbox"/> <input type="checkbox"/> <input type="checkbox"/>	<input type="checkbox"/> <input type="checkbox"/> <input type="checkbox"/>	<input type="checkbox"/> <input type="checkbox"/>	<input type="checkbox"/> <input type="checkbox"/>	60.00#	500	70	19
	24 x 36"	RXEEA2436	<input type="checkbox"/> <input type="checkbox"/> <input type="checkbox"/>	<input type="checkbox"/> <input type="checkbox"/> <input type="checkbox"/>	<input type="checkbox"/> <input type="checkbox"/>	<input type="checkbox"/> <input type="checkbox"/>	65.00#	511	70	19
	24 x 48"	RXEEA2448	<input type="checkbox"/> <input type="checkbox"/> <input type="checkbox"/>	<input type="checkbox"/> <input type="checkbox"/> <input type="checkbox"/>	<input type="checkbox"/> <input type="checkbox"/>	<input type="checkbox"/> <input type="checkbox"/>	75.00#	527	70	19
	24 x 54"	RXEEA2454	<input type="checkbox"/> <input type="checkbox"/> <input type="checkbox"/>	<input type="checkbox"/> <input type="checkbox"/> <input type="checkbox"/>	<input type="checkbox"/> <input type="checkbox"/>	<input type="checkbox"/> <input type="checkbox"/>	80.00#	541	70	27
	24 x 60"	RXEEA2460	<input type="checkbox"/> <input type="checkbox"/> <input type="checkbox"/>	<input type="checkbox"/> <input type="checkbox"/> <input type="checkbox"/>	<input type="checkbox"/> <input type="checkbox"/>	<input type="checkbox"/> <input type="checkbox"/>	85.00#	544	70	27
	24 x 66"	RXEEA2466	<input type="checkbox"/> <input type="checkbox"/> <input type="checkbox"/>	<input type="checkbox"/> <input type="checkbox"/> <input type="checkbox"/>	<input type="checkbox"/> <input type="checkbox"/>	<input type="checkbox"/> <input type="checkbox"/>	91.00#	558	70	27
	24 x 72"	RXEEA2472	<input type="checkbox"/> <input type="checkbox"/> <input type="checkbox"/>	<input type="checkbox"/> <input type="checkbox"/> <input type="checkbox"/>	<input type="checkbox"/> <input type="checkbox"/>	<input type="checkbox"/> <input type="checkbox"/>	95.00#	563	70	27
	30 x 48"	RXEEA3048	<input type="checkbox"/> <input type="checkbox"/> <input type="checkbox"/>	<input type="checkbox"/> <input type="checkbox"/> <input type="checkbox"/>	<input type="checkbox"/> <input type="checkbox"/>	<input type="checkbox"/> <input type="checkbox"/>	85.00#	555	70	27
	30 x 54"	RXEEA3054	<input type="checkbox"/> <input type="checkbox"/> <input type="checkbox"/>	<input type="checkbox"/> <input type="checkbox"/> <input type="checkbox"/>	<input type="checkbox"/> <input type="checkbox"/>	<input type="checkbox"/> <input type="checkbox"/>	91.00#	577	70	27
	30 x 60"	RXEEA3060	<input type="checkbox"/> <input type="checkbox"/> <input type="checkbox"/>	<input type="checkbox"/> <input type="checkbox"/> <input type="checkbox"/>	<input type="checkbox"/> <input type="checkbox"/>	<input type="checkbox"/> <input type="checkbox"/>	98.00#	567	70	27
	30 x 66"	RXEEA3066	<input type="checkbox"/> <input type="checkbox"/> <input type="checkbox"/>	<input type="checkbox"/> <input type="checkbox"/> <input type="checkbox"/>	<input type="checkbox"/> <input type="checkbox"/>	<input type="checkbox"/> <input type="checkbox"/>	105.00#	580	70	27
	30 x 72"	RXEEA3072	<input type="checkbox"/> <input type="checkbox"/> <input type="checkbox"/>	<input type="checkbox"/> <input type="checkbox"/> <input type="checkbox"/>	<input type="checkbox"/> <input type="checkbox"/>	<input type="checkbox"/> <input type="checkbox"/>	110.00#	584	70	27
	36 x 54"	RXEEA3654	<input type="checkbox"/> <input type="checkbox"/> <input type="checkbox"/>	<input type="checkbox"/> <input type="checkbox"/> <input type="checkbox"/>	<input type="checkbox"/> <input type="checkbox"/>	<input type="checkbox"/> <input type="checkbox"/>	103.00#	719	70	53
	36 x 60"	RXEEA3660	<input type="checkbox"/> <input type="checkbox"/> <input type="checkbox"/>	<input type="checkbox"/> <input type="checkbox"/> <input type="checkbox"/>	<input type="checkbox"/> <input type="checkbox"/>	<input type="checkbox"/> <input type="checkbox"/>	110.00#	721	70	53
	36 x 66"	RXEEA3666	<input type="checkbox"/> <input type="checkbox"/> <input type="checkbox"/>	<input type="checkbox"/> <input type="checkbox"/> <input type="checkbox"/>	<input type="checkbox"/> <input type="checkbox"/>	<input type="checkbox"/> <input type="checkbox"/>	117.00#	724	70	53
	36 x 72"	RXEEA3672	<input type="checkbox"/> <input type="checkbox"/> <input type="checkbox"/>	<input type="checkbox"/> <input type="checkbox"/> <input type="checkbox"/>	<input type="checkbox"/> <input type="checkbox"/>	<input type="checkbox"/> <input type="checkbox"/>	125.00#	730	70	53
	42 x 60"	RXEEA4260	<input type="checkbox"/> <input type="checkbox"/> <input type="checkbox"/>	<input type="checkbox"/> <input type="checkbox"/> <input type="checkbox"/>	<input type="checkbox"/> <input type="checkbox"/>	<input type="checkbox"/> <input type="checkbox"/>	123.00#	725	70	53
	42 x 66"	RXEEA4266	<input type="checkbox"/> <input type="checkbox"/> <input type="checkbox"/>	<input type="checkbox"/> <input type="checkbox"/> <input type="checkbox"/>	<input type="checkbox"/> <input type="checkbox"/>	<input type="checkbox"/> <input type="checkbox"/>	129.00#	728	70	53
	42 x 72"	RXEEA4272	<input type="checkbox"/> <input type="checkbox"/> <input type="checkbox"/>	<input type="checkbox"/> <input type="checkbox"/> <input type="checkbox"/>	<input type="checkbox"/> <input type="checkbox"/>	<input type="checkbox"/> <input type="checkbox"/>	140.00#	731	70	53
	44 x 60"	RXEEA4460	<input type="checkbox"/> <input type="checkbox"/> <input type="checkbox"/>	<input type="checkbox"/> <input type="checkbox"/> <input type="checkbox"/>	<input type="checkbox"/> <input type="checkbox"/>	<input type="checkbox"/> <input type="checkbox"/>	127.00#	843	70	53
	44 x 66"	RXEEA4466	<input type="checkbox"/> <input type="checkbox"/> <input type="checkbox"/>	<input type="checkbox"/> <input type="checkbox"/> <input type="checkbox"/>	<input type="checkbox"/> <input type="checkbox"/>	<input type="checkbox"/> <input type="checkbox"/>	139.00#	845	70	53
	44 x 72"	RXEEA4472	<input type="checkbox"/> <input type="checkbox"/> <input type="checkbox"/>	<input type="checkbox"/> <input type="checkbox"/> <input type="checkbox"/>	<input type="checkbox"/> <input type="checkbox"/>	<input type="checkbox"/> <input type="checkbox"/>	145.00#	847	70	53
	48 x 60"	RXEEA4860	<input type="checkbox"/> <input type="checkbox"/> <input type="checkbox"/>	<input type="checkbox"/> <input type="checkbox"/> <input type="checkbox"/>	<input type="checkbox"/> <input type="checkbox"/>	<input type="checkbox"/> <input type="checkbox"/>	137.00#	890	70	53
48 x 66"	RXEEA4866	<input type="checkbox"/> <input type="checkbox"/> <input type="checkbox"/>	<input type="checkbox"/> <input type="checkbox"/> <input type="checkbox"/>	<input type="checkbox"/> <input type="checkbox"/>	<input type="checkbox"/> <input type="checkbox"/>	149.00#	892	70	53	
48 x 72"	RXEEA4872	<input type="checkbox"/> <input type="checkbox"/> <input type="checkbox"/>	<input type="checkbox"/> <input type="checkbox"/> <input type="checkbox"/>	<input type="checkbox"/> <input type="checkbox"/>	<input type="checkbox"/> <input type="checkbox"/>	150.00#	894	70	53	

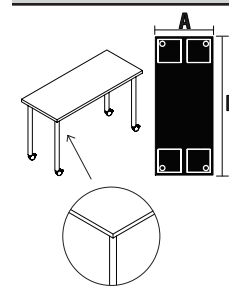

RXEAA

A **B** **C** **D** **E**

HOW TO ORDER

- Indicate the following information on order form:
- Quantity of each item.
 - Model number, including options. See "How To Build a Model Number".
 - Any special service required.

Note: • The indicates that a choice is required.
 • The absence of the indicates that no choice is required.
 • Alpha-numeric characters in place of indicate that no other alternatives are available.

HOW TO BUILD A MODEL NUMBER

- A** Select basic model/edge style.
74P - 1-1/4" laminate top w/74P edge band
- B** Select edge color.
 Refer to the **Product Color Options** page in this price list.
- C** Select surface finish.
 Refer to the **Product Color Options** page in this price list.
- D** Select base finish.
 Refer to the **Product Color Options** page in this price list.
- E** Select base option.
- | | |
|------------|------------------------|
| CCC | - Casters |
| BCF | - Casters/felt glides |
| BCN | - Casters/nylon glides |
| GFT | - Felt glides |
| GNV | - Nylon glides |

FINISH INFORMATION

Additional Laminate Offering
 KI offers laminates beyond those offered in the standard offering. Laminates that are currently available in the program can be viewed in KI product specification tools. Requests to add laminates to the program can be submitted via the product modification request process. Please note, requests to add laminates to the program must include the laminate manufacturer's name, color/pattern number, and finish code. Edge options are limited to standard edge colors. If a matching edge is required, this will need to be requested through the product modification request process and may be subject to additional costs. Due to varying manufacturing processes and quality issues with some laminates, some requests may be denied. Extended lead times and minimum order quantities may apply on orders containing special laminates. Contact the product modification team for questions or additional information regarding special laminates and pricing.

SPECIAL SERVICES

Special Carton Marking
 With specially marked information N/C

Shipping
 Ships **knocked down, FOB Bonduel, WI 54107, freight excluded.** Freight class 70.

Specifications and prices are subject to change without prior notice.

Ruckus® Activity Table (Freight Excluded Pricing)

1-1/4" Top - 74P Edge



Ruckus® Activity Table (Freight Excluded Pricing)

1-1/4" Top - 74P Edge

MODEL	A x B	MODEL NUMBER					Approx. Packaged Weight	Freight Excluded Pricing	Chrome Upcharge add to list price	Laminate Grade 2 add to list price
		Basic Model/Edge Style	Edge Color	Surface Finish	Base Finish	Base Option				
Sit Height Adjustable Rectangle Square Corners Table, 20 to 33" H • Casters and glides are interchangeable • Tables are designed for maximum leg spacing • All corners of surface are squared • Specify casters/glides to wheelbarrow • Legs adjust with screws in 1" increments • Legs are factory pre-set at 29"H • 42x72, 44x72 and 48x72 have a center leg	20 x 48"	RXEEA2048	<input type="checkbox"/> <input type="checkbox"/> <input type="checkbox"/>	<input type="checkbox"/> <input type="checkbox"/> <input type="checkbox"/>	<input type="checkbox"/> <input type="checkbox"/> <input type="checkbox"/>	<input type="checkbox"/> <input type="checkbox"/> <input type="checkbox"/>	70.00#	\$ 576	\$ 77	\$ 19
	20 x 54"	RXEEA2054	<input type="checkbox"/> <input type="checkbox"/> <input type="checkbox"/>	<input type="checkbox"/> <input type="checkbox"/> <input type="checkbox"/>	<input type="checkbox"/> <input type="checkbox"/> <input type="checkbox"/>	<input type="checkbox"/> <input type="checkbox"/> <input type="checkbox"/>	74.00#	589	77	19
	20 x 60"	RXEEA2060	<input type="checkbox"/> <input type="checkbox"/> <input type="checkbox"/>	<input type="checkbox"/> <input type="checkbox"/> <input type="checkbox"/>	<input type="checkbox"/> <input type="checkbox"/> <input type="checkbox"/>	<input type="checkbox"/> <input type="checkbox"/> <input type="checkbox"/>	79.00#	591	77	19
	20 x 66"	RXEEA2066	<input type="checkbox"/> <input type="checkbox"/> <input type="checkbox"/>	<input type="checkbox"/> <input type="checkbox"/> <input type="checkbox"/>	<input type="checkbox"/> <input type="checkbox"/> <input type="checkbox"/>	<input type="checkbox"/> <input type="checkbox"/> <input type="checkbox"/>	84.00#	602	77	19
	20 x 72"	RXEEA2072	<input type="checkbox"/> <input type="checkbox"/> <input type="checkbox"/>	<input type="checkbox"/> <input type="checkbox"/> <input type="checkbox"/>	<input type="checkbox"/> <input type="checkbox"/> <input type="checkbox"/>	<input type="checkbox"/> <input type="checkbox"/> <input type="checkbox"/>	87.00#	608	77	19
	24 x 30"	RXEEA2430	<input type="checkbox"/> <input type="checkbox"/> <input type="checkbox"/>	<input type="checkbox"/> <input type="checkbox"/> <input type="checkbox"/>	<input type="checkbox"/> <input type="checkbox"/> <input type="checkbox"/>	<input type="checkbox"/> <input type="checkbox"/> <input type="checkbox"/>	62.00#	550	77	19
	24 x 36"	RXEEA2436	<input type="checkbox"/> <input type="checkbox"/> <input type="checkbox"/>	<input type="checkbox"/> <input type="checkbox"/> <input type="checkbox"/>	<input type="checkbox"/> <input type="checkbox"/> <input type="checkbox"/>	<input type="checkbox"/> <input type="checkbox"/> <input type="checkbox"/>	67.00#	560	77	19
	24 x 48"	RXEEA2448	<input type="checkbox"/> <input type="checkbox"/> <input type="checkbox"/>	<input type="checkbox"/> <input type="checkbox"/> <input type="checkbox"/>	<input type="checkbox"/> <input type="checkbox"/> <input type="checkbox"/>	<input type="checkbox"/> <input type="checkbox"/> <input type="checkbox"/>	77.00#	576	77	19
	24 x 54"	RXEEA2454	<input type="checkbox"/> <input type="checkbox"/> <input type="checkbox"/>	<input type="checkbox"/> <input type="checkbox"/> <input type="checkbox"/>	<input type="checkbox"/> <input type="checkbox"/> <input type="checkbox"/>	<input type="checkbox"/> <input type="checkbox"/> <input type="checkbox"/>	82.00#	589	77	27
	24 x 60"	RXEEA2460	<input type="checkbox"/> <input type="checkbox"/> <input type="checkbox"/>	<input type="checkbox"/> <input type="checkbox"/> <input type="checkbox"/>	<input type="checkbox"/> <input type="checkbox"/> <input type="checkbox"/>	<input type="checkbox"/> <input type="checkbox"/> <input type="checkbox"/>	87.00#	591	77	27
	24 x 66"	RXEEA2466	<input type="checkbox"/> <input type="checkbox"/> <input type="checkbox"/>	<input type="checkbox"/> <input type="checkbox"/> <input type="checkbox"/>	<input type="checkbox"/> <input type="checkbox"/> <input type="checkbox"/>	<input type="checkbox"/> <input type="checkbox"/> <input type="checkbox"/>	93.00#	604	77	27
	24 x 72"	RXEEA2472	<input type="checkbox"/> <input type="checkbox"/> <input type="checkbox"/>	<input type="checkbox"/> <input type="checkbox"/> <input type="checkbox"/>	<input type="checkbox"/> <input type="checkbox"/> <input type="checkbox"/>	<input type="checkbox"/> <input type="checkbox"/> <input type="checkbox"/>	97.00#	608	77	27
	30 x 48"	RXEEA3048	<input type="checkbox"/> <input type="checkbox"/> <input type="checkbox"/>	<input type="checkbox"/> <input type="checkbox"/> <input type="checkbox"/>	<input type="checkbox"/> <input type="checkbox"/> <input type="checkbox"/>	<input type="checkbox"/> <input type="checkbox"/> <input type="checkbox"/>	87.00#	602	77	27
	30 x 54"	RXEEA3054	<input type="checkbox"/> <input type="checkbox"/> <input type="checkbox"/>	<input type="checkbox"/> <input type="checkbox"/> <input type="checkbox"/>	<input type="checkbox"/> <input type="checkbox"/> <input type="checkbox"/>	<input type="checkbox"/> <input type="checkbox"/> <input type="checkbox"/>	93.00#	619	77	27
	30 x 60"	RXEEA3060	<input type="checkbox"/> <input type="checkbox"/> <input type="checkbox"/>	<input type="checkbox"/> <input type="checkbox"/> <input type="checkbox"/>	<input type="checkbox"/> <input type="checkbox"/> <input type="checkbox"/>	<input type="checkbox"/> <input type="checkbox"/> <input type="checkbox"/>	100.00#	621	77	27
	30 x 66"	RXEEA3066	<input type="checkbox"/> <input type="checkbox"/> <input type="checkbox"/>	<input type="checkbox"/> <input type="checkbox"/> <input type="checkbox"/>	<input type="checkbox"/> <input type="checkbox"/> <input type="checkbox"/>	<input type="checkbox"/> <input type="checkbox"/> <input type="checkbox"/>	107.00#	622	77	27
	30 x 72"	RXEEA3072	<input type="checkbox"/> <input type="checkbox"/> <input type="checkbox"/>	<input type="checkbox"/> <input type="checkbox"/> <input type="checkbox"/>	<input type="checkbox"/> <input type="checkbox"/> <input type="checkbox"/>	<input type="checkbox"/> <input type="checkbox"/> <input type="checkbox"/>	112.00#	628	77	27
	36 x 54"	RXEEA3654	<input type="checkbox"/> <input type="checkbox"/> <input type="checkbox"/>	<input type="checkbox"/> <input type="checkbox"/> <input type="checkbox"/>	<input type="checkbox"/> <input type="checkbox"/> <input type="checkbox"/>	<input type="checkbox"/> <input type="checkbox"/> <input type="checkbox"/>	105.00#	761	77	53
	36 x 60"	RXEEA3660	<input type="checkbox"/> <input type="checkbox"/> <input type="checkbox"/>	<input type="checkbox"/> <input type="checkbox"/> <input type="checkbox"/>	<input type="checkbox"/> <input type="checkbox"/> <input type="checkbox"/>	<input type="checkbox"/> <input type="checkbox"/> <input type="checkbox"/>	112.00#	764	77	53
	36 x 66"	RXEEA3666	<input type="checkbox"/> <input type="checkbox"/> <input type="checkbox"/>	<input type="checkbox"/> <input type="checkbox"/> <input type="checkbox"/>	<input type="checkbox"/> <input type="checkbox"/> <input type="checkbox"/>	<input type="checkbox"/> <input type="checkbox"/> <input type="checkbox"/>	119.00#	766	77	53
	36 x 72"	RXEEA3672	<input type="checkbox"/> <input type="checkbox"/> <input type="checkbox"/>	<input type="checkbox"/> <input type="checkbox"/> <input type="checkbox"/>	<input type="checkbox"/> <input type="checkbox"/> <input type="checkbox"/>	<input type="checkbox"/> <input type="checkbox"/> <input type="checkbox"/>	127.00#	770	77	53
	42 x 60"	RXEEA4260	<input type="checkbox"/> <input type="checkbox"/> <input type="checkbox"/>	<input type="checkbox"/> <input type="checkbox"/> <input type="checkbox"/>	<input type="checkbox"/> <input type="checkbox"/> <input type="checkbox"/>	<input type="checkbox"/> <input type="checkbox"/> <input type="checkbox"/>	125.00#	765	77	53
	42 x 66"	RXEEA4266	<input type="checkbox"/> <input type="checkbox"/> <input type="checkbox"/>	<input type="checkbox"/> <input type="checkbox"/> <input type="checkbox"/>	<input type="checkbox"/> <input type="checkbox"/> <input type="checkbox"/>	<input type="checkbox"/> <input type="checkbox"/> <input type="checkbox"/>	131.00#	767	77	53
	42 x 72"	RXEEA4272	<input type="checkbox"/> <input type="checkbox"/> <input type="checkbox"/>	<input type="checkbox"/> <input type="checkbox"/> <input type="checkbox"/>	<input type="checkbox"/> <input type="checkbox"/> <input type="checkbox"/>	<input type="checkbox"/> <input type="checkbox"/> <input type="checkbox"/>	142.00#	770	77	53
	44 x 60"	RXEEA4460	<input type="checkbox"/> <input type="checkbox"/> <input type="checkbox"/>	<input type="checkbox"/> <input type="checkbox"/> <input type="checkbox"/>	<input type="checkbox"/> <input type="checkbox"/> <input type="checkbox"/>	<input type="checkbox"/> <input type="checkbox"/> <input type="checkbox"/>	129.00#	878	77	53
	44 x 66"	RXEEA4466	<input type="checkbox"/> <input type="checkbox"/> <input type="checkbox"/>	<input type="checkbox"/> <input type="checkbox"/> <input type="checkbox"/>	<input type="checkbox"/> <input type="checkbox"/> <input type="checkbox"/>	<input type="checkbox"/> <input type="checkbox"/> <input type="checkbox"/>	141.00#	881	77	53
	44 x 72"	RXEEA4472	<input type="checkbox"/> <input type="checkbox"/> <input type="checkbox"/>	<input type="checkbox"/> <input type="checkbox"/> <input type="checkbox"/>	<input type="checkbox"/> <input type="checkbox"/> <input type="checkbox"/>	<input type="checkbox"/> <input type="checkbox"/> <input type="checkbox"/>	147.00#	884	77	53
	48 x 60"	RXEEA4860	<input type="checkbox"/> <input type="checkbox"/> <input type="checkbox"/>	<input type="checkbox"/> <input type="checkbox"/> <input type="checkbox"/>	<input type="checkbox"/> <input type="checkbox"/> <input type="checkbox"/>	<input type="checkbox"/> <input type="checkbox"/> <input type="checkbox"/>	139.00#	926	77	53
48 x 66"	RXEEA4866	<input type="checkbox"/> <input type="checkbox"/> <input type="checkbox"/>	<input type="checkbox"/> <input type="checkbox"/> <input type="checkbox"/>	<input type="checkbox"/> <input type="checkbox"/> <input type="checkbox"/>	<input type="checkbox"/> <input type="checkbox"/> <input type="checkbox"/>	151.00#	929	77	53	
48 x 72"	RXEEA4872	<input type="checkbox"/> <input type="checkbox"/> <input type="checkbox"/>	<input type="checkbox"/> <input type="checkbox"/> <input type="checkbox"/>	<input type="checkbox"/> <input type="checkbox"/> <input type="checkbox"/>	<input type="checkbox"/> <input type="checkbox"/> <input type="checkbox"/>	152.00#	931	77	53	

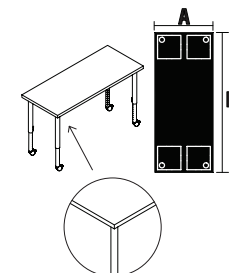

RXEEA

A **B** **C** **D** **E**

HOW TO ORDER

- Indicate the following information on order form:
- Quantity of each item.
 - Model number, including options. See "How To Build a Model Number".
 - Any special service required.

Note: • The indicates that a choice is required.
 • The absence of the indicates that no choice is required.
 • Alpha-numeric characters in place of indicate that no other alternatives are available.

HOW TO BUILD A MODEL NUMBER

- A** Select basic model/edge style.
74P - 1-1/4" laminate top w/74P edge band
- B** Select edge color.
 Refer to the **Product Color Options** page in this price list.
- C** Select surface finish.
 Refer to the **Product Color Options** page in this price list.
- D** Select base finish.
 Refer to the **Product Color Options** page in this price list.
- E** Select base option.
- | | |
|------------|------------------------|
| CCC | - Casters |
| BCF | - Casters/felt glides |
| BCN | - Casters/nylon glides |
| GFT | - Felt glides |
| GNV | - Nylon glides |

FINISH INFORMATION

Additional Laminate Offering
 KI offers laminates beyond those offered in the standard offering. Laminates that are currently available in the program can be viewed in KI product specification tools. Requests to add laminates to the program can be submitted via the product modification request process. Please note, requests to add laminates to the program must include the laminate manufacturer's name, color/pattern number, and finish code. Edge options are limited to standard edge colors. If a matching edge is required, this will need to be requested through the product modification request process and may be subject to additional costs. Due to varying manufacturing processes and quality issues with some laminates, some requests may be denied. Extended lead times and minimum order quantities may apply on orders containing special laminates. Contact the product modification team for questions or additional information regarding special laminates and pricing.

SPECIAL SERVICES

Special Carton Marking
 With specially marked information N/C

Shipping
 Ships **knocked down, FOB Bonduel, WI 54107, freight excluded.** Freight class 70.

Specifications and prices are subject to change without prior notice.

Ruckus® Activity Table (Freight Excluded Pricing)

1-1/4" Top - 74P Edge



Ruckus® Activity Table (Freight Excluded Pricing)

1-1/4" Top - 74P Edge

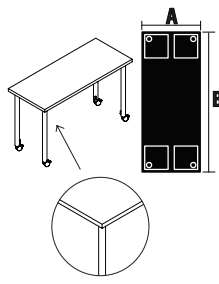
MODEL	A x B	MODEL NUMBER					Approx. Packaged Weight	Freight Excluded Pricing	Chrome Upcharge add to list price	Laminate Grade 2 add to list price
		Basic Model/Edge Style	Edge Color	Surface Finish	Base Finish	Base Option				
 <p>Sit-Stand Height Adjustable Rectangular Squared Corners Table, 29 to 42" H</p> <ul style="list-style-type: none"> • Casters and glides are interchangeable • Tables are designed for maximum leg spacing • All corners of surface are squared • Specify casters/glides to wheelbarrow • Legs adjust with screws in 1" increments • Legs are factory pre-set at 29"H • 42x72, 44x72 and 48x72 have a center leg 	20 x 48"	RXEFA2048	<input type="checkbox"/> <input type="checkbox"/> <input type="checkbox"/>	<input type="checkbox"/> <input type="checkbox"/> <input type="checkbox"/>	<input type="checkbox"/> <input type="checkbox"/>	<input type="checkbox"/> <input type="checkbox"/>	74.00#	\$ 621	\$ 88	\$ 19
	20 x 54"	RXEFA2054	<input type="checkbox"/> <input type="checkbox"/> <input type="checkbox"/>	<input type="checkbox"/> <input type="checkbox"/> <input type="checkbox"/>	<input type="checkbox"/> <input type="checkbox"/>	<input type="checkbox"/> <input type="checkbox"/>	78.00#	637	88	19
	20 x 60"	RXEFA2060	<input type="checkbox"/> <input type="checkbox"/> <input type="checkbox"/>	<input type="checkbox"/> <input type="checkbox"/> <input type="checkbox"/>	<input type="checkbox"/> <input type="checkbox"/>	<input type="checkbox"/> <input type="checkbox"/>	83.00#	639	88	19
	20 x 66"	RXEFA2066	<input type="checkbox"/> <input type="checkbox"/> <input type="checkbox"/>	<input type="checkbox"/> <input type="checkbox"/> <input type="checkbox"/>	<input type="checkbox"/> <input type="checkbox"/>	<input type="checkbox"/> <input type="checkbox"/>	88.00#	648	88	19
	20 x 72"	RXEFA2072	<input type="checkbox"/> <input type="checkbox"/> <input type="checkbox"/>	<input type="checkbox"/> <input type="checkbox"/> <input type="checkbox"/>	<input type="checkbox"/> <input type="checkbox"/>	<input type="checkbox"/> <input type="checkbox"/>	91.00#	655	88	19
	24 x 30"	RXEFA2430	<input type="checkbox"/> <input type="checkbox"/> <input type="checkbox"/>	<input type="checkbox"/> <input type="checkbox"/> <input type="checkbox"/>	<input type="checkbox"/> <input type="checkbox"/>	<input type="checkbox"/> <input type="checkbox"/>	66.00#	594	88	19
	24 x 36"	RXEFA2436	<input type="checkbox"/> <input type="checkbox"/> <input type="checkbox"/>	<input type="checkbox"/> <input type="checkbox"/> <input type="checkbox"/>	<input type="checkbox"/> <input type="checkbox"/>	<input type="checkbox"/> <input type="checkbox"/>	71.00#	606	88	19
	24 x 48"	RXEFA2448	<input type="checkbox"/> <input type="checkbox"/> <input type="checkbox"/>	<input type="checkbox"/> <input type="checkbox"/> <input type="checkbox"/>	<input type="checkbox"/> <input type="checkbox"/>	<input type="checkbox"/> <input type="checkbox"/>	81.00#	621	88	19
	24 x 54"	RXEFA2454	<input type="checkbox"/> <input type="checkbox"/> <input type="checkbox"/>	<input type="checkbox"/> <input type="checkbox"/> <input type="checkbox"/>	<input type="checkbox"/> <input type="checkbox"/>	<input type="checkbox"/> <input type="checkbox"/>	86.00#	637	88	27
	24 x 60"	RXEFA2460	<input type="checkbox"/> <input type="checkbox"/> <input type="checkbox"/>	<input type="checkbox"/> <input type="checkbox"/> <input type="checkbox"/>	<input type="checkbox"/> <input type="checkbox"/>	<input type="checkbox"/> <input type="checkbox"/>	91.00#	639	88	27
	24 x 66"	RXEFA2466	<input type="checkbox"/> <input type="checkbox"/> <input type="checkbox"/>	<input type="checkbox"/> <input type="checkbox"/> <input type="checkbox"/>	<input type="checkbox"/> <input type="checkbox"/>	<input type="checkbox"/> <input type="checkbox"/>	97.00#	650	88	27
	24 x 72"	RXEFA2472	<input type="checkbox"/> <input type="checkbox"/> <input type="checkbox"/>	<input type="checkbox"/> <input type="checkbox"/> <input type="checkbox"/>	<input type="checkbox"/> <input type="checkbox"/>	<input type="checkbox"/> <input type="checkbox"/>	101.00#	655	88	27
	30 x 48"	RXEFA3048	<input type="checkbox"/> <input type="checkbox"/> <input type="checkbox"/>	<input type="checkbox"/> <input type="checkbox"/> <input type="checkbox"/>	<input type="checkbox"/> <input type="checkbox"/>	<input type="checkbox"/> <input type="checkbox"/>	91.00#	649	88	27
	30 x 54"	RXEFA3054	<input type="checkbox"/> <input type="checkbox"/> <input type="checkbox"/>	<input type="checkbox"/> <input type="checkbox"/> <input type="checkbox"/>	<input type="checkbox"/> <input type="checkbox"/>	<input type="checkbox"/> <input type="checkbox"/>	97.00#	669	88	27
	30 x 60"	RXEFA3060	<input type="checkbox"/> <input type="checkbox"/> <input type="checkbox"/>	<input type="checkbox"/> <input type="checkbox"/> <input type="checkbox"/>	<input type="checkbox"/> <input type="checkbox"/>	<input type="checkbox"/> <input type="checkbox"/>	104.00#	672	88	27
	30 x 66"	RXEFA3066	<input type="checkbox"/> <input type="checkbox"/> <input type="checkbox"/>	<input type="checkbox"/> <input type="checkbox"/> <input type="checkbox"/>	<input type="checkbox"/> <input type="checkbox"/>	<input type="checkbox"/> <input type="checkbox"/>	111.00#	678	88	27
	30 x 72"	RXEFA3072	<input type="checkbox"/> <input type="checkbox"/> <input type="checkbox"/>	<input type="checkbox"/> <input type="checkbox"/> <input type="checkbox"/>	<input type="checkbox"/> <input type="checkbox"/>	<input type="checkbox"/> <input type="checkbox"/>	116.00#	683	88	27
	36 x 54"	RXEFA3654	<input type="checkbox"/> <input type="checkbox"/> <input type="checkbox"/>	<input type="checkbox"/> <input type="checkbox"/> <input type="checkbox"/>	<input type="checkbox"/> <input type="checkbox"/>	<input type="checkbox"/> <input type="checkbox"/>	109.00#	814	88	53
	36 x 60"	RXEFA3660	<input type="checkbox"/> <input type="checkbox"/> <input type="checkbox"/>	<input type="checkbox"/> <input type="checkbox"/> <input type="checkbox"/>	<input type="checkbox"/> <input type="checkbox"/>	<input type="checkbox"/> <input type="checkbox"/>	116.00#	816	88	53
	36 x 66"	RXEFA3666	<input type="checkbox"/> <input type="checkbox"/> <input type="checkbox"/>	<input type="checkbox"/> <input type="checkbox"/> <input type="checkbox"/>	<input type="checkbox"/> <input type="checkbox"/>	<input type="checkbox"/> <input type="checkbox"/>	123.00#	820	88	53
	36 x 72"	RXEFA3672	<input type="checkbox"/> <input type="checkbox"/> <input type="checkbox"/>	<input type="checkbox"/> <input type="checkbox"/> <input type="checkbox"/>	<input type="checkbox"/> <input type="checkbox"/>	<input type="checkbox"/> <input type="checkbox"/>	131.00#	827	88	53
	42 x 60"	RXEFA4260	<input type="checkbox"/> <input type="checkbox"/> <input type="checkbox"/>	<input type="checkbox"/> <input type="checkbox"/> <input type="checkbox"/>	<input type="checkbox"/> <input type="checkbox"/>	<input type="checkbox"/> <input type="checkbox"/>	129.00#	832	88	53
	42 x 66"	RXEFA4266	<input type="checkbox"/> <input type="checkbox"/> <input type="checkbox"/>	<input type="checkbox"/> <input type="checkbox"/> <input type="checkbox"/>	<input type="checkbox"/> <input type="checkbox"/>	<input type="checkbox"/> <input type="checkbox"/>	135.00#	835	88	53
	42 x 72"	RXEFA4272	<input type="checkbox"/> <input type="checkbox"/> <input type="checkbox"/>	<input type="checkbox"/> <input type="checkbox"/> <input type="checkbox"/>	<input type="checkbox"/> <input type="checkbox"/>	<input type="checkbox"/> <input type="checkbox"/>	146.00#	849	88	53
	44 x 60"	RXEFA4460	<input type="checkbox"/> <input type="checkbox"/> <input type="checkbox"/>	<input type="checkbox"/> <input type="checkbox"/> <input type="checkbox"/>	<input type="checkbox"/> <input type="checkbox"/>	<input type="checkbox"/> <input type="checkbox"/>	133.00#	953	88	53
	44 x 66"	RXEFA4466	<input type="checkbox"/> <input type="checkbox"/> <input type="checkbox"/>	<input type="checkbox"/> <input type="checkbox"/> <input type="checkbox"/>	<input type="checkbox"/> <input type="checkbox"/>	<input type="checkbox"/> <input type="checkbox"/>	145.00#	955	88	53
	44 x 72"	RXEFA4472	<input type="checkbox"/> <input type="checkbox"/> <input type="checkbox"/>	<input type="checkbox"/> <input type="checkbox"/> <input type="checkbox"/>	<input type="checkbox"/> <input type="checkbox"/>	<input type="checkbox"/> <input type="checkbox"/>	151.00#	958	88	53
	48 x 60"	RXEFA4860	<input type="checkbox"/> <input type="checkbox"/> <input type="checkbox"/>	<input type="checkbox"/> <input type="checkbox"/> <input type="checkbox"/>	<input type="checkbox"/> <input type="checkbox"/>	<input type="checkbox"/> <input type="checkbox"/>	143.00#	990	88	53
48 x 66"	RXEFA4866	<input type="checkbox"/> <input type="checkbox"/> <input type="checkbox"/>	<input type="checkbox"/> <input type="checkbox"/> <input type="checkbox"/>	<input type="checkbox"/> <input type="checkbox"/>	<input type="checkbox"/> <input type="checkbox"/>	155.00#	992	88	53	
48 x 72"	RXEFA4872	<input type="checkbox"/> <input type="checkbox"/> <input type="checkbox"/>	<input type="checkbox"/> <input type="checkbox"/> <input type="checkbox"/>	<input type="checkbox"/> <input type="checkbox"/>	<input type="checkbox"/> <input type="checkbox"/>	156.00#	994	88	53	

A **B** **C** **D** **E**

HOW TO ORDER

- Indicate the following information on order form:
1. Quantity of each item.
 2. Model number, including options. See "How To Build a Model Number".
 3. Any special service required.

Note: • The indicates that a choice is required.

- The absence of the indicates that no choice is required.
- Alpha-numeric characters in place of indicate that no other alternatives are available.

HOW TO BUILD A MODEL NUMBER

A Select basic model/edge style.

74P - 1-1/4" laminate top w/74P edge band

B Select edge color.

Refer to the **Product Color Options** page in this price list.

C Select surface finish.

Refer to the **Product Color Options** page in this price list.

D Select base finish.

Refer to the **Product Color Options** page in this price list.

E Select base option.

CCC - Casters

BCF - Casters/felt glides

BCN - Casters/nylon glides

GFT - Felt glides

GNV - Nylon glides

FINISH INFORMATION

Additional Laminate Offering

KI offers laminates beyond those offered in the standard offering. Laminates that are currently available in the program can be viewed in KI product specification tools. Requests to add laminates to the program can be submitted via the product modification request process. Please note, requests to add laminates to the program must include the laminate manufacturer's name, color/pattern number, and finish code. Edge options are limited to standard edge colors. If a matching edge is required, this will need to be requested through the product modification request process and may be subject to additional costs. Due to varying manufacturing processes and quality issues with some laminates, some requests may be denied. Extended lead times and minimum order quantities may apply on orders containing special laminates. Contact the product modification team for questions or additional information regarding special laminates and pricing.

SPECIAL SERVICES

Special Carton Marking

With specially marked information N/C

Shipping

Ships **knocked down, FOB Bonduel, WI 54107, freight excluded.** Freight class 70.

Specifications and prices are subject to change without prior notice.

Ruckus® Activity Table (Freight Excluded Pricing)

1-1/4" Top - 74P Edge



Ruckus® Activity Table (Freight Excluded Pricing)

1-1/4" Top - 74P Edge

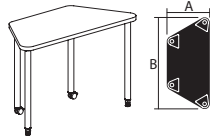
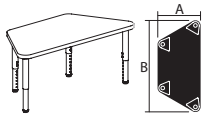
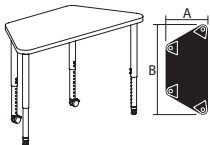
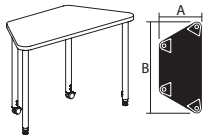
MODEL	A x B	MODEL NUMBER					Approx. Packaged Weight	Freight Excluded Pricing	Chrome Upcharge add to list price	Laminate Grade 2 add to list price
		Basic Model/Edge Style	Edge Color	Surface Finish	Base Finish	Base Option				
 <p>Fixed Height Trapezoid Table, 29" H</p> <ul style="list-style-type: none"> • Casters and glides are interchangeable • Tables are designed for maximum leg spacing • All corners of surface are rounded • Specify casters/glides to wheelbarrow 	24 x 48"	RTEAM48-74P	<input type="checkbox"/>	<input type="checkbox"/>	<input type="checkbox"/>	51.00#	\$ 500	\$ 70	\$ 19	
	30 x 60"	RTEAM60-74P	<input type="checkbox"/>	<input type="checkbox"/>	<input type="checkbox"/>	65.00#	540	70	27	
RTEAM										
 <p>Floor Height Adjustable Trapezoid Table, 12 to 19" H</p> <ul style="list-style-type: none"> • Tables are designed for maximum leg spacing • All corners of surface are rounded • Legs adjust with screws in 1" increments • Legs are factory pre-set at 19"H • Base only available in glides 	24 x 48"	RTEHM48-74P	<input type="checkbox"/>	<input type="checkbox"/>	<input type="checkbox"/>	47.00#	\$ 562	\$ 75	\$ 19	
	30 x 60"	RTEHM60-74P	<input type="checkbox"/>	<input type="checkbox"/>	<input type="checkbox"/>	61.00#	602	75	27	
RTEHM										
 <p>Sit Height Adjustable Trapezoid Table, 20 to 33" H</p> <ul style="list-style-type: none"> • Casters and glides are interchangeable • Tables are designed for maximum leg spacing • All corners of surface are rounded • Specify casters/glides to wheelbarrow • Legs adjust with screws in 1" increments • Legs are factory pre-set at 29"H 	24 x 48"	RTEEM48-74P	<input type="checkbox"/>	<input type="checkbox"/>	<input type="checkbox"/>	53.00#	\$ 565	\$ 77	\$ 19	
	30 x 60"	RTEEM60-74P	<input type="checkbox"/>	<input type="checkbox"/>	<input type="checkbox"/>	65.00#	605	77	27	
RTEEM										
 <p>Sit-Stand Height Adjustable Trapezoid Table, 29 to 42" H</p> <ul style="list-style-type: none"> • Casters and glides are interchangeable • Tables are designed for maximum leg spacing • All corners of surface are rounded • Specify casters/glides to wheelbarrow • Legs adjust with screws in 1" increments • Legs are factory pre-set at 29"H 	24 x 48"	RTEFM48-74P	<input type="checkbox"/>	<input type="checkbox"/>	<input type="checkbox"/>	55.00#	\$ 585	\$ 88	\$ 19	
	30 x 60"	RTEFM60-74P	<input type="checkbox"/>	<input type="checkbox"/>	<input type="checkbox"/>	70.00#	625	88	27	
RTEFM										

A **B** **C** **D** **E**

HOW TO ORDER

- Indicate the following information on order form:
1. Quantity of each item.
 2. Model number, including options. See "How To Build a Model Number".
 3. Any special service required.

Note: • The indicates that a choice is required.
 • The absence of the indicates that no choice is required.
 • Alpha-numeric characters in place of indicate that no other alternatives are available.

HOW TO BUILD A MODEL NUMBER

- A** Select basic model/edge style.
74P - 1-1/4" laminate top w/74P edge band
- B** Select edge color.
 Refer to the **Product Color Options** page in this price list.
- C** Select surface finish.
 Refer to the **Product Color Options** page in this price list.
- D** Select base finish.
 Refer to the **Product Color Options** page in this price list.
- E** Select base option.
CCC - Casters
BCF - Casters/felt glides
BCN - Casters/nylon glides
GFT - Felt glides
GNV - Nylon glides
 Base options for Floor Height Adjustable are

ONLY Felt glides - GFT and Nylon glides - GNV

FINISH INFORMATION

Additional Laminate Offering
 KI offers laminates beyond those offered in the standard offering. Laminates that are currently available in the program can be viewed in KI product specification tools. Requests to add laminates to the program can be submitted via the product modification request process. Please note, requests to add laminates to the program must include the laminate manufacturer's name, color/pattern number, and finish code. Edge options are limited to standard edge colors. If a matching edge is required, this will need to be requested through the product modification request process and may be subject to additional costs. Due to varying manufacturing processes and quality issues with some laminates, some requests may be denied. Extended lead times and minimum order quantities may apply on orders containing special laminates. Contact the product modification team for questions or additional information regarding special laminates and pricing.

SPECIAL SERVICES

Special Carton Marking

With specially marked information N/C

Shipping
 Ships **knocked down, FOB Bonduel, WI 54107, freight excluded.** Freight class 70.

Specifications and prices are subject to change without prior notice.

Ruckus® Activity Table (Freight Excluded Pricing)

1-1/4" Top - 74P Edge



Ruckus® Activity Table (Freight Excluded Pricing)

1-1/4" Top - 74P Edge

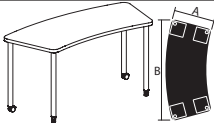
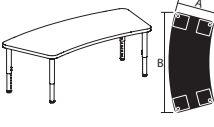
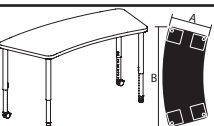
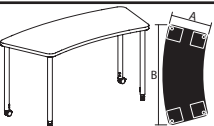
MODEL	A x B	MODEL NUMBER					Approx. Packaged Weight	Freight Excluded Pricing	Chrome Upcharge add to list price	Laminate Grade 2 add to list price
		Basic Model/Edge Style	Edge Color	Surface Finish	Base Finish	Base Option				
 <p>Fixed Height Arc Table, 29" H</p> <ul style="list-style-type: none"> • Casters and glides are interchangeable • Tables are designed for maximum leg spacing • All corners of surface are rounded • Specify casters/glides to wheelbarrow 	24 x 59"	RTEAR24-74P	<input type="checkbox"/>	<input type="checkbox"/>	<input type="checkbox"/>	<input type="checkbox"/>	79.00#	\$ 635	\$ 88	\$ 27
RTEAR										
 <p>Floor Height Adjustable Arc Table, 12 to 19" H</p> <ul style="list-style-type: none"> • Tables are designed for maximum leg spacing • All corners of surface are rounded • Legs adjust with screws in 1" increments • Legs are factory pre-set at 19"H • Base only available in glides 	24 x 59"	RTEHR24-74P	<input type="checkbox"/>	<input type="checkbox"/>	<input type="checkbox"/>	<input type="checkbox"/>	76.00#	\$ 713	\$ 93	\$ 27
RTEHR										
 <p>Sit Height Adjustable Arc Table, 20 to 33" H</p> <ul style="list-style-type: none"> • Casters and glides are interchangeable • Tables are designed for maximum leg spacing • All corners of surface are rounded • Specify casters/glides to wheelbarrow • Legs adjust with screws in 1" increments • Legs are factory pre-set at 29"H 	24 x 59"	RTEER24-74P	<input type="checkbox"/>	<input type="checkbox"/>	<input type="checkbox"/>	<input type="checkbox"/>	81.00#	\$ 716	\$ 97	\$ 27
RTEER										
 <p>Sit-Stand Height Adjustable Arc Table, 29 to 42" H</p> <ul style="list-style-type: none"> • Casters and glides are interchangeable • Tables are designed for maximum leg spacing • All corners of surface are rounded • Specify casters/glides to wheelbarrow • Legs adjust with screws in 1" increments • Legs are factory pre-set at 29"H 	24 x 59"	RTEFR24-74P	<input type="checkbox"/>	<input type="checkbox"/>	<input type="checkbox"/>	<input type="checkbox"/>	85.00#	\$ 741	\$ 110	\$ 27
RTEFR										

A **B** **C** **D** **E**

HOW TO ORDER

- Indicate the following information on order form:
1. Quantity of each item.
 2. Model number, including options. See "How To Build a Model Number".
 3. Any special service required.

Note: • The indicates that a choice is required.

- The absence of the indicates that no choice is required.
- Alpha-numeric characters in place of indicate that no other alternatives are available.

HOW TO BUILD A MODEL NUMBER

A Select basic model/edge style.
74P - 1-1/4" laminate top w/74P edge band

B Select edge color.
 Refer to the **Product Color Options** page in this price list.

C Select surface finish.
 Refer to the **Product Color Options** page in this price list.

D Select base finish.
 Refer to the **Product Color Options** page in this price list.

E Select base option.
CCC - Casters
BCF - Casters/felt glides
BCN - Casters/nylon glides
GFT - Felt glides
GNV - Nylon glides
 Base options for Floor Height Adjustable are

ONLY Felt glides - GFT and Nylon glides - GNV

FINISH INFORMATION

Additional Laminate Offering

KI offers laminates beyond those offered in the standard offering. Laminates that are currently available in the program can be viewed in KI product specification tools. Requests to add laminates to the program can be submitted via the product modification request process. Please note, requests to add laminates to the program must include the laminate manufacturer's name, color/pattern number, and finish code. Edge options are limited to standard edge colors. If a matching edge is required, this will need to be requested through the product modification request process and may be subject to additional costs. Due to varying manufacturing processes and quality issues with some laminates, some requests may be denied. Extended lead times and minimum order quantities may apply on orders containing special laminates. Contact the product modification team for questions or additional information regarding special laminates and pricing.

SPECIAL SERVICES

Special Carton Marking

With specially marked information N/C

Shipping

Ships **knocked down**, FOB Bonduel, WI 54107, **freight excluded**. Freight class 70.

Specifications and prices are subject to change without prior notice.

Ruckus® Activity Table (Freight Excluded Pricing)

1-1/4" Top - 74P Edge



Ruckus® Activity Table (Freight Excluded Pricing)

1-1/4" Top - 74P Edge

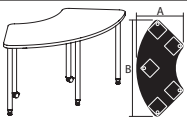
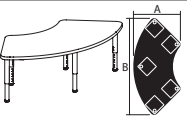
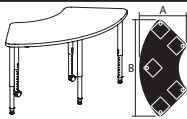
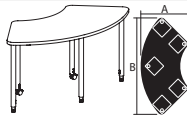
MODEL	A x B	MODEL NUMBER					Approx. Packaged Weight	Freight Excluded Pricing	Chrome Upcharge add to list price	Laminate Grade 2 add to list price
		Basic Model/Edge Style	Edge Color	Surface Finish	Base Finish	Base Option				
 <p>Fixed Height Quarter Round Table, 29" H • Casters and glides are interchangeable • Tables are designed for maximum leg spacing • All corners of surface are rounded • Specify casters/glides to wheelbarrow</p>	24 x 65"	RTEAX24-74P	<input type="checkbox"/>	<input type="checkbox"/>	<input type="checkbox"/>	<input type="checkbox"/>	76.00#	\$ 700	\$ 70	\$ 27
RTEAX										
 <p>Floor Height Adjustable Quarter Round Table, 12 to 19" H • Tables are designed for maximum leg spacing • All corners of surface are rounded • Legs adjust with screws in 1" increments • Legs are factory pre-set at 19"H • Base only available in glides</p>	24 x 65"	RTEHX24-74P	<input type="checkbox"/>	<input type="checkbox"/>	<input type="checkbox"/>	<input type="checkbox"/>	71.00#	\$ 762	\$ 75	\$ 27
RTEHX										
 <p>Sit Height Adjustable Quarter Round Table, 20 to 33" H • Casters and glides are interchangeable • Tables are designed for maximum leg spacing • All corners of surface are rounded • Specify casters/glides to wheelbarrow • Legs adjust with screws in 1" increments • Legs are factory pre-set at 29"H</p>	24 x 65"	RTEEX24-74P	<input type="checkbox"/>	<input type="checkbox"/>	<input type="checkbox"/>	<input type="checkbox"/>	78.00#	\$ 765	\$ 77	\$ 27
RTEEX										
 <p>Sit-Stand Height Adjustable Quarter Round Table, 29 to 42" H • Casters and glides are interchangeable • Tables are designed for maximum leg spacing • All corners of surface are rounded • Specify casters/glides to wheelbarrow • Legs adjust with screws in 1" increments • Legs are factory pre-set at 29"H</p>	24 x 65"	RTEFX24-74P	<input type="checkbox"/>	<input type="checkbox"/>	<input type="checkbox"/>	<input type="checkbox"/>	84.00#	\$ 785	\$ 88	\$ 27
RTEFX										

A **B** **C** **D** **E**

HOW TO ORDER

- Indicate the following information on order form:
- Quantity of each item.
 - Model number, including options. See "How To Build a Model Number".
 - Any special service required.

Note: • The indicates that a choice is required.
 • The absence of the indicates that no choice is required.
 • Alpha-numeric characters in place of indicate that no other alternatives are available.

HOW TO BUILD A MODEL NUMBER

GNY - Nylon glides

- A** Select basic model/edge style.
74P - 1-1/4" laminate top w/74P edge band
- B** Select edge color.
 Refer to the **Product Color Options** page in this price list.
- C** Select surface finish.
 Refer to the **Product Color Options** page in this price list.
- D** Select base finish.
 Refer to the **Product Color Options** page in this price list.
- E** Select base option.
 Base options for Floor Height Adjustable are ONLY Felt glides - GFT and Nylon glides - GNY
CCC - Casters
BCF - Casters/felt glides
BCN - Casters/nylon glides
GFT - Felt glides

FINISH INFORMATION

Additional Laminate Offering

KI offers laminates beyond those offered in the standard offering. Laminates that are currently available in the program can be viewed in KI product specification tools. Requests to add laminates to the program can be submitted via the product modification request process. Please note, requests to add laminates to the program must include the laminate manufacturer's name, color/pattern number, and finish code. Edge options are limited to standard edge colors. If a matching edge is required, this will need to be requested through the product modification request process and may be subject to additional costs. Due to varying manufacturing processes and quality issues with some laminates, some requests may be denied. Extended lead times and minimum order quantities may apply on orders containing special laminates. Contact the product modification team for questions or additional information regarding special laminates and pricing.

SPECIAL SERVICES

Special Carton Marking

With specially marked information N/C

Shipping

Ships **knocked down**, FOB Bonduel, WI 54107, **freight excluded**. Freight class 70.

Specifications and prices are subject to change without prior notice.

Ruckus® Activity Table (Freight Excluded Pricing)

1-1/4" Top - 74P Edge



Ruckus® Activity Table (Freight Excluded Pricing)

1-1/4" Top - 74P Edge

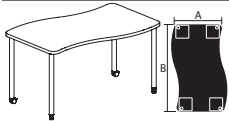
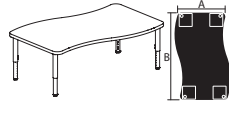
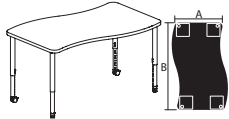
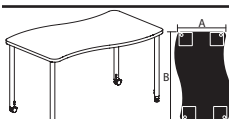
MODEL	A x B	MODEL NUMBER					Approx. Packaged Weight	Freight Excluded Pricing	Chrome Upcharge add to list price	Laminate Grade 2 add to list price
		Basic Model/Edge Style	Edge Color	Surface Finish	Base Finish	Base Option				
 RTEAW Fixed Height Wave Table, 29" H • Casters and glides are interchangeable • Tables are designed for maximum leg spacing • All corners of surface are rounded • Specify casters/glides to wheelbarrow • Pairs well with Yin Yang	30 x 54"	RTEAW3054-74P	<input type="checkbox"/>	<input type="checkbox"/>	<input type="checkbox"/>	<input type="checkbox"/>	89.00#	\$ 650	\$ 70	\$ 27
	30 x 60"	RTEAW3060-74P	<input type="checkbox"/>	<input type="checkbox"/>	<input type="checkbox"/>	<input type="checkbox"/>	96.00#	670	70	27
 RTEHW Floor Height Adjustable Wave Table, 12 to 19" H • Tables are designed for maximum leg spacing • All corners of surface are rounded • Legs adjust with screws in 1" increments • Legs are factory pre-set at 19"H • Base only available in glides • Pairs well with Yin Yang	30 x 54"	RTEHW3054-74P	<input type="checkbox"/>	<input type="checkbox"/>	<input type="checkbox"/>	<input type="checkbox"/>	85.00#	\$ 712	\$ 75	\$ 27
	30 x 60"	RTEHW3060-74P	<input type="checkbox"/>	<input type="checkbox"/>	<input type="checkbox"/>	<input type="checkbox"/>	90.00#	732	75	27
 RTEEW Sit Height Adjustable Wave Table, 20 to 33" H • Casters and glides are interchangeable • Tables are designed for maximum leg spacing • All corners of surface are rounded • Specify casters/glides to wheelbarrow • Legs adjust with screws in 1" increments • Legs are factory pre-set at 29"H • Pairs well with Yin Yang	30 x 54"	RTEEW3054-74P	<input type="checkbox"/>	<input type="checkbox"/>	<input type="checkbox"/>	<input type="checkbox"/>	89.00#	\$ 715	\$ 77	\$ 27
	30 x 60"	RTEEW3060-74P	<input type="checkbox"/>	<input type="checkbox"/>	<input type="checkbox"/>	<input type="checkbox"/>	97.00#	735	77	27
 RTEFW Sit-Stand Height Adjustable Wave Table, 29 to 42" H • Casters and glides are interchangeable • Tables are designed for maximum leg spacing • All corners of surface are rounded • Specify casters/glides to wheelbarrow • Legs adjust with screws in 1" increments • Legs are factory pre-set at 29"H • Pairs well with Yin Yang	30 x 54"	RTEFW3054-74P	<input type="checkbox"/>	<input type="checkbox"/>	<input type="checkbox"/>	<input type="checkbox"/>	95.00#	\$ 735	\$ 88	\$ 27
	30 x 60"	RTEFW3060-74P	<input type="checkbox"/>	<input type="checkbox"/>	<input type="checkbox"/>	<input type="checkbox"/>	102.00#	755	88	27

A **B** **C** **D** **E**

HOW TO ORDER

- Indicate the following information on order form:
- Quantity of each item.
 - Model number, including options. See "How To Build a Model Number".
 - Any special service required.

Note: • The indicates that a choice is required.

- The absence of the indicates that no choice is required.
- Alpha-numeric characters in place of indicate that no other alternatives are available.

HOW TO BUILD A MODEL NUMBER

A Select basic model/edge style.
74P - 1-1/4" laminate top w/74P edge band

B Select edge color.
 Refer to the **Product Color Options** page in this price list.

C Select surface finish.
 Refer to the **Product Color Options** page in this price list.

D Select base finish.
 Refer to the **Product Color Options** page in this price list.

E Select base option.
CCC - Casters
BCF - Casters/felt glides
BCN - Casters/nylon glides
GFT - Felt glides
GNV - Nylon glides
 Base options for Floor Height Adjustable are

ONLY Felt glides - GFT and Nylon glides - GNV

FINISH INFORMATION

Additional Laminate Offering

KI offers laminates beyond those offered in the standard offering. Laminates that are currently available in the program can be viewed in KI product specification tools. Requests to add laminates to the program can be submitted via the product modification request process. Please note, requests to add laminates to the program must include the laminate manufacturer's name, color/pattern number, and finish code. Edge options are limited to standard edge colors. If a matching edge is required, this will need to be requested through the product modification request process and may be subject to additional costs. Due to varying manufacturing processes and quality issues with some laminates, some requests may be denied. Extended lead times and minimum order quantities may apply on orders containing special laminates. Contact the product modification team for questions or additional information regarding special laminates and pricing.

SPECIAL SERVICES

Special Carton Marking

With specially marked information N/C

Shipping

Ships **knocked down**, FOB **Bonduel, WI 54107**, **freight excluded**. Freight class 70.

Specifications and prices are subject to change without prior notice.

Ruckus® Activity Table (Freight Excluded Pricing)

1-1/4" Top - 74P Edge



Ruckus® Activity Table (Freight Excluded Pricing)

1-1/4" Top - 74P Edge

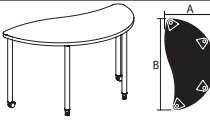
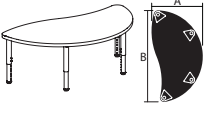
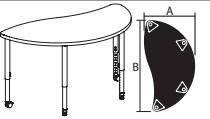
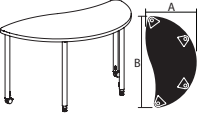
MODEL	A x B	MODEL NUMBER					Approx. Packaged Weight	Freight Excluded Pricing	Chrome Upcharge add to list price	Laminate Grade 2 add to list price
		Basic Model/Edge Style	Edge Color	Surface Finish	Base Finish	Base Option				
 RTEAO Fixed Height Yin Yang Table, 29" H • Casters and glides are interchangeable • Tables are designed for maximum leg spacing • All corners of surface are rounded • Specify casters/glides to wheelbarrow • Pairs well with like size Wave shaped table	30 x 54"	RTEAO54-74P	<input type="checkbox"/>	<input type="checkbox"/>	<input type="checkbox"/>	<input type="checkbox"/>	63.00#	\$ 545	\$ 70	\$ 53
	30 x 60"	RTEAO60-74P	<input type="checkbox"/>	<input type="checkbox"/>	<input type="checkbox"/>	<input type="checkbox"/>	73.00#	590	70	53
 RTEHO Floor Height Adjustable Yin Yang Table, 12 to 19" H • Tables are designed for maximum leg spacing • All corners of surface are rounded • Legs adjust with screws in 1" increments • Legs are factory pre-set at 19"H • Base only available in glides • Pairs well with like size Wave shaped table	30 x 54"	RTEHO54-74P	<input type="checkbox"/>	<input type="checkbox"/>	<input type="checkbox"/>	<input type="checkbox"/>	57.00#	\$ 607	\$ 75	\$ 53
	30 x 60"	RTEHO60-74P	<input type="checkbox"/>	<input type="checkbox"/>	<input type="checkbox"/>	<input type="checkbox"/>	74.00#	652	75	53
 RTEEO Sit Height Adjustable Yin Yang Table, 20 to 33" H • Casters and glides are interchangeable • Tables are designed for maximum leg spacing • All corners of surface are rounded • Specify casters/glides to wheelbarrow • Legs adjust with screws in 1" increments • Legs are factory pre-set at 29"H • Pairs well with like size Wave shaped table	30 x 54"	RTEEO54-74P	<input type="checkbox"/>	<input type="checkbox"/>	<input type="checkbox"/>	<input type="checkbox"/>	65.00#	\$ 610	\$ 77	\$ 53
	30 x 60"	RTEEO60-74P	<input type="checkbox"/>	<input type="checkbox"/>	<input type="checkbox"/>	<input type="checkbox"/>	73.00#	655	77	53
 RTEFO Sit-Stand Height Adjustable Yin Yang Table, 29 to 42" H • Casters and glides are interchangeable • Tables are designed for maximum leg spacing • All corners of surface are rounded • Specify casters/glides to wheelbarrow • Legs adjust with screws in 1" increments • Legs are factory pre-set at 29"H • Pairs well with like size Wave shaped table	30 x 54"	RTEFO54-74P	<input type="checkbox"/>	<input type="checkbox"/>	<input type="checkbox"/>	<input type="checkbox"/>	69.00#	\$ 630	\$ 88	\$ 53
	30 x 60"	RTEFO60-74P	<input type="checkbox"/>	<input type="checkbox"/>	<input type="checkbox"/>	<input type="checkbox"/>	74.00#	675	88	53

A B C D E

HOW TO ORDER

- Indicate the following information on order form:
- Quantity of each item.
 - Model number, including options. See "How To Build a Model Number".
 - Any special service required.

Note: • The indicates that a choice is required.
 • The absence of the indicates that no choice is required.
 • Alpha-numeric characters in place of indicate that no other alternatives are available.

HOW TO BUILD A MODEL NUMBER

- ONLY Felt glides - GFT and Nylon glides - GNY
- A** Select basic model/edge style.
 74P - 1-1/4" laminate top w/74P edge band
 - B** Select edge color.
 Refer to the **Product Color Options** page in this price list.
 - C** Select surface finish.
 Refer to the **Product Color Options** page in this price list.
 - D** Select base finish.
 Refer to the **Product Color Options** page in this price list.
 - E** Select base option.
 CCC - Casters
 BCF - Casters/felt glides
 BCN - Casters/nylon glides
 GFT - Felt glides
 GNY - Nylon glides
 Base options for Floor Height Adjustable are

FINISH INFORMATION

Additional Laminate Offering
 KI offers laminates beyond those offered in the standard offering. Laminates that are currently available in the program can be viewed in KI product specification tools. Requests to add laminates to the program can be submitted via the product modification request process. Please note, requests to add laminates to the program must include the laminate manufacturer's name, color/pattern number, and finish code. Edge options are limited to standard edge colors. If a matching edge is required, this will need to be requested through the product modification request process and may be subject to additional costs. Due to varying manufacturing processes and quality issues with some laminates, some requests may be denied. Extended lead times and minimum order quantities may apply on orders containing special laminates. Contact the product modification team for questions or additional information regarding special laminates and pricing.

SPECIAL SERVICES

Special Carton Marking
 With specially marked information N/C

Shipping
 Ships **knocked down, FOB Bonduel, WI 54107, freight excluded.** Freight class 70.
 Specifications and prices are subject to change without prior notice.

Ruckus® Activity Table (Freight Excluded Pricing)

1-1/4" Top - 74P Edge



Ruckus® Activity Table (Freight Excluded Pricing)

1-1/4" Top - 74P Edge

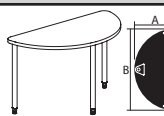
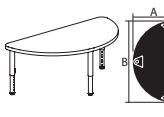
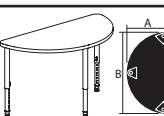
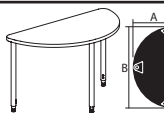
MODEL	A x B	MODEL NUMBER					Approx. Packaged Weight	Freight Excluded Pricing	Chrome Upcharge add to list price	Laminate Grade 2 add to list price
		Basic Model/Edge Style	Edge Color	Surface Finish	Base Finish	Base Option				
 RTEAQ Fixed Height Half Round Table, 29" H • Casters and glides are interchangeable • Tables are designed for maximum leg spacing • All corners of surface are rounded • Specify casters/glides to wheelbarrow • 48" tables have 3 legs; 60" tables have 4 legs	24 x 48"	RTEAQ48-74P	<input type="checkbox"/>	<input type="checkbox"/>	<input type="checkbox"/>	<input type="checkbox"/>	50.00#	\$ 445	\$ 51	\$ 19
	30 x 60"	RTEAQ60-74P	<input type="checkbox"/>	<input type="checkbox"/>	<input type="checkbox"/>	<input type="checkbox"/>	72.00#	585	70	27
 RTEHQ Floor Height Adjustable Half Round Table, 12 to 19" H • Tables are designed for maximum leg spacing • All corners of surface are rounded • Legs adjust with screws in 1" increments • Legs are factory pre-set at 19"H • Base only available in glides • 48" tables have 3 legs; 60" tables have 4 legs	24 x 48"	RTEHQ48-74P	<input type="checkbox"/>	<input type="checkbox"/>	<input type="checkbox"/>	<input type="checkbox"/>	47.00#	\$ 492	\$ 54	\$ 19
	30 x 60"	RTEHQ60-74P	<input type="checkbox"/>	<input type="checkbox"/>	<input type="checkbox"/>	<input type="checkbox"/>	68.00#	647	75	27
 RTEEQ Sit Height Adjustable Half Round Table, 20 to 33" H • Casters and glides are interchangeable • Tables are designed for maximum leg spacing • All corners of surface are rounded • Specify casters/glides to wheelbarrow • Legs adjust with screws in 1" increments • Legs are factory pre-set at 29"H • 48" tables have 3 legs; 60" tables have 4 legs	24 x 48"	RTEEQ48-74P	<input type="checkbox"/>	<input type="checkbox"/>	<input type="checkbox"/>	<input type="checkbox"/>	51.00#	\$ 494	\$ 56	\$ 19
	30 x 60"	RTEEQ60-74P	<input type="checkbox"/>	<input type="checkbox"/>	<input type="checkbox"/>	<input type="checkbox"/>	81.00#	650	77	27
 RTEFQ Sit-Stand Height Adjustable Half Round Table, 29 to 42" H • Casters and glides are interchangeable • Tables are designed for maximum leg spacing • All corners of surface are rounded • Specify casters/glides to wheelbarrow • Legs adjust with screws in 1" increments • Legs are factory pre-set at 29"H • 48" tables have 3 legs; 60" tables have 4 legs	24 x 48"	RTEFQ48-74P	<input type="checkbox"/>	<input type="checkbox"/>	<input type="checkbox"/>	<input type="checkbox"/>	55.00#	\$ 509	\$ 65	\$ 19
	30 x 60"	RTEFQ60-74P	<input type="checkbox"/>	<input type="checkbox"/>	<input type="checkbox"/>	<input type="checkbox"/>	78.00#	670	88	27

A B C D E

HOW TO ORDER

- Indicate the following information on order form:
- Quantity of each item.
 - Model number, including options. See "How To Build a Model Number".
 - Any special service required.

Note: • The indicates that a choice is required.
 • The absence of the indicates that no choice is required.
 • Alpha-numeric characters in place of indicate that no other alternatives are available.

HOW TO BUILD A MODEL NUMBER

- A** Select basic model/edge style.
74P - 1-1/4" laminate top w/74P edge band
- B** Select edge color.
 Refer to the **Product Color Options** page in this price list.
- C** Select surface finish.
 Refer to the **Product Color Options** page in this price list.
- D** Select base finish.
 Refer to the **Product Color Options** page in this price list.
- E** Select base option.
BCF - Casters/felt glides
BCN - Casters/nylon glides
GFT - Felt glides
GNY - Nylon glides
CCC - Casters
 Base options for Floor Height Adjustable and

48" half round tables are ONLY Felt glides - GFT and Nylon glides - GNY

FINISH INFORMATION

Additional Laminate Offering
 KI offers laminates beyond those offered in the standard offering. Laminates that are currently available in the program can be viewed in KI product specification tools. Requests to add laminates to the program can be submitted via the product modification request process. Please note, requests to add laminates to the program must include the laminate manufacturer's name, color/pattern number, and finish code. Edge options are limited to standard edge colors. If a matching edge is required, this will need to be requested through the product modification request process and may be subject to additional costs. Due to varying manufacturing processes and quality issues with some laminates, some requests may be denied. Extended lead times and minimum order quantities may apply on orders containing special laminates. Contact the product modification team for questions or additional information regarding special laminates and pricing.

SPECIAL SERVICES

Special Carton Marking
 With specially marked information N/C

Shipping
 Ships **knocked down, FOB Bonduel, WI 54107, freight excluded.** Freight class 70.

Specifications and prices are subject to change without prior notice.

Ruckus® Activity Table (Freight Excluded Pricing)

1-1/4" Top - 74P Edge



Ruckus® Activity Table (Freight Excluded Pricing)

1-1/4" Top - 74P Edge

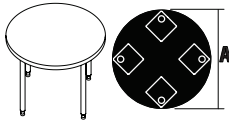
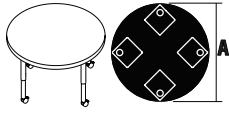
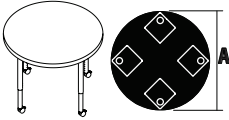
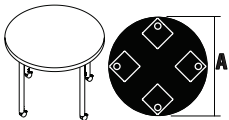
MODEL	A	MODEL NUMBER					Approx. Packaged Weight	Freight Excluded Pricing	Chrome Upcharge add to list price	Laminate Grade 2 add to list price
		Basic Model/Edge Style	Edge Color	Surface Finish	Base Finish	Base Option				
 <p>Fixed Height Round Table, 29" H</p> <ul style="list-style-type: none"> • Casters and glides are interchangeable • Tables are designed for maximum leg spacing • Specify casters/glides to wheelbarrow 	36"	RTEAB36	<input type="checkbox"/>	<input type="checkbox"/>	<input type="checkbox"/>	<input type="checkbox"/>	69.00#	\$ 590	\$ 70	\$ 37
	42"	RTEAB42	<input type="checkbox"/>	<input type="checkbox"/>	<input type="checkbox"/>	<input type="checkbox"/>	82.00#	664	70	37
	48"	RTEAB48	<input type="checkbox"/>	<input type="checkbox"/>	<input type="checkbox"/>	<input type="checkbox"/>	97.00#	713	70	37
	60"	RTEAB60	<input type="checkbox"/>	<input type="checkbox"/>	<input type="checkbox"/>	<input type="checkbox"/>	132.00#	831	70	53
RTEAB										
 <p>Floor Height Adjustable Round Table, 12 to 19" H</p> <ul style="list-style-type: none"> • Tables are designed for maximum leg spacing • Base only available in glides • Legs adjust with screws in 1" increments • Legs are factory pre-set at 19"H 	36"	RTEHB36	<input type="checkbox"/>	<input type="checkbox"/>	<input type="checkbox"/>	<input type="checkbox"/>	66.50#	\$ 619	\$ 75	\$ 37
	42"	RTEHB42	<input type="checkbox"/>	<input type="checkbox"/>	<input type="checkbox"/>	<input type="checkbox"/>	79.50#	689	75	37
	48"	RTEHB48	<input type="checkbox"/>	<input type="checkbox"/>	<input type="checkbox"/>	<input type="checkbox"/>	94.50#	737	75	37
	60"	RTEHB60	<input type="checkbox"/>	<input type="checkbox"/>	<input type="checkbox"/>	<input type="checkbox"/>	129.50#	847	75	53
RTEHB										
 <p>Sit Height Adjustable Round Table, 20 to 33" H</p> <ul style="list-style-type: none"> • Casters and glides are interchangeable • Tables are designed for maximum leg spacing • Specify casters/glides to wheelbarrow • Legs adjust with screws in 1" increments • Legs are factory pre-set at 29"H 	36"	RTEEB36	<input type="checkbox"/>	<input type="checkbox"/>	<input type="checkbox"/>	<input type="checkbox"/>	71.00#	\$ 658	\$ 77	\$ 37
	42"	RTEEB42	<input type="checkbox"/>	<input type="checkbox"/>	<input type="checkbox"/>	<input type="checkbox"/>	84.00#	732	77	37
	48"	RTEEB48	<input type="checkbox"/>	<input type="checkbox"/>	<input type="checkbox"/>	<input type="checkbox"/>	99.00#	783	77	37
	60"	RTEEB60	<input type="checkbox"/>	<input type="checkbox"/>	<input type="checkbox"/>	<input type="checkbox"/>	134.00#	900	77	53
RTEEB										
 <p>Sit-Stand Height Adjustable Round Table, 29 to 42" H</p> <ul style="list-style-type: none"> • Casters and glides are interchangeable • Tables are designed for maximum leg spacing • Specify casters/glides to wheelbarrow • Legs adjust with screws in 1" increments • Legs are factory pre-set at 29"H 	36"	RTEFB36	<input type="checkbox"/>	<input type="checkbox"/>	<input type="checkbox"/>	<input type="checkbox"/>	75.00#	\$ 675	\$ 88	\$ 37
	42"	RTEFB42	<input type="checkbox"/>	<input type="checkbox"/>	<input type="checkbox"/>	<input type="checkbox"/>	88.00#	750	88	37
	48"	RTEFB48	<input type="checkbox"/>	<input type="checkbox"/>	<input type="checkbox"/>	<input type="checkbox"/>	103.00#	798	88	37
	60"	RTEFB60	<input type="checkbox"/>	<input type="checkbox"/>	<input type="checkbox"/>	<input type="checkbox"/>	138.00#	917	88	53
RTEFB										

A B C D E

HOW TO ORDER

- Indicate the following information on order form:
1. Quantity of each item.
 2. Model number, including options. See "How To Build a Model Number".
 3. Any special service required.

Note: • The indicates that a choice is required.

- The absence of the indicates that no choice is required.
- Alpha-numeric characters in place of indicate that no other alternatives are available.

HOW TO BUILD A MODEL NUMBER

Felt glides - GFT and Nylon glides - GNY

- A** Select basic model/edge style.
74P - 1-1/4" laminate top w/74P edge band
- B** Select edge color.
 Refer to the **Product Color Options** page in this price list.
- C** Select surface finish.
 Refer to the **Product Color Options** page in this price list.
- D** Select base finish.
 Refer to the **Product Color Options** page in this price list.
- E** Select base option.
- CCC** - Casters
 - BCF** - Casters/felt glides
 - BCN** - Casters/nylon glides
 - GFT** - Felt glides
 - GNY** - Nylon glides
- Base options for Floor Activity Height are ONLY

FINISH INFORMATION

Additional Laminate Offering

KI offers laminates beyond those offered in the standard offering. Laminates that are currently available in the program can be viewed in KI product specification tools. Requests to add laminates to the program can be submitted via the product modification request process. Please note, requests to add laminates to the program must include the laminate manufacturer's name, color/pattern number, and finish code. Edge options are limited to standard edge colors. If a matching edge is required, this will need to be requested through the product modification request process and may be subject to additional costs. Due to varying manufacturing processes and quality issues with some laminates, some requests may be denied. Extended lead times and minimum order quantities may apply on orders containing special laminates. Contact the product modification team for questions or additional information regarding special laminates and pricing.

SPECIAL SERVICES

Special Carton Marking

With specially marked information N/C

Shipping

Ships **knocked down, FOB Bonduel, WI 54107, freight excluded.** Freight class 70.

Specifications and prices are subject to change without prior notice.

Ruckus® Activity Table (Freight Excluded Pricing)

1-1/4" Top - 74P Edge



Ruckus® Activity Table (Freight Excluded Pricing)

1-1/4" Top - 74P Edge

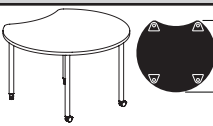
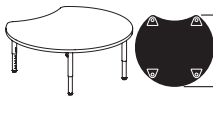
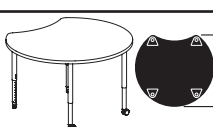
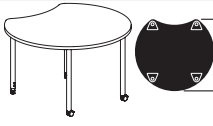
MODEL	A	MODEL NUMBER					Approx. Packaged Weight	Freight Excluded Pricing	Chrome Upcharge add to list price	Laminate Grade 2 add to list price
		Basic Model/Edge Style	Edge Color	Surface Finish	Base Finish	Base Option				
 <p>Fixed Height Crescent Table, 29" H</p> <ul style="list-style-type: none"> • Casters and glides are interchangeable • Tables are designed for maximum leg spacing • All corners of surface are rounded • Specify casters/glides to wheelbarrow 	48"	RTEAT48-74P	<input type="checkbox"/>	<input type="checkbox"/>	<input type="checkbox"/>	<input type="checkbox"/>	79.00#	\$ 600	\$ 70	\$ 37
RTEAT										
 <p>Floor Height Adjustable Crescent Table, 12 to 19" H</p> <ul style="list-style-type: none"> • Tables are designed for maximum leg spacing • All corners of surface are rounded • Legs adjust with screws in 1" increments • Legs are factory pre-set at 19"H • Base only available in glides 	48"	RTEHT48-74P	<input type="checkbox"/>	<input type="checkbox"/>	<input type="checkbox"/>	<input type="checkbox"/>	76.00#	\$ 662	\$ 75	\$ 37
RTEHT										
 <p>Sit Height Adjustable Crescent Table, 20 to 33" H</p> <ul style="list-style-type: none"> • Casters and glides are interchangeable • Tables are designed for maximum leg spacing • All corners of surface are rounded • Specify casters/glides to wheelbarrow • Legs adjust with screws in 1" increments • Legs are factory pre-set at 29"H 	48"	RTEET48-74P	<input type="checkbox"/>	<input type="checkbox"/>	<input type="checkbox"/>	<input type="checkbox"/>	81.00#	\$ 665	\$ 77	\$ 37
RTEET										
 <p>Sit-Stand Height Adjustable Crescent Table, 29 to 42" H</p> <ul style="list-style-type: none"> • Casters and glides are interchangeable • Tables are designed for maximum leg spacing • All corners of surface are rounded • Specify casters/glides to wheelbarrow • Legs adjust with screws in 1" increments • Legs are factory pre-set at 29"H 	48"	RTEFT48-74P	<input type="checkbox"/>	<input type="checkbox"/>	<input type="checkbox"/>	<input type="checkbox"/>	86.00#	\$ 685	\$ 88	\$ 37
RTEFT										

A B C D E

HOW TO ORDER

- Indicate the following information on order form:
1. Quantity of each item.
 2. Model number, including options. See "How To Build a Model Number".
 3. Any special service required.

Note: • The indicates that a choice is required.

- The absence of the indicates that no choice is required.
- Alpha-numeric characters in place of indicate that no other alternatives are available.

HOW TO BUILD A MODEL NUMBER

A Select basic model/edge style.
74P - 1-1/4" laminate top w/74P edge band

B Select edge color.
 Refer to the **Product Color Options** page in this price list.

C Select surface finish.
 Refer to the **Product Color Options** page in this price list.

D Select base finish.
 Refer to the **Product Color Options** page in this price list.

E Select base option.
CCC - Casters
BCF - Casters/felt glides
BCN - Casters/nylon glides
GFT - Felt glides
GNV - Nylon glides
 Base options for Floor Height Adjustable are

ONLY Felt glides - GFT and Nylon glides - GNV

FINISH INFORMATION

Additional Laminate Offering

KI offers laminates beyond those offered in the standard offering. Laminates that are currently available in the program can be viewed in KI product specification tools. Requests to add laminates to the program can be submitted via the product modification request process. Please note, requests to add laminates to the program must include the laminate manufacturer's name, color/pattern number, and finish code. Edge options are limited to standard edge colors. If a matching edge is required, this will need to be requested through the product modification request process and may be subject to additional costs. Due to varying manufacturing processes and quality issues with some laminates, some requests may be denied. Extended lead times and minimum order quantities may apply on orders containing special laminates. Contact the product modification team for questions or additional information regarding special laminates and pricing.

SPECIAL SERVICES

Special Carton Marking

With specially marked information N/C

Shipping

Ships **knocked down, FOB Bonduel, WI 54107, freight excluded.** Freight class 70.

Specifications and prices are subject to change without prior notice.

Ruckus® Activity Table (Freight Excluded Pricing)

1-1/4" Top - 74P Edge



Ruckus® Activity Table (Freight Excluded Pricing)

1-1/4" Top - 74P Edge

MODEL	A	MODEL NUMBER					Approx. Packaged Weight	Freight Excluded Pricing	Chrome Upcharge add to list price	Laminate Grade 2 add to list price
		Basic Model/Edge Style	Edge Color	Surface Finish	Base Finish	Base Option				
<p>Fixed Height Square Table, 29" H</p> <ul style="list-style-type: none"> • Casters and glides are interchangeable • Tables are designed for maximum leg spacing • All corners of surface are rounded • Specify casters/glides to wheelbarrow 	30"	RTEAC30	<input type="checkbox"/> <input type="checkbox"/> <input type="checkbox"/>	<input type="checkbox"/> <input type="checkbox"/> <input type="checkbox"/>	<input type="checkbox"/> <input type="checkbox"/>	<input type="checkbox"/> <input type="checkbox"/>	65.30#	\$ 516	\$ 70	\$ 27
	36"	RTEAC36	<input type="checkbox"/> <input type="checkbox"/> <input type="checkbox"/>	<input type="checkbox"/> <input type="checkbox"/> <input type="checkbox"/>	<input type="checkbox"/> <input type="checkbox"/>	<input type="checkbox"/> <input type="checkbox"/>	79.00#	590	70	37
	42"	RTEAC42	<input type="checkbox"/> <input type="checkbox"/> <input type="checkbox"/>	<input type="checkbox"/> <input type="checkbox"/> <input type="checkbox"/>	<input type="checkbox"/> <input type="checkbox"/>	<input type="checkbox"/> <input type="checkbox"/>	95.30#	664	70	37
	48"	RTEAC48	<input type="checkbox"/> <input type="checkbox"/> <input type="checkbox"/>	<input type="checkbox"/> <input type="checkbox"/> <input type="checkbox"/>	<input type="checkbox"/> <input type="checkbox"/>	<input type="checkbox"/> <input type="checkbox"/>	114.00#	713	70	37
RTEAC										
<p>Floor Height Adjustable Square Table, 12 to 19" H</p> <ul style="list-style-type: none"> • Tables are designed for maximum leg spacing • All corners of surface are rounded • Base only available in glides • Legs adjust with screws in 1" increments • Legs are factory pre-set at 19"H 	30"	RTEHC30	<input type="checkbox"/> <input type="checkbox"/> <input type="checkbox"/>	<input type="checkbox"/> <input type="checkbox"/> <input type="checkbox"/>	<input type="checkbox"/> <input type="checkbox"/>	<input type="checkbox"/> <input type="checkbox"/>	62.80#	\$ 551	\$ 75	\$ 27
	36"	RTEHC36	<input type="checkbox"/> <input type="checkbox"/> <input type="checkbox"/>	<input type="checkbox"/> <input type="checkbox"/> <input type="checkbox"/>	<input type="checkbox"/> <input type="checkbox"/>	<input type="checkbox"/> <input type="checkbox"/>	76.50#	619	75	37
	42"	RTEHC42	<input type="checkbox"/> <input type="checkbox"/> <input type="checkbox"/>	<input type="checkbox"/> <input type="checkbox"/> <input type="checkbox"/>	<input type="checkbox"/> <input type="checkbox"/>	<input type="checkbox"/> <input type="checkbox"/>	92.80#	689	75	37
	48"	RTEHC48	<input type="checkbox"/> <input type="checkbox"/> <input type="checkbox"/>	<input type="checkbox"/> <input type="checkbox"/> <input type="checkbox"/>	<input type="checkbox"/> <input type="checkbox"/>	<input type="checkbox"/> <input type="checkbox"/>	111.50#	737	75	37
RTEHC										
<p>Sit Height Adjustable Square Table, 20 to 33" H</p> <ul style="list-style-type: none"> • Casters and glides are interchangeable • Tables are designed for maximum leg spacing • All corners of surface are rounded • Specify casters/glides to wheelbarrow • Legs adjust with screws in 1" increments • Legs are factory pre-set at 29"H 	30"	RTEEC30	<input type="checkbox"/> <input type="checkbox"/> <input type="checkbox"/>	<input type="checkbox"/> <input type="checkbox"/> <input type="checkbox"/>	<input type="checkbox"/> <input type="checkbox"/>	<input type="checkbox"/> <input type="checkbox"/>	67.30#	\$ 586	\$ 77	\$ 27
	36"	RTEEC36	<input type="checkbox"/> <input type="checkbox"/> <input type="checkbox"/>	<input type="checkbox"/> <input type="checkbox"/> <input type="checkbox"/>	<input type="checkbox"/> <input type="checkbox"/>	<input type="checkbox"/> <input type="checkbox"/>	81.00#	658	77	37
	42"	RTEEC42	<input type="checkbox"/> <input type="checkbox"/> <input type="checkbox"/>	<input type="checkbox"/> <input type="checkbox"/> <input type="checkbox"/>	<input type="checkbox"/> <input type="checkbox"/>	<input type="checkbox"/> <input type="checkbox"/>	97.30#	732	77	37
	48"	RTEEC48	<input type="checkbox"/> <input type="checkbox"/> <input type="checkbox"/>	<input type="checkbox"/> <input type="checkbox"/> <input type="checkbox"/>	<input type="checkbox"/> <input type="checkbox"/>	<input type="checkbox"/> <input type="checkbox"/>	116.00#	783	77	37
RTEEC										
<p>Sit-Stand Height Adjustable Square Table, 29 to 42" H</p> <ul style="list-style-type: none"> • Casters and glides are interchangeable • Tables are designed for maximum leg spacing • All corners of surface are rounded • Specify casters/glides to wheelbarrow • Legs adjust with screws in 1" increments • Legs are factory pre-set at 29"H 	30"	RTEFC30	<input type="checkbox"/> <input type="checkbox"/> <input type="checkbox"/>	<input type="checkbox"/> <input type="checkbox"/> <input type="checkbox"/>	<input type="checkbox"/> <input type="checkbox"/>	<input type="checkbox"/> <input type="checkbox"/>	71.30#	\$ 602	\$ 88	\$ 27
	36"	RTEFC36	<input type="checkbox"/> <input type="checkbox"/> <input type="checkbox"/>	<input type="checkbox"/> <input type="checkbox"/> <input type="checkbox"/>	<input type="checkbox"/> <input type="checkbox"/>	<input type="checkbox"/> <input type="checkbox"/>	85.00#	675	88	37
	42"	RTEFC42	<input type="checkbox"/> <input type="checkbox"/> <input type="checkbox"/>	<input type="checkbox"/> <input type="checkbox"/> <input type="checkbox"/>	<input type="checkbox"/> <input type="checkbox"/>	<input type="checkbox"/> <input type="checkbox"/>	101.30#	750	88	37
	48"	RTEFC48	<input type="checkbox"/> <input type="checkbox"/> <input type="checkbox"/>	<input type="checkbox"/> <input type="checkbox"/> <input type="checkbox"/>	<input type="checkbox"/> <input type="checkbox"/>	<input type="checkbox"/> <input type="checkbox"/>	120.00#	798	88	37
RTEFC										

A **B** **C** **D** **E**

HOW TO ORDER

- Indicate the following information on order form:
- Quantity of each item.
 - Model number, including options. See "How To Build a Model Number".
 - Any special service required.

Note: • The indicates that a choice is required.
 • The absence of the indicates that no choice is required.
 • Alpha-numeric characters in place of indicate that no other alternatives are available.

HOW TO BUILD A MODEL NUMBER

Felt glides - GFT and Nylon glides - GNY

- A** Select basic model/edge style.
74P - 1-1/4" laminate top w/74P edge band
- B** Select edge color.
 Refer to the **Product Color Options** page in this price list.
- C** Select surface finish.
 Refer to the **Product Color Options** page in this price list.
- D** Select base finish.
 Refer to the **Product Color Options** page in this price list.
- E** Select base option.
CCC - Casters
BCF - Casters/felt glides
BCN - Casters/nylon glides
GFT - Felt glides
GNY - Nylon glides
 Base options for Floor Activity Height are ONLY

FINISH INFORMATION

Additional Laminate Offering
 KI offers laminates beyond those offered in the standard offering. Laminates that are currently available in the program can be viewed in KI product specification tools. Requests to add laminates to the program can be submitted via the product modification request process. Please note, requests to add laminates to the program must include the laminate manufacturer's name, color/pattern number, and finish code. Edge options are limited to standard edge colors. If a matching edge is required, this will need to be requested through the product modification request process and may be subject to additional costs. Due to varying manufacturing processes and quality issues with some laminates, some requests may be denied. Extended lead times and minimum order quantities may apply on orders containing special laminates. Contact the product modification team for questions or additional information regarding special laminates and pricing.

SPECIAL SERVICES

Special Carton Marking
 With specially marked information N/C

Shipping
 Ships **knocked down, FOB Bonduel, WI 54107, freight excluded.** Freight class 70.

Specifications and prices are subject to change without prior notice.

Ruckus® Activity Table (Freight Excluded Pricing)

1-1/4" Top - 74P Edge



Ruckus® Activity Table (Freight Excluded Pricing)

1-1/4" Top - 74P Edge

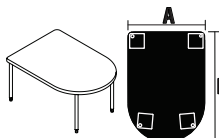
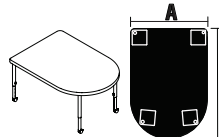
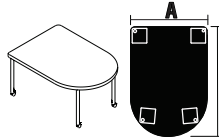
MODEL	A x B	MODEL NUMBER					Approx. Packaged Weight	Freight Excluded Pricing	Chrome Upcharge add to list price	Laminate Grade 2 add to list price
		Basic Model/Edge Style	Edge Color	Surface Finish	Base Finish	Base Option				
 <p>Fixed Height D-Shaped Table, 29" H</p> <ul style="list-style-type: none"> • Casters and glides are interchangeable • Tables are designed for maximum leg spacing • All corners of surface are rounded • Specify casters/glides to wheelbarrow 	42 x 60"	RTEAD4260	<input type="checkbox"/>	<input type="checkbox"/>	<input type="checkbox"/>	115.00#	\$ 742	\$ 70	\$ 53	
	48 x 60"	RTEAD4860	<input type="checkbox"/>	<input type="checkbox"/>	<input type="checkbox"/>	125.00#	750	70	53	
	48 x 72"	RTEAD4872	<input type="checkbox"/>	<input type="checkbox"/>	<input type="checkbox"/>	145.00#	835	70	53	
	60 x 72"	RTEAD6072	<input type="checkbox"/>	<input type="checkbox"/>	<input type="checkbox"/>	170.00#	846	70	105	
RTEAD										
 <p>Sit Height Adjustable D-Shaped Table, 20 to 33" H</p> <ul style="list-style-type: none"> • Casters and glides are interchangeable • Tables are designed for maximum leg spacing • All corners of surface are rounded • Specify casters/glides to wheelbarrow • Legs adjust with screws in 1" increments • Legs are factory pre-set at 29"H 	42 x 60"	RTEED4260	<input type="checkbox"/>	<input type="checkbox"/>	<input type="checkbox"/>	117.00#	\$ 809	\$ 77	\$ 53	
	48 x 60"	RTEED4860	<input type="checkbox"/>	<input type="checkbox"/>	<input type="checkbox"/>	127.00#	816	77	53	
	48 x 72"	RTEED4872	<input type="checkbox"/>	<input type="checkbox"/>	<input type="checkbox"/>	147.00#	902	77	53	
	60 x 72"	RTEED6072	<input type="checkbox"/>	<input type="checkbox"/>	<input type="checkbox"/>	172.00#	913	77	105	
RTEED										
 <p>Sit-Stand Height Adjustable D-Shaped Table, 29 to 42" H</p> <ul style="list-style-type: none"> • Casters and glides are interchangeable • Tables are designed for maximum leg spacing • All corners of surface are rounded • Specify casters/glides to wheelbarrow • Legs adjust with screws in 1" increments • Legs are factory pre-set at 29"H 	42 x 60"	RTEFD4260	<input type="checkbox"/>	<input type="checkbox"/>	<input type="checkbox"/>	121.00#	\$ 824	\$ 88	\$ 53	
	48 x 60"	RTEFD4860	<input type="checkbox"/>	<input type="checkbox"/>	<input type="checkbox"/>	131.00#	833	88	53	
	48 x 72"	RTEFD4872	<input type="checkbox"/>	<input type="checkbox"/>	<input type="checkbox"/>	151.00#	921	88	53	
	60 x 72"	RTEFD6072	<input type="checkbox"/>	<input type="checkbox"/>	<input type="checkbox"/>	176.00#	929	88	105	
RTEFD										

A **B** **C** **D** **E**

HOW TO ORDER

- Indicate the following information on order form:
1. Quantity of each item.
 2. Model number, including options. See "How To Build a Model Number".
 3. Any special service required.

Note: • The indicates that a choice is required.
 • The absence of the indicates that no choice is required.
 • Alpha-numeric characters in place of indicate that no other alternatives are available.

HOW TO BUILD A MODEL NUMBER

- A** Select basic model/edge style.
74P - 1-1/4" laminate top w/74P edge band
- B** Select edge color.
 Refer to the **Product Color Options** page in this price list.
- C** Select surface finish.
 Refer to the **Product Color Options** page in this price list.
- D** Select base finish.
 Refer to the **Product Color Options** page in this price list.
- E** Select base option.

CCC	- Casters
BCF	- Casters/felt glides
BCN	- Casters/nylon glides
GFT	- Felt glides
GNV	- Nylon glides

FINISH INFORMATION

Additional Laminate Offering
 KI offers laminates beyond those offered in the standard offering. Laminates that are currently available in the program can be viewed in KI product specification tools. Requests to add laminates to the program can be submitted via the product modification request process. Please note, requests to add laminates to the program must include the laminate manufacturer's name, color/pattern number, and finish code. Edge options are limited to standard edge colors. If a matching edge is required, this will need to be requested through the product modification request process and may be subject to additional costs. Due to varying manufacturing processes and quality issues with some laminates, some requests may be denied. Extended lead times and minimum order quantities may apply on orders containing special laminates. Contact the product modification team for questions or additional information regarding special laminates and pricing.

SPECIAL SERVICES

Special Carton Marking

With specially marked information N/C

Shipping
 Ships **knocked down, FOB Bonduel, WI 54107, freight excluded.** Freight class 70.

Specifications and prices are subject to change without prior notice.

Ruckus® Activity Table (Freight Excluded Pricing)

1-1/4" Top - 74P Edge



Ruckus® Activity Table (Freight Excluded Pricing)

1-1/4" Top - 74P Edge

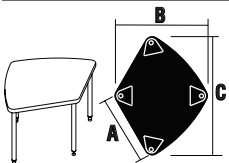
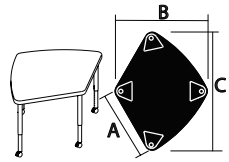
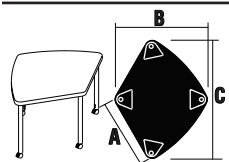
MODEL	A x B x C	MODEL NUMBER					Approx. Packaged Weight	Freight Excluded Pricing	Chrome Upcharge add to list price	Laminate Grade 2 add to list price
		Basic Model/Edge Style	Edge Color	Surface Finish	Base Finish	Base Option				
 <p>Fixed Height Diamond Table, 29" H</p> <ul style="list-style-type: none"> • Casters and glides are interchangeable • Tables are designed for maximum leg spacing • All corners of surface are rounded • Specify casters/glides to wheelbarrow • 3 tables combine to form a guitar pick 	30 x 39 x 50"	RTEAE30-74P	<input type="checkbox"/>	<input type="checkbox"/>	<input type="checkbox"/>	<input type="checkbox"/>	48.00#	\$ 697	\$ 70	\$ 53
	36 x 47 x 60"	RTEAE36-74P	<input type="checkbox"/>	<input type="checkbox"/>	<input type="checkbox"/>	<input type="checkbox"/>	59.00#	722	70	53
RTEAE										
 <p>Sit Height Adjustable Diamond Table, 20 to 33" H</p> <ul style="list-style-type: none"> • Casters and glides are interchangeable • Tables are designed for maximum leg spacing • All corners of surface are rounded • Specify casters/glides to wheelbarrow • Legs adjust with screws in 1" increments • Legs are factory pre-set at 29"H • 3 tables combine to form a guitar pick 	30 x 39 x 50"	RTEEE30-74P	<input type="checkbox"/>	<input type="checkbox"/>	<input type="checkbox"/>	<input type="checkbox"/>	50.00#	\$ 750	\$ 77	\$ 53
	36 x 47 x 60"	RTEEE36-74P	<input type="checkbox"/>	<input type="checkbox"/>	<input type="checkbox"/>	<input type="checkbox"/>	61.00#	777	77	53
RTEEE										
 <p>Sit-Stand Height Adjustable Diamond Table, 29 to 42" H</p> <ul style="list-style-type: none"> • Casters and glides are interchangeable • Tables are designed for maximum leg spacing • All corners of surface are rounded • Specify casters/glides to wheelbarrow • Legs adjust with screws in 1" increments • Legs are factory pre-set at 29"H • 3 tables combine to form a guitar pick 	30 x 39 x 50"	RTEFE30-74P	<input type="checkbox"/>	<input type="checkbox"/>	<input type="checkbox"/>	<input type="checkbox"/>	54.00#	\$ 789	\$ 88	\$ 53
	36 x 47 x 60"	RTEFE36-74P	<input type="checkbox"/>	<input type="checkbox"/>	<input type="checkbox"/>	<input type="checkbox"/>	65.00#	818	88	53
RTEFE										

A B C D E

HOW TO ORDER

- Indicate the following information on order form:
1. Quantity of each item.
 2. Model number, including options. See "How To Build a Model Number".
 3. Any special service required.

Note: • The indicates that a choice is required.

- The absence of the indicates that no choice is required.
- Alpha-numeric characters in place of indicate that no other alternatives are available.

HOW TO BUILD A MODEL NUMBER

- A** Select basic model/edge style.
74P - 1-1/4" laminate top w/74P edge band
- B** Select edge color.
Refer to the **Product Color Options** page in this price list.
- C** Select surface finish.
Refer to the **Product Color Options** page in this price list.
- D** Select base finish.
Refer to the **Product Color Options** page in this price list.
- E** Select base option.

CCC	- Casters
BCF	- Casters/felt glides
BCN	- Casters/nylon glides
GFT	- Felt glides
GNV	- Nylon glides

FINISH INFORMATION

Additional Laminate Offering

KI offers laminates beyond those offered in the standard offering. Laminates that are currently available in the program can be viewed in KI product specification tools. Requests to add laminates to the program can be submitted via the product modification request process. Please note, requests to add laminates to the program must include the laminate manufacturer's name, color/pattern number, and finish code. Edge options are limited to standard edge colors. If a matching edge is required, this will need to be requested through the product modification request process and may be subject to additional costs. Due to varying manufacturing processes and quality issues with some laminates, some requests may be denied. Extended lead times and minimum order quantities may apply on orders containing special laminates. Contact the product modification team for questions or additional information regarding special laminates and pricing.

SPECIAL SERVICES

Special Carton Marking

With specially marked information N/C

Shipping

Ships **knocked down, FOB Bonduel, WI 54107, freight excluded.** Freight class 70.

Specifications and prices are subject to change without prior notice.

Ruckus® Activity Table (Freight Excluded Pricing)

1-1/4" Top - 74P Edge



Ruckus® Activity Table (Freight Excluded Pricing)

1-1/4" Top - 74P Edge

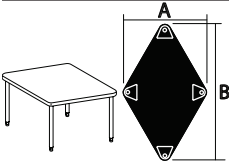
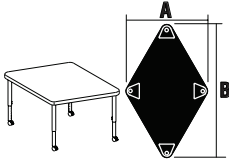
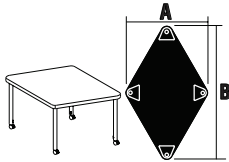
MODEL	Features	A x B	MODEL NUMBER					Approx. Packaged Weight	Freight Excluded Pricing	Chrome Upcharge add to list price	Laminate Grade 2 add to list price
			Basic Model/Edge Style	Edge Color	Surface Finish	Base Finish	Base Option				
 <p>Fixed Height Kite Table, 29" H</p> <ul style="list-style-type: none"> • Casters and glides are interchangeable • Tables are designed for maximum leg spacing • All corners of surface are rounded • Specify casters/glides to wheelbarrow • 3 Tables combine to form a hexagon 	Small	35 x 57"	RTEAJ34-74P	<input type="checkbox"/>	<input type="checkbox"/>	<input type="checkbox"/>	<input type="checkbox"/>	47.00#	\$ 668		
	Large	40 x 66"	RTEAJ39-74P	<input type="checkbox"/>	<input type="checkbox"/>	<input type="checkbox"/>	<input type="checkbox"/>	55.00#	762	\$ 70	\$ 53
 <p>Sit Height Adjustable Kite Table, 20 to 33" H</p> <ul style="list-style-type: none"> • Casters and glides are interchangeable • Tables are designed for maximum leg spacing • All corners of surface are rounded • Specify casters/glides to wheelbarrow • Legs adjust with screws in 1" increments • Legs are factory pre-set at 29"H • 3 Tables combine to form a hexagon 	Small	35 x 57"	RTEEJ34-74P	<input type="checkbox"/>	<input type="checkbox"/>	<input type="checkbox"/>	<input type="checkbox"/>	49.00#	\$ 710	\$ 77	
	Large	40 x 66"	RTEEJ39-74P	<input type="checkbox"/>	<input type="checkbox"/>	<input type="checkbox"/>	<input type="checkbox"/>	57.00#	800	77	53
 <p>Sit-Stand Height Adjustable Kite Table, 29 to 42" H</p> <ul style="list-style-type: none"> • Casters and glides are interchangeable • Tables are designed for maximum leg spacing • All corners of surface are rounded • Specify casters/glides to wheelbarrow • Legs adjust with screws in 1" increments • Legs are factory pre-set at 29"H • 3 Tables combine to form a hexagon 	Small	35 x 57"	RTEFJ34-74P	<input type="checkbox"/>	<input type="checkbox"/>	<input type="checkbox"/>	<input type="checkbox"/>	53.00#	\$ 759	\$ 88	
	Large	40 x 66"	RTEFJ39-74P	<input type="checkbox"/>	<input type="checkbox"/>	<input type="checkbox"/>	<input type="checkbox"/>	61.00#	853	88	53

A **B** **C** **D** **E**

HOW TO ORDER

- Indicate the following information on order form:
1. Quantity of each item.
 2. Model number, including options. See "How To Build a Model Number".
 3. Any special service required.

Note: • The indicates that a choice is required.
 • The absence of the indicates that no choice is required.
 • Alpha-numeric characters in place of indicate that no other alternatives are available.

HOW TO BUILD A MODEL NUMBER

- A** Select basic model/edge style.
74P - 1-1/4" laminate top w/74P edge band
- B** Select edge color.
 Refer to the **Product Color Options** page in this price list.
- C** Select surface finish.
 Refer to the **Product Color Options** page in this price list.
- D** Select base finish.
 Refer to the **Product Color Options** page in this price list.
- E** Select base option.

CCC	- Casters
BCF	- Casters/felt glides
BCN	- Casters/nylon glides
GFT	- Felt glides
GNV	- Nylon glides

FINISH INFORMATION

Additional Laminate Offering
 KI offers laminates beyond those offered in the standard offering. Laminates that are currently available in the program can be viewed in KI product specification tools. Requests to add laminates to the program can be submitted via the product modification request process. Please note, requests to add laminates to the program must include the laminate manufacturer's name, color/pattern number, and finish code. Edge options are limited to standard edge colors. If a matching edge is required, this will need to be requested through the product modification request process and may be subject to additional costs. Due to varying manufacturing processes and quality issues with some laminates, some requests may be denied. Extended lead times and minimum order quantities may apply on orders containing special laminates. Contact the product modification team for questions or additional information regarding special laminates and pricing.

SPECIAL SERVICES

Special Carton Marking
 With specially marked information N/C

Shipping
 Ships **knocked down, FOB Bonduel, WI 54107, freight excluded.** Freight class 70.

Specifications and prices are subject to change without prior notice.

Ruckus® Activity Table (Freight Excluded Pricing)

1-1/4" Top - 74P Edge



Ruckus® Activity Table (Freight Excluded Pricing)

1-1/4" Top - 74P Edge

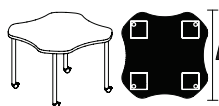
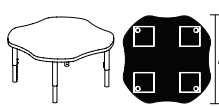
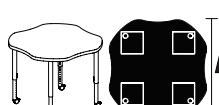
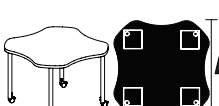
MODEL	A	MODEL NUMBER					Approx. Packaged Weight	Freight Excluded Pricing	Chrome Upcharge add to list price	Laminate Grade 2 add to list price
		Basic Model/Edge Style	Edge Color	Surface Finish	Base Finish	Base Option				
 <p>Fixed Height Clover Table, 29" H</p> <ul style="list-style-type: none"> • Casters and glides are interchangeable • Tables are designed for maximum leg spacing • All corners of surface are rounded • Specify casters/glides to wheelbarrow 	48"	RTEAY48	<input type="checkbox"/> <input type="checkbox"/>	<input type="checkbox"/> <input type="checkbox"/>	<input type="checkbox"/> <input type="checkbox"/>	<input type="checkbox"/> <input type="checkbox"/>	98.80#	\$ 631	\$ 70	\$ 37
	54"	RTEAY54	<input type="checkbox"/> <input type="checkbox"/>	<input type="checkbox"/> <input type="checkbox"/>	<input type="checkbox"/> <input type="checkbox"/>	<input type="checkbox"/> <input type="checkbox"/>	118.70#	652	70	53
RTEAY										
 <p>Floor Height Adjustable Clover Table, 12 to 19" H</p> <ul style="list-style-type: none"> • Tables are designed for maximum leg spacing • All corners of surface are rounded • Legs adjust with screws in 1" increments • Legs are factory pre-set at 19"H • Base only available in glides 	39"	RTEHY39	<input type="checkbox"/> <input type="checkbox"/>	<input type="checkbox"/> <input type="checkbox"/>	<input type="checkbox"/> <input type="checkbox"/>	<input type="checkbox"/> <input type="checkbox"/>	73.70#	\$ 638	\$ 75	\$ 37
	48"	RTEHY48	<input type="checkbox"/> <input type="checkbox"/>	<input type="checkbox"/> <input type="checkbox"/>	<input type="checkbox"/> <input type="checkbox"/>	<input type="checkbox"/> <input type="checkbox"/>	98.80#	690	75	37
RTEHY										
 <p>Sit Height Adjustable Clover Table, 20 to 33" H</p> <ul style="list-style-type: none"> • Casters and glides are interchangeable • Tables are designed for maximum leg spacing • All corners of surface are rounded • Specify casters/glides to wheelbarrow • Legs adjust with screws in 1" increments • Legs are factory pre-set at 29"H 	39"	RTEEY39	<input type="checkbox"/> <input type="checkbox"/>	<input type="checkbox"/> <input type="checkbox"/>	<input type="checkbox"/> <input type="checkbox"/>	<input type="checkbox"/> <input type="checkbox"/>	73.70#	\$ 641	\$ 77	\$ 37
	48"	RTEEY48	<input type="checkbox"/> <input type="checkbox"/>	<input type="checkbox"/> <input type="checkbox"/>	<input type="checkbox"/> <input type="checkbox"/>	<input type="checkbox"/> <input type="checkbox"/>	98.80#	693	77	37
	54"	RTEEY54	<input type="checkbox"/> <input type="checkbox"/>	<input type="checkbox"/> <input type="checkbox"/>	<input type="checkbox"/> <input type="checkbox"/>	<input type="checkbox"/> <input type="checkbox"/>	118.70#	716	77	53
RTEEY										
 <p>Sit-Stand Height Adjustable Clover Table, 29 to 42" H</p> <ul style="list-style-type: none"> • Casters and glides are interchangeable • Tables are designed for maximum leg spacing • All corners of surface are rounded • Specify casters/glides to wheelbarrow • Legs adjust with screws in 1" increments • Legs are factory pre-set at 29"H 	48"	RTEFY48	<input type="checkbox"/> <input type="checkbox"/>	<input type="checkbox"/> <input type="checkbox"/>	<input type="checkbox"/> <input type="checkbox"/>	<input type="checkbox"/> <input type="checkbox"/>	98.80#	\$ 719	\$ 88	\$ 37
	54"	RTEFY54	<input type="checkbox"/> <input type="checkbox"/>	<input type="checkbox"/> <input type="checkbox"/>	<input type="checkbox"/> <input type="checkbox"/>	<input type="checkbox"/> <input type="checkbox"/>	118.70#	739	88	53
RTEFY										

A **B** **C** **D** **E**

HOW TO ORDER

- Indicate the following information on order form:
1. Quantity of each item.
 2. Model number, including options. See "How To Build a Model Number".
 3. Any special service required.

Note: • The indicates that a choice is required.
 • The absence of the indicates that no choice is required.
 • Alpha-numeric characters in place of indicate that no other alternatives are available.

HOW TO BUILD A MODEL NUMBER

- A** Select basic model/edge style.
74P - 1-1/4" laminate top w/74P edge band
- B** Select edge color.
 Refer to the **Product Color Options** page in this price list.
- C** Select surface finish.
 Refer to the **Product Color Options** page in this price list.
- D** Select base finish.
 Refer to the **Product Color Options** page in this price list.
- E** Select base option.
CCC - Casters
BCF - Casters/felt glides
BCN - Casters/nylon glides
GFT - Felt glides
GNV - Nylon glides
 Base options for Floor Height Adjustable are

ONLY Felt glides - GFT and Nylon glides - GNV

FINISH INFORMATION

Additional Laminate Offering

KI offers laminates beyond those offered in the standard offering. Laminates that are currently available in the program can be viewed in KI product specification tools. Requests to add laminates to the program can be submitted via the product modification request process. Please note, requests to add laminates to the program must include the laminate manufacturer's name, color/pattern number, and finish code. Edge options are limited to standard edge colors. If a matching edge is required, this will need to be requested through the product modification request process and may be subject to additional costs. Due to varying manufacturing processes and quality issues with some laminates, some requests may be denied. Extended lead times and minimum order quantities may apply on orders containing special laminates. Contact the product modification team for questions or additional information regarding special laminates and pricing.

SPECIAL SERVICES

Special Carton Marking

With specially marked information N/C

Shipping

Ships **knocked down**, FOB Bonduel, WI 54107, **freight excluded**. Freight class 70.

Specifications and prices are subject to change without prior notice.

Ruckus® Activity Table (Freight Excluded Pricing)

1-1/4" Top - 74P Edge



Ruckus® Activity Table (Freight Excluded Pricing)

1-1/4" Top - 74P Edge

MODEL	A x B x C	MODEL NUMBER					Approx. Packaged Weight	Freight Excluded Pricing	Chrome Upcharge add to list price	Laminate Grade 2 add to list price
		Basic Model/Edge Style	Edge Color	Surface Finish	Base Finish	Base Option				
<p>Fixed Height 3-Leg Sprocket Table, 29" H</p> <ul style="list-style-type: none"> • Casters and glides are interchangeable • Tables are designed for maximum leg spacing • All corners of surface are rounded • Specify casters/glides to wheelbarrow • 3-Leg is primarily a 3-person table 	20 x 51 x 45"	RTEAG20	<input type="checkbox"/>	<input type="checkbox"/>	<input type="checkbox"/>	<input type="checkbox"/>	80.00#	\$ 692	\$ 52	\$ 53
	24 x 53 x 46"	RTEAG24	<input type="checkbox"/>	<input type="checkbox"/>	<input type="checkbox"/>	<input type="checkbox"/>	86.00#	700	52	53
RTEAG										
<p>Floor Height Adjustable 3-Leg Sprocket table, 12 to 19" H</p> <ul style="list-style-type: none"> • Tables are designed for maximum leg spacing • All corners of surface are rounded • Legs adjust with screws in 1" increments • Legs are factory pre-set at 19"H • 3-Leg is primarily a 3-person table • Base only available in glides 	20 x 51 x 45"	RTEHG20	<input type="checkbox"/>	<input type="checkbox"/>	<input type="checkbox"/>	<input type="checkbox"/>	78.20#	\$ 700	\$ 55	\$ 53
	24 x 53 x 46"	RTEHG24	<input type="checkbox"/>	<input type="checkbox"/>	<input type="checkbox"/>	<input type="checkbox"/>	84.20#	708	55	53
RTEHG										
<p>Sit Height Adjustable 3-Leg Sprocket Table, 20 to 33" H</p> <ul style="list-style-type: none"> • Casters and glides are interchangeable • Tables are designed for maximum leg spacing • All corners of surface are rounded • Specify casters/glides to wheelbarrow • Legs adjust with screws in 1" increments • Legs are factory pre-set at 29"H • 3-Leg is primarily a 3-person table 	20 x 51 x 45"	RTEEG20	<input type="checkbox"/>	<input type="checkbox"/>	<input type="checkbox"/>	<input type="checkbox"/>	81.50#	\$ 744	\$ 58	\$ 53
	24 x 53 x 46"	RTEEG24	<input type="checkbox"/>	<input type="checkbox"/>	<input type="checkbox"/>	<input type="checkbox"/>	87.50#	752	58	53
RTEEG										
<p>Sit-Stand Height Adjustable 3-Leg Sprocket Table, 29 to 42" H</p> <ul style="list-style-type: none"> • Casters and glides are interchangeable • Tables are designed for maximum leg spacing • All corners of surface are rounded • Specify casters/glides to wheelbarrow • Legs adjust with screws in 1" increments • Legs are factory pre-set at 29"H • 3-Leg is primarily a 3-person table 	20 x 51 x 45"	RTEFG20	<input type="checkbox"/>	<input type="checkbox"/>	<input type="checkbox"/>	<input type="checkbox"/>	84.50#	\$ 689	\$ 68	\$ 53
	24 x 53 x 46"	RTEFG24	<input type="checkbox"/>	<input type="checkbox"/>	<input type="checkbox"/>	<input type="checkbox"/>	90.50#	764	68	53
RTEFG										

A

B

C

D

E

HOW TO ORDER

- Indicate the following information on order form:
1. Quantity of each item.
 2. Model number, including options. See "How To Build a Model Number".
 3. Any special service required.

Note: • The indicates that a choice is required.

- The absence of the indicates that no choice is required.
- Alpha-numeric characters in place of indicate that no other alternatives are available.

HOW TO BUILD A MODEL NUMBER

A Select basic model/edge style.
74P - 1-1/4" laminate top w/74P edge band

B Select edge color.
 Refer to the **Product Color Options** page in this price list.

C Select surface finish.
 Refer to the **Product Color Options** page in this price list.

D Select base finish.
 Refer to the **Product Color Options** page in this price list.

E Select base option.
CCC - Casters
BCF - Casters/felt glides
BCN - Casters/nylon glides
GFT - Felt glides
GNV - Nylon glides
 Base options for Floor Height Adjustable are

ONLY Felt glides - GFT and Nylon glides - GNV

FINISH INFORMATION

Additional Laminate Offering

KI offers laminates beyond those offered in the standard offering. Laminates that are currently available in the program can be viewed in KI product specification tools. Requests to add laminates to the program can be submitted via the product modification request process. Please note, requests to add laminates to the program must include the laminate manufacturer's name, color/pattern number, and finish code. Edge options are limited to standard edge colors. If a matching edge is required, this will need to be requested through the product modification request process and may be subject to additional costs. Due to varying manufacturing processes and quality issues with some laminates, some requests may be denied. Extended lead times and minimum order quantities may apply on orders containing special laminates. Contact the product modification team for questions or additional information regarding special laminates and pricing.

SPECIAL SERVICES

Special Carton Marking

With specially marked information N/C

Shipping
 Ships **knocked down, FOB Bonduel, WI 54107, freight excluded.** Freight class 70.

Specifications and prices are subject to change without prior notice.

Ruckus® Activity Table (Freight Excluded Pricing)

1-1/4" Top - 74P Edge



Ruckus® Activity Table (Freight Excluded Pricing)

1-1/4" Top - 74P Edge

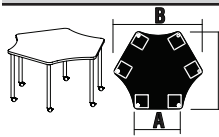
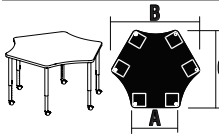
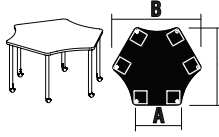
MODEL	A x B x C	MODEL NUMBER					Approx. Packaged Weight	Freight Excluded Pricing	Chrome Upcharge add to list price	Laminate Grade 2 add to list price
		Basic Model/Edge Style	Edge Color	Surface Finish	Base Finish	Base Option				
 <p>Fixed Height 6-Leg Sprocket Table, 29" H</p> <ul style="list-style-type: none"> • Casters and glides are interchangeable • Tables are designed for maximum leg spacing • All corners of surface are rounded • Specify casters/glides to wheelbarrow • 6-Leg can accommodate up to 6 people 	30 x 55 x 48"	RTEAG30	<input type="checkbox"/> <input type="checkbox"/>	<input type="checkbox"/> <input type="checkbox"/>	<input type="checkbox"/>	<input type="checkbox"/> <input type="checkbox"/>	118.00#	\$ 921	\$ 106	\$ 53
 <p>Sit Height Adjustable 6-Leg Sprocket Table, 20 to 33" H</p> <ul style="list-style-type: none"> • Casters and glides are interchangeable • Tables are designed for maximum leg spacing • All corners of surface are rounded • Specify casters/glides to wheelbarrow • Legs adjust with screws in 1" increments • Legs are factory pre-set at 29"H • 6-Leg can accommodate up to 6 people 	30 x 55 x 48"	RTEEG30	<input type="checkbox"/> <input type="checkbox"/>	<input type="checkbox"/> <input type="checkbox"/>	<input type="checkbox"/>	<input type="checkbox"/> <input type="checkbox"/>	121.00#	\$ 1021	\$ 116	\$ 53
 <p>Sit-Stand Height Adjustable 6-Leg Sprocket Table, 29 to 42" H</p> <ul style="list-style-type: none"> • Casters and glides are interchangeable • Tables are designed for maximum leg spacing • All corners of surface are rounded • Specify casters/glides to wheelbarrow • Legs adjust with screws in 1" increments • Legs are factory pre-set at 29"H • 6-Leg can accommodate up to 6 people 	30 x 55 x 48"	RTEFG30	<input type="checkbox"/> <input type="checkbox"/>	<input type="checkbox"/> <input type="checkbox"/>	<input type="checkbox"/>	<input type="checkbox"/> <input type="checkbox"/>	127.00#	\$ 1048	\$ 134	\$ 53

A **B** **C** **D** **E**

HOW TO ORDER

- Indicate the following information on order form:
1. Quantity of each item.
 2. Model number, including options. See "How To Build a Model Number".
 3. Any special service required.

Note: • The indicates that a choice is required.

- The absence of the indicates that no choice is required.
- Alpha-numeric characters in place of indicate that no other alternatives are available.

HOW TO BUILD A MODEL NUMBER

- A** Select basic model/edge style.
74P - 1-1/4" laminate top w/74P edge band
- B** Select edge color.
Refer to the **Product Color Options** page in this price list.
- C** Select surface finish.
Refer to the **Product Color Options** page in this price list.
- D** Select base finish.
Refer to the **Product Color Options** page in this price list.
- E** Select base option.

CCC	- Casters
BCF	- Casters/felt glides
BCN	- Casters/nylon glides
GFT	- Felt glides
GNY	- Nylon glides

FINISH INFORMATION

Additional Laminate Offering

KI offers laminates beyond those offered in the standard offering. Laminates that are currently available in the program can be viewed in KI product specification tools. Requests to add laminates to the program can be submitted via the product modification request process. Please note, requests to add laminates to the program must include the laminate manufacturer's name, color/pattern number, and finish code. Edge options are limited to standard edge colors. If a matching edge is required, this will need to be requested through the product modification request process and may be subject to additional costs. Due to varying manufacturing processes and quality issues with some laminates, some requests may be denied. Extended lead times and minimum order quantities may apply on orders containing special laminates. Contact the product modification team for questions or additional information regarding special laminates and pricing.

SPECIAL SERVICES

Special Carton Marking

With specially marked information N/C

Shipping

Ships **knocked down**, **FOB Bonduel, WI 54107**, **freight excluded**. Freight class 70.

Specifications and prices are subject to change without prior notice.

Ruckus® Activity Table (Freight Excluded Pricing)

1-1/4" Top - 74P Edge



Ruckus® Activity Table (Freight Excluded Pricing)

1-1/4" Top - 74P Edge

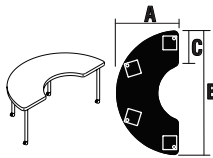
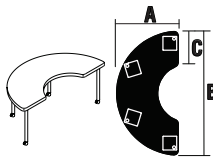
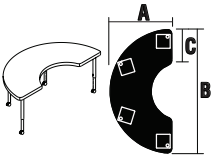
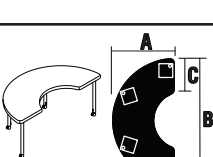
MODEL	A x B x C	MODEL NUMBER					Approx. Packaged Weight	Freight Excluded Pricing	Chrome Upcharge add to list price	Laminate Grade 2 add to list price
		Basic Model/Edge Style	Edge Color	Surface Finish	Base Finish	Base Option				
 <p>Fixed Height Kidney Table, 29" H</p> <ul style="list-style-type: none"> • Casters and glides are interchangeable • Tables are designed for maximum leg spacing • All corners of surface are rounded • Specify casters/glides to wheelbarrow 	36 x 72 x 20"	RTEAF367220	<input type="checkbox"/>	<input type="checkbox"/>	<input type="checkbox"/>	<input type="checkbox"/>	93.00#	\$ 834	\$ 70	\$ 53
	36 x 72 x 24"	RTEAF367224	<input type="checkbox"/>	<input type="checkbox"/>	<input type="checkbox"/>	<input type="checkbox"/>	97.00#	841	70	53
	36 x 83 x 30"	RTEAF368430	<input type="checkbox"/>	<input type="checkbox"/>	<input type="checkbox"/>	<input type="checkbox"/>	105.00#	1019	70	74
	48 x 72 x 20"	RTEAF487220	<input type="checkbox"/>	<input type="checkbox"/>	<input type="checkbox"/>	<input type="checkbox"/>	125.00#	901	70	53
	48 x 72 x 24"	RTEAF487224	<input type="checkbox"/>	<input type="checkbox"/>	<input type="checkbox"/>	<input type="checkbox"/>	127.00#	908	70	53
	48 x 84 x 30"	RTEAF488430	<input type="checkbox"/>	<input type="checkbox"/>	<input type="checkbox"/>	<input type="checkbox"/>	140.00#	1069	70	74
RTEAF										
 <p>Floor Height Adjustable Kidney Table, 12 to 19" H</p> <ul style="list-style-type: none"> • Tables are designed for maximum leg spacing • All corners of surface are rounded • Legs adjust with screws in 1" increments • Legs are factory pre-set at 19"H • Base only available in glides 	36 x 72 x 20"	RTEHF367220	<input type="checkbox"/>	<input type="checkbox"/>	<input type="checkbox"/>	<input type="checkbox"/>	89.50#	\$ 849	\$ 75	\$ 53
	36 x 72 x 24"	RTEHF367224	<input type="checkbox"/>	<input type="checkbox"/>	<input type="checkbox"/>	<input type="checkbox"/>	94.50#	856	75	53
	36 x 84 x 30"	RTEHF368430	<input type="checkbox"/>	<input type="checkbox"/>	<input type="checkbox"/>	<input type="checkbox"/>	102.50#	1026	75	74
	48 x 72 x 20"	RTEHF487220	<input type="checkbox"/>	<input type="checkbox"/>	<input type="checkbox"/>	<input type="checkbox"/>	122.50#	914	75	53
	48 x 72 x 24"	RTEHF487224	<input type="checkbox"/>	<input type="checkbox"/>	<input type="checkbox"/>	<input type="checkbox"/>	124.50#	922	75	53
	48 x 84 x 30"	RTEHF488430	<input type="checkbox"/>	<input type="checkbox"/>	<input type="checkbox"/>	<input type="checkbox"/>	137.50#	1071	75	74
RTEHF										
 <p>Sit Height Adjustable Kidney Table, 20 to 33" H</p> <ul style="list-style-type: none"> • Casters and glides are interchangeable • Tables are designed for maximum leg spacing • All corners of surface are rounded • Specify casters/glides to wheelbarrow • Legs adjust with screws in 1" increments • Legs are factory pre-set at 29"H 	36 x 72 x 20"	RTEEF367220	<input type="checkbox"/>	<input type="checkbox"/>	<input type="checkbox"/>	<input type="checkbox"/>	95.00#	\$ 902	\$ 77	\$ 53
	36 x 72 x 24"	RTEEF367224	<input type="checkbox"/>	<input type="checkbox"/>	<input type="checkbox"/>	<input type="checkbox"/>	99.00#	910	77	53
	36 x 83 x 30"	RTEEF368430	<input type="checkbox"/>	<input type="checkbox"/>	<input type="checkbox"/>	<input type="checkbox"/>	107.00#	1088	77	74
	48 x 72 x 20"	RTEEF487220	<input type="checkbox"/>	<input type="checkbox"/>	<input type="checkbox"/>	<input type="checkbox"/>	127.00#	970	77	53
	48 x 72 x 24"	RTEEF487224	<input type="checkbox"/>	<input type="checkbox"/>	<input type="checkbox"/>	<input type="checkbox"/>	129.00#	978	77	53
	48 x 84 x 30"	RTEEF488430	<input type="checkbox"/>	<input type="checkbox"/>	<input type="checkbox"/>	<input type="checkbox"/>	142.00#	1137	77	74
RTEEF										
 <p>Sit-Stand Height Adjustable Kidney Table, 29 to 42" H</p> <ul style="list-style-type: none"> • Casters and glides are interchangeable • Tables are designed for maximum leg spacing • All corners of surface are rounded • Specify casters/glides to wheelbarrow • Legs adjust with screws in 1" increments • Legs are factory pre-set at 29"H 	36 x 72 x 20"	RTEFF367220	<input type="checkbox"/>	<input type="checkbox"/>	<input type="checkbox"/>	<input type="checkbox"/>	99.00#	\$ 927	\$ 88	\$ 53
	36 x 72 x 24"	RTEFF367224	<input type="checkbox"/>	<input type="checkbox"/>	<input type="checkbox"/>	<input type="checkbox"/>	103.00#	921	88	53
	36 x 83 x 30"	RTEFF368430	<input type="checkbox"/>	<input type="checkbox"/>	<input type="checkbox"/>	<input type="checkbox"/>	111.00#	1105	88	74
	48 x 72 x 20"	RTEFF487220	<input type="checkbox"/>	<input type="checkbox"/>	<input type="checkbox"/>	<input type="checkbox"/>	131.00#	987	88	53
	48 x 72 x 24"	RTEFF487224	<input type="checkbox"/>	<input type="checkbox"/>	<input type="checkbox"/>	<input type="checkbox"/>	133.00#	995	88	53
	48 x 84 x 30"	RTEFF488430	<input type="checkbox"/>	<input type="checkbox"/>	<input type="checkbox"/>	<input type="checkbox"/>	146.00#	1153	88	74
RTEFF										

A **B** **C** **D** **E**

HOW TO ORDER

- Indicate the following information on order form:
- Quantity of each item.
 - Model number, including options. See "How To Build a Model Number".
 - Any special service required.

Note: • The indicates that a choice is required.

- The absence of the indicates that no choice is required.
- Alpha-numeric characters in place of indicate that no other alternatives are available.

HOW TO BUILD A MODEL NUMBER

ONLY Felt glides - GFT and Nylon glides - GNY

- A** Select basic model/edge style.
74P - 1-1/4" laminate top w/74P edge band
- B** Select edge color.
Refer to the **Product Color Options** page in this price list.
- C** Select surface finish.
Refer to the **Product Color Options** page in this price list.
- D** Select base finish.
Refer to the **Product Color Options** page in this price list.
- E** Select base option.
- CCC** - Casters
 - BCF** - Casters/felt glides
 - BCN** - Casters/nylon glides
 - GFT** - Felt glides
 - GNY** - Nylon glides
- Base options for Floor Height Adjustable are

FINISH INFORMATION

Additional Laminate Offering

KI offers laminates beyond those offered in the standard offering. Laminates that are currently available in the program can be viewed in KI product specification tools. Requests to add laminates to the program can be submitted via the product modification request process. Please note, requests to add laminates to the program must include the laminate manufacturer's name, color/pattern number, and finish code. Edge options are limited to standard edge colors. If a matching edge is required, this will need to be requested through the product modification request process and may be subject to additional costs. Due to varying manufacturing processes and quality issues with some laminates, some requests may be denied. Extended lead times and minimum order quantities may apply on orders containing special laminates. Contact the product modification team for questions or additional information regarding special laminates and pricing.

SPECIAL SERVICES

Special Carton Marking

With specially marked information N/C

Shipping

Ships **knocked down**, **FOB Bonduel, WI 54107**, **freight excluded**. Freight class 70.

Specifications and prices are subject to change without prior notice.

Ruckus® Activity Table (Freight Excluded Pricing)

1-1/4" Top - 74P Edge



Ruckus® Activity Table (Freight Excluded Pricing)

1-1/4" Top - 74P Edge

MODEL	A x B x C	MODEL NUMBER					Approx. Packaged Weight	Freight Excluded Pricing	Chrome Upcharge add to list price	Laminate Grade 2 add to list price
		Basic Model/Edge Style	Edge Color	Surface Finish	Base Finish	Base Option				
<p>Fixed Height Horseshoe Table, 29" H</p> <ul style="list-style-type: none"> • Casters and glides are interchangeable • Tables are designed for maximum leg spacing • All corners of surface are rounded • Specify casters/glides to wheelbarrow 	48 x 72 x 20"	RTEAH487220	<input type="checkbox"/>	<input type="checkbox"/>	<input type="checkbox"/>	107.00#	\$ 996	\$ 70	\$ 53	
	48 x 80 x 24"	RTEAH488024	<input type="checkbox"/>	<input type="checkbox"/>	<input type="checkbox"/>	120.00#	1168	70	74	
	48 x 92 x 30"	RTEAH489230	<input type="checkbox"/>	<input type="checkbox"/>	<input type="checkbox"/>	139.00#	1175	70	74	
	60 x 66 x 20"	RTEAH606620	<input type="checkbox"/>	<input type="checkbox"/>	<input type="checkbox"/>	121.00#	1008	70	105	
	60 x 72 x 24"	RTEAH607224	<input type="checkbox"/>	<input type="checkbox"/>	<input type="checkbox"/>	138.00#	1025	70	105	
	60 x 86 x 30"	RTEAH608630	<input type="checkbox"/>	<input type="checkbox"/>	<input type="checkbox"/>	161.00#	1174	70	105	
<p>Floor Height Adjustable Horseshoe Table, 12 to 19" H</p> <ul style="list-style-type: none"> • Tables are designed for maximum leg spacing • All corners of surface are rounded • Legs adjust with screws in 1" increments • Legs are factory pre-set at 19"H • Base only available in glides 	48 x 72 x 20"	RTEHH487220	<input type="checkbox"/>	<input type="checkbox"/>	<input type="checkbox"/>	104.50#	\$ 1004	\$ 75	\$ 53	
	48 x 80 x 24"	RTEHH488024	<input type="checkbox"/>	<input type="checkbox"/>	<input type="checkbox"/>	117.50#	1167	75	74	
	48 x 92 x 30"	RTEHH489230	<input type="checkbox"/>	<input type="checkbox"/>	<input type="checkbox"/>	136.50#	1168	75	74	
	60 x 66 x 20"	RTEHH606620	<input type="checkbox"/>	<input type="checkbox"/>	<input type="checkbox"/>	118.50#	1017	75	105	
	60 x 72 x 24"	RTEHH607224	<input type="checkbox"/>	<input type="checkbox"/>	<input type="checkbox"/>	135.50#	1032	75	105	
	60 x 86 x 30"	RTEHH608630	<input type="checkbox"/>	<input type="checkbox"/>	<input type="checkbox"/>	158.50#	1174	75	105	
<p>Sit Height Adjustable Horseshoe Table, 20 to 33" H</p> <ul style="list-style-type: none"> • Casters and glides are interchangeable • Tables are designed for maximum leg spacing • All corners of surface are rounded • Specify casters/glides to wheelbarrow • Legs adjust with screws in 1" increments • Legs are factory pre-set at 29"H 	48 x 72 x 20"	RTEEH487220	<input type="checkbox"/>	<input type="checkbox"/>	<input type="checkbox"/>	109.00#	\$ 1066	\$ 77	\$ 53	
	48 x 80 x 24"	RTEEH488024	<input type="checkbox"/>	<input type="checkbox"/>	<input type="checkbox"/>	122.00#	1240	77	74	
	48 x 92 x 30"	RTEEH489230	<input type="checkbox"/>	<input type="checkbox"/>	<input type="checkbox"/>	141.00#	1240	77	74	
	60 x 66 x 20"	RTEEH606620	<input type="checkbox"/>	<input type="checkbox"/>	<input type="checkbox"/>	123.00#	1078	77	105	
	60 x 72 x 24"	RTEEH607224	<input type="checkbox"/>	<input type="checkbox"/>	<input type="checkbox"/>	140.00#	1096	77	105	
	60 x 86 x 30"	RTEEH608630	<input type="checkbox"/>	<input type="checkbox"/>	<input type="checkbox"/>	163.00#	1245	77	105	
<p>Sit-Stand Height Adjustable Horseshoe Table, 29 to 42" H</p> <ul style="list-style-type: none"> • Casters and glides are interchangeable • Tables are designed for maximum leg spacing • All corners of surface are rounded • Specify casters/glides to wheelbarrow • Legs adjust with screws in 1" increments • Legs are factory pre-set at 29"H 	48 x 72 x 20"	RTEFH487220	<input type="checkbox"/>	<input type="checkbox"/>	<input type="checkbox"/>	113.00#	\$ 1085	\$ 88	\$ 53	
	48 x 80 x 24"	RTEFH488024	<input type="checkbox"/>	<input type="checkbox"/>	<input type="checkbox"/>	126.00#	1257	88	74	
	48 x 92 x 30"	RTEFH489230	<input type="checkbox"/>	<input type="checkbox"/>	<input type="checkbox"/>	145.00#	1257	88	74	
	60 x 66 x 20"	RTEFH606620	<input type="checkbox"/>	<input type="checkbox"/>	<input type="checkbox"/>	127.00#	1096	88	105	
	60 x 72 x 24"	RTEFH607224	<input type="checkbox"/>	<input type="checkbox"/>	<input type="checkbox"/>	144.00#	1113	88	105	
	60 x 86 x 30"	RTEFH608630	<input type="checkbox"/>	<input type="checkbox"/>	<input type="checkbox"/>	167.00#	1263	88	105	

A **B** **C** **D** **E**

HOW TO ORDER

- Indicate the following information on order form:
- Quantity of each item.
 - Model number, including options. See "How To Build a Model Number".
 - Any special service required.

Note: • The indicates that a choice is required.
 • The absence of the indicates that no choice is required.
 • Alpha-numeric characters in place of indicate that no other alternatives are available.

HOW TO BUILD A MODEL NUMBER

- A** Select basic model/edge style.
74P - 1-1/4" laminate top w/74P edge band
- B** Select edge color.
 Refer to the **Product Color Options** page in this price list.
- C** Select surface finish.
 Refer to the **Product Color Options** page in this price list.
- D** Select base finish.
 Refer to the **Product Color Options** page in this price list.
- E** Select base option.
CCC - Casters
BCF - Casters/felt glides
BCN - Casters/nylon glides
GFT - Felt glides
GNV - Nylon glides
 Base options for Floor Height Adjustable are

ONLY Felt glides - GFT and Nylon glides - GNV

FINISH INFORMATION

Additional Laminate Offering
 KI offers laminates beyond those offered in the standard offering. Laminates that are currently available in the program can be viewed in KI product specification tools. Requests to add laminates to the program can be submitted via the product modification request process. Please note, requests to add laminates to the program must include the laminate manufacturer's name, color/pattern number, and finish code. Edge options are limited to standard edge colors. If a matching edge is required, this will need to be requested through the product modification request process and may be subject to additional costs. Due to varying manufacturing processes and quality issues with some laminates, some requests may be denied. Extended lead times and minimum order quantities may apply on orders containing special laminates. Contact the product modification team for questions or additional information regarding special laminates and pricing.

SPECIAL SERVICES

Special Carton Marking
 With specially marked information N/C

Shipping
 Ships **knocked down, FOB Bonduel, WI 54107, freight excluded.** Freight class 70.

Specifications and prices are subject to change without prior notice.

Ruckus® Activity Table (Freight Excluded Pricing)

1-1/4" Top - 74P Edge



Ruckus® Activity Table (Freight Excluded Pricing)

1-1/4" Top - 74P Edge

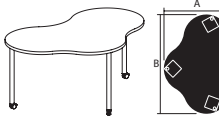
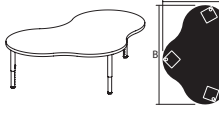
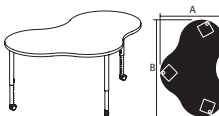
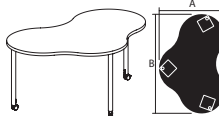
MODEL	A x B	MODEL NUMBER					Approx. Packaged Weight	Freight Excluded Pricing	Chrome Upcharge add to list price	Laminate Grade 2 add to list price
		Basic Model/Edge Style	Edge Color	Surface Finish	Base Finish	Base Option				
 <p>Fixed Height Amoeba Table, 29" H</p> <ul style="list-style-type: none"> • Casters and glides are interchangeable • Tables are designed for maximum leg spacing • All corners of surface are rounded • Specify casters/glides to wheelbarrow 	36 x 48"	RTEAU3648-74P	<input type="checkbox"/>	<input type="checkbox"/>	<input type="checkbox"/>	<input type="checkbox"/>	65.00#	\$ 544	\$ 51	\$ 53
	43 x 65"	RTEAU4365-74P	<input type="checkbox"/>	<input type="checkbox"/>	<input type="checkbox"/>	<input type="checkbox"/>	82.00#	764	51	53
RTEAU										
 <p>Floor Height Adjustable Amoeba Table, 12 to 19" H</p> <ul style="list-style-type: none"> • Tables are designed for maximum leg spacing • All corners of surface are rounded • Legs adjust with screws in 1" increments • Legs are factory pre-set at 19"H • Base only available in glides 	36 x 48"	RTEHU3648-74P	<input type="checkbox"/>	<input type="checkbox"/>	<input type="checkbox"/>	<input type="checkbox"/>	62.00#	\$ 591	\$ 54	\$ 53
	43 x 65"	RTEHU4365-74P	<input type="checkbox"/>	<input type="checkbox"/>	<input type="checkbox"/>	<input type="checkbox"/>	80.00#	811	54	53
RTEHU										
 <p>Sit Height Adjustable Amoeba Table, 20 to 33" H</p> <ul style="list-style-type: none"> • Casters and glides are interchangeable • Tables are designed for maximum leg spacing • All corners of surface are rounded • Specify casters/glides to wheelbarrow • Legs adjust with screws in 1" increments • Legs are factory pre-set at 29"H 	36 x 48"	RTEEU3648-74P	<input type="checkbox"/>	<input type="checkbox"/>	<input type="checkbox"/>	<input type="checkbox"/>	65.00#	\$ 593	\$ 56	\$ 53
	43 x 65"	RTEEU4365-74P	<input type="checkbox"/>	<input type="checkbox"/>	<input type="checkbox"/>	<input type="checkbox"/>	65.00#	813	56	53
RTEEU										
 <p>Sit-Stand Height Adjustable Amoeba Table, 29 to 42" H</p> <ul style="list-style-type: none"> • Casters and glides are interchangeable • Tables are designed for maximum leg spacing • All corners of surface are rounded • Specify casters/glides to wheelbarrow • Legs adjust with screws in 1" increments • Legs are factory pre-set at 29"H 	36 x 48"	RTEFU3648-74P	<input type="checkbox"/>	<input type="checkbox"/>	<input type="checkbox"/>	<input type="checkbox"/>	69.00#	\$ 608	\$ 65	\$ 53
	43 x 65"	RTEFU4365-74P	<input type="checkbox"/>	<input type="checkbox"/>	<input type="checkbox"/>	<input type="checkbox"/>	87.00#	828	65	53
RTEFU										

A **B** **C** **D** **E**

HOW TO ORDER

- Indicate the following information on order form:
1. Quantity of each item.
 2. Model number, including options. See "How To Build a Model Number".
 3. Any special service required.

Note: • The indicates that a choice is required.

- The absence of the indicates that no choice is required.
- Alpha-numeric characters in place of indicate that no other alternatives are available.

HOW TO BUILD A MODEL NUMBER

- A** Select basic model/edge style.
74P - 1-1/4" laminate top w/74P edge band
- B** Select edge color.
Refer to the **Product Color Options** page in this price list.
- C** Select surface finish.
Refer to the **Product Color Options** page in this price list.
- D** Select base finish.
Refer to the **Product Color Options** page in this price list.
- E** Select base option.
- CCC** - Casters
 - BCF** - Casters/felt glides
 - BCN** - Casters/nylon glides
 - GFT** - Felt glides
 - GNY** - Nylon glides
- Base options for Floor Height Adjustable are

ONLY Felt glides - GFT and Nylon glides - GNY

FINISH INFORMATION

Additional Laminate Offering

KI offers laminates beyond those offered in the standard offering. Laminates that are currently available in the program can be viewed in KI product specification tools. Requests to add laminates to the program can be submitted via the product modification request process. Please note, requests to add laminates to the program must include the laminate manufacturer's name, color/pattern number, and finish code. Edge options are limited to standard edge colors. If a matching edge is required, this will need to be requested through the product modification request process and may be subject to additional costs. Due to varying manufacturing processes and quality issues with some laminates, some requests may be denied. Extended lead times and minimum order quantities may apply on orders containing special laminates. Contact the product modification team for questions or additional information regarding special laminates and pricing.

SPECIAL SERVICES

Special Carton Marking

With specially marked information N/C

Shipping

Ships **knocked down**, FOB Bonduel, WI 54107, **freight excluded**. Freight class 70.

Specifications and prices are subject to change without prior notice.

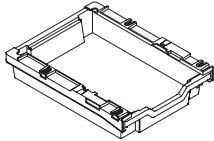
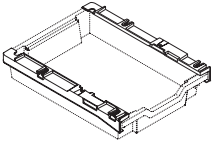

MODEL	MODEL NUMBER	Approx. Packaged Weight	Freight Excluded Pricing
	Basic Model		
 <p>Removable Tote Storage Kit, with 3" Tote (for Ruckus desk & tables only)</p> <ul style="list-style-type: none"> Undersurface rails are transparent For Ruckus desk and tables with pre-drilled holes 	RKUSRT1	3.00#	\$ 47
	RKAU		
 <p>Removable Tote Storage Rail Only Kit (for Ruckus desk & tables only)</p> <ul style="list-style-type: none"> Undersurface rails are transparent For Ruckus desk and tables with pre-drilled holes 	RKUSRTR01	0.80#	\$ 31
	RKAU		

A

HOW TO ORDER

- Indicate the following information on order form:
- Quantity of each item.
 - Model number, including options. See "How To Build a Model Number".
 - Any special service required.

Note:

- The indicates that a choice is required.
- The absence of the indicates that no choice is required.
- Alpha-numeric characters in place of indicate that no other alternatives are available.

HOW TO BUILD A MODEL NUMBER

A Select basic model.

SPECIAL SERVICES

Special Carton Marking

With specially marked information N/C

Shipping



Ships **assembled, FOB Bonduel, WI 54107, freight excluded.** Freight class 70.

Specifications and prices are subject to change without prior notice.

Ruckus® Worktable (Freight Excluded Pricing)



Ruckus® Worktable (Freight Excluded Pricing)

D x W x H	MODEL NUMBER											Approx. Packaged Weight	1-1/4" Laminate Top with 74P Edge (74P)	1" Phenolic Resin Top (RNT)	1-3/4" Butcher Block Wood Top (WBB)	Laminate Grade 2 add to list price	WPA1 Power Option	WPB1 Power Option
	Basic Model	Power Option	Power Module Color	Book Bag Hook	Base Color	Top Color	Edge Color	Door Color	Pull Option	Lock Option	Lock Color							
 RCWT Single-Faced 2x2 Cubby Storage, Open • Toolless removable worksurface • Worksurface dimensions: 30x54 • Storage base dimensions: 18x30 • Unit ships partially assembled, casters and worksurface are field installed • Shown with optional power module WPA1 • Cubby spaces 14"Hx13.5"Wx17"D	30 x 54 x 36	RCWT305436COP-74P	<input type="checkbox"/>	<input type="checkbox"/>	<input type="checkbox"/>	<input type="checkbox"/>	<input type="checkbox"/>	<input type="checkbox"/>	<input type="checkbox"/>	<input type="checkbox"/>	<input type="checkbox"/>							
	30 x 54 x 35-3/4	RCWT305436COP-RNT	<input type="checkbox"/>	<input type="checkbox"/>	<input type="checkbox"/>	<input type="checkbox"/>	<input type="checkbox"/>	<input type="checkbox"/>	<input type="checkbox"/>	<input type="checkbox"/>	<input type="checkbox"/>	<input type="checkbox"/>						
	30 x 54 x 36-1/2	RCWT305436COP-WBB	<input type="checkbox"/>	<input type="checkbox"/>	<input type="checkbox"/>	<input type="checkbox"/>	<input type="checkbox"/>	<input type="checkbox"/>	<input type="checkbox"/>	<input type="checkbox"/>	<input type="checkbox"/>	<input type="checkbox"/>						
 RCWT Single-Faced 2x2 Cubby Storage, With Doors • Toolless removable worksurface • Worksurface dimensions: 30x54 • Storage base dimensions: 18x30 • Unit ships partially assembled, casters and worksurface are field installed • Shown with optional power module WPA1 • Cubby spaces 14"Hx13.5"Wx17"D • Secure locking doors	30 x 54 x 36	RCWT305436CDR-74P	<input type="checkbox"/>	<input type="checkbox"/>	<input type="checkbox"/>	<input type="checkbox"/>	<input type="checkbox"/>	<input type="checkbox"/>	<input type="checkbox"/>	<input type="checkbox"/>	<input type="checkbox"/>	<input type="checkbox"/>						
	30 x 54 x 35-3/4	RCWT305436CDR-RNT	<input type="checkbox"/>	<input type="checkbox"/>	<input type="checkbox"/>	<input type="checkbox"/>	<input type="checkbox"/>	<input type="checkbox"/>	<input type="checkbox"/>	<input type="checkbox"/>	<input type="checkbox"/>	<input type="checkbox"/>						
	30 x 54 x 36-1/2	RCWT305436CDR-WBB	<input type="checkbox"/>	<input type="checkbox"/>	<input type="checkbox"/>	<input type="checkbox"/>	<input type="checkbox"/>	<input type="checkbox"/>	<input type="checkbox"/>	<input type="checkbox"/>	<input type="checkbox"/>	<input type="checkbox"/>						

HOW TO ORDER

- Indicate the following information on order form:
- Quantity of each item.
 - Model number, including options. See "How To Build a Model Number".
 - Any special service required.

Note: • The indicates that a choice is required.
 • The absence of the indicates that no choice is required.
 • Alpha-numeric characters in place of indicate that no other alternatives are available.

HOW TO BUILD A MODEL NUMBER

<p>A Select basic model.</p> <p>B Select power option. NP - No power WPA1 - One above-surface module w/ USB-A/C w/wire mgmt (10ft cord) WPB1 - One above-surface module w/ USB-A & Qi wireless charge w/wire mgmt (10ft cord) WPB1 - One above-surface module w/ USB-A & Qi wireless charge w/wire mgmt (10ft cord) WPB1 - One above-surface module w/ USB-A & Qi wireless charge w/wire mgmt (10ft cord) WPB1 - One above-surface module w/ USB-A & Qi wireless charge w/wire mgmt (10ft cord) See upcharge column for pricing.</p> <p>C Select power module color. P1 - Black P2 - Cool Grey</p> <p>D Select book bag hooks. NB - No book bag hook</p>	<p>E Select base color. Refer to the Product Color Options page in this price list.</p> <p>F Select top color. Refer to the Product Color Options page in this price list.</p> <p>G Select edge color. Refer to the Product Color Options page in this price list.</p> <p>H Select door color. Refer to the Product Color Options page in this price list.</p> <p>I Select door pull. S6 - Beveled pull Black S5 - Beveled pull Satin Chrome</p> <p>J Select lock option. KS - Key standard - 2 locks</p>	<p>BH - Two book bag hooks (chrome); add \$20</p> <p>NLC - No lock core - 2 locks</p> <p>K Select lock color. Refer to the Product Color Options page in this price list.</p>
--	--	--

SPECIAL SERVICES

Special Carton Marking
 With specially marked information N/C

Shipping
 Ships partially assembled, FOB Pembroke, ON K&A 0E1, freight excluded. Freight class 100.

Specifications and prices are subject to change without prior notice.

Ruckus® Worktable (Freight Excluded Pricing)



Ruckus® Worktable (Freight Excluded Pricing)

D x W x H	MODEL NUMBER											Approx. Packaged Weight	1-1/4" Laminate Top with 74P Edge (74P)	1" Phenolic Resin Top (RNT)	1-3/4" Butcher Block Wood Top (WBB)	Laminate Grade 2 add to list price	WPA1 Power Option	WPB1 Power Option	
	Basic Model	Power Option	Power Module Color	Book Bag Hook	Base Color	Top Color	Edge Color	Door Color	Pull Option	Lock Option	Lock Color								
	30 x 54 x 36	RCWT305436TOP-74P	<input type="checkbox"/>	<input type="checkbox"/>	<input type="checkbox"/>	<input type="checkbox"/>	<input type="checkbox"/>						144.90#	\$ 1711	N/A	N/A	\$ 27	\$ 496	\$ 626
	30 x 54 x 35-3/4	RCWT305436TOP-RNT	<input type="checkbox"/>	<input type="checkbox"/>	<input type="checkbox"/>	<input type="checkbox"/>							172.50#	N/A	2623	N/A	N/A	526	652
	30 x 54 x 36-1/2	RCWT305436TOP-WBB	<input type="checkbox"/>	<input type="checkbox"/>	<input type="checkbox"/>	<input type="checkbox"/>							170.30#	N/A	N/A	3005	N/A	588	715
	30 x 54 x 36	RCWT305436TDR-74P	<input type="checkbox"/>	<input type="checkbox"/>	<input type="checkbox"/>	<input type="checkbox"/>	<input type="checkbox"/>	<input type="checkbox"/>	<input type="checkbox"/>	<input type="checkbox"/>	<input type="checkbox"/>		155.90#	\$ 2041	N/A	N/A	\$ 27	\$ 496	\$ 626
	30 x 54 x 35-3/4	RCWT305436TDR-RNT	<input type="checkbox"/>	<input type="checkbox"/>	<input type="checkbox"/>	<input type="checkbox"/>	<input type="checkbox"/>	<input type="checkbox"/>	<input type="checkbox"/>	<input type="checkbox"/>	<input type="checkbox"/>		183.50#	N/A	2897	N/A	N/A	526	652
	30 x 54 x 36-1/2	RCWT305436TDR-WBB	<input type="checkbox"/>	<input type="checkbox"/>	<input type="checkbox"/>	<input type="checkbox"/>	<input type="checkbox"/>	<input type="checkbox"/>	<input type="checkbox"/>	<input type="checkbox"/>	<input type="checkbox"/>		181.30#	N/A	N/A	3284	N/A	588	715

A **B** **C** **D** **E** **F** **G** **H** **I** **J** **K**

HOW TO ORDER

Indicate the following information on order form:

- Quantity of each item.
- Model number, including options. See "How To Build a Model Number".
- Any special service required.

Note:

- The indicates that a choice is required.
- The absence of the indicates that no choice is required.
- Alpha-numeric characters in place of indicate that no other alternatives are available.

HOW TO BUILD A MODEL NUMBER

A Select basic model.

B Select power option.
NP - No power
WPA1 - One above-surface module w/ USB-A/C w/wire mgmt (10ft cord)
WPB1 - One above-surface module w/ USB-A & Qi wireless charge w/wire mgmt (10ft cord)
WPB1 - One above-surface module w/ USB-A & Qi wireless charge w/wire mgmt (10ft cord)
WPB1 - One above-surface module w/ USB-A & Qi wireless charge w/wire mgmt (10ft cord)
WPB1 - One above-surface module w/ USB-A & Qi wireless charge w/wire mgmt (10ft cord)
 See upcharge column for pricing.

C Select power module color.
P1 - Black
P2 - Cool Grey

D Select book bag hooks.
NB - No book bag hook

E Select base color. Refer to the **Product Color Options** page in this price list.

F Select top color. Refer to the **Product Color Options** page in this price list.

G Select edge color. Refer to the **Product Color Options** page in this price list.

H Select door color. Refer to the **Product Color Options** page in this price list.

I Select door pull.
S6 - Beveled pull Black
S5 - Beveled pull Satin Chrome

J Select lock option.
KS - Key standard - 2 locks

BH - Two book bag hooks (chrome); add \$20

NLC - No lock core - 2 locks

K Select lock color. Refer to the **Product Color Options** page in this price list.

SPECIAL SERVICES

Special Carton Marking
 With specially marked information N/C



Shipping
 Ships **partially assembled, FOB Pembroke, ON K8A 0E1, freight excluded.** Freight class 100.

Specifications and prices are subject to change without prior notice.

Ruckus® Worktable (Freight Excluded Pricing)



Ruckus® Worktable (Freight Excluded Pricing)

D x W x H	MODEL NUMBER											Approx. Packaged Weight	1-1/4" Laminate Top with 74P Edge (74P)	1" Phenolic Resin Top (RNT)	1-3/4" Butcher Block Wood Top (WBB)	Laminate Grade 2 add to list price	WPC2 Power Option	
	Basic Model	Power Option	Power Module Color	Book Bag Hook	Base Color	Top Color	Edge Color	Door Color	Pull Option	Lock Option	Lock Color							
 48 x 54 x 36	RCWT485436COP-74P	<input type="checkbox"/>	<input type="checkbox"/>	<input type="checkbox"/>	<input type="checkbox"/>	<input type="checkbox"/>	<input type="checkbox"/>	<input type="checkbox"/>					249.70#	\$ 2626	N/A	N/A	\$ 53	\$ 816
48 x 54 x 35-3/4	RCWT485436COP-RNT	<input type="checkbox"/>	<input type="checkbox"/>	<input type="checkbox"/>	<input type="checkbox"/>	<input type="checkbox"/>	<input type="checkbox"/>						293.00#	N/A	3835	N/A	N/A	816
48 x 54 x 36-1/2	RCWT485436COP-WBB	<input type="checkbox"/>	<input type="checkbox"/>	<input type="checkbox"/>	<input type="checkbox"/>	<input type="checkbox"/>	<input type="checkbox"/>						290.00#	N/A	N/A	4436	N/A	816
<p>RCWT</p> <p>Double-faced 2x2 Cubby Storage, Open</p> <ul style="list-style-type: none"> • Toolless removable worksurface to ease relocation • Worksurface dimensions: 48x54 • Storage base dimensions: 36x30 • Unit ships partially assembled, casters and worksurface are field installed • Shown with optional power modules WPC2 • Cubby spaces 14"Hx13.5"Wx17"D 																		
 48 x 54 x 36	RCWT485436CDR-74P	<input type="checkbox"/>	<input type="checkbox"/>	<input type="checkbox"/>	<input type="checkbox"/>	<input type="checkbox"/>	<input type="checkbox"/>	<input type="checkbox"/>	<input type="checkbox"/>	<input type="checkbox"/>	<input type="checkbox"/>	<input type="checkbox"/>	271.70#	\$ 3075	N/A	N/A	\$ 53	\$ 816
48 x 54 x 35-3/4	RCWT485436CDR-RNT	<input type="checkbox"/>	<input type="checkbox"/>	<input type="checkbox"/>	<input type="checkbox"/>	<input type="checkbox"/>	<input type="checkbox"/>	<input type="checkbox"/>	<input type="checkbox"/>	<input type="checkbox"/>	<input type="checkbox"/>	<input type="checkbox"/>	315.00#	N/A	4300	N/A	N/A	816
48 x 54 x 36-1/2	RCWT485436CDR-WBB	<input type="checkbox"/>	<input type="checkbox"/>	<input type="checkbox"/>	<input type="checkbox"/>	<input type="checkbox"/>	<input type="checkbox"/>	<input type="checkbox"/>	<input type="checkbox"/>	<input type="checkbox"/>	<input type="checkbox"/>	<input type="checkbox"/>	312.00#	N/A	N/A	4966	N/A	816
<p>RCWT</p> <p>Double-faced 2x2 Cubby Storage, with Doors</p> <ul style="list-style-type: none"> • Toolless removable worksurface to ease relocation • Worksurface dimensions: 48x54 • Storage base dimensions: 36x30 • Unit ships partially assembled, casters and worksurface are field installed • Shown with optional power modules WPC2 • Cubby spaces 14"Hx13.5"Wx17"D • Secure locking doors 																		
	A	B	C	D	E	F	G	H	I	J	K							

HOW TO ORDER

- Indicate the following information on order form:
- Quantity of each item.
 - Model number, including options. See "How To Build a Model Number".
 - Any special service required.

Note: • The indicates that a choice is required.

- The absence of the indicates that no choice is required.
- Alpha-numeric characters in place of indicate that no other alternatives are available.

HOW TO BUILD A MODEL NUMBER

- A** Select basic model.
- B** Select power option.
NP - No power
WPC2 - Two under-surface modules w/ USB-A/C and wire mgmt (10ft cords)
 See upcharge column for pricing.
- C** Select power module color.
P1 - Black
P2 - Cool Grey
- D** Select book bag hooks.
NB - No book bag hook
BH - Four book bag hooks (Chrome); add \$39
- E** Select base color.
 Refer to the **Product Color Options** page in this price list.
- F** Select top color.
 Refer to the **Product Color Options** page in this price list.

- price list.
- G** Select edge color.
 Refer to the **Product Color Options** page in this price list.
 - H** Select door color.
 Refer to the **Product Color Options** page in this price list.
 - I** Select door pull.
S6 - Beveled pull Black
S5 - Beveled pull Satin Chrome
 - J** Select lock option.
KS - Key standard - 4 locks
NLC - No lock core - 4 locks
 - K** Select lock color.
 Refer to the **Product Color Options** page in this price list.

SPECIAL SERVICES

Special Carton Marking
 With specially marked information N/C



Shipping
 Ships **partially assembled, FOB Pembroke, ON K8A 0E1, freight excluded.** Freight class 100.

Specifications and prices are subject to change without prior notice.

Ruckus® Worktable (Freight Excluded Pricing)



Ruckus® Worktable (Freight Excluded Pricing)

D x W x H	MODEL NUMBER											Approx. Packaged Weight	1-1/4" Laminate Top with 74P Edge (74P)	1" Phenolic Resin Top (RNT)	1-3/4" Butcher Block Wood Top (WBB)	Laminate Grade 2 add to list price	WPC2 Power Option	
	Basic Model	Power Option	Power Module Color	Book Bag Hook	Base Color	Top Color	Edge Color	Door Color	Pull Option	Lock Option	Lock Color							
 RCWT Double-faced Tote Storage, (12) 6" & (4) 3" Totes, Open • Toolless removable worksurface to ease relocation • Worksurface dimensions: 48x54 • Storage base dimensions: 36x30 • Unit ships partially assembled, casters and worksurface are field installed • Shown with optional power modules WPC2 • Totes included are translucent with no lid	48 x 54 x 36	RCWT485436TOP-74P	<input type="checkbox"/> <input type="checkbox"/> <input type="checkbox"/> <input type="checkbox"/>	<input type="checkbox"/>	<input type="checkbox"/>	<input type="checkbox"/>	<input type="checkbox"/>	<input type="checkbox"/>					270.10#	\$ 2871	N/A	N/A	\$ 53	\$ 816
	48 x 54 x 35-3/4	RCWT485436TOP-RNT	<input type="checkbox"/> <input type="checkbox"/> <input type="checkbox"/> <input type="checkbox"/>	<input type="checkbox"/>	<input type="checkbox"/>	<input type="checkbox"/>	<input type="checkbox"/>						313.40#	N/A	4121	N/A	N/A	816
	48 x 54 x 36-1/2	RCWT485436TOP-WBB	<input type="checkbox"/> <input type="checkbox"/> <input type="checkbox"/> <input type="checkbox"/>	<input type="checkbox"/>	<input type="checkbox"/>	<input type="checkbox"/>	<input type="checkbox"/>						310.40#	N/A	N/A	4731	N/A	816
 RCWT Double-faced Tote Storage, (12) 6" & (4) 3" Totes, With Doors • Toolless removable worksurface to ease relocation • Worksurface dimensions: 48x54 • Storage base dimensions: 36x30 • Unit ships partially assembled, casters and worksurface are field installed • Shown with optional power modules WPC2 • Totes included are translucent with no lid • Secure locking doors	48 x 54 x 36	RCWT485436TDR-74P	<input type="checkbox"/> <input type="checkbox"/> <input type="checkbox"/> <input type="checkbox"/>	<input type="checkbox"/>	<input type="checkbox"/>	<input type="checkbox"/>	<input type="checkbox"/>	<input type="checkbox"/>	<input type="checkbox"/>	<input type="checkbox"/>	<input type="checkbox"/>	<input type="checkbox"/>	292.10#	\$ 3364	N/A	N/A	\$ 53	\$ 816
	48 x 54 x 35-3/4	RCWT485436TDR-RNT	<input type="checkbox"/> <input type="checkbox"/> <input type="checkbox"/> <input type="checkbox"/>	<input type="checkbox"/>	<input type="checkbox"/>	<input type="checkbox"/>	<input type="checkbox"/>	<input type="checkbox"/>	<input type="checkbox"/>	<input type="checkbox"/>	<input type="checkbox"/>	<input type="checkbox"/>	335.40#	N/A	4593	N/A	N/A	816
	48 x 54 x 36-1/2	RCWT485436TDR-WBB	<input type="checkbox"/> <input type="checkbox"/> <input type="checkbox"/> <input type="checkbox"/>	<input type="checkbox"/>	<input type="checkbox"/>	<input type="checkbox"/>	<input type="checkbox"/>	<input type="checkbox"/>	<input type="checkbox"/>	<input type="checkbox"/>	<input type="checkbox"/>	<input type="checkbox"/>	332.40#	N/A	N/A	5273	N/A	816
			A	B	C	D	E	F	G	H	I	J	K					

HOW TO ORDER

- Indicate the following information on order form:
- Quantity of each item.
 - Model number, including options. See "How To Build a Model Number".
 - Any special service required.

Note: • The indicates that a choice is required.
 • The absence of the indicates that no choice is required.
 • Alpha-numeric characters in place of indicate that no other alternatives are available.

HOW TO BUILD A MODEL NUMBER

- A** Select basic model.
- B** Select power option.
 NP - No power
 WPC2 - Two under-surface modules w/ USB-A/C and wire mgmt (10ft cords)
 See upcharge column for pricing.
- C** Select power module color.
 P1 - Black
 P2 - Cool Grey
- D** Select book bag hooks.
 NB - No book bag hook
 BH - Four book bag hooks (Chrome); add \$39
- E** Select base color.
 Refer to the **Product Color Options** page in this price list.
- F** Select top color.
 Refer to the **Product Color Options** page in this price list.

- G** Select edge color.
 Refer to the **Product Color Options** page in this price list.
- H** Select door color.
 Refer to the **Product Color Options** page in this price list.
- I** Select door pull.
 S6 - Beveled pull Black
 S5 - Beveled pull Satin Chrome
- J** Select lock option.
 KS - Key standard - 4 locks
 NLC - No lock core - 4 locks
- K** Select lock color.
 Refer to the **Product Color Options** page in this price list.

SPECIAL SERVICES

Special Carton Marking
 With specially marked information N/C

Shipping
 Ships **partially assembled, FOB Pembroke, ON K8A 0E1, freight excluded.** Freight class 100.

Specifications and prices are subject to change without prior notice.

Ruckus® Worktable (Freight Excluded Pricing)



Ruckus® Worktable (Freight Excluded Pricing)

MODEL	D x W x H	MODEL NUMBER							Approx. Packaged Weight	1-1/4" Laminate Top with 74P Edge (74P)	1" Phenolic Resin Top (RNT)	1-3/4" Butcher Block Wood Top (WBB)	Laminate Grade 2 add to list price	WPC2 Power Option
		Basic Model	Power Option	Power Module Color	Book Bag Hook	Base Color	Top Color	Edge Color						
Double-faced 2x2 Cubby & Tote Storage, (6) 6" & (2) 3" Totes, Open • Toolless removable worksurface to ease relocation • Worksurface dimensions: 48x54 • Storage base dimensions: 36x30 • Unit ships partially assembled, casters and worksurface are field installed • Shown with optional power modules WPC2 • Totes included are translucent with no lid • Cubby spaces 14"Hx13.5"Wx17"D	48 x 54 x 36	RCWT485436CTOP-74P	<input type="checkbox"/> <input type="checkbox"/> <input type="checkbox"/> <input type="checkbox"/>	<input type="checkbox"/> <input type="checkbox"/>	<input type="checkbox"/> <input type="checkbox"/>	<input type="checkbox"/> <input type="checkbox"/>	<input type="checkbox"/> <input type="checkbox"/>	<input type="checkbox"/> <input type="checkbox"/>	259.90#	\$ 2789	N/A	N/A	\$ 53	\$ 816
	48 x 54 x 35-3/4	RCWT485436CTOP-RNT	<input type="checkbox"/> <input type="checkbox"/> <input type="checkbox"/> <input type="checkbox"/>	<input type="checkbox"/> <input type="checkbox"/>	<input type="checkbox"/> <input type="checkbox"/>	<input type="checkbox"/> <input type="checkbox"/>	<input type="checkbox"/> <input type="checkbox"/>	<input type="checkbox"/> <input type="checkbox"/>	303.20#	N/A	3951	N/A	N/A	816
	48 x 54 x 36-1/2	RCWT485436CTOP-WBB	<input type="checkbox"/> <input type="checkbox"/> <input type="checkbox"/> <input type="checkbox"/>	<input type="checkbox"/> <input type="checkbox"/>	<input type="checkbox"/> <input type="checkbox"/>	<input type="checkbox"/> <input type="checkbox"/>	<input type="checkbox"/> <input type="checkbox"/>	<input type="checkbox"/> <input type="checkbox"/>	300.20#	N/A	N/A	4613	N/A	816
			A	B	C	D	E	F	G					

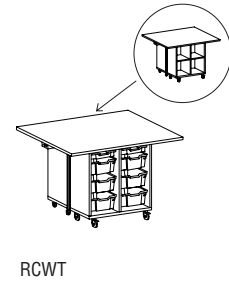

HOW TO ORDER

- Indicate the following information on order form:
- Quantity of each item.
 - Model number, including options. See "How To Build a Model Number".
 - Any special service required.

Note: • The indicates that a choice is required.
 • The absence of the indicates that no choice is required.
 • Alpha-numeric characters in place of indicate that no other alternatives are available.

HOW TO BUILD A MODEL NUMBER

- A** Select basic model.
- B** Select power option.
NP - No power
WPC2 - Two under-surface modules w/ USB-A/C and wire mgmt (10ft cords)
 See upcharge column for pricing.
- C** Select power module color.
P1 - Black
P2 - Cool Grey
- D** Select book bag hooks.
NB - No book bag hook
BH - Four book bag hooks (Chrome); add \$39
- E** Select base color.
 Refer to the **Product Color Options** page in this price list.
- F** Select top color.
 Refer to the **Product Color Options** page in this

price list.

G Select edge color.
 Refer to the **Product Color Options** page in this price list.

SPECIAL SERVICES

Special Carton Marking
 With specially marked information N/C

Shipping
 Ships **partially assembled, FOB Pembroke, ON K8A 0E1, freight excluded.** Freight class 100.

Specifications and prices are subject to change without prior notice.

Ruckus® Worktable (Freight Excluded Pricing)



Ruckus® Worktable (Freight Excluded Pricing)

D x W x H	MODEL NUMBER											Approx. Packaged Weight	1-1/4" Laminate Top with 74P Edge (74P)	1" Phenolic Resin Top (RNT)	1-3/4" Butcher Block Wood Top (WBB)	Laminate Grade 2 add to list price	WPC2 Power Option
	Basic Model	Power Option	Power Module Color	Book Bag Hook	Base Color	Top Color	Edge Color	Door Color	Pull Option	Lock Option	Lock Color						
48 x 54 x 36	RCWT485436CTDR-74P	<input type="checkbox"/> <input type="checkbox"/> <input type="checkbox"/> <input type="checkbox"/>	<input type="checkbox"/>	<input type="checkbox"/>	<input type="checkbox"/>	<input type="checkbox"/>	<input type="checkbox"/>	<input type="checkbox"/>	<input type="checkbox"/>	<input type="checkbox"/>	<input type="checkbox"/>	281.90#	\$ 3285	N/A	N/A	\$ 53	\$ 816
48 x 54 x 35-3/4	RCWT485436CTDR-RNT	<input type="checkbox"/> <input type="checkbox"/> <input type="checkbox"/> <input type="checkbox"/>	<input type="checkbox"/>	<input type="checkbox"/>	<input type="checkbox"/>	<input type="checkbox"/>	<input type="checkbox"/>	<input type="checkbox"/>	<input type="checkbox"/>	<input type="checkbox"/>	<input type="checkbox"/>	303.20#	N/A	4416	N/A	N/A	816
48 x 54 x 36-1/2	RCWT485436CTDR-WBB	<input type="checkbox"/> <input type="checkbox"/> <input type="checkbox"/> <input type="checkbox"/>	<input type="checkbox"/>	<input type="checkbox"/>	<input type="checkbox"/>	<input type="checkbox"/>	<input type="checkbox"/>	<input type="checkbox"/>	<input type="checkbox"/>	<input type="checkbox"/>	<input type="checkbox"/>	322.20#	N/A	N/A	5155	N/A	816

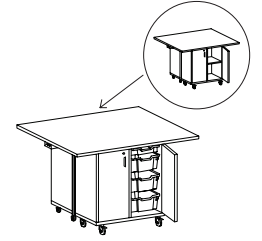

RCWT

Double-faced 2x2 Cubby & Tote Storage, (6) 6" & (2) 3" Totes, With Doors

- Toolless removable worksurface to ease relocation
- Worksurface dimensions: 48x54
- Storage base dimensions: 36x30
- Unit ships partially assembled, casters and worksurface are field installed
- Shown with optional power modules WPC2
- Totes included are translucent with no lid
- Cubby spaces 14"Hx13.5"Wx17"D
- Secure locking doors

A
B
C
D
E
F
G
H
I
J
K

HOW TO ORDER

- Indicate the following information on order form:
- Quantity of each item.
 - Model number, including options. See "How To Build a Model Number".
 - Any special service required.

Note: • The indicates that a choice is required.
 • The absence of the indicates that no choice is required.
 • Alpha-numeric characters in place of indicate that no other alternatives are available.

HOW TO BUILD A MODEL NUMBER

- | | |
|--|---|
| <p>A Select basic model.</p> <p>B Select power option.
 NP - No power
 WPC2 - Two under-surface modules w/ USB-A/C and wire mgmt (10ft cords)
 See upcharge column for pricing.</p> <p>C Select power module color.
 P1 - Black
 P2 - Cool Grey</p> <p>D Select book bag hooks.
 NB - No book bag hook
 BH - Four book bag hooks (Chrome); add \$39</p> <p>E Select base color.
 Refer to the Product Color Options page in this price list.</p> <p>F Select top color.
 Refer to the Product Color Options page in this</p> | <p>price list.</p> <p>G Select edge color.
 Refer to the Product Color Options page in this price list.</p> <p>H Select door color.
 Refer to the Product Color Options page in this price list.</p> <p>I Select door pull.
 S6 - Beveled pull Black
 S5 - Beveled pull Satin Chrome</p> <p>J Select lock option.
 KS - Key standard - 4 locks
 NLC - No lock core - 4 locks</p> <p>K Select lock color.
 Refer to the Product Color Options page in this price list.</p> |
|--|---|

SPECIAL SERVICES

Special Carton Marking
 With specially marked information N/C

Shipping
 Ships **partially assembled, FOB Pembroke, ON K8A 0E1, freight excluded.** Freight class 100.

Specifications and prices are subject to change without prior notice.



D x W x H	MODEL NUMBER											Approx. Packaged Weight	1-1/4" Laminate Top with 74P Edge (74P)	1" Phenolic Resin Top (RNT)	Laminate Grade 2 add to list price	WPC2 Power Option	
	Basic Model	Power Option	Power Module Color	Book Bag Hook	Base Color	Top Color	Edge Color	Door Color	Pull Option	Lock Option	Lock Color						
60 x 54 x 36	RCWT605436COP-74P	<input type="checkbox"/> <input type="checkbox"/> <input type="checkbox"/> <input type="checkbox"/>	<input type="checkbox"/> <input type="checkbox"/>	<input type="checkbox"/> <input type="checkbox"/>	<input type="checkbox"/> <input type="checkbox"/>	<input type="checkbox"/> <input type="checkbox"/>	<input type="checkbox"/> <input type="checkbox"/>	<input type="checkbox"/> <input type="checkbox"/>					270.20#	\$ 2908	N/A	\$ 53	\$ 816
60 x 54 x 35-3/4	RCWT605436COP-RNT	<input type="checkbox"/> <input type="checkbox"/> <input type="checkbox"/> <input type="checkbox"/>	<input type="checkbox"/> <input type="checkbox"/>	<input type="checkbox"/> <input type="checkbox"/>	<input type="checkbox"/> <input type="checkbox"/>	<input type="checkbox"/> <input type="checkbox"/>	<input type="checkbox"/> <input type="checkbox"/>						324.90#	N/A	4229	N/A	816
60 x 54 x 36	RCWT605436CDR-74P	<input type="checkbox"/> <input type="checkbox"/> <input type="checkbox"/> <input type="checkbox"/>	<input type="checkbox"/> <input type="checkbox"/>	<input type="checkbox"/> <input type="checkbox"/>	<input type="checkbox"/> <input type="checkbox"/>	<input type="checkbox"/> <input type="checkbox"/>	<input type="checkbox"/> <input type="checkbox"/>	<input type="checkbox"/> <input type="checkbox"/>	<input type="checkbox"/> <input type="checkbox"/>	<input type="checkbox"/> <input type="checkbox"/>	<input type="checkbox"/> <input type="checkbox"/>	<input type="checkbox"/> <input type="checkbox"/>	292.20#	\$ 3406	N/A	\$ 53	\$ 816
60 x 54 x 35-3/4	RCWT605436CDR-RNT	<input type="checkbox"/> <input type="checkbox"/> <input type="checkbox"/> <input type="checkbox"/>	<input type="checkbox"/> <input type="checkbox"/>	<input type="checkbox"/> <input type="checkbox"/>	<input type="checkbox"/> <input type="checkbox"/>	<input type="checkbox"/> <input type="checkbox"/>	<input type="checkbox"/> <input type="checkbox"/>	<input type="checkbox"/> <input type="checkbox"/>	<input type="checkbox"/> <input type="checkbox"/>	<input type="checkbox"/> <input type="checkbox"/>	<input type="checkbox"/> <input type="checkbox"/>	<input type="checkbox"/> <input type="checkbox"/>	346.90#	N/A	4707	N/A	816



RCWT
Double-faced 2x2 Cubby Storage, Open

- Toolless removable worksurface to ease relocation
- Worksurface dimensions: 60x54
- Storage base dimensions: 36x30
- Unit ships partially assembled, casters and worksurface are field installed
- Shown with optional power modules WPC2
- Cubby spaces 14"Hx13.5"Wx17"D

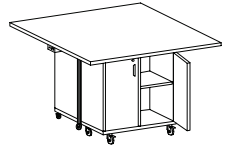

RCWT
Double-faced 2x2 Cubby Storage, with Doors

- Toolless removable worksurface to ease relocation
- Worksurface dimensions: 60x54
- Storage base dimensions: 36x30
- Unit ships partially assembled, casters and worksurface are field installed
- Shown with optional power modules WPC2
- Cubby spaces 14"Hx13.5"Wx17"D
- Secure locking doors

A B C D E F G H I J K

HOW TO ORDER

Indicate the following information on order form:
 1. Quantity of each item.
 2. Model number, including options. See "How To Build a Model Number".
 3. Any special service required.

Note: • The indicates that a choice is required.
 • The absence of the indicates that no choice is required.
 • Alpha-numeric characters in place of indicate that no other alternatives are available.

HOW TO BUILD A MODEL NUMBER

- A** Select basic model.
- B** Select power option.
 NP - No power
 WPC2 - Two under-surface modules w/ USB-A/C and wire mgmt (10ft cords)
 See upcharge column for pricing.
- C** Select power module color.
 P1 - Black
 P2 - Cool Grey
- D** Select book bag hooks.
 NB - No book bag hook
 BH - Eight book bag hooks (Chrome); add \$78
- E** Select base color.
 Refer to the **Product Color Options** page in this price list.
- F** Select top color.
 Refer to the **Product Color Options** page in this

- price list.
- G** Select edge color.
 Refer to the **Product Color Options** page in this price list.
- H** Select door color.
 Refer to the **Product Color Options** page in this price list.
- I** Select door pull.
 S6 - Beveled pull Black
 S5 - Beveled pull Satin Chrome
- J** Select lock option.
 KS - Key standard - 4 locks
 NLC - No lock core - 4 locks
- K** Select lock color.
 Refer to the **Product Color Options** page in this price list.

SPECIAL SERVICES

Special Carton Marking
 With specially marked information N/C

Shipping
 Ships partially assembled, FOB Pembroke, ON K8A 0E1, freight excluded. Freight class 100.

Specifications and prices are subject to change without prior notice.



D x W x H	MODEL NUMBER											Approx. Packaged Weight	1-1/4" Laminate Top with 74P Edge (74P)	1" Phenolic Resin Top (RNT)	Laminate Grade 2 add to list price	WPC2 Power Option	
	Basic Model	Power Option	Power Module Color	Book Bag Hook	Base Color	Top Color	Edge Color	Door Color	Pull Option	Lock Option	Lock Color						
60 x 54 x 36	RCWT605436TOP-74P	<input type="checkbox"/> <input type="checkbox"/> <input type="checkbox"/> <input type="checkbox"/>	<input type="checkbox"/> <input type="checkbox"/>	<input type="checkbox"/> <input type="checkbox"/>	<input type="checkbox"/> <input type="checkbox"/>	<input type="checkbox"/> <input type="checkbox"/>	<input type="checkbox"/> <input type="checkbox"/>	<input type="checkbox"/> <input type="checkbox"/>	<input type="checkbox"/> <input type="checkbox"/>	<input type="checkbox"/> <input type="checkbox"/>	<input type="checkbox"/> <input type="checkbox"/>	<input type="checkbox"/> <input type="checkbox"/>	290.60#	\$ 3157	N/A	\$ 53	\$ 816
60 x 54 x 35-3/4	RCWT605436TOP-RNT	<input type="checkbox"/> <input type="checkbox"/> <input type="checkbox"/> <input type="checkbox"/>	<input type="checkbox"/> <input type="checkbox"/>	<input type="checkbox"/> <input type="checkbox"/>	<input type="checkbox"/> <input type="checkbox"/>	<input type="checkbox"/> <input type="checkbox"/>	<input type="checkbox"/> <input type="checkbox"/>	<input type="checkbox"/> <input type="checkbox"/>	<input type="checkbox"/> <input type="checkbox"/>	<input type="checkbox"/> <input type="checkbox"/>	<input type="checkbox"/> <input type="checkbox"/>	<input type="checkbox"/> <input type="checkbox"/>	345.30#	N/A	4530	N/A	816
<p>RCWT Double-faced Tote Storage, (12) 6" & (4) 3" Totes, Open</p> <ul style="list-style-type: none"> • Toolless removable worksurface to ease relocation • Worksurface dimensions: 60x54 • Storage base dimensions: 36x30 • Unit ships partially assembled, casters and worksurface are field installed • Shown with optional power modules WPC2 • Totes included are translucent with no lid 																	
60 x 54 x 36	RCWT605436TDR-74P	<input type="checkbox"/> <input type="checkbox"/> <input type="checkbox"/> <input type="checkbox"/>	<input type="checkbox"/> <input type="checkbox"/>	<input type="checkbox"/> <input type="checkbox"/>	<input type="checkbox"/> <input type="checkbox"/>	<input type="checkbox"/> <input type="checkbox"/>	<input type="checkbox"/> <input type="checkbox"/>	<input type="checkbox"/> <input type="checkbox"/>	<input type="checkbox"/> <input type="checkbox"/>	<input type="checkbox"/> <input type="checkbox"/>	<input type="checkbox"/> <input type="checkbox"/>	<input type="checkbox"/> <input type="checkbox"/>	312.60#	\$ 3656	N/A	\$ 53	\$ 816
60 x 54 x 35-3/4	RCWT605436TDR-RNT	<input type="checkbox"/> <input type="checkbox"/> <input type="checkbox"/> <input type="checkbox"/>	<input type="checkbox"/> <input type="checkbox"/>	<input type="checkbox"/> <input type="checkbox"/>	<input type="checkbox"/> <input type="checkbox"/>	<input type="checkbox"/> <input type="checkbox"/>	<input type="checkbox"/> <input type="checkbox"/>	<input type="checkbox"/> <input type="checkbox"/>	<input type="checkbox"/> <input type="checkbox"/>	<input type="checkbox"/> <input type="checkbox"/>	<input type="checkbox"/> <input type="checkbox"/>	<input type="checkbox"/> <input type="checkbox"/>	367.30#	N/A	5015	N/A	816
<p>RCWT Double-faced Tote Storage, (12) 6" & (4) 3" Totes, With Doors</p> <ul style="list-style-type: none"> • Toolless removable worksurface to ease relocation • Worksurface dimensions: 60x54 • Storage base dimensions: 36x30 • Unit ships partially assembled, casters and worksurface are field installed • Shown with optional power modules WPC2 • Totes included are translucent with no lid • Secure locking doors 																	
		A	B	C	D	E	F	G	H	I	J	K					

HOW TO ORDER

Indicate the following information on order form:
 1. Quantity of each item.
 2. Model number, including options. See "How To Build a Model Number".
 3. Any special service required.

Note: • The indicates that a choice is required.
 • The absence of the indicates that no choice is required.
 • Alpha-numeric characters in place of indicate that no other alternatives are available.

HOW TO BUILD A MODEL NUMBER

- A** Select basic model.
- B** Select power option.
NP - No power
WPC2 - Two under-surface modules w/ USB-A/C and wire mgmt (10ft cords)
 See upcharge column for pricing.
- C** Select power module color.
P1 - Black
P2 - Cool Grey
- D** Select book bag hooks.
NB - No book bag hook
BH - Eight book bag hooks (Chrome); add \$78
- E** Select base color.
 Refer to the **Product Color Options** page in this price list.
- F** Select top color.
 Refer to the **Product Color Options** page in this price list.

- price list.
- G** Select edge color.
 Refer to the **Product Color Options** page in this price list.
- H** Select door color.
 Refer to the **Product Color Options** page in this price list.
- I** Select door pull.
S6 - Beveled pull Black
S5 - Beveled pull Satin Chrome
- J** Select lock option.
KS - Key standard - 4 locks
NLC - No lock core - 4 locks
- K** Select lock color.
 Refer to the **Product Color Options** page in this price list.

SPECIAL SERVICES

Special Carton Marking
 With specially marked information N/C

Shipping
 Ships **partially assembled, FOB Pembroke, ON K8A 0E1, freight excluded.** Freight class 100.

Specifications and prices are subject to change without prior notice.



MODEL	D x W x H	MODEL NUMBER							Approx. Packaged Weight	1-1/4" Laminate Top with 74P Edge (74P)	1" Phenolic Resin Top (RNT)	Laminate Grade 2 add to list price	WPC2 Power Option
		Basic Model	Power Option	Power Module Color	Book Bag Hook	Base Color	Top Color	Edge Color					
Double-faced 2x2 Cubby and Tote Storage, (6) 6" & (2) 3" Totes, Open • Toolless removable worksurface to ease relocation • Worksurface dimensions: 60x54 • Storage base dimensions: 36x30 • Unit ships partially assembled, casters and worksurface are field installed • Shown with optional power modules WPC2 • Totes included are translucent with no lid • Cubby spaces 14"Hx13.5"Wx17"D	60 x 54 x 36	RCWT605436CTOP-74P	<input type="checkbox"/> <input type="checkbox"/> <input type="checkbox"/> <input type="checkbox"/>	<input type="checkbox"/> <input type="checkbox"/>	<input type="checkbox"/> <input type="checkbox"/>	<input type="checkbox"/> <input type="checkbox"/>	<input type="checkbox"/> <input type="checkbox"/>	<input type="checkbox"/> <input type="checkbox"/>	280.40#	\$ 3034	N/A	\$ 53	\$ 816
	60 x 54 x 35-3/4	RCWT605436CTOP-RNT	<input type="checkbox"/> <input type="checkbox"/> <input type="checkbox"/> <input type="checkbox"/>	<input type="checkbox"/> <input type="checkbox"/>	<input type="checkbox"/> <input type="checkbox"/>	<input type="checkbox"/> <input type="checkbox"/>	<input type="checkbox"/> <input type="checkbox"/>	<input type="checkbox"/> <input type="checkbox"/>	335.10#	N/A	4348	N/A	816

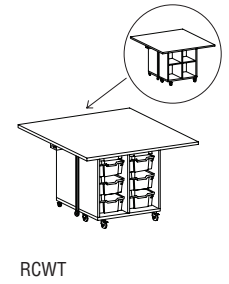

RCWT

HOW TO ORDER

- Indicate the following information on order form:
- Quantity of each item.
 - Model number, including options. See "How To Build a Model Number".
 - Any special service required.

Note: • The indicates that a choice is required.
 • The absence of the indicates that no choice is required.
 • Alpha-numeric characters in place of indicate that no other alternatives are available.

HOW TO BUILD A MODEL NUMBER

- A** Select basic model.
- B** Select power option.
 NP - No power
 WPC2 - Two under-surface modules w/ USB-A/C and wire mgmt (10ft cords)
 See upcharge column for pricing.
- C** Select power module color.
 P1 - Black
 P2 - Cool Grey
- D** Select book bag hooks.
 NB - No book bag hook
 BH - Eight book bag hooks (Chrome); add \$78
- E** Select base color.
 Refer to the **Product Color Options** page in this price list.
- F** Select top color.
 Refer to the **Product Color Options** page in this

price list.

G Select edge color.
 Refer to the **Product Color Options** page in this price list.

SPECIAL SERVICES

Special Carton Marking



With specially marked information N/C

Shipping

Ships **partially assembled, FOB Pembroke, ON K8A 0E1, freight excluded.** Freight class 100.

Specifications and prices are subject to change without prior notice.

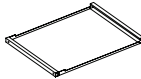
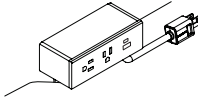
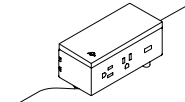
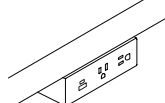

MODEL	MODEL NUMBER			Approx. Packaged Weight	Freight Excluded Pricing
	Basic Model	Paint Color	Finish		
 Tote Storage Removeable Steel Shelf with Rail Set RCKA	RKATSSHELF	<input type="checkbox"/>	<input type="checkbox"/>	4.50#	\$ 48
 Above-surface power module w/ USB charging, 10' cord and wire management RCWA	RCWAPA1	<input type="checkbox"/>	<input type="checkbox"/>	3.00#	\$ 496
 Above-surface power module w/ USB and Qi wireless charging, 10' cord and wire management RCWA	RCWAPB1	<input type="checkbox"/>	<input type="checkbox"/>	3.00#	\$ 626
 Undersurface power module w/ USB charging, 10' cord and wire management RCWA	RCWAPC1	<input type="checkbox"/>	<input type="checkbox"/>	3.00#	\$ 466
 Ruckus Book Bag Hook RUA01	RCWABBH1			3.00#	\$ 11

A **B** **C**

HOW TO ORDER

- Indicate the following information on order form:
- Quantity of each item.
 - Model number, including options. See "How To Build a Model Number".
 - Any special service required.

Note:

- The indicates that a choice is required.
- The absence of the indicates that no choice is required.
- Alpha-numeric characters in place of indicate that no other alternatives are available.

HOW TO BUILD A MODEL NUMBER

- A** Select basic model.
- B** Select paint color. Refer to the **Product Color Options** page in this price list.
- C** Select finish. Refer to the **Product Color Options** page in this price list.

SPECIAL SERVICES

Special Carton Marking



With specially marked information N/C

Shipping

Ships assembled, FOB Pembroke, ON K8A 0E1, freight excluded. Freight class 100.

Specifications and prices are subject to change without prior notice.



MODEL	W x D x H	MODEL NUMBER					Approx. Packaged Weight	Freight Excluded Pricing	Laminate Grade 2 add to list price
		Basic Model	Base	Top Color	Edge Color	Shell Color			
 <p>Single-Face Bookcase Unit with Adjustable Shelves</p> <ul style="list-style-type: none"> Laminate top (1-1/4" with 74P edge) Single sided storage 3 compartments per side (3 total) Unit ships assembled; glides/casters are field installed Shelves adjust in 1" increments, without tools 	36 x 18 x 36"	RKB361836	<input type="checkbox"/>	<input type="checkbox"/>	<input type="checkbox"/>	<input type="checkbox"/>	81.7#	\$ 1108	\$ 19
	36 x 18 x 42"	RKB361842	<input type="checkbox"/>	<input type="checkbox"/>	<input type="checkbox"/>	<input type="checkbox"/>	89.7#	1155	19
 <p>Double-Face Bookcase Unit with Adjustable Shelves</p> <ul style="list-style-type: none"> Laminate top (1-1/4" with 74P edge) Dual sided storage 3 compartments per side (6 total) Unit ships assembled; glides/casters are field installed Shelves adjust in 1" increments, without tools 	36 x 24 x 36"	RKB362436	<input type="checkbox"/>	<input type="checkbox"/>	<input type="checkbox"/>	<input type="checkbox"/>	161.0#	\$ 1271	\$ 19
	36 x 24 x 42"	RKB362442	<input type="checkbox"/>	<input type="checkbox"/>	<input type="checkbox"/>	<input type="checkbox"/>	170.6#	1337	19

A B C D E

HOW TO ORDER

- Indicate the following information on order form:
- Quantity of each item.
 - Model number, including options. See "How To Build a Model Number".
 - Any special service required.

Note:

- The indicates that a choice is required.
- The absence of the indicates that no choice is required.
- Alpha-numeric characters in place of indicate that no other alternatives are available.

HOW TO BUILD A MODEL NUMBER

- A** Select basic model.
- B** Select base option.

4CW	- 4 black casters
4GB	- 4 black glides
- C** Select top laminate surface. Refer to the **Product Color Options** page in this price list.
- D** Select edge color. Refer to the **Product Color Options** page in this price list.
- E** Select shell color. Refer to the **Product Color Options** page in this price list.

FINISH INFORMATION

Additional Laminate Offering
 KI offers laminates beyond those offered in the standard offering. Laminates that are currently available in the program can be viewed in KI product specification tools. Requests to add laminates to the program can be submitted via the product modification request process. Please note, requests to add laminates to the program must include the laminate manufacturer's name, color/pattern number, and finish code. Edge options are limited to standard edge colors. If a matching edge is required, this will need to be requested through the product modification request process and may be subject to additional costs. Due to varying manufacturing processes and quality issues with some laminates, some requests may be denied. Extended lead times and minimum order quantities may apply on orders containing special laminates. Contact the product modification team for questions or additional information regarding special laminates and pricing.

SPECIAL SERVICES



Special Carton Marking

With specially marked information N/C

Shipping
 Ships assembled, FOB Pembroke, ON K8A 0E1, freight excluded. Freight class 100.

Specifications and prices are subject to change without prior notice.

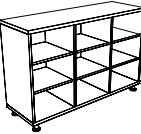

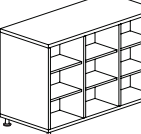
MODEL	W x D x H	MODEL NUMBER					Approx. Packaged Weight	Freight Excluded Pricing
		Basic Model	Base	Top Color	Edge Color	Shell Color		
 <p>Single-Face Cubbies 2x3-Open Units • Laminate top (1-1/4" with 74P edge) • Single sided storage (6 total compartments) • Unit ships assembled; glides/casters are field installed</p>	36 x 18 x 36"	RKC361836OP	<input type="checkbox"/>	<input type="checkbox"/>	<input type="checkbox"/>	<input type="checkbox"/>	96.6#	\$ 1343
	36 x 18 x 42"	RKC361842OP	<input type="checkbox"/>	<input type="checkbox"/>	<input type="checkbox"/>	<input type="checkbox"/>	107.3#	1354
RCKC								
 <p>Single-Face Cubbies 3x3-Open Units • Laminate top (1-1/4" with 74P edge) • Single sided storage (9 total compartments) • Unit ships assembled; glides/casters are field installed</p>	54 x 18 x 36"	RKC541836OP	<input type="checkbox"/>	<input type="checkbox"/>	<input type="checkbox"/>	<input type="checkbox"/>	138.4#	\$ 1700
	54 x 18 x 42"	RKC541842OP	<input type="checkbox"/>	<input type="checkbox"/>	<input type="checkbox"/>	<input type="checkbox"/>	150.0#	1757
RCKC								
 <p>Double-Face Cubbies 2x3-Open Units • Laminate top (1-1/4" with 74P edge) • Dual sided storage (12 total compartments) • Unit ships assembled; glides/casters are field installed</p>	36 x 24 x 36"	RKC362436OP	<input type="checkbox"/>	<input type="checkbox"/>	<input type="checkbox"/>	<input type="checkbox"/>	181.4#	\$ 1492
	36 x 24 x 42"	RKC362442OP	<input type="checkbox"/>	<input type="checkbox"/>	<input type="checkbox"/>	<input type="checkbox"/>	194.6#	1545
RCKC								
 <p>Double-Face Cubbies 3x3-Open Units • Laminate top (1-1/4" with 74P edge) • Dual sided storage (18 total compartments) • Unit ships assembled; glides/casters are field installed</p>	54 x 24 x 36"	RKC542436OP	<input type="checkbox"/>	<input type="checkbox"/>	<input type="checkbox"/>	<input type="checkbox"/>	235.2#	\$ 1943
	54 x 24 x 42"	RKC542442OP	<input type="checkbox"/>	<input type="checkbox"/>	<input type="checkbox"/>	<input type="checkbox"/>	253.1#	2013
RCKC								

A **B** **C** **D** **E**

HOW TO ORDER

- Indicate the following information on order form:
- Quantity of each item.
 - Model number, including options. See "How To Build a Model Number".
 - Any special service required.

Note: • The indicates that a choice is required.
 • The absence of the indicates that no choice is required.
 • Alpha-numeric characters in place of indicate that no other alternatives are available.

HOW TO BUILD A MODEL NUMBER

- A** Select basic model.
- B** Select base option.

4CW	- 4 black casters
4GB	- 4 black glides
- C** Select top laminate surface.
 Refer to the **Product Color Options** page in this price list.
- D** Select edge color.
 Refer to the **Product Color Options** page in this price list.
- E** Select shell color.
 Refer to the **Product Color Options** page in this price list.

FINISH INFORMATION

Additional Laminate Offering
 KI offers laminates beyond those offered in the standard offering. Laminates that are currently available in the program can be viewed in KI product specification tools. Requests to add laminates to the program can be submitted via the product modification request process. Please note, requests to add laminates to the program must include the laminate manufacturer's name, color/pattern number, and finish code. Edge options are limited to standard edge colors. If a matching edge is required, this will need to be requested through the product modification request process and may be subject to additional costs. Due to varying manufacturing processes and quality issues with some laminates, some requests may be denied. Extended lead times and minimum order quantities may apply on orders containing special laminates. Contact the product modification team for questions or additional information regarding special laminates and pricing.

SPECIAL SERVICES

Special Carton Marking

With specially marked information N/C

Shipping

Ships assembled, FOB Pembroke, ON K8A 0E1, freight excluded. Freight class 100.

Specifications and prices are subject to change without prior notice.

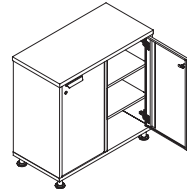
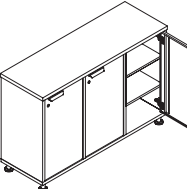

W x D x H	MODEL NUMBER										Approx. Packaged Weight	Freight Excluded Pricing Standard Lock	Laminate Grade 2 add to list price	
	Basic Model	Door Lock Option	Pull Option	Base	Top Color	Edge Color	Shell Color	Door Color	Lock Option	Lock Color				
36 x 18 x 36"	RKC361836DR	<input type="checkbox"/> <input type="checkbox"/> <input type="checkbox"/> <input type="checkbox"/> <input type="checkbox"/>	<input type="checkbox"/>	<input type="checkbox"/> <input type="checkbox"/>	<input type="checkbox"/> <input type="checkbox"/>	<input type="checkbox"/> <input type="checkbox"/>	<input type="checkbox"/> <input type="checkbox"/>	<input type="checkbox"/> <input type="checkbox"/>	<input type="checkbox"/> <input type="checkbox"/>	<input type="checkbox"/> <input type="checkbox"/>	<input type="checkbox"/> <input type="checkbox"/>	114.40#	\$ 1708	\$ 19
36 x 18 x 42"	RKC361842DR	<input type="checkbox"/> <input type="checkbox"/> <input type="checkbox"/> <input type="checkbox"/> <input type="checkbox"/>	<input type="checkbox"/>	<input type="checkbox"/> <input type="checkbox"/>	<input type="checkbox"/> <input type="checkbox"/>	<input type="checkbox"/> <input type="checkbox"/>	<input type="checkbox"/> <input type="checkbox"/>	<input type="checkbox"/> <input type="checkbox"/>	<input type="checkbox"/> <input type="checkbox"/>	<input type="checkbox"/> <input type="checkbox"/>	<input type="checkbox"/> <input type="checkbox"/>	128.10#	1745	19
 <p>RKC361836DR / RKC361842DR</p> <p>RCKC Single-Face Cubbies 2x3-With Doors</p> <ul style="list-style-type: none"> Laminate top (1-1/4" with 74P edge) Single sided storage (6 total compartments) Secure locking doors Unit ships assembled; glides/casters are field installed 														
54 x 18 x 36"	RKC541836DR	<input type="checkbox"/> <input type="checkbox"/> <input type="checkbox"/> <input type="checkbox"/> <input type="checkbox"/>	<input type="checkbox"/>	<input type="checkbox"/> <input type="checkbox"/>	<input type="checkbox"/> <input type="checkbox"/>	<input type="checkbox"/> <input type="checkbox"/>	<input type="checkbox"/> <input type="checkbox"/>	<input type="checkbox"/> <input type="checkbox"/>	<input type="checkbox"/> <input type="checkbox"/>	<input type="checkbox"/> <input type="checkbox"/>	<input type="checkbox"/> <input type="checkbox"/>	161.70#	\$ 2239	\$ 19
54 x 18 x 42"	RKC541842DR	<input type="checkbox"/> <input type="checkbox"/> <input type="checkbox"/> <input type="checkbox"/> <input type="checkbox"/>	<input type="checkbox"/>	<input type="checkbox"/> <input type="checkbox"/>	<input type="checkbox"/> <input type="checkbox"/>	<input type="checkbox"/> <input type="checkbox"/>	<input type="checkbox"/> <input type="checkbox"/>	<input type="checkbox"/> <input type="checkbox"/>	<input type="checkbox"/> <input type="checkbox"/>	<input type="checkbox"/> <input type="checkbox"/>	<input type="checkbox"/> <input type="checkbox"/>	180.70#	2295	19
 <p>RKC541836DR / RKC541842DR</p> <p>RCKC Single-Face Cubbies 3x3-With Doors</p> <ul style="list-style-type: none"> Laminate top (1-1/4" with 74P edge) Single sided storage (9 total compartments) Secure locking doors Unit ships assembled; glides/casters are field installed 														

A B C D E F G H I J

HOW TO ORDER

- Indicate the following information on order form:
- Quantity of each item.
 - Model number, including options. See "How To Build a Model Number".
 - Any special service required.

Note: • The indicates that a choice is required.
• The absence of the indicates that no choice is required.
• Alpha-numeric characters in place of indicate that no other alternatives are available.

HOW TO BUILD A MODEL NUMBER

- A** Select basic model.
- B** Select door lock option.

<input type="checkbox"/>	SLCKL	- Standard lock hinged left
<input type="checkbox"/>	SLCKR	- Standard lock hinged right
- C** Select pull option.

<input type="checkbox"/>	S6	- Beveled pull Black
<input type="checkbox"/>	S5	- Beveled pull Satin Chrome

 Pull selection only when SLCKR or SLCKL key lock is selected.
- D** Select base option.

<input type="checkbox"/>	4CW	- 4 black casters
<input type="checkbox"/>	4GB	- 4 black glides
- E** Select top laminate surface.
 Refer to the **Product Color Options** page in this price list.
- F** Select edge color.
 Refer to the **Product Color Options** page in this price list.
- G** Select shell color.
 Refer to the **Product Color Options** page in this price list.
- H** Select front door color.
 Refer to the **Product Color Options** page in this price list.
- I** Select lock option.

<input type="checkbox"/>	KS	- Key standard - 2 locks
<input type="checkbox"/>	KS	- Key standard - 3 locks
<input type="checkbox"/>	NLC	- No lock core - 2 locks
<input type="checkbox"/>	NLC	- No lock core - 3 locks
- J** Select lock color.
 Refer to the **Product Color Options** page in this price list.

FINISH INFORMATION

Additional Laminate Offering
 Additional laminates beyond KI standard offering, are available with two weeks extended leadtime. To specify additional laminates, use these designators followed by the supplier's color/pattern code:

Formica - LF/supplier's color pattern code
 Nevamar - LN/supplier's color pattern code
 Wilsonart - LW/supplier's color pattern code

KI's standard finish is the supplier's recommended finish for that color/pattern. Note: Nonstandard laminates from these suppliers (example: textured laminates), require an upcharge and additional leadtime. Contact KI.

SPECIAL SERVICES

Special Carton Marking
 With specially marked information N/C

Shipping
 Ships assembled, FOB Pembroke, ON K8A 0E1, freight excluded. Freight class 100.

Specifications and prices are subject to change without prior notice.



W x D x H	MODEL NUMBER										Approx. Packaged Weight	Freight Excluded Pricing Standard Lock	Laminate Grade 2 add to list price
	Basic Model	Door Lock Option	Pull Option	Base	Top Color	Edge Color	Shell Color	Door Color	Lock Option	Lock Color			
36 x 24 x 36"	RKC362436DR	<input type="checkbox"/> <input type="checkbox"/> <input type="checkbox"/> <input type="checkbox"/>	<input type="checkbox"/>	<input type="checkbox"/> <input type="checkbox"/>	<input type="checkbox"/> <input type="checkbox"/>	<input type="checkbox"/> <input type="checkbox"/>	<input type="checkbox"/>	<input type="checkbox"/> <input type="checkbox"/>	<input type="checkbox"/>	<input type="checkbox"/> <input type="checkbox"/>	208.20#	\$ 1949	\$ 19
36 x 24 x 42"	RKC362442DR	<input type="checkbox"/> <input type="checkbox"/> <input type="checkbox"/> <input type="checkbox"/>	<input type="checkbox"/>	<input type="checkbox"/> <input type="checkbox"/>	<input type="checkbox"/> <input type="checkbox"/>	<input type="checkbox"/> <input type="checkbox"/>	<input type="checkbox"/>	<input type="checkbox"/> <input type="checkbox"/>	<input type="checkbox"/>	<input type="checkbox"/> <input type="checkbox"/>	226.00#	2013	19
<p>RKC362436DR / RKC362442DR (hinged right shown)</p> <p>RCKC Double-Face Cubbies 2x3-With Doors</p> <ul style="list-style-type: none"> Laminate top (1-1/4" with 74P edge) Dual sided storage (12 total compartments) Secure locking doors Unit ships assembled; glides/casters are field installed 													
54 x 24 x 36"	RKC542436DR	<input type="checkbox"/> <input type="checkbox"/> <input type="checkbox"/> <input type="checkbox"/>	<input type="checkbox"/>	<input type="checkbox"/> <input type="checkbox"/>	<input type="checkbox"/> <input type="checkbox"/>	<input type="checkbox"/> <input type="checkbox"/>	<input type="checkbox"/>	<input type="checkbox"/> <input type="checkbox"/>	<input type="checkbox"/>	<input type="checkbox"/> <input type="checkbox"/>	275.40#	\$ 2592	\$ 27
54 x 24 x 42"	RKC542442DR	<input type="checkbox"/> <input type="checkbox"/> <input type="checkbox"/> <input type="checkbox"/>	<input type="checkbox"/>	<input type="checkbox"/> <input type="checkbox"/>	<input type="checkbox"/> <input type="checkbox"/>	<input type="checkbox"/> <input type="checkbox"/>	<input type="checkbox"/>	<input type="checkbox"/> <input type="checkbox"/>	<input type="checkbox"/>	<input type="checkbox"/> <input type="checkbox"/>	300.30#	2679	27
<p>RKC542436DR / RKC542442DR (hinged right shown)</p> <p>RCKC Double-Face Cubbies 3x3-With Doors</p> <ul style="list-style-type: none"> Laminate top (1-1/4" with 74P edge) Dual sided storage (18 total compartments) Secure locking doors Unit ships assembled; glides/casters are field installed 													

A B C D E F G H I J

HOW TO ORDER

- Indicate the following information on order form:
- Quantity of each item.
 - Model number, including options. See "How To Build a Model Number".
 - Any special service required.

Note: • The indicates that a choice is required.
• The absence of the indicates that no choice is required.
• Alpha-numeric characters in place of indicate that no other alternatives are available.

HOW TO BUILD A MODEL NUMBER

- A** Select basic model.
- B** Select door lock option.

SLCKL	- Standard lock hinged left
SLCKR	- Standard lock hinged right
- C** Select pull option.

S6	- Beveled pull Black
S5	- Beveled pull Satin Chrome

 Pull selection only when SLCKR or SLCKL key lock is selected.
- D** Select base option.

4CW	- 4 black casters
4GB	- 4 black glides
- E** Select top laminate surface.
Refer to the **Product Color Options** page in this price list.
- F** Select edge color.
Refer to the **Product Color Options** page in this price list.
- G** Select shell color.
Refer to the **Product Color Options** page in this price list.
- H** Select front door color.
Refer to the **Product Color Options** page in this price list.
- I** Select lock option.

KS	- Key standard - 4 locks
KS	- Key standard - 6 locks
NLC	- No lock core - 4 locks
NLC	- No lock core - 6 locks
- J** Select lock color.
Refer to the **Product Color Options** page in this price list.

FINISH INFORMATION

Additional Laminate Offering
Additional laminates beyond KI standard offering, are available with two weeks extended leadtime. To specify additional laminates, use these designators followed by the supplier's color/pattern code:

Formica - LF/supplier's color pattern code
 Nevamar - LN/supplier's color pattern code
 Wilsonart - LW/supplier's color pattern code

KI's standard laminate finish is the supplier's recommended finish for that color/pattern. Note: Nonstandard laminates from these suppliers (example: textured laminates) require a Product Modification Request. Contact customer service for details.



SPECIAL SERVICES

Special Carton Marking
With specially marked information N/C

Shipping
Ships assembled, FOB Pembroke, ON K8A 0E1, freight excluded. Freight class 100.

Specifications and prices are subject to change without prior notice.

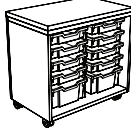
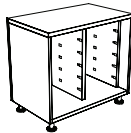

	MODEL	W x D x H	MODEL NUMBER			Approx. Packaged Weight	Freight Excluded Pricing
			Basic Model	Base	Shell Color		
 RCKT	Short 2-Column Unit, Open with (12)3" Totes • Single-Face only • Totes included are translucent with no lid (not included on the 'empty' model) • Unit ships assembled, including totes and rail sets; glides/casters are field installed	30 x 18 x 27-3/4"	RKT3018280P/3T	<input type="checkbox"/> <input type="checkbox"/> <input type="checkbox"/>	<input type="checkbox"/> <input type="checkbox"/>	87.8#	\$ 1224
 RCKT	Short 2-Column Unit, Open with (6)6" Totes • Single-Face only • Totes included are translucent with no lid (not included on the 'empty' model) • Unit ships assembled, including totes and rail sets; glides/casters are field installed	30 x 18 x 27-3/4"	RKT3018280P/6T	<input type="checkbox"/> <input type="checkbox"/> <input type="checkbox"/>	<input type="checkbox"/> <input type="checkbox"/>	83.9#	\$ 1129
 RCKT	Short 2-Column Unit, Open with (8)3" and (2)6" Totes • Single-Face only • Totes included are translucent with no lid (not included on the 'empty' model) • Unit ships assembled, including totes and rail sets; glides/casters are field installed	30 x 18 x 27-3/4"	RKT3018280P/36T	<input type="checkbox"/> <input type="checkbox"/> <input type="checkbox"/>	<input type="checkbox"/> <input type="checkbox"/>	86.5#	\$ 1203
 RCKT	Short 2-Column Unit, Open-Empty • Single-Face only • Tote and rail sets must be ordered separately and installed on-site • Unit ships assembled; glides/casters are field installed	30 x 18 x 27-3/4"	RKT3018280P/XT	<input type="checkbox"/> <input type="checkbox"/> <input type="checkbox"/>	<input type="checkbox"/> <input type="checkbox"/>	74.0#	\$ 954

A

B

C

HOW TO ORDER

- Indicate the following information on order form:
- Quantity of each item.
 - Model number, including options. See "How To Build a Model Number".
 - Any special service required.

Note:

- The indicates that a choice is required.
- The absence of the indicates that no choice is required.
- Alpha-numeric characters in place of indicate that no other alternatives are available.

HOW TO BUILD A MODEL NUMBER

- A** Select basic model.
- B** Select base option.
- | | |
|------------|-------------------|
| 4CW | - 4 black casters |
| 4GB | - 4 black glides |
- C** Select shell color.
Refer to the **Product Color Options** page in this price list.

SPECIAL SERVICES

Special Carton Marking



With specially marked information N/C

Shipping

Ships assembled, FOB Pembroke, ON K8A 0E1, freight excluded. Freight class 100.

Specifications and prices are subject to change without prior notice.

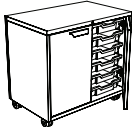

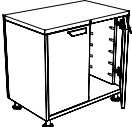
MODEL	W x D x H	MODEL NUMBER							Approx. Packaged Weight	Freight Excluded Pricing
		Basic Model	Pull Option	Base	Shell Color	Door Color	Lock Option	Lock Color		
 <p>Short 2-Column Unit with Doors and (12)3\" Totes • Single-Face only • Totes included are translucent with no lid (not included on the 'empty' model) • Unit ships assembled, including totes and rail sets; glides/casters are field installed • Secure locking doors</p>	30 x 18 x 27-3/4"	RKT301828DR/3T	<input type="checkbox"/>	<input type="checkbox"/>	<input type="checkbox"/>	<input type="checkbox"/>	<input type="checkbox"/>	<input type="checkbox"/>	112.1#	\$ 1459
 <p>Short 2-Column Unit with Doors and (6)6\" Totes • Single-Face only • Totes included are translucent with no lid (not included on the 'empty' model) • Unit ships assembled, including totes and rail sets; glides/casters are field installed • Secure locking doors</p>	30 x 18 x 27-3/4"	RKT301828DR/6T	<input type="checkbox"/>	<input type="checkbox"/>	<input type="checkbox"/>	<input type="checkbox"/>	<input type="checkbox"/>	<input type="checkbox"/>	108.3#	\$ 1366
 <p>Short 2-Column Unit with Doors and (8)3\" and (2)6\" Totes • Single-Face only • Totes included are translucent with no lid (not included on the 'empty' model) • Unit ships assembled, including totes and rail sets; glides/casters are field installed • Secure locking doors</p>	30 x 18 x 27-3/4"	RKT301828DR/36T	<input type="checkbox"/>	<input type="checkbox"/>	<input type="checkbox"/>	<input type="checkbox"/>	<input type="checkbox"/>	<input type="checkbox"/>	110.8#	\$ 1439
 <p>Short 2-Column Unit with Doors-Empty • Single-Face only • Tote and rail sets must be ordered separately and installed on-site • Unit ships assembled; glides/casters are field installed • Secure locking doors</p>	30 x 18 x 27-3/4"	RKT301828DR/XT	<input type="checkbox"/>	<input type="checkbox"/>	<input type="checkbox"/>	<input type="checkbox"/>	<input type="checkbox"/>	<input type="checkbox"/>	98.3#	\$ 1189

A **B** **C** **D** **E** **F** **G**

HOW TO ORDER

- Indicate the following information on order form:
- Quantity of each item.
 - Model number, including options. See "How To Build a Model Number".
 - Any special service required.

Note: • The indicates that a choice is required.
 • The absence of the indicates that no choice is required.
 • Alpha-numeric characters in place of indicate that no other alternatives are available.

HOW TO BUILD A MODEL NUMBER

Refer to the **Product Color Options** page in this price list.

- A** Select basic model.
- B** Select pull option.
 S6 - Beveled pull Black
 S5 - Beveled pull Satin Chrome
- C** Select base option.
 4CW - 4 black casters
 4GB - 4 black glides
- D** Select shell color.
 Refer to the **Product Color Options** page in this price list.
- E** Select front door color.
 Refer to the **Product Color Options** page in this price list.
- F** Select lock option.
 KS - Key standard - 2 locks
 NLC - No lock core - 2 locks
- G** Select lock color.

SPECIAL SERVICES

Special Carton Marking

With specially marked information N/C

Shipping

Ships assembled, FOB Pembroke, ON K8A 0E1, freight excluded. Freight class 100.

Specifications and prices are subject to change without prior notice.



MODEL	W x D x H	MODEL NUMBER			Approx. Packaged Weight	Freight Excluded Pricing
		Basic Model	Base	Shell Color		
<p>Short 3-Column Unit, Open with (18) 3\" Totes • Single-Face only • Totes included are translucent with no lid (not included on the 'empty' model) • Unit ships assembled, including totes and rail sets; glides/casters are field installed</p>	44 x 18 x 27-3/4\"	RKT441828OP/3T	<input type="checkbox"/> <input type="checkbox"/> <input type="checkbox"/>	<input type="checkbox"/> <input type="checkbox"/>	123.4#	\$ 1552
<p>Short 3-Column Unit, Open with (9) 6\" Totes • Single-Face only • Totes included are translucent with no lid (not included on the 'empty' model) • Unit ships assembled, including totes and rail sets; glides/casters are field installed</p>	44 x 18 x 27-3/4\"	RKT441828OP/6T	<input type="checkbox"/> <input type="checkbox"/> <input type="checkbox"/>	<input type="checkbox"/> <input type="checkbox"/>	117.5#	\$ 1420
<p>Short 3-Column Unit, Open with (12) 3\" and (3) 6\" Totes • Single-Face only • Totes included are translucent with no lid (not included on the 'empty' model) • Unit ships assembled, including totes and rail sets; glides/casters are field installed</p>	44 x 18 x 27-3/4\"	RKT441828OP/36T	<input type="checkbox"/> <input type="checkbox"/> <input type="checkbox"/>	<input type="checkbox"/> <input type="checkbox"/>	124.6#	\$ 1517
<p>Short 3-Column Unit, Open-Empty • Single-Face only • Tote and rail sets must be ordered separately and installed on-site • Unit ships assembled; glides/casters are field installed</p>	44 x 18 x 27-3/4\"	RKT441828OP/XT	<input type="checkbox"/> <input type="checkbox"/> <input type="checkbox"/>	<input type="checkbox"/> <input type="checkbox"/>	102.7#	\$ 1164

A **B** **C**

HOW TO ORDER

- Indicate the following information on order form:
- Quantity of each item.
 - Model number, including options. See "How To Build a Model Number".
 - Any special service required.

Note:

- The indicates that a choice is required.
- The absence of the indicates that no choice is required.
- Alpha-numeric characters in place of indicate that no other alternatives are available.

HOW TO BUILD A MODEL NUMBER

- A** Select basic model.
- B** Select base option.
- | | |
|------------|-------------------|
| 4CW | - 4 black casters |
| 4GB | - 4 black glides |
- C** Select shell color.
 Refer to the **Product Color Options** page in this price list.

SPECIAL SERVICES

Special Carton Marking

With specially marked information N/C

Shipping

Ships assembled, FOB Pembroke, ON K8A 0E1, freight excluded. Freight class 100.

Specifications and prices are subject to change without prior notice.

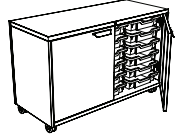
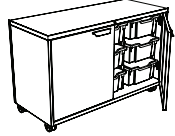
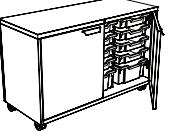
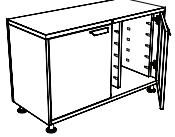

MODEL	W x D x H	MODEL NUMBER							Approx. Packaged Weight	Freight Excluded Pricing
		Basic Model	Pull Option	Base	Shell Color	Door Color	Lock Option	Lock Color		
 <p>RCKT</p> <p>Short 3-Column Unit with Doors and (18)3\" Totes</p> <ul style="list-style-type: none"> • Single-Face only • Totes included are translucent with no lid (not included on the 'empty' model) • Unit ships assembled, including totes and rail sets; glides/casters are field installed • Secure locking doors 	44 x 18 x 27-3/4"	RKT441828DR/3T	<input type="checkbox"/>	<input type="checkbox"/>	<input type="checkbox"/>	<input type="checkbox"/>	<input type="checkbox"/>	<input type="checkbox"/>	149.4#	\$ 1799
 <p>RCKT</p> <p>Short 3-Column Unit with Doors and (9)6\" Totes</p> <ul style="list-style-type: none"> • Single-Face only • Totes included are translucent with no lid (not included on the 'empty' model) • Unit ships assembled, including totes and rail sets; glides/casters are field installed • Secure locking doors 	44 x 18 x 27-3/4"	RKT441828DR/6T	<input type="checkbox"/>	<input type="checkbox"/>	<input type="checkbox"/>	<input type="checkbox"/>	<input type="checkbox"/>	<input type="checkbox"/>	143.5#	\$ 1668
 <p>RCKT</p> <p>Short 3-Column Unit with Doors and (12)3\" and (3)6\" Totes</p> <ul style="list-style-type: none"> • Single-Face only • Totes included are translucent with no lid (not included on the 'empty' model) • Unit ships assembled, including totes and rail sets; glides/casters are field installed • Secure locking doors 	44 x 18 x 27-3/4"	RKT441828DR/36T	<input type="checkbox"/>	<input type="checkbox"/>	<input type="checkbox"/>	<input type="checkbox"/>	<input type="checkbox"/>	<input type="checkbox"/>	150.6#	\$ 1766
 <p>RCKT</p> <p>Short 3-Column Unit with Doors-Empty</p> <ul style="list-style-type: none"> • Single-Face only • Tote and rail sets must be ordered separately and installed on-site • Unit ships assembled; glides/casters are field installed • Secure locking doors 	44 x 18 x 27-3/4"	RKT441828DR/XT	<input type="checkbox"/>	<input type="checkbox"/>	<input type="checkbox"/>	<input type="checkbox"/>	<input type="checkbox"/>	<input type="checkbox"/>	128.7#	\$ 1411

A **B** **C** **D** **E** **F** **G**

HOW TO ORDER

- Indicate the following information on order form:
1. Quantity of each item.
 2. Model number, including options. See "How To Build a Model Number".
 3. Any special service required.

Note:

- The indicates that a choice is required.
- The absence of the indicates that no choice is required.
- Alpha-numeric characters in place of indicate that no other alternatives are available.

HOW TO BUILD A MODEL NUMBER

Refer to the **Product Color Options** page in this price list.

- A** Select basic model.
- B** Select pull option.
 - S6** - Beveled pull Black
 - S5** - Beveled pull Satin Chrome
- C** Select base option.
 - 4CW** - 4 black casters
 - 4GB** - 4 black glides
- D** Select shell color. Refer to the **Product Color Options** page in this price list.
- E** Select front door color. Refer to the **Product Color Options** page in this price list.
- F** Select lock option.
 - KS** - Key standard - 2 locks
 - NLC** - No lock core - 2 locks
- G** Select lock color.

SPECIAL SERVICES

Special Carton Marking

With specially marked information N/C

Shipping

Ships assembled, FOB Pembroke, ON K8A 0E1, freight excluded. Freight class 100.

Specifications and prices are subject to change without prior notice.

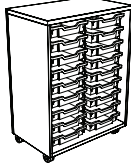
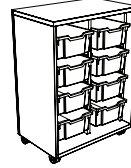
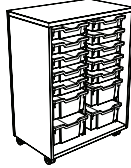
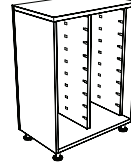

MODEL	W x D x H	MODEL NUMBER			Approx. Packaged Weight	Freight Excluded Pricing
		Basic Model	Base	Shell Color		
 <p>Tall 2-Column Unit, Open with (18)3” Totes</p> <ul style="list-style-type: none"> • Single-Face only • Totes included are translucent with no lid (not included on the 'empty' model) • Unit ships assembled, including totes and rail sets; glides/casters are field installed 	30 x 18 x 40-3/4”	RKT3018410P/3T	<input type="checkbox"/> <input type="checkbox"/> <input type="checkbox"/>	<input type="checkbox"/> <input type="checkbox"/>	111.8#	\$ 1494
RCKT						
 <p>Tall 2-Column Unit, Open with (8)6” Totes</p> <ul style="list-style-type: none"> • Single-Face only • Totes included are translucent with no lid (not included on the 'empty' model) • Unit ships assembled, including totes and rail sets; glides/casters are field installed 	30 x 18 x 40-3/4”	RKT3018410P/6T	<input type="checkbox"/> <input type="checkbox"/> <input type="checkbox"/>	<input type="checkbox"/> <input type="checkbox"/>	104.3#	\$ 1338
RCKT						
 <p>Tall 2-Column Unit, Open with (10)3” and (4)6” Totes</p> <ul style="list-style-type: none"> • Single-Face only • Totes included are translucent with no lid (not included on the 'empty' model) • Unit ships assembled, including totes and rail sets; glides/casters are field installed 	30 x 18 x 40-3/4”	RKT3018410P/36T	<input type="checkbox"/> <input type="checkbox"/> <input type="checkbox"/>	<input type="checkbox"/> <input type="checkbox"/>	109.2#	\$ 1443
RCKT						
 <p>Tall 2-Column Unit, Open-Empty</p> <ul style="list-style-type: none"> • Single-Face only • Tote and rail sets must be ordered separately and installed on-site • Unit ships assembled; glides/casters are field installed 	30 x 18 x 40-3/4”	RKT3018410P/XT	<input type="checkbox"/> <input type="checkbox"/> <input type="checkbox"/>	<input type="checkbox"/> <input type="checkbox"/>	91.1#	\$ 1107
RCKT						

A **B** **C**

HOW TO ORDER

- Indicate the following information on order form:
1. Quantity of each item.
 2. Model number, including options. See “How To Build a Model Number”.
 3. Any special service required.

Note:

- The indicates that a choice is required.
- The absence of the indicates that no choice is required.
- Alpha-numeric characters in place of indicate that no other alternatives are available.

HOW TO BUILD A MODEL NUMBER

- A** Select basic model.
- B** Select base option.

4CW	- 4 black casters
4GB	- 4 black glides
- C** Select shell color. Refer to the **Product Color Options** page in this price list.

SPECIAL SERVICES

Special Carton Marking



With specially marked information N/C

Shipping

Ships assembled, FOB Pembroke, ON K8A 0E1, freight excluded. Freight class 100.

Specifications and prices are subject to change without prior notice.

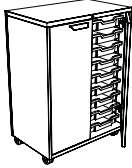

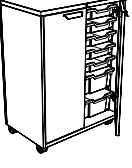
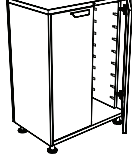
MODEL	W x D x H	MODEL NUMBER							Approx. Packaged Weight	Freight Excluded Pricing
		Basic Model	Pull Option	Base	Shell Color	Door Color	Lock Option	Lock Color		
 <p>Tall 2-Column Unit with Doors and (18)3" Totes • Single-Face only • Totes included are translucent with no lid (not included on the 'empty' model) • Unit ships assembled, including totes and rail sets; glides/casters are field installed • Secure locking doors</p>	30 x 18 x 40-3/4"	RKT301841DR/3T	<input type="checkbox"/>	<input type="checkbox"/>	<input type="checkbox"/>	<input type="checkbox"/>	<input type="checkbox"/>	<input type="checkbox"/>	137.8#	\$ 1746
 <p>Tall 2-Column Unit with Doors and (8)6" Totes • Single-Face only • Totes included are translucent with no lid (not included on the 'empty' model) • Unit ships assembled, including totes and rail sets; glides/casters are field installed • Secure locking doors</p>	30 x 18 x 40-3/4"	RKT301841DR/6T	<input type="checkbox"/>	<input type="checkbox"/>	<input type="checkbox"/>	<input type="checkbox"/>	<input type="checkbox"/>	<input type="checkbox"/>	130.3#	\$ 1588
 <p>Tall 2-Column Unit with Doors and (10)3" and (4)6" Totes • Single-Face only • Totes included are translucent with no lid (not included on the 'empty' model) • Unit ships assembled, including totes and rail sets; glides/casters are field installed • Secure locking doors</p>	30 x 18 x 40-3/4"	RKT301841DR/36T	<input type="checkbox"/>	<input type="checkbox"/>	<input type="checkbox"/>	<input type="checkbox"/>	<input type="checkbox"/>	<input type="checkbox"/>	135.2#	\$ 1694
 <p>Tall 2-Column Unit with Doors-Empty • Single-Face only • Tote and rail sets must be ordered separately and installed on-site • Unit ships assembled; glides/casters are field installed • Secure locking doors</p>	30 x 18 x 40-3/4"	RKT301841DR/XT	<input type="checkbox"/>	<input type="checkbox"/>	<input type="checkbox"/>	<input type="checkbox"/>	<input type="checkbox"/>	<input type="checkbox"/>	117.1#	\$ 1357

A **B** **C** **D** **E** **F** **G**

HOW TO ORDER

- Indicate the following information on order form:
- Quantity of each item.
 - Model number, including options. See "How To Build a Model Number".
 - Any special service required.

Note: • The indicates that a choice is required.
 • The absence of the indicates that no choice is required.
 • Alpha-numeric characters in place of indicate that no other alternatives are available.

HOW TO BUILD A MODEL NUMBER

Refer to the **Product Color Options** page in this price list.

- A** Select basic model.
- B** Select pull option.
 S6 - Beveled pull Black
 S5 - Beveled pull Satin Chrome
- C** Select base option.
 4CW - 4 black casters
 4GB - 4 black glides
- D** Select shell color.
 Refer to the **Product Color Options** page in this price list.
- E** Select front door color.
 Refer to the **Product Color Options** page in this price list.
- F** Select lock option.
 KS - Key standard - 2 locks
 NLC - No lock core - 2 locks
- G** Select lock color.

SPECIAL SERVICES

Special Carton Marking

With specially marked information N/C

Shipping

Ships assembled, FOB Pembroke, ON K8A 0E1, freight excluded. Freight class 100.

Specifications and prices are subject to change without prior notice.

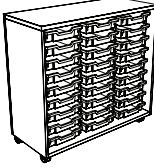
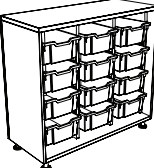
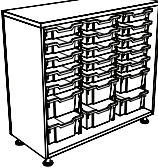
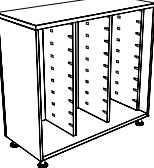

MODEL	W x D x H	MODEL NUMBER			Approx. Packaged Weight	Freight Excluded Pricing
		Basic Model	Base	Shell Color		
 <p>Tall 3-Column Unit, Open with (27)3” Totes • Single-Face only • Totes included are translucent with no lid (not included on the 'empty' model) • Unit ships assembled, including totes and rail sets; glides/casters are field installed</p>	44 x 18 x 40-3/4”	RKT441841OP/3T	<input type="checkbox"/> <input type="checkbox"/> <input type="checkbox"/>	<input type="checkbox"/>	156.7#	\$ 1903
RCKT						
 <p>Tall 3-Column Unit, Open with (12)6” Totes • Single-Face only • Totes included are translucent with no lid (not included on the 'empty' model) • Unit ships assembled, including totes and rail sets; glides/casters are field installed</p>	44 x 18 x 40-3/4”	RKT441841OP/6T	<input type="checkbox"/> <input type="checkbox"/> <input type="checkbox"/>	<input type="checkbox"/>	145.4#	\$ 1699
RCKT						
 <p>Tall 3-Column Unit, Open with (15)3” and (6)6” Totes • Single-Face only • Totes included are translucent with no lid (not included on the 'empty' model) • Unit ships assembled, including totes and rail sets; glides/casters are field installed</p>	44 x 18 x 40-3/4”	RKT441841OP/36T	<input type="checkbox"/> <input type="checkbox"/> <input type="checkbox"/>	<input type="checkbox"/>	147.0#	\$ 1857
RCKT						
 <p>Tall 3-Column Unit, Open-Empty • Single-Face only • Tote and rail sets must be ordered separately and installed on-site • Unit ships assembled; glides/casters are field installed</p>	44 x 18 x 40-3/4”	RKT441841OP/XT	<input type="checkbox"/> <input type="checkbox"/> <input type="checkbox"/>	<input type="checkbox"/>	125.6#	\$ 1339
RCKT						

A **B** **C**

HOW TO ORDER

- Indicate the following information on order form:
- Quantity of each item.
 - Model number, including options. See “How To Build a Model Number”.
 - Any special service required.

Note:

- The indicates that a choice is required.
- The absence of the indicates that no choice is required.
- Alpha-numeric characters in place of indicate that no other alternatives are available.

HOW TO BUILD A MODEL NUMBER

- A** Select basic model.
- B** Select base option.

4CW	- 4 black casters
4GB	- 4 black glides
- C** Select shell color. Refer to the **Product Color Options** page in this price list.

SPECIAL SERVICES

Special Carton Marking

With specially marked information N/C

Shipping

Ships assembled, FOB Pembroke, ON K8A 0E1, freight excluded. Freight class 100.

Specifications and prices are subject to change without prior notice.

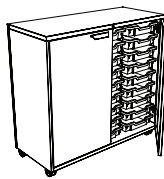
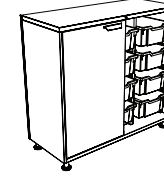
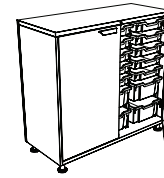
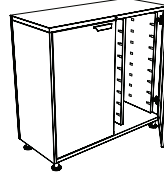

MODEL	W x D x H	MODEL NUMBER							Approx. Packaged Weight	Freight Excluded Pricing
		Basic Model	Pull Option	Base	Shell Color	Door Color	Lock Option	Lock Color		
 <p>Tall 3-Column Unit with Doors and (27)3” Totes • Single-Face only • Totes included are translucent with no lid (not included on the ‘empty’ model) • Unit ships assembled, including totes and rail sets; glides/casters are field installed • Secure locking doors</p>	44 x 18 x 40-3/4”	RKT441841DR/3T	<input type="checkbox"/>	<input type="checkbox"/>	<input type="checkbox"/>	<input type="checkbox"/>	<input type="checkbox"/>	<input type="checkbox"/>	182.7#	\$ 2133
 <p>Tall 3-Column Unit with Doors and (12)6” Totes • Single-Face only • Totes included are translucent with no lid (not included on the ‘empty’ model) • Unit ships assembled, including totes and rail sets; glides/casters are field installed • Secure locking doors</p>	44 x 18 x 40-3/4”	RKT441841DR/6T	<input type="checkbox"/>	<input type="checkbox"/>	<input type="checkbox"/>	<input type="checkbox"/>	<input type="checkbox"/>	<input type="checkbox"/>	171.4#	\$ 1930
 <p>Tall 3-Column Unit with Doors and (15)3” and (6)6” Totes • Single-Face only • Totes included are translucent with no lid (not included on the ‘empty’ model) • Unit ships assembled, including totes and rail sets; glides/casters are field installed • Secure locking doors</p>	44 x 18 x 40-3/4”	RKT441841DR/36T	<input type="checkbox"/>	<input type="checkbox"/>	<input type="checkbox"/>	<input type="checkbox"/>	<input type="checkbox"/>	<input type="checkbox"/>	173.0#	\$ 2086
 <p>Tall 3-Column Unit with Doors-Empty • Single-Face only • Tote and rail sets must be ordered separately and installed on-site • Unit ships assembled; glides/casters are field installed • Secure locking doors</p>	44 x 18 x 40-3/4”	RKT441841DR/XT	<input type="checkbox"/>	<input type="checkbox"/>	<input type="checkbox"/>	<input type="checkbox"/>	<input type="checkbox"/>	<input type="checkbox"/>	151.6#	\$ 1568

A **B** **C** **D** **E** **F** **G**

HOW TO ORDER

- Indicate the following information on order form:
- Quantity of each item.
 - Model number, including options. See “How To Build a Model Number”.
 - Any special service required.

Note: • The indicates that a choice is required.
 • The absence of the indicates that no choice is required.
 • Alpha-numeric characters in place of indicate that no other alternatives are available.

HOW TO BUILD A MODEL NUMBER

Refer to the **Product Color Options** page in this price list.

- A**Select basic model.
- B**Select pull option.
S6 - Beveled pull Black
S5 - Beveled pull Satin Chrome
- C**Select base option.
4CW - 4 black casters
4GB - 4 black glides
- D**Select shell color.
 Refer to the **Product Color Options** page in this price list.
- E**Select front door color.
 Refer to the **Product Color Options** page in this price list.
- F**Select lock option.
KS - Key standard - 2 locks
NLC - No lock core - 2 locks
- G**Select lock color.

SPECIAL SERVICES

Special Carton Marking

With specially marked information N/C

Shipping

Ships assembled, FOB Pembroke, ON K8A 0E1, freight excluded. Freight class 100.

Specifications and prices are subject to change without prior notice.



Ruckus® Storage (Freight Excluded Pricing)

Totes with Laminate Top

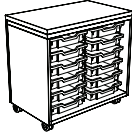

Ruckus® Storage (Freight Excluded Pricing)

Totes with Laminate Top

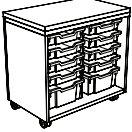
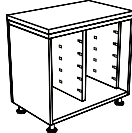
MODEL	W x D x H	MODEL NUMBER					Approx. Packaged Weight	Freight Excluded Pricing	Laminate Grade 2 add to list price
		Basic Model	Base	Top Color	Edge Color	Shell Color			
 <p>RCKT</p> <p>Short 2-Column Unit, Open with Laminate top and (12)3" Totes</p> <ul style="list-style-type: none"> Laminate top (1-1/4" with 74P edge) Single-Face only Totes included are translucent with no lid (not included on the 'empty' model) Unit ships assembled, including totes and rail sets; glides/casters are field installed 	30 x 18 x 29"	RKT301829OPT/3T	<input type="checkbox"/>	<input type="checkbox"/>	<input type="checkbox"/>	<input type="checkbox"/>	107.2#	\$ 1471	\$ 19
 <p>RCKT</p> <p>Short 2-Column Unit, Open with Laminate top and (6)6" Totes</p> <ul style="list-style-type: none"> Laminate top (1-1/4" with 74P edge) Single-Face only Totes included are translucent with no lid (not included on the 'empty' model) Unit ships assembled, including totes and rail sets; glides/casters are field installed 	30 x 18 x 29"	RKT301829OPT/6T	<input type="checkbox"/>	<input type="checkbox"/>	<input type="checkbox"/>	<input type="checkbox"/>	103.4#	\$ 1375	\$ 19
 <p>RCKT</p> <p>Short 2-Column Unit, Open with Laminate top and (8)3" and (2)6" Totes</p> <ul style="list-style-type: none"> Laminate top (1-1/4" with 74P edge) Single-Face only Totes included are translucent with no lid (not included on the 'empty' model) Unit ships assembled, including totes and rail sets; glides/casters are field installed 	30 x 18 x 29"	RKT301829OPT/36T	<input type="checkbox"/>	<input type="checkbox"/>	<input type="checkbox"/>	<input type="checkbox"/>	105.9#	\$ 1450	\$ 19
 <p>RCKT</p> <p>Short 2-Column Unit, Open with Laminate top-Empty</p> <ul style="list-style-type: none"> Laminate top (1-1/4" with 74P edge) Single-Face only Tote and rail sets must be ordered separately and installed on-site Unit ships assembled; glides/casters are field installed 	30 x 18 x 29"	RKT301829OPT/XT	<input type="checkbox"/>	<input type="checkbox"/>	<input type="checkbox"/>	<input type="checkbox"/>	93.4#	\$ 1201	\$ 19
			A	B	C	D	E		

HOW TO ORDER

- Indicate the following information on order form:
- Quantity of each item.
 - Model number, including options. See "How To Build a Model Number".
 - Any special service required.

Note:

- The indicates that a choice is required.
- The absence of the indicates that no choice is required.
- Alpha-numeric characters in place of indicate that no other alternatives are available.

HOW TO BUILD A MODEL NUMBER

- A** Select basic model.
- B** Select base option.

4CW	- 4 black casters
4GB	- 4 black glides
- C** Select top laminate surface. Refer to the **Product Color Options** page in this price list.
- D** Select edge color. Refer to the **Product Color Options** page in this price list.
- E** Select shell color. Refer to the **Product Color Options** page in this price list.

FINISH INFORMATION

Additional Laminate Offering

KI offers laminates beyond those offered in the standard offering. Laminates that are currently available in the program can be viewed in KI product specification tools. Requests to add laminates to the program can be submitted via the product modification request process. Please note, requests to add laminates to the program must include the laminate manufacturer's name, color/pattern number, and finish code. Edge options are limited to standard edge colors. If a matching edge is required, this will need to be requested through the product modification request process and may be subject to additional costs. Due to varying manufacturing processes and quality issues with some laminates, some requests may be denied. Extended lead times and minimum order quantities may apply on orders containing special laminates. Contact the product modification team for questions or additional information regarding special laminates and pricing.

SPECIAL SERVICES

Special Carton Marking

With specially marked information N/C

Shipping

Ships assembled, FOB Pembroke, ON K8A 0E1, freight excluded. Freight class 100.

Specifications and prices are subject to change without prior notice.



Ruckus® Storage (Freight Excluded Pricing)

Totes with Laminate Top

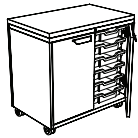
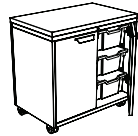

Ruckus® Storage (Freight Excluded Pricing)

Totes with Laminate Top

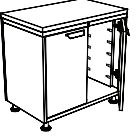
MODEL	W x D x H	MODEL NUMBER									Approx. Packaged Weight	Freight Excluded Pricing	Laminate Grade 2 add to list price
		Basic Model	Pull Option	Base	Top Color	Edge Color	Shell Color	Door Color	Lock Option	Lock Color			
 <p>Short 2-Column Unit with Doors, Laminate Top and (12)3" Totes</p> <ul style="list-style-type: none"> Laminate top (1-1/4" with 74P edge) Single-Face only Totes included are translucent with no lid (not included on the 'empty' model) Unit ships assembled, including totes and rail sets; glides/casters are field installed Secure locking doors 	30 x 18 x 29"	RKT301829DRT/3T	<input type="checkbox"/>	<input type="checkbox"/>	<input type="checkbox"/>	<input type="checkbox"/>	<input type="checkbox"/>	<input type="checkbox"/>	<input type="checkbox"/>	<input type="checkbox"/>	131.5#	\$ 1706	\$ 19
 <p>Short 2-Column Unit with Doors, Laminate Top and (6)6" Totes</p> <ul style="list-style-type: none"> Laminate top (1-1/4" with 74P edge) Single-Face only Totes included are translucent with no lid (not included on the 'empty' model) Unit ships assembled, including totes and rail sets; glides/casters are field installed Secure locking doors 	30 x 18 x 29"	RKT301829DRT/6T	<input type="checkbox"/>	<input type="checkbox"/>	<input type="checkbox"/>	<input type="checkbox"/>	<input type="checkbox"/>	<input type="checkbox"/>	<input type="checkbox"/>	<input type="checkbox"/>	127.7#	\$ 1612	\$ 19
 <p>Short 2-Column Unit with Doors, Laminate Top and (8)3" and (2)6" Totes</p> <ul style="list-style-type: none"> Laminate top (1-1/4" with 74P edge) Single-Face only Totes included are translucent with no lid (not included on the 'empty' model) Unit ships assembled, including totes and rail sets; glides/casters are field installed Secure locking doors 	30 x 18 x 29"	RKT301829DRT/36T	<input type="checkbox"/>	<input type="checkbox"/>	<input type="checkbox"/>	<input type="checkbox"/>	<input type="checkbox"/>	<input type="checkbox"/>	<input type="checkbox"/>	<input type="checkbox"/>	130.2#	\$ 1686	\$ 19
 <p>Short 2-Column Unit with Doors and Laminate Top-Empty</p> <ul style="list-style-type: none"> Laminate top (1-1/4" with 74P edge) Single-Face only Tote and rail sets must be ordered separately and installed on-site Unit ships assembled; glides/casters are field installed Secure locking doors 	30 x 18 x 29"	RKT301829DRT/XT	<input type="checkbox"/>	<input type="checkbox"/>	<input type="checkbox"/>	<input type="checkbox"/>	<input type="checkbox"/>	<input type="checkbox"/>	<input type="checkbox"/>	<input type="checkbox"/>	117.7#	\$ 1436	\$ 19

A B C D E F G H I

HOW TO ORDER

- Indicate the following information on order form:
- Quantity of each item.
 - Model number, including options. See "How To Build a Model Number".
 - Any special service required.

Note: • The indicates that a choice is required.
 • The absence of the indicates that no choice is required.
 • Alpha-numeric characters in place of indicate that no other alternatives are available.

HOW TO BUILD A MODEL NUMBER

- A** Select basic model.
- B** Select pull option.
 - S6** - Beveled pull Black
 - S5** - Beveled pull Satin Chrome
- C** Select base option.
 - 4CW** - 4 black casters
 - 4GB** - 4 black glides
- D** Select top laminate surface. Refer to the **Product Color Options** page in this price list.
- E** Select edge color. Refer to the **Product Color Options** page in this price list.
- F** Select shell color. Refer to the **Product Color Options** page in this price list.
- G** Select front door color.

Refer to the **Product Color Options** page in this price list.

- H** Select lock option.
 - KS** - Key standard - 2 locks
 - NLC** - No lock core - 2 locks

I Select lock color. Refer to the **Product Color Options** page in this price list.

FINISH INFORMATION

Additional Laminate Offering

KI offers laminates beyond those offered in the standard offering. Laminates that are currently available in the program can be viewed in KI product specification tools. Requests to add laminates to the program can be submitted via the product modification request process. Please note, requests to add laminates to the program must include the laminate manufacturer's name, color/pattern number, and finish code. Edge options are limited to standard edge colors. If a matching edge is required, this will need to be requested through the product modification request process and may be subject to additional costs. Due to varying manufacturing processes and quality issues with some laminates, some requests may be denied. Extended lead times and minimum order quantities may apply on orders containing special laminates. Contact the product modification team for questions or additional information regarding special laminates and pricing.

SPECIAL SERVICES

Special Carton Marking

With specially marked information N/C

Shipping

Ships assembled, FOB Pembroke, ON K8A 0E1, freight excluded. Freight class 100.

Specifications and prices are subject to change without prior notice.

Ruckus® Storage (Freight Excluded Pricing)

Totes with Laminate Top



Ruckus® Storage (Freight Excluded Pricing)

Totes with Laminate Top

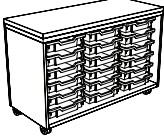
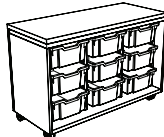
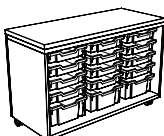
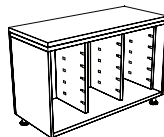
MODEL	W x D x H	MODEL NUMBER					Approx. Packaged Weight	Freight Excluded Pricing	Laminate Grade 2 add to list price
		Basic Model	Base	Top Color	Edge Color	Shell Color			
 <p>RCKT</p> <p>Short 3-Column Unit, Open with Laminate top and (18)3" Totes</p> <ul style="list-style-type: none"> Laminate top (1-1/4" with 74P edge) Single-Face only Totes included are translucent with no lid (not included on the 'empty' model) Unit ships assembled, including totes and rail sets; glides/casters are field installed 	44 x 18 x 29"	RKT441829OPT/3T	<input type="checkbox"/>	<input type="checkbox"/>	<input type="checkbox"/>	<input type="checkbox"/>	151.1#	\$ 1840	\$ 19
 <p>RCKT</p> <p>Short 3-Column Unit, Open with Laminate top and (9)6" Totes</p> <ul style="list-style-type: none"> Laminate top (1-1/4" with 74P edge) Single-Face only Totes included are translucent with no lid (not included on the 'empty' model) Unit ships assembled, including totes and rail sets; glides/casters are field installed 	44 x 18 x 29"	RKT441829OPT/6T	<input type="checkbox"/>	<input type="checkbox"/>	<input type="checkbox"/>	<input type="checkbox"/>	145.9#	\$ 1708	\$ 19
 <p>RCKT</p> <p>Short 3-Column Unit, Open with Laminate top and (12)3" and (3)6" Totes</p> <ul style="list-style-type: none"> Laminate top (1-1/4" with 74P edge) Single-Face only Totes included are translucent with no lid (not included on the 'empty' model) Unit ships assembled, including totes and rail sets; glides/casters are field installed 	44 x 18 x 29"	RKT441829OPT/36T	<input type="checkbox"/>	<input type="checkbox"/>	<input type="checkbox"/>	<input type="checkbox"/>	153.0#	\$ 1809	\$ 19
 <p>RCKT</p> <p>Short 3-Column Unit, Open with Laminate top-Empty</p> <ul style="list-style-type: none"> Laminate top (1-1/4" with 74P edge) Single-Face only Tote and rail sets must be ordered separately and installed on-site Unit ships assembled; glides/casters are field installed 	44 x 18 x 29"	RKT441829OPT/XT	<input type="checkbox"/>	<input type="checkbox"/>	<input type="checkbox"/>	<input type="checkbox"/>	131.1#	\$ 1452	\$ 19
			A	B	C	D	E		

HOW TO ORDER

- Indicate the following information on order form:
- Quantity of each item.
 - Model number, including options. See "How To Build a Model Number".
 - Any special service required.

Note:

- The indicates that a choice is required.
- The absence of the indicates that no choice is required.
- Alpha-numeric characters in place of indicate that no other alternatives are available.

HOW TO BUILD A MODEL NUMBER

- A** Select basic model.
- B** Select base option.

4CW	- 4 black casters
4GB	- 4 black glides
- C** Select top laminate surface. Refer to the **Product Color Options** page in this price list.
- D** Select edge color. Refer to the **Product Color Options** page in this price list.
- E** Select shell color. Refer to the **Product Color Options** page in this price list.

FINISH INFORMATION

Additional Laminate Offering

KI offers laminates beyond those offered in the standard offering. Laminates that are currently available in the program can be viewed in KI product specification tools. Requests to add laminates to the program can be submitted via the product modification request process. Please note, requests to add laminates to the program must include the laminate manufacturer's name, color/pattern number, and finish code. Edge options are limited to standard edge colors. If a matching edge is required, this will need to be requested through the product modification request process and may be subject to additional costs. Due to varying manufacturing processes and quality issues with some laminates, some requests may be denied. Extended lead times and minimum order quantities may apply on orders containing special laminates. Contact the product modification team for questions or additional information regarding special laminates and pricing.

SPECIAL SERVICES

Special Carton Marking

With specially marked information N/C

Shipping

Ships assembled, FOB Pembroke, ON K8A 0E1, freight excluded. Freight class 100.

Specifications and prices are subject to change without prior notice.

Ruckus® Storage (Freight Excluded Pricing)

Totes with Laminate Top



Ruckus® Storage (Freight Excluded Pricing)

Totes with Laminate Top

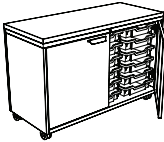
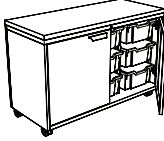
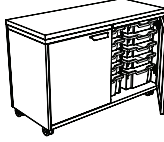
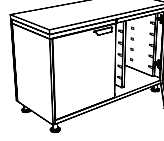
MODEL	W x D x H	MODEL NUMBER									Approx. Packaged Weight	Freight Excluded Pricing	Laminate Grade 2 add to list price
		Basic Model	Pull Option	Base	Top Color	Edge Color	Shell Color	Door Color	Lock Option	Lock Color			
 RCKT Short 3-Column Unit with Doors, Laminate Top and (18)3" Totes • Laminate top (1-1/4" with 74P edge) • Single-Face only • Totes included are translucent with no lid (not included on the 'empty' model) • Unit ships assembled, including totes and rail sets; glides/casters are field installed • Secure locking doors	44 x 18 x 29"	RKT441829DRT/3T	<input type="checkbox"/>	<input type="checkbox"/>	<input type="checkbox"/>	<input type="checkbox"/>	<input type="checkbox"/>	<input type="checkbox"/>	<input type="checkbox"/>	<input type="checkbox"/>	177.8#	\$ 2091	\$ 19
 RCKT Short 3-Column Unit with Doors, Laminate Top and (9)6" Totes • Laminate top (1-1/4" with 74P edge) • Single-Face only • Totes included are translucent with no lid (not included on the 'empty' model) • Unit ships assembled, including totes and rail sets; glides/casters are field installed • Secure locking doors	44 x 18 x 29"	RKT441829DRT/6T	<input type="checkbox"/>	<input type="checkbox"/>	<input type="checkbox"/>	<input type="checkbox"/>	<input type="checkbox"/>	<input type="checkbox"/>	<input type="checkbox"/>	<input type="checkbox"/>	171.9#	\$ 1959	\$ 19
 RCKT Short 3-Column Unit with Doors, Laminate Top and (12)3" and (3)6" Totes • Laminate top (1-1/4" with 74P edge) • Single-Face only • Totes included are translucent with no lid (not included on the 'empty' model) • Unit ships assembled, including totes and rail sets; glides/casters are field installed • Secure locking doors	44 x 18 x 29"	RKT441829DRT/36T	<input type="checkbox"/>	<input type="checkbox"/>	<input type="checkbox"/>	<input type="checkbox"/>	<input type="checkbox"/>	<input type="checkbox"/>	<input type="checkbox"/>	<input type="checkbox"/>	179.0#	\$ 2057	\$ 19
 RCKT Short 3-Column Unit with Doors and Laminate Top-Empty • Laminate top (1-1/4" with 74P edge) • Single-Face only • Tote and rail sets must be ordered separately and installed on-site • Unit ships assembled; glides/casters are field installed • Secure locking doors	44 x 18 x 29"	RKT441829DRT/XT	<input type="checkbox"/>	<input type="checkbox"/>	<input type="checkbox"/>	<input type="checkbox"/>	<input type="checkbox"/>	<input type="checkbox"/>	<input type="checkbox"/>	<input type="checkbox"/>	157.1#	\$ 1703	\$ 19

A **B** **C** **D** **E** **F** **G** **H** **I**

HOW TO ORDER

- Indicate the following information on order form:
- Quantity of each item.
 - Model number, including options. See "How To Build a Model Number".
 - Any special service required.

Note: • The indicates that a choice is required.
 • The absence of the indicates that no choice is required.
 • Alpha-numeric characters in place of indicate that no other alternatives are available.

HOW TO BUILD A MODEL NUMBER

- A** Select basic model.
- B** Select pull option.
 S6 - Beveled pull Black
 S5 - Beveled pull Satin Chrome
- C** Select base option.
 4CW - 4 black casters
 4GB - 4 black glides
- D** Select top laminate surface.
 Refer to the **Product Color Options** page in this price list.
- E** Select edge color.
 Refer to the **Product Color Options** page in this price list.
- F** Select shell color.
 Refer to the **Product Color Options** page in this price list.
- G** Select front door color.

Refer to the **Product Color Options** page in this price list.

- H** Select lock option.
 KS - Key standard - 2 locks
 NLC - No lock core - 2 locks

I Select lock color.
 Refer to the **Product Color Options** page in this price list.

FINISH INFORMATION

Additional Laminate Offering

KI offers laminates beyond those offered in the standard offering. Laminates that are currently available in the program can be viewed in KI product specification tools. Requests to add laminates to the program can be submitted via the product modification request process. Please note, requests to add laminates to the program must include the laminate manufacturer's name, color/pattern number, and finish code. Edge options are limited to standard edge colors. If a matching edge is required, this will need to be requested through the product modification request process and may be subject to additional costs. Due to varying manufacturing processes and quality issues with some laminates, some requests may be denied. Extended lead times and minimum order quantities may apply on orders containing special laminates. Contact the product modification team for questions or additional information regarding special laminates and pricing.

SPECIAL SERVICES

Special Carton Marking

With specially marked information N/C

Shipping

Ships assembled, FOB Pembroke, ON K8A 0E1, freight excluded. Freight class 100.

Specifications and prices are subject to change without prior notice.

Ruckus® Storage (Freight Excluded Pricing)

Totes with Laminate Top



Ruckus® Storage (Freight Excluded Pricing)

Totes with Laminate Top

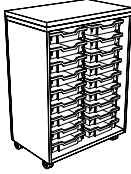
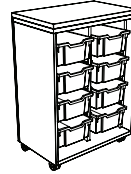
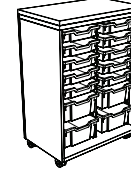
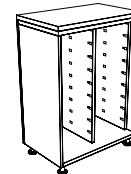
MODEL	W x D x H	MODEL NUMBER					Approx. Packaged Weight	Freight Excluded Pricing	Laminate Grade 2 add to list price
		Basic Model	Base	Top Color	Edge Color	Shell Color			
 <p>Tall 2-Column Unit, Open with Laminate Top and (18)3" Totes</p> <ul style="list-style-type: none"> Laminate top (1-1/4" with 74P edge) Single-Face only Totes included are translucent with no lid (not included on the 'empty' model) Unit ships assembled, including totes and rail sets; glides/casters are field installed 	30 x 18 x 42"	RKT301842OPT/3T	<input type="checkbox"/> <input type="checkbox"/> <input type="checkbox"/>		<input type="checkbox"/> <input type="checkbox"/> <input type="checkbox"/>	<input type="checkbox"/>	131.2#	\$ 1749	\$ 19
RCKT									
 <p>Tall 2-Column Unit, Open with Laminate Top and (8)6" Totes</p> <ul style="list-style-type: none"> Laminate top (1-1/4" with 74P edge) Single-Face only Totes included are translucent with no lid (not included on the 'empty' model) Unit ships assembled, including totes and rail sets; glides/casters are field installed 	30 x 18 x 42"	RKT301842OPT/6T	<input type="checkbox"/> <input type="checkbox"/> <input type="checkbox"/>		<input type="checkbox"/> <input type="checkbox"/> <input type="checkbox"/>	<input type="checkbox"/>	123.7#	\$ 1578	\$ 19
RCKT									
 <p>Tall 2-Column Unit, Open with Laminate Top and (10)3" and (4)6" Totes</p> <ul style="list-style-type: none"> Laminate top (1-1/4" with 74P edge) Single-Face only Totes included are translucent with no lid (not included on the 'empty' model) Unit ships assembled, including totes and rail sets; glides/casters are field installed 	30 x 18 x 42"	RKT301842OPT/36T	<input type="checkbox"/> <input type="checkbox"/> <input type="checkbox"/>		<input type="checkbox"/> <input type="checkbox"/> <input type="checkbox"/>	<input type="checkbox"/>	128.6#	\$ 1681	\$ 19
RCKT									
 <p>Tall 2-Column Unit, Open with Laminate Top-Empty</p> <ul style="list-style-type: none"> Laminate top (1-1/4" with 74P edge) Single-Face only Tote and rail sets must be ordered separately and installed on-site Unit ships assembled; glides/casters are field installed 	30 x 18 x 42"	RKT301842OPT/XT	<input type="checkbox"/> <input type="checkbox"/> <input type="checkbox"/>		<input type="checkbox"/> <input type="checkbox"/> <input type="checkbox"/>	<input type="checkbox"/>	110.5#	\$ 1345	\$ 19
RCKT									

A **B** **C** **D** **E**

HOW TO ORDER

- Indicate the following information on order form:
- Quantity of each item.
 - Model number, including options. See "How To Build a Model Number".
 - Any special service required.

Note: • The indicates that a choice is required.
 • The absence of the indicates that no choice is required.
 • Alpha-numeric characters in place of indicate that no other alternatives are available.

HOW TO BUILD A MODEL NUMBER

- A** Select basic model.
- B** Select base option.

4CW	- 4 black casters
4GB	- 4 black glides
- C** Select top laminate surface. Refer to the **Product Color Options** page in this price list.
- D** Select edge color. Refer to the **Product Color Options** page in this price list.
- E** Select shell color. Refer to the **Product Color Options** page in this price list.

FINISH INFORMATION

Additional Laminate Offering
 KI offers laminates beyond those offered in the standard offering. Laminates that are currently available in the program can be viewed in KI product specification tools. Requests to add laminates to the program can be submitted via the product modification request process. Please note, requests to add laminates to the program must include the laminate manufacturer's name, color/pattern number, and finish code. Edge options are limited to standard edge colors. If a matching edge is required, this will need to be requested through the product modification request process and may be subject to additional costs. Due to varying manufacturing processes and quality issues with some laminates, some requests may be denied. Extended lead times and minimum order quantities may apply on orders containing special laminates. Contact the product modification team for questions or additional information regarding special laminates and pricing.

SPECIAL SERVICES

Special Carton Marking

With specially marked information N/C

Shipping
 Ships assembled, FOB Pembroke, ON K8A 0E1, freight excluded. Freight class 100.

Specifications and prices are subject to change without prior notice.

Ruckus® Storage (Freight Excluded Pricing)

Totes with Laminate Top



Ruckus® Storage (Freight Excluded Pricing)

Totes with Laminate Top

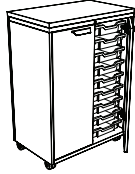
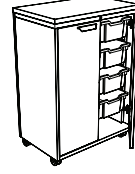
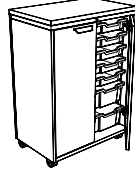
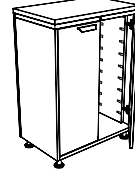
MODEL	W x D x H	MODEL NUMBER										Approx. Packaged Weight	Freight Excluded Pricing	Laminate Grade 2 add to list price
		Basic Model	Pull Option	Base	Top Color	Edge Color	Shell Color	Door Color	Lock Option	Lock Color				
 <p>Tall 2-Column Unit with Laminate Top, Doors and (18)3" Totes</p> <ul style="list-style-type: none"> Laminate top (1-1/4" with 74P edge) Single-Face only Totes included are translucent with no lid (not included on the 'empty' model) Unit ships assembled, including totes and rail sets; glides/casters are field installed Secure locking doors 	30 x 18 x 42"	RKT301842DRT/3T	<input type="checkbox"/>	<input type="checkbox"/>	<input type="checkbox"/>	<input type="checkbox"/>	<input type="checkbox"/>	<input type="checkbox"/>	<input type="checkbox"/>	<input type="checkbox"/>	<input type="checkbox"/>	157.2#	\$ 1987	\$ 19
 <p>Tall 2-Column Unit with Laminate Top, Doors and (8)6" Totes</p> <ul style="list-style-type: none"> Laminate top (1-1/4" with 74P edge) Single-Face only Totes included are translucent with no lid (not included on the 'empty' model) Unit ships assembled, including totes and rail sets; glides/casters are field installed Secure locking doors 	30 x 18 x 42"	RKT301842DRT/6T	<input type="checkbox"/>	<input type="checkbox"/>	<input type="checkbox"/>	<input type="checkbox"/>	<input type="checkbox"/>	<input type="checkbox"/>	<input type="checkbox"/>	<input type="checkbox"/>	<input type="checkbox"/>	149.7#	\$ 1829	\$ 19
 <p>Tall 2-Column Unit with Laminate Top, Doors and (10)3" and (4)6" Totes</p> <ul style="list-style-type: none"> Laminate top (1-1/4" with 74P edge) Single-Face only Totes included are translucent with no lid (not included on the 'empty' model) Unit ships assembled, including totes and rail sets; glides/casters are field installed Secure locking doors 	30 x 18 x 42"	RKT301842DRT/36T	<input type="checkbox"/>	<input type="checkbox"/>	<input type="checkbox"/>	<input type="checkbox"/>	<input type="checkbox"/>	<input type="checkbox"/>	<input type="checkbox"/>	<input type="checkbox"/>	<input type="checkbox"/>	154.6#	\$ 1935	\$ 19
 <p>Tall 2-Column Unit with Laminate Top and Doors-Empty</p> <ul style="list-style-type: none"> Laminate top (1-1/4" with 74P edge) Single-Face only Tote and rail sets must be ordered separately and installed on-site Unit ships assembled; glides/casters are field installed Secure locking doors 	30 x 18 x 42"	RKT301842DRT/XT	<input type="checkbox"/>	<input type="checkbox"/>	<input type="checkbox"/>	<input type="checkbox"/>	<input type="checkbox"/>	<input type="checkbox"/>	<input type="checkbox"/>	<input type="checkbox"/>	<input type="checkbox"/>	136.5#	\$ 1600	\$ 19

A B C D E F G H I

HOW TO ORDER

- Indicate the following information on order form:
- Quantity of each item.
 - Model number, including options. See "How To Build a Model Number".
 - Any special service required.

Note: • The indicates that a choice is required.
 • The absence of the indicates that no choice is required.
 • Alpha-numeric characters in place of indicate that no other alternatives are available.

HOW TO BUILD A MODEL NUMBER

- A** Select basic model.
- B** Select pull option.
S6 - Beveled pull Black
S5 - Beveled pull Satin Chrome
- C** Select base option.
4CW - 4 black casters
4GB - 4 black glides
- D** Select top laminate surface.
 Refer to the **Product Color Options** page in this price list.
- E** Select edge color.
 Refer to the **Product Color Options** page in this price list.
- F** Select shell color.
 Refer to the **Product Color Options** page in this price list.
- G** Select front door color.

Refer to the **Product Color Options** page in this price list.

- H** Select lock option.
KS - Key standard - 2 locks
NLC - No lock core - 2 locks

I Select lock color.
 Refer to the **Product Color Options** page in this price list.

FINISH INFORMATION

Additional Laminate Offering

KI offers laminates beyond those offered in the standard offering. Laminates that are currently available in the program can be viewed in KI product specification tools. Requests to add laminates to the program can be submitted via the product modification request process. Please note, requests to add laminates to the program must include the laminate manufacturer's name, color/pattern number, and finish code. Edge options are limited to standard edge colors. If a matching edge is required, this will need to be requested through the product modification request process and may be subject to additional costs. Due to varying manufacturing processes and quality issues with some laminates, some requests may be denied. Extended lead times and minimum order quantities may apply on orders containing special laminates. Contact the product modification team for questions or additional information regarding special laminates and pricing.

SPECIAL SERVICES

Special Carton Marking

With specially marked information N/C

Shipping

Ships assembled, FOB Pembroke, ON K8A 0E1, freight excluded. Freight class 100.

Specifications and prices are subject to change without prior notice.

Ruckus® Storage (Freight Excluded Pricing)

Totes with Laminate Top



Ruckus® Storage (Freight Excluded Pricing)

Totes with Laminate Top

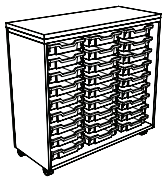
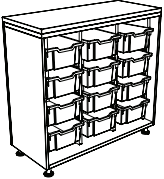
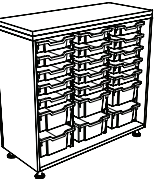
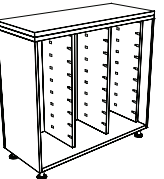
MODEL	W x D x H	MODEL NUMBER					Approx. Packaged Weight	Freight Excluded Pricing	Laminate Grade 2 add to list price
		Basic Model	Base	Top Color	Edge Color	Shell Color			
 <p>Tall 3-Column Unit, Open with Laminate top and (27)3" Totes</p> <ul style="list-style-type: none"> Laminate top (1-1/4" with 74P edge) Single-Face only Totes included are translucent with no lid (not included on the 'empty' model) Unit ships assembled, including totes and rail sets; glides/casters are field installed 	44 x 18 x 42"	RKT441842OPT/3T	<input type="checkbox"/>	<input type="checkbox"/>	<input type="checkbox"/>	<input type="checkbox"/>	185.1#	\$ 2166	\$ 19
RCKT									
 <p>Tall 3-Column Unit, Open with Laminate top and (12)6" Totes</p> <ul style="list-style-type: none"> Laminate top (1-1/4" with 74P edge) Single-Face only Totes included are translucent with no lid (not included on the 'empty' model) Unit ships assembled, including totes and rail sets; glides/casters are field installed 	44 x 18 x 42"	RKT441842OPT/6T	<input type="checkbox"/>	<input type="checkbox"/>	<input type="checkbox"/>	<input type="checkbox"/>	173.8#	\$ 1944	\$ 19
RCKT									
 <p>Tall 3-Column Unit, Open with Laminate top and (15)3" and (6)6" Totes</p> <ul style="list-style-type: none"> Laminate top (1-1/4" with 74P edge) Single-Face only Totes included are translucent with no lid (not included on the 'empty' model) Unit ships assembled, including totes and rail sets; glides/casters are field installed 	44 x 18 x 42"	RKT441842OPT/36T	<input type="checkbox"/>	<input type="checkbox"/>	<input type="checkbox"/>	<input type="checkbox"/>	175.1#	\$ 2099	\$ 19
RCKT									
 <p>Tall 3-Column Unit, Open with Laminate top-Empty</p> <ul style="list-style-type: none"> Laminate top (1-1/4" with 74P edge) Single-Face only Tote and rail sets must be ordered separately and installed on-site Unit ships assembled; glides/casters are field installed 	44 x 18 x 42"	RKT441842OPT/XT	<input type="checkbox"/>	<input type="checkbox"/>	<input type="checkbox"/>	<input type="checkbox"/>	154.0#	\$ 1591	\$ 19
RCKT									

A **B** **C** **D** **E**

HOW TO ORDER

- Indicate the following information on order form:
- Quantity of each item.
 - Model number, including options. See "How To Build a Model Number".
 - Any special service required.

Note:

- The indicates that a choice is required.
- The absence of the indicates that no choice is required.
- Alpha-numeric characters in place of indicate that no other alternatives are available.

HOW TO BUILD A MODEL NUMBER

- A** Select basic model.
- B** Select base option.

4CW	- 4 black casters
4GB	- 4 black glides
- C** Select top laminate surface. Refer to the **Product Color Options** page in this price list.
- D** Select edge color. Refer to the **Product Color Options** page in this price list.
- E** Select shell color. Refer to the **Product Color Options** page in this price list.

FINISH INFORMATION

Additional Laminate Offering
 KI offers laminates beyond those offered in the standard offering. Laminates that are currently available in the program can be viewed in KI product specification tools. Requests to add laminates to the program can be submitted via the product modification request process. Please note, requests to add laminates to the program must include the laminate manufacturer's name, color/pattern number, and finish code. Edge options are limited to standard edge colors. If a matching edge is required, this will need to be requested through the product modification request process and may be subject to additional costs. Due to varying manufacturing processes and quality issues with some laminates, some requests may be denied. Extended lead times and minimum order quantities may apply on orders containing special laminates. Contact the product modification team for questions or additional information regarding special laminates and pricing.

SPECIAL SERVICES

Special Carton Marking

With specially marked information N/C

Shipping
 Ships assembled, FOB Pembroke, ON K8A 0E1, freight excluded. Freight class 100.

Specifications and prices are subject to change without prior notice.

Ruckus® Storage (Freight Excluded Pricing)

Totes with Laminate Top



Ruckus® Storage (Freight Excluded Pricing)

Totes with Laminate Top

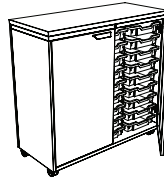
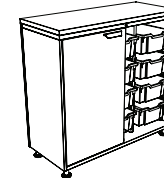
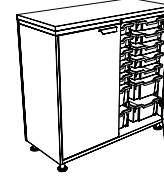
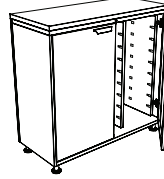
MODEL	W x D x H	MODEL NUMBER										Approx. Packaged Weight	Freight Excluded Pricing	Laminate Grade 2 add to list price
		Basic Model	Pull Option	Base	Top Color	Edge Color	Shell Color	Door Color	Lock Option	Lock Color				
 <p>Tall 3-Column Unit with Doors, Laminate Top and (27)3” Totes</p> <ul style="list-style-type: none"> Laminate top (1-1/4” with 74P edge) Single-Face only Totes included are translucent with no lid (not included on the 'empty' model) Unit ships assembled, including totes and rail sets; glides/casters are field installed Secure locking doors 	44 x 18 x 42”	RKT441842DRT/3T	<input type="checkbox"/>	<input type="checkbox"/>	<input type="checkbox"/>	<input type="checkbox"/>	<input type="checkbox"/>	<input type="checkbox"/>	<input type="checkbox"/>	<input type="checkbox"/>	<input type="checkbox"/>	211.1#	\$ 2444	\$ 19
 <p>Tall 3-Column Unit with Doors, Laminate Top and (12)6” Totes</p> <ul style="list-style-type: none"> Laminate top (1-1/4” with 74P edge) Single-Face only Totes included are translucent with no lid (not included on the 'empty' model) Unit ships assembled, including totes and rail sets; glides/casters are field installed Secure locking doors 	44 x 18 x 42”	RKT441842DRT/6T	<input type="checkbox"/>	<input type="checkbox"/>	<input type="checkbox"/>	<input type="checkbox"/>	<input type="checkbox"/>	<input type="checkbox"/>	<input type="checkbox"/>	<input type="checkbox"/>	<input type="checkbox"/>	199.8#	\$ 2239	\$ 19
 <p>Tall 3-Column Unit with Doors, Laminate Top and (15)3” and (6)6” Totes</p> <ul style="list-style-type: none"> Laminate top (1-1/4” with 74P edge) Single-Face only Totes included are translucent with no lid (not included on the 'empty' model) Unit ships assembled, including totes and rail sets; glides/casters are field installed Secure locking doors 	44 x 18 x 42”	RKT441842DRT/36T	<input type="checkbox"/>	<input type="checkbox"/>	<input type="checkbox"/>	<input type="checkbox"/>	<input type="checkbox"/>	<input type="checkbox"/>	<input type="checkbox"/>	<input type="checkbox"/>	<input type="checkbox"/>	201.1#	\$ 2397	\$ 19
 <p>Tall 3-Column Unit with Doors and Laminate Top-Empty</p> <ul style="list-style-type: none"> Laminate top (1-1/4” with 74P edge) Single-Face only Tote and rail sets must be ordered separately and installed on-site Unit ships assembled; glides/casters are field installed Secure locking doors 	44 x 18 x 42”	RKT441842DRT/XT	<input type="checkbox"/>	<input type="checkbox"/>	<input type="checkbox"/>	<input type="checkbox"/>	<input type="checkbox"/>	<input type="checkbox"/>	<input type="checkbox"/>	<input type="checkbox"/>	<input type="checkbox"/>	180.0#	\$ 1879	\$ 19

A B C D E F G H I

HOW TO ORDER

- Indicate the following information on order form:
- Quantity of each item.
 - Model number, including options. See “How To Build a Model Number”.
 - Any special service required.

Note: • The indicates that a choice is required.

- The absence of the indicates that no choice is required.
- Alpha-numeric characters in place of indicate that no other alternatives are available.

HOW TO BUILD A MODEL NUMBER

- A** Select basic model.
- B** Select pull option.
 - S6** - Beveled pull Black
 - S5** - Beveled pull Satin Chrome
- C** Select base option.
 - 4CW** - 4 black casters
 - 4GB** - 4 black glides
- D** Select top laminate surface. Refer to the **Product Color Options** page in this price list.
- E** Select edge color. Refer to the **Product Color Options** page in this price list.
- F** Select shell color. Refer to the **Product Color Options** page in this price list.
- G** Select front door color.

Refer to the **Product Color Options** page in this price list.

- H** Select lock option.
 - KS** - Key standard - 2 locks
 - NLC** - No lock core - 2 locks

I Select lock color. Refer to the **Product Color Options** page in this price list.

FINISH INFORMATION

Additional Laminate Offering

KI offers laminates beyond those offered in the standard offering. Laminates that are currently available in the program can be viewed in KI product specification tools. Requests to add laminates to the program can be submitted via the product modification request process. Please note, requests to add laminates to the program must include the laminate manufacturer's name, color/pattern number, and finish code. Edge options are limited to standard edge colors. If a matching edge is required, this will need to be requested through the product modification request process and may be subject to additional costs. Due to varying manufacturing processes and quality issues with some laminates, some requests may be denied. Extended lead times and minimum order quantities may apply on orders containing special laminates. Contact the product modification team for questions or additional information regarding special laminates and pricing.

SPECIAL SERVICES

Special Carton Marking

With specially marked information N/C

Shipping

Ships assembled, FOB Pembroke, ON K8A 0E1, freight excluded. Freight class 100.

Specifications and prices are subject to change without prior notice.

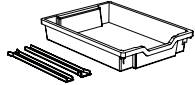
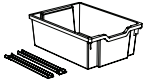
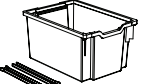
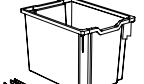
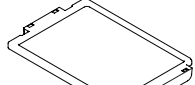

MODEL	W x D	MODEL NUMBER		Approx. Packaged Weight	Freight Excluded Pricing
		Basic Model			
 <p>3"H Totes Kit (includes 6 translucent totes and rail sets)</p>		RKA3TKIT6		8.2#	\$ 176
RCKA					
 <p>6"H Totes Kit (includes 6 translucent totes and rail sets)</p>		RKA6TKIT6		11.2#	\$ 203
RCKA					
 <p>9"H Totes Kit (includes 6 translucent totes and rail sets)</p>		RKA9TKIT6		13.3#	\$ 257
RCKA					
 <p>12"H Totes Kit (includes 6 translucent totes and rail sets)</p>		RKA12TKIT6		17.5#	\$ 284
RCKA					
 <p>Tote Lids Kit (includes 6 translucent tote lids)</p>		RKALIDKIT6		3.3#	\$ 109
RCKA					

A

HOW TO ORDER

- Indicate the following information on order form:
1. Quantity of each item.
 2. Model number, including options. See "How To Build a Model Number".
 3. Any special service required.

- Note:
- The indicates that a choice is required.
 - The absence of the indicates that no choice is required.
 - Alpha-numeric characters in place of indicate that no other alternatives are available.

HOW TO BUILD A MODEL NUMBER

- A** Select basic model.

SPECIAL SERVICES

Special Carton Marking



With specially marked information N/C

Shipping

Ships assembled, FOB Pembroke, ON K8A 0E1, freight excluded. Freight class 100.

Specifications and prices are subject to change without prior notice.

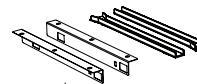
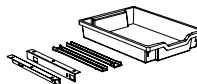

MODEL	MODEL NUMBER		Approx. Packaged Weight	Freight Excluded Pricing
	Basic Model	Paint Color		
 RCKA Tote Storage Rails Only Kit (includes 12 rail sets) RCKA	RKARAILKIT12		2.60#	\$ 115
 RCKA Undersurface Rail kit (tote specified separately) • Mounting brackets are Starlight Silver Metallic • For installing undersurface without predrilled holes RCKA	RKAUSRKIT1		1.00#	\$ 49
 RCKA Undersurface Rail kit, with 3" Tote • Mounting brackets are Starlight Silver Metallic • For installing undersurface without predrilled holes RCKA	RKAUSR3TKIT1		2.20#	\$ 78
 RCKA Tote Storage Removeable Steel Shelf with Rail Set RCKA	RKATSSHELF	<input type="checkbox"/>	4.50#	\$ 48

A

B

HOW TO ORDER

- Indicate the following information on order form:
- Quantity of each item.
 - Model number, including options. See "How To Build a Model Number".
 - Any special service required.

Note:

- The indicates that a choice is required.
- The absence of the indicates that no choice is required.
- Alpha-numeric characters in place of indicate that no other alternatives are available.

HOW TO BUILD A MODEL NUMBER

- A** Select basic model.
- B** Select paint color. Refer to the **Product Color Options** page in this price list.

SPECIAL SERVICES

Special Carton Marking





With specially marked information N/C

Shipping

Ships assembled, FOB Pembroke, ON K8A 0E1, freight excluded. Freight class 100.

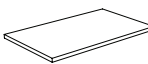
Specifications and prices are subject to change without prior notice.



	MODEL	W x D	MODEL NUMBER			Approx. Packaged Weight	Freight Excluded Pricing	Laminate Grade 2 add to list price
			Basic Model	Top Color	Edge Color			
 RCKA	Tote Storage Top 30Wx18D • Laminate top (1-1/4" with 74P edge)	30 x 18"	RKATTOP3018	<input type="checkbox"/> <input type="checkbox"/>	<input type="checkbox"/> <input type="checkbox"/>	19.4#	\$ 201	\$ 19
 RCKA	Tote Storage Top 44Wx18D • Laminate top (1-1/4" with 74P edge)	44 x 18"	RKATTOP4418	<input type="checkbox"/> <input type="checkbox"/>	<input type="checkbox"/> <input type="checkbox"/>	28.4#	\$ 259	\$ 19
 RCKA	Ruckus Storage Caster Kit (4 Black Casters)		RKA4CWKIT			2.0#	\$ 27	N/A
 RCKA	Ruckus Storage Glide Kit (4 Black Glides)		RKA4GBKIT			1.5#	\$ 34	N/A

A **B** **C**

HOW TO ORDER

- Indicate the following information on order form:
- Quantity of each item.
 - Model number, including options. See "How To Build a Model Number".
 - Any special service required.

Note:

- The indicates that a choice is required.
- The absence of the indicates that no choice is required.
- Alpha-numeric characters in place of indicate that no other alternatives are available.

HOW TO BUILD A MODEL NUMBER

- A** Select basic model.
- B** Select top laminate surface. Refer to the **Product Color Options** page in this price list.
- C** Select edge color. Refer to the **Product Color Options** page in this price list.

SPECIAL SERVICES

Special Carton Marking

With specially marked information N/C

Shipping

Ships assembled, FOB Pembroke, ON K8A 0E1, freight excluded. Freight class 100.

Specifications and prices are subject to change without prior notice.



MODEL	Features	MODEL NUMBER		Approx. Packaged Weight	Freight Excluded Pricing
		Basic Model			
AC905	P-Series Keys • Double bit design • Range of 200 different core/key numbers available • Must specify lock number(s) requested when ordering cut key or lock core/key sets	Lock Core/2 Key Set - Satin Chrome	2.KP20522.SC	0.40#	\$ 16
		Lock Core/2 Key Set - Black	2.KP20522	0.40#	16
		Master Key	2.KP20550	0.20#	12
		Extractor Key	2.KP20551	0.20#	12
		Blank Key	2.KP20552	0.20#	3
		Cut Key	2.KP20557	0.20#	4

A

HOW TO ORDER

- Indicate the following information on order form:
- Quantity of each item.
 - Model number, including options. See "How To Build a Model Number".
 - Any special service required.

- Note:
- The indicates that a choice is required.
 - The absence of the indicates that no choice is required.
 - Alpha-numeric characters in place of indicate that no other alternatives are available.

HOW TO BUILD A MODEL NUMBER

- A** Select basic model.

SPECIAL SERVICES

Special Carton Marking



With specially marked information N/C

Shipping

Ships assembled, FOB Pembroke, ON K8A 0E1, freight prepaid. Freight class 70.

Specifications and prices are subject to change without prior notice.

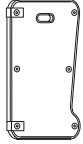
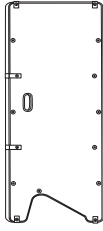

		MODEL NUMBER			
MODEL		Basic Model	Approx. Packaged Weight	Freight Excluded Pricing	
 RKWB	Ruckus Whiteboard, Small • Dry-erase and tackable acoustic PET felt surfaces • Magnetic dots for attaching markers & other accessories • Leather straps for hanging on wall track and holding papers • Unique palette shape improves handling & positioning • Integrated handle. Hangs on undersurface bag hooks	16 x 12"	RKWB1612	2.0#	\$ 108
 RKWB	Ruckus Whiteboard, Medium • Dry-erase and tackable acoustic PET felt surfaces • Magnetic dots for attaching markers & other accessories • Leather straps for hanging on wall track and holding papers • Unique palette shape improves handling & positioning • Integrated handle. Hangs on undersurface bag hooks	22 X 18"	RKWB2218	3.5#	\$ 151
 RKWB	Ruckus Whiteboard, Large • Dry-erase and tackable acoustic PET felt surfaces • Magnetic dots for attaching markers & other accessories • Leather straps for hanging on wall track and holding papers • Integrated handle	31 x 23"	RKWB3123	6.0#	\$ 281
 RKWB	Ruckus Whiteboard, XL • Dry-erase and tackable acoustic PET felt surfaces • Magnetic dots for attaching markers & other accessories • Leather straps for hanging on wall track and holding papers • Integrated handle • Notched base permits foot clearance	71 x 23"	RKWB7123	16.0#	\$ 619

A

HOW TO ORDER

- Indicate the following information on order form:
- Quantity of each item.
 - Model number, including options. See "How To Build a Model Number".
 - Any special service required.

Note:

- The indicates that a choice is required.
- The absence of the indicates that no choice is required.
- Alpha-numeric characters in place of indicate that no other alternatives are available.

HOW TO BUILD A MODEL NUMBER

A Select basic model.

SPECIAL SERVICES

Special Carton Marking





With specially marked information N/C

Shipping

Ships assembled, FOB Bondue1, WI 54107, freight excluded. Freight class 125.

Specifications and prices are subject to change without prior notice.

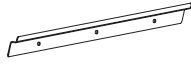

MODEL	MODEL NUMBER			Approx. Packaged Weight	Freight Excluded Pricing
	Basic Model	Paint Color	Under Table Storage		
 RKWA Pivot Dock • Holds Medium and Large Ruckus Whiteboards upright for display or to create privacy. • Allows user to pivot Whiteboards 360 degrees • Clamps onto desk and table surfaces 3/4" to 1-1/4" thick	RKWADOCK	<input type="checkbox"/>		1.0#	\$ 43
 RKWA Widget • Stands Ruckus whiteboards up into a privacy or display mode • Props Ruckus whiteboards up into a drafting angle • Holds one standard and two fine tip sized markers (markers not included) • 100% post-consumer recycled PET felt	RKWAWIDGET			0.5#	\$ 9
 RKWA Wall Track 48" • Allows Ruckus whiteboards to be displayed or stored vertically on exterior walls • 48" length holds 1 to 3 Ruckus Whiteboards depending on size • Mounting hardware not included	RKWAWALLTRCK	<input type="checkbox"/>		1.5#	\$ 65
 RKWM Undersurface Hook • 1/4" wire rod, chrome finish • Field Installable, includes 2 screws • Holds whiteboards, bags and purses	RKWMUSHOOK			0.2#	\$ 9
 RKWA Mobile Display Cart • Two-sided cart, with two heights of display shelves • Display shelves hold Ruckus whiteboards of any size • Center shelf for storing ruckus whiteboards • Locking caster base • Shown with removable tote storage	RKWACART	<input type="checkbox"/>	<input type="checkbox"/>	100.0#	\$ 1512

A **B** **C**

HOW TO ORDER

- Indicate the following information on order form:
- Quantity of each item.
 - Model number, including options. See "How To Build a Model Number".
 - Any special service required.

Note: • The indicates that a choice is required.
 • The absence of the indicates that no choice is required.
 • Alpha-numeric characters in place of indicate that no other alternatives are available.

HOW TO BUILD A MODEL NUMBER

- A** Select basic model.
- B** Select paint color. Refer to the **Product Color Options** page in this price list.
- C** Select under table storage.
NB - No book storage
RT - Removable storage tote; add \$47

SPECIAL SERVICES



Special Carton Marking

With specially marked information N/C

Shipping
 Ships assembled, FOB Bondue1, WI 54107, freight excluded. Freight class 70.

Specifications and prices are subject to change without prior notice.



MODEL	Features	H	MODEL NUMBER					Approx. Packaged Weight	Delivered Pricing Unupholstered	Delivered Pricing Fabric Grade 1 & C.O.M.	Delivered Pricing Fabric Grade 2	Delivered Pricing Fabric Grade 3 & Group 2V Vinyl	Delivered Pricing Pallas Fabric Group P0	Delivered Pricing Pallas Fabric Group P1	Delivered Pricing Pallas Fabric Group P2	Delivered Pricing Pallas Fabric Group P3	Delivered Pricing Pallas Fabric Group P4
			Basic Model	Poly Color	Frame Color	Glide Option	Upholstery Color										
 <p>Four-Leg Chair with Glides</p> <ul style="list-style-type: none"> Model does not stack Ships fully assembled, packaged 1 chair per carton 	Polypropylene	15"	RK1100H15NB	<input type="checkbox"/> <input type="checkbox"/> <input type="checkbox"/>	<input type="checkbox"/>	<input type="checkbox"/> <input type="checkbox"/> <input type="checkbox"/>											
	Polypropylene	18"	RK1100H18NB	<input type="checkbox"/> <input type="checkbox"/> <input type="checkbox"/>	<input type="checkbox"/>	<input type="checkbox"/> <input type="checkbox"/> <input type="checkbox"/>											
RK11																	
 <p>Four-Leg Chair with Glides</p> <ul style="list-style-type: none"> Model does not stack Ships fully assembled, packaged 1 chair per carton 	Upholstered Seat	15"	RK1200H15NB	<input type="checkbox"/> <input type="checkbox"/> <input type="checkbox"/>	<input type="checkbox"/>	<input type="checkbox"/> <input type="checkbox"/> <input type="checkbox"/>	<input type="checkbox"/> <input type="checkbox"/> <input type="checkbox"/> <input type="checkbox"/> <input type="checkbox"/>		N/A	\$ 420	\$ 431	\$ 453	\$ 467	\$ 535	\$ 557	\$ 585	\$ 624
	Upholstered Seat	18"	RK1200H18NB	<input type="checkbox"/> <input type="checkbox"/> <input type="checkbox"/>	<input type="checkbox"/>	<input type="checkbox"/> <input type="checkbox"/> <input type="checkbox"/>	<input type="checkbox"/> <input type="checkbox"/> <input type="checkbox"/> <input type="checkbox"/> <input type="checkbox"/>		N/A	423	437	458	471	541	561	589	629
RK12																	

A B C D E

HOW TO ORDER

- Indicate the following information on order form:
- Quantity of each item.
 - Model number, including options. See "How To Build a Model Number".
 - Any special service required.

Note:

- The indicates that a choice is required.
- The absence of the indicates that no choice is required.
- Alpha-numeric characters in place of indicate that no other alternatives are available.

HOW TO BUILD A MODEL NUMBER

- A** Select basic model.
- B** Select poly color. Refer to the **Product Color Options** page in this price list.
- C** Select frame finish. Refer to the **Product Color Options** page in this price list.
- D** Select glide option.

GFT	- Felt glides
GPL	- Nylon plastic glides
GSL	- Steel glides
- E** Select upholstery grade/color. Refer to ki.com/fabrics

UPHOLSTERY INFORMATION

C.O.M. Upholstery
 C.O.M. requirement for 10 chairs or less with upholstered seat or upholstered seat and back is 3/4 yard per chair of 54" wide nondirectional fabric. For orders of 11 or more with upholstered seat and back and for complete information on ordering C.O.M. see "Ordering C.O.M., C.O.V. and C.O.L." section.

SPECIAL SERVICES

Special Carton Marking



With specially marked information N/C

Shipping

Ships assembled, FOB Green Bay, WI 54302, freight prepaid. Freight class 250.

Specifications and prices are subject to change without prior notice.



MODEL	Features	H	MODEL NUMBER					Approx. Packaged Weight	Delivered Pricing Unupholstered	Delivered Pricing Fabric Grade 1 & C.O.M.	Delivered Pricing Fabric Grade 2	Delivered Pricing Fabric Grade 3 & Group 2V Vinyl	Delivered Pricing Pallas Fabric Group P0	Delivered Pricing Pallas Fabric Group P1	Delivered Pricing Pallas Fabric Group P2	Delivered Pricing Pallas Fabric Group P3	Delivered Pricing Pallas Fabric Group P4	
			Basic Model	Poly Color	Frame Color	Caster Type	Upholstery Color											
 Four-Leg Chair with Casters • Model does not stack • Ships fully assembled, packaged 1 chair per carton	Polypropylene	15"	RK2100H15NB	<input type="checkbox"/> <input type="checkbox"/> <input type="checkbox"/>	<input type="checkbox"/>	<input type="checkbox"/> <input type="checkbox"/> <input type="checkbox"/>		29.50#	\$ 284									
	Polypropylene	18"	RK2100H18NB	<input type="checkbox"/> <input type="checkbox"/> <input type="checkbox"/>	<input type="checkbox"/>	<input type="checkbox"/> <input type="checkbox"/> <input type="checkbox"/>		30.50#	288									
RK21	 Four-Leg Chair with Casters • Model does not stack • Ships fully assembled, packaged 1 chair per carton	Upholstered Seat	15"	RK2200H15NB	<input type="checkbox"/> <input type="checkbox"/> <input type="checkbox"/>	<input type="checkbox"/>	<input type="checkbox"/> <input type="checkbox"/> <input type="checkbox"/>	<input type="checkbox"/> <input type="checkbox"/> <input type="checkbox"/> <input type="checkbox"/>	32.00#	N/A	\$ 438	\$ 450	\$ 472	\$ 486	\$ 554	\$ 576	\$ 602	\$ 642
RK22		Upholstered Seat	18"	RK2200H18NB	<input type="checkbox"/> <input type="checkbox"/> <input type="checkbox"/>	<input type="checkbox"/>	<input type="checkbox"/> <input type="checkbox"/> <input type="checkbox"/>	<input type="checkbox"/> <input type="checkbox"/> <input type="checkbox"/> <input type="checkbox"/>	33.00#	N/A	442	453	476	489	559	580	607	646
				A	B	C	D	E										

HOW TO ORDER

- Indicate the following information on order form:
- Quantity of each item.
 - Model number, including options. See "How To Build a Model Number".
 - Any special service required.

Note:

- The indicates that a choice is required.
- The absence of the indicates that no choice is required.
- Alpha-numeric characters in place of indicate that no other alternatives are available.

HOW TO BUILD A MODEL NUMBER

- A** Select basic model.
- B** Select poly color. Refer to the **Product Color Options** page in this price list.
- C** Select frame finish. Refer to the **Product Color Options** page in this price list.
- D** Select caster type.

CCC	- Carpet casters
CHC	- Hard floor casters
- E** Select upholstery grade/color. Refer to ki.com/fabrics

UPHOLSTERY INFORMATION

C.O.M. Upholstery
 C.O.M. requirement for 10 chairs or less with upholstered seat or upholstered seat and back is 3/4 yard per chair of 54" wide nondirectional fabric. For orders of 11 or more with upholstered seat and back and for complete information on ordering C.O.M. see "Ordering C.O.M., C.O.V. and C.O.L." section.

SPECIAL SERVICES

Special Carton Marking

With specially marked information N/C

Shipping

Ships **assembled, FOB Green Bay, WI 54302, freight prepaid.** Freight class 250.

Specifications and prices are subject to change without prior notice.



Ruckus® Seating (Delivered Pricing)

Stack Chair with Glides



Ruckus® Seating (Delivered Pricing)

Stack Chair with Glides

MODEL	Features	H	MODEL NUMBER					Approx. Packaged Weight	Delivered Pricing Unupholstered	Delivered Pricing Fabric Grade 1 & C.O.M.	Delivered Pricing Fabric Grade 2	Delivered Pricing Fabric Grade 3 & Group 2V Vinyl	Delivered Pricing Pallas Fabric Group P0	Delivered Pricing Pallas Fabric Group P1	Delivered Pricing Pallas Fabric Group P2	Delivered Pricing Pallas Fabric Group P3	Delivered Pricing Pallas Fabric Group P4	
			Basic Model	Poly Color	Frame Color	Glide Option	Upholstery Color											
 Stack Chair with Glides • Ships fully assembled, packaged 1 chair per carton • 15" chair stacks 3 high • 18" chair stacks 4 high	Polypropylene	15"	RKU100H15NB	<input type="checkbox"/> <input type="checkbox"/> <input type="checkbox"/>	<input type="checkbox"/>	<input type="checkbox"/> <input type="checkbox"/> <input type="checkbox"/>		34.00#	\$ 339									
	Polypropylene	18"	RKU100H18NB	<input type="checkbox"/> <input type="checkbox"/> <input type="checkbox"/>	<input type="checkbox"/>	<input type="checkbox"/> <input type="checkbox"/> <input type="checkbox"/>		35.00#	346									
RKU1	 Stack Chair with Glides • Ships assembled, packaged 1 chair per carton • 15" chair stacks 2 high • 18" chair stacks 3 high	Upholstered Seat	15"	RKU200H15NB	<input type="checkbox"/> <input type="checkbox"/> <input type="checkbox"/>	<input type="checkbox"/>	<input type="checkbox"/> <input type="checkbox"/> <input type="checkbox"/>	<input type="checkbox"/> <input type="checkbox"/> <input type="checkbox"/> <input type="checkbox"/>	36.50#	N/A	\$ 487	\$ 497	\$ 518	\$ 530	\$ 597	\$ 615	\$ 642	\$ 680
Upholstered Seat		18"	RKU200H18NB	<input type="checkbox"/> <input type="checkbox"/> <input type="checkbox"/>	<input type="checkbox"/>	<input type="checkbox"/> <input type="checkbox"/> <input type="checkbox"/>	<input type="checkbox"/> <input type="checkbox"/> <input type="checkbox"/> <input type="checkbox"/>	37.50#	N/A	490	501	524	534	600	620	645	683	

A **B** **C** **D** **E**

HOW TO ORDER

- Indicate the following information on order form:
- Quantity of each item.
 - Model number, including options. See "How To Build a Model Number".
 - Any special service required.

Note: • The indicates that a choice is required.
 • The absence of the indicates that no choice is required.
 • Alpha-numeric characters in place of indicate that no other alternatives are available.

HOW TO BUILD A MODEL NUMBER

- A** Select basic model.
- B** Select poly color. Refer to the **Product Color Options** page in this price list.
- C** Select frame finish. Refer to the **Product Color Options** page in this price list.
- D** Select glide option.

GFT	- Felt glides
GPL	- Nylon plastic glides
GSL	- Steel glides
- E** Select upholstery grade/color. Refer to ki.com/fabrics

UPHOLSTERY INFORMATION

C.O.M. Upholstery
 C.O.M. requirement for 10 chairs or less with upholstered seat or upholstered seat and back is 3/4 yard per chair of 54" wide nondirectional fabric. For orders of 11 or more with upholstered seat and back and for complete information on ordering C.O.M. see "Ordering C.O.M., C.O.V. and C.O.L." section.

SPECIAL SERVICES

Special Carton Marking

With specially marked information N/C

Shipping

Ships **assembled, FOB Green Bay, WI 54302, freight prepaid.** Freight class 125.

Specifications and prices are subject to change without prior notice.



Ruckus® Seating (Delivered Pricing)

Stack Chair with Glides



Ruckus® Seating (Delivered Pricing)

Stack Chair with Glides

MODEL	Features	H	MODEL NUMBER						Approx. Packaged Weight	Delivered Pricing Unupholstered	Delivered Pricing Fabric Grade 1 & C.O.M.	Delivered Pricing Fabric Grade 2	Delivered Pricing Fabric Grade 3 & Group 2V Vinyl	Delivered Pricing Pallas Fabric Group P0	Delivered Pricing Pallas Fabric Group P1	Delivered Pricing Pallas Fabric Group P2	Delivered Pricing Pallas Fabric Group P3	Delivered Pricing Pallas Fabric Group P4	
			Basic Model	Poly Color	Frame Color	Bookbag Rack Color	Glide Option	Upholstery Color											
 Stack Chair with Glides and Bookbag Rack • Ships fully assembled, packaged 1 chair per carton • 15" chair stacks 3 high • 18" chair stacks 4 high	Polypropylene	15"	RKU100H15BR	<input type="checkbox"/> <input type="checkbox"/> <input type="checkbox"/>	<input type="checkbox"/>	<input type="checkbox"/> <input type="checkbox"/> <input type="checkbox"/> <input type="checkbox"/>	<input type="checkbox"/> <input type="checkbox"/>		37.00#	\$ 415									
	Polypropylene	18"	RKU100H18BR	<input type="checkbox"/> <input type="checkbox"/> <input type="checkbox"/>	<input type="checkbox"/>	<input type="checkbox"/> <input type="checkbox"/> <input type="checkbox"/> <input type="checkbox"/>	<input type="checkbox"/> <input type="checkbox"/>		38.00#	420									
RKU1	 Stack Chair with Glides and Bookbag Rack • Ships fully assembled, packaged 1 chair per carton • 15" chair stacks 2 high • 18" chair stacks 3 high	Upholstered Seat	15"	RKU200H15BR	<input type="checkbox"/> <input type="checkbox"/> <input type="checkbox"/>	<input type="checkbox"/>	<input type="checkbox"/> <input type="checkbox"/> <input type="checkbox"/> <input type="checkbox"/>	<input type="checkbox"/> <input type="checkbox"/>	<input type="checkbox"/> <input type="checkbox"/> <input type="checkbox"/> <input type="checkbox"/>	39.50#	N/A	\$ 560	\$ 572	\$ 594	\$ 605	\$ 671	\$ 690	\$ 717	\$ 753
		Upholstered Seat	18"	RKU200H18BR	<input type="checkbox"/> <input type="checkbox"/> <input type="checkbox"/>	<input type="checkbox"/>	<input type="checkbox"/> <input type="checkbox"/> <input type="checkbox"/> <input type="checkbox"/>	<input type="checkbox"/> <input type="checkbox"/>	<input type="checkbox"/> <input type="checkbox"/> <input type="checkbox"/> <input type="checkbox"/>	40.50#	N/A	582	594	614	625	691	712	739	776
RKU2				A	B	C	D	E	F										

HOW TO ORDER

- Indicate the following information on order form:
- Quantity of each item.
 - Model number, including options. See "How To Build a Model Number".
 - Any special service required.

Note: • The indicates that a choice is required.
 • The absence of the indicates that no choice is required.
 • Alpha-numeric characters in place of indicate that no other alternatives are available.

HOW TO BUILD A MODEL NUMBER

- A** Select basic model.
- B** Select poly color. Refer to the **Product Color Options** page in this price list.
- C** Select frame finish. Refer to the **Product Color Options** page in this price list.
- D** Select bookbag rack color. Refer to the **Product Color Options** page in this price list.
- E** Select glide option.

GFT	- Felt glides
GPL	- Nylon plastic glides
GSL	- Steel glides
- F** Select upholstery grade/color. Refer to ki.com/fabrics

UPHOLSTERY INFORMATION

C.O.M. Upholstery
 C.O.M. requirement for 10 chairs or less with upholstered seat or upholstered seat and back is 3/4 yard per chair of 54" wide nondirectional fabric. For orders of 11 or more with upholstered seat and back and for complete information on ordering C.O.M. see "Ordering C.O.M., C.O.V. and C.O.L." section.

SPECIAL SERVICES

Special Carton Marking

With specially marked information N/C

Shipping

Ships **assembled, FOB Green Bay, WI 54302, freight prepaid.** Freight class 125.

Specifications and prices are subject to change without prior notice.



Ruckus® Seating (Delivered Pricing)

Stack Chair with Casters



Ruckus® Seating (Delivered Pricing)

Stack Chair with Casters

MODEL	Features	H	MODEL NUMBER					Approx. Packaged Weight	Delivered Pricing Unupholstered	Delivered Pricing Fabric Grade 1 & C.O.M.	Delivered Pricing Fabric Grade 2	Delivered Pricing Fabric Grade 3 & Group 2V Vinyl	Delivered Pricing Pallas Fabric Group P0	Delivered Pricing Pallas Fabric Group P1	Delivered Pricing Pallas Fabric Group P2	Delivered Pricing Pallas Fabric Group P3	Delivered Pricing Pallas Fabric Group P4	
			Basic Model	Poly Color	Frame Color	Caster Type	Upholstery Color											
 <p>Stack Chair with Casters • Ships fully assembled, packaged 1 chair per carton • 15" chair stacks 3 high • 18" chair stacks 4 high</p>	Polypropylene	15"	RKV100H15NB	<input type="checkbox"/> <input type="checkbox"/> <input type="checkbox"/>	<input type="checkbox"/>	<input type="checkbox"/> <input type="checkbox"/> <input type="checkbox"/>												
	Polypropylene	18"	RKV100H18NB	<input type="checkbox"/> <input type="checkbox"/> <input type="checkbox"/>	<input type="checkbox"/>	<input type="checkbox"/> <input type="checkbox"/> <input type="checkbox"/>	34.50#	\$ 357										
							35.50#	362										
RKV1																		
 <p>Stack Chair with Casters • Ships fully assembled, packaged 1 chair per carton • 15" chair stacks 2 high • 18" chair stacks 3 high</p>	Upholstered Seat	15"	RKV200H15NB	<input type="checkbox"/> <input type="checkbox"/> <input type="checkbox"/>	<input type="checkbox"/>	<input type="checkbox"/> <input type="checkbox"/> <input type="checkbox"/>	<input type="checkbox"/> <input type="checkbox"/> <input type="checkbox"/> <input type="checkbox"/>	37.00#	N/A	\$ 502	\$ 514	\$ 535	\$ 547	\$ 612	\$ 634	\$ 658	\$ 695	
	Upholstered Seat	18"	RKV200H18NB	<input type="checkbox"/> <input type="checkbox"/> <input type="checkbox"/>	<input type="checkbox"/>	<input type="checkbox"/> <input type="checkbox"/> <input type="checkbox"/>	<input type="checkbox"/> <input type="checkbox"/> <input type="checkbox"/>	38.00#	N/A	505	518	540	550	617	637	661	701	
RKV2																		

A **B** **C** **D** **E**

HOW TO ORDER

- Indicate the following information on order form:
- Quantity of each item.
 - Model number, including options. See "How To Build a Model Number".
 - Any special service required.

Note: • The indicates that a choice is required.
 • The absence of the indicates that no choice is required.
 • Alpha-numeric characters in place of indicate that no other alternatives are available.

HOW TO BUILD A MODEL NUMBER

- A** Select basic model.
- B** Select poly color. Refer to the **Product Color Options** page in this price list.
- C** Select frame finish. Refer to the **Product Color Options** page in this price list.
- D** Select caster type.

CHC	- Hard floor casters
CCC	- Carpet casters
- E** Select upholstery grade/color. Refer to ki.com/fabrics

UPHOLSTERY INFORMATION

C.O.M. Upholstery
 C.O.M. requirement for 10 chairs or less with upholstered seat or upholstered seat and back is 3/4 yard per chair of 54" wide nondirectional fabric. For orders of 11 or more with upholstered seat and back and for complete information on ordering C.O.M. see "Ordering C.O.M., C.O.V. and C.O.L." section.

SPECIAL SERVICES

Special Carton Marking

With specially marked information N/C

Shipping

Ships **assembled, FOB Green Bay, WI 54302, freight prepaid.** Freight class 125.

Specifications and prices are subject to change without prior notice.



Ruckus® Seating (Delivered Pricing)

Stack Chair with Casters



Ruckus® Seating (Delivered Pricing)

Stack Chair with Casters

MODEL	Features	H	MODEL NUMBER						Approx. Packaged Weight	Delivered Pricing Unupholstered	Delivered Pricing Fabric Grade 1 & C.O.M.	Delivered Pricing Fabric Grade 2	Delivered Pricing Fabric Grade 3 & Group 2V Vinyl	Delivered Pricing Pallas Fabric Group P0	Delivered Pricing Pallas Fabric Group P1	Delivered Pricing Pallas Fabric Group P2	Delivered Pricing Pallas Fabric Group P3	Delivered Pricing Pallas Fabric Group P4	
			Basic Model	Poly Color	Frame Color	Bookbag Rack Color	Caster Type	Upholstery Color											
 Stack Chair with Casters and Bookbag Rack • Ships fully assembled, packaged 1 chair per carton • 15" chair stacks 3 high • 18" chair stacks 4 high	Polypropylene	15"	RKV100H15BR	<input type="checkbox"/> <input type="checkbox"/> <input type="checkbox"/>	<input type="checkbox"/>	<input type="checkbox"/> <input type="checkbox"/> <input type="checkbox"/> <input type="checkbox"/>	<input type="checkbox"/> <input type="checkbox"/>		37.50#	\$ 431									
	Polypropylene	18"	RKV100H18BR	<input type="checkbox"/> <input type="checkbox"/> <input type="checkbox"/>	<input type="checkbox"/>	<input type="checkbox"/> <input type="checkbox"/> <input type="checkbox"/> <input type="checkbox"/>	<input type="checkbox"/> <input type="checkbox"/>		38.50#	437									
RKV1	 Stack Chair with Casters and Bookbag Rack • Ships fully assembled, packaged 1 chair per carton • 15" chair stacks 2 high • 18" chair stacks 3 high	Upholstered Seat	15"	RKV200H15BR	<input type="checkbox"/> <input type="checkbox"/> <input type="checkbox"/>	<input type="checkbox"/>	<input type="checkbox"/> <input type="checkbox"/> <input type="checkbox"/> <input type="checkbox"/>	<input type="checkbox"/> <input type="checkbox"/>	<input type="checkbox"/> <input type="checkbox"/> <input type="checkbox"/> <input type="checkbox"/>	40.00#	N/A	\$ 577	\$ 587	\$ 609	\$ 622	\$ 688	\$ 708	\$ 733	\$ 770
Upholstered Seat		18"	RKV200H18BR	<input type="checkbox"/> <input type="checkbox"/> <input type="checkbox"/>	<input type="checkbox"/>	<input type="checkbox"/> <input type="checkbox"/> <input type="checkbox"/> <input type="checkbox"/>	<input type="checkbox"/> <input type="checkbox"/>	<input type="checkbox"/> <input type="checkbox"/> <input type="checkbox"/> <input type="checkbox"/>	41.00#	N/A	582	594	614	625	691	712	739	776	
RKV2				A	B	C	D	E	F										

HOW TO ORDER

- Indicate the following information on order form:
- Quantity of each item.
 - Model number, including options. See "How To Build a Model Number".
 - Any special service required.

Note: • The indicates that a choice is required.
 • The absence of the indicates that no choice is required.
 • Alpha-numeric characters in place of indicate that no other alternatives are available.

HOW TO BUILD A MODEL NUMBER

- A** Select basic model.
- B** Select poly color. Refer to the **Product Color Options** page in this price list.
- C** Select frame finish. Refer to the **Product Color Options** page in this price list.
- D** Select bookbag rack color. Refer to the **Product Color Options** page in this price list.
- E** Select caster type.
CHC - Hard floor casters
CCC - Carpet casters
- F** Select upholstery grade/color. Refer to ki.com/fabrics

UPHOLSTERY INFORMATION

C.O.M. Upholstery
 C.O.M. requirement for 10 chairs or less with upholstered seat or upholstered seat and back is 3/4 yard per chair of 54" wide nondirectional fabric. For orders of 11 or more with upholstered seat and back and for complete information on ordering C.O.M. see "Ordering C.O.M., C.O.V. and C.O.L." section.

SPECIAL SERVICES

Special Carton Marking
 With specially marked information N/C

Shipping
 Ships assembled, FOB Green Bay, WI 54302, freight prepaid. Freight class 125.

Specifications and prices are subject to change without prior notice.



Ruckus® Seating (Delivered Pricing)

Stool with Glides



Ruckus® Seating (Delivered Pricing)

Stool with Glides

MODEL	Features	H	MODEL NUMBER					Approx. Packaged Weight	Delivered Pricing Unupholstered	Delivered Pricing Fabric Grade 1 & C.O.M.	Delivered Pricing Fabric Grade 2	Delivered Pricing Fabric Grade 3 & Group 2V Vinyl	Delivered Pricing Pallas Fabric Group P0	Delivered Pricing Pallas Fabric Group P1	Delivered Pricing Pallas Fabric Group P2	Delivered Pricing Pallas Fabric Group P3	Delivered Pricing Pallas Fabric Group P4
			Basic Model	Poly Color	Frame Color	Glide Option	Upholstery Color										
 <p>Stool with Glides and No Bookbag Rack • Ships fully assembled, packaged 1 chair per carton • Stacks 3 high</p>	Polypropylene	24"	RK4100H24NB	<input type="checkbox"/>	<input type="checkbox"/>	<input type="checkbox"/>		42.00#									
	Polypropylene	30"	RK4100H30NB	<input type="checkbox"/>	<input type="checkbox"/>	<input type="checkbox"/>		43.00#	\$ 429								
 <p>Stool with Glides and No Bookbag Rack • Ships fully assembled, packaged 1 chair per carton • Stacks 3 high</p>	Upholstered Seat	24"	RK4200H24NB	<input type="checkbox"/>	<input type="checkbox"/>	<input type="checkbox"/>	<input type="checkbox"/>	44.50#	N/A	\$ 582	\$ 594	\$ 617	\$ 629	\$ 697	\$ 719	\$ 746	\$ 787
	Upholstered Seat	30"	RK4200H30NB	<input type="checkbox"/>	<input type="checkbox"/>	<input type="checkbox"/>	<input type="checkbox"/>	45.50#	N/A	597	608	632	643	713	734	762	801

A **B** **C** **D** **E**

HOW TO ORDER

- Indicate the following information on order form:
- Quantity of each item.
 - Model number, including options. See "How To Build a Model Number".
 - Any special service required.

Note:

- The indicates that a choice is required.
- The absence of the indicates that no choice is required.
- Alpha-numeric characters in place of indicate that no other alternatives are available.

HOW TO BUILD A MODEL NUMBER

- A** Select basic model.
- B** Select poly color. Refer to the **Product Color Options** page in this price list.
- C** Select frame finish. Refer to the **Product Color Options** page in this price list.
- D** Select glide option.

GFT	- Felt glides
GPL	- Nylon plastic glides
GSL	- Steel glides
- E** Select upholstery grade/color. Refer to ki.com/fabrics

UPHOLSTERY INFORMATION

C.O.M. Upholstery
 C.O.M. requirement for 10 chairs or less with upholstered seat or upholstered seat and back is 3/4 yard per chair of 54" wide nondirectional fabric. For orders of 11 or more with upholstered seat and back and for complete information on ordering C.O.M. see "Ordering C.O.M., C.O.V. and C.O.L." section.

SPECIAL SERVICES

Special Carton Marking

With specially marked information N/C

Shipping

Ships **assembled, FOB Green Bay, WI 54302, freight prepaid.** Freight class 250.

Specifications and prices are subject to change without prior notice.

Ruckus® Seating (Delivered Pricing)

Stool with Glides



Ruckus® Seating (Delivered Pricing)

Stool with Glides

MODEL	Features	H	MODEL NUMBER						Approx. Packaged Weight	Delivered Pricing Unupholstered	Delivered Pricing Fabric Grade 1 & C.O.M.	Delivered Pricing Fabric Grade 2	Delivered Pricing Fabric Grade 3 & Group 2V Vinyl	Delivered Pricing Pallas Fabric Group P0	Delivered Pricing Pallas Fabric Group P1	Delivered Pricing Pallas Fabric Group P2	Delivered Pricing Pallas Fabric Group P3	Delivered Pricing Pallas Fabric Group P4
			Basic Model	Poly Color	Frame Color	Bookbag Rack Color	Glide Option	Upholstery Color										
<p>Stool with Glides and Bookbag Rack</p> <ul style="list-style-type: none"> Ships fully assembled, packaged 1 chair per carton Stacks 3 high 	Polypropylene	24"	RK4100H24BR	<input type="checkbox"/>	<input type="checkbox"/>	<input type="checkbox"/>	<input type="checkbox"/>	45.00#	\$ 504									
	Polypropylene	30"	RK4100H30BR	<input type="checkbox"/>	<input type="checkbox"/>	<input type="checkbox"/>	<input type="checkbox"/>	46.00#	521									
<p>Stool with Glides and Bookbag Rack</p> <ul style="list-style-type: none"> Ships fully assembled, packaged 1 chair per carton Stacks 3 high 	Upholstered Seat	24"	RK4200H24BR	<input type="checkbox"/>	<input type="checkbox"/>	<input type="checkbox"/>	<input type="checkbox"/>	47.50#	N/A	\$ 660	\$ 672	\$ 695	\$ 708	\$ 777	\$ 799	\$ 826	\$ 864	
	Upholstered Seat	30"	RK4200H30BR	<input type="checkbox"/>	<input type="checkbox"/>	<input type="checkbox"/>	<input type="checkbox"/>	48.50#	N/A	673	686	709	721	791	812	838	880	

A **B** **C** **D** **E** **F**

HOW TO ORDER

- Indicate the following information on order form:
- Quantity of each item.
 - Model number, including options. See "How To Build a Model Number".
 - Any special service required.

Note:

- The indicates that a choice is required.
- The absence of the indicates that no choice is required.
- Alpha-numeric characters in place of indicate that no other alternatives are available.

HOW TO BUILD A MODEL NUMBER

- A** Select basic model.
- B** Select poly color. Refer to the **Product Color Options** page in this price list.
- C** Select frame finish. Refer to the **Product Color Options** page in this price list.
- D** Select bookbag rack color. Refer to the **Product Color Options** page in this price list.
- E** Select glide option.

GFT	- Felt glides
GPL	- Nylon plastic glides
GSL	- Steel glides
- F** Select upholstery grade/color. Refer to ki.com/fabrics

UPHOLSTERY INFORMATION

C.O.M. Upholstery
 C.O.M. requirement for 10 chairs or less with upholstered seat or upholstered seat and back is 3/4 yard per chair of 54" wide nondirectional fabric. For orders of 11 or more with upholstered seat and back and for complete information on ordering C.O.M. see "Ordering C.O.M., C.O.V. and C.O.L." section.

SPECIAL SERVICES

Special Carton Marking

With specially marked information N/C

Shipping

Ships **assembled, FOB Green Bay, WI 54302, freight prepaid.** Freight class 250.

Specifications and prices are subject to change without prior notice.



Ruckus® Seating (Delivered Pricing)

Stool with Casters



Ruckus® Seating (Delivered Pricing)

Stool with Casters

MODEL	Features	H	MODEL NUMBER					Approx. Packaged Weight	Delivered Pricing Unupholstered	Delivered Pricing Fabric Grade 1 & C.O.M.	Delivered Pricing Fabric Grade 2	Delivered Pricing Fabric Grade 3 & Group 2V Vinyl	Delivered Pricing Pallas Fabric Group P0	Delivered Pricing Pallas Fabric Group P1	Delivered Pricing Pallas Fabric Group P2	Delivered Pricing Pallas Fabric Group P3	Delivered Pricing Pallas Fabric Group P4
			Basic Model	Poly Color	Frame Color	Glide Option	Upholstery Color										
 Stool with Casters and No Bookbag Rack • Ships fully assembled, packaged 1 chair per carton • Stacks 3 high	Polypropylene	24"	RKN100H24NB	<input type="checkbox"/> <input type="checkbox"/> <input type="checkbox"/>	<input type="checkbox"/>	<input type="checkbox"/> <input type="checkbox"/>		42.00#	\$ 456								
	Polypropylene	30"	RKN100H30NB	<input type="checkbox"/> <input type="checkbox"/> <input type="checkbox"/>	<input type="checkbox"/>	<input type="checkbox"/> <input type="checkbox"/>		43.00#	471								
 Stool with Casters and No Bookbag Rack • Ships fully assembled, packaged 1 chair per carton • Stacks 3 high	Upholstered Seat	24"	RKN200H24NB	<input type="checkbox"/> <input type="checkbox"/> <input type="checkbox"/>	<input type="checkbox"/>	<input type="checkbox"/> <input type="checkbox"/>	<input type="checkbox"/> <input type="checkbox"/> <input type="checkbox"/> <input type="checkbox"/>	44.50#	N/A	\$ 608	\$ 622	\$ 644	\$ 656	\$ 726	\$ 746	\$ 775	\$ 814
	Upholstered Seat	30"	RKN200H30NB	<input type="checkbox"/> <input type="checkbox"/> <input type="checkbox"/>	<input type="checkbox"/>	<input type="checkbox"/> <input type="checkbox"/>	<input type="checkbox"/> <input type="checkbox"/> <input type="checkbox"/> <input type="checkbox"/>	45.50#	N/A	624	636	659	671	741	762	790	829

A **B** **C** **D** **E**

HOW TO ORDER

- Indicate the following information on order form:
- Quantity of each item.
 - Model number, including options. See "How To Build a Model Number".
 - Any special service required.

Note: • The indicates that a choice is required.
 • The absence of the indicates that no choice is required.
 • Alpha-numeric characters in place of indicate that no other alternatives are available.

HOW TO BUILD A MODEL NUMBER

- A** Select basic model.
- B** Select poly color. Refer to the **Product Color Options** page in this price list.
- C** Select frame finish. Refer to the **Product Color Options** page in this price list.
- D** Select caster option.

CHC	- Hard floor casters
CCC	- Carpet casters
- E** Select upholstery grade/color. Refer to ki.com/fabrics

UPHOLSTERY INFORMATION

C.O.M. Upholstery
 C.O.M. requirement for 10 chairs or less with upholstered seat or upholstered seat and back is 3/4 yard per chair of 54" wide nondirectional fabric. For orders of 11 or more with upholstered seat and back and for complete information on ordering C.O.M. see "Ordering C.O.M., C.O.V. and C.O.L." section.

SPECIAL SERVICES

Special Carton Marking

With specially marked information N/C

Shipping

Ships **assembled, FOB Green Bay, WI 54302, freight prepaid.** Freight class 250.

Specifications and prices are subject to change without prior notice.



Ruckus® Seating (Delivered Pricing)

Stool with Casters



Ruckus® Seating (Delivered Pricing)

Stool with Casters

MODEL	Features	H	MODEL NUMBER						Approx. Packaged Weight	Delivered Pricing Unupholstered	Delivered Pricing Fabric Grade 1 & C.O.M.	Delivered Pricing Fabric Grade 2	Delivered Pricing Fabric Grade 3 & Group 2V Vinyl	Delivered Pricing Pallas Fabric Group P0	Delivered Pricing Pallas Fabric Group P1	Delivered Pricing Pallas Fabric Group P2	Delivered Pricing Pallas Fabric Group P3	Delivered Pricing Pallas Fabric Group P4
			Basic Model	Poly Color	Frame Color	Bookbag Rack Color	Glide Option	Upholstery Color										
 <p>Stool with Casters and Bookbag Rack • Ships fully assembled, packaged 1 chair per carton • Stacks 3 high</p>	Polypropylene	24"	RKN100H24BR	<input type="checkbox"/> <input type="checkbox"/> <input type="checkbox"/>	<input type="checkbox"/>	<input type="checkbox"/> <input type="checkbox"/> <input type="checkbox"/> <input type="checkbox"/>	<input type="checkbox"/> <input type="checkbox"/>		45.00#	\$ 533								
	Polypropylene	30"	RKN100H30BR	<input type="checkbox"/> <input type="checkbox"/> <input type="checkbox"/>	<input type="checkbox"/>	<input type="checkbox"/> <input type="checkbox"/> <input type="checkbox"/> <input type="checkbox"/>	<input type="checkbox"/> <input type="checkbox"/>		46.00#	548								
 <p>Stool with Casters and Bookbag Rack • Ships fully assembled, packaged 1 chair per carton • Stacks 3 high</p>	Upholstered Seat	24"	RKN200H24BR	<input type="checkbox"/> <input type="checkbox"/> <input type="checkbox"/>	<input type="checkbox"/>	<input type="checkbox"/> <input type="checkbox"/> <input type="checkbox"/> <input type="checkbox"/>	<input type="checkbox"/> <input type="checkbox"/>	<input type="checkbox"/> <input type="checkbox"/> <input type="checkbox"/> <input type="checkbox"/>	47.50#	N/A	\$ 689	\$ 700	\$ 724	\$ 737	\$ 804	\$ 827	\$ 852	\$ 893
	Upholstered Seat	30"	RKN200H30BR	<input type="checkbox"/> <input type="checkbox"/> <input type="checkbox"/>	<input type="checkbox"/>	<input type="checkbox"/> <input type="checkbox"/> <input type="checkbox"/> <input type="checkbox"/>	<input type="checkbox"/> <input type="checkbox"/>	<input type="checkbox"/> <input type="checkbox"/> <input type="checkbox"/> <input type="checkbox"/>	48.50#	N/A	701	713	738	749	820	839	865	907

A **B** **C** **D** **E** **F**

HOW TO ORDER

- Indicate the following information on order form:
- Quantity of each item.
 - Model number, including options. See "How To Build a Model Number".
 - Any special service required.

Note: • The indicates that a choice is required.
 • The absence of the indicates that no choice is required.
 • Alpha-numeric characters in place of indicate that no other alternatives are available.

HOW TO BUILD A MODEL NUMBER

- A** Select basic model.
- B** Select poly color.
Refer to the **Product Color Options** page in this price list.
- C** Select frame finish.
Refer to the **Product Color Options** page in this price list.
- D** Select bookbag rack color.
Refer to the **Product Color Options** page in this price list.
- E** Select caster option.

CHC	- Hard floor casters
CCC	- Carpet casters
- F** Select upholstery grade/color.
Refer to ki.com/fabrics

UPHOLSTERY INFORMATION

C.O.M. Upholstery
 C.O.M. requirement for 10 chairs or less with upholstered seat or upholstered seat and back is 3/4 yard per chair of 54" wide nondirectional fabric. For orders of 11 or more with upholstered seat and back and for complete information on ordering C.O.M. see "Ordering C.O.M., C.O.V. and C.O.L." section.

SPECIAL SERVICES

Special Carton Marking



With specially marked information N/C

Shipping

Ships **assembled, FOB Green Bay, WI 54302, freight prepaid.** Freight class 250.

Specifications and prices are subject to change without prior notice.



MODEL	Features	MODEL NUMBER					Approx. Packaged Weight	Delivered Pricing Unupholstered	Delivered Pricing Fabric Grade 1 & C.O.M.	Delivered Pricing Fabric Grade 2	Delivered Pricing Fabric Grade 3 & Group 2V Vinyl	Delivered Pricing Pallas Fabric Group P0	Delivered Pricing Pallas Fabric Group P1	Delivered Pricing Pallas Fabric Group P2	Delivered Pricing Pallas Fabric Group P3	Delivered Pricing Pallas Fabric Group P4
		Basic Model	Poly Color	Frame Color	Caster Type	Upholstery Color										
 Task Chair • Ships KD, packaged 1 chair per carton • Utilizes 28" 5-blade base	Polypropylene	RK5100	<input type="checkbox"/> <input type="checkbox"/>	<input type="checkbox"/>	<input type="checkbox"/> <input type="checkbox"/>		36.00#	\$ 434								
 Task Chair • Ships KD, packaged 1 chair per carton • Utilizes 28" 5-blade base	Upholstered Seat	RK5200	<input type="checkbox"/> <input type="checkbox"/>	<input type="checkbox"/>	<input type="checkbox"/> <input type="checkbox"/>	<input type="checkbox"/> <input type="checkbox"/> <input type="checkbox"/> <input type="checkbox"/>	38.50#	N/A	\$ 578	\$ 589	\$ 611	\$ 623	\$ 689	\$ 709	\$ 734	\$ 773

A **B** **C** **D** **E**

HOW TO ORDER

- Indicate the following information on order form:
- Quantity of each item.
 - Model number, including options. See "How To Build a Model Number".
 - Any special service required.

Note:

- The indicates that a choice is required.
- The absence of the indicates that no choice is required.
- Alpha-numeric characters in place of indicate that no other alternatives are available.

HOW TO BUILD A MODEL NUMBER

- A** Select basic model.
- B** Select poly color. Refer to the **Product Color Options** page in this price list.
- C** Select frame color. Refer to the **Product Color Options** page in this price list.
- D** Select caster or glide type.

CHC	- Hard floor casters
CCC	- Carpet casters
GBG	- Bell glide
- E** Select upholstery grade/color. Refer to ki.com/fabrics

UPHOLSTERY INFORMATION

C.O.M. Upholstery
 C.O.M. requirement for 10 chairs or less with upholstered seat or upholstered seat and back is 3/4 yard per chair of 54" wide nondirectional fabric. For orders of 11 or more with upholstered seat and back and for complete information on ordering C.O.M. see "Ordering C.O.M., C.O.V. and C.O.L." section.

SPECIAL SERVICES

Special Carton Marking

With specially marked information N/C

Shipping
 Ships **partially assembled, FOB Green Bay, WI 54302, freight prepaid.** Freight class 250.

Specifications and prices are subject to change without prior notice.

Ruckus® Mobile Lectern (Delivered Pricing)

Mobile Lectern



Ruckus® Mobile Lectern (Delivered Pricing)

Mobile Lectern

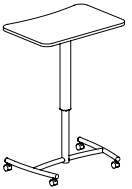
MODEL	MODEL NUMBER								Approx. Packaged Weight	Delivered Pricing	Laminate Grade 2 add to list price
	Basic Model	Storage Accessories	Base	Top Color	Edge Color	Base Color	Book Basket Color	Acrylic Modesty Panel Color			
 <p>Mobile Lectern</p> <ul style="list-style-type: none"> • 20" x 30" Laminate worksurface with curved front only • Ships fully assembled, packaged 1 lectern per carton • 28-3/4" to 42-3/4" height range • When chrome is selected the lower frame will be chrome and the upper column assembly will be starlight silver • Lectern is always on casters 	RUW20E	<input type="checkbox"/> <input type="checkbox"/> <input type="checkbox"/> <input type="checkbox"/>	<input type="checkbox"/> <input type="checkbox"/>	<input type="checkbox"/> <input type="checkbox"/>	<input type="checkbox"/> <input type="checkbox"/>	<input type="checkbox"/> <input type="checkbox"/>	<input type="checkbox"/> <input type="checkbox"/> <input type="checkbox"/> <input type="checkbox"/>		59.00#	\$ 1179	\$ 19
	RUX20E	<input type="checkbox"/> <input type="checkbox"/> <input type="checkbox"/> <input type="checkbox"/>	<input type="checkbox"/> <input type="checkbox"/>	<input type="checkbox"/> <input type="checkbox"/>	<input type="checkbox"/> <input type="checkbox"/>	<input type="checkbox"/> <input type="checkbox"/>	<input type="checkbox"/> <input type="checkbox"/> <input type="checkbox"/> <input type="checkbox"/>	<input type="checkbox"/> <input type="checkbox"/>	64.00#	\$ 1477	\$ 19

RUW20

RUX20

A **B** **C** **D** **E** **F** **G** **H**

HOW TO ORDER

- Indicate the following information on order form:
- Quantity of each item.
 - Model number, including options. See "How To Build a Model Number".
 - Any special service required.

Note:

- The indicates that a choice is required.
- The absence of the indicates that no choice is required.
- Alpha-numeric characters in place of indicate that no other alternatives are available.

HOW TO BUILD A MODEL NUMBER

- A** Select basic model.
- B** Select storage/accessories.
- NB** - No book storage
 - BH** - Bag hooks; add \$11
 - BR** - Book basket; add \$72
 - CL** - Swiveling cup holder - left side; add \$64
 - CR** - Swiveling cup holder - right side; add \$64
 - BHCL** - Book bag hook-right side & cup holder-left side; add \$70
 - BHCR** - Book bag hook-left side & cup holder-right side; add \$70
 - BRCL** - Book basket & cup holder - left side; add \$136
 - BRCR** - Book basket & cup holder - right side; add \$136
- C** Select base option.
- CHC** - Hard floor casters
 - CCC** - Carpet casters

- D** Select top laminate surface. Refer to the **Product Color Options** page in this price list.
- E** Select edge color. Refer to the **Product Color Options** page in this price list.
- F** Select base color. Refer to the **Product Color Options** page in this price list.
- G** Select book basket color. Refer to the **Product Color Options** page in this price list. When Book basket/rack & cup holder (BRCL or BRRCR) is selected the cup holder is always starlight silver metallic.
- H** Select acrylic modesty panel color. Refer to the **Product Color Options** page in this price list.

FINISH INFORMATION

Additional Laminate Offering

KI offers laminates beyond those offered in the standard offering. Laminates that are currently available in the program can be viewed in KI product specification tools. Requests to add laminates to the program can be submitted via the product modification request process. Please note, requests to add laminates to the program must include the laminate manufacturer's name, color/pattern number, and finish code. Edge options are limited to standard edge colors. If a matching edge is required, this will need to be requested through the product modification request process and may be subject to additional costs. Due to varying manufacturing processes and quality issues with some laminates, some requests may be denied. Extended lead times and minimum order quantities may apply on orders containing special laminates. Contact the product modification team for questions or additional information regarding special laminates and pricing.

SPECIAL SERVICES

Special Carton Marking

With specially marked information N/C

Shipping
Ships assembled, FOB Bonduei, WI 54107, freight prepaid. Freight class 125.

Specifications and prices are subject to change without prior notice.

Ruckus® Mobile Lectern (Delivered Pricing)

Mobile Lectern



Ruckus® Mobile Lectern (Delivered Pricing)

Mobile Lectern

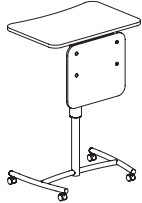
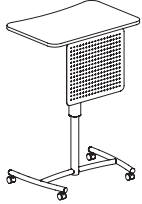
MODEL	MODEL NUMBER									Approx. Packaged Weight	Delivered Pricing	Laminate Grade 2 add to list price	
	Basic Model	Storage Accessories	Base	Top Color	Edge Color	Base Color	Book Basket Color	Felt Modesty Panel Color	Steel Modesty Panel Color				
 <p>Mobile Lectern with Felt Modesty Panel</p> <ul style="list-style-type: none"> • 20" x 30" Laminate worksurface with curved front only • Ships fully assembled, packaged 1 lectern per carton • 28-3/4" to 42-3/4" height range • When chrome is selected the lower frame will be chrome and the upper column assembly will be starlight silver • Lectern is always on casters • Includes felt modesty panel 	RUX22E	<input type="checkbox"/> <input type="checkbox"/> <input type="checkbox"/> <input type="checkbox"/>	<input type="checkbox"/> <input type="checkbox"/>	<input type="checkbox"/> <input type="checkbox"/>	<input type="checkbox"/> <input type="checkbox"/>	<input type="checkbox"/>	<input type="checkbox"/> <input type="checkbox"/> <input type="checkbox"/> <input type="checkbox"/>	<input type="checkbox"/> <input type="checkbox"/>		63.00#	\$ 1448	\$ 19	
 <p>Mobile Lectern with Steel Modesty Panel</p> <ul style="list-style-type: none"> • 20" x 30" Laminate worksurface with curved front only • Ships fully assembled, packaged 1 lectern per carton • 28-3/4" to 42-3/4" height range • When chrome is selected the lower frame will be chrome and the upper column assembly will be starlight silver • Lectern is always on casters • Includes steel modesty panel 	RUX21E	<input type="checkbox"/> <input type="checkbox"/> <input type="checkbox"/> <input type="checkbox"/>	<input type="checkbox"/> <input type="checkbox"/>	<input type="checkbox"/> <input type="checkbox"/>	<input type="checkbox"/> <input type="checkbox"/>	<input type="checkbox"/>	<input type="checkbox"/> <input type="checkbox"/> <input type="checkbox"/> <input type="checkbox"/>		<input type="checkbox"/> <input type="checkbox"/>	68.00#	\$ 1459	\$ 19	

A B C D E F G H I

HOW TO ORDER

- Indicate the following information on order form:
1. Quantity of each item.
 2. Model number, including options. See "How To Build a Model Number".
 3. Any special service required.

Note:

- The indicates that a choice is required.
- The absence of the indicates that no choice is required.
- Alpha-numeric characters in place of indicate that no other alternatives are available.

HOW TO BUILD A MODEL NUMBER

- A** Select basic model.
- B** Select storage/accessories.
- NB** - No book storage
 - BH** - Bag hooks; add \$11
 - BR** - Book basket; add \$72
 - CL** - Swiveling cup holder - left side; add \$64
 - CR** - Swiveling cup holder - right side; add \$64
 - BHCL** - Book bag hook-right side & cup holder-left side; add \$70
 - BHCR** - Book bag hook-left side & cup holder-right side; add \$70
 - BRCL** - Book basket & cup holder - left side; add \$136
 - BRCR** - Book basket & cup holder - right side; add \$136
- C** Select base option.
- CHC** - Hard floor casters
 - CCC** - Carpet casters

- D** Select top laminate surface. Refer to the **Product Color Options** page in this price list.
- E** Select edge color. Refer to the **Product Color Options** page in this price list.
- F** Select base color. Refer to the **Product Color Options** page in this price list.
- G** Select book basket color. Refer to the **Product Color Options** page in this price list. When Book basket/rack & cup holder (BRCL or BRRCR) is selected the cup holder is always starlight silver metallic.
- H** Select felt modesty panel color. Refer to the **Product Color Options** page in this price list.
- I** Select steel modesty panel color. Refer to the **Product Color Options** page in this price list.

FINISH INFORMATION

Additional Laminate Offering

KI offers laminates beyond those offered in the standard offering. Laminates that are currently available in the program can be viewed in KI product specification tools. Requests to add laminates to the program can be submitted via the product modification request process. Please note, requests to add laminates to the program must include the laminate manufacturer's name, color/pattern number, and finish code. Edge options are limited to standard edge colors. If a matching edge is required, this will need to be requested through the product modification request process and may be subject to additional costs. Due to varying manufacturing processes and quality issues with some laminates, some requests may be denied. Extended lead times and minimum order quantities may apply on orders containing special laminates. Contact the product modification team for questions or additional information regarding special laminates and pricing.

SPECIAL SERVICES

Special Carton Marking
With specially marked information N/C

Shipping
Ships assembled, FOB Bonduel, WI 54107, freight prepaid. Freight class 125.

Specifications and prices are subject to change without prior notice.



Ruckus® Cantilever Desk (Delivered Pricing)

Desk

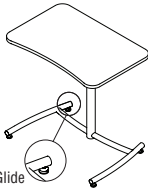
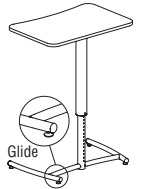

Ruckus® Cantilever Desk (Delivered Pricing)

Desk

MODEL	Features	MODEL NUMBER							Approx. Packaged Weight	Delivered Pricing	Laminate Grade 2 add to list price
		Basic Model	Storage Accessories	Base	Top Color	Edge Color	Base Color	Book Basket Color			
 RU420	Fixed Height - Glide Base 29" High • Laminate curved front only • 20" x 30" worksurface • Ships fully assembled, packaged 1 desk per carton	RU4201	<input type="checkbox"/>	<input type="checkbox"/>	<input type="checkbox"/>	<input type="checkbox"/>	<input type="checkbox"/>	<input type="checkbox"/>	39.0#	\$ 556	\$ 19
 RUD20	Set Screw Adjustable - Glide Base Set Screw Height Adj. • Facilities staff adjusted (tool required) • Laminate curved front only • 20" x 30" worksurface • Ships fully assembled, packaged 1 desk per carton • 27-1/4" - 41-1/2" height range (1" increments) • When chrome is selected the lower frame will be chrome and the upper column assembly will be starlight silver	RUD20A	<input type="checkbox"/>	<input type="checkbox"/>	<input type="checkbox"/>	<input type="checkbox"/>	<input type="checkbox"/>	<input type="checkbox"/>	42.0#	\$ 703	\$ 19
 RUY20	Pneumatic Adjustable - Glide Base Pneumatic Height Adj. • User adjusted • Laminate curved front only • 20" x 30" worksurface • Ships fully assembled, packaged 1 desk per carton • 27-1/4" - 41-1/2" height range • When chrome is selected the lower frame will be chrome and the upper column assembly will be starlight silver	RUY20E	<input type="checkbox"/>	<input type="checkbox"/>	<input type="checkbox"/>	<input type="checkbox"/>	<input type="checkbox"/>	<input type="checkbox"/>	42.0#	\$ 882	\$ 19
			A	B	C	D	E	F			

HOW TO ORDER

- Indicate the following information on order form:
- Quantity of each item.
 - Model number, including options. See "How To Build a Model Number".
 - Any special service required.

Note: • The indicates that a choice is required.

- The absence of the indicates that no choice is required.
- Alpha-numeric characters in place of indicate that no other alternatives are available.

HOW TO BUILD A MODEL NUMBER

A Select basic model.

B Select storage/accessories.

NB - No book storage

BH - Book bag hook; add \$11

BR - Book basket; add \$72

CL - Swiveling cup holder - left side;

add \$64

CR - Swiveling cup holder - right side;

add \$64

BHCL - Book bag hook-right side & cup

holder-left side; add \$70

BHCR - Book bag hook-left side & cup

holder-right side; add \$70

BRCL - Book basket & cup holder - left

side; add \$136

BRCR - Book basket & cup holder - right

side; add \$136

C Select base option.

GFT - Felt glides

GPL - Nylon plastic glides

GSL - Steel glides

D Select top laminate surface.

Refer to the **Product Color Options** page in this price list.

E Select edge color.

Refer to the **Product Color Options** page in this price list.

F Select base color.

Refer to the **Product Color Options** page in this price list.

G Select book basket color.

Refer to the **Product Color Options** page in this price list.

When Book basket/rack & cup holder (BRCL or BRCR) is selected the cup holder is always starlight silver metallic.

FINISH INFORMATION

Additional Laminate Offering

KI offers laminates beyond those offered in the standard offering. Laminates that are currently available in the program can be viewed in KI product specification tools. Requests to add laminates to the program can be submitted via the product modification request process. Please note, requests to add laminates to the program must include the laminate manufacturer's name, color/pattern number, and finish code. Edge options are limited to standard edge colors. If a matching edge is required, this will need to be requested through the product modification request process and may be subject to additional costs. Due to varying manufacturing processes and quality issues with some laminates, some requests may be denied. Extended lead times and minimum order quantities may apply on orders containing special laminates. Contact the product modification team for questions or additional information regarding special laminates and pricing.

SPECIAL SERVICES

Special Carton Marking

With specially marked information N/C

Shipping

Ships assembled, FOB Bondue1, WI 54107, freight prepaid. Freight class 125.

Specifications and prices are subject to change without prior notice.



Ruckus® Cantilever Desk (Delivered Pricing)

Desk

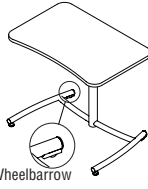

Ruckus® Cantilever Desk (Delivered Pricing)

Desk

MODEL	Features	MODEL NUMBER							Approx. Packaged Weight	Delivered Pricing	Laminate Grade 2 add to list price	
		Basic Model	Storage Accessories	Base	Top Color	Edge Color	Base Color	Book Basket Color				
 RU520	Fixed Height - Rolling Base • Laminate curved front only • 20" x 30" worksurface • Ships fully assembled, packaged 1 desk per carton	29" High	RU5201	<input type="checkbox"/>	<input type="checkbox"/>	<input type="checkbox"/>	<input type="checkbox"/>	<input type="checkbox"/>	<input type="checkbox"/>	39.0#	\$ 598	\$ 19
 RUE20	Set Screw Adjustable - Rolling Base • Facilities staff adjusted (tool required) • Laminate curved front only • 20" x 30" worksurface • Ships fully assembled, packaged 1 desk per carton • 27-1/4" - 41-1/2" height range (1" increments) • When chrome is selected the lower frame will be chrome and the upper column assembly will be starlight silver	Set Screw Height Adj	RUE20A	<input type="checkbox"/>	<input type="checkbox"/>	<input type="checkbox"/>	<input type="checkbox"/>	<input type="checkbox"/>	<input type="checkbox"/>	42.0#	\$ 734	\$ 19
 RUZ20	Pneumatic Adjustable - Rolling Base • User adjusted • Laminate curved front only • 20" x 30" worksurface • Ships fully assembled, packaged 1 desk per carton • 27-1/4" - 41-1/2" height range • When chrome is selected the lower frame will be chrome and the upper column assembly will be starlight silver	Pneumatic Height Adj.	RUZ20E	<input type="checkbox"/>	<input type="checkbox"/>	<input type="checkbox"/>	<input type="checkbox"/>	<input type="checkbox"/>	<input type="checkbox"/>	42.0#	\$ 908	\$ 19

A B C D E F G

HOW TO ORDER

- Indicate the following information on order form:
- Quantity of each item.
 - Model number, including options. See "How To Build a Model Number".
 - Any special service required.

- Note:
- The indicates that a choice is required.
 - The absence of the indicates that no choice is required.
 - Alpha-numeric characters in place of indicate that no other alternatives are available.

HOW TO BUILD A MODEL NUMBER

- A** Select basic model.
- B** Select storage/accessories.
- NB** - No book storage
 - BH** - Book bag hook; add \$11
 - BR** - Book basket; add \$72
 - CL** - Swiveling cup holder - left side; add \$64
 - CR** - Swiveling cup holder - right side; add \$64
 - BHCL** - Book bag hook-right side & cup holder-left side; add \$70
 - BHCR** - Book bag hook-left side & cup holder-right side; add \$70
 - BRCL** - Book basket & cup holder - left side; add \$136
 - BRCR** - Book basket & cup holder - right side; add \$136
- C** Select base option.
- RFT** - Wheelbarrow (rolling front, felt solo glides back)
 - RPL** - Wheelbarrow (roller front, plastic

- glides back)
 - RSL** - Wheelbarrow (rolling front, steel glides back)
- D** Select top laminate surface. Refer to the **Product Color Options** page in this price list.
- E** Select edge color. Refer to the **Product Color Options** page in this price list.
- F** Select base color. Refer to the **Product Color Options** page in this price list.
- G** Select book basket color. Refer to the **Product Color Options** page in this price list. When Book basket/rack & cup holder (BRCL or BRRCR) is selected the cup holder is always starlight silver metallic.

FINISH INFORMATION

Additional Laminate Offering
 KI offers laminates beyond those offered in the standard offering. Laminates that are currently available in the program can be viewed in KI product specification tools. Requests to add laminates to the program can be submitted via the product modification request process. Please note, requests to add laminates to the program must include the laminate manufacturer's name, color/pattern number, and finish code. Edge options are limited to standard edge colors. If a matching edge is required, this will need to be requested through the product modification request process and may be subject to additional costs. Due to varying manufacturing processes and quality issues with some laminates, some requests may be denied. Extended lead times and minimum order quantities may apply on orders containing special laminates. Contact the product modification team for questions or additional information regarding special laminates and pricing.

SPECIAL SERVICES

Special Carton Marking

With specially marked information N/C

Shipping
 Ships assembled, FOB Bondue, WI 54107, freight prepaid. Freight class 125.

Specifications and prices are subject to change without prior notice.

Ruckus® Cantilever Desk (Delivered Pricing)

ADA Desk



Ruckus® Cantilever Desk (Delivered Pricing)

ADA Desk

MODEL	Features	MODEL NUMBER							Approx. Packaged Weight	Delivered Pricing	Laminate Grade 2 add to list price
		Basic Model	Storage Accessories	Base	Top Color	Edge Color	Base Color	Book Basket Color			
ADA Set Screw Adjustable Desk - Rolling Base	Set Screw Adjustable - Rolling Base	RUE50A	<input type="checkbox"/> <input type="checkbox"/> <input type="checkbox"/> <input type="checkbox"/>	<input type="checkbox"/> <input type="checkbox"/>	<input type="checkbox"/> <input type="checkbox"/>	<input type="checkbox"/> <input type="checkbox"/>	<input type="checkbox"/> <input type="checkbox"/>	<input type="checkbox"/> <input type="checkbox"/>	64.0#	\$ 865	\$ 19
	<ul style="list-style-type: none"> Facilities staff adjusted (tool required) Laminate curved front only 25" x 36" laminate worksurface Ships fully assembled, packaged 1 desk per carton 27-1/4" - 31-1/4" height range (1" increments) When chrome is selected the lower frame will be chrome and the upper column assembly will be starlight silver 										
		A	B	C	D	E	F	G			



RUE50

HOW TO ORDER

- Indicate the following information on order form:
- Quantity of each item.
 - Model number, including options. See "How To Build a Model Number".
 - Any special service required.

Note:

- The indicates that a choice is required.
- The absence of the indicates that no choice is required.
- Alpha-numeric characters in place of indicate that no other alternatives are available.

HOW TO BUILD A MODEL NUMBER

- A** Select basic model.
 - RSL** - Wheelbarrow (rolling front, steel glides back)
- B** Select storage/accessories.
 - NB** - No book storage
 - BH** - Book bag hook; add \$11
 - BR** - Book basket; add \$72
 - CL** - Swiveling cup holder - left side; add \$64
 - CR** - Swiveling cup holder - right side; add \$64
 - BHCL** - Book bag hook-right side & cup holder-left side; add \$70
 - BHCR** - Book bag hook-left side & cup holder-right side; add \$70
 - BRCL** - Book basket & cup holder - left side; add \$136
 - BRCR** - Book basket & cup holder - right side; add \$136
- C** Select base option.
 - RFT** - Wheelbarrow (rolling front, felt solo glides back)
 - RPL** - Wheelbarrow (roller front, plastic glides back)
- D** Select top laminate surface. Refer to the **Product Color Options** page in this price list.
- E** Select edge color. Refer to the **Product Color Options** page in this price list.
- F** Select base color. Refer to the **Product Color Options** page in this price list.
- G** Select book basket color. Refer to the **Product Color Options** page in this price list. When Book basket/rack & cup holder (BRCL or BRRCR) is selected the cup holder is always starlight silver metallic.

FINISH INFORMATION

Additional Laminate Offering
 KI offers laminates beyond those offered in the standard offering. Laminates that are currently available in the program can be viewed in KI product specification tools. Requests to add laminates to the program can be submitted via the product modification request process. Please note, requests to add laminates to the program must include the laminate manufacturer's name, color/pattern number, and finish code. Edge options are limited to standard edge colors. If a matching edge is required, this will need to be requested through the product modification request process and may be subject to additional costs. Due to varying manufacturing processes and quality issues with some laminates, some requests may be denied. Extended lead times and minimum order quantities may apply on orders containing special laminates. Contact the product modification team for questions or additional information regarding special laminates and pricing.

SPECIAL SERVICES

Special Carton Marking
 With specially marked information N/C

Shipping
 Ships assembled, FOB Bondue1, WI 54107, freight prepaid. Freight class 150.

Specifications and prices are subject to change without prior notice.

Ruckus® Stacking Desk (Delivered Pricing)

Rounded Corner



Ruckus® Stacking Desk (Delivered Pricing)

Rounded Corner

MODEL	A x B	MODEL NUMBER					Approx. Packaged Weight	Delivered Pricing	Chrome Upcharge add to list price
		Basic Model/Edge Style	Edge Color	Surface Finish	Base Finish	Base Option			
<p>Fixed Height Rectangular Rounded Corners, 29\"H</p> <ul style="list-style-type: none"> Stack up to 4 high Unitized steel frame Ship fully assembled Casters and glides are interchangeable 20x36 and 24x36 desk are ADA compliant 	20 x 30"	RKEEA2030-73P	<input type="checkbox"/>	<input type="checkbox"/>	<input type="checkbox"/>	40.5#	\$ 519	\$ 35	
	20 x 36"	RKEEA2036-73P	<input type="checkbox"/>	<input type="checkbox"/>	<input type="checkbox"/>	43.0#	560	37	
	24 x 30"	RKEEA2430-73P	<input type="checkbox"/>	<input type="checkbox"/>	<input type="checkbox"/>	43.0#	532	37	
	24 x 36"	RKEEA2436-73P	<input type="checkbox"/>	<input type="checkbox"/>	<input type="checkbox"/>	45.5#	566	39	
<p>Adjustable Height Rectangular Rounded Corners, 21-32\"H</p> <ul style="list-style-type: none"> Stack up to 4 high Unitized steel frame Ship fully assembled Casters and glides are interchangeable Legs adjust in 1" increments Legs are factory pre-set at 29\"H 20x36 and 24x36 desk are ADA compliant 	20 x 30"	RKEEA2030-73P	<input type="checkbox"/>	<input type="checkbox"/>	<input type="checkbox"/>	42.0#	\$ 588	\$ 46	
	20 x 36"	RKEEA2036-73P	<input type="checkbox"/>	<input type="checkbox"/>	<input type="checkbox"/>	44.5#	640	48	
	24 x 30"	RKEEA2430-73P	<input type="checkbox"/>	<input type="checkbox"/>	<input type="checkbox"/>	44.5#	601	48	
	24 x 36"	RKEEA2436-73P	<input type="checkbox"/>	<input type="checkbox"/>	<input type="checkbox"/>	47.0#	643	50	

A B C D E

HOW TO ORDER

- Indicate the following information on order form:
- Quantity of each item.
 - Model number, including options. See "How To Build a Model Number".
 - Any special service required.

Note: • The indicates that a choice is required.

- The absence of the indicates that no choice is required.
- Alpha-numeric characters in place of indicate that no other alternatives are available.

HOW TO BUILD A MODEL NUMBER

- A** Select basic model/edge style.
74P - 1-1/4" laminate top w/74P edge band
- B** Select edge color.
 Refer to the **Product Color Options** page in this price list.
- C** Select surface finish.
 Refer to the **Product Color Options** page in this price list.
- D** Select base finish.
 Refer to the **Product Color Options** page in this price list.
- E** Select base option.

BCF	- Casters/felt glides
BCN	- Casters/nylon glides
GFT	- Felt glides
GNY	- Nylon glides
CCC	- Casters

SPECIAL SERVICES

Special Carton Marking

With specially marked information N/C

Shipping

Ships **assembled, FOB Bonduei, WI 54107, freight prepaid.** Freight class 125.

Specifications and prices are subject to change without prior notice.

Ruckus® Stacking Desk (Delivered Pricing)

Square Corner



Ruckus® Stacking Desk (Delivered Pricing)

Square Corner

MODEL	A x B	MODEL NUMBER					Approx. Packaged Weight	Delivered Pricing	Chrome Upcharge add to list price
		Basic Model/Edge Style	Edge Color	Surface Finish	Base Finish	Base Option			
<p>Fixed Height Rectangular Square Corners, 29\"H</p> <ul style="list-style-type: none"> Stack up to 4 high Unitized steel frame Ship fully assembled Casters and glides are interchangeable 20x36 and 24x36 desk are ADA compliant 	20 x 30"	RZEEA2030-73P	<input type="checkbox"/>	<input type="checkbox"/>	40.5#	\$ 519	\$ 35		
	20 x 36"	RZEEA2036-73P	<input type="checkbox"/>	<input type="checkbox"/>	43.0#	560	37		
	24 x 30"	RZEEA2430-73P	<input type="checkbox"/>	<input type="checkbox"/>	43.0#	532	37		
	24 x 36"	RZEEA2436-73P	<input type="checkbox"/>	<input type="checkbox"/>	45.0#	566	39		
RZEAA									
<p>Adjustable Height Rectangular Square Corners, 21-32\"H</p> <ul style="list-style-type: none"> Stack up to 4 high Unitized steel frame Ship fully assembled Casters and glides are interchangeable Legs adjust in 1" increments Legs are factory pre-set at 29\"H 20x36 and 24x36 desk are ADA compliant 	20 x 30"	RZEEA2030-73P	<input type="checkbox"/>	<input type="checkbox"/>	42.0#	\$ 588	\$ 46		
	20 x 36"	RZEEA2036-73P	<input type="checkbox"/>	<input type="checkbox"/>	44.5#	640	48		
	24 x 30"	RZEEA2430-73P	<input type="checkbox"/>	<input type="checkbox"/>	44.5#	601	48		
	24 x 36"	RZEEA2436-73P	<input type="checkbox"/>	<input type="checkbox"/>	47.0#	643	50		
RZEEA									

A

B

C

D

E

HOW TO ORDER

- Indicate the following information on order form:
- Quantity of each item.
 - Model number, including options. See "How To Build a Model Number".
 - Any special service required.

Note:

- The indicates that a choice is required.
- The absence of the indicates that no choice is required.
- Alpha-numeric characters in place of indicate that no other alternatives are available.

HOW TO BUILD A MODEL NUMBER

- A** Select basic model/edge style.

74P	- 1-1/4" laminate top w/74P edge band
------------	---------------------------------------
- B** Select edge color.
 Refer to the **Product Color Options** page in this price list.
- C** Select surface finish.
 Refer to the **Product Color Options** page in this price list.
- D** Select base finish.
 Refer to the **Product Color Options** page in this price list.
- E** Select base option.

BCF	- Casters/felt glides
BCN	- Casters/nylon glides
GFT	- Felt glides
GNY	- Nylon glides
CCC	- Casters

SPECIAL SERVICES

Special Carton Marking

With specially marked information N/C

Shipping

Ships assembled, FOB Bondue1, WI 54107, freight prepaid. Freight class 125.

Specifications and prices are subject to change without prior notice.

Ruckus® Post-Leg Desk (Delivered Pricing)

3/4" Top - 73P Edge



Ruckus® Post-Leg Desk (Delivered Pricing)

3/4" Top - 73P Edge

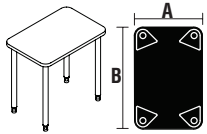
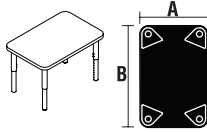
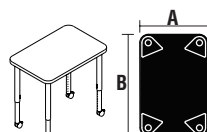
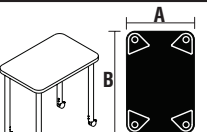
MODEL	A x B	MODEL NUMBER								Approx. Packaged Weight	Delivered Pricing	Chrome Upcharge add to list price	Laminate Grade 2 add to list price	
		Basic Model/Edge Style	Edge Color	Surface Finish	Base Finish	Base Option	Under Table Storage	Book Basket Color	Book Box Color					
 <p>Fixed Height Rectangular Desk, 28-1/2" H</p> <ul style="list-style-type: none"> • Casters and glides are interchangeable • Ruckus post-leg desks require assembly • All corners of surface are rounded • Specify casters/glides to wheelbarrow 	20 x 30"	RDEEA2030-73P	<input type="checkbox"/>	<input type="checkbox"/>	<input type="checkbox"/>	<input type="checkbox"/>	42.8#	\$ 402	\$ 68	\$ 19				
	20 x 36"	RDEEA2036-73P	<input type="checkbox"/>	<input type="checkbox"/>	<input type="checkbox"/>	<input type="checkbox"/>	47.0#	428	68	19				
	24 x 36"	RDEEA2436-73P	<input type="checkbox"/>	<input type="checkbox"/>	<input type="checkbox"/>	<input type="checkbox"/>	52.0#	440	68	19				
RDEEA														
 <p>Floor Height Adjustable Rectangular Desk, 11-1/2 to 18-1/2" H</p> <ul style="list-style-type: none"> • Ruckus post-leg desks require assembly • All corners of surface are rounded • Legs adjust with screws in 1" increments • Legs are factory pre-set at 18-1/2"H • Base only available in glides 	20 x 30"	RDEHA2030-73P	<input type="checkbox"/>	<input type="checkbox"/>	<input type="checkbox"/>	<input type="checkbox"/>	40.3#	\$ 466	\$ 71	\$ 19				
	20 x 36"	RDEHA2036-73P	<input type="checkbox"/>	<input type="checkbox"/>	<input type="checkbox"/>	<input type="checkbox"/>	44.5#	493	71	19				
	24 x 36"	RDEHA2436-73P	<input type="checkbox"/>	<input type="checkbox"/>	<input type="checkbox"/>	<input type="checkbox"/>	49.5#	502	71	19				
RDEHA														
 <p>Sit Height Adjustable Rectangular Desk, 19-1/2 to 32-1/2" H</p> <ul style="list-style-type: none"> • Casters and glides are interchangeable • Ruckus post-leg desks require assembly • All corners of surface are rounded • Specify casters/glides to wheelbarrow • Legs adjust with screws in 1" increments • Legs are factory pre-set at 28-1/2"H • 20 x 37" desk is ADA compliant 	20 x 30"	RDEEA2030-73P	<input type="checkbox"/>	<input type="checkbox"/>	<input type="checkbox"/>	<input type="checkbox"/>	44.8#	\$ 452	\$ 74	\$ 19				
	20 x 36"	RDEEA2036-73P	<input type="checkbox"/>	<input type="checkbox"/>	<input type="checkbox"/>	<input type="checkbox"/>	49.0#	478	74	19				
	24 x 36"	RDEEA2436-73P	<input type="checkbox"/>	<input type="checkbox"/>	<input type="checkbox"/>	<input type="checkbox"/>	54.0#	486	74	19				
	20 x 37"	RDEEA2037ADA-73P	<input type="checkbox"/>	<input type="checkbox"/>	<input type="checkbox"/>	<input type="checkbox"/>	49.7#	543	74	19				
RDEEA														
 <p>Sit-Stand Height Adjustable Rectangular Desk, 28-1/2 to 41-1/2" H</p> <ul style="list-style-type: none"> • Casters and glides are interchangeable • Ruckus post-leg desks require assembly • All corners of surface are rounded • Specify casters/glides to wheelbarrow • Legs adjust with screws in 1" increments • Legs are factory pre-set at 28-1/2"H • 20 x 37" desk is ADA compliant 	20 x 30"	RDEFA2030-73P	<input type="checkbox"/>	<input type="checkbox"/>	<input type="checkbox"/>	<input type="checkbox"/>	48.8#	\$ 488	\$ 85	\$ 19				
	20 x 36"	RDEFA2036-73P	<input type="checkbox"/>	<input type="checkbox"/>	<input type="checkbox"/>	<input type="checkbox"/>	53.0#	505	85	19				
	24 x 36"	RDEFA2436-73P	<input type="checkbox"/>	<input type="checkbox"/>	<input type="checkbox"/>	<input type="checkbox"/>	58.0#	513	85	19				
	20 x 37"	RDEFA2037ADA-73P	<input type="checkbox"/>	<input type="checkbox"/>	<input type="checkbox"/>	<input type="checkbox"/>	53.7#	570	85	19				
RDEFA														

A **B** **C** **D** **E** **F** **G** **H**

HOW TO ORDER

- Indicate the following information on order form:
- Quantity of each item.
 - Model number, including options. See "How To Build a Model Number".
 - Any special service required.

Note: • The indicates that a choice is required.
 • The absence of the indicates that no choice is required.
 • Alpha-numeric characters in place of indicate that no other alternatives are available.

HOW TO BUILD A MODEL NUMBER

- A** Select basic model/edge style.
73P - 3/4" laminate top w/73P edge band
- B** Select edge color.
 Refer to the **Product Color Options** page in this price list.
- C** Select surface finish.
 Refer to the **Product Color Options** page in this price list.
- D** Select base finish.
 Refer to the **Product Color Options** page in this price list.
- E** Select base option.
BCF - Casters/felt glides
BCN - Casters/nylon glides
GFT - Felt glides
GNY - Nylon glides
CCC - Casters
 Base options for Floor Height Adjustable are

ONLY Felt glides - GFT and Nylon glides - GNY

- F** Select under table storage.
NB - No book storage
BBS - Poly book box, small; add \$34
BBL - Poly book box, large; add \$39
BR - Book basket; add \$50
RT - Removable storage tote; add \$51
SBBS - Steel book box, small; add \$73
SBBL - Steel book box, large; add \$84
 BBL & SBBL options are not available on the 20x30" desk sizes.
- G** Select book basket color.
 Refer to the **Product Color Options** page in this price list.
 Only if book basket (BR) storage is selected.
- H** Select steel book box color.
 Refer to the **Product Color Options** page in this price list.
 Only if steel book box (SBBS or SBBL) storage is selected.

FINISH INFORMATION

Additional Laminate Offering

KI offers laminates beyond those offered in the standard offering. Laminates that are currently available in the program can be viewed in KI product specification tools. Requests to add laminates to the program can be submitted via the product modification request process. Please note, requests to add laminates to the program must include the laminate manufacturer's name, color/pattern number, and finish code. Edge options are limited to standard edge colors. If a matching edge is required, this will need to be requested through the product modification request process and may be subject to additional costs. Due to varying manufacturing processes and quality issues with some laminates, some requests may be denied. Extended lead times and minimum order quantities may apply on orders containing special laminates. Contact the product modification team for questions or additional information regarding special laminates and pricing.

SPECIAL SERVICES

Special Carton Marking

With specially marked information N/C

Shipping

Ships **knocked down, FOB Bonduel, WI 54107, freight prepaid.** Freight class 70.

Specifications and prices are subject to change without prior notice.

Ruckus® Post-Leg Desk (Delivered Pricing)

3/4" Top - 73P Edge



Ruckus® Post-Leg Desk (Delivered Pricing)

3/4" Top - 73P Edge

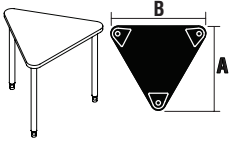
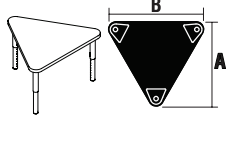
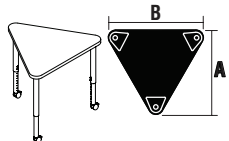
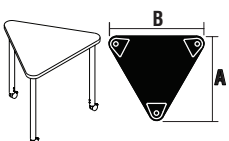
MODEL	Features	A x B	MODEL NUMBER								Approx. Packaged Weight	Delivered Pricing	Chrome Upcharge add to list price	Laminate Grade 2 add to list price
			Basic Model/Edge Style	Edge Color	Surface Finish	Base Finish	Base Option	Under Table Storage	Book Basket Color	Book Box Color				
 RDEAK	Fixed Height E-Triangle Desk, 28-1/2" H • Casters and glides are interchangeable • Ruckus post-leg desks require assembly • All corners of surface are rounded • Specify casters/glides to wheelbarrow • 6 Desks combine to form an hexagon	Small 28 x 32"	RDEAK32-73P	<input type="checkbox"/>	<input type="checkbox"/>	<input type="checkbox"/>	<input type="checkbox"/>	29.0#	\$ 372	\$ 51	\$ 19			
		Large 33 x 37"	RDEAK37-73P	<input type="checkbox"/>	<input type="checkbox"/>	<input type="checkbox"/>	<input type="checkbox"/>	33.0#	440	51	27			
 RDEHK	Floor Height Adjustable E-Triangle Desk, 11-1/2" to 18-1/2" H • Ruckus post-leg desks require assembly • All corners of surface are rounded • Legs adjust with screws in 1" increments • Legs are factory pre-set at 18-1/2"H • 6 Desks combine to form an hexagon • Base only available in glides	Small 28 x 32"	RDEHK32-73P	<input type="checkbox"/>	<input type="checkbox"/>	<input type="checkbox"/>	<input type="checkbox"/>	27.2#	\$ 424	\$ 71	\$ 19			
		Large 33 x 37"	RDEHK37-73P	<input type="checkbox"/>	<input type="checkbox"/>	<input type="checkbox"/>	<input type="checkbox"/>	31.1#	493	71	27			
 RDEEK	Sit Height Adjustable E-Triangle Desk, 19-1/2 to 32-1/2" H • Casters and glides are interchangeable • Ruckus post-leg desks require assembly • All corners of surface are rounded • Specify casters/glides to wheelbarrow • Legs adjust with screws in 1" increments • Legs are factory pre-set at 28-1/2"H • 6 Desks combine to form an hexagon	Small 28 x 32"	RDEEK32-73P	<input type="checkbox"/>	<input type="checkbox"/>	<input type="checkbox"/>	<input type="checkbox"/>	30.5#	\$ 410	\$ 56	\$ 19			
		Large 33 x 37"	RDEEK37-73P	<input type="checkbox"/>	<input type="checkbox"/>	<input type="checkbox"/>	<input type="checkbox"/>	34.5#	477	56	27			
 RDEFK	Sit-Stand Height Adjustable E-Triangle Desk, 28-1/2 to 41-1/2" H • Casters and glides are interchangeable • Ruckus post-leg desks require assembly • All corners of surface are rounded • Specify casters/glides to wheelbarrow • Legs adjust with screws in 1" increments • Legs are factory pre-set at 28-1/2"H • 6 Desks combine to form an hexagon	Small 28 x 32"	RDEFK32-73P	<input type="checkbox"/>	<input type="checkbox"/>	<input type="checkbox"/>	<input type="checkbox"/>	33.5#	\$ 442	\$ 65	\$ 19			
		Large 33 x 37"	RDEFK37-73P	<input type="checkbox"/>	<input type="checkbox"/>	<input type="checkbox"/>	<input type="checkbox"/>	37.5#	512	65	27			

A **B** **C** **D** **E** **F** **G** **H**

HOW TO ORDER

- Indicate the following information on order form:
- Quantity of each item.
 - Model number, including options. See "How To Build a Model Number".
 - Any special service required.

Note: • The indicates that a choice is required.
 • The absence of the indicates that no choice is required.
 • Alpha-numeric characters in place of indicate that no other alternatives are available.

HOW TO BUILD A MODEL NUMBER

- A** Select basic model/edge style.
73P - 3/4" laminate top w/73P edge band
- B** Select edge color.
 Refer to the **Product Color Options** page in this price list.
- C** Select surface finish.
 Refer to the **Product Color Options** page in this price list.
- D** Select base finish.
 Refer to the **Product Color Options** page in this price list.
- E** Select base option.
CCC - Casters
BCF - Casters/felt glides
BCN - Casters/nylon glides
GFT - Felt glides
GNV - Nylon glides
 Base options for Floor Height Adjustable are

- ONLY Felt glides - GFT and Nylon glides - GNV
- F** Select under table storage.
NB - No book storage
BBS - Poly book box, small; add \$34
BBL - Poly book box, large; add \$39
BR - Book basket; add \$50
RT - Removable storage tote; add \$51
SBBS - Steel book box, small; add \$73
SBBL - Steel book box, large; add \$84
 BBL & SBBL options are not available on the small desk sizes.
- G** Select book basket color.
 Refer to the **Product Color Options** page in this price list.
 Only if book basket (BR) storage is selected.
- H** Select steel book box color.
 Refer to the **Product Color Options** page in this price list.
 Only if steel book box (SBBS or SBBL) storage is selected.

FINISH INFORMATION

Additional Laminate Offering
 KI offers laminates beyond those offered in the standard offering. Laminates that are currently available in the program can be viewed in KI product specification tools. Requests to add laminates to the program can be submitted via the product modification request process. Please note, requests to add laminates to the program must include the laminate manufacturer's name, color/pattern number, and finish code. Edge options are limited to standard edge colors. If a matching edge is required, this will need to be requested through the product modification request process and may be subject to additional costs. Due to varying manufacturing processes and quality issues with some laminates, some requests may be denied. Extended lead times and minimum order quantities may apply on orders containing special laminates. Contact the product modification team for questions or additional information regarding special laminates and pricing.

SPECIAL SERVICES

Special Carton Marking
 With specially marked information N/C

Shipping
 Ships **knocked down, FOB Bonduel, WI 54107, freight prepaid.** Freight class 70.

Specifications and prices are subject to change without prior notice.

Ruckus® Post-Leg Desk (Delivered Pricing)

3/4" Top - 73P Edge



Ruckus® Post-Leg Desk (Delivered Pricing)

3/4" Top - 73P Edge

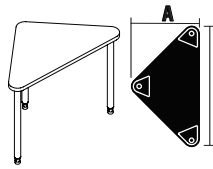
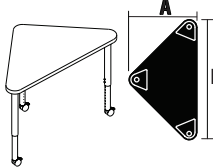
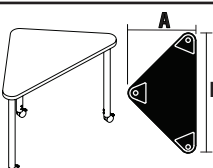
MODEL	Features	A x B	MODEL NUMBER								Approx. Packaged Weight	Delivered Pricing	Chrome Upcharge add to list price	Laminate Grade 2 add to list price	
			Basic Model/Edge Style	Edge Color	Surface Finish	Base Finish	Base Option	Under Table Storage	Book Basket Color	Book Box Color					
 Fixed Height R-Triangle Desk, 28-1/2" H • Casters and glides are interchangeable • Ruckus post-leg desks require assembly • All corners of surface are rounded • Specify casters/glides to wheelbarrow • 4 Desks combine to form a square	Small	22 x 39"	RDEAL39-73P	<input type="checkbox"/>	<input type="checkbox"/>	<input type="checkbox"/>	<input type="checkbox"/>	<input type="checkbox"/>	<input type="checkbox"/>	<input type="checkbox"/>	<input type="checkbox"/>	29.0#	\$ 372	\$ 51	\$ 19
	Large	26 x 47"	RDEAL47-73P	<input type="checkbox"/>	<input type="checkbox"/>	<input type="checkbox"/>	<input type="checkbox"/>	<input type="checkbox"/>	<input type="checkbox"/>	<input type="checkbox"/>	<input type="checkbox"/>	33.0#	383	51	27
RDEAL															
 Sit Height Adjustable R-Triangle Desk, 19-1/2 to 32-1/2" H • Casters and glides are interchangeable • Ruckus post-leg desks require assembly • All corners of surface are rounded • Specify casters/glides to wheelbarrow • Legs adjust with screws in 1" increments • Legs are factory pre-set at 28-1/2"H • 4 Desks combine to form a square	Small	22 x 39"	RDEEL39-73P	<input type="checkbox"/>	<input type="checkbox"/>	<input type="checkbox"/>	<input type="checkbox"/>	<input type="checkbox"/>	<input type="checkbox"/>	<input type="checkbox"/>	<input type="checkbox"/>	30.5#	\$ 410	\$ 56	\$ 19
	Large	26 x 47"	RDEEL47-73P	<input type="checkbox"/>	<input type="checkbox"/>	<input type="checkbox"/>	<input type="checkbox"/>	<input type="checkbox"/>	<input type="checkbox"/>	<input type="checkbox"/>	<input type="checkbox"/>	34.5#	421	56	27
RDEEL															
 Sit-Stand Height Adjustable R-Triangle Desk, 28-1/2 to 41-1/2" H • Casters and glides are interchangeable • Ruckus post-leg desks require assembly • All corners of surface are rounded • Specify casters/glides to wheelbarrow • Legs adjust with screws in 1" increments • Legs are factory pre-set at 28-1/2"H • 4 Desks combine to form a square	Small	22 x 39"	RDEFL39-73P	<input type="checkbox"/>	<input type="checkbox"/>	<input type="checkbox"/>	<input type="checkbox"/>	<input type="checkbox"/>	<input type="checkbox"/>	<input type="checkbox"/>	<input type="checkbox"/>	33.5#	\$ 442	\$ 65	\$ 19
	Large	26 x 47"	RDEFL47-73P	<input type="checkbox"/>	<input type="checkbox"/>	<input type="checkbox"/>	<input type="checkbox"/>	<input type="checkbox"/>	<input type="checkbox"/>	<input type="checkbox"/>	<input type="checkbox"/>	37.5#	454	65	27
RDEFL															

A **B** **C** **D** **E** **F** **G** **H**

HOW TO ORDER

- Indicate the following information on order form:
- Quantity of each item.
 - Model number, including options. See "How To Build a Model Number".
 - Any special service required.

Note: • The indicates that a choice is required.
 • The absence of the indicates that no choice is required.
 • Alpha-numeric characters in place of indicate that no other alternatives are available.

HOW TO BUILD A MODEL NUMBER

- A** Select basic model/edge style.
73P - 3/4" laminate top w/73P edge band
- B** Select edge color.
 Refer to the **Product Color Options** page in this price list.
- C** Select surface finish.
 Refer to the **Product Color Options** page in this price list.
- D** Select base finish.
 Refer to the **Product Color Options** page in this price list.
- E** Select base option.
BCF - Casters/felt glides
BCN - Casters/nylon glides
GFT - Felt glides
GNY - Nylon glides
CCC - Casters

- F** Select under table storage.
NB - No book storage
BBS - Poly book box, small; add \$34
BBL - Poly book box, large; add \$39
BR - Book basket; add \$50
RT - Removable storage tote; add \$51
SBBS - Steel book box, small; add \$73
SBBL - Steel book box, large; add \$84
 BBL & SBBL options are not available on the small desk sizes.
- G** Select book basket color.
 Refer to the **Product Color Options** page in this price list.
 Only if book basket (BR) storage is selected.
- H** Select steel book box color.
 Refer to the **Product Color Options** page in this price list.
 Only if steel book box (SBBS or SBBL) storage is selected.

FINISH INFORMATION

Additional Laminate Offering
 KI offers laminates beyond those offered in the standard offering. Laminates that are currently available in the program can be viewed in KI product specification tools. Requests to add laminates to the program can be submitted via the product modification request process. Please note, requests to add laminates to the program must include the laminate manufacturer's name, color/pattern number, and finish code. Edge options are limited to standard edge colors. If a matching edge is required, this will need to be requested through the product modification request process and may be subject to additional costs. Due to varying manufacturing processes and quality issues with some laminates, some requests may be denied. Extended lead times and minimum order quantities may apply on orders containing special laminates. Contact the product modification team for questions or additional information regarding special laminates and pricing.

SPECIAL SERVICES

Special Carton Marking
 With specially marked information N/C

Shipping
 Ships **knocked down, FOB Bonduel, WI 54107, freight prepaid**. Freight class 70.

Specifications and prices are subject to change without prior notice.

Ruckus® Post-Leg Desk (Delivered Pricing)

3/4" Top - 73P Edge



Ruckus® Post-Leg Desk (Delivered Pricing)

3/4" Top - 73P Edge

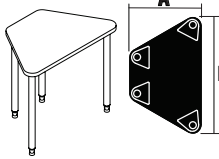
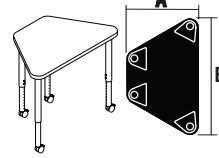
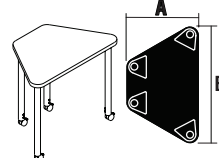
MODEL	Features	A x B	MODEL NUMBER								Approx. Packaged Weight	Delivered Pricing	Chrome Upcharge add to list price	Laminate Grade 2 add to list price	
			Basic Model/Edge Style	Edge Color	Surface Finish	Base Finish	Base Option	Under Table Storage	Book Basket Color	Book Box Color					
 RDEAM Fixed Height Trapezoid Desk, 28-1/2" H • Casters and glides are interchangeable • Ruckus post-leg desks require assembly • All corners of surface are rounded • Specify casters/glides to wheelbarrow • 6 Desks combine to form a hexagon	Small	21 x 34"	RDEAM34-73P	<input type="checkbox"/>	<input type="checkbox"/>	<input type="checkbox"/>	<input type="checkbox"/>	<input type="checkbox"/>	<input type="checkbox"/>	<input type="checkbox"/>	<input type="checkbox"/>	35.0#	\$ 414	\$ 68	\$ 19
	Large	24 x 37"	RDEAM37-73P	<input type="checkbox"/>	<input type="checkbox"/>	<input type="checkbox"/>	<input type="checkbox"/>	<input type="checkbox"/>	<input type="checkbox"/>	<input type="checkbox"/>	<input type="checkbox"/>	38.0#	449	68	19
 RDEEM Sit Height Adjustable Trapezoid Desk, 19-1/2 to 32-1/2" H • Casters and glides are interchangeable • Ruckus post-leg desks require assembly • All corners of surface are rounded • Specify casters/glides to wheelbarrow • Legs adjust with screws in 1" increments • Legs are factory pre-set at 28-1/2"H • 6 Desks combine to form a hexagon	Small	21 x 34"	RDEEM34-73P	<input type="checkbox"/>	<input type="checkbox"/>	<input type="checkbox"/>	<input type="checkbox"/>	<input type="checkbox"/>	<input type="checkbox"/>	<input type="checkbox"/>	<input type="checkbox"/>	37.0#	\$ 460	\$ 74	\$ 19
	Large	24 x 37"	RDEEM37-73P	<input type="checkbox"/>	<input type="checkbox"/>	<input type="checkbox"/>	<input type="checkbox"/>	<input type="checkbox"/>	<input type="checkbox"/>	<input type="checkbox"/>	<input type="checkbox"/>	40.0#	494	74	19
 RDEFM Sit-Stand Height Adjustable Trapezoid Desk, 28-1/2 to 41-1/2" H • Casters and glides are interchangeable • Ruckus post-leg desks require assembly • All corners of surface are rounded • Specify casters/glides to wheelbarrow • Legs adjust with screws in 1" increments • Legs are factory pre-set at 28-1/2"H • 6 Desks combine to form a hexagon	Small	21 x 34"	RDEFM34-73P	<input type="checkbox"/>	<input type="checkbox"/>	<input type="checkbox"/>	<input type="checkbox"/>	<input type="checkbox"/>	<input type="checkbox"/>	<input type="checkbox"/>	<input type="checkbox"/>	41.0#	\$ 494	\$ 85	\$ 19
	Large	24 x 37"	RDEFM37-73P	<input type="checkbox"/>	<input type="checkbox"/>	<input type="checkbox"/>	<input type="checkbox"/>	<input type="checkbox"/>	<input type="checkbox"/>	<input type="checkbox"/>	<input type="checkbox"/>	44.0#	531	85	19

A B C D E F G H

HOW TO ORDER

- Indicate the following information on order form:
- Quantity of each item.
 - Model number, including options. See "How To Build a Model Number".
 - Any special service required.

Note: • The indicates that a choice is required.
 • The absence of the indicates that no choice is required.
 • Alpha-numeric characters in place of indicate that no other alternatives are available.

HOW TO BUILD A MODEL NUMBER

- A** Select basic model/edge style.
73P - 3/4" laminate top w/73P edge band
- B** Select edge color.
 Refer to the **Product Color Options** page in this price list.
- C** Select surface finish.
 Refer to the **Product Color Options** page in this price list.
- D** Select base finish.
 Refer to the **Product Color Options** page in this price list.
- E** Select base option.
CCC - Casters
BCF - Casters/felt glides
BCN - Casters/nylon glides
GFT - Felt glides
GNV - Nylon glides

- F** Select under table storage.
NB - No book storage
BBS - Poly book box, small; add \$34
BBL - Poly book box, large; add \$39
BR - Book basket; add \$50
RT - Removable storage tote; add \$51
SBBS - Steel book box, small; add \$73
SBBL - Steel book box, large; add \$84
 BBL & SBBL options are not available on the small desk sizes.
- G** Select book basket color.
 Refer to the **Product Color Options** page in this price list.
 Only if book basket (BR) storage is selected.
- H** Select steel book box color.
 Refer to the **Product Color Options** page in this price list.
 Only if steel book box (SBBS or SBBL) storage is selected.

FINISH INFORMATION

Additional Laminate Offering

KI offers laminates beyond those offered in the standard offering. Laminates that are currently available in the program can be viewed in KI product specification tools. Requests to add laminates to the program can be submitted via the product modification request process. Please note, requests to add laminates to the program must include the laminate manufacturer's name, color/pattern number, and finish code. Edge options are limited to standard edge colors. If a matching edge is required, this will need to be requested through the product modification request process and may be subject to additional costs. Due to varying manufacturing processes and quality issues with some laminates, some requests may be denied. Extended lead times and minimum order quantities may apply on orders containing special laminates. Contact the product modification team for questions or additional information regarding special laminates and pricing.

SPECIAL SERVICES

Special Carton Marking

With specially marked information N/C

Shipping
 Ships **knocked down, FOB Bonduel, WI 54107, freight prepaid**. Freight class 70.

Specifications and prices are subject to change without prior notice.

Ruckus® Post-Leg Desk (Delivered Pricing)

3/4" Top - 73P Edge



Ruckus® Post-Leg Desk (Delivered Pricing)

3/4" Top - 73P Edge

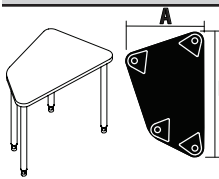
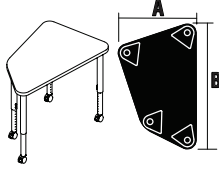
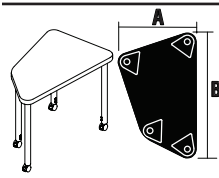
MODEL	Features	A x B	MODEL NUMBER								Approx. Packaged Weight	Delivered Pricing	Chrome Upcharge add to list price	Laminate Grade 2 add to list price
			Basic Model/Edge Style	Edge Color	Surface Finish	Base Finish	Base Option	Under Table Storage	Book Basket Color	Book Box Color				
 RDEAZ Fixed Height Oddquad Desk, 28-1/2" H • Casters and glides are interchangeable • Ruckus post-leg desks require assembly • All corners of surface are rounded • Specify casters/glides to wheelbarrow • 4 Desks combine to form a pin-wheel	Small	22 x 36"	RDEAZ36-73P	<input type="checkbox"/>	<input type="checkbox"/>	<input type="checkbox"/>	<input type="checkbox"/>	<input type="checkbox"/>	<input type="checkbox"/>	<input type="checkbox"/>	35.0#	\$ 435	\$ 68	\$ 19
	Large	24 x 39"	RDEAZ39-73P	<input type="checkbox"/>	<input type="checkbox"/>	<input type="checkbox"/>	<input type="checkbox"/>	<input type="checkbox"/>	<input type="checkbox"/>	<input type="checkbox"/>	38.0#	452	68	19
 RDEEZ Sit Height Adjustable Oddquad Desk, 19-1/2 to 32-1/2" H • Casters and glides are interchangeable • Ruckus post-leg desks require assembly • All corners of surface are rounded • Specify casters/glides to wheelbarrow • Legs adjust with screws in 1" increments • Legs are factory pre-set at 28-1/2"H • 4 Desks combine to form a pin-wheel	Small	22 x 36"	RDEEZ36-73P	<input type="checkbox"/>	<input type="checkbox"/>	<input type="checkbox"/>	<input type="checkbox"/>	<input type="checkbox"/>	<input type="checkbox"/>	<input type="checkbox"/>	37.0#	\$ 480	\$ 74	\$ 19
	Large	24 x 39"	RDEEZ39-73P	<input type="checkbox"/>	<input type="checkbox"/>	<input type="checkbox"/>	<input type="checkbox"/>	<input type="checkbox"/>	<input type="checkbox"/>	<input type="checkbox"/>	40.0#	501	74	19
 RDEFZ Sit-Stand Height Adjustable Oddquad Desk, 28-1/2 to 41-1/2" H • Casters and glides are interchangeable • Ruckus post-leg desks require assembly • All corners of surface are rounded • Specify casters/glides to wheelbarrow • Legs adjust with screws in 1" increments • Legs are factory pre-set at 28-1/2"H • 4 Desks combine to form a pin-wheel	Small	22 x 36"	RDEFZ36-73P	<input type="checkbox"/>	<input type="checkbox"/>	<input type="checkbox"/>	<input type="checkbox"/>	<input type="checkbox"/>	<input type="checkbox"/>	<input type="checkbox"/>	41.0#	\$ 515	\$ 85	\$ 19
	Large	24 x 39"	RDEFZ39-73P	<input type="checkbox"/>	<input type="checkbox"/>	<input type="checkbox"/>	<input type="checkbox"/>	<input type="checkbox"/>	<input type="checkbox"/>	<input type="checkbox"/>	44.0#	536	85	19

A **B** **C** **D** **E** **F** **G** **H**

HOW TO ORDER

- Indicate the following information on order form:
- Quantity of each item.
 - Model number, including options. See "How To Build a Model Number".
 - Any special service required.

Note: • The indicates that a choice is required.
 • The absence of the indicates that no choice is required.
 • Alpha-numeric characters in place of indicate that no other alternatives are available.

HOW TO BUILD A MODEL NUMBER

- A** Select basic model/edge style.
73P - 3/4" laminate top w/73P edge band
- B** Select edge color.
 Refer to the **Product Color Options** page in this price list.
- C** Select surface finish.
 Refer to the **Product Color Options** page in this price list.
- D** Select base finish.
 Refer to the **Product Color Options** page in this price list.
- E** Select base option.
CCC - Casters
BCF - Casters/felt glides
BCN - Casters/nylon glides
GFT - Felt glides
GNV - Nylon glides
- F** Select under table storage.
NB - No book storage
BBS - Poly book box, small; add \$34
BBL - Poly book box, large; add \$39
BR - Book basket; add \$50
RT - Removable storage tote; add \$51
SBBS - Steel book box, small; add \$73
SBBL - Steel book box, large; add \$84
 BBL & SBBL options are not available on the small desk sizes.
- G** Select book basket color.
 Refer to the **Product Color Options** page in this price list.
 Only if book basket (BR) storage is selected.
- H** Select steel book box color.
 Refer to the **Product Color Options** page in this price list.
 Only if steel book box (SBBS or SBBL) storage is selected.

FINISH INFORMATION

Additional Laminate Offering
 KI offers laminates beyond those offered in the standard offering. Laminates that are currently available in the program can be viewed in KI product specification tools. Requests to add laminates to the program can be submitted via the product modification request process. Please note, requests to add laminates to the program must include the laminate manufacturer's name, color/pattern number, and finish code. Edge options are limited to standard edge colors. If a matching edge is required, this will need to be requested through the product modification request process and may be subject to additional costs. Due to varying manufacturing processes and quality issues with some laminates, some requests may be denied. Extended lead times and minimum order quantities may apply on orders containing special laminates. Contact the product modification team for questions or additional information regarding special laminates and pricing.

SPECIAL SERVICES

Special Carton Marking
 With specially marked information N/C

Shipping
 Ships **knocked down, FOB Bonduel, WI 54107, freight prepaid.** Freight class 70.

Specifications and prices are subject to change without prior notice.

Ruckus® Post-Leg Desk (Delivered Pricing)

3/4" Top - 73P Edge



Ruckus® Post-Leg Desk (Delivered Pricing)

3/4" Top - 73P Edge

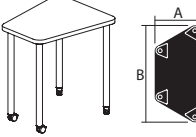
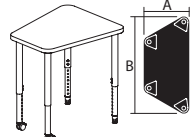
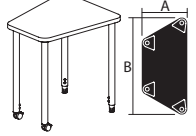
MODEL	A x B	MODEL NUMBER								Approx. Packaged Weight	Delivered Pricing	Chrome Upcharge add to list price	Laminate Grade 2 add to list price	
		Basic Model/Edge Style	Edge Color	Surface Finish	Base Finish	Base Option	Under Table Storage	Book Basket Color	Book Box Color					
 <p>Fixed Height Pentaquad Desk, 28-1/2" H • Casters and glides are interchangeable • Ruckus post leg desks require assembly • All corners of surface are rounded • Specify casters/glides to wheelbarrow • Configures into pods of four or five desks</p>	26 x 30"	RDEAS2630-73P	<input type="checkbox"/>	<input type="checkbox"/>	<input type="checkbox"/>	<input type="checkbox"/>	<input type="checkbox"/>	<input type="checkbox"/>	<input type="checkbox"/>	<input type="checkbox"/>	58.00#	\$ 445	\$ 68	\$ 27
RDEAS														
 <p>Sit Height Adjustable Pentaquad Desk, 19-1/2 to 32-1/2" H • Casters and glides are interchangeable • Ruckus post leg desks require assembly • All corners of surface are rounded • Specify casters/glides to wheelbarrow • Legs adjust with screws in 1" increments • Legs are factory pre-set at 28.5"H • Configures into pods of four or five desks</p>	26 x 30"	RDEES2630-73P	<input type="checkbox"/>	<input type="checkbox"/>	<input type="checkbox"/>	<input type="checkbox"/>	<input type="checkbox"/>	<input type="checkbox"/>	<input type="checkbox"/>	<input type="checkbox"/>	60.00#	\$ 501	\$ 74	\$ 27
RDEES														
 <p>Sit-Stand Height Adjustable Pentaquad Desk, 28-1/2 to 41-1/2" H • Casters and glides are interchangeable • Ruckus post leg desks require assembly • All corners of surface are rounded • Specify casters/glides to wheelbarrow • Legs adjust with screws in 1" increments • Legs are factory pre-set at 28.5"H • Configures into pods of four or five desks</p>	26 x 30"	RDEFS2630-73P	<input type="checkbox"/>	<input type="checkbox"/>	<input type="checkbox"/>	<input type="checkbox"/>	<input type="checkbox"/>	<input type="checkbox"/>	<input type="checkbox"/>	<input type="checkbox"/>	64.00#	\$ 536	\$ 85	\$ 27
RDEFS														

A **B** **C** **D** **E** **F** **G** **H**

HOW TO ORDER

- Indicate the following information on order form:
- Quantity of each item.
 - Model number, including options. See "How To Build a Model Number".
 - Any special service required.

Note: • The indicates that a choice is required.
 • The absence of the indicates that no choice is required.
 • Alpha-numeric characters in place of indicate that no other alternatives are available.

HOW TO BUILD A MODEL NUMBER

- A** Select basic model/edge style.
73P - 3/4" laminate top w/73P edge band
- B** Select edge color.
 Refer to the **Product Color Options** page in this price list.
- C** Select surface finish.
 Refer to the **Product Color Options** page in this price list.
- D** Select base finish.
 Refer to the **Product Color Options** page in this price list.
- E** Select base option.
BCF - Casters/felt glides
BCN - Casters/nylon glides
GFT - Felt glides
GNY - Nylon glides
CCC - Casters

- F** Select under table storage.
NB - No book storage
BBS - Poly book box, small; add \$34
BBL - Poly book box, large; add \$39
BR - Book basket; add \$50
RT - Removable storage tote; add \$51
SBBS - Steel book box, small; add \$73
SBBL - Steel book box, large; add \$84
 BBL & SBBL options are not available on the small desk sizes.
- G** Select book basket color.
 Refer to the **Product Color Options** page in this price list.
 Only if book basket (BR) storage is selected.
- H** Select steel book box color.
 Refer to the **Product Color Options** page in this price list.
 Only if steel book box (SBBS or SBBL) storage is selected.

FINISH INFORMATION

Additional Laminate Offering

KI offers laminates beyond those offered in the standard offering. Laminates that are currently available in the program can be viewed in KI product specification tools. Requests to add laminates to the program can be submitted via the product modification request process. Please note, requests to add laminates to the program must include the laminate manufacturer's name, color/pattern number, and finish code. Edge options are limited to standard edge colors. If a matching edge is required, this will need to be requested through the product modification request process and may be subject to additional costs. Due to varying manufacturing processes and quality issues with some laminates, some requests may be denied. Extended lead times and minimum order quantities may apply on orders containing special laminates. Contact the product modification team for questions or additional information regarding special laminates and pricing.

SPECIAL SERVICES

Special Carton Marking

With specially marked information N/C

Shipping
 Ships **knocked down, FOB Bonduel, WI 54107, freight prepaid**. Freight class 70.

Specifications and prices are subject to change without prior notice.

Ruckus® Post-Leg Desk (Delivered Pricing)

1-1/4" Top - 74P Edge



Ruckus® Post-Leg Desk (Delivered Pricing)

1-1/4" Top - 74P Edge

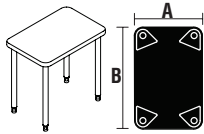
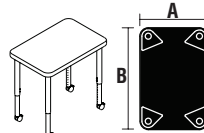
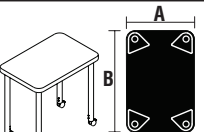
MODEL	A x B	MODEL NUMBER								Approx. Packaged Weight	Delivered Pricing	Chrome Upcharge add to list price	Laminate Grade 2 add to list price
		Basic Model/Edge Style	Edge Color	Surface Finish	Base Finish	Base Option	Under Table Storage	Book Basket Color	Book Box Color				
 <p>Fixed Height Rectangular Desk, 29" H</p> <ul style="list-style-type: none"> • Casters and glides are interchangeable • Ruckus post-leg desks require assembly • All corners of surface are rounded • Specify casters/glides to wheelbarrow 	20 x 30"	RDEEA2030-74P	□□□	□□□	□□	□□□	□□□	□□□□	□□□	42.8#	\$ 456	\$ 68	\$ 19
	20 x 36"	RDEEA2036-74P	□□□	□□□	□□	□□□	□□□	□□□□	□□□	47.0#	492	68	19
	24 x 36"	RDEEA2436-74P	□□□	□□□	□□	□□□	□□□	□□□□	□□□	52.0#	507	68	19
 <p>Sit Height Adjustable Rectangular Desk, 20 to 33" H</p> <ul style="list-style-type: none"> • Casters and glides are interchangeable • Ruckus post-leg desks require assembly • All corners of surface are rounded • Specify casters/glides to wheelbarrow • Legs adjust with screws in 1" increments • Legs are factory pre-set at 29"H • 20 x 37" desk is ADA compliant 	20 x 30"	RDEEA2030-74P	□□□	□□□	□□	□□□	□□□	□□□□	□□□	44.8#	\$ 506	\$ 74	\$ 19
	20 x 36"	RDEEA2036-74P	□□□	□□□	□□	□□□	□□□	□□□□	□□□	49.0#	541	74	19
	24 x 36"	RDEEA2436-74P	□□□	□□□	□□	□□□	□□□	□□□□	□□□	54.0#	550	74	19
	20 x 37"	RDEEA2037ADA-74P	□□□	□□□	□□	□□□	□□□	□□□□	□□□	49.7#	561	74	19
 <p>Sit-Stand Height Adjustable Rectangular Desk, 29 to 42" H</p> <ul style="list-style-type: none"> • Casters and glides are interchangeable • Ruckus post-leg desks require assembly • All corners of surface are rounded • Specify casters/glides to wheelbarrow • Legs adjust with screws in 1" increments • Legs are factory pre-set at 29"H • 20 x 37" desk is ADA compliant 	20 x 30"	RDEFA2030-74P	□□□	□□□	□□	□□□	□□□	□□□□	□□□	48.8#	\$ 545	\$ 85	\$ 19
	20 x 36"	RDEFA2036-74P	□□□	□□□	□□	□□□	□□□	□□□□	□□□	53.0#	569	85	19
	24 x 36"	RDEFA2436-74P	□□□	□□□	□□	□□□	□□□	□□□□	□□□	58.0#	579	85	19
	20 x 37"	RDEFA2037ADA-74P	□□□	□□□	□□	□□□	□□□	□□□□	□□□	53.7#	591	85	19

A B C D E F G H

HOW TO ORDER

- Indicate the following information on order form:
1. Quantity of each item.
 2. Model number, including options. See "How To Build a Model Number".
 3. Any special service required.

Note: • The □ indicates that a choice is required.
 • The absence of the □ indicates that no choice is required.
 • Alpha-numeric characters in place of □ indicate that no other alternatives are available.

HOW TO BUILD A MODEL NUMBER

- A** Select basic model/edge style.
74P - 1-1/4" laminate top w/74P edge band
- B** Select edge color.
 Refer to the **Product Color Options** page in this price list.
- C** Select surface finish.
 Refer to the **Product Color Options** page in this price list.
- D** Select base finish.
 Refer to the **Product Color Options** page in this price list.
- E** Select base option.
CCC - Casters
BCF - Casters/felt glides
BCN - Casters/nylon glides
GFT - Felt glides
GNV - Nylon glides

- F** Select under table storage.
NB - No book storage
BBS - Poly book box, small; add \$34
BBL - Poly book box, large; add \$39
BR - Book basket; add \$50
RT - Removable storage tote; add \$51
SBBS - Steel book box, small; add \$73
SBBL - Steel book box, large; add \$84
 BBL & SBBL options are not available on the small desk sizes.
- G** Select book basket color.
 Refer to the **Product Color Options** page in this price list.
 Only if book basket (BR) storage is selected.
- H** Select steel book box color.
 Refer to the **Product Color Options** page in this price list.
 Only if steel book box (SBBS or SBBL) storage is selected.

FINISH INFORMATION

Additional Laminate Offering

KI offers laminates beyond those offered in the standard offering. Laminates that are currently available in the program can be viewed in KI product specification tools. Requests to add laminates to the program can be submitted via the product modification request process. Please note, requests to add laminates to the program must include the laminate manufacturer's name, color/pattern number, and finish code. Edge options are limited to standard edge colors. If a matching edge is required, this will need to be requested through the product modification request process and may be subject to additional costs. Due to varying manufacturing processes and quality issues with some laminates, some requests may be denied. Extended lead times and minimum order quantities may apply on orders containing special laminates. Contact the product modification team for questions or additional information regarding special laminates and pricing.

SPECIAL SERVICES

Special Carton Marking

With specially marked information N/C

Shipping

Ships **knocked down, FOB Bonduel, WI 54107, freight prepaid.** Freight class 70.

Specifications and prices are subject to change without prior notice.

Ruckus® Post-Leg Desk (Delivered Pricing)

1-1/4" Top - 74P Edge



Ruckus® Post-Leg Desk (Delivered Pricing)

1-1/4" Top - 74P Edge

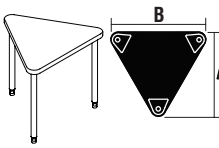
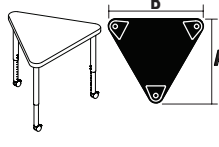
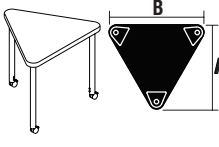
MODEL	Features	A x B	MODEL NUMBER								Approx. Packaged Weight	Delivered Pricing	Chrome Upcharge add to list price	Laminate Grade 2 add to list price	
			Basic Model/Edge Style	Edge Color	Surface Finish	Base Finish	Base Option	Under Table Storage	Book Basket Color	Book Box Color					
 RDEAK	Fixed Height E-Triangle Desk, 29" H • Casters and glides are interchangeable • Ruckus post-leg desks require assembly • All corners of surface are rounded • Specify casters/glides to wheelbarrow • 6 Desks combine to form an hexagon	Small 28 x 32"	RDEAK32-74P	<input type="checkbox"/>	<input type="checkbox"/>	<input type="checkbox"/>	<input type="checkbox"/>	<input type="checkbox"/>	<input type="checkbox"/>	<input type="checkbox"/>	<input type="checkbox"/>	29.0#	\$ 463	\$ 51	\$ 27
		Large 33 x 37"	RDEAK37-74P	<input type="checkbox"/>	<input type="checkbox"/>	<input type="checkbox"/>	<input type="checkbox"/>	<input type="checkbox"/>	<input type="checkbox"/>	<input type="checkbox"/>	<input type="checkbox"/>	<input type="checkbox"/>	33.0#	534	51
 RDEEK	Sit Height Adjustable E-Triangle Desk, 20 to 33" H • Casters and glides are interchangeable • Ruckus post-leg desks require assembly • All corners of surface are rounded • Specify casters/glides to wheelbarrow • Legs adjust with screws in 1" increments • Legs are factory pre-set at 29"H • 6 Desks combine to form an hexagon	Small 28 x 32"	RDEEK32-74P	<input type="checkbox"/>	<input type="checkbox"/>	<input type="checkbox"/>	<input type="checkbox"/>	<input type="checkbox"/>	<input type="checkbox"/>	<input type="checkbox"/>	<input type="checkbox"/>	30.5#	\$ 498	\$ 56	\$ 27
		Large 33 x 37"	RDEEK37-74P	<input type="checkbox"/>	<input type="checkbox"/>	<input type="checkbox"/>	<input type="checkbox"/>	<input type="checkbox"/>	<input type="checkbox"/>	<input type="checkbox"/>	<input type="checkbox"/>	<input type="checkbox"/>	34.5#	568	56
 RDEFK	Sit-Stand Height Adjustable E-Triangle Desk, 29 to 42" H • Casters and glides are interchangeable • Ruckus post-leg desks require assembly • All corners of surface are rounded • Specify casters/glides to wheelbarrow • Legs adjust with screws in 1" increments • Legs are factory pre-set at 29"H • 6 Desks combine to form an hexagon	Small 28 x 32"	RDEFK32-74P	<input type="checkbox"/>	<input type="checkbox"/>	<input type="checkbox"/>	<input type="checkbox"/>	<input type="checkbox"/>	<input type="checkbox"/>	<input type="checkbox"/>	<input type="checkbox"/>	33.5#	\$ 534	\$ 65	\$ 27
		Large 33 x 37"	RDEFK37-74P	<input type="checkbox"/>	<input type="checkbox"/>	<input type="checkbox"/>	<input type="checkbox"/>	<input type="checkbox"/>	<input type="checkbox"/>	<input type="checkbox"/>	<input type="checkbox"/>	<input type="checkbox"/>	37.5#	608	65

A **B** **C** **D** **E** **F** **G** **H**

HOW TO ORDER

- Indicate the following information on order form:
- Quantity of each item.
 - Model number, including options. See "How To Build a Model Number".
 - Any special service required.

Note: • The indicates that a choice is required.

- The absence of the indicates that no choice is required.
- Alpha-numeric characters in place of indicate that no other alternatives are available.

HOW TO BUILD A MODEL NUMBER

- A** Select basic model/edge style.
74P - 1-1/4" laminate top w/74P edge band
- B** Select edge color.
 Refer to the **Product Color Options** page in this price list.
- C** Select surface finish.
 Refer to the **Product Color Options** page in this price list.
- D** Select base finish.
 Refer to the **Product Color Options** page in this price list.
- E** Select base option.
CCC - Casters
BCF - Casters/felt glides
BCN - Casters/nylon glides
GFT - Felt glides
GNV - Nylon glides

- F** Select under table storage.
NB - No book storage
BBS - Poly book box, small; add \$34
BBL - Poly book box, large; add \$39
BR - Book basket; add \$50
RT - Removable storage tote; add \$51
SBBS - Steel book box, small; add \$73
SBBL - Steel book box, large; add \$84
 BBL & SBBL options are not available on the small desk sizes.
- G** Select book basket color.
 Refer to the **Product Color Options** page in this price list.
 Only if book basket (BR) storage is selected.
- H** Select steel book box color.
 Refer to the **Product Color Options** page in this price list.
 Only if steel book box (SBBS or SBBL) storage is selected.

FINISH INFORMATION

Additional Laminate Offering

KI offers laminates beyond those offered in the standard offering. Laminates that are currently available in the program can be viewed in KI product specification tools. Requests to add laminates to the program can be submitted via the product modification request process. Please note, requests to add laminates to the program must include the laminate manufacturer's name, color/pattern number, and finish code. Edge options are limited to standard edge colors. If a matching edge is required, this will need to be requested through the product modification request process and may be subject to additional costs. Due to varying manufacturing processes and quality issues with some laminates, some requests may be denied. Extended lead times and minimum order quantities may apply on orders containing special laminates. Contact the product modification team for questions or additional information regarding special laminates and pricing.

SPECIAL SERVICES

Special Carton Marking

With specially marked information N/C

Shipping

Ships **knocked down, FOB Bonduel, WI 54107, freight prepaid**. Freight class 70.

Specifications and prices are subject to change without prior notice.

Ruckus® Post-Leg Desk (Delivered Pricing)

1-1/4" Top - 74P Edge



Ruckus® Post-Leg Desk (Delivered Pricing)

1-1/4" Top - 74P Edge

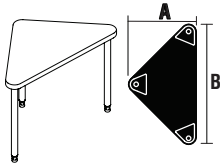
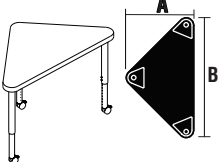
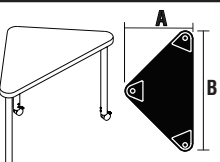
MODEL	Features	A x B	MODEL NUMBER								Approx. Packaged Weight	Delivered Pricing	Chrome Upcharge add to list price	Laminate Grade 2 add to list price	
			Basic Model/Edge Style	Edge Color	Surface Finish	Base Finish	Base Option	Under Table Storage	Book Basket Color	Book Box Color					
 <p>Fixed Height R-Triangle Desk, 29" H</p> <ul style="list-style-type: none"> • Casters and glides are interchangeable • Ruckus post-leg desks require assembly • All corners of surface are rounded • Specify casters/glides to wheelbarrow • 4 Desks combine to form a square 	Small	22 x 39"	RDEAL39-74P	<input type="checkbox"/>	<input type="checkbox"/>	<input type="checkbox"/>	<input type="checkbox"/>	<input type="checkbox"/>	<input type="checkbox"/>	<input type="checkbox"/>	<input type="checkbox"/>	29.0#	\$ 458	\$ 51	\$ 19
	Large	26 x 47"	RDEAL47-74P	<input type="checkbox"/>	<input type="checkbox"/>	<input type="checkbox"/>	<input type="checkbox"/>	<input type="checkbox"/>	<input type="checkbox"/>	<input type="checkbox"/>	<input type="checkbox"/>	33.0#	491	51	27
RDEAL															
 <p>Sit Height Adjustable R-Triangle Desk, 20 to 33" H</p> <ul style="list-style-type: none"> • Casters and glides are interchangeable • Ruckus post-leg desks require assembly • All corners of surface are rounded • Specify casters/glides to wheelbarrow • Legs adjust with screws in 1" increments • Legs are factory pre-set at 29"H • 4 Desks combine to form a square 	Small	22 x 39"	RDEEL39-74P	<input type="checkbox"/>	<input type="checkbox"/>	<input type="checkbox"/>	<input type="checkbox"/>	<input type="checkbox"/>	<input type="checkbox"/>	<input type="checkbox"/>	<input type="checkbox"/>	30.5#	\$ 493	\$ 56	\$ 19
	Large	26 x 47"	RDEEL47-74P	<input type="checkbox"/>	<input type="checkbox"/>	<input type="checkbox"/>	<input type="checkbox"/>	<input type="checkbox"/>	<input type="checkbox"/>	<input type="checkbox"/>	<input type="checkbox"/>	34.5#	526	56	27
RDEEL															
 <p>Sit-Stand Height Adjustable R-Triangle Desk, 29 to 42" H</p> <ul style="list-style-type: none"> • Casters and glides are interchangeable • Ruckus post-leg desks require assembly • All corners of surface are rounded • Specify casters/glides to wheelbarrow • Legs adjust with screws in 1" increments • Legs are factory pre-set at 29"H • 4 Desks combine to form a square 	Small	22 x 39"	RDEFL39-74P	<input type="checkbox"/>	<input type="checkbox"/>	<input type="checkbox"/>	<input type="checkbox"/>	<input type="checkbox"/>	<input type="checkbox"/>	<input type="checkbox"/>	<input type="checkbox"/>	33.5#	\$ 530	\$ 65	\$ 19
	Large	26 x 47"	RDEFL47-74P	<input type="checkbox"/>	<input type="checkbox"/>	<input type="checkbox"/>	<input type="checkbox"/>	<input type="checkbox"/>	<input type="checkbox"/>	<input type="checkbox"/>	<input type="checkbox"/>	37.5#	562	65	27
RDEFL															

A B C D E F G H

HOW TO ORDER

- Indicate the following information on order form:
1. Quantity of each item.
 2. Model number, including options. See "How To Build a Model Number".
 3. Any special service required.

Note: • The indicates that a choice is required.

- The absence of the indicates that no choice is required.
- Alpha-numeric characters in place of indicate that no other alternatives are available.

HOW TO BUILD A MODEL NUMBER

- A** Select basic model/edge style.
74P - 1-1/4" laminate top w/74P edge band
- B** Select edge color.
 Refer to the **Product Color Options** page in this price list.
- C** Select surface finish.
 Refer to the **Product Color Options** page in this price list.
- D** Select base finish.
 Refer to the **Product Color Options** page in this price list.
- E** Select base option.
- CCC** - Casters
 - BCF** - Casters/felt glides
 - BCN** - Casters/nylon glides
 - GFT** - Felt glides
 - GNV** - Nylon glides

- F** Select under table storage.
- NB** - No book storage
 - BBS** - Poly book box, small; add \$34
 - BBL** - Poly book box, large; add \$39
 - BR** - Book basket; add \$50
 - RT** - Removable storage tote; add \$51
 - SBBS** - Steel book box, small; add \$73
 - SBBL** - Steel book box, large; add \$84
- BBL & SBBL options are not available on the small desk sizes.
- G** Select book basket color.
 Refer to the **Product Color Options** page in this price list.
 Only if book basket (BR) storage is selected.
- H** Select steel book box color.
 Refer to the **Product Color Options** page in this price list.
 Only if steel book box (SBBS or SBBL) storage is selected.

FINISH INFORMATION

Additional Laminate Offering

KI offers laminates beyond those offered in the standard offering. Laminates that are currently available in the program can be viewed in KI product specification tools. Requests to add laminates to the program can be submitted via the product modification request process. Please note, requests to add laminates to the program must include the laminate manufacturer's name, color/pattern number, and finish code. Edge options are limited to standard edge colors. If a matching edge is required, this will need to be requested through the product modification request process and may be subject to additional costs. Due to varying manufacturing processes and quality issues with some laminates, some requests may be denied. Extended lead times and minimum order quantities may apply on orders containing special laminates. Contact the product modification team for questions or additional information regarding special laminates and pricing.

SPECIAL SERVICES

Special Carton Marking

With specially marked information N/C

Shipping

Ships **knocked down, FOB Bonduel, WI 54107, freight prepaid**. Freight class 70.

Specifications and prices are subject to change without prior notice.

Ruckus® Post-Leg Desk (Delivered Pricing)

1-1/4" Top - 74P Edge



Ruckus® Post-Leg Desk (Delivered Pricing)

1-1/4" Top - 74P Edge

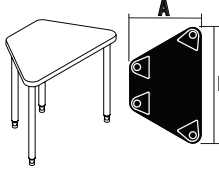
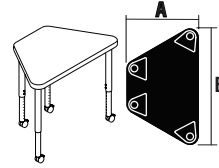
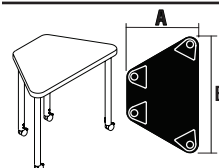
MODEL	Features	A x B	MODEL NUMBER								Approx. Packaged Weight	Delivered Pricing	Chrome Upcharge add to list price	Laminate Grade 2 add to list price	
			Basic Model/Edge Style	Edge Color	Surface Finish	Base Finish	Base Option	Under Table Storage	Book Basket Color	Book Box Color					
 RDEAM Fixed Height Trapezoid Desk, 29" H • Casters and glides are interchangeable • Ruckus post-leg desks require assembly • All corners of surface are rounded • Specify casters/glides to wheelbarrow • 6 Desks combine to form a hexagon	Small	21 x 34"	RDEAM34-74P	<input type="checkbox"/>	<input type="checkbox"/>	<input type="checkbox"/>	<input type="checkbox"/>	<input type="checkbox"/>	<input type="checkbox"/>	<input type="checkbox"/>	<input type="checkbox"/>	35.0#	\$ 497	\$ 68	\$ 19
	Large	24 x 37"	RDEAM37-74P	<input type="checkbox"/>	<input type="checkbox"/>	<input type="checkbox"/>	<input type="checkbox"/>	<input type="checkbox"/>	<input type="checkbox"/>	<input type="checkbox"/>	<input type="checkbox"/>	38.0#	516	68	19
 RDEEM Sit Height Adjustable Trapezoid Desk, 20 to 33" H • Casters and glides are interchangeable • Ruckus post-leg desks require assembly • All corners of surface are rounded • Specify casters/glides to wheelbarrow • Legs adjust with screws in 1" increments • Legs are factory pre-set at 29"H • 6 Desks combine to form a hexagon	Small	21 x 34"	RDEEM34-74P	<input type="checkbox"/>	<input type="checkbox"/>	<input type="checkbox"/>	<input type="checkbox"/>	<input type="checkbox"/>	<input type="checkbox"/>	<input type="checkbox"/>	<input type="checkbox"/>	37.0#	\$ 539	\$ 74	\$ 19
	Large	24 x 37"	RDEEM37-74P	<input type="checkbox"/>	<input type="checkbox"/>	<input type="checkbox"/>	<input type="checkbox"/>	<input type="checkbox"/>	<input type="checkbox"/>	<input type="checkbox"/>	<input type="checkbox"/>	40.0#	559	74	19
 RDEFM Sit-Stand Height Adjustable Trapezoid Desk, 29 to 42" H • Casters and glides are interchangeable • Ruckus post-leg desks require assembly • All corners of surface are rounded • Specify casters/glides to wheelbarrow • Legs adjust with screws in 1" increments • Legs are factory pre-set at 29"H • 6 Desks combine to form a hexagon	Small	21 x 34"	RDEFM34-74P	<input type="checkbox"/>	<input type="checkbox"/>	<input type="checkbox"/>	<input type="checkbox"/>	<input type="checkbox"/>	<input type="checkbox"/>	<input type="checkbox"/>	<input type="checkbox"/>	41.0#	\$ 575	\$ 85	\$ 19
	Large	24 x 37"	RDEFM37-74P	<input type="checkbox"/>	<input type="checkbox"/>	<input type="checkbox"/>	<input type="checkbox"/>	<input type="checkbox"/>	<input type="checkbox"/>	<input type="checkbox"/>	<input type="checkbox"/>	44.0#	596	85	19

A **B** **C** **D** **E** **F** **G** **H**

HOW TO ORDER

- Indicate the following information on order form:
- Quantity of each item.
 - Model number, including options. See "How To Build a Model Number".
 - Any special service required.

Note: • The indicates that a choice is required.
 • The absence of the indicates that no choice is required.
 • Alpha-numeric characters in place of indicate that no other alternatives are available.

HOW TO BUILD A MODEL NUMBER

- A** Select basic model/edge style.
74P - 1-1/4" laminate top w/74P edge band
- B** Select edge color.
 Refer to the **Product Color Options** page in this price list.
- C** Select surface finish.
 Refer to the **Product Color Options** page in this price list.
- D** Select base finish.
 Refer to the **Product Color Options** page in this price list.
- E** Select base option.
CCC - Casters
BCF - Casters/felt glides
BCN - Casters/nylon glides
GFT - Felt glides
GNV - Nylon glides

- F** Select under table storage.
NB - No book storage
BBS - Poly book box, small; add \$34
BBL - Poly book box, large; add \$39
BR - Book basket; add \$50
RT - Removable storage tote; add \$51
SBBS - Steel book box, small; add \$73
SBBL - Steel book box, large; add \$84
 BBL & SBBL options are not available on the small desk sizes.
- G** Select book basket color.
 Refer to the **Product Color Options** page in this price list.
 Only if book basket (BR) storage is selected.
- H** Select steel book box color.
 Refer to the **Product Color Options** page in this price list.
 Only if steel book box (SBBS or SBBL) storage is selected.

FINISH INFORMATION

Additional Laminate Offering

KI offers laminates beyond those offered in the standard offering. Laminates that are currently available in the program can be viewed in KI product specification tools. Requests to add laminates to the program can be submitted via the product modification request process. Please note, requests to add laminates to the program must include the laminate manufacturer's name, color/pattern number, and finish code. Edge options are limited to standard edge colors. If a matching edge is required, this will need to be requested through the product modification request process and may be subject to additional costs. Due to varying manufacturing processes and quality issues with some laminates, some requests may be denied. Extended lead times and minimum order quantities may apply on orders containing special laminates. Contact the product modification team for questions or additional information regarding special laminates and pricing.

SPECIAL SERVICES

Special Carton Marking

With specially marked information N/C

Shipping

Ships **knocked down, FOB Bonduel, WI 54107, freight prepaid**. Freight class 70.

Specifications and prices are subject to change without prior notice.

Ruckus® Post-Leg Desk (Delivered Pricing)

1-1/4" Top - 74P Edge



Ruckus® Post-Leg Desk (Delivered Pricing)

1-1/4" Top - 74P Edge

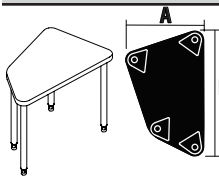
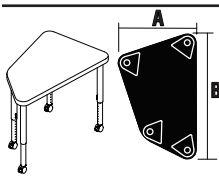
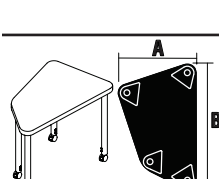
MODEL	Features	A x B	MODEL NUMBER								Approx. Packaged Weight	Delivered Pricing	Chrome Upcharge add to list price	Laminate Grade 2 add to list price	
			Basic Model/Edge Style	Edge Color	Surface Finish	Base Finish	Base Option	Under Table Storage	Book Basket Color	Book Box Color					
 Fixed Height Oddquad Desk, 29" H • Casters and glides are interchangeable • Ruckus post-leg desks require assembly • All corners of surface are rounded • Specify casters/glides to wheelbarrow • 4 Desks combine to form a pin-wheel RDEAZ	Small	22 x 36"	RDEAZ36-74P	<input type="checkbox"/>	<input type="checkbox"/>	<input type="checkbox"/>	<input type="checkbox"/>	<input type="checkbox"/>	<input type="checkbox"/>	<input type="checkbox"/>	<input type="checkbox"/>	35.0#	\$ 502	\$ 68	\$ 19
	Large	24 x 39"	RDEAZ39-74P	<input type="checkbox"/>	<input type="checkbox"/>	<input type="checkbox"/>	<input type="checkbox"/>	<input type="checkbox"/>	<input type="checkbox"/>	<input type="checkbox"/>	<input type="checkbox"/>	38.0#	526	68	19
 Sit Height Adjustable Oddquad Desk, 20 to 33" H • Casters and glides are interchangeable • Ruckus post-leg desks require assembly • All corners of surface are rounded • Specify casters/glides to wheelbarrow • Legs adjust with screws in 1" increments • Legs are factory pre-set at 29"H • 4 Desks combine to form a pin-wheel RDEEZ	Small	22 x 36"	RDEEZ36-74P	<input type="checkbox"/>	<input type="checkbox"/>	<input type="checkbox"/>	<input type="checkbox"/>	<input type="checkbox"/>	<input type="checkbox"/>	<input type="checkbox"/>	<input type="checkbox"/>	37.0#	\$ 543	\$ 74	\$ 19
	Large	24 x 39"	RDEEZ39-74P	<input type="checkbox"/>	<input type="checkbox"/>	<input type="checkbox"/>	<input type="checkbox"/>	<input type="checkbox"/>	<input type="checkbox"/>	<input type="checkbox"/>	<input type="checkbox"/>	40.0#	568	74	19
 Sit-Stand Height Adjustable Oddquad Desk, 29 to 42" H • Casters and glides are interchangeable • Ruckus post-leg desks require assembly • All corners of surface are rounded • Specify casters/glides to wheelbarrow • Legs adjust with screws in 1" increments • Legs are factory pre-set at 29"H • 4 Desks combine to form a pin-wheel RDEFZ	Small	22 x 36"	RDEFZ36-74P	<input type="checkbox"/>	<input type="checkbox"/>	<input type="checkbox"/>	<input type="checkbox"/>	<input type="checkbox"/>	<input type="checkbox"/>	<input type="checkbox"/>	<input type="checkbox"/>	41.0#	\$ 581	\$ 85	\$ 19
	Large	24 x 39"	RDEFZ39-74P	<input type="checkbox"/>	<input type="checkbox"/>	<input type="checkbox"/>	<input type="checkbox"/>	<input type="checkbox"/>	<input type="checkbox"/>	<input type="checkbox"/>	<input type="checkbox"/>	44.0#	607	85	19

A B C D E F G H

HOW TO ORDER

- Indicate the following information on order form:
- Quantity of each item.
 - Model number, including options. See "How To Build a Model Number".
 - Any special service required.

Note: • The indicates that a choice is required.

- The absence of the indicates that no choice is required.
- Alpha-numeric characters in place of indicate that no other alternatives are available.

HOW TO BUILD A MODEL NUMBER

- A** Select basic model/edge style.
74P - 1-1/4" laminate top w/74P edge band
- B** Select edge color.
 Refer to the **Product Color Options** page in this price list.
- C** Select surface finish.
 Refer to the **Product Color Options** page in this price list.
- D** Select base finish.
 Refer to the **Product Color Options** page in this price list.
- E** Select base option.
CCC - Casters
BCF - Casters/felt glides
BCN - Casters/nylon glides
GFT - Felt glides
GNV - Nylon glides

- F** Select under table storage.
NB - No book storage
BBS - Poly book box, small; add \$34
BBL - Poly book box, large; add \$39
BR - Book basket; add \$50
RT - Removable storage tote; add \$51
SBBS - Steel book box, small; add \$73
SBBL - Steel book box, large; add \$84
 BBL & SBBL options are not available on the small desk sizes.
- G** Select book basket color.
 Refer to the **Product Color Options** page in this price list.
 Only if book basket (BR) storage is selected.
- H** Select steel book box color.
 Refer to the **Product Color Options** page in this price list.
 Only if steel book box (SBBS or SBBL) storage is selected.

FINISH INFORMATION

Additional Laminate Offering

KI offers laminates beyond those offered in the standard offering. Laminates that are currently available in the program can be viewed in KI product specification tools. Requests to add laminates to the program can be submitted via the product modification request process. Please note, requests to add laminates to the program must include the laminate manufacturer's name, color/pattern number, and finish code. Edge options are limited to standard edge colors. If a matching edge is required, this will need to be requested through the product modification request process and may be subject to additional costs. Due to varying manufacturing processes and quality issues with some laminates, some requests may be denied. Extended lead times and minimum order quantities may apply on orders containing special laminates. Contact the product modification team for questions or additional information regarding special laminates and pricing.

SPECIAL SERVICES

Special Carton Marking

With specially marked information N/C

Shipping
 Ships **knocked down, FOB Bonduel, WI 54107, freight prepaid**. Freight class 70.

Specifications and prices are subject to change without prior notice.

Ruckus® Post-Leg Desk (Delivered Pricing)

1-1/4" Top - 74P Edge



Ruckus® Post-Leg Desk (Delivered Pricing)

1-1/4" Top - 74P Edge

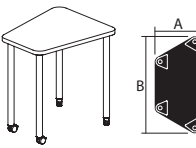
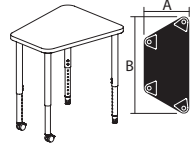
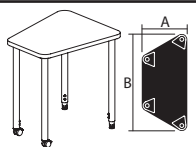
MODEL	A x B	MODEL NUMBER								Approx. Packaged Weight	Delivered Pricing	Chrome Upcharge add to list price	Laminate Grade 2 add to list price	
		Basic Model/Edge Style	Edge Color	Surface Finish	Base Finish	Base Option	Under Table Storage	Book Basket Color	Book Box Color					
 <p>Fixed Height Pentaquad Desk, 29" H • Casters and glides are interchangeable • Ruckus post leg desks require assembly • All corners of surface are rounded • Specify casters/glides to wheelbarrow • Configures into pods of four or five desks</p>	26 x 30"	RDEAS2630-74P	<input type="checkbox"/>	<input type="checkbox"/>	<input type="checkbox"/>	<input type="checkbox"/>	<input type="checkbox"/>	<input type="checkbox"/>	<input type="checkbox"/>	<input type="checkbox"/>	58.00#	\$ 514	\$ 68	\$ 27
RDEAS														
 <p>Sit Height Adjustable Pentaquad Desk, 20 to 33" H • Casters and glides are interchangeable • Ruckus post leg desks require assembly • All corners of surface are rounded • Specify casters/glides to wheelbarrow • Configures into pods of four or five desks</p>	26 x 30"	RDEES2630-74P	<input type="checkbox"/>	<input type="checkbox"/>	<input type="checkbox"/>	<input type="checkbox"/>	<input type="checkbox"/>	<input type="checkbox"/>	<input type="checkbox"/>	<input type="checkbox"/>	60.00#	\$ 570	\$ 74	\$ 27
RDEES														
 <p>29 to 42" Sit-Stand Height Adjustable Pentaquad Desk • Casters and glides are interchangeable • Ruckus post leg desks require assembly • All corners of surface are rounded • Specify casters/glides to wheelbarrow • Legs adjust with screws in 1" increments • Legs are factory pre-set at 29"H • Configures into pods of four or five desks</p>	26 x 30"	RDEFS2630-74P	<input type="checkbox"/>	<input type="checkbox"/>	<input type="checkbox"/>	<input type="checkbox"/>	<input type="checkbox"/>	<input type="checkbox"/>	<input type="checkbox"/>	<input type="checkbox"/>	64.00#	\$ 605	\$ 85	\$ 27
RDEFS														

A B C D E F G H

HOW TO ORDER

- Indicate the following information on order form:
- Quantity of each item.
 - Model number, including options. See "How To Build a Model Number".
 - Any special service required.

Note: • The indicates that a choice is required.
 • The absence of the indicates that no choice is required.
 • Alpha-numeric characters in place of indicate that no other alternatives are available.

HOW TO BUILD A MODEL NUMBER

- A** Select basic model/edge style.
74P - 1-1/4" laminate top w/74P edge band
- B** Select edge color.
 Refer to the **Product Color Options** page in this price list.
- C** Select surface finish.
 Refer to the **Product Color Options** page in this price list.
- D** Select base finish.
 Refer to the **Product Color Options** page in this price list.
- E** Select base option.
BCF - Casters/felt glides
BCN - Casters/nylon glides
GFT - Felt glides
GNY - Nylon glides
CCC - Casters

- F** Select under table storage.
NB - No book storage
BBS - Poly book box, small; add \$34
BBL - Poly book box, large; add \$39
BR - Book basket; add \$50
RT - Removable storage tote; add \$51
SBBS - Steel book box, small; add \$73
SBBL - Steel book box, large; add \$84
 BBL & SBBL options are not available on the small desk sizes.
- G** Select book basket color.
 Refer to the **Product Color Options** page in this price list.
 Only if book basket (BR) storage is selected.
- H** Select steel book box color.
 Refer to the **Product Color Options** page in this price list.
 Only if steel book box (SBBS or SBBL) storage is selected.

FINISH INFORMATION

Additional Laminate Offering

KI offers laminates beyond those offered in the standard offering. Laminates that are currently available in the program can be viewed in KI product specification tools. Requests to add laminates to the program can be submitted via the product modification request process. Please note, requests to add laminates to the program must include the laminate manufacturer's name, color/pattern number, and finish code. Edge options are limited to standard edge colors. If a matching edge is required, this will need to be requested through the product modification request process and may be subject to additional costs. Due to varying manufacturing processes and quality issues with some laminates, some requests may be denied. Extended lead times and minimum order quantities may apply on orders containing special laminates. Contact the product modification team for questions or additional information regarding special laminates and pricing.

SPECIAL SERVICES

Special Carton Marking

With specially marked information N/C

Shipping
 Ships **knocked down, FOB Bonduel, WI 54107, freight prepaid**. Freight class 70.

Specifications and prices are subject to change without prior notice.



MODEL	MODEL NUMBER	Approx. Packaged Weight	Delivered Pricing
	Basic Model		
 <p>Book Bag Hook</p> <ul style="list-style-type: none"> • 1/4" solid wire rod • Chrome finish • Field installable • Includes 2 screws 	RKUSBBH1	3.0#	\$ 10

RKAU

A

HOW TO ORDER

- Indicate the following information on order form:
1. Quantity of each item.
 2. Model number, including options. See "How To Build a Model Number".
 3. Any special service required.

- Note:
- The indicates that a choice is required.
 - The absence of the indicates that no choice is required.
 - Alpha-numeric characters in place of indicate that no other alternatives are available.

HOW TO BUILD A MODEL NUMBER

- A** Select basic model.

SPECIAL SERVICES

Special Carton Marking

With specially marked information N/C

Shipping

Ships **knocked down, FOB Bonduel, WI 54107, freight prepaid.** Freight class 85.

Specifications and prices are subject to change without prior notice.

Ruckus® Activity Table (Delivered Pricing)

3/4" Top - 73P Edge



Ruckus® Activity Table (Delivered Pricing)

3/4" Top - 73P Edge

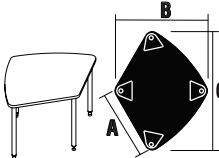
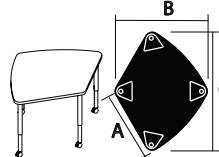
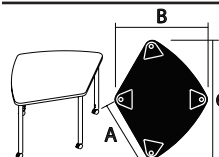
MODEL	A x B x C	MODEL NUMBER					Approx. Packaged Weight	Delivered Pricing	Chrome Upcharge add to list price	Laminate Grade 2 add to list price
		Basic Model/Edge Style	Edge Color	Surface Finish	Base Finish	Base Option				
 <p>Fixed Height Diamond Table, 28-1/2" H</p> <ul style="list-style-type: none"> • Casters and glides are interchangeable • Tables are designed for maximum leg spacing • All corners of surface are rounded • Specify casters/glides to wheelbarrow • 3 tables combine to form a guitar pick 	30 x 39 x 50"	RTEAE30-73P	<input type="checkbox"/>	<input type="checkbox"/>	<input type="checkbox"/>	48.00#	\$ 728	\$ 70	\$ 53	
	36 x 47 x 60"	RTEAE36-73P	<input type="checkbox"/>	<input type="checkbox"/>	<input type="checkbox"/>	59.00#	788	70	53	
RTEAE										
 <p>Sit Height Adjustable Diamond Table, 19-1/2 to 32-1/2" H</p> <ul style="list-style-type: none"> • Casters and glides are interchangeable • Tables are designed for maximum leg spacing • All corners of surface are rounded • Specify casters/glides to wheelbarrow • Legs adjust with screws in 1" increments • Legs are factory pre-set at 28-1/2"H • 3 tables combine to form a guitar pick 	30 x 39 x 50"	RTEEE30-73P	<input type="checkbox"/>	<input type="checkbox"/>	<input type="checkbox"/>	50.00#	\$ 785	\$ 77	\$ 53	
	36 x 47 x 60"	RTEEE36-73P	<input type="checkbox"/>	<input type="checkbox"/>	<input type="checkbox"/>	61.00#	847	77	53	
RTEEE										
 <p>Sit-Stand Height Adjustable Diamond Table, 28-1/2 to 41-1/2" H</p> <ul style="list-style-type: none"> • Casters and glides are interchangeable • Tables are designed for maximum leg spacing • All corners of surface are rounded • Specify casters/glides to wheelbarrow • Legs adjust with screws in 1" increments • Legs are factory pre-set at 28-1/2"H • 3 tables combine to form a guitar pick 	30 x 39 x 50"	RTEFE30-73P	<input type="checkbox"/>	<input type="checkbox"/>	<input type="checkbox"/>	54.00#	\$ 827	\$ 88	\$ 53	
	36 x 47 x 60"	RTEFE36-73P	<input type="checkbox"/>	<input type="checkbox"/>	<input type="checkbox"/>	65.00#	892	88	53	
RTEFE										

A B C D E

HOW TO ORDER

- Indicate the following information on order form:
1. Quantity of each item.
 2. Model number, including options. See "How To Build a Model Number".
 3. Any special service required.

Note: • The indicates that a choice is required.

- The absence of the indicates that no choice is required.
- Alpha-numeric characters in place of indicate that no other alternatives are available.

HOW TO BUILD A MODEL NUMBER

- A** Select basic model/edge style.
73P - 3/4" laminate top w/73P edge band
- B** Select edge color.
Refer to the **Product Color Options** page in this price list.
- C** Select surface finish.
Refer to the **Product Color Options** page in this price list.
- D** Select base finish.
Refer to the **Product Color Options** page in this price list.
- E** Select base option.
- | | |
|------------|------------------------|
| CCC | - Casters |
| BCF | - Casters/felt glides |
| BCN | - Casters/nylon glides |
| GFT | - Felt glides |
| GNY | - Nylon glides |

FINISH INFORMATION

Additional Laminate Offering

KI offers laminates beyond those offered in the standard offering. Laminates that are currently available in the program can be viewed in KI product specification tools. Requests to add laminates to the program can be submitted via the product modification request process. Please note, requests to add laminates to the program must include the laminate manufacturer's name, color/pattern number, and finish code. Edge options are limited to standard edge colors. If a matching edge is required, this will need to be requested through the product modification request process and may be subject to additional costs. Due to varying manufacturing processes and quality issues with some laminates, some requests may be denied. Extended lead times and minimum order quantities may apply on orders containing special laminates. Contact the product modification team for questions or additional information regarding special laminates and pricing.

SPECIAL SERVICES

Special Carton Marking

With specially marked information N/C

Shipping

Ships **knocked down, FOB Bonduel, WI 54107, freight prepaid.** Freight class 70.

Specifications and prices are subject to change without prior notice.

Ruckus® Activity Table (Delivered Pricing)

3/4" Top - 73P Edge



Ruckus® Activity Table (Delivered Pricing)

3/4" Top - 73P Edge

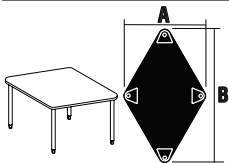
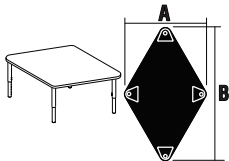
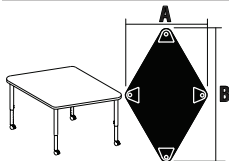
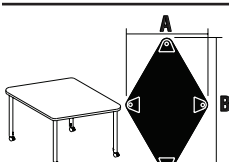
MODEL	Features	A x B	MODEL NUMBER					Approx. Packaged Weight	Delivered Pricing	Chrome Upcharge add to list price	Laminate Grade 2 add to list price
			Basic Model/Edge Style	Edge Color	Surface Finish	Base Finish	Base Option				
 <p>Fixed Height Kite Table, 28-1/2" H</p> <ul style="list-style-type: none"> • Casters and glides are interchangeable • Tables are designed for maximum leg spacing • All corners of surface are rounded • Specify casters/glides to wheelbarrow • 3 Tables combine to form a hexagon 	Small	35 x 57"	RTEAJ34-73P	<input type="checkbox"/> <input type="checkbox"/> <input type="checkbox"/>	<input type="checkbox"/> <input type="checkbox"/> <input type="checkbox"/>	<input type="checkbox"/> <input type="checkbox"/>	<input type="checkbox"/> <input type="checkbox"/> <input type="checkbox"/>	47.00#	\$ 736	\$ 70	\$ 53
	Large	40 x 66"	RTEAJ39-73P	<input type="checkbox"/> <input type="checkbox"/> <input type="checkbox"/>	<input type="checkbox"/> <input type="checkbox"/> <input type="checkbox"/>	<input type="checkbox"/> <input type="checkbox"/>	<input type="checkbox"/> <input type="checkbox"/> <input type="checkbox"/>	55.00#	839	70	53
RTEAJ											
 <p>Floor Height Adjustable Kite Table, 11-1/2 to 18-1/2" H</p> <ul style="list-style-type: none"> • Tables are designed for maximum leg spacing • All corners of surface are rounded • Legs adjust with screws in 1" increments • Legs are factory pre-set at 18-1/2" H • 3 Tables combine to form a hexagon • Base only available in glides 	Small	35 x 57"	RTEHJ34-73P	<input type="checkbox"/> <input type="checkbox"/> <input type="checkbox"/>	<input type="checkbox"/> <input type="checkbox"/> <input type="checkbox"/>	<input type="checkbox"/> <input type="checkbox"/>	<input type="checkbox"/> <input type="checkbox"/> <input type="checkbox"/>	44.50#	\$ 812	\$ 75	\$ 53
	Large	40 x 66"	RTEHJ39-73P	<input type="checkbox"/> <input type="checkbox"/> <input type="checkbox"/>	<input type="checkbox"/> <input type="checkbox"/> <input type="checkbox"/>	<input type="checkbox"/> <input type="checkbox"/>	<input type="checkbox"/> <input type="checkbox"/> <input type="checkbox"/>	52.50#	914	75	53
RTEHJ											
 <p>Sit Height Adjustable Kite Table, 19-1/2 to 32-1/2" H</p> <ul style="list-style-type: none"> • Casters and glides are interchangeable • Tables are designed for maximum leg spacing • All corners of surface are rounded • Specify casters/glides to wheelbarrow • Legs adjust with screws in 1" increments • Legs are factory pre-set at 28-1/2" H • 3 Tables combine to form a hexagon 	Small	35 x 57"	RTEEJ34-73P	<input type="checkbox"/> <input type="checkbox"/> <input type="checkbox"/>	<input type="checkbox"/> <input type="checkbox"/> <input type="checkbox"/>	<input type="checkbox"/> <input type="checkbox"/>	<input type="checkbox"/> <input type="checkbox"/> <input type="checkbox"/>	49.00#	\$ 783	\$ 77	\$ 53
	Large	40 x 66"	RTEEJ39-73P	<input type="checkbox"/> <input type="checkbox"/> <input type="checkbox"/>	<input type="checkbox"/> <input type="checkbox"/> <input type="checkbox"/>	<input type="checkbox"/> <input type="checkbox"/>	<input type="checkbox"/> <input type="checkbox"/> <input type="checkbox"/>	57.00#	881	77	53
RTEEJ											
 <p>Sit-Stand Height Adjustable Kite Table, 28-1/2 to 41-1/2" H</p> <ul style="list-style-type: none"> • Casters and glides are interchangeable • Tables are designed for maximum leg spacing • All corners of surface are rounded • Specify casters/glides to wheelbarrow • Legs adjust with screws in 1" increments • Legs are factory pre-set at 28-1/2" H • 3 Tables combine to form a hexagon 	Small	35 x 57"	RTEFJ34-73P	<input type="checkbox"/> <input type="checkbox"/> <input type="checkbox"/>	<input type="checkbox"/> <input type="checkbox"/> <input type="checkbox"/>	<input type="checkbox"/> <input type="checkbox"/>	<input type="checkbox"/> <input type="checkbox"/> <input type="checkbox"/>	53.00#	\$ 836	\$ 88	\$ 53
	Large	40 x 66"	RTEFJ39-73P	<input type="checkbox"/> <input type="checkbox"/> <input type="checkbox"/>	<input type="checkbox"/> <input type="checkbox"/> <input type="checkbox"/>	<input type="checkbox"/> <input type="checkbox"/>	<input type="checkbox"/> <input type="checkbox"/> <input type="checkbox"/>	61.00#	940	88	53
RTEFJ											

A **B** **C** **D** **E**

HOW TO ORDER

- Indicate the following information on order form:
1. Quantity of each item.
 2. Model number, including options. See "How To Build a Model Number".
 3. Any special service required.

Note: • The indicates that a choice is required.

- The absence of the indicates that no choice is required.
- Alpha-numeric characters in place of indicate that no other alternatives are available.

HOW TO BUILD A MODEL NUMBER

- A** Select basic model/edge style.
73P - 3/4" laminate top w/73P edge band
- B** Select edge color.
Refer to the **Product Color Options** page in this price list.
- C** Select surface finish.
Refer to the **Product Color Options** page in this price list.
- D** Select base finish.
Refer to the **Product Color Options** page in this price list.
- E** Select base option.
CCC - Casters
BCF - Casters/felt glides
BCN - Casters/nylon glides
GFT - Felt glides
GNV - Nylon glides
Base options for Floor Height Adjustable are

ONLY Felt glides - GFT and Nylon glides - GNV

FINISH INFORMATION

Additional Laminate Offering

KI offers laminates beyond those offered in the standard offering. Laminates that are currently available in the program can be viewed in KI product specification tools. Requests to add laminates to the program can be submitted via the product modification request process. Please note, requests to add laminates to the program must include the laminate manufacturer's name, color/pattern number, and finish code. Edge options are limited to standard edge colors. If a matching edge is required, this will need to be requested through the product modification request process and may be subject to additional costs. Due to varying manufacturing processes and quality issues with some laminates, some requests may be denied. Extended lead times and minimum order quantities may apply on orders containing special laminates. Contact the product modification team for questions or additional information regarding special laminates and pricing.

SPECIAL SERVICES

Special Carton Marking

With specially marked information N/C

Shipping

Ships **knocked down, FOB Bonduel, WI 54107, freight prepaid.** Freight class 70.

Specifications and prices are subject to change without prior notice.

Ruckus® Activity Table (Delivered Pricing)

1-1/4" Top - 74P Edge



Ruckus® Activity Table (Delivered Pricing)

1-1/4" Top - 74P Edge

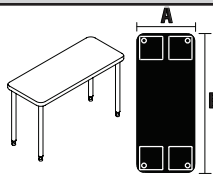
MODEL	A x B	MODEL NUMBER					Approx. Packaged Weight	Delivered Pricing	Chrome Upcharge add to list price	Laminate Grade 2 add to list price
		Basic Model/Edge Style	Edge Color	Surface Finish	Base Finish	Base Option				
 <p>Fixed Height Rectangular Rounded Corners Table, 29" H</p> <ul style="list-style-type: none"> • Casters and glides are interchangeable • Tables are designed for maximum leg spacing • All corners of surface are rounded • Specify casters/glides to wheelbarrow • 42x72, 44x72 and 48x72 have a center leg 	20 x 48"	RTEAA2048	<input type="checkbox"/>	<input type="checkbox"/>	67.30#	\$ 623	\$ 70	\$ 19		
	20 x 54"	RTEAA2054	<input type="checkbox"/>	<input type="checkbox"/>	71.50#	642	70	19		
	20 x 60"	RTEAA2060	<input type="checkbox"/>	<input type="checkbox"/>	75.70#	647	70	19		
	20 x 66"	RTEAA2066	<input type="checkbox"/>	<input type="checkbox"/>	81.00#	661	70	19		
	20 x 72"	RTEAA2072	<input type="checkbox"/>	<input type="checkbox"/>	84.00#	669	70	19		
	24 x 30"	RTEAA2430	<input type="checkbox"/>	<input type="checkbox"/>	59.00#	591	70	19		
	24 x 36"	RTEAA2436	<input type="checkbox"/>	<input type="checkbox"/>	64.00#	605	70	19		
	24 x 48"	RTEAA2448	<input type="checkbox"/>	<input type="checkbox"/>	74.00#	623	70	19		
	24 x 54"	RTEAA2454	<input type="checkbox"/>	<input type="checkbox"/>	79.00#	642	70	27		
	24 x 60"	RTEAA2460	<input type="checkbox"/>	<input type="checkbox"/>	84.00#	647	70	27		
	24 x 66"	RTEAA2466	<input type="checkbox"/>	<input type="checkbox"/>	90.00#	663	70	27		
	24 x 72"	RTEAA2472	<input type="checkbox"/>	<input type="checkbox"/>	94.00#	663	70	27		
	30 x 48"	RTEAA3048	<input type="checkbox"/>	<input type="checkbox"/>	84.00#	656	70	27		
	30 x 54"	RTEAA3054	<input type="checkbox"/>	<input type="checkbox"/>	90.30#	682	70	27		
	30 x 60"	RTEAA3060	<input type="checkbox"/>	<input type="checkbox"/>	96.50#	685	70	27		
	30 x 66"	RTEAA3066	<input type="checkbox"/>	<input type="checkbox"/>	104.00#	690	70	27		
	30 x 72"	RTEAA3072	<input type="checkbox"/>	<input type="checkbox"/>	109.00#	689	70	27		
	36 x 54"	RTEAA3654	<input type="checkbox"/>	<input type="checkbox"/>	101.50#	852	70	53		
	36 x 60"	RTEAA3660	<input type="checkbox"/>	<input type="checkbox"/>	109.00#	858	70	53		
	36 x 66"	RTEAA3666	<input type="checkbox"/>	<input type="checkbox"/>	116.00#	864	70	53		
	36 x 72"	RTEAA3672	<input type="checkbox"/>	<input type="checkbox"/>	124.00#	878	70	53		
	42 x 60"	RTEAA4260	<input type="checkbox"/>	<input type="checkbox"/>	121.50#	883	70	53		
	42 x 66"	RTEAA4266	<input type="checkbox"/>	<input type="checkbox"/>	128.00#	892	70	53		
	42 x 72"	RTEAA4272	<input type="checkbox"/>	<input type="checkbox"/>	139.00#	883	70	53		
	44 x 60"	RTEAA4460	<input type="checkbox"/>	<input type="checkbox"/>	125.70#	1067	70	53		
	44 x 66"	RTEAA4466	<input type="checkbox"/>	<input type="checkbox"/>	138.00#	1077	70	53		
	44 x 72"	RTEAA4472	<input type="checkbox"/>	<input type="checkbox"/>	144.00#	1067	70	53		
	48 x 60"	RTEAA4860	<input type="checkbox"/>	<input type="checkbox"/>	136.00#	1143	70	53		
48 x 66"	RTEAA4866	<input type="checkbox"/>	<input type="checkbox"/>	148.00#	1156	70	53			
48 x 72"	RTEAA4872	<input type="checkbox"/>	<input type="checkbox"/>	149.00#	1168	70	53			

A **B** **C** **D** **E**

HOW TO ORDER

- Indicate the following information on order form:
1. Quantity of each item.
 2. Model number, including options. See "How To Build a Model Number".
 3. Any special service required.

Note: • The indicates that a choice is required.
 • The absence of the indicates that no choice is required.
 • Alpha-numeric characters in place of indicate that no other alternatives are available.

HOW TO BUILD A MODEL NUMBER

- A** Select basic model/edge style.
74P - 1-1/4" laminate top w/74P edge band
- B** Select edge color.
 Refer to the **Product Color Options** page in this price list.
- C** Select surface finish.
 Refer to the **Product Color Options** page in this price list.
- D** Select base finish.
 Refer to the **Product Color Options** page in this price list.
- E** Select base option.

CCC	- Casters
BCF	- Casters/felt glides
BCN	- Casters/nylon glides
GFT	- Felt glides
GNV	- Nylon glides

FINISH INFORMATION

Additional Laminate Offering
 KI offers laminates beyond those offered in the standard offering. Laminates that are currently available in the program can be viewed in KI product specification tools. Requests to add laminates to the program can be submitted via the product modification request process. Please note, requests to add laminates to the program must include the laminate manufacturer's name, color/pattern number, and finish code. Edge options are limited to standard edge colors. If a matching edge is required, this will need to be requested through the product modification request process and may be subject to additional costs. Due to varying manufacturing processes and quality issues with some laminates, some requests may be denied. Extended lead times and minimum order quantities may apply on orders containing special laminates. Contact the product modification team for questions or additional information regarding special laminates and pricing.

SPECIAL SERVICES

Special Carton Marking

With specially marked information N/C

Shipping
 Ships **knocked down, FOB Bonduel, WI 54107, freight prepaid.** Freight class 70.

Specifications and prices are subject to change without prior notice.

Ruckus® Activity Table (Delivered Pricing)

1-1/4" Top - 74P Edge



Ruckus® Activity Table (Delivered Pricing)

1-1/4" Top - 74P Edge

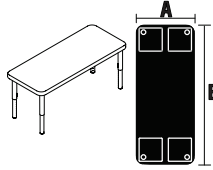
MODEL	A x B	MODEL NUMBER					Approx. Packaged Weight	Delivered Pricing	Chrome Upcharge add to list price	Laminate Grade 2 add to list price
		Basic Model/Edge Style	Edge Color	Surface Finish	Base Finish	Base Option				
 <p>RTEHA</p> <p>Floor Height Adjustable Rectangle Rounded Corners Table, 12 to 19" H</p> <ul style="list-style-type: none"> • Tables are designed for maximum leg spacing • All corners of surface are rounded • Legs adjust with screws in 1" increments • Legs are factory pre-set at 29"H • Base only available in glides 	20 x 48"	RTEHA2048	<input type="checkbox"/> <input type="checkbox"/> <input type="checkbox"/>	<input type="checkbox"/> <input type="checkbox"/> <input type="checkbox"/>	<input type="checkbox"/> <input type="checkbox"/>	<input type="checkbox"/> <input type="checkbox"/> <input type="checkbox"/>	64.80#	\$ 688	\$ 75	\$ 19
	20 x 54"	RTEHA2054	<input type="checkbox"/> <input type="checkbox"/> <input type="checkbox"/>	<input type="checkbox"/> <input type="checkbox"/> <input type="checkbox"/>	<input type="checkbox"/> <input type="checkbox"/>	<input type="checkbox"/> <input type="checkbox"/> <input type="checkbox"/>	79.00#	695	75	19
	20 x 60"	RTEHA2060	<input type="checkbox"/> <input type="checkbox"/> <input type="checkbox"/>	<input type="checkbox"/> <input type="checkbox"/> <input type="checkbox"/>	<input type="checkbox"/> <input type="checkbox"/>	<input type="checkbox"/> <input type="checkbox"/> <input type="checkbox"/>	73.20#	692	75	19
	20 x 66"	RTEHA2066	<input type="checkbox"/> <input type="checkbox"/> <input type="checkbox"/>	<input type="checkbox"/> <input type="checkbox"/> <input type="checkbox"/>	<input type="checkbox"/> <input type="checkbox"/>	<input type="checkbox"/> <input type="checkbox"/> <input type="checkbox"/>	78.50#	706	75	19
	20 x 72"	RTEHA2072	<input type="checkbox"/> <input type="checkbox"/> <input type="checkbox"/>	<input type="checkbox"/> <input type="checkbox"/> <input type="checkbox"/>	<input type="checkbox"/> <input type="checkbox"/>	<input type="checkbox"/> <input type="checkbox"/> <input type="checkbox"/>	81.50#	712	75	19
	24 x 36"	RTEHA2436	<input type="checkbox"/> <input type="checkbox"/> <input type="checkbox"/>	<input type="checkbox"/> <input type="checkbox"/> <input type="checkbox"/>	<input type="checkbox"/> <input type="checkbox"/>	<input type="checkbox"/> <input type="checkbox"/> <input type="checkbox"/>	61.50#	674	75	19
	24 x 42"	RTEHA2442	<input type="checkbox"/> <input type="checkbox"/> <input type="checkbox"/>	<input type="checkbox"/> <input type="checkbox"/> <input type="checkbox"/>	<input type="checkbox"/> <input type="checkbox"/>	<input type="checkbox"/> <input type="checkbox"/> <input type="checkbox"/>	66.50#	688	75	19
	24 x 48"	RTEHA2448	<input type="checkbox"/> <input type="checkbox"/> <input type="checkbox"/>	<input type="checkbox"/> <input type="checkbox"/> <input type="checkbox"/>	<input type="checkbox"/> <input type="checkbox"/>	<input type="checkbox"/> <input type="checkbox"/> <input type="checkbox"/>	71.50#	690	75	19
	24 x 54"	RTEHA2454	<input type="checkbox"/> <input type="checkbox"/> <input type="checkbox"/>	<input type="checkbox"/> <input type="checkbox"/> <input type="checkbox"/>	<input type="checkbox"/> <input type="checkbox"/>	<input type="checkbox"/> <input type="checkbox"/> <input type="checkbox"/>	76.50#	692	75	27
	24 x 60"	RTEHA2460	<input type="checkbox"/> <input type="checkbox"/> <input type="checkbox"/>	<input type="checkbox"/> <input type="checkbox"/> <input type="checkbox"/>	<input type="checkbox"/> <input type="checkbox"/>	<input type="checkbox"/> <input type="checkbox"/> <input type="checkbox"/>	81.50#	695	75	27
	24 x 66"	RTEHA2466	<input type="checkbox"/> <input type="checkbox"/> <input type="checkbox"/>	<input type="checkbox"/> <input type="checkbox"/> <input type="checkbox"/>	<input type="checkbox"/> <input type="checkbox"/>	<input type="checkbox"/> <input type="checkbox"/> <input type="checkbox"/>	87.50#	708	75	27
	24 x 72"	RTEHA2472	<input type="checkbox"/> <input type="checkbox"/> <input type="checkbox"/>	<input type="checkbox"/> <input type="checkbox"/> <input type="checkbox"/>	<input type="checkbox"/> <input type="checkbox"/>	<input type="checkbox"/> <input type="checkbox"/> <input type="checkbox"/>	91.50#	715	75	27
	30 x 42"	RTEHA3042	<input type="checkbox"/> <input type="checkbox"/> <input type="checkbox"/>	<input type="checkbox"/> <input type="checkbox"/> <input type="checkbox"/>	<input type="checkbox"/> <input type="checkbox"/>	<input type="checkbox"/> <input type="checkbox"/> <input type="checkbox"/>	78.50#	731	75	27
	30 x 48"	RTEHA3048	<input type="checkbox"/> <input type="checkbox"/> <input type="checkbox"/>	<input type="checkbox"/> <input type="checkbox"/> <input type="checkbox"/>	<input type="checkbox"/> <input type="checkbox"/>	<input type="checkbox"/> <input type="checkbox"/> <input type="checkbox"/>	81.50#	736	75	27
	30 x 54"	RTEHA3054	<input type="checkbox"/> <input type="checkbox"/> <input type="checkbox"/>	<input type="checkbox"/> <input type="checkbox"/> <input type="checkbox"/>	<input type="checkbox"/> <input type="checkbox"/>	<input type="checkbox"/> <input type="checkbox"/> <input type="checkbox"/>	87.80#	740	75	27
	30 x 60"	RTEHA3060	<input type="checkbox"/> <input type="checkbox"/> <input type="checkbox"/>	<input type="checkbox"/> <input type="checkbox"/> <input type="checkbox"/>	<input type="checkbox"/> <input type="checkbox"/>	<input type="checkbox"/> <input type="checkbox"/> <input type="checkbox"/>	94.00#	744	75	27
	30 x 66"	RTEHA3066	<input type="checkbox"/> <input type="checkbox"/> <input type="checkbox"/>	<input type="checkbox"/> <input type="checkbox"/> <input type="checkbox"/>	<input type="checkbox"/> <input type="checkbox"/>	<input type="checkbox"/> <input type="checkbox"/> <input type="checkbox"/>	102.50#	747	75	27
	30 x 72"	RTEHA3072	<input type="checkbox"/> <input type="checkbox"/> <input type="checkbox"/>	<input type="checkbox"/> <input type="checkbox"/> <input type="checkbox"/>	<input type="checkbox"/> <input type="checkbox"/>	<input type="checkbox"/> <input type="checkbox"/> <input type="checkbox"/>	106.50#	751	75	27
	36 x 54"	RTEHA3654	<input type="checkbox"/> <input type="checkbox"/> <input type="checkbox"/>	<input type="checkbox"/> <input type="checkbox"/> <input type="checkbox"/>	<input type="checkbox"/> <input type="checkbox"/>	<input type="checkbox"/> <input type="checkbox"/> <input type="checkbox"/>	99.00#	888	75	53
	36 x 60"	RTEHA3660	<input type="checkbox"/> <input type="checkbox"/> <input type="checkbox"/>	<input type="checkbox"/> <input type="checkbox"/> <input type="checkbox"/>	<input type="checkbox"/> <input type="checkbox"/>	<input type="checkbox"/> <input type="checkbox"/> <input type="checkbox"/>	106.50#	890	75	53
36 x 66"	RTEHA3666	<input type="checkbox"/> <input type="checkbox"/> <input type="checkbox"/>	<input type="checkbox"/> <input type="checkbox"/> <input type="checkbox"/>	<input type="checkbox"/> <input type="checkbox"/>	<input type="checkbox"/> <input type="checkbox"/> <input type="checkbox"/>	113.50#	899	75	53	
36 x 72"	RTEHA3672	<input type="checkbox"/> <input type="checkbox"/> <input type="checkbox"/>	<input type="checkbox"/> <input type="checkbox"/> <input type="checkbox"/>	<input type="checkbox"/> <input type="checkbox"/>	<input type="checkbox"/> <input type="checkbox"/> <input type="checkbox"/>	121.50#	902	75	53	

A **B** **C** **D** **E**

HOW TO ORDER

- Indicate the following information on order form:
- Quantity of each item.
 - Model number, including options. See "How To Build a Model Number".
 - Any special service required.

Note: • The indicates that a choice is required.
 • The absence of the indicates that no choice is required.
 • Alpha-numeric characters in place of indicate that no other alternatives are available.

HOW TO BUILD A MODEL NUMBER

- A** Select basic model/edge style.
74P - 1-1/4" laminate top w/74P edge band
- B** Select edge color.
 Refer to the **Product Color Options** page in this price list.
- C** Select surface finish.
 Refer to the **Product Color Options** page in this price list.
- D** Select base finish.
 Refer to the **Product Color Options** page in this price list.
- E** Select base option.
GFT - Felt glides
GNV - Nylon glides

FINISH INFORMATION

Additional Laminate Offering

KI offers laminates beyond those offered in the standard offering. Laminates that are currently available in the program can be viewed in KI product specification tools. Requests to add laminates to the program can be submitted via the product modification request process. Please note, requests to add laminates to the program must include the laminate manufacturer's name, color/pattern number, and finish code. Edge options are limited to standard edge colors. If a matching edge is required, this will need to be requested through the product modification request process and may be subject to additional costs. Due to varying manufacturing processes and quality issues with some laminates, some requests may be denied. Extended lead times and minimum order quantities may apply on orders containing special laminates. Contact the product modification team for questions or additional information regarding special laminates and pricing.

SPECIAL SERVICES

Special Carton Marking

With specially marked information N/C

Shipping

Ships **knocked down, FOB Bonduel, WI 54107, freight prepaid.** Freight class 70.

Specifications and prices are subject to change without prior notice.

Ruckus® Activity Table (Delivered Pricing)

1-1/4" Top - 74P Edge



Ruckus® Activity Table (Delivered Pricing)

1-1/4" Top - 74P Edge

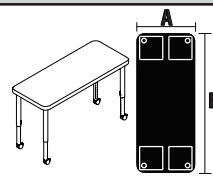
MODEL	A x B	MODEL NUMBER					Approx. Packaged Weight	Delivered Pricing	Chrome Upcharge add to list price	Laminate Grade 2 add to list price
		Basic Model/Edge Style	Edge Color	Surface Finish	Base Finish	Base Option				
 <p>Sit Height Adjustable Rectangular Rounded Corners Table, 20 to 33" H</p> <ul style="list-style-type: none"> • Casters and glides are interchangeable • Tables are designed for maximum leg spacing • All corners of surface are rounded • Specify casters/glides to wheelbarrow • Legs adjust with screws in 1" increments • Legs are factory pre-set at 29"H • 42x72, 44x72 and 48x72 have a center leg 	20 x 48"	RTEEA2048	<input type="checkbox"/>	<input type="checkbox"/>	<input type="checkbox"/>	69.30#	\$ 670	\$ 77	\$ 19	
	20 x 54"	RTEEA2054	<input type="checkbox"/>	<input type="checkbox"/>	<input type="checkbox"/>	73.50#	690	77	19	
	20 x 60"	RTEEA2060	<input type="checkbox"/>	<input type="checkbox"/>	<input type="checkbox"/>	77.70#	691	77	19	
	20 x 66"	RTEEA2066	<input type="checkbox"/>	<input type="checkbox"/>	<input type="checkbox"/>	83.00#	706	77	19	
	20 x 72"	RTEEA2072	<input type="checkbox"/>	<input type="checkbox"/>	<input type="checkbox"/>	86.00#	715	77	19	
	24 x 30"	RTEEA2430	<input type="checkbox"/>	<input type="checkbox"/>	<input type="checkbox"/>	61.00#	640	77	19	
	24 x 36"	RTEEA2436	<input type="checkbox"/>	<input type="checkbox"/>	<input type="checkbox"/>	66.00#	652	77	19	
	24 x 48"	RTEEA2448	<input type="checkbox"/>	<input type="checkbox"/>	<input type="checkbox"/>	76.00#	670	77	19	
	24 x 54"	RTEEA2454	<input type="checkbox"/>	<input type="checkbox"/>	<input type="checkbox"/>	81.00#	690	77	27	
	24 x 60"	RTEEA2460	<input type="checkbox"/>	<input type="checkbox"/>	<input type="checkbox"/>	86.00#	691	77	27	
	24 x 66"	RTEEA2466	<input type="checkbox"/>	<input type="checkbox"/>	<input type="checkbox"/>	92.00#	710	77	27	
	24 x 72"	RTEEA2472	<input type="checkbox"/>	<input type="checkbox"/>	<input type="checkbox"/>	96.00#	708	77	27	
	30 x 48"	RTEEA3048	<input type="checkbox"/>	<input type="checkbox"/>	<input type="checkbox"/>	86.00#	701	77	27	
	30 x 54"	RTEEA3054	<input type="checkbox"/>	<input type="checkbox"/>	<input type="checkbox"/>	92.30#	727	77	27	
	30 x 60"	RTEEA3060	<input type="checkbox"/>	<input type="checkbox"/>	<input type="checkbox"/>	98.50#	728	77	27	
	30 x 66"	RTEEA3066	<input type="checkbox"/>	<input type="checkbox"/>	<input type="checkbox"/>	106.00#	732	77	27	
	30 x 72"	RTEEA3072	<input type="checkbox"/>	<input type="checkbox"/>	<input type="checkbox"/>	111.00#	731	77	27	
	36 x 54"	RTEEA3654	<input type="checkbox"/>	<input type="checkbox"/>	<input type="checkbox"/>	103.50#	892	77	53	
	36 x 60"	RTEEA3660	<input type="checkbox"/>	<input type="checkbox"/>	<input type="checkbox"/>	111.00#	893	77	53	
	36 x 66"	RTEEA3666	<input type="checkbox"/>	<input type="checkbox"/>	<input type="checkbox"/>	118.00#	901	77	53	
	36 x 72"	RTEEA3672	<input type="checkbox"/>	<input type="checkbox"/>	<input type="checkbox"/>	126.00#	913	77	53	
	42 x 60"	RTEEA4260	<input type="checkbox"/>	<input type="checkbox"/>	<input type="checkbox"/>	123.50#	921	77	53	
	42 x 66"	RTEEA4266	<input type="checkbox"/>	<input type="checkbox"/>	<input type="checkbox"/>	130.00#	930	77	53	
	42 x 72"	RTEEA4272	<input type="checkbox"/>	<input type="checkbox"/>	<input type="checkbox"/>	141.00#	921	77	53	
	44 x 60"	RTEEA4460	<input type="checkbox"/>	<input type="checkbox"/>	<input type="checkbox"/>	127.70#	1101	77	53	
	44 x 66"	RTEEA4466	<input type="checkbox"/>	<input type="checkbox"/>	<input type="checkbox"/>	140.00#	1177	77	53	
	44 x 72"	RTEEA4472	<input type="checkbox"/>	<input type="checkbox"/>	<input type="checkbox"/>	146.00#	1101	77	53	
	48 x 60"	RTEEA4860	<input type="checkbox"/>	<input type="checkbox"/>	<input type="checkbox"/>	108.50#	1179	77	53	
48 x 66"	RTEEA4866	<input type="checkbox"/>	<input type="checkbox"/>	<input type="checkbox"/>	115.50#	1193	77	53		
48 x 72"	RTEEA4872	<input type="checkbox"/>	<input type="checkbox"/>	<input type="checkbox"/>	123.50#	1205	77	53		

A **B** **C** **D** **E**

HOW TO ORDER

- Indicate the following information on order form:
1. Quantity of each item.
 2. Model number, including options. See "How To Build a Model Number".
 3. Any special service required.

Note: • The indicates that a choice is required.

- The absence of the indicates that no choice is required.
- Alpha-numeric characters in place of indicate that no other alternatives are available.

HOW TO BUILD A MODEL NUMBER

- A** Select basic model/edge style.
74P - 1-1/4" laminate top w/74P edge band
- B** Select edge color.
 Refer to the **Product Color Options** page in this price list.
- C** Select surface finish.
 Refer to the **Product Color Options** page in this price list.
- D** Select base finish.
 Refer to the **Product Color Options** page in this price list.
- E** Select base option.

CCC	- Casters
BCF	- Casters/felt glides
BCN	- Casters/nylon glides
GFT	- Felt glides
GNV	- Nylon glides

FINISH INFORMATION

Additional Laminate Offering

KI offers laminates beyond those offered in the standard offering. Laminates that are currently available in the program can be viewed in KI product specification tools. Requests to add laminates to the program can be submitted via the product modification request process. Please note, requests to add laminates to the program must include the laminate manufacturer's name, color/pattern number, and finish code. Edge options are limited to standard edge colors. If a matching edge is required, this will need to be requested through the product modification request process and may be subject to additional costs. Due to varying manufacturing processes and quality issues with some laminates, some requests may be denied. Extended lead times and minimum order quantities may apply on orders containing special laminates. Contact the product modification team for questions or additional information regarding special laminates and pricing.

SPECIAL SERVICES

Special Carton Marking

With specially marked information N/C

Shipping

Ships **knocked down, FOB Bonduel, WI 54107, freight prepaid.** Freight class 70.

Specifications and prices are subject to change without prior notice.

Ruckus® Activity Table (Delivered Pricing)

1-1/4" Top - 74P Edge



Ruckus® Activity Table (Delivered Pricing)

1-1/4" Top - 74P Edge

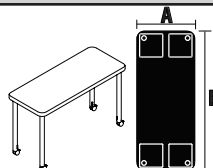
MODEL	A x B	MODEL NUMBER					Approx. Packaged Weight	Delivered Pricing	Chrome Upcharge add to list price	Laminate Grade 2 add to list price
		Basic Model/Edge Style	Edge Color	Surface Finish	Base Finish	Base Option				
 <p>Sit-Stand Height Adjustable Rectangular Rounded Corners Table, 29 to 42" H</p> <ul style="list-style-type: none"> • Casters and glides are interchangeable • Tables are designed for maximum leg spacing • All corners of surface are rounded • Specify casters/glides to wheelbarrow • Legs adjust with screws in 1" increments • Legs are factory pre-set at 29"H • 42x72, 44x72 and 48x72 have a center leg 	20 x 48"	RTEFA2048	<input type="checkbox"/>	<input type="checkbox"/>	<input type="checkbox"/>	<input type="checkbox"/>	73.30#	\$ 722	\$ 88	\$ 19
	20 x 54"	RTEFA2054	<input type="checkbox"/>	<input type="checkbox"/>	<input type="checkbox"/>	<input type="checkbox"/>	77.50#	743	88	19
	20 x 60"	RTEFA2060	<input type="checkbox"/>	<input type="checkbox"/>	<input type="checkbox"/>	<input type="checkbox"/>	81.70#	745	88	19
	20 x 66"	RTEFA2066	<input type="checkbox"/>	<input type="checkbox"/>	<input type="checkbox"/>	<input type="checkbox"/>	87.00#	758	88	19
	20 x 72"	RTEFA2072	<input type="checkbox"/>	<input type="checkbox"/>	<input type="checkbox"/>	<input type="checkbox"/>	90.00#	766	88	19
	24 x 30"	RTEFA2430	<input type="checkbox"/>	<input type="checkbox"/>	<input type="checkbox"/>	<input type="checkbox"/>	65.00#	691	88	19
	24 x 36"	RTEFA2436	<input type="checkbox"/>	<input type="checkbox"/>	<input type="checkbox"/>	<input type="checkbox"/>	70.00#	703	88	19
	24 x 48"	RTEFA2448	<input type="checkbox"/>	<input type="checkbox"/>	<input type="checkbox"/>	<input type="checkbox"/>	80.00#	722	88	19
	24 x 54"	RTEFA2454	<input type="checkbox"/>	<input type="checkbox"/>	<input type="checkbox"/>	<input type="checkbox"/>	85.00#	743	88	27
	24 x 60"	RTEFA2460	<input type="checkbox"/>	<input type="checkbox"/>	<input type="checkbox"/>	<input type="checkbox"/>	90.00#	745	88	27
	24 x 66"	RTEFA2466	<input type="checkbox"/>	<input type="checkbox"/>	<input type="checkbox"/>	<input type="checkbox"/>	96.00#	761	88	27
	24 x 72"	RTEFA2472	<input type="checkbox"/>	<input type="checkbox"/>	<input type="checkbox"/>	<input type="checkbox"/>	100.00#	759	88	27
	30 x 48"	RTEFA3048	<input type="checkbox"/>	<input type="checkbox"/>	<input type="checkbox"/>	<input type="checkbox"/>	90.00#	755	88	27
	30 x 54"	RTEFA3054	<input type="checkbox"/>	<input type="checkbox"/>	<input type="checkbox"/>	<input type="checkbox"/>	96.30#	781	88	27
	30 x 60"	RTEFA3060	<input type="checkbox"/>	<input type="checkbox"/>	<input type="checkbox"/>	<input type="checkbox"/>	102.50#	783	88	27
	30 x 66"	RTEFA3066	<input type="checkbox"/>	<input type="checkbox"/>	<input type="checkbox"/>	<input type="checkbox"/>	110.00#	783	88	27
	30 x 72"	RTEFA3072	<input type="checkbox"/>	<input type="checkbox"/>	<input type="checkbox"/>	<input type="checkbox"/>	115.00#	783	88	27
	36 x 54"	RTEFA3654	<input type="checkbox"/>	<input type="checkbox"/>	<input type="checkbox"/>	<input type="checkbox"/>	107.50#	954	88	53
	36 x 60"	RTEFA3660	<input type="checkbox"/>	<input type="checkbox"/>	<input type="checkbox"/>	<input type="checkbox"/>	115.00#	956	88	53
	36 x 66"	RTEFA3666	<input type="checkbox"/>	<input type="checkbox"/>	<input type="checkbox"/>	<input type="checkbox"/>	122.00#	960	88	53
	36 x 72"	RTEFA3672	<input type="checkbox"/>	<input type="checkbox"/>	<input type="checkbox"/>	<input type="checkbox"/>	130.00#	975	88	53
	42 x 60"	RTEFA4260	<input type="checkbox"/>	<input type="checkbox"/>	<input type="checkbox"/>	<input type="checkbox"/>	127.50#	983	88	53
	42 x 66"	RTEFA4266	<input type="checkbox"/>	<input type="checkbox"/>	<input type="checkbox"/>	<input type="checkbox"/>	134.00#	993	88	53
	42 x 72"	RTEFA4272	<input type="checkbox"/>	<input type="checkbox"/>	<input type="checkbox"/>	<input type="checkbox"/>	145.00#	983	88	53
44 x 60"	RTEFA4460	<input type="checkbox"/>	<input type="checkbox"/>	<input type="checkbox"/>	<input type="checkbox"/>	131.70#	1177	88	53	
44 x 66"	RTEFA4466	<input type="checkbox"/>	<input type="checkbox"/>	<input type="checkbox"/>	<input type="checkbox"/>	144.00#	1188	88	53	
44 x 72"	RTEFA4472	<input type="checkbox"/>	<input type="checkbox"/>	<input type="checkbox"/>	<input type="checkbox"/>	150.00#	1177	88	53	
48 x 60"	RTEFA4860	<input type="checkbox"/>	<input type="checkbox"/>	<input type="checkbox"/>	<input type="checkbox"/>	140.00#	1240	88	53	
48 x 66"	RTEFA4866	<input type="checkbox"/>	<input type="checkbox"/>	<input type="checkbox"/>	<input type="checkbox"/>	152.00#	1253	88	53	
48 x 72"	RTEFA4872	<input type="checkbox"/>	<input type="checkbox"/>	<input type="checkbox"/>	<input type="checkbox"/>	153.00#	1265	88	53	

A **B** **C** **D** **E**

HOW TO ORDER

- Indicate the following information on order form:
1. Quantity of each item.
 2. Model number, including options. See "How To Build a Model Number".
 3. Any special service required.

Note: • The indicates that a choice is required.

- The absence of the indicates that no choice is required.
- Alpha-numeric characters in place of indicate that no other alternatives are available.

HOW TO BUILD A MODEL NUMBER

- A** Select basic model/edge style.
74P - 1-1/4" laminate top w/74P edge band
- B** Select edge color.
Refer to the **Product Color Options** page in this price list.
- C** Select surface finish.
Refer to the **Product Color Options** page in this price list.
- D** Select base finish.
Refer to the **Product Color Options** page in this price list.
- E** Select base option.
 - CCC** - Casters
 - BCF** - Casters/felt glides
 - BCN** - Casters/nylon glides
 - GFT** - Felt glides
 - GNV** - Nylon glides

FINISH INFORMATION

Additional Laminate Offering

KI offers laminates beyond those offered in the standard offering. Laminates that are currently available in the program can be viewed in KI product specification tools. Requests to add laminates to the program can be submitted via the product modification request process. Please note, requests to add laminates to the program must include the laminate manufacturer's name, color/pattern number, and finish code. Edge options are limited to standard edge colors. If a matching edge is required, this will need to be requested through the product modification request process and may be subject to additional costs. Due to varying manufacturing processes and quality issues with some laminates, some requests may be denied. Extended lead times and minimum order quantities may apply on orders containing special laminates. Contact the product modification team for questions or additional information regarding special laminates and pricing.

SPECIAL SERVICES

Special Carton Marking

With specially marked information N/C

Shipping

Ships **knocked down, FOB Bonduel, WI 54107, freight prepaid.** Freight class 70.

Specifications and prices are subject to change without prior notice.

Ruckus® Activity Table (Delivered Pricing)

1-1/4" Top - 74P Edge



Ruckus® Activity Table (Delivered Pricing)

1-1/4" Top - 74P Edge

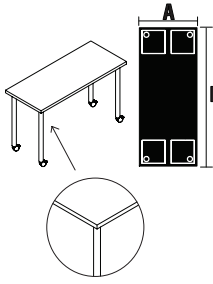
MODEL	A x B	MODEL NUMBER					Approx. Packaged Weight	Delivered Pricing	Chrome Upcharge add to list price	Laminate Grade 2 add to list price
		Basic Model/Edge Style	Edge Color	Surface Finish	Base Finish	Base Option				
 <p>Fixed Height Rectangular Square Corners Table, 29" H</p> <ul style="list-style-type: none"> • Casters and glides are interchangeable • Tables are designed for maximum leg spacing • All corners of surface are squared • Specify casters/glides to wheelbarrow • 42x72, 44x72 and 48x72 have a center leg 	20 x 48"	RXEEA2048	<input type="checkbox"/> <input type="checkbox"/> <input type="checkbox"/>	<input type="checkbox"/> <input type="checkbox"/> <input type="checkbox"/>	<input type="checkbox"/> <input type="checkbox"/>	<input type="checkbox"/> <input type="checkbox"/>	68.00#	\$ 639	\$ 70	\$ 19
	20 x 54"	RXEEA2054	<input type="checkbox"/> <input type="checkbox"/> <input type="checkbox"/>	<input type="checkbox"/> <input type="checkbox"/> <input type="checkbox"/>	<input type="checkbox"/> <input type="checkbox"/>	<input type="checkbox"/> <input type="checkbox"/>	72.00#	661	70	19
	20 x 60"	RXEEA2060	<input type="checkbox"/> <input type="checkbox"/> <input type="checkbox"/>	<input type="checkbox"/> <input type="checkbox"/> <input type="checkbox"/>	<input type="checkbox"/> <input type="checkbox"/>	<input type="checkbox"/> <input type="checkbox"/>	77.00#	666	70	19
	20 x 66"	RXEEA2066	<input type="checkbox"/> <input type="checkbox"/> <input type="checkbox"/>	<input type="checkbox"/> <input type="checkbox"/> <input type="checkbox"/>	<input type="checkbox"/> <input type="checkbox"/>	<input type="checkbox"/> <input type="checkbox"/>	82.00#	668	70	19
	20 x 72"	RXEEA2072	<input type="checkbox"/> <input type="checkbox"/> <input type="checkbox"/>	<input type="checkbox"/> <input type="checkbox"/> <input type="checkbox"/>	<input type="checkbox"/> <input type="checkbox"/>	<input type="checkbox"/> <input type="checkbox"/>	85.00#	669	70	19
	24 x 30"	RXEEA2430	<input type="checkbox"/> <input type="checkbox"/> <input type="checkbox"/>	<input type="checkbox"/> <input type="checkbox"/> <input type="checkbox"/>	<input type="checkbox"/> <input type="checkbox"/>	<input type="checkbox"/> <input type="checkbox"/>	60.00#	615	70	19
	24 x 36"	RXEEA2436	<input type="checkbox"/> <input type="checkbox"/> <input type="checkbox"/>	<input type="checkbox"/> <input type="checkbox"/> <input type="checkbox"/>	<input type="checkbox"/> <input type="checkbox"/>	<input type="checkbox"/> <input type="checkbox"/>	65.00#	630	70	19
	24 x 48"	RXEEA2448	<input type="checkbox"/> <input type="checkbox"/> <input type="checkbox"/>	<input type="checkbox"/> <input type="checkbox"/> <input type="checkbox"/>	<input type="checkbox"/> <input type="checkbox"/>	<input type="checkbox"/> <input type="checkbox"/>	75.00#	648	70	19
	24 x 54"	RXEEA2454	<input type="checkbox"/> <input type="checkbox"/> <input type="checkbox"/>	<input type="checkbox"/> <input type="checkbox"/> <input type="checkbox"/>	<input type="checkbox"/> <input type="checkbox"/>	<input type="checkbox"/> <input type="checkbox"/>	80.00#	663	70	27
	24 x 60"	RXEEA2460	<input type="checkbox"/> <input type="checkbox"/> <input type="checkbox"/>	<input type="checkbox"/> <input type="checkbox"/> <input type="checkbox"/>	<input type="checkbox"/> <input type="checkbox"/>	<input type="checkbox"/> <input type="checkbox"/>	85.00#	666	70	27
	24 x 66"	RXEEA2466	<input type="checkbox"/> <input type="checkbox"/> <input type="checkbox"/>	<input type="checkbox"/> <input type="checkbox"/> <input type="checkbox"/>	<input type="checkbox"/> <input type="checkbox"/>	<input type="checkbox"/> <input type="checkbox"/>	91.00#	668	70	27
	24 x 72"	RXEEA2472	<input type="checkbox"/> <input type="checkbox"/> <input type="checkbox"/>	<input type="checkbox"/> <input type="checkbox"/> <input type="checkbox"/>	<input type="checkbox"/> <input type="checkbox"/>	<input type="checkbox"/> <input type="checkbox"/>	95.00#	669	70	27
	30 x 48"	RXEEA3048	<input type="checkbox"/> <input type="checkbox"/> <input type="checkbox"/>	<input type="checkbox"/> <input type="checkbox"/> <input type="checkbox"/>	<input type="checkbox"/> <input type="checkbox"/>	<input type="checkbox"/> <input type="checkbox"/>	85.00#	683	70	27
	30 x 54"	RXEEA3054	<input type="checkbox"/> <input type="checkbox"/> <input type="checkbox"/>	<input type="checkbox"/> <input type="checkbox"/> <input type="checkbox"/>	<input type="checkbox"/> <input type="checkbox"/>	<input type="checkbox"/> <input type="checkbox"/>	91.00#	696	70	27
	30 x 60"	RXEEA3060	<input type="checkbox"/> <input type="checkbox"/> <input type="checkbox"/>	<input type="checkbox"/> <input type="checkbox"/> <input type="checkbox"/>	<input type="checkbox"/> <input type="checkbox"/>	<input type="checkbox"/> <input type="checkbox"/>	98.00#	699	70	27
	30 x 66"	RXEEA3066	<input type="checkbox"/> <input type="checkbox"/> <input type="checkbox"/>	<input type="checkbox"/> <input type="checkbox"/> <input type="checkbox"/>	<input type="checkbox"/> <input type="checkbox"/>	<input type="checkbox"/> <input type="checkbox"/>	105.00#	706	70	27
	30 x 72"	RXEEA3072	<input type="checkbox"/> <input type="checkbox"/> <input type="checkbox"/>	<input type="checkbox"/> <input type="checkbox"/> <input type="checkbox"/>	<input type="checkbox"/> <input type="checkbox"/>	<input type="checkbox"/> <input type="checkbox"/>	110.00#	710	70	27
	36 x 54"	RXEEA3654	<input type="checkbox"/> <input type="checkbox"/> <input type="checkbox"/>	<input type="checkbox"/> <input type="checkbox"/> <input type="checkbox"/>	<input type="checkbox"/> <input type="checkbox"/>	<input type="checkbox"/> <input type="checkbox"/>	103.00#	864	70	53
	36 x 60"	RXEEA3660	<input type="checkbox"/> <input type="checkbox"/> <input type="checkbox"/>	<input type="checkbox"/> <input type="checkbox"/> <input type="checkbox"/>	<input type="checkbox"/> <input type="checkbox"/>	<input type="checkbox"/> <input type="checkbox"/>	110.00#	866	70	53
	36 x 66"	RXEEA3666	<input type="checkbox"/> <input type="checkbox"/> <input type="checkbox"/>	<input type="checkbox"/> <input type="checkbox"/> <input type="checkbox"/>	<input type="checkbox"/> <input type="checkbox"/>	<input type="checkbox"/> <input type="checkbox"/>	117.00#	876	70	53
	36 x 72"	RXEEA3672	<input type="checkbox"/> <input type="checkbox"/> <input type="checkbox"/>	<input type="checkbox"/> <input type="checkbox"/> <input type="checkbox"/>	<input type="checkbox"/> <input type="checkbox"/>	<input type="checkbox"/> <input type="checkbox"/>	125.00#	887	70	53
	42 x 60"	RXEEA4260	<input type="checkbox"/> <input type="checkbox"/> <input type="checkbox"/>	<input type="checkbox"/> <input type="checkbox"/> <input type="checkbox"/>	<input type="checkbox"/> <input type="checkbox"/>	<input type="checkbox"/> <input type="checkbox"/>	123.00#	892	70	53
	42 x 66"	RXEEA4266	<input type="checkbox"/> <input type="checkbox"/> <input type="checkbox"/>	<input type="checkbox"/> <input type="checkbox"/> <input type="checkbox"/>	<input type="checkbox"/> <input type="checkbox"/>	<input type="checkbox"/> <input type="checkbox"/>	129.00#	904	70	53
	42 x 72"	RXEEA4272	<input type="checkbox"/> <input type="checkbox"/> <input type="checkbox"/>	<input type="checkbox"/> <input type="checkbox"/> <input type="checkbox"/>	<input type="checkbox"/> <input type="checkbox"/>	<input type="checkbox"/> <input type="checkbox"/>	140.00#	917	70	53
	44 x 60"	RXEEA4460	<input type="checkbox"/> <input type="checkbox"/> <input type="checkbox"/>	<input type="checkbox"/> <input type="checkbox"/> <input type="checkbox"/>	<input type="checkbox"/> <input type="checkbox"/>	<input type="checkbox"/> <input type="checkbox"/>	127.00#	1077	70	53
	44 x 66"	RXEEA4466	<input type="checkbox"/> <input type="checkbox"/> <input type="checkbox"/>	<input type="checkbox"/> <input type="checkbox"/> <input type="checkbox"/>	<input type="checkbox"/> <input type="checkbox"/>	<input type="checkbox"/> <input type="checkbox"/>	139.00#	1089	70	53
	44 x 72"	RXEEA4472	<input type="checkbox"/> <input type="checkbox"/> <input type="checkbox"/>	<input type="checkbox"/> <input type="checkbox"/> <input type="checkbox"/>	<input type="checkbox"/> <input type="checkbox"/>	<input type="checkbox"/> <input type="checkbox"/>	145.00#	1103	70	53
	48 x 60"	RXEEA4860	<input type="checkbox"/> <input type="checkbox"/> <input type="checkbox"/>	<input type="checkbox"/> <input type="checkbox"/> <input type="checkbox"/>	<input type="checkbox"/> <input type="checkbox"/>	<input type="checkbox"/> <input type="checkbox"/>	137.00#	1143	70	53
48 x 66"	RXEEA4866	<input type="checkbox"/> <input type="checkbox"/> <input type="checkbox"/>	<input type="checkbox"/> <input type="checkbox"/> <input type="checkbox"/>	<input type="checkbox"/> <input type="checkbox"/>	<input type="checkbox"/> <input type="checkbox"/>	149.00#	1156	70	53	
48 x 72"	RXEEA4872	<input type="checkbox"/> <input type="checkbox"/> <input type="checkbox"/>	<input type="checkbox"/> <input type="checkbox"/> <input type="checkbox"/>	<input type="checkbox"/> <input type="checkbox"/>	<input type="checkbox"/> <input type="checkbox"/>	150.00#	1168	70	53	

A **B** **C** **D** **E**

HOW TO ORDER

- Indicate the following information on order form:
1. Quantity of each item.
 2. Model number, including options. See "How To Build a Model Number".
 3. Any special service required.

Note: • The indicates that a choice is required.
 • The absence of the indicates that no choice is required.
 • Alpha-numeric characters in place of indicate that no other alternatives are available.

HOW TO BUILD A MODEL NUMBER

- A** Select basic model/edge style.
74P - 1-1/4" laminate top w/74P edge band
- B** Select edge color.
 Refer to the **Product Color Options** page in this price list.
- C** Select surface finish.
 Refer to the **Product Color Options** page in this price list.
- D** Select base finish.
 Refer to the **Product Color Options** page in this price list.
- E** Select base option.
- | | |
|------------|------------------------|
| CCC | - Casters |
| BCF | - Casters/felt glides |
| BCN | - Casters/nylon glides |
| GFT | - Felt glides |
| GNV | - Nylon glides |

FINISH INFORMATION

Additional Laminate Offering

KI offers laminates beyond those offered in the standard offering. Laminates that are currently available in the program can be viewed in KI product specification tools. Requests to add laminates to the program can be submitted via the product modification request process. Please note, requests to add laminates to the program must include the laminate manufacturer's name, color/pattern number, and finish code. Edge options are limited to standard edge colors. If a matching edge is required, this will need to be requested through the product modification request process and may be subject to additional costs. Due to varying manufacturing processes and quality issues with some laminates, some requests may be denied. Extended lead times and minimum order quantities may apply on orders containing special laminates. Contact the product modification team for questions or additional information regarding special laminates and pricing.

SPECIAL SERVICES

Special Carton Marking

With specially marked information N/C

Shipping

Ships **knocked down, FOB Bonduel, WI 54107, freight prepaid.** Freight class 70.

Specifications and prices are subject to change without prior notice.

Ruckus® Activity Table (Delivered Pricing)

1-1/4" Top - 74P Edge



Ruckus® Activity Table (Delivered Pricing)

1-1/4" Top - 74P Edge

MODEL	A x B	MODEL NUMBER					Approx. Packaged Weight	Delivered Pricing	Chrome Upcharge add to list price	Laminate Grade 2 add to list price
		Basic Model/Edge Style	Edge Color	Surface Finish	Base Finish	Base Option				
Sit Height Adjustable Rectangle Square Corners Table, 20 to 33" H • Casters and glides are interchangeable • Tables are designed for maximum leg spacing • All corners of surface are squared • Specify casters/glides to wheelbarrow • Legs adjust with screws in 1" increments • Legs are factory pre-set at 29"H • 42x72, 44x72 and 48x72 have a center leg	20 x 48"	RXEEA2048	<input type="checkbox"/> <input type="checkbox"/> <input type="checkbox"/>	<input type="checkbox"/> <input type="checkbox"/> <input type="checkbox"/>	<input type="checkbox"/> <input type="checkbox"/>	<input type="checkbox"/> <input type="checkbox"/>	70.00#	\$ 672	\$ 77	\$ 19
	20 x 54"	RXEEA2054	<input type="checkbox"/> <input type="checkbox"/> <input type="checkbox"/>	<input type="checkbox"/> <input type="checkbox"/> <input type="checkbox"/>	<input type="checkbox"/> <input type="checkbox"/>	<input type="checkbox"/> <input type="checkbox"/>	74.00#	696	77	19
	20 x 60"	RXEEA2060	<input type="checkbox"/> <input type="checkbox"/> <input type="checkbox"/>	<input type="checkbox"/> <input type="checkbox"/> <input type="checkbox"/>	<input type="checkbox"/> <input type="checkbox"/>	<input type="checkbox"/> <input type="checkbox"/>	79.00#	699	77	19
	20 x 66"	RXEEA2066	<input type="checkbox"/> <input type="checkbox"/> <input type="checkbox"/>	<input type="checkbox"/> <input type="checkbox"/> <input type="checkbox"/>	<input type="checkbox"/> <input type="checkbox"/>	<input type="checkbox"/> <input type="checkbox"/>	84.00#	708	77	19
	20 x 72"	RXEEA2072	<input type="checkbox"/> <input type="checkbox"/> <input type="checkbox"/>	<input type="checkbox"/> <input type="checkbox"/> <input type="checkbox"/>	<input type="checkbox"/> <input type="checkbox"/>	<input type="checkbox"/> <input type="checkbox"/>	87.00#	716	77	19
	24 x 30"	RXEEA2430	<input type="checkbox"/> <input type="checkbox"/> <input type="checkbox"/>	<input type="checkbox"/> <input type="checkbox"/> <input type="checkbox"/>	<input type="checkbox"/> <input type="checkbox"/>	<input type="checkbox"/> <input type="checkbox"/>	62.00#	666	77	19
	24 x 36"	RXEEA2436	<input type="checkbox"/> <input type="checkbox"/> <input type="checkbox"/>	<input type="checkbox"/> <input type="checkbox"/> <input type="checkbox"/>	<input type="checkbox"/> <input type="checkbox"/>	<input type="checkbox"/> <input type="checkbox"/>	67.00#	679	77	19
	24 x 48"	RXEEA2448	<input type="checkbox"/> <input type="checkbox"/> <input type="checkbox"/>	<input type="checkbox"/> <input type="checkbox"/> <input type="checkbox"/>	<input type="checkbox"/> <input type="checkbox"/>	<input type="checkbox"/> <input type="checkbox"/>	77.00#	691	77	19
	24 x 54"	RXEEA2454	<input type="checkbox"/> <input type="checkbox"/> <input type="checkbox"/>	<input type="checkbox"/> <input type="checkbox"/> <input type="checkbox"/>	<input type="checkbox"/> <input type="checkbox"/>	<input type="checkbox"/> <input type="checkbox"/>	82.00#	696	77	27
	24 x 60"	RXEEA2460	<input type="checkbox"/> <input type="checkbox"/> <input type="checkbox"/>	<input type="checkbox"/> <input type="checkbox"/> <input type="checkbox"/>	<input type="checkbox"/> <input type="checkbox"/>	<input type="checkbox"/> <input type="checkbox"/>	87.00#	699	77	27
	24 x 66"	RXEEA2466	<input type="checkbox"/> <input type="checkbox"/> <input type="checkbox"/>	<input type="checkbox"/> <input type="checkbox"/> <input type="checkbox"/>	<input type="checkbox"/> <input type="checkbox"/>	<input type="checkbox"/> <input type="checkbox"/>	93.00#	708	77	27
	24 x 72"	RXEEA2472	<input type="checkbox"/> <input type="checkbox"/> <input type="checkbox"/>	<input type="checkbox"/> <input type="checkbox"/> <input type="checkbox"/>	<input type="checkbox"/> <input type="checkbox"/>	<input type="checkbox"/> <input type="checkbox"/>	97.00#	716	77	27
	30 x 48"	RXEEA3048	<input type="checkbox"/> <input type="checkbox"/> <input type="checkbox"/>	<input type="checkbox"/> <input type="checkbox"/> <input type="checkbox"/>	<input type="checkbox"/> <input type="checkbox"/>	<input type="checkbox"/> <input type="checkbox"/>	87.00#	724	77	27
	30 x 54"	RXEEA3054	<input type="checkbox"/> <input type="checkbox"/> <input type="checkbox"/>	<input type="checkbox"/> <input type="checkbox"/> <input type="checkbox"/>	<input type="checkbox"/> <input type="checkbox"/>	<input type="checkbox"/> <input type="checkbox"/>	93.00#	728	77	27
	30 x 60"	RXEEA3060	<input type="checkbox"/> <input type="checkbox"/> <input type="checkbox"/>	<input type="checkbox"/> <input type="checkbox"/> <input type="checkbox"/>	<input type="checkbox"/> <input type="checkbox"/>	<input type="checkbox"/> <input type="checkbox"/>	100.00#	731	77	27
	30 x 66"	RXEEA3066	<input type="checkbox"/> <input type="checkbox"/> <input type="checkbox"/>	<input type="checkbox"/> <input type="checkbox"/> <input type="checkbox"/>	<input type="checkbox"/> <input type="checkbox"/>	<input type="checkbox"/> <input type="checkbox"/>	107.00#	737	77	27
	30 x 72"	RXEEA3072	<input type="checkbox"/> <input type="checkbox"/> <input type="checkbox"/>	<input type="checkbox"/> <input type="checkbox"/> <input type="checkbox"/>	<input type="checkbox"/> <input type="checkbox"/>	<input type="checkbox"/> <input type="checkbox"/>	112.00#	757	77	27
	36 x 54"	RXEEA3654	<input type="checkbox"/> <input type="checkbox"/> <input type="checkbox"/>	<input type="checkbox"/> <input type="checkbox"/> <input type="checkbox"/>	<input type="checkbox"/> <input type="checkbox"/>	<input type="checkbox"/> <input type="checkbox"/>	105.00#	913	77	53
	36 x 60"	RXEEA3660	<input type="checkbox"/> <input type="checkbox"/> <input type="checkbox"/>	<input type="checkbox"/> <input type="checkbox"/> <input type="checkbox"/>	<input type="checkbox"/> <input type="checkbox"/>	<input type="checkbox"/> <input type="checkbox"/>	112.00#	915	77	53
	36 x 66"	RXEEA3666	<input type="checkbox"/> <input type="checkbox"/> <input type="checkbox"/>	<input type="checkbox"/> <input type="checkbox"/> <input type="checkbox"/>	<input type="checkbox"/> <input type="checkbox"/>	<input type="checkbox"/> <input type="checkbox"/>	119.00#	921	77	53
	36 x 72"	RXEEA3672	<input type="checkbox"/> <input type="checkbox"/> <input type="checkbox"/>	<input type="checkbox"/> <input type="checkbox"/> <input type="checkbox"/>	<input type="checkbox"/> <input type="checkbox"/>	<input type="checkbox"/> <input type="checkbox"/>	127.00#	928	77	53
	42 x 60"	RXEEA4260	<input type="checkbox"/> <input type="checkbox"/> <input type="checkbox"/>	<input type="checkbox"/> <input type="checkbox"/> <input type="checkbox"/>	<input type="checkbox"/> <input type="checkbox"/>	<input type="checkbox"/> <input type="checkbox"/>	125.00#	930	77	53
	42 x 66"	RXEEA4266	<input type="checkbox"/> <input type="checkbox"/> <input type="checkbox"/>	<input type="checkbox"/> <input type="checkbox"/> <input type="checkbox"/>	<input type="checkbox"/> <input type="checkbox"/>	<input type="checkbox"/> <input type="checkbox"/>	131.00#	933	77	53
	42 x 72"	RXEEA4272	<input type="checkbox"/> <input type="checkbox"/> <input type="checkbox"/>	<input type="checkbox"/> <input type="checkbox"/> <input type="checkbox"/>	<input type="checkbox"/> <input type="checkbox"/>	<input type="checkbox"/> <input type="checkbox"/>	142.00#	941	77	53
	44 x 60"	RXEEA4460	<input type="checkbox"/> <input type="checkbox"/> <input type="checkbox"/>	<input type="checkbox"/> <input type="checkbox"/> <input type="checkbox"/>	<input type="checkbox"/> <input type="checkbox"/>	<input type="checkbox"/> <input type="checkbox"/>	129.00#	1105	77	53
	44 x 66"	RXEEA4466	<input type="checkbox"/> <input type="checkbox"/> <input type="checkbox"/>	<input type="checkbox"/> <input type="checkbox"/> <input type="checkbox"/>	<input type="checkbox"/> <input type="checkbox"/>	<input type="checkbox"/> <input type="checkbox"/>	141.00#	1111	77	53
	44 x 72"	RXEEA4472	<input type="checkbox"/> <input type="checkbox"/> <input type="checkbox"/>	<input type="checkbox"/> <input type="checkbox"/> <input type="checkbox"/>	<input type="checkbox"/> <input type="checkbox"/>	<input type="checkbox"/> <input type="checkbox"/>	147.00#	1125	77	53
	48 x 60"	RXEEA4860	<input type="checkbox"/> <input type="checkbox"/> <input type="checkbox"/>	<input type="checkbox"/> <input type="checkbox"/> <input type="checkbox"/>	<input type="checkbox"/> <input type="checkbox"/>	<input type="checkbox"/> <input type="checkbox"/>	139.00#	1181	77	53
48 x 66"	RXEEA4866	<input type="checkbox"/> <input type="checkbox"/> <input type="checkbox"/>	<input type="checkbox"/> <input type="checkbox"/> <input type="checkbox"/>	<input type="checkbox"/> <input type="checkbox"/>	<input type="checkbox"/> <input type="checkbox"/>	151.00#	1193	77	53	
48 x 72"	RXEEA4872	<input type="checkbox"/> <input type="checkbox"/> <input type="checkbox"/>	<input type="checkbox"/> <input type="checkbox"/> <input type="checkbox"/>	<input type="checkbox"/> <input type="checkbox"/>	<input type="checkbox"/> <input type="checkbox"/>	152.00#	1205	77	53	

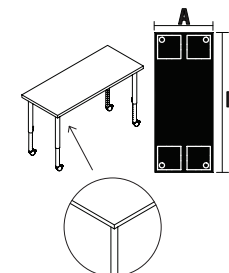

RXEEA

A **B** **C** **D** **E**

HOW TO ORDER

- Indicate the following information on order form:
- Quantity of each item.
 - Model number, including options. See "How To Build a Model Number".
 - Any special service required.

Note: • The indicates that a choice is required.
 • The absence of the indicates that no choice is required.
 • Alpha-numeric characters in place of indicate that no other alternatives are available.

HOW TO BUILD A MODEL NUMBER

- A** Select basic model/edge style.
74P - 1-1/4" laminate top w/74P edge band
- B** Select edge color.
 Refer to the **Product Color Options** page in this price list.
- C** Select surface finish.
 Refer to the **Product Color Options** page in this price list.
- D** Select base finish.
 Refer to the **Product Color Options** page in this price list.
- E** Select base option.
- | | |
|------------|------------------------|
| CCC | - Casters |
| BCF | - Casters/felt glides |
| BCN | - Casters/nylon glides |
| GFT | - Felt glides |
| GNV | - Nylon glides |

FINISH INFORMATION

Additional Laminate Offering
 KI offers laminates beyond those offered in the standard offering. Laminates that are currently available in the program can be viewed in KI product specification tools. Requests to add laminates to the program can be submitted via the product modification request process. Please note, requests to add laminates to the program must include the laminate manufacturer's name, color/pattern number, and finish code. Edge options are limited to standard edge colors. If a matching edge is required, this will need to be requested through the product modification request process and may be subject to additional costs. Due to varying manufacturing processes and quality issues with some laminates, some requests may be denied. Extended lead times and minimum order quantities may apply on orders containing special laminates. Contact the product modification team for questions or additional information regarding special laminates and pricing.

SPECIAL SERVICES

Special Carton Marking
 With specially marked information N/C

Shipping
 Ships **knocked down, FOB Bonduel, WI 54107, freight prepaid.** Freight class 70.

Specifications and prices are subject to change without prior notice.

Ruckus® Activity Table (Delivered Pricing)

1-1/4" Top - 74P Edge



Ruckus® Activity Table (Delivered Pricing)

1-1/4" Top - 74P Edge

MODEL	A x B	MODEL NUMBER					Approx. Packaged Weight	Delivered Pricing	Chrome Upcharge add to list price	Laminate Grade 2 add to list price
		Basic Model/Edge Style	Edge Color	Surface Finish	Base Finish	Base Option				
Sit-Stand Height Adjustable Rectangular Squared Corners Table, 29 to 42" H • Casters and glides are interchangeable • Tables are designed for maximum leg spacing • All corners of surface are squared • Specify casters/glides to wheelbarrow • Legs adjust with screws in 1" increments • Legs are factory pre-set at 29"H • 42x72, 44x72 and 48x72 have a center leg	20 x 48"	RXEFA2048	<input type="checkbox"/>	<input type="checkbox"/>	74.00#	\$ 751	\$ 88	\$ 19		
	20 x 54"	RXEFA2054	<input type="checkbox"/>	<input type="checkbox"/>	78.00#	760	88	19		
	20 x 60"	RXEFA2060	<input type="checkbox"/>	<input type="checkbox"/>	83.00#	762	88	19		
	20 x 66"	RXEFA2066	<input type="checkbox"/>	<input type="checkbox"/>	88.00#	766	88	19		
	20 x 72"	RXEFA2072	<input type="checkbox"/>	<input type="checkbox"/>	91.00#	773	88	19		
	24 x 30"	RXEFA2430	<input type="checkbox"/>	<input type="checkbox"/>	66.00#	719	88	19		
	24 x 36"	RXEFA2436	<input type="checkbox"/>	<input type="checkbox"/>	71.00#	732	88	19		
	24 x 48"	RXEFA2448	<input type="checkbox"/>	<input type="checkbox"/>	81.00#	754	88	19		
	24 x 54"	RXEFA2454	<input type="checkbox"/>	<input type="checkbox"/>	86.00#	762	88	27		
	24 x 60"	RXEFA2460	<input type="checkbox"/>	<input type="checkbox"/>	91.00#	765	88	27		
	24 x 66"	RXEFA2466	<input type="checkbox"/>	<input type="checkbox"/>	97.00#	768	88	27		
	24 x 72"	RXEFA2472	<input type="checkbox"/>	<input type="checkbox"/>	101.00#	775	88	27		
	30 x 48"	RXEFA3048	<input type="checkbox"/>	<input type="checkbox"/>	91.00#	786	88	27		
	30 x 54"	RXEFA3054	<input type="checkbox"/>	<input type="checkbox"/>	97.00#	791	88	27		
	30 x 60"	RXEFA3060	<input type="checkbox"/>	<input type="checkbox"/>	104.00#	794	88	27		
	30 x 66"	RXEFA3066	<input type="checkbox"/>	<input type="checkbox"/>	111.00#	806	88	27		
	30 x 72"	RXEFA3072	<input type="checkbox"/>	<input type="checkbox"/>	116.00#	813	88	27		
	36 x 54"	RXEFA3654	<input type="checkbox"/>	<input type="checkbox"/>	109.00#	993	88	53		
	36 x 60"	RXEFA3660	<input type="checkbox"/>	<input type="checkbox"/>	116.00#	954	88	53		
	36 x 66"	RXEFA3666	<input type="checkbox"/>	<input type="checkbox"/>	123.00#	960	88	53		
	36 x 72"	RXEFA3672	<input type="checkbox"/>	<input type="checkbox"/>	131.00#	966	88	53		
	42 x 60"	RXEFA4260	<input type="checkbox"/>	<input type="checkbox"/>	129.00#	991	88	53		
	42 x 66"	RXEFA4266	<input type="checkbox"/>	<input type="checkbox"/>	135.00#	993	88	53		
	42 x 72"	RXEFA4272	<input type="checkbox"/>	<input type="checkbox"/>	146.00#	1001	88	53		
44 x 60"	RXEFA4460	<input type="checkbox"/>	<input type="checkbox"/>	133.00#	1186	88	53			
44 x 66"	RXEFA4466	<input type="checkbox"/>	<input type="checkbox"/>	145.00#	1188	88	53			
44 x 72"	RXEFA4472	<input type="checkbox"/>	<input type="checkbox"/>	151.00#	1191	88	53			
48 x 60"	RXEFA4860	<input type="checkbox"/>	<input type="checkbox"/>	143.00#	1240	88	53			
48 x 66"	RXEFA4866	<input type="checkbox"/>	<input type="checkbox"/>	155.00#	1253	88	53			
48 x 72"	RXEFA4872	<input type="checkbox"/>	<input type="checkbox"/>	156.00#	1265	88	53			

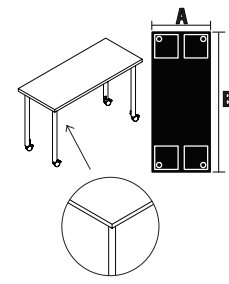

RXEFA

A **B** **C** **D** **E**

HOW TO ORDER

- Indicate the following information on order form:
- Quantity of each item.
 - Model number, including options. See "How To Build a Model Number".
 - Any special service required.

Note: • The indicates that a choice is required.
 • The absence of the indicates that no choice is required.
 • Alpha-numeric characters in place of indicate that no other alternatives are available.

HOW TO BUILD A MODEL NUMBER

- A** Select basic model/edge style.
74P - 1-1/4" laminate top w/74P edge band
- B** Select edge color.
 Refer to the **Product Color Options** page in this price list.
- C** Select surface finish.
 Refer to the **Product Color Options** page in this price list.
- D** Select base finish.
 Refer to the **Product Color Options** page in this price list.
- E** Select base option.
- | | |
|------------|------------------------|
| CCC | - Casters |
| BCF | - Casters/felt glides |
| BCN | - Casters/nylon glides |
| GFT | - Felt glides |
| GNV | - Nylon glides |

FINISH INFORMATION

Additional Laminate Offering
 KI offers laminates beyond those offered in the standard offering. Laminates that are currently available in the program can be viewed in KI product specification tools. Requests to add laminates to the program can be submitted via the product modification request process. Please note, requests to add laminates to the program must include the laminate manufacturer's name, color/pattern number, and finish code. Edge options are limited to standard edge colors. If a matching edge is required, this will need to be requested through the product modification request process and may be subject to additional costs. Due to varying manufacturing processes and quality issues with some laminates, some requests may be denied. Extended lead times and minimum order quantities may apply on orders containing special laminates. Contact the product modification team for questions or additional information regarding special laminates and pricing.

SPECIAL SERVICES

Special Carton Marking
 With specially marked information N/C

Shipping
 Ships **knocked down, FOB Bonduel, WI 54107, freight prepaid.** Freight class 70.

Specifications and prices are subject to change without prior notice.

Ruckus® Activity Table (Delivered Pricing)

1-1/4" Top - 74P Edge



Ruckus® Activity Table (Delivered Pricing)

1-1/4" Top - 74P Edge

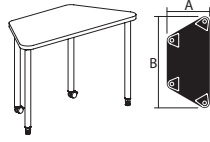
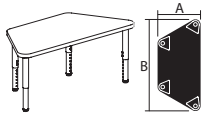
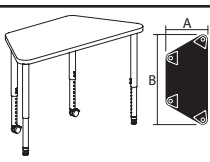
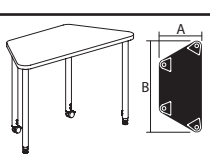
MODEL	A x B	MODEL NUMBER					Approx. Packaged Weight	Delivered Pricing	Chrome Upcharge add to list price	Laminate Grade 2 add to list price
		Basic Model/Edge Style	Edge Color	Surface Finish	Base Finish	Base Option				
 <p>Fixed Height Trapezoid Table, 29" H</p> <ul style="list-style-type: none"> • Casters and glides are interchangeable • Tables are designed for maximum leg spacing • All corners of surface are rounded • Specify casters/glides to wheelbarrow 	24 x 48"	RTEAM48-74P	<input type="checkbox"/>	<input type="checkbox"/>	51.00#	\$ 560	\$ 70	\$ 19		
	30 x 60"	RTEAM60-74P	<input type="checkbox"/>	<input type="checkbox"/>	65.00#	600	70	27		
RTEAM										
 <p>Floor Height Adjustable Trapezoid Table, 12 to 19" H</p> <ul style="list-style-type: none"> • Tables are designed for maximum leg spacing • All corners of surface are rounded • Legs adjust with screws in 1" increments • Legs are factory pre-set at 19"H • Base only available in glides 	24 x 48"	RTEHM48-74P	<input type="checkbox"/>	<input type="checkbox"/>	47.00#	\$ 627	\$ 75	\$ 19		
	30 x 60"	RTEHM60-74P	<input type="checkbox"/>	<input type="checkbox"/>	61.00#	667	75	27		
RTEHM										
 <p>Sit Height Adjustable Trapezoid Table, 20 to 33" H</p> <ul style="list-style-type: none"> • Casters and glides are interchangeable • Tables are designed for maximum leg spacing • All corners of surface are rounded • Specify casters/glides to wheelbarrow • Legs adjust with screws in 1" increments • Legs are factory pre-set at 29"H 	24 x 48"	RTEEM48-74P	<input type="checkbox"/>	<input type="checkbox"/>	53.00#	\$ 630	\$ 77	\$ 19		
	30 x 60"	RTEEM60-74P	<input type="checkbox"/>	<input type="checkbox"/>	65.00#	670	77	27		
RTEEM										
 <p>Sit-Stand Height Adjustable Trapezoid Table, 29 to 42" H</p> <ul style="list-style-type: none"> • Casters and glides are interchangeable • Tables are designed for maximum leg spacing • All corners of surface are rounded • Specify casters/glides to wheelbarrow • Legs adjust with screws in 1" increments • Legs are factory pre-set at 29"H 	24 x 48"	RTEFM48-74P	<input type="checkbox"/>	<input type="checkbox"/>	55.00#	\$ 652	\$ 88	\$ 19		
	30 x 60"	RTEFM60-74P	<input type="checkbox"/>	<input type="checkbox"/>	70.00#	692	88	27		
RTEFM										

A **B** **C** **D** **E**

HOW TO ORDER

- Indicate the following information on order form:
- Quantity of each item.
 - Model number, including options. See "How To Build a Model Number".
 - Any special service required.

Note: • The indicates that a choice is required.
 • The absence of the indicates that no choice is required.
 • Alpha-numeric characters in place of indicate that no other alternatives are available.

HOW TO BUILD A MODEL NUMBER

- A** Select basic model/edge style.
74P - 1-1/4" laminate top w/74P edge band
- B** Select edge color.
 Refer to the **Product Color Options** page in this price list.
- C** Select surface finish.
 Refer to the **Product Color Options** page in this price list.
- D** Select base finish.
 Refer to the **Product Color Options** page in this price list.
- E** Select base option.
CCC - Casters
BCF - Casters/felt glides
BCN - Casters/nylon glides
GFT - Felt glides
GNV - Nylon glides
 Base options for Floor Height Adjustable are

ONLY Felt glides - GFT and Nylon glides - GNV

FINISH INFORMATION

Additional Laminate Offering

KI offers laminates beyond those offered in the standard offering. Laminates that are currently available in the program can be viewed in KI product specification tools. Requests to add laminates to the program can be submitted via the product modification request process. Please note, requests to add laminates to the program must include the laminate manufacturer's name, color/pattern number, and finish code. Edge options are limited to standard edge colors. If a matching edge is required, this will need to be requested through the product modification request process and may be subject to additional costs. Due to varying manufacturing processes and quality issues with some laminates, some requests may be denied. Extended lead times and minimum order quantities may apply on orders containing special laminates. Contact the product modification team for questions or additional information regarding special laminates and pricing.

SPECIAL SERVICES

Special Carton Marking

With specially marked information N/C

Shipping
 Ships **knocked down, FOB Bonduel, WI 54107, freight prepaid.** Freight class 70.

Specifications and prices are subject to change without prior notice.

Ruckus® Activity Table (Delivered Pricing)

1-1/4" Top - 74P Edge



Ruckus® Activity Table (Delivered Pricing)

1-1/4" Top - 74P Edge

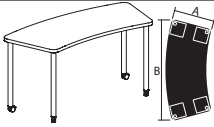
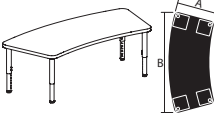
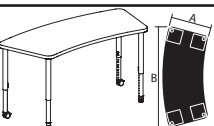
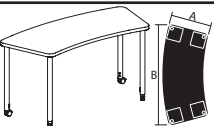
MODEL	A x B	MODEL NUMBER					Approx. Packaged Weight	Delivered Pricing	Chrome Upcharge add to list price	Laminate Grade 2 add to list price
		Basic Model/Edge Style	Edge Color	Surface Finish	Base Finish	Base Option				
 <p>Fixed Height Arc Table, 29" H</p> <ul style="list-style-type: none"> • Casters and glides are interchangeable • Tables are designed for maximum leg spacing • All corners of surface are rounded • Specify casters/glides to wheelbarrow 	24 x 59"	RTEAR24-74P	<input type="checkbox"/>	<input type="checkbox"/>	<input type="checkbox"/>	<input type="checkbox"/>	79.00#	\$ 720	\$ 88	\$ 27
RTEAR										
 <p>Floor Height Adjustable Arc Table, 12 to 19" H</p> <ul style="list-style-type: none"> • Tables are designed for maximum leg spacing • All corners of surface are rounded • Legs adjust with screws in 1" increments • Legs are factory pre-set at 19"H • Base only available in glides 	24 x 59"	RTEHR24-74P	<input type="checkbox"/>	<input type="checkbox"/>	<input type="checkbox"/>	<input type="checkbox"/>	76.00#	\$ 804	\$ 93	\$ 27
RTEHR										
 <p>Sit Height Adjustable Arc Table, 20 to 33" H</p> <ul style="list-style-type: none"> • Casters and glides are interchangeable • Tables are designed for maximum leg spacing • All corners of surface are rounded • Specify casters/glides to wheelbarrow • Legs adjust with screws in 1" increments • Legs are factory pre-set at 29"H 	24 x 59"	RTEER24-74P	<input type="checkbox"/>	<input type="checkbox"/>	<input type="checkbox"/>	<input type="checkbox"/>	81.00#	\$ 808	\$ 97	\$ 27
RTEER										
 <p>Sit-Stand Height Adjustable Arc Table, 29 to 42" H</p> <ul style="list-style-type: none"> • Casters and glides are interchangeable • Tables are designed for maximum leg spacing • All corners of surface are rounded • Specify casters/glides to wheelbarrow • Legs adjust with screws in 1" increments • Legs are factory pre-set at 29"H 	24 x 59"	RTEFR24-74P	<input type="checkbox"/>	<input type="checkbox"/>	<input type="checkbox"/>	<input type="checkbox"/>	85.00#	\$ 835	\$ 110	\$ 27
RTEFR										

A **B** **C** **D** **E**

HOW TO ORDER

- Indicate the following information on order form:
1. Quantity of each item.
 2. Model number, including options. See "How To Build a Model Number".
 3. Any special service required.

Note: • The indicates that a choice is required.
 • The absence of the indicates that no choice is required.
 • Alpha-numeric characters in place of indicate that no other alternatives are available.

HOW TO BUILD A MODEL NUMBER

- A** Select basic model/edge style.
74P - 1-1/4" laminate top w/74P edge band
- B** Select edge color.
 Refer to the **Product Color Options** page in this price list.
- C** Select surface finish.
 Refer to the **Product Color Options** page in this price list.
- D** Select base finish.
 Refer to the **Product Color Options** page in this price list.
- E** Select base option.
CCC - Casters
BCF - Casters/felt glides
BCN - Casters/nylon glides
GFT - Felt glides
GNV - Nylon glides
 Base options for Floor Height Adjustable are

ONLY Felt glides - GFT and Nylon glides - GNV

FINISH INFORMATION

Additional Laminate Offering

KI offers laminates beyond those offered in the standard offering. Laminates that are currently available in the program can be viewed in KI product specification tools. Requests to add laminates to the program can be submitted via the product modification request process. Please note, requests to add laminates to the program must include the laminate manufacturer's name, color/pattern number, and finish code. Edge options are limited to standard edge colors. If a matching edge is required, this will need to be requested through the product modification request process and may be subject to additional costs. Due to varying manufacturing processes and quality issues with some laminates, some requests may be denied. Extended lead times and minimum order quantities may apply on orders containing special laminates. Contact the product modification team for questions or additional information regarding special laminates and pricing.

SPECIAL SERVICES

Special Carton Marking

With specially marked information N/C

Shipping

Ships **knocked down, FOB Bonduel, WI 54107, freight prepaid**. Freight class 70.

Specifications and prices are subject to change without prior notice.

Ruckus® Activity Table (Delivered Pricing)

1-1/4" Top - 74P Edge



Ruckus® Activity Table (Delivered Pricing)

1-1/4" Top - 74P Edge

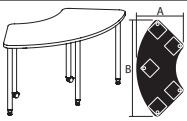
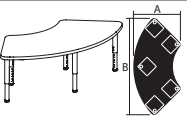
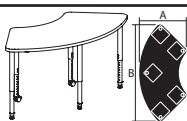
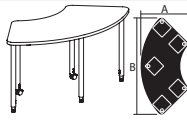
MODEL	A x B	MODEL NUMBER					Approx. Packaged Weight	Delivered Pricing	Chrome Upcharge add to list price	Laminate Grade 2 add to list price
		Basic Model/Edge Style	Edge Color	Surface Finish	Base Finish	Base Option				
 <p>Fixed Height Quarter Round Table, 29" H • Casters and glides are interchangeable • Tables are designed for maximum leg spacing • All corners of surface are rounded • Specify casters/glides to wheelbarrow</p>	24 x 65"	RTEAX24-74P	<input type="checkbox"/>	<input type="checkbox"/>	<input type="checkbox"/>	<input type="checkbox"/>	76.00#	\$ 805	\$ 70	\$ 27
RTEAX										
 <p>Floor Height Adjustable Quarter Round Table, 12 to 19" H • Tables are designed for maximum leg spacing • All corners of surface are rounded • Legs adjust with screws in 1" increments • Legs are factory pre-set at 19"H • Base only available in glides</p>	24 x 65"	RTEHX24-74P	<input type="checkbox"/>	<input type="checkbox"/>	<input type="checkbox"/>	<input type="checkbox"/>	71.00#	\$ 872	\$ 75	\$ 27
RTEHX										
 <p>Sit Height Adjustable Quarter Round Table, 20 to 33" H • Casters and glides are interchangeable • Tables are designed for maximum leg spacing • All corners of surface are rounded • Specify casters/glides to wheelbarrow • Legs adjust with screws in 1" increments • Legs are factory pre-set at 29"H</p>	24 x 65"	RTEEX24-74P	<input type="checkbox"/>	<input type="checkbox"/>	<input type="checkbox"/>	<input type="checkbox"/>	78.00#	\$ 875	\$ 77	\$ 27
RTEEX										
 <p>Sit-Stand Height Adjustable Quarter Round Table, 29 to 42" H • Casters and glides are interchangeable • Tables are designed for maximum leg spacing • All corners of surface are rounded • Specify casters/glides to wheelbarrow • Legs adjust with screws in 1" increments • Legs are factory pre-set at 29"H</p>	24 x 65"	RTEFX24-74P	<input type="checkbox"/>	<input type="checkbox"/>	<input type="checkbox"/>	<input type="checkbox"/>	84.00#	\$ 897	\$ 88	\$ 27
RTEFX										

A **B** **C** **D** **E**

HOW TO ORDER

- Indicate the following information on order form:
- Quantity of each item.
 - Model number, including options. See "How To Build a Model Number".
 - Any special service required.

Note: • The indicates that a choice is required.

- The absence of the indicates that no choice is required.
- Alpha-numeric characters in place of indicate that no other alternatives are available.

HOW TO BUILD A MODEL NUMBER

A Select basic model/edge style.
74P - 1-1/4" laminate top w/74P edge band

B Select edge color.
 Refer to the **Product Color Options** page in this price list.

C Select surface finish.
 Refer to the **Product Color Options** page in this price list.

D Select base finish.
 Refer to the **Product Color Options** page in this price list.

E Select base option.
CCC - Casters
BCF - Casters/felt glides
BCN - Casters/nylon glides
GFT - Felt glides
GNV - Nylon glides
 Base options for Floor Height Adjustable are

ONLY Felt glides - GFT and Nylon glides - GNV

FINISH INFORMATION

Additional Laminate Offering

KI offers laminates beyond those offered in the standard offering. Laminates that are currently available in the program can be viewed in KI product specification tools. Requests to add laminates to the program can be submitted via the product modification request process. Please note, requests to add laminates to the program must include the laminate manufacturer's name, color/pattern number, and finish code. Edge options are limited to standard edge colors. If a matching edge is required, this will need to be requested through the product modification request process and may be subject to additional costs. Due to varying manufacturing processes and quality issues with some laminates, some requests may be denied. Extended lead times and minimum order quantities may apply on orders containing special laminates. Contact the product modification team for questions or additional information regarding special laminates and pricing.

SPECIAL SERVICES

Special Carton Marking

With specially marked information N/C

Shipping

Ships **knocked down, FOB Bonduel, WI 54107, freight prepaid.** Freight class 70.

Specifications and prices are subject to change without prior notice.

Ruckus® Activity Table (Delivered Pricing)

1-1/4" Top - 74P Edge



Ruckus® Activity Table (Delivered Pricing)

1-1/4" Top - 74P Edge

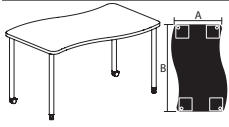
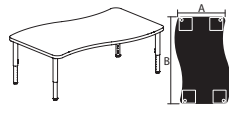
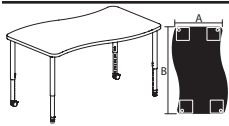
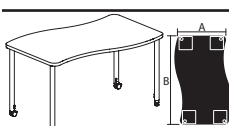
MODEL	A x B	MODEL NUMBER					Approx. Packaged Weight	Delivered Pricing	Chrome Upcharge add to list price	Laminate Grade 2 add to list price
		Basic Model/Edge Style	Edge Color	Surface Finish	Base Finish	Base Option				
 <p>Fixed Height Wave Table, 29" H</p> <ul style="list-style-type: none"> • Casters and glides are interchangeable • Tables are designed for maximum leg spacing • All corners of surface are rounded • Specify casters/glides to wheelbarrow • Pairs well with Yin Yang 	30 x 54"	RTEAW3054-74P	<input type="checkbox"/>	<input type="checkbox"/>	<input type="checkbox"/>	89.00#	\$ 740	\$ 70	\$ 27	
	30 x 60"	RTEAW3060-74P	<input type="checkbox"/>	<input type="checkbox"/>	<input type="checkbox"/>	96.00#	765	70	27	
 <p>Floor Height Adjustable Wave Table, 12 to 19" H</p> <ul style="list-style-type: none"> • Tables are designed for maximum leg spacing • All corners of surface are rounded • Legs adjust with screws in 1" increments • Legs are factory pre-set at 19"H • Base only available in glides • Pairs well with Yin Yang 	30 x 54"	RTEHW3054-74P	<input type="checkbox"/>	<input type="checkbox"/>	<input type="checkbox"/>	85.00#	\$ 807	\$ 75	\$ 27	
	30 x 60"	RTEHW3060-74P	<input type="checkbox"/>	<input type="checkbox"/>	<input type="checkbox"/>	90.00#	832	75	27	
 <p>Sit Height Adjustable Wave Table, 20 to 33" H</p> <ul style="list-style-type: none"> • Casters and glides are interchangeable • Tables are designed for maximum leg spacing • All corners of surface are rounded • Specify casters/glides to wheelbarrow • Legs adjust with screws in 1" increments • Legs are factory pre-set at 29"H • Pairs well with Yin Yang 	30 x 54"	RTEEW3054-74P	<input type="checkbox"/>	<input type="checkbox"/>	<input type="checkbox"/>	89.00#	\$ 810	\$ 77	\$ 27	
	30 x 60"	RTEEW3060-74P	<input type="checkbox"/>	<input type="checkbox"/>	<input type="checkbox"/>	97.00#	835	77	27	
 <p>Sit-Stand Height Adjustable Wave Table, 29 to 42" H</p> <ul style="list-style-type: none"> • Casters and glides are interchangeable • Tables are designed for maximum leg spacing • All corners of surface are rounded • Specify casters/glides to wheelbarrow • Legs adjust with screws in 1" increments • Legs are factory pre-set at 29"H • Pairs well with Yin Yang 	30 x 54"	RTEFW3054-74P	<input type="checkbox"/>	<input type="checkbox"/>	<input type="checkbox"/>	95.00#	\$ 832	\$ 88	\$ 27	
	30 x 60"	RTEFW3060-74P	<input type="checkbox"/>	<input type="checkbox"/>	<input type="checkbox"/>	102.00#	857	88	27	

A **B** **C** **D** **E**

HOW TO ORDER

- Indicate the following information on order form:
1. Quantity of each item.
 2. Model number, including options. See "How To Build a Model Number".
 3. Any special service required.

Note: • The indicates that a choice is required.

- The absence of the indicates that no choice is required.
- Alpha-numeric characters in place of indicate that no other alternatives are available.

HOW TO BUILD A MODEL NUMBER

A Select basic model/edge style.
74P - 1-1/4" laminate top w/74P edge band

B Select edge color.
 Refer to the **Product Color Options** page in this price list.

C Select surface finish.
 Refer to the **Product Color Options** page in this price list.

D Select base finish.
 Refer to the **Product Color Options** page in this price list.

E Select base option.
CCC - Casters
BCF - Casters/felt glides
BCN - Casters/nylon glides
GFT - Felt glides
GNV - Nylon glides
 Base options for Floor Height Adjustable are

ONLY Felt glides - GFT and Nylon glides - GNV

FINISH INFORMATION

Additional Laminate Offering

KI offers laminates beyond those offered in the standard offering. Laminates that are currently available in the program can be viewed in KI product specification tools. Requests to add laminates to the program can be submitted via the product modification request process. Please note, requests to add laminates to the program must include the laminate manufacturer's name, color/pattern number, and finish code. Edge options are limited to standard edge colors. If a matching edge is required, this will need to be requested through the product modification request process and may be subject to additional costs. Due to varying manufacturing processes and quality issues with some laminates, some requests may be denied. Extended lead times and minimum order quantities may apply on orders containing special laminates. Contact the product modification team for questions or additional information regarding special laminates and pricing.

SPECIAL SERVICES

Special Carton Marking

With specially marked information N/C

Shipping
 Ships **knocked down, FOB Bonduel, WI 54107, freight prepaid.** Freight class 70.

Specifications and prices are subject to change without prior notice.

Ruckus® Activity Table (Delivered Pricing)

1-1/4" Top - 74P Edge



Ruckus® Activity Table (Delivered Pricing)

1-1/4" Top - 74P Edge

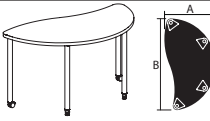
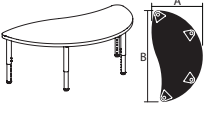
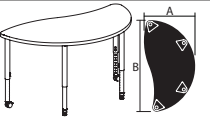
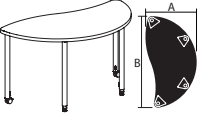
MODEL	A x B	MODEL NUMBER					Approx. Packaged Weight	Delivered Pricing	Chrome Upcharge add to list price	Laminate Grade 2 add to list price
		Basic Model/Edge Style	Edge Color	Surface Finish	Base Finish	Base Option				
 <p>Fixed Height Yin Yang Table, 29" H</p> <ul style="list-style-type: none"> • Casters and glides are interchangeable • Tables are designed for maximum leg spacing • All corners of surface are rounded • Specify casters/glides to wheelbarrow • Pairs well with like size Wave shaped table 	30 x 54"	RTEA054-74P	<input type="checkbox"/>	<input type="checkbox"/>	63.00#	\$ 640	\$ 70	\$ 53		
	30 x 60"	RTEA060-74P	<input type="checkbox"/>	<input type="checkbox"/>	73.00#	695	70	53		
 <p>Floor Height Adjustable Yin Yang Table, 12 to 19" H</p> <ul style="list-style-type: none"> • Tables are designed for maximum leg spacing • All corners of surface are rounded • Legs adjust with screws in 1" increments • Legs are factory pre-set at 19"H • Base only available in glides • Pairs well with like size Wave shaped table 	30 x 54"	RTEH054-74P	<input type="checkbox"/>	<input type="checkbox"/>	57.00#	\$ 707	\$ 75	\$ 53		
	30 x 60"	RTEH060-74P	<input type="checkbox"/>	<input type="checkbox"/>	74.00#	762	75	53		
 <p>Sit Height Adjustable Yin Yang Table, 20 to 33" H</p> <ul style="list-style-type: none"> • Casters and glides are interchangeable • Tables are designed for maximum leg spacing • All corners of surface are rounded • Specify casters/glides to wheelbarrow • Legs adjust with screws in 1" increments • Legs are factory pre-set at 29"H • Pairs well with like size Wave shaped table 	30 x 54"	RTEE054-74P	<input type="checkbox"/>	<input type="checkbox"/>	65.00#	\$ 710	\$ 77	\$ 53		
	30 x 60"	RTEE060-74P	<input type="checkbox"/>	<input type="checkbox"/>	73.00#	765	77	53		
 <p>Sit-Stand Height Adjustable Yin Yang Table, 29 to 42" H</p> <ul style="list-style-type: none"> • Casters and glides are interchangeable • Tables are designed for maximum leg spacing • All corners of surface are rounded • Specify casters/glides to wheelbarrow • Legs adjust with screws in 1" increments • Legs are factory pre-set at 29"H • Pairs well with like size Wave shaped table 	30 x 54"	RTEF054-74P	<input type="checkbox"/>	<input type="checkbox"/>	69.00#	\$ 732	\$ 88	\$ 53		
	30 x 60"	RTEF060-74P	<input type="checkbox"/>	<input type="checkbox"/>	74.00#	787	88	53		

A B C D E

HOW TO ORDER

- Indicate the following information on order form:
- Quantity of each item.
 - Model number, including options. See "How To Build a Model Number".
 - Any special service required.

Note: • The indicates that a choice is required.
 • The absence of the indicates that no choice is required.
 • Alpha-numeric characters in place of indicate that no other alternatives are available.

HOW TO BUILD A MODEL NUMBER

- A** Select basic model/edge style.
74P - 1-1/4" laminate top w/74P edge band
- B** Select edge color.
 Refer to the **Product Color Options** page in this price list.
- C** Select surface finish.
 Refer to the **Product Color Options** page in this price list.
- D** Select base finish.
 Refer to the **Product Color Options** page in this price list.
- E** Select base option.
CCC - Casters
BCF - Casters/felt glides
BCN - Casters/nylon glides
GFT - Felt glides
GNV - Nylon glides
 Base options for Floor Height Adjustable are

ONLY Felt glides - GFT and Nylon glides - GNV

FINISH INFORMATION

Additional Laminate Offering

KI offers laminates beyond those offered in the standard offering. Laminates that are currently available in the program can be viewed in KI product specification tools. Requests to add laminates to the program can be submitted via the product modification request process. Please note, requests to add laminates to the program must include the laminate manufacturer's name, color/pattern number, and finish code. Edge options are limited to standard edge colors. If a matching edge is required, this will need to be requested through the product modification request process and may be subject to additional costs. Due to varying manufacturing processes and quality issues with some laminates, some requests may be denied. Extended lead times and minimum order quantities may apply on orders containing special laminates. Contact the product modification team for questions or additional information regarding special laminates and pricing.

SPECIAL SERVICES

Special Carton Marking

With specially marked information N/C

Shipping
 Ships **knocked down, FOB Bonduel, WI 54107, freight prepaid.** Freight class 70.

Specifications and prices are subject to change without prior notice.

Ruckus® Activity Table (Delivered Pricing)

1-1/4" Top - 74P Edge



Ruckus® Activity Table (Delivered Pricing)

1-1/4" Top - 74P Edge

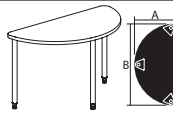
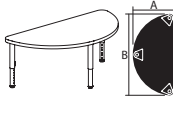
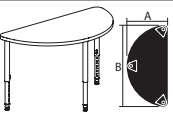
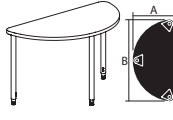
MODEL	A x B	MODEL NUMBER					Approx. Packaged Weight	Delivered Pricing	Chrome Upcharge add to list price	Laminate Grade 2 add to list price
		Basic Model/Edge Style	Edge Color	Surface Finish	Base Finish	Base Option				
 RTEAQ Fixed Height Half Round Table, 29" H • Casters and glides are interchangeable • Tables are designed for maximum leg spacing • All corners of surface are rounded • Specify casters/glides to wheelbarrow • 48" tables have 3 legs; 60" tables have 4 legs	24 x 48"	RTEAQ48-74P	<input type="checkbox"/>	<input type="checkbox"/>	<input type="checkbox"/>	<input type="checkbox"/>	50.00#	\$ 500	\$ 51	\$ 19
	30 x 60"	RTEAQ60-74P	<input type="checkbox"/>	<input type="checkbox"/>	<input type="checkbox"/>	<input type="checkbox"/>	72.00#	655	70	27
 RTEHQ Floor Height Adjustable Half Round Table, 12 to 19" H • Tables are designed for maximum leg spacing • All corners of surface are rounded • Legs adjust with screws in 1" increments • Legs are factory pre-set at 19"H • Base only available in glides • 48" tables have 3 legs; 60" tables have 4 legs	24 x 48"	RTEHQ48-74P	<input type="checkbox"/>	<input type="checkbox"/>	<input type="checkbox"/>	<input type="checkbox"/>	47.00#	\$ 550	\$ 54	\$ 19
	30 x 60"	RTEHQ60-74P	<input type="checkbox"/>	<input type="checkbox"/>	<input type="checkbox"/>	<input type="checkbox"/>	68.00#	722	75	27
 RTEEQ Sit Height Adjustable Half Round Table, 20 to 33" H • Casters and glides are interchangeable • Tables are designed for maximum leg spacing • All corners of surface are rounded • Specify casters/glides to wheelbarrow • Legs adjust with screws in 1" increments • Legs are factory pre-set at 29"H • 48" tables have 3 legs; 60" tables have 4 legs	24 x 48"	RTEEQ48-74P	<input type="checkbox"/>	<input type="checkbox"/>	<input type="checkbox"/>	<input type="checkbox"/>	51.00#	\$ 553	\$ 56	\$ 19
	30 x 60"	RTEEQ60-74P	<input type="checkbox"/>	<input type="checkbox"/>	<input type="checkbox"/>	<input type="checkbox"/>	81.00#	725	77	27
 RTEFQ Sit-Stand Height Adjustable Half Round Table, 29 to 42" H • Casters and glides are interchangeable • Tables are designed for maximum leg spacing • All corners of surface are rounded • Specify casters/glides to wheelbarrow • Legs adjust with screws in 1" increments • Legs are factory pre-set at 29"H • 48" tables have 3 legs; 60" tables have 4 legs	24 x 48"	RTEFQ48-74P	<input type="checkbox"/>	<input type="checkbox"/>	<input type="checkbox"/>	<input type="checkbox"/>	55.00#	\$ 569	\$ 65	\$ 19
	30 x 60"	RTEFQ60-74P	<input type="checkbox"/>	<input type="checkbox"/>	<input type="checkbox"/>	<input type="checkbox"/>	78.00#	757	88	27

A **B** **C** **D** **E**

HOW TO ORDER

- Indicate the following information on order form:
- Quantity of each item.
 - Model number, including options. See "How To Build a Model Number".
 - Any special service required.

Note: • The indicates that a choice is required.

- The absence of the indicates that no choice is required.
- Alpha-numeric characters in place of indicate that no other alternatives are available.

HOW TO BUILD A MODEL NUMBER

- A** Select basic model/edge style.
74P - 1-1/4" laminate top w/74P edge band
- B** Select edge color.
 Refer to the **Product Color Options** page in this price list.
- C** Select surface finish.
 Refer to the **Product Color Options** page in this price list.
- D** Select base finish.
 Refer to the **Product Color Options** page in this price list.
- E** Select base option.
BCF - Casters/felt glides
BCN - Casters/nylon glides
GFT - Felt glides
GNY - Nylon glides
CCC - Casters
 Base options for Floor Height Adjustable and

48" half round tables are ONLY Felt glides - GFT and Nylon glides - GNY

FINISH INFORMATION

Additional Laminate Offering

KI offers laminates beyond those offered in the standard offering. Laminates that are currently available in the program can be viewed in KI product specification tools. Requests to add laminates to the program can be submitted via the product modification request process. Please note, requests to add laminates to the program must include the laminate manufacturer's name, color/pattern number, and finish code. Edge options are limited to standard edge colors. If a matching edge is required, this will need to be requested through the product modification request process and may be subject to additional costs. Due to varying manufacturing processes and quality issues with some laminates, some requests may be denied. Extended lead times and minimum order quantities may apply on orders containing special laminates. Contact the product modification team for questions or additional information regarding special laminates and pricing.

SPECIAL SERVICES

Special Carton Marking

With specially marked information N/C

Shipping

Ships **knocked down, FOB Bonduel, WI 54107, freight prepaid.** Freight class 70.

Specifications and prices are subject to change without prior notice.

Ruckus® Activity Table (Delivered Pricing)

1-1/4" Top - 74P Edge



Ruckus® Activity Table (Delivered Pricing)

1-1/4" Top - 74P Edge

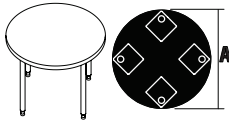
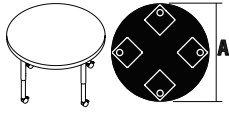
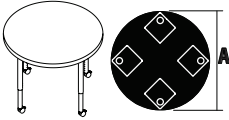
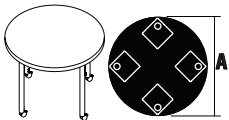
MODEL	A	MODEL NUMBER					Approx. Packaged Weight	Delivered Pricing	Chrome Upcharge add to list price	Laminate Grade 2 add to list price
		Basic Model/Edge Style	Edge Color	Surface Finish	Base Finish	Base Option				
 <p>Fixed Height Round Table, 29" H</p> <ul style="list-style-type: none"> • Casters and glides are interchangeable • Tables are designed for maximum leg spacing • Specify casters/glides to wheelbarrow 	36"	RTEAB36	<input type="checkbox"/>	<input type="checkbox"/>	<input type="checkbox"/>	<input type="checkbox"/>	69.00#	\$ 661	\$ 70	\$ 37
	42"	RTEAB42	<input type="checkbox"/>	<input type="checkbox"/>	<input type="checkbox"/>	<input type="checkbox"/>	82.00#	762	70	37
	48"	RTEAB48	<input type="checkbox"/>	<input type="checkbox"/>	<input type="checkbox"/>	<input type="checkbox"/>	97.00#	841	70	37
	60"	RTEAB60	<input type="checkbox"/>	<input type="checkbox"/>	<input type="checkbox"/>	<input type="checkbox"/>	132.00#	1010	70	53
RTEAB										
 <p>Floor Height Adjustable Round Table, 12 to 19" H</p> <ul style="list-style-type: none"> • Tables are designed for maximum leg spacing • Base only available in glides • Legs adjust with screws in 1" increments • Legs are factory pre-set at 19"H 	36"	RTEHB36	<input type="checkbox"/>	<input type="checkbox"/>	<input type="checkbox"/>	<input type="checkbox"/>	66.50#	\$ 749	\$ 75	\$ 37
	42"	RTEHB42	<input type="checkbox"/>	<input type="checkbox"/>	<input type="checkbox"/>	<input type="checkbox"/>	79.50#	853	75	37
	48"	RTEHB48	<input type="checkbox"/>	<input type="checkbox"/>	<input type="checkbox"/>	<input type="checkbox"/>	94.50#	934	75	37
	60"	RTEHB60	<input type="checkbox"/>	<input type="checkbox"/>	<input type="checkbox"/>	<input type="checkbox"/>	129.50#	1111	75	53
RTEHB										
 <p>Sit Height Adjustable Round Table, 20 to 33" H</p> <ul style="list-style-type: none"> • Casters and glides are interchangeable • Tables are designed for maximum leg spacing • Specify casters/glides to wheelbarrow • Legs adjust with screws in 1" increments • Legs are factory pre-set at 29"H 	36"	RTEEB36	<input type="checkbox"/>	<input type="checkbox"/>	<input type="checkbox"/>	<input type="checkbox"/>	71.00#	\$ 739	\$ 77	\$ 37
	42"	RTEEB42	<input type="checkbox"/>	<input type="checkbox"/>	<input type="checkbox"/>	<input type="checkbox"/>	84.00#	841	77	37
	48"	RTEEB48	<input type="checkbox"/>	<input type="checkbox"/>	<input type="checkbox"/>	<input type="checkbox"/>	99.00#	922	77	37
	60"	RTEEB60	<input type="checkbox"/>	<input type="checkbox"/>	<input type="checkbox"/>	<input type="checkbox"/>	134.00#	1094	77	53
RTEEB										
 <p>Sit-Stand Height Adjustable Round Table, 29 to 42" H</p> <ul style="list-style-type: none"> • Casters and glides are interchangeable • Tables are designed for maximum leg spacing • Specify casters/glides to wheelbarrow • Legs adjust with screws in 1" increments • Legs are factory pre-set at 29"H 	36"	RTEFB36	<input type="checkbox"/>	<input type="checkbox"/>	<input type="checkbox"/>	<input type="checkbox"/>	75.00#	\$ 892	\$ 88	\$ 37
	42"	RTEFB42	<input type="checkbox"/>	<input type="checkbox"/>	<input type="checkbox"/>	<input type="checkbox"/>	88.00#	860	88	37
	48"	RTEFB48	<input type="checkbox"/>	<input type="checkbox"/>	<input type="checkbox"/>	<input type="checkbox"/>	103.00#	941	88	37
	60"	RTEFB60	<input type="checkbox"/>	<input type="checkbox"/>	<input type="checkbox"/>	<input type="checkbox"/>	138.00#	1113	88	53
RTEFB										

A B C D E

HOW TO ORDER

- Indicate the following information on order form:
1. Quantity of each item.
 2. Model number, including options. See "How To Build a Model Number".
 3. Any special service required.

Note: • The indicates that a choice is required.

- The absence of the indicates that no choice is required.
- Alpha-numeric characters in place of indicate that no other alternatives are available.

HOW TO BUILD A MODEL NUMBER

Felt glides - GFT and Nylon glides - GNY

- A** Select basic model/edge style.
74P - 1-1/4" laminate top w/74P edge band
- B** Select edge color.
 Refer to the **Product Color Options** page in this price list.
- C** Select surface finish.
 Refer to the **Product Color Options** page in this price list.
- D** Select base finish.
 Refer to the **Product Color Options** page in this price list.
- E** Select base option.
- CCC** - Casters
 - BCF** - Casters/felt glides
 - BCN** - Casters/nylon glides
 - GFT** - Felt glides
 - GNY** - Nylon glides
- Base options for Floor Activity Height are ONLY

FINISH INFORMATION

Additional Laminate Offering

KI offers laminates beyond those offered in the standard offering. Laminates that are currently available in the program can be viewed in KI product specification tools. Requests to add laminates to the program can be submitted via the product modification request process. Please note, requests to add laminates to the program must include the laminate manufacturer's name, color/pattern number, and finish code. Edge options are limited to standard edge colors. If a matching edge is required, this will need to be requested through the product modification request process and may be subject to additional costs. Due to varying manufacturing processes and quality issues with some laminates, some requests may be denied. Extended lead times and minimum order quantities may apply on orders containing special laminates. Contact the product modification team for questions or additional information regarding special laminates and pricing.

SPECIAL SERVICES

Special Carton Marking

With specially marked information N/C

Shipping

Ships **knocked down, FOB Bonduel, WI 54107, freight prepaid**. Freight class 70.

Specifications and prices are subject to change without prior notice.



Ruckus® Activity Table (Delivered Pricing)

1-1/4" Top - 74P Edge

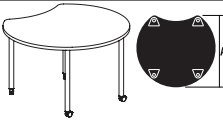

Ruckus® Activity Table (Delivered Pricing)

1-1/4" Top - 74P Edge

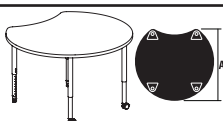
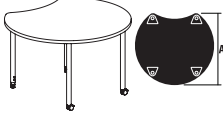
MODEL	A	MODEL NUMBER					Approx. Packaged Weight	Delivered Pricing	Chrome Upcharge add to list price	Laminate Grade 2 add to list price
		Basic Model/Edge Style	Edge Color	Surface Finish	Base Finish	Base Option				
 <p>Fixed Height Crescent Table, 29" H</p> <ul style="list-style-type: none"> • Casters and glides are interchangeable • Tables are designed for maximum leg spacing • All corners of surface are rounded • Specify casters/glides to wheelbarrow 	48"	RTEAT48-74P	<input type="checkbox"/>	<input type="checkbox"/>	<input type="checkbox"/>	<input type="checkbox"/>	79.00#	\$ 750	\$ 70	\$ 37
RTEAT										
 <p>Floor Height Adjustable Crescent Table, 12 to 19" H</p> <ul style="list-style-type: none"> • Tables are designed for maximum leg spacing • All corners of surface are rounded • Legs adjust with screws in 1" increments • Legs are factory pre-set at 19"H • Base only available in glides 	48"	RTEHT48-74P	<input type="checkbox"/>	<input type="checkbox"/>	<input type="checkbox"/>	<input type="checkbox"/>	76.00#	\$ 817	\$ 75	\$ 37
RTEHT										
 <p>Sit Height Adjustable Crescent Table, 20 to 33" H</p> <ul style="list-style-type: none"> • Casters and glides are interchangeable • Tables are designed for maximum leg spacing • All corners of surface are rounded • Specify casters/glides to wheelbarrow • Legs adjust with screws in 1" increments • Legs are factory pre-set at 29"H 	48"	RTEET48-74P	<input type="checkbox"/>	<input type="checkbox"/>	<input type="checkbox"/>	<input type="checkbox"/>	81.00#	\$ 820	\$ 77	\$ 37
RTEET										
 <p>Sit-Stand Height Adjustable Crescent Table, 29 to 42" H</p> <ul style="list-style-type: none"> • Casters and glides are interchangeable • Tables are designed for maximum leg spacing • All corners of surface are rounded • Specify casters/glides to wheelbarrow • Legs adjust with screws in 1" increments • Legs are factory pre-set at 29"H 	48"	RTEFT48-74P	<input type="checkbox"/>	<input type="checkbox"/>	<input type="checkbox"/>	<input type="checkbox"/>	86.00#	\$ 842	\$ 88	\$ 37
RTEFT										

A B C D E

HOW TO ORDER

- Indicate the following information on order form:
1. Quantity of each item.
 2. Model number, including options. See "How To Build a Model Number".
 3. Any special service required.

Note: • The indicates that a choice is required.
 • The absence of the indicates that no choice is required.
 • Alpha-numeric characters in place of indicate that no other alternatives are available.

HOW TO BUILD A MODEL NUMBER

- A** Select basic model/edge style.
74P - 1-1/4" laminate top w/74P edge band
- B** Select edge color.
 Refer to the **Product Color Options** page in this price list.
- C** Select surface finish.
 Refer to the **Product Color Options** page in this price list.
- D** Select base finish.
 Refer to the **Product Color Options** page in this price list.
- E** Select base option.
GFT - Felt glides
GNV - Nylon glides
CCC - Casters
BCF - Casters/felt glides
BCN - Casters/nylon glides
 Base options for Floor Height Adjustable are

ONLY Felt glides - GFT and Nylon glides - GNV

FINISH INFORMATION

Additional Laminate Offering

KI offers laminates beyond those offered in the standard offering. Laminates that are currently available in the program can be viewed in KI product specification tools. Requests to add laminates to the program can be submitted via the product modification request process. Please note, requests to add laminates to the program must include the laminate manufacturer's name, color/pattern number, and finish code. Edge options are limited to standard edge colors. If a matching edge is required, this will need to be requested through the product modification request process and may be subject to additional costs. Due to varying manufacturing processes and quality issues with some laminates, some requests may be denied. Extended lead times and minimum order quantities may apply on orders containing special laminates. Contact the product modification team for questions or additional information regarding special laminates and pricing.

SPECIAL SERVICES

Special Carton Marking

With specially marked information N/C

Shipping

Ships **knocked down, FOB Bonduel, WI 54107, freight prepaid.** Freight class 70.

Specifications and prices are subject to change without prior notice.

Ruckus® Activity Table (Delivered Pricing)

1-1/4" Top - 74P Edge



Ruckus® Activity Table (Delivered Pricing)

1-1/4" Top - 74P Edge

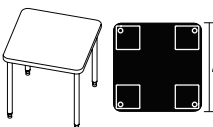
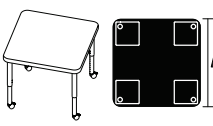
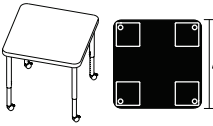
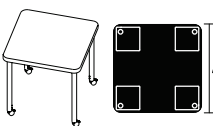
MODEL	A	MODEL NUMBER					Approx. Packaged Weight	Delivered Pricing	Chrome Upcharge add to list price	Laminate Grade 2 add to list price
		Basic Model/Edge Style	Edge Color	Surface Finish	Base Finish	Base Option				
 <p>Fixed Height Square Table, 29" H</p> <ul style="list-style-type: none"> • Casters and glides are interchangeable • Tables are designed for maximum leg spacing • All corners of surface are rounded • Specify casters/glides to wheelbarrow 	30"	RTEAC30	<input type="checkbox"/>	<input type="checkbox"/>	65.30#	\$ 599	\$ 70	\$ 27		
	36"	RTEAC36	<input type="checkbox"/>	<input type="checkbox"/>	79.00#	689	70	37		
	42"	RTEAC42	<input type="checkbox"/>	<input type="checkbox"/>	95.30#	781	70	37		
	48"	RTEAC48	<input type="checkbox"/>	<input type="checkbox"/>	114.00#	847	70	37		
RTEAC										
 <p>Floor Height Adjustable Square Table, 12 to 19" H</p> <ul style="list-style-type: none"> • Tables are designed for maximum leg spacing • All corners of surface are rounded • Base only available in glides • Legs adjust with screws in 1" increments • Legs are factory pre-set at 19"H 	30"	RTEHC30	<input type="checkbox"/>	<input type="checkbox"/>	62.80#	\$ 689	\$ 75	\$ 27		
	36"	RTEHC36	<input type="checkbox"/>	<input type="checkbox"/>	76.50#	779	75	37		
	42"	RTEHC42	<input type="checkbox"/>	<input type="checkbox"/>	92.80#	875	75	37		
	48"	RTEHC48	<input type="checkbox"/>	<input type="checkbox"/>	111.50#	944	75	37		
RTEHC										
 <p>Sit Height Adjustable Square Table, 20 to 33" H</p> <ul style="list-style-type: none"> • Casters and glides are interchangeable • Tables are designed for maximum leg spacing • All corners of surface are rounded • Specify casters/glides to wheelbarrow • Legs adjust with screws in 1" increments • Legs are factory pre-set at 29"H 	30"	RTEEC30	<input type="checkbox"/>	<input type="checkbox"/>	67.30#	\$ 679	\$ 77	\$ 27		
	36"	RTEEC36	<input type="checkbox"/>	<input type="checkbox"/>	81.00#	770	77	37		
	42"	RTEEC42	<input type="checkbox"/>	<input type="checkbox"/>	97.30#	861	77	37		
	48"	RTEEC48	<input type="checkbox"/>	<input type="checkbox"/>	116.00#	930	77	37		
RTEEC										
 <p>Sit-Stand Height Adjustable Square Table, 29 to 42" H</p> <ul style="list-style-type: none"> • Casters and glides are interchangeable • Tables are designed for maximum leg spacing • All corners of surface are rounded • Specify casters/glides to wheelbarrow • Legs adjust with screws in 1" increments • Legs are factory pre-set at 29"H 	30"	RTEFC30	<input type="checkbox"/>	<input type="checkbox"/>	71.30#	\$ 698	\$ 88	\$ 27		
	36"	RTEFC36	<input type="checkbox"/>	<input type="checkbox"/>	85.00#	789	88	37		
	42"	RTEFC42	<input type="checkbox"/>	<input type="checkbox"/>	101.30#	883	88	37		
	48"	RTEFC48	<input type="checkbox"/>	<input type="checkbox"/>	120.00#	947	88	37		
RTEFC										

A **B** **C** **D** **E**

HOW TO ORDER

- Indicate the following information on order form:
- Quantity of each item.
 - Model number, including options. See "How To Build a Model Number".
 - Any special service required.

Note: • The indicates that a choice is required.
 • The absence of the indicates that no choice is required.
 • Alpha-numeric characters in place of indicate that no other alternatives are available.

HOW TO BUILD A MODEL NUMBER

Felt glides - GFT and Nylon glides - GNY

- A** Select basic model/edge style.
74P - 1-1/4" laminate top w/74P edge band
- B** Select edge color.
 Refer to the **Product Color Options** page in this price list.
- C** Select surface finish.
 Refer to the **Product Color Options** page in this price list.
- D** Select base finish.
 Refer to the **Product Color Options** page in this price list.
- E** Select base option.
CCC - Casters
BCF - Casters/felt glides
BCN - Casters/nylon glides
GFT - Felt glides
GNY - Nylon glides
 Base options for Floor Activity Height are ONLY

FINISH INFORMATION

Additional Laminate Offering
 KI offers laminates beyond those offered in the standard offering. Laminates that are currently available in the program can be viewed in KI product specification tools. Requests to add laminates to the program can be submitted via the product modification request process. Please note, requests to add laminates to the program must include the laminate manufacturer's name, color/pattern number, and finish code. Edge options are limited to standard edge colors. If a matching edge is required, this will need to be requested through the product modification request process and may be subject to additional costs. Due to varying manufacturing processes and quality issues with some laminates, some requests may be denied. Extended lead times and minimum order quantities may apply on orders containing special laminates. Contact the product modification team for questions or additional information regarding special laminates and pricing.

SPECIAL SERVICES

Special Carton Marking
 With specially marked information N/C

Shipping
 Ships **knocked down, FOB Bonduel, WI 54107, freight prepaid.** Freight class 70.

Specifications and prices are subject to change without prior notice.

Ruckus® Activity Table (Delivered Pricing)

1-1/4" Top - 74P Edge



Ruckus® Activity Table (Delivered Pricing)

1-1/4" Top - 74P Edge

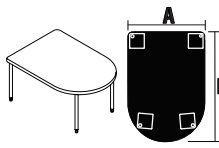
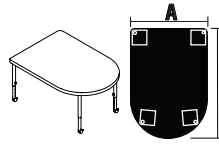
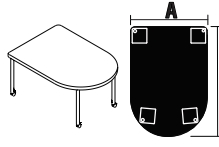
MODEL	A x B	MODEL NUMBER					Approx. Packaged Weight	Delivered Pricing	Chrome Upcharge add to list price	Laminate Grade 2 add to list price
		Basic Model/Edge Style	Edge Color	Surface Finish	Base Finish	Base Option				
 <p>Fixed Height D-Shaped Table, 29" H</p> <ul style="list-style-type: none"> • Casters and glides are interchangeable • Tables are designed for maximum leg spacing • All corners of surface are rounded • Specify casters/glides to wheelbarrow 	42 x 60"	RTEAD4260	<input type="checkbox"/>	<input type="checkbox"/>	<input type="checkbox"/>	<input type="checkbox"/>	115.00#	\$ 882	\$ 70	\$ 53
	48 x 60"	RTEAD4860	<input type="checkbox"/>	<input type="checkbox"/>	<input type="checkbox"/>	<input type="checkbox"/>	125.00#	894	70	53
	48 x 72"	RTEAD4872	<input type="checkbox"/>	<input type="checkbox"/>	<input type="checkbox"/>	<input type="checkbox"/>	145.00#	1015	70	53
	60 x 72"	RTEAD6072	<input type="checkbox"/>	<input type="checkbox"/>	<input type="checkbox"/>	<input type="checkbox"/>	170.00#	1060	70	105
RTEAD										
 <p>Sit Height Adjustable D-Shaped Table, 20 to 33" H</p> <ul style="list-style-type: none"> • Casters and glides are interchangeable • Tables are designed for maximum leg spacing • All corners of surface are rounded • Specify casters/glides to wheelbarrow • Legs adjust with screws in 1" increments • Legs are factory pre-set at 29"H 	42 x 60"	RTEED4260	<input type="checkbox"/>	<input type="checkbox"/>	<input type="checkbox"/>	<input type="checkbox"/>	117.00#	\$ 960	\$ 77	\$ 53
	48 x 60"	RTEED4860	<input type="checkbox"/>	<input type="checkbox"/>	<input type="checkbox"/>	<input type="checkbox"/>	127.00#	974	77	53
	48 x 72"	RTEED4872	<input type="checkbox"/>	<input type="checkbox"/>	<input type="checkbox"/>	<input type="checkbox"/>	147.00#	1096	77	53
	60 x 72"	RTEED6072	<input type="checkbox"/>	<input type="checkbox"/>	<input type="checkbox"/>	<input type="checkbox"/>	172.00#	1144	77	105
RTEED										
 <p>Sit-Stand Height Adjustable D-Shaped Table, 29 to 42" H</p> <ul style="list-style-type: none"> • Casters and glides are interchangeable • Tables are designed for maximum leg spacing • All corners of surface are rounded • Specify casters/glides to wheelbarrow • Legs adjust with screws in 1" increments • Legs are factory pre-set at 29"H 	42 x 60"	RTEFD4260	<input type="checkbox"/>	<input type="checkbox"/>	<input type="checkbox"/>	<input type="checkbox"/>	121.00#	\$ 980	\$ 88	\$ 53
	48 x 60"	RTEFD4860	<input type="checkbox"/>	<input type="checkbox"/>	<input type="checkbox"/>	<input type="checkbox"/>	131.00#	996	88	53
	48 x 72"	RTEFD4872	<input type="checkbox"/>	<input type="checkbox"/>	<input type="checkbox"/>	<input type="checkbox"/>	151.00#	1117	88	53
	60 x 72"	RTEFD6072	<input type="checkbox"/>	<input type="checkbox"/>	<input type="checkbox"/>	<input type="checkbox"/>	176.00#	1164	88	105
RTEFD										

A B C D E

HOW TO ORDER

- Indicate the following information on order form:
1. Quantity of each item.
 2. Model number, including options. See "How To Build a Model Number".
 3. Any special service required.

Note: • The indicates that a choice is required.
 • The absence of the indicates that no choice is required.
 • Alpha-numeric characters in place of indicate that no other alternatives are available.

HOW TO BUILD A MODEL NUMBER

- A** Select basic model/edge style.
74P - 1-1/4" laminate top w/74P edge band
- B** Select edge color.
 Refer to the **Product Color Options** page in this price list.
- C** Select surface finish.
 Refer to the **Product Color Options** page in this price list.
- D** Select base finish.
 Refer to the **Product Color Options** page in this price list.
- E** Select base option.

CCC	- Casters
BCF	- Casters/felt glides
BCN	- Casters/nylon glides
GFT	- Felt glides
GNV	- Nylon glides

FINISH INFORMATION

Additional Laminate Offering
 KI offers laminates beyond those offered in the standard offering. Laminates that are currently available in the program can be viewed in KI product specification tools. Requests to add laminates to the program can be submitted via the product modification request process. Please note, requests to add laminates to the program must include the laminate manufacturer's name, color/pattern number, and finish code. Edge options are limited to standard edge colors. If a matching edge is required, this will need to be requested through the product modification request process and may be subject to additional costs. Due to varying manufacturing processes and quality issues with some laminates, some requests may be denied. Extended lead times and minimum order quantities may apply on orders containing special laminates. Contact the product modification team for questions or additional information regarding special laminates and pricing.

SPECIAL SERVICES

Special Carton Marking

With specially marked information N/C

Shipping
 Ships **knocked down, FOB Bonduel, WI 54107, freight prepaid**. Freight class 70.

Specifications and prices are subject to change without prior notice.

Ruckus® Activity Table (Delivered Pricing)

1-1/4" Top - 74P Edge



Ruckus® Activity Table (Delivered Pricing)

1-1/4" Top - 74P Edge

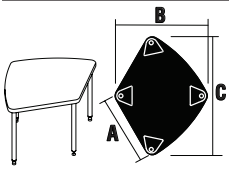
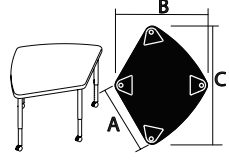
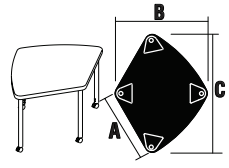
MODEL	A x B x C	MODEL NUMBER					Approx. Packaged Weight	Delivered Pricing	Chrome Upcharge add to list price	Laminate Grade 2 add to list price
		Basic Model/Edge Style	Edge Color	Surface Finish	Base Finish	Base Option				
 <p>Fixed Height Diamond Table, 29" H</p> <ul style="list-style-type: none"> • Casters and glides are interchangeable • Tables are designed for maximum leg spacing • All corners of surface are rounded • Specify casters/glides to wheelbarrow • 3 tables combine to form a guitar pick 	30 x 39 x 50"	RTEAE30-74P	<input type="checkbox"/>	<input type="checkbox"/>	<input type="checkbox"/>	48.00#	\$ 900	\$ 70	\$ 53	
	36 x 47 x 60"	RTEAE36-74P	<input type="checkbox"/>	<input type="checkbox"/>	<input type="checkbox"/>	59.00#	831	70	53	
RTEAE										
 <p>Sit Height Adjustable Diamond Table, 20 to 33" H</p> <ul style="list-style-type: none"> • Casters and glides are interchangeable • Tables are designed for maximum leg spacing • All corners of surface are rounded • Specify casters/glides to wheelbarrow • Legs adjust with screws in 1" increments • Legs are factory pre-set at 29"H • 3 tables combine to form a guitar pick 	30 x 39 x 50"	RTEEE30-74P	<input type="checkbox"/>	<input type="checkbox"/>	<input type="checkbox"/>	50.00#	\$ 827	\$ 77	\$ 53	
	36 x 47 x 60"	RTEEE36-74P	<input type="checkbox"/>	<input type="checkbox"/>	<input type="checkbox"/>	61.00#	892	77	53	
RTEEE										
 <p>Sit-Stand Height Adjustable Diamond Table, 29 to 42" H</p> <ul style="list-style-type: none"> • Casters and glides are interchangeable • Tables are designed for maximum leg spacing • All corners of surface are rounded • Specify casters/glides to wheelbarrow • Legs adjust with screws in 1" increments • Legs are factory pre-set at 29"H • 3 tables combine to form a guitar pick 	30 x 39 x 50"	RTEFE30-74P	<input type="checkbox"/>	<input type="checkbox"/>	<input type="checkbox"/>	54.00#	\$ 871	\$ 88	\$ 53	
	36 x 47 x 60"	RTEFE36-74P	<input type="checkbox"/>	<input type="checkbox"/>	<input type="checkbox"/>	65.00#	940	88	53	
RTEFE										

A B C D E

HOW TO ORDER

- Indicate the following information on order form:
1. Quantity of each item.
 2. Model number, including options. See "How To Build a Model Number".
 3. Any special service required.

Note: • The indicates that a choice is required.
 • The absence of the indicates that no choice is required.
 • Alpha-numeric characters in place of indicate that no other alternatives are available.

HOW TO BUILD A MODEL NUMBER

- A** Select basic model/edge style.
74P - 1-1/4" laminate top w/74P edge band
- B** Select edge color.
 Refer to the **Product Color Options** page in this price list.
- C** Select surface finish.
 Refer to the **Product Color Options** page in this price list.
- D** Select base finish.
 Refer to the **Product Color Options** page in this price list.
- E** Select base option.

CCC	- Casters
BCF	- Casters/felt glides
BCN	- Casters/nylon glides
GFT	- Felt glides
GNV	- Nylon glides

FINISH INFORMATION

Additional Laminate Offering

KI offers laminates beyond those offered in the standard offering. Laminates that are currently available in the program can be viewed in KI product specification tools. Requests to add laminates to the program can be submitted via the product modification request process. Please note, requests to add laminates to the program must include the laminate manufacturer's name, color/pattern number, and finish code. Edge options are limited to standard edge colors. If a matching edge is required, this will need to be requested through the product modification request process and may be subject to additional costs. Due to varying manufacturing processes and quality issues with some laminates, some requests may be denied. Extended lead times and minimum order quantities may apply on orders containing special laminates. Contact the product modification team for questions or additional information regarding special laminates and pricing.

SPECIAL SERVICES

Special Carton Marking

With specially marked information N/C

Shipping

Ships **knocked down, FOB Bonduel, WI 54107, freight prepaid.** Freight class 70.

Specifications and prices are subject to change without prior notice.

Ruckus® Activity Table (Delivered Pricing)

1-1/4" Top - 74P Edge



Ruckus® Activity Table (Delivered Pricing)

1-1/4" Top - 74P Edge

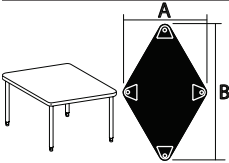
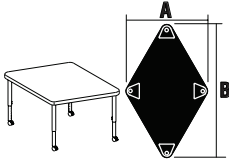
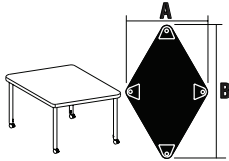
MODEL	Features	A x B	MODEL NUMBER					Approx. Packaged Weight	Delivered Pricing	Chrome Upcharge add to list price	Laminate Grade 2 add to list price
			Basic Model/Edge Style	Edge Color	Surface Finish	Base Finish	Base Option				
 <p>Fixed Height Kite Table, 29" H</p> <ul style="list-style-type: none"> • Casters and glides are interchangeable • Tables are designed for maximum leg spacing • All corners of surface are rounded • Specify casters/glides to wheelbarrow • 3 Tables combine to form a hexagon 	Small	35 x 57"	RTEAJ34-74P	<input type="checkbox"/>	<input type="checkbox"/>	<input type="checkbox"/>	<input type="checkbox"/>	47.00#	\$ 775		
	Large	40 x 66"	RTEAJ39-74P	<input type="checkbox"/>	<input type="checkbox"/>	<input type="checkbox"/>	<input type="checkbox"/>	55.00#	884	\$ 70	\$ 53
 <p>Sit Height Adjustable Kite Table, 20 to 33" H</p> <ul style="list-style-type: none"> • Casters and glides are interchangeable • Tables are designed for maximum leg spacing • All corners of surface are rounded • Specify casters/glides to wheelbarrow • Legs adjust with screws in 1" increments • Legs are factory pre-set at 29"H • 3 Tables combine to form a hexagon 	Small	35 x 57"	RTEEJ34-74P	<input type="checkbox"/>	<input type="checkbox"/>	<input type="checkbox"/>	<input type="checkbox"/>	49.00#	\$ 821	\$ 77	
	Large	40 x 66"	RTEEJ39-74P	<input type="checkbox"/>	<input type="checkbox"/>	<input type="checkbox"/>	<input type="checkbox"/>	57.00#	927	77	\$ 53
 <p>Sit-Stand Height Adjustable Kite Table, 29 to 42" H</p> <ul style="list-style-type: none"> • Casters and glides are interchangeable • Tables are designed for maximum leg spacing • All corners of surface are rounded • Specify casters/glides to wheelbarrow • Legs adjust with screws in 1" increments • Legs are factory pre-set at 29"H • 3 Tables combine to form a hexagon 	Small	35 x 57"	RTEFJ34-74P	<input type="checkbox"/>	<input type="checkbox"/>	<input type="checkbox"/>	<input type="checkbox"/>	53.00#	\$ 880	\$ 88	
	Large	40 x 66"	RTEFJ39-74P	<input type="checkbox"/>	<input type="checkbox"/>	<input type="checkbox"/>	<input type="checkbox"/>	61.00#	989	88	\$ 53

A **B** **C** **D** **E**

HOW TO ORDER

- Indicate the following information on order form:
1. Quantity of each item.
 2. Model number, including options. See "How To Build a Model Number".
 3. Any special service required.

Note: • The indicates that a choice is required.
 • The absence of the indicates that no choice is required.
 • Alpha-numeric characters in place of indicate that no other alternatives are available.

HOW TO BUILD A MODEL NUMBER

- A** Select basic model/edge style.
74P - 1-1/4" laminate top w/74P edge band
- B** Select edge color.
 Refer to the **Product Color Options** page in this price list.
- C** Select surface finish.
 Refer to the **Product Color Options** page in this price list.
- D** Select base finish.
 Refer to the **Product Color Options** page in this price list.
- E** Select base option.

CCC	- Casters
BCF	- Casters/felt glides
BCN	- Casters/nylon glides
GFT	- Felt glides
GNY	- Nylon glides

FINISH INFORMATION

Additional Laminate Offering

KI offers laminates beyond those offered in the standard offering. Laminates that are currently available in the program can be viewed in KI product specification tools. Requests to add laminates to the program can be submitted via the product modification request process. Please note, requests to add laminates to the program must include the laminate manufacturer's name, color/pattern number, and finish code. Edge options are limited to standard edge colors. If a matching edge is required, this will need to be requested through the product modification request process and may be subject to additional costs. Due to varying manufacturing processes and quality issues with some laminates, some requests may be denied. Extended lead times and minimum order quantities may apply on orders containing special laminates. Contact the product modification team for questions or additional information regarding special laminates and pricing.

SPECIAL SERVICES

Special Carton Marking

With specially marked information N/C

Shipping

Ships **knocked down, FOB Bonduel, WI 54107, freight prepaid.** Freight class 70.

Specifications and prices are subject to change without prior notice.



Ruckus® Activity Table (Delivered Pricing)

1-1/4" Top - 74P Edge

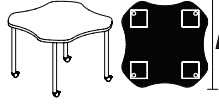
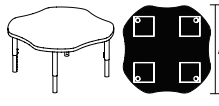

Ruckus® Activity Table (Delivered Pricing)

1-1/4" Top - 74P Edge

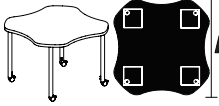
MODEL	A	MODEL NUMBER					Approx. Packaged Weight	Delivered Pricing	Chrome Upcharge add to list price	Laminate Grade 2 add to list price
		Basic Model/Edge Style	Edge Color	Surface Finish	Base Finish	Base Option				
 <p>Fixed Height Clover Table, 29" H</p> <ul style="list-style-type: none"> • Casters and glides are interchangeable • Tables are designed for maximum leg spacing • All corners of surface are rounded • Specify casters/glides to wheelbarrow 	48"	RTEAY48	<input type="checkbox"/> <input type="checkbox"/> <input type="checkbox"/>	<input type="checkbox"/> <input type="checkbox"/> <input type="checkbox"/>	<input type="checkbox"/> <input type="checkbox"/>	<input type="checkbox"/> <input type="checkbox"/> <input type="checkbox"/>	98.80#	\$ 738	\$ 70	\$ 37
	54"	RTEAY54	<input type="checkbox"/> <input type="checkbox"/> <input type="checkbox"/>	<input type="checkbox"/> <input type="checkbox"/> <input type="checkbox"/>	<input type="checkbox"/> <input type="checkbox"/>	<input type="checkbox"/> <input type="checkbox"/> <input type="checkbox"/>	118.70#	777	70	53
RTEAY										
 <p>Floor Height Adjustable Clover Table, 12 to 19" H</p> <ul style="list-style-type: none"> • Tables are designed for maximum leg spacing • All corners of surface are rounded • Legs adjust with screws in 1" increments • Legs are factory pre-set at 19"H • Base only available in glides 	39"	RTEHY39	<input type="checkbox"/> <input type="checkbox"/> <input type="checkbox"/>	<input type="checkbox"/> <input type="checkbox"/> <input type="checkbox"/>	<input type="checkbox"/> <input type="checkbox"/>	<input type="checkbox"/> <input type="checkbox"/> <input type="checkbox"/>	73.70#	\$ 720	\$ 75	\$ 37
	48"	RTEHY48	<input type="checkbox"/> <input type="checkbox"/> <input type="checkbox"/>	<input type="checkbox"/> <input type="checkbox"/> <input type="checkbox"/>	<input type="checkbox"/> <input type="checkbox"/>	<input type="checkbox"/> <input type="checkbox"/> <input type="checkbox"/>	98.80#	794	75	37
RTEHY										
 <p>Sit Height Adjustable Clover Table, 20 to 33" H</p> <ul style="list-style-type: none"> • Casters and glides are interchangeable • Tables are designed for maximum leg spacing • All corners of surface are rounded • Specify casters/glides to wheelbarrow • Legs adjust with screws in 1" increments • Legs are factory pre-set at 29"H 	39"	RTEEY39	<input type="checkbox"/> <input type="checkbox"/> <input type="checkbox"/>	<input type="checkbox"/> <input type="checkbox"/> <input type="checkbox"/>	<input type="checkbox"/> <input type="checkbox"/>	<input type="checkbox"/> <input type="checkbox"/> <input type="checkbox"/>	73.70#	\$ 724	\$ 77	\$ 37
	48"	RTEEY48	<input type="checkbox"/> <input type="checkbox"/> <input type="checkbox"/>	<input type="checkbox"/> <input type="checkbox"/> <input type="checkbox"/>	<input type="checkbox"/> <input type="checkbox"/>	<input type="checkbox"/> <input type="checkbox"/> <input type="checkbox"/>	98.80#	797	77	37
	54"	RTEEY54	<input type="checkbox"/> <input type="checkbox"/> <input type="checkbox"/>	<input type="checkbox"/> <input type="checkbox"/> <input type="checkbox"/>	<input type="checkbox"/> <input type="checkbox"/>	<input type="checkbox"/> <input type="checkbox"/> <input type="checkbox"/>	118.70#	842	77	53
RTEEY										
 <p>Sit-Stand Height Adjustable Clover Table, 29 to 42" H</p> <ul style="list-style-type: none"> • Casters and glides are interchangeable • Tables are designed for maximum leg spacing • All corners of surface are rounded • Specify casters/glides to wheelbarrow • Legs adjust with screws in 1" increments • Legs are factory pre-set at 29"H 	48"	RTEFY48	<input type="checkbox"/> <input type="checkbox"/> <input type="checkbox"/>	<input type="checkbox"/> <input type="checkbox"/> <input type="checkbox"/>	<input type="checkbox"/> <input type="checkbox"/>	<input type="checkbox"/> <input type="checkbox"/> <input type="checkbox"/>	98.80#	\$ 823	\$ 88	\$ 37
	54"	RTEFY54	<input type="checkbox"/> <input type="checkbox"/> <input type="checkbox"/>	<input type="checkbox"/> <input type="checkbox"/> <input type="checkbox"/>	<input type="checkbox"/> <input type="checkbox"/>	<input type="checkbox"/> <input type="checkbox"/> <input type="checkbox"/>	118.70#	868	88	53
RTEFY										

A **B** **C** **D** **E**

HOW TO ORDER

- Indicate the following information on order form:
1. Quantity of each item.
 2. Model number, including options. See "How To Build a Model Number".
 3. Any special service required.

Note: • The indicates that a choice is required.
 • The absence of the indicates that no choice is required.
 • Alpha-numeric characters in place of indicate that no other alternatives are available.

HOW TO BUILD A MODEL NUMBER

- A** Select basic model/edge style.
74P - 1-1/4" laminate top w/74P edge band
- B** Select edge color.
 Refer to the **Product Color Options** page in this price list.
- C** Select surface finish.
 Refer to the **Product Color Options** page in this price list.
- D** Select base finish.
 Refer to the **Product Color Options** page in this price list.
- E** Select base option.
CCC - Casters
BCF - Casters/felt glides
BCN - Casters/nylon glides
GFT - Felt glides
GNV - Nylon glides
 Base options for Floor Height Adjustable are

ONLY Felt glides - GFT and Nylon glides - GNV

FINISH INFORMATION

Additional Laminate Offering

KI offers laminates beyond those offered in the standard offering. Laminates that are currently available in the program can be viewed in KI product specification tools. Requests to add laminates to the program can be submitted via the product modification request process. Please note, requests to add laminates to the program must include the laminate manufacturer's name, color/pattern number, and finish code. Edge options are limited to standard edge colors. If a matching edge is required, this will need to be requested through the product modification request process and may be subject to additional costs. Due to varying manufacturing processes and quality issues with some laminates, some requests may be denied. Extended lead times and minimum order quantities may apply on orders containing special laminates. Contact the product modification team for questions or additional information regarding special laminates and pricing.

SPECIAL SERVICES

Special Carton Marking

With specially marked information N/C

Shipping

Ships **knocked down, FOB Bonduel, WI 54107, freight prepaid.** Freight class 70.

Specifications and prices are subject to change without prior notice.

Ruckus® Activity Table (Delivered Pricing)

1-1/4" Top - 74P Edge



Ruckus® Activity Table (Delivered Pricing)

1-1/4" Top - 74P Edge

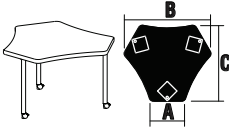
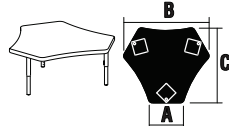
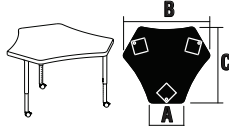
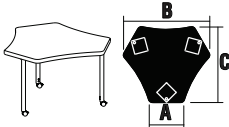
MODEL	A x B x C	MODEL NUMBER					Approx. Packaged Weight	Delivered Pricing	Chrome Upcharge add to list price	Laminate Grade 2 add to list price
		Basic Model/Edge Style	Edge Color	Surface Finish	Base Finish	Base Option				
 <p>Fixed Height 3-Leg Sprocket Table, 29" H</p> <ul style="list-style-type: none"> • Casters and glides are interchangeable • Tables are designed for maximum leg spacing • All corners of surface are rounded • Specify casters/glides to wheelbarrow • 3-Leg is primarily a 3-person table 	20 x 51 x 45"	RTEAG20	<input type="checkbox"/> <input type="checkbox"/> <input type="checkbox"/>	<input type="checkbox"/> <input type="checkbox"/> <input type="checkbox"/>	<input type="checkbox"/> <input type="checkbox"/>	<input type="checkbox"/> <input type="checkbox"/>	80.00#	\$ 816	\$ 52	\$ 53
	24 x 53 x 46"	RTEAG24	<input type="checkbox"/> <input type="checkbox"/> <input type="checkbox"/>	<input type="checkbox"/> <input type="checkbox"/> <input type="checkbox"/>	<input type="checkbox"/> <input type="checkbox"/>	<input type="checkbox"/> <input type="checkbox"/>	86.00#	822	52	53
RTEAG										
 <p>Floor Height Adjustable 3-Leg Sprocket table, 12 to 19" H</p> <ul style="list-style-type: none"> • Tables are designed for maximum leg spacing • All corners of surface are rounded • Legs adjust with screws in 1" increments • Legs are factory pre-set at 19"H • 3-Leg is primarily a 3-person table • Base only available in glides 	20 x 51 x 45"	RTEHG20	<input type="checkbox"/> <input type="checkbox"/> <input type="checkbox"/>	<input type="checkbox"/> <input type="checkbox"/> <input type="checkbox"/>	<input type="checkbox"/> <input type="checkbox"/>	<input type="checkbox"/> <input type="checkbox"/>	78.20#	\$ 876	\$ 55	\$ 53
	24 x 53 x 46"	RTEHG24	<input type="checkbox"/> <input type="checkbox"/> <input type="checkbox"/>	<input type="checkbox"/> <input type="checkbox"/> <input type="checkbox"/>	<input type="checkbox"/> <input type="checkbox"/>	<input type="checkbox"/> <input type="checkbox"/>	84.20#	883	55	53
RTEHG										
 <p>Sit Height Adjustable 3-Leg Sprocket Table, 20 to 33" H</p> <ul style="list-style-type: none"> • Casters and glides are interchangeable • Tables are designed for maximum leg spacing • All corners of surface are rounded • Specify casters/glides to wheelbarrow • Legs adjust with screws in 1" increments • Legs are factory pre-set at 29"H • 3-Leg is primarily a 3-person table 	20 x 51 x 45"	RTEEG20	<input type="checkbox"/> <input type="checkbox"/> <input type="checkbox"/>	<input type="checkbox"/> <input type="checkbox"/> <input type="checkbox"/>	<input type="checkbox"/> <input type="checkbox"/>	<input type="checkbox"/> <input type="checkbox"/>	81.50#	\$ 863	\$ 58	\$ 53
	24 x 53 x 46"	RTEEG24	<input type="checkbox"/> <input type="checkbox"/> <input type="checkbox"/>	<input type="checkbox"/> <input type="checkbox"/> <input type="checkbox"/>	<input type="checkbox"/> <input type="checkbox"/>	<input type="checkbox"/> <input type="checkbox"/>	87.50#	870	58	53
RTEEG										
 <p>Sit-Stand Height Adjustable 3-Leg Sprocket Table, 29 to 42" H</p> <ul style="list-style-type: none"> • Casters and glides are interchangeable • Tables are designed for maximum leg spacing • All corners of surface are rounded • Specify casters/glides to wheelbarrow • Legs adjust with screws in 1" increments • Legs are factory pre-set at 29"H • 3-Leg is primarily a 3-person table 	20 x 51 x 45"	RTEFG20	<input type="checkbox"/> <input type="checkbox"/> <input type="checkbox"/>	<input type="checkbox"/> <input type="checkbox"/> <input type="checkbox"/>	<input type="checkbox"/> <input type="checkbox"/>	<input type="checkbox"/> <input type="checkbox"/>	84.50#	\$ 875	\$ 68	\$ 53
	24 x 53 x 46"	RTEFG24	<input type="checkbox"/> <input type="checkbox"/> <input type="checkbox"/>	<input type="checkbox"/> <input type="checkbox"/> <input type="checkbox"/>	<input type="checkbox"/> <input type="checkbox"/>	<input type="checkbox"/> <input type="checkbox"/>	90.50#	883	68	53
RTEFG										

A

B

C

D

E

HOW TO ORDER

- Indicate the following information on order form:
1. Quantity of each item.
 2. Model number, including options. See "How To Build a Model Number".
 3. Any special service required.

Note: • The indicates that a choice is required.

- The absence of the indicates that no choice is required.
- Alpha-numeric characters in place of indicate that no other alternatives are available.

HOW TO BUILD A MODEL NUMBER

A Select basic model/edge style.
74P - 1-1/4" laminate top w/74P edge band

B Select edge color.
 Refer to the **Product Color Options** page in this price list.

C Select surface finish.
 Refer to the **Product Color Options** page in this price list.

D Select base finish.
 Refer to the **Product Color Options** page in this price list.

E Select base option.
CCC - Casters
BCF - Casters/felt glides
BCN - Casters/nylon glides
GFT - Felt glides
GNV - Nylon glides
 Base options for Floor Height Adjustable are

ONLY Felt glides - GFT and Nylon glides - GNV

FINISH INFORMATION

Additional Laminate Offering

KI offers laminates beyond those offered in the standard offering. Laminates that are currently available in the program can be viewed in KI product specification tools. Requests to add laminates to the program can be submitted via the product modification request process. Please note, requests to add laminates to the program must include the laminate manufacturer's name, color/pattern number, and finish code. Edge options are limited to standard edge colors. If a matching edge is required, this will need to be requested through the product modification request process and may be subject to additional costs. Due to varying manufacturing processes and quality issues with some laminates, some requests may be denied. Extended lead times and minimum order quantities may apply on orders containing special laminates. Contact the product modification team for questions or additional information regarding special laminates and pricing.

SPECIAL SERVICES

Special Carton Marking

With specially marked information N/C

Shipping
 Ships **knocked down, FOB Bonduel, WI 54107, freight prepaid.** Freight class 70.

Specifications and prices are subject to change without prior notice.

Ruckus® Activity Table (Delivered Pricing)

1-1/4" Top - 74P Edge



Ruckus® Activity Table (Delivered Pricing)

1-1/4" Top - 74P Edge

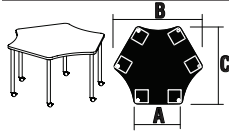
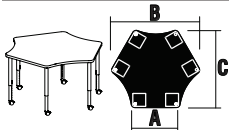
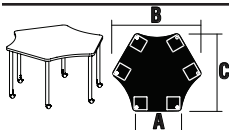
MODEL	A x B x C	MODEL NUMBER					Approx. Packaged Weight	Delivered Pricing	Chrome Upcharge add to list price	Laminate Grade 2 add to list price
		Basic Model/Edge Style	Edge Color	Surface Finish	Base Finish	Base Option				
 <p>Fixed Height 6-Leg Sprocket Table, 29" H</p> <ul style="list-style-type: none"> • Casters and glides are interchangeable • Tables are designed for maximum leg spacing • All corners of surface are rounded • Specify casters/glides to wheelbarrow • 6-Leg can accommodate up to 6 people 	30 x 55 x 48"	RTEAG30	<input type="checkbox"/> <input type="checkbox"/>	<input type="checkbox"/> <input type="checkbox"/>	<input type="checkbox"/>	<input type="checkbox"/> <input type="checkbox"/>	118.00#	\$ 1066	\$ 106	\$ 53
 <p>Sit Height Adjustable 6-Leg Sprocket Table, 20 to 33" H</p> <ul style="list-style-type: none"> • Casters and glides are interchangeable • Tables are designed for maximum leg spacing • All corners of surface are rounded • Specify casters/glides to wheelbarrow • Legs adjust with screws in 1" increments • Legs are factory pre-set at 29"H • 6-Leg can accommodate up to 6 people 	30 x 55 x 48"	RTEEG30	<input type="checkbox"/> <input type="checkbox"/>	<input type="checkbox"/> <input type="checkbox"/>	<input type="checkbox"/>	<input type="checkbox"/> <input type="checkbox"/>	121.00#	\$ 1167	\$ 116	\$ 53
 <p>Sit-Stand Height Adjustable 6-Leg Sprocket Table, 29 to 42" H</p> <ul style="list-style-type: none"> • Casters and glides are interchangeable • Tables are designed for maximum leg spacing • All corners of surface are rounded • Specify casters/glides to wheelbarrow • Legs adjust with screws in 1" increments • Legs are factory pre-set at 29"H • 6-Leg can accommodate up to 6 people 	30 x 55 x 48"	RTEFG30	<input type="checkbox"/> <input type="checkbox"/>	<input type="checkbox"/> <input type="checkbox"/>	<input type="checkbox"/>	<input type="checkbox"/> <input type="checkbox"/>	127.00#	\$ 1192	\$ 134	\$ 53

A B C D E

HOW TO ORDER

- Indicate the following information on order form:
1. Quantity of each item.
 2. Model number, including options. See "How To Build a Model Number".
 3. Any special service required.

Note: • The indicates that a choice is required.

- The absence of the indicates that no choice is required.
- Alpha-numeric characters in place of indicate that no other alternatives are available.

HOW TO BUILD A MODEL NUMBER

- A** Select basic model/edge style.
74P - 1-1/4" laminate top w/74P edge band
- B** Select edge color.
Refer to the **Product Color Options** page in this price list.
- C** Select surface finish.
Refer to the **Product Color Options** page in this price list.
- D** Select base finish.
Refer to the **Product Color Options** page in this price list.
- E** Select base option.

CCC	- Casters
BCF	- Casters/felt glides
BCN	- Casters/nylon glides
GFT	- Felt glides
GNV	- Nylon glides

FINISH INFORMATION

Additional Laminate Offering

KI offers laminates beyond those offered in the standard offering. Laminates that are currently available in the program can be viewed in KI product specification tools. Requests to add laminates to the program can be submitted via the product modification request process. Please note, requests to add laminates to the program must include the laminate manufacturer's name, color/pattern number, and finish code. Edge options are limited to standard edge colors. If a matching edge is required, this will need to be requested through the product modification request process and may be subject to additional costs. Due to varying manufacturing processes and quality issues with some laminates, some requests may be denied. Extended lead times and minimum order quantities may apply on orders containing special laminates. Contact the product modification team for questions or additional information regarding special laminates and pricing.

SPECIAL SERVICES

Special Carton Marking

With specially marked information N/C

Shipping

Ships **knocked down, FOB Bonduel, WI 54107, freight prepaid**. Freight class 70.

Specifications and prices are subject to change without prior notice.

Ruckus® Activity Table (Delivered Pricing)

1-1/4" Top - 74P Edge



Ruckus® Activity Table (Delivered Pricing)

1-1/4" Top - 74P Edge

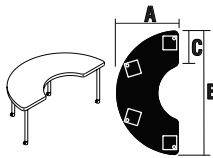
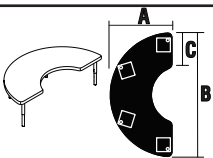
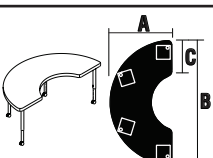
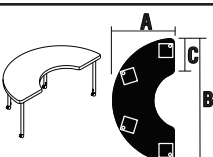
MODEL	A x B x C	MODEL NUMBER					Approx. Packaged Weight	Delivered Pricing	Chrome Upcharge add to list price	Laminate Grade 2 add to list price
		Basic Model/Edge Style	Edge Color	Surface Finish	Base Finish	Base Option				
 <p>Fixed Height Kidney Table, 29" H</p> <ul style="list-style-type: none"> • Casters and glides are interchangeable • Tables are designed for maximum leg spacing • All corners of surface are rounded • Specify casters/glides to wheelbarrow 	36 x 72 x 20"	RTEAF367220	<input type="checkbox"/>	<input type="checkbox"/>	<input type="checkbox"/>	93.00#	\$ 998	\$ 70	\$ 53	
	36 x 72 x 24"	RTEAF367224	<input type="checkbox"/>	<input type="checkbox"/>	<input type="checkbox"/>	97.00#	1004	70	53	
	36 x 83 x 30"	RTEAF368430	<input type="checkbox"/>	<input type="checkbox"/>	<input type="checkbox"/>	105.00#	1219	70	74	
	48 x 72 x 20"	RTEAF487220	<input type="checkbox"/>	<input type="checkbox"/>	<input type="checkbox"/>	125.00#	1104	70	53	
	48 x 72 x 24"	RTEAF487224	<input type="checkbox"/>	<input type="checkbox"/>	<input type="checkbox"/>	127.00#	1306	70	53	
	48 x 84 x 30"	RTEAF488430	<input type="checkbox"/>	<input type="checkbox"/>	<input type="checkbox"/>	140.00#	1308	70	74	
RTEAF										
 <p>Floor Height Adjustable Kidney Table, 12 to 19" H</p> <ul style="list-style-type: none"> • Tables are designed for maximum leg spacing • All corners of surface are rounded • Legs adjust with screws in 1" increments • Legs are factory pre-set at 19"H • Base only available in glides 	36 x 72 x 20"	RTEHF367220	<input type="checkbox"/>	<input type="checkbox"/>	<input type="checkbox"/>	89.50#	\$ 1078	\$ 75	\$ 53	
	36 x 72 x 24"	RTEHF367224	<input type="checkbox"/>	<input type="checkbox"/>	<input type="checkbox"/>	94.50#	1085	75	53	
	36 x 84 x 30"	RTEHF368430	<input type="checkbox"/>	<input type="checkbox"/>	<input type="checkbox"/>	102.50#	1300	75	74	
	48 x 72 x 20"	RTEHF487220	<input type="checkbox"/>	<input type="checkbox"/>	<input type="checkbox"/>	122.50#	1162	75	53	
	48 x 72 x 24"	RTEHF487224	<input type="checkbox"/>	<input type="checkbox"/>	<input type="checkbox"/>	124.50#	1167	75	53	
	48 x 84 x 30"	RTEHF488430	<input type="checkbox"/>	<input type="checkbox"/>	<input type="checkbox"/>	137.50#	1362	75	74	
RTEHF										
 <p>Sit Height Adjustable Kidney Table, 20 to 33" H</p> <ul style="list-style-type: none"> • Casters and glides are interchangeable • Tables are designed for maximum leg spacing • All corners of surface are rounded • Specify casters/glides to wheelbarrow • Legs adjust with screws in 1" increments • Legs are factory pre-set at 29"H 	36 x 72 x 20"	RTEEF367220	<input type="checkbox"/>	<input type="checkbox"/>	<input type="checkbox"/>	95.00#	\$ 1061	\$ 77	\$ 53	
	36 x 72 x 24"	RTEEF367224	<input type="checkbox"/>	<input type="checkbox"/>	<input type="checkbox"/>	99.00#	1067	77	53	
	36 x 83 x 30"	RTEEF368430	<input type="checkbox"/>	<input type="checkbox"/>	<input type="checkbox"/>	107.00#	1279	77	74	
	48 x 72 x 20"	RTEEF487220	<input type="checkbox"/>	<input type="checkbox"/>	<input type="checkbox"/>	127.00#	1143	77	53	
	48 x 72 x 24"	RTEEF487224	<input type="checkbox"/>	<input type="checkbox"/>	<input type="checkbox"/>	129.00#	1149	77	53	
	48 x 84 x 30"	RTEEF488430	<input type="checkbox"/>	<input type="checkbox"/>	<input type="checkbox"/>	142.00#	1340	77	74	
RTEEF										
 <p>Sit-Stand Height Adjustable Kidney Table, 29 to 42" H</p> <ul style="list-style-type: none"> • Casters and glides are interchangeable • Tables are designed for maximum leg spacing • All corners of surface are rounded • Specify casters/glides to wheelbarrow • Legs adjust with screws in 1" increments • Legs are factory pre-set at 29"H 	36 x 72 x 20"	RTEFF367220	<input type="checkbox"/>	<input type="checkbox"/>	<input type="checkbox"/>	99.00#	\$ 1084	\$ 88	\$ 53	
	36 x 72 x 24"	RTEFF367224	<input type="checkbox"/>	<input type="checkbox"/>	<input type="checkbox"/>	103.00#	1078	88	53	
	36 x 83 x 30"	RTEFF368430	<input type="checkbox"/>	<input type="checkbox"/>	<input type="checkbox"/>	111.00#	1296	88	74	
	48 x 72 x 20"	RTEFF487220	<input type="checkbox"/>	<input type="checkbox"/>	<input type="checkbox"/>	131.00#	1161	88	53	
	48 x 72 x 24"	RTEFF487224	<input type="checkbox"/>	<input type="checkbox"/>	<input type="checkbox"/>	133.00#	1168	88	53	
	48 x 84 x 30"	RTEFF488430	<input type="checkbox"/>	<input type="checkbox"/>	<input type="checkbox"/>	146.00#	1359	88	74	
RTEFF										

A **B** **C** **D** **E**

HOW TO ORDER

- Indicate the following information on order form:
1. Quantity of each item.
 2. Model number, including options. See "How To Build a Model Number".
 3. Any special service required.

Note: • The indicates that a choice is required.

- The absence of the indicates that no choice is required.
- Alpha-numeric characters in place of indicate that no other alternatives are available.

HOW TO BUILD A MODEL NUMBER

- A** Select basic model/edge style.
74P - 1-1/4" laminate top w/74P edge band
- B** Select edge color.
Refer to the **Product Color Options** page in this price list.
- C** Select surface finish.
Refer to the **Product Color Options** page in this price list.
- D** Select base finish.
Refer to the **Product Color Options** page in this price list.
- E** Select base option.
- CCC** - Casters
 - BCF** - Casters/felt glides
 - BCN** - Casters/nylon glides
 - GFT** - Felt glides
 - GNV** - Nylon glides
- Base options for Floor Height Adjustable are

ONLY Felt glides - GFT and Nylon glides - GNV

FINISH INFORMATION

Additional Laminate Offering

KI offers laminates beyond those offered in the standard offering. Laminates that are currently available in the program can be viewed in KI product specification tools. Requests to add laminates to the program can be submitted via the product modification request process. Please note, requests to add laminates to the program must include the laminate manufacturer's name, color/pattern number, and finish code. Edge options are limited to standard edge colors. If a matching edge is required, this will need to be requested through the product modification request process and may be subject to additional costs. Due to varying manufacturing processes and quality issues with some laminates, some requests may be denied. Extended lead times and minimum order quantities may apply on orders containing special laminates. Contact the product modification team for questions or additional information regarding special laminates and pricing.

SPECIAL SERVICES

Special Carton Marking

With specially marked information N/C

Shipping

Ships **knocked down, FOB Bonduel, WI 54107, freight prepaid.** Freight class 70.

Specifications and prices are subject to change without prior notice.

Ruckus® Activity Table (Delivered Pricing)

1-1/4" Top - 74P Edge



Ruckus® Activity Table (Delivered Pricing)

1-1/4" Top - 74P Edge

MODEL	A x B x C	MODEL NUMBER					Approx. Packaged Weight	Delivered Pricing	Chrome Upcharge add to list price	Laminate Grade 2 add to list price
		Basic Model/Edge Style	Edge Color	Surface Finish	Base Finish	Base Option				
<p>Fixed Height Horseshoe Table, 29" H</p> <ul style="list-style-type: none"> Casters and glides are interchangeable Tables are designed for maximum leg spacing All corners of surface are rounded Specify casters/glides to wheelbarrow 	48 x 72 x 20"	RTEAH487220	<input type="checkbox"/>	<input type="checkbox"/>	<input type="checkbox"/>	107.00#	\$ 1182	\$ 70	\$ 53	
	48 x 80 x 24"	RTEAH488024	<input type="checkbox"/>	<input type="checkbox"/>	<input type="checkbox"/>	120.00#	1387	70	74	
	48 x 92 x 30"	RTEAH489230	<input type="checkbox"/>	<input type="checkbox"/>	<input type="checkbox"/>	139.00#	1393	70	74	
	60 x 66 x 20"	RTEAH606620	<input type="checkbox"/>	<input type="checkbox"/>	<input type="checkbox"/>	121.00#	1244	70	105	
	60 x 72 x 24"	RTEAH607224	<input type="checkbox"/>	<input type="checkbox"/>	<input type="checkbox"/>	138.00#	1263	70	105	
	60 x 86 x 30"	RTEAH608630	<input type="checkbox"/>	<input type="checkbox"/>	<input type="checkbox"/>	161.00#	1448	70	105	
RTEAH										
<p>Floor Height Adjustable Horseshoe Table, 12 to 19" H</p> <ul style="list-style-type: none"> Tables are designed for maximum leg spacing All corners of surface are rounded Legs adjust with screws in 1" increments Legs are factory pre-set at 19"H Base only available in glides 	48 x 72 x 20"	RTEHH487220	<input type="checkbox"/>	<input type="checkbox"/>	<input type="checkbox"/>	104.50#	\$ 1268	\$ 75	\$ 53	
	48 x 80 x 24"	RTEHH488024	<input type="checkbox"/>	<input type="checkbox"/>	<input type="checkbox"/>	117.50#	1472	75	74	
	48 x 92 x 30"	RTEHH489230	<input type="checkbox"/>	<input type="checkbox"/>	<input type="checkbox"/>	136.50#	1473	75	74	
	60 x 66 x 20"	RTEHH606620	<input type="checkbox"/>	<input type="checkbox"/>	<input type="checkbox"/>	118.50#	1333	75	105	
	60 x 72 x 24"	RTEHH607224	<input type="checkbox"/>	<input type="checkbox"/>	<input type="checkbox"/>	135.50#	1352	75	105	
	60 x 86 x 30"	RTEHH608630	<input type="checkbox"/>	<input type="checkbox"/>	<input type="checkbox"/>	158.50#	1538	75	105	
RTEHH										
<p>Sit Height Adjustable Horseshoe Table, 20 to 33" H</p> <ul style="list-style-type: none"> Casters and glides are interchangeable Tables are designed for maximum leg spacing All corners of surface are rounded Specify casters/glides to wheelbarrow Legs adjust with screws in 1" increments Legs are factory pre-set at 29"H 	48 x 72 x 20"	RTEEH487220	<input type="checkbox"/>	<input type="checkbox"/>	<input type="checkbox"/>	109.00#	\$ 1247	\$ 77	\$ 53	
	48 x 80 x 24"	RTEEH488024	<input type="checkbox"/>	<input type="checkbox"/>	<input type="checkbox"/>	122.00#	1448	77	74	
	48 x 92 x 30"	RTEEH489230	<input type="checkbox"/>	<input type="checkbox"/>	<input type="checkbox"/>	141.00#	1448	77	74	
	60 x 66 x 20"	RTEEH606620	<input type="checkbox"/>	<input type="checkbox"/>	<input type="checkbox"/>	123.00#	1311	77	105	
	60 x 72 x 24"	RTEEH607224	<input type="checkbox"/>	<input type="checkbox"/>	<input type="checkbox"/>	140.00#	1331	77	105	
	60 x 86 x 30"	RTEEH608630	<input type="checkbox"/>	<input type="checkbox"/>	<input type="checkbox"/>	163.00#	1512	77	105	
RTEEH										
<p>Sit-Stand Height Adjustable Horseshoe Table, 29 to 42" H</p> <ul style="list-style-type: none"> Casters and glides are interchangeable Tables are designed for maximum leg spacing All corners of surface are rounded Specify casters/glides to wheelbarrow Legs adjust with screws in 1" increments Legs are factory pre-set at 29"H 	48 x 72 x 20"	RTEFH487220	<input type="checkbox"/>	<input type="checkbox"/>	<input type="checkbox"/>	113.00#	\$ 1261	\$ 88	\$ 53	
	48 x 80 x 24"	RTEFH488024	<input type="checkbox"/>	<input type="checkbox"/>	<input type="checkbox"/>	126.00#	1464	88	74	
	48 x 92 x 30"	RTEFH489230	<input type="checkbox"/>	<input type="checkbox"/>	<input type="checkbox"/>	145.00#	1464	88	74	
	60 x 66 x 20"	RTEFH606620	<input type="checkbox"/>	<input type="checkbox"/>	<input type="checkbox"/>	127.00#	1326	88	105	
	60 x 72 x 24"	RTEFH607224	<input type="checkbox"/>	<input type="checkbox"/>	<input type="checkbox"/>	144.00#	1347	88	105	
	60 x 86 x 30"	RTEFH608630	<input type="checkbox"/>	<input type="checkbox"/>	<input type="checkbox"/>	167.00#	1527	88	105	
RTEFH										

A **B** **C** **D** **E**

HOW TO ORDER

- Indicate the following information on order form:
- Quantity of each item.
 - Model number, including options. See "How To Build a Model Number".
 - Any special service required.

Note: • The indicates that a choice is required.

- The absence of the indicates that no choice is required.
- Alpha-numeric characters in place of indicate that no other alternatives are available.

HOW TO BUILD A MODEL NUMBER

- A** Select basic model/edge style.
74P - 1-1/4" laminate top w/74P edge band
- B** Select edge color.
Refer to the **Product Color Options** page in this price list.
- C** Select surface finish.
Refer to the **Product Color Options** page in this price list.
- D** Select base finish.
Refer to the **Product Color Options** page in this price list.
- E** Select base option.
- CCC** - Casters
 - BCF** - Casters/felt glides
 - BCN** - Casters/nylon glides
 - GFT** - Felt glides
 - GNV** - Nylon glides
- Base options for Floor Height Adjustable are

ONLY Felt glides - GFT and Nylon glides - GNV

FINISH INFORMATION

Additional Laminate Offering

KI offers laminates beyond those offered in the standard offering. Laminates that are currently available in the program can be viewed in KI product specification tools. Requests to add laminates to the program can be submitted via the product modification request process. Please note, requests to add laminates to the program must include the laminate manufacturer's name, color/pattern number, and finish code. Edge options are limited to standard edge colors. If a matching edge is required, this will need to be requested through the product modification request process and may be subject to additional costs. Due to varying manufacturing processes and quality issues with some laminates, some requests may be denied. Extended lead times and minimum order quantities may apply on orders containing special laminates. Contact the product modification team for questions or additional information regarding special laminates and pricing.

SPECIAL SERVICES

Special Carton Marking

With specially marked information N/C

Shipping
Ships **knocked down, FOB Bonduel, WI 54107, freight prepaid.** Freight class 70.

Specifications and prices are subject to change without prior notice.

Ruckus® Activity Table (Delivered Pricing)

1-1/4" Top - 74P Edge



Ruckus® Activity Table (Delivered Pricing)

1-1/4" Top - 74P Edge

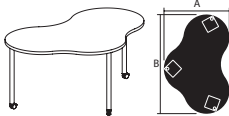
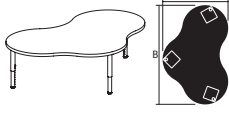
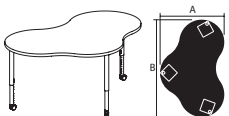
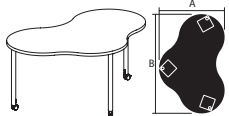
MODEL	A x B	MODEL NUMBER					Approx. Packaged Weight	Delivered Pricing	Chrome Upcharge add to list price	Laminate Grade 2 add to list price
		Basic Model/Edge Style	Edge Color	Surface Finish	Base Finish	Base Option				
 <p>Fixed Height Amoeba Table, 29" H</p> <ul style="list-style-type: none"> • Casters and glides are interchangeable • Tables are designed for maximum leg spacing • All corners of surface are rounded • Specify casters/glides to wheelbarrow 	36 x 48"	RTEAU3648-74P	<input type="checkbox"/>	<input type="checkbox"/>	<input type="checkbox"/>	<input type="checkbox"/>	65.00#	\$ 680	\$ 51	\$ 53
	43 x 65"	RTEAU4365-74P	<input type="checkbox"/>	<input type="checkbox"/>	<input type="checkbox"/>	<input type="checkbox"/>	82.00#	955	51	53
RTEAU										
 <p>Floor Height Adjustable Amoeba Table, 12 to 19" H</p> <ul style="list-style-type: none"> • Tables are designed for maximum leg spacing • All corners of surface are rounded • Legs adjust with screws in 1" increments • Legs are factory pre-set at 19"H • Base only available in glides 	36 x 48"	RTEHU3648-74P	<input type="checkbox"/>	<input type="checkbox"/>	<input type="checkbox"/>	<input type="checkbox"/>	62.00#	\$ 730	\$ 54	\$ 53
	43 x 65"	RTEHU4365-74P	<input type="checkbox"/>	<input type="checkbox"/>	<input type="checkbox"/>	<input type="checkbox"/>	80.00#	1005	54	53
RTEHU										
 <p>Sit Height Adjustable Amoeba Table, 20 to 33" H</p> <ul style="list-style-type: none"> • Casters and glides are interchangeable • Tables are designed for maximum leg spacing • All corners of surface are rounded • Specify casters/glides to wheelbarrow • Legs adjust with screws in 1" increments • Legs are factory pre-set at 29"H 	36 x 48"	RTEEU3648-74P	<input type="checkbox"/>	<input type="checkbox"/>	<input type="checkbox"/>	<input type="checkbox"/>	65.00#	\$ 733	\$ 56	\$ 53
	43 x 65"	RTEEU4365-74P	<input type="checkbox"/>	<input type="checkbox"/>	<input type="checkbox"/>	<input type="checkbox"/>	65.00#	1008	56	53
RTEEU										
 <p>Sit-Stand Height Adjustable Amoeba Table, 29 to 42" H</p> <ul style="list-style-type: none"> • Casters and glides are interchangeable • Tables are designed for maximum leg spacing • All corners of surface are rounded • Specify casters/glides to wheelbarrow • Legs adjust with screws in 1" increments • Legs are factory pre-set at 29"H 	36 x 48"	RTEFU3648-74P	<input type="checkbox"/>	<input type="checkbox"/>	<input type="checkbox"/>	<input type="checkbox"/>	69.00#	\$ 749	\$ 65	\$ 53
	43 x 65"	RTEFU4365-74P	<input type="checkbox"/>	<input type="checkbox"/>	<input type="checkbox"/>	<input type="checkbox"/>	87.00#	1024	65	53
RTEFU										

A **B** **C** **D** **E**

HOW TO ORDER

- Indicate the following information on order form:
1. Quantity of each item.
 2. Model number, including options. See "How To Build a Model Number".
 3. Any special service required.

Note: • The indicates that a choice is required.

- The absence of the indicates that no choice is required.
- Alpha-numeric characters in place of indicate that no other alternatives are available.

HOW TO BUILD A MODEL NUMBER

A Select basic model/edge style.
74P - 1-1/4" laminate top w/74P edge band

B Select edge color.
 Refer to the **Product Color Options** page in this price list.

C Select surface finish.
 Refer to the **Product Color Options** page in this price list.

D Select base finish.
 Refer to the **Product Color Options** page in this price list.

E Select base option.
CCC - Casters
BCF - Casters/felt glides
BCN - Casters/nylon glides
GFT - Felt glides
GNV - Nylon glides
 Base options for Floor Height Adjustable are

ONLY Felt glides - GFT and Nylon glides - GNV

FINISH INFORMATION

Additional Laminate Offering

KI offers laminates beyond those offered in the standard offering. Laminates that are currently available in the program can be viewed in KI product specification tools. Requests to add laminates to the program can be submitted via the product modification request process. Please note, requests to add laminates to the program must include the laminate manufacturer's name, color/pattern number, and finish code. Edge options are limited to standard edge colors. If a matching edge is required, this will need to be requested through the product modification request process and may be subject to additional costs. Due to varying manufacturing processes and quality issues with some laminates, some requests may be denied. Extended lead times and minimum order quantities may apply on orders containing special laminates. Contact the product modification team for questions or additional information regarding special laminates and pricing.

SPECIAL SERVICES

Special Carton Marking

With specially marked information N/C

Shipping

Ships **knocked down, FOB Bonduel, WI 54107, freight prepaid.** Freight class 70.

Specifications and prices are subject to change without prior notice.

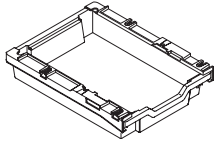
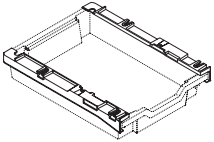

MODEL	MODEL NUMBER	Approx. Packaged Weight	Delivered Pricing
	Basic Model		
 <p>Removable Tote Storage Kit, with 3" Tote (for Ruckus desk & tables only)</p> <ul style="list-style-type: none"> Undersurface rails are transparent For Ruckus desk and tables with pre-drilled holes 	RKUSRT1	3.00#	\$ 68
	RKAU		
 <p>Removable Tote Storage Rail Only Kit (for Ruckus desk & tables only)</p> <ul style="list-style-type: none"> Undersurface rails are transparent For Ruckus desk and tables with pre-drilled holes 	RKUSRTR01	0.80#	\$ 42
	RKAU		

A

HOW TO ORDER

- Indicate the following information on order form:
- Quantity of each item.
 - Model number, including options. See "How To Build a Model Number".
 - Any special service required.

Note:

- The indicates that a choice is required.
- The absence of the indicates that no choice is required.
- Alpha-numeric characters in place of indicate that no other alternatives are available.

HOW TO BUILD A MODEL NUMBER

A Select basic model.

SPECIAL SERVICES

Special Carton Marking



With specially marked information N/C

Shipping

Ships **assembled, FOB Bonduel, WI 54107, freight prepaid.** Freight class 70.

Specifications and prices are subject to change without prior notice.



D x W x H	MODEL NUMBER											Approx. Packaged Weight	1-1/4" Laminate Top with 74P Edge (74P)	1" Phenolic Resin Top (RNT)	1-3/4" Butcher Block Wood Top (WBB)	Laminate Grade 2 add to list price	WPA1 Power Option	WPB1 Power Option		
	Basic Model	Power Option	Power Module Color	Book Bag Hook	Base Color	Top Color	Edge Color	Door Color	Pull Option	Lock Option	Lock Color									
 <p>RCWT Single-Faced 2x2 Cubby Storage, Open</p> <ul style="list-style-type: none"> • Toolless removable worksurface • Worksurface dimensions: 30x54 • Storage base dimensions: 18x30 • Unit ships partially assembled, casters and worksurface are field installed • Shown with optional power module WPA1 • Cubby spaces 14"Hx13.5"Wx17"D 	30 x 54 x 36	RCWT305436COP-74P	<input type="checkbox"/> <input type="checkbox"/> <input type="checkbox"/> <input type="checkbox"/>	<input type="checkbox"/>	<input type="checkbox"/>	<input type="checkbox"/>	<input type="checkbox"/>	<input type="checkbox"/>					134.70#	\$ 1805	N/A	N/A	\$ 27	\$ 550	\$ 682	
	30 x 54 x 35-3/4	RCWT305436COP-RNT	<input type="checkbox"/> <input type="checkbox"/> <input type="checkbox"/> <input type="checkbox"/>	<input type="checkbox"/>	<input type="checkbox"/>	<input type="checkbox"/>	<input type="checkbox"/>							162.30#	N/A	2857	N/A	N/A	580	710
	30 x 54 x 36-1/2	RCWT305436COP-WBB	<input type="checkbox"/> <input type="checkbox"/> <input type="checkbox"/> <input type="checkbox"/>	<input type="checkbox"/>	<input type="checkbox"/>	<input type="checkbox"/>	<input type="checkbox"/>							160.10#	N/A	N/A	3235	N/A	644	771
 <p>RCWT Single-Faced 2x2 Cubby Storage, With Doors</p> <ul style="list-style-type: none"> • Toolless removable worksurface • Worksurface dimensions: 30x54 • Storage base dimensions: 18x30 • Unit ships partially assembled, casters and worksurface are field installed • Shown with optional power module WPA1 • Cubby spaces 14"Hx13.5"Wx17"D • Secure locking doors 	30 x 54 x 36	RCWT305436CDR-74P	<input type="checkbox"/> <input type="checkbox"/> <input type="checkbox"/> <input type="checkbox"/>	<input type="checkbox"/>	<input type="checkbox"/>	<input type="checkbox"/>	<input type="checkbox"/>	<input type="checkbox"/>	<input type="checkbox"/>	<input type="checkbox"/>	<input type="checkbox"/>	<input type="checkbox"/>	145.70#	\$ 2161	N/A	N/A	\$ 27	\$ 550	\$ 682	
	30 x 54 x 35-3/4	RCWT305436CDR-RNT	<input type="checkbox"/> <input type="checkbox"/> <input type="checkbox"/> <input type="checkbox"/>	<input type="checkbox"/>	<input type="checkbox"/>	<input type="checkbox"/>	<input type="checkbox"/>	<input type="checkbox"/>	<input type="checkbox"/>	<input type="checkbox"/>	<input type="checkbox"/>	<input type="checkbox"/>	<input type="checkbox"/>	173.30#	N/A	3139	N/A	N/A	580	710
	30 x 54 x 36-1/2	RCWT305436CDR-WBB	<input type="checkbox"/> <input type="checkbox"/> <input type="checkbox"/> <input type="checkbox"/>	<input type="checkbox"/>	<input type="checkbox"/>	<input type="checkbox"/>	<input type="checkbox"/>	<input type="checkbox"/>	<input type="checkbox"/>	<input type="checkbox"/>	<input type="checkbox"/>	<input type="checkbox"/>	<input type="checkbox"/>	171.10#	N/A	N/A	3513	N/A	644	771
			A	B	C	D	E	F	G	H	I	J	K							

HOW TO ORDER

- Indicate the following information on order form:
- Quantity of each item.
 - Model number, including options. See "How To Build a Model Number".
 - Any special service required.

Note:

- The indicates that a choice is required.
- The absence of the indicates that no choice is required.
- Alpha-numeric characters in place of indicate that no other alternatives are available.

HOW TO BUILD A MODEL NUMBER

- A** Select basic model.
- B** Select power option.
 - NP** - No power
 - WPA1** - One above-surface module w/ USB-A/C w/wire mgmt (10ft cord)
 - WPB1** - One above-surface module w/ USB-A & Qi wireless charge w/wire mgmt (10ft cord)
 - WPB1** - One above-surface module w/ USB-A & Qi wireless charge w/wire mgmt (10ft cord)
 - WPB1** - One above-surface module w/ USB-A & Qi wireless charge w/wire mgmt (10ft cord)
- C** Select power module color.
 - P1** - Black
 - P2** - Cool Grey
- D** Select book bag hooks.
 - NB** - No book bag hook

- BH** - Two book bag hooks (chrome); add \$20
- E** Select base color. Refer to the **Product Color Options** page in this price list.
- F** Select top color. Refer to the **Product Color Options** page in this price list.
- G** Select edge color. Refer to the **Product Color Options** page in this price list.
- H** Select door color. Refer to the **Product Color Options** page in this price list.
- I** Select door pull.
 - S6** - Beveled pull Black
 - S5** - Beveled pull Satin Chrome
- J** Select lock option.
 - KS** - Key standard - 2 locks

- NLC** - No lock core - 2 locks
- K** Select lock color. Refer to the **Product Color Options** page in this price list.

SPECIAL SERVICES

Special Carton Marking
With specially marked information N/C

Shipping
Ships **partially assembled, FOB Pembroke, ON K&A 0E1, freight prepaid.** Freight class 100.

Specifications and prices are subject to change without prior notice.

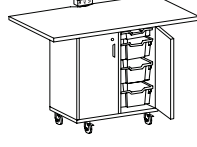

D x W x H	MODEL NUMBER											Approx. Packaged Weight	1-1/4" Laminate Top with 74P Edge (74P)	1" Phenolic Resin Top (RNT)	1-3/4" Butcher Block Wood Top (WBB)	Laminate Grade 2 add to list price	WPA1 Power Option	WPB1 Power Option	
	Basic Model	Power Option	Power Module Color	Book Bag Hook	Base Color	Top Color	Edge Color	Door Color	Pull Option	Lock Option	Lock Color								
 30 x 54 x 36	RCWT305436TOP-74P	<input type="checkbox"/>	<input type="checkbox"/>	<input type="checkbox"/>	<input type="checkbox"/>	<input type="checkbox"/>	<input type="checkbox"/>	<input type="checkbox"/>					144.90#	\$ 1969	N/A	N/A	\$ 27	\$ 550	\$ 682
30 x 54 x 35-3/4	RCWT305436TOP-RNT	<input type="checkbox"/>	<input type="checkbox"/>	<input type="checkbox"/>	<input type="checkbox"/>	<input type="checkbox"/>	<input type="checkbox"/>						172.50#	N/A	2978	N/A	N/A	580	710
30 x 54 x 36-1/2	RCWT305436TOP-WBB	<input type="checkbox"/>	<input type="checkbox"/>	<input type="checkbox"/>	<input type="checkbox"/>	<input type="checkbox"/>	<input type="checkbox"/>						170.30#	N/A	N/A	3396	N/A	644	771
RCWT Single-Faced Tote Storage, (6) 6" & (2) 3" Totes, Open																			
<ul style="list-style-type: none"> • Toolless removable worksurface • Worksurface dimensions: 30x54 • Storage base dimensions: 18x30 • Unit ships partially assembled, casters and worksurface are field installed • Shown with optional power module WPA1 • Totes included are translucent with no lid 																			
 30 x 54 x 36	RCWT305436TDR-74P	<input type="checkbox"/>	<input type="checkbox"/>	<input type="checkbox"/>	<input type="checkbox"/>	<input type="checkbox"/>	<input type="checkbox"/>	<input type="checkbox"/>	<input type="checkbox"/>	<input type="checkbox"/>	<input type="checkbox"/>	<input type="checkbox"/>	155.90#	\$ 2307	N/A	N/A	\$ 27	\$ 550	\$ 682
30 x 54 x 35-3/4	RCWT305436TDR-RNT	<input type="checkbox"/>	<input type="checkbox"/>	<input type="checkbox"/>	<input type="checkbox"/>	<input type="checkbox"/>	<input type="checkbox"/>	<input type="checkbox"/>	<input type="checkbox"/>	<input type="checkbox"/>	<input type="checkbox"/>	<input type="checkbox"/>	183.50#	N/A	3276	N/A	N/A	580	710
30 x 54 x 36-1/2	RCWT305436TDR-WBB	<input type="checkbox"/>	<input type="checkbox"/>	<input type="checkbox"/>	<input type="checkbox"/>	<input type="checkbox"/>	<input type="checkbox"/>	<input type="checkbox"/>	<input type="checkbox"/>	<input type="checkbox"/>	<input type="checkbox"/>	<input type="checkbox"/>	181.30#	N/A	N/A	3696	N/A	644	771
RCWT Single-Faced Tote Storage, (6) 6" & (2) 3" Totes, With Doors																			
<ul style="list-style-type: none"> • Toolless removable worksurface • Worksurface dimensions: 30x54 • Storage base dimensions: 18x30 • Unit ships partially assembled, casters and worksurface are field installed • Shown with optional power module WPA1 • Totes included are translucent with no lid • Secure locking doors 																			
A B C D E F G H I J K																			

HOW TO ORDER

- Indicate the following information on order form:
- Quantity of each item.
 - Model number, including options. See "How To Build a Model Number".
 - Any special service required.

Note: • The indicates that a choice is required.
 • The absence of the indicates that no choice is required.
 • Alpha-numeric characters in place of indicate that no other alternatives are available.

HOW TO BUILD A MODEL NUMBER

- A** Select basic model.
- B** Select power option.
 - NP** - No power
 - WPA1** - One above-surface module w/ USB-A/C w/wire mgmt (10ft cord)
 - WPB1** - One above-surface module w/ USB-A & Qi wireless charge w/wire mgmt (10ft cord)
 - WPB1** - One above-surface module w/ USB-A & Qi wireless charge w/wire mgmt (10ft cord)
 - WPB1** - One above-surface module w/ USB-A & Qi wireless charge w/wire mgmt (10ft cord)
- C** Select power module color.
 - P1** - Black
 - P2** - Cool Grey
- D** Select book bag hooks.
 - NB** - No book bag hook

- BH** - Two book bag hooks (chrome); add \$20
- E** Select base color. Refer to the **Product Color Options** page in this price list.
- F** Select top color. Refer to the **Product Color Options** page in this price list.
- G** Select edge color. Refer to the **Product Color Options** page in this price list.
- H** Select door color. Refer to the **Product Color Options** page in this price list.
- I** Select door pull.
 - S6** - Beveled pull Black
 - S5** - Beveled pull Satin Chrome
- J** Select lock option.
 - KS** - Key standard - 2 locks

- NLC** - No lock core - 2 locks
- K** Select lock color. Refer to the **Product Color Options** page in this price list.



SPECIAL SERVICES

Special Carton Marking
 With specially marked information N/C

Shipping
 Ships **partially assembled, FOB Pembroke, ON K8A 0E1, freight prepaid.** Freight class 100.

Specifications and prices are subject to change without prior notice.



D x W x H	MODEL NUMBER											Approx. Packaged Weight	1-1/4" Laminate Top with 74P Edge (74P)	1" Phenolic Resin Top (RNT)	1-3/4" Butcher Block Wood Top (WBB)	Laminate Grade 2 add to list price	WPC2 Power Option	
	Basic Model	Power Option	Power Module Color	Book Bag Hook	Base Color	Top Color	Edge Color	Door Color	Pull Option	Lock Option	Lock Color							
 48 x 54 x 36	RCWT485436COP-74P	<input type="checkbox"/>	<input type="checkbox"/>	<input type="checkbox"/>	<input type="checkbox"/>	<input type="checkbox"/>	<input type="checkbox"/>	<input type="checkbox"/>					249.70#	\$ 3076	N/A	N/A	\$ 53	\$ 898
48 x 54 x 35-3/4	RCWT485436COP-RNT	<input type="checkbox"/>	<input type="checkbox"/>	<input type="checkbox"/>	<input type="checkbox"/>	<input type="checkbox"/>	<input type="checkbox"/>						293.00#	N/A	4373	N/A	N/A	898
48 x 54 x 36-1/2	RCWT485436COP-WBB	<input type="checkbox"/>	<input type="checkbox"/>	<input type="checkbox"/>	<input type="checkbox"/>	<input type="checkbox"/>	<input type="checkbox"/>						290.00#	N/A	N/A	5013	N/A	898
RCWT																		
Double-faced 2x2 Cubby Storage, Open																		
<ul style="list-style-type: none"> • Toolless removable worksurface to ease relocation • Worksurface dimensions: 48x54 • Storage base dimensions: 36x30 • Unit ships partially assembled, casters and worksurface are field installed • Shown with optional power modules WPC2 • Cubby spaces 14"Hx13.5"Wx17"D 																		
 48 x 54 x 36	RCWT485436CDR-74P	<input type="checkbox"/>	<input type="checkbox"/>	<input type="checkbox"/>	<input type="checkbox"/>	<input type="checkbox"/>	<input type="checkbox"/>	<input type="checkbox"/>	<input type="checkbox"/>	<input type="checkbox"/>	<input type="checkbox"/>	<input type="checkbox"/>	271.70#	\$ 3538	N/A	N/A	\$ 53	\$ 898
48 x 54 x 35-3/4	RCWT485436CDR-RNT	<input type="checkbox"/>	<input type="checkbox"/>	<input type="checkbox"/>	<input type="checkbox"/>	<input type="checkbox"/>	<input type="checkbox"/>	<input type="checkbox"/>	<input type="checkbox"/>	<input type="checkbox"/>	<input type="checkbox"/>	<input type="checkbox"/>	315.00#	N/A	4837	N/A	N/A	898
48 x 54 x 36-1/2	RCWT485436CDR-WBB	<input type="checkbox"/>	<input type="checkbox"/>	<input type="checkbox"/>	<input type="checkbox"/>	<input type="checkbox"/>	<input type="checkbox"/>	<input type="checkbox"/>	<input type="checkbox"/>	<input type="checkbox"/>	<input type="checkbox"/>	<input type="checkbox"/>	312.00#	N/A	N/A	5562	N/A	898
RCWT																		
Double-faced 2x2 Cubby Storage, with Doors																		
<ul style="list-style-type: none"> • Toolless removable worksurface to ease relocation • Worksurface dimensions: 48x54 • Storage base dimensions: 36x30 • Unit ships partially assembled, casters and worksurface are field installed • Shown with optional power modules WPC2 • Cubby spaces 14"Hx13.5"Wx17"D • Secure locking doors 																		
A B C D E F G H I J K																		

HOW TO ORDER

- Indicate the following information on order form:
- Quantity of each item.
 - Model number, including options. See "How To Build a Model Number".
 - Any special service required.

Note: • The indicates that a choice is required.
 • The absence of the indicates that no choice is required.
 • Alpha-numeric characters in place of indicate that no other alternatives are available.

HOW TO BUILD A MODEL NUMBER

- A** Select basic model.
- B** Select power option.
 NP - No power
 WPC2 - Two under-surface modules w/ USB-A/C and wire mgmt (10ft cords)
 See upcharge column for pricing.
- C** Select power module color.
 P1 - Black
 P2 - Cool Grey
- D** Select book bag hooks.
 NB - No book bag hook
 BH - Four book bag hooks (Chrome); add \$40
- E** Select base color.
 Refer to the **Product Color Options** page in this price list.
- F** Select top color.
 Refer to the **Product Color Options** page in this price list.

- price list.
- G** Select edge color.
 Refer to the **Product Color Options** page in this price list.
 - H** Select door color.
 Refer to the **Product Color Options** page in this price list.
 - I** Select door pull.
 S6 - Beveled pull Black
 S5 - Beveled pull Satin Chrome
 - J** Select lock option.
 KS - Key standard - 4 locks
 NLC - No lock core - 4 locks
 - K** Select lock color.
 Refer to the **Product Color Options** page in this price list.



SPECIAL SERVICES

Special Carton Marking
 With specially marked information N/C

Shipping
 Ships partially assembled, FOB Pembroke, ON K&A OE1, freight prepaid. Freight class 100.

Specifications and prices are subject to change without prior notice.



D x W x H	MODEL NUMBER											Approx. Packaged Weight	1-1/4" Laminate Top with 74P Edge (74P)	1" Phenolic Resin Top (RNT)	1-3/4" Butcher Block Wood Top (WBB)	Laminate Grade 2 add to list price	WPC2 Power Option	
	Basic Model	Power Option	Power Module Color	Book Bag Hook	Base Color	Top Color	Edge Color	Door Color	Pull Option	Lock Option	Lock Color							
 RCWT Double-faced Tote Storage, (12) 6" & (4) 3" Totes, Open • Toolless removable worksurface to ease relocation • Worksurface dimensions: 48x54 • Storage base dimensions: 36x30 • Unit ships partially assembled, casters and worksurface are field installed • Shown with optional power modules WPC2 • Totes included are translucent with no lid	48 x 54 x 36	RCWT485436TOP-74P	<input type="checkbox"/>	<input type="checkbox"/>	<input type="checkbox"/>					270.10#	\$ 3319	N/A	N/A	\$ 53	\$ 898			
	48 x 54 x 35-3/4	RCWT485436TOP-RNT	<input type="checkbox"/>	<input type="checkbox"/>	<input type="checkbox"/>					313.40#	N/A	4658	N/A	N/A	898			
	48 x 54 x 36-1/2	RCWT485436TOP-WBB	<input type="checkbox"/>	<input type="checkbox"/>	<input type="checkbox"/>					310.40#	N/A	N/A	5324	N/A	898			
 RCWT Double-faced Tote Storage, (12) 6" & (4) 3" Totes, With Doors • Toolless removable worksurface to ease relocation • Worksurface dimensions: 48x54 • Storage base dimensions: 36x30 • Unit ships partially assembled, casters and worksurface are field installed • Shown with optional power modules WPC2 • Totes included are translucent with no lid • Secure locking doors	48 x 54 x 36	RCWT485436TDR-74P	<input type="checkbox"/>	<input type="checkbox"/>	<input type="checkbox"/>	<input type="checkbox"/>	<input type="checkbox"/>	292.10#	\$ 3818	N/A	N/A	\$ 53	\$ 898					
	48 x 54 x 35-3/4	RCWT485436TDR-RNT	<input type="checkbox"/>	<input type="checkbox"/>	<input type="checkbox"/>	<input type="checkbox"/>	<input type="checkbox"/>	335.40#	N/A	5144	N/A	N/A	898					
	48 x 54 x 36-1/2	RCWT485436TDR-WBB	<input type="checkbox"/>	<input type="checkbox"/>	<input type="checkbox"/>	<input type="checkbox"/>	<input type="checkbox"/>	332.40#	N/A	N/A	5879	N/A	898					
			A	B	C	D	E	F	G	H	I	J	K					

HOW TO ORDER

- Indicate the following information on order form:
- Quantity of each item.
 - Model number, including options. See "How To Build a Model Number".
 - Any special service required.

Note: • The indicates that a choice is required.
 • The absence of the indicates that no choice is required.
 • Alpha-numeric characters in place of indicate that no other alternatives are available.

HOW TO BUILD A MODEL NUMBER

- A** Select basic model.
- B** Select power option.
 NP - No power
 WPC2 - Two under-surface modules w/ USB-A/C and wire mgmt (10ft cords)
 See upcharge column for pricing.
- C** Select power module color.
 P1 - Black
 P2 - Cool Grey
- D** Select book bag hooks.
 NB - No book bag hook
 BH - Four book bag hooks (Chrome); add \$40
- E** Select base color.
 Refer to the **Product Color Options** page in this price list.
- F** Select top color.
 Refer to the **Product Color Options** page in this price list.

- price list.
- G** Select edge color.
 Refer to the **Product Color Options** page in this price list.
- H** Select door color.
 Refer to the **Product Color Options** page in this price list.
- I** Select door pull.
 S6 - Beveled pull Black
 S5 - Beveled pull Satin Chrome
- J** Select lock option.
 KS - Key standard - 4 locks
 NLC - No lock core - 4 locks
- K** Select lock color.
 Refer to the **Product Color Options** page in this price list.

SPECIAL SERVICES

Special Carton Marking
 With specially marked information N/C

Shipping
 Ships **partially assembled, FOB Pembroke, ON K&A 0E1, freight prepaid.** Freight class 100.

Specifications and prices are subject to change without prior notice.



MODEL	D x W x H	MODEL NUMBER							Approx. Packaged Weight	1-1/4" Laminate Top with 74P Edge (74P)	1" Phenolic Resin Top (RNT)	1-3/4" Butcher Block Wood Top (WBB)	Laminate Grade 2 add to list price	WPC2 Power Option
		Basic Model	Power Option	Power Module Color	Book Bag Hook	Base Color	Top Color	Edge Color						
Double-faced 2x2 Cubby & Tote Storage, (6) 6" & (2) 3" Totes, Open • Toolless removable worksurface to ease relocation • Worksurface dimensions: 48x54 • Storage base dimensions: 36x30 • Unit ships partially assembled, casters and worksurface are field installed • Shown with optional power modules WPC2 • Totes included are translucent with no lid • Cubby spaces 14"Hx13.5"Wx17"D	48 x 54 x 36	RCWT485436CTOP-74P	<input type="checkbox"/> <input type="checkbox"/> <input type="checkbox"/> <input type="checkbox"/>	<input type="checkbox"/> <input type="checkbox"/>	<input type="checkbox"/> <input type="checkbox"/>	<input type="checkbox"/> <input type="checkbox"/>	<input type="checkbox"/> <input type="checkbox"/>	<input type="checkbox"/> <input type="checkbox"/>	259.90#	\$ 3236	N/A	N/A	\$ 53	\$ 898
	48 x 54 x 35-3/4	RCWT485436CTOP-RNT	<input type="checkbox"/> <input type="checkbox"/> <input type="checkbox"/> <input type="checkbox"/>	<input type="checkbox"/> <input type="checkbox"/>	<input type="checkbox"/> <input type="checkbox"/>	<input type="checkbox"/> <input type="checkbox"/>	<input type="checkbox"/> <input type="checkbox"/>	<input type="checkbox"/> <input type="checkbox"/>	303.20#	N/A	4485	N/A	N/A	898
	48 x 54 x 36-1/2	RCWT485436CTOP-WBB	<input type="checkbox"/> <input type="checkbox"/> <input type="checkbox"/> <input type="checkbox"/>	<input type="checkbox"/> <input type="checkbox"/>	<input type="checkbox"/> <input type="checkbox"/>	<input type="checkbox"/> <input type="checkbox"/>	<input type="checkbox"/> <input type="checkbox"/>	<input type="checkbox"/> <input type="checkbox"/>	300.20#	N/A	N/A	5191	N/A	898
			A	B	C	D	E	F	G					

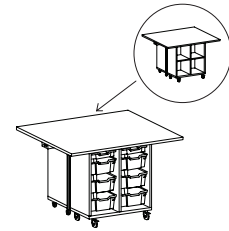

RCWT

HOW TO ORDER

- Indicate the following information on order form:
- Quantity of each item.
 - Model number, including options. See "How To Build a Model Number".
 - Any special service required.

Note: • The indicates that a choice is required.
 • The absence of the indicates that no choice is required.
 • Alpha-numeric characters in place of indicate that no other alternatives are available.

HOW TO BUILD A MODEL NUMBER

- A** Select basic model.
- B** Select power option.
NP - No power
WPC2 - Two under-surface modules w/ USB-A/C and wire mgmt (10ft cords)
 See upcharge column for pricing.
- C** Select power module color.
P1 - Black
P2 - Cool Grey
- D** Select book bag hooks.
NB - No book bag hook
BH - Four book bag hooks (Chrome); add \$40
- E** Select base color.
 Refer to the **Product Color Options** page in this price list.
- F** Select top color.
 Refer to the **Product Color Options** page in this

price list.

G Select edge color.
 Refer to the **Product Color Options** page in this price list.

SPECIAL SERVICES

Special Carton Marking
 With specially marked information N/C

Shipping
 Ships **partially assembled, FOB Pembroke, ON K8A 0E1, freight prepaid.** Freight class 100.

Specifications and prices are subject to change without prior notice.

Ruckus® Worktable (Delivered Pricing)



Ruckus® Worktable (Delivered Pricing)

D x W x H	MODEL NUMBER											Approx. Packaged Weight	 1-1/4" Laminate Top with 74P Edge (74P)	 1" Phenolic Resin Top (RNT)	 1-3/4" Butcher Block Wood Top (WBB)	 Laminate Grade 2 add to list price	 WPC2 Power Option
	Basic Model	Power Option	Power Module Color	Book Bag Hook	Base Color	Top Color	Edge Color	Door Color	Pull Option	Lock Option	Lock Color						
48 x 54 x 36	RCWT485436CTDR-74P	<input type="checkbox"/> <input type="checkbox"/> <input type="checkbox"/> <input type="checkbox"/>	<input type="checkbox"/> <input type="checkbox"/>	<input type="checkbox"/> <input type="checkbox"/>	<input type="checkbox"/> <input type="checkbox"/>		<input type="checkbox"/> <input type="checkbox"/>	<input type="checkbox"/> <input type="checkbox"/>	<input type="checkbox"/> <input type="checkbox"/>	<input type="checkbox"/> <input type="checkbox"/>	<input type="checkbox"/> <input type="checkbox"/>	281.90#	\$ 3747	N/A	N/A	\$ 53	\$ 898
48 x 54 x 35-3/4	RCWT485436CTDR-RNT	<input type="checkbox"/> <input type="checkbox"/> <input type="checkbox"/> <input type="checkbox"/>	<input type="checkbox"/> <input type="checkbox"/>	<input type="checkbox"/> <input type="checkbox"/>	<input type="checkbox"/> <input type="checkbox"/>		<input type="checkbox"/> <input type="checkbox"/>	<input type="checkbox"/> <input type="checkbox"/>	<input type="checkbox"/> <input type="checkbox"/>	<input type="checkbox"/> <input type="checkbox"/>	<input type="checkbox"/> <input type="checkbox"/>	303.20#	N/A	4970	N/A	N/A	898
48 x 54 x 36-1/2	RCWT485436CTDR-WBB	<input type="checkbox"/> <input type="checkbox"/> <input type="checkbox"/> <input type="checkbox"/>	<input type="checkbox"/> <input type="checkbox"/>	<input type="checkbox"/> <input type="checkbox"/>	<input type="checkbox"/> <input type="checkbox"/>		<input type="checkbox"/> <input type="checkbox"/>	<input type="checkbox"/> <input type="checkbox"/>	<input type="checkbox"/> <input type="checkbox"/>	<input type="checkbox"/> <input type="checkbox"/>	<input type="checkbox"/> <input type="checkbox"/>	322.20#	N/A	N/A	5745	N/A	898

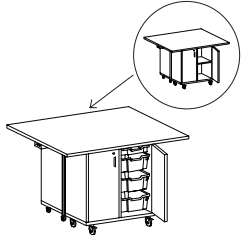

RCWT

Double-faced 2x2 Cubby & Tote Storage, (6) 6" & (2) 3" Totes, With Doors

- Toolless removable worksurface to ease relocation
- Worksurface dimensions: 48x54
- Storage base dimensions: 36x30
- Unit ships partially assembled, casters and worksurface are field installed
- Shown with optional power modules WPC2
- Totes included are translucent with no lid
- Cubby spaces 14"Hx13.5"Wx17"D
- Secure locking doors

HOW TO ORDER

- Indicate the following information on order form:
- Quantity of each item.
 - Model number, including options. See "How To Build a Model Number".
 - Any special service required.

Note: • The indicates that a choice is required.
 • The absence of the indicates that no choice is required.
 • Alpha-numeric characters in place of indicate that no other alternatives are available.

HOW TO BUILD A MODEL NUMBER

- A** Select basic model.
- B** Select power option.
 - NP** - No power
 - WPC2** - Two under-surface modules w/ USB-A/C and wire mgmt (10ft cords) See upcharge column for pricing.
- C** Select power module color.
 - P1** - Black
 - P2** - Cool Grey
- D** Select book bag hooks.
 - NB** - No book bag hook
 - BH** - Four book bag hooks (Chrome); add \$40
- E** Select base color. Refer to the **Product Color Options** page in this price list.
- F** Select top color. Refer to the **Product Color Options** page in this price list.
- G** Select edge color. Refer to the **Product Color Options** page in this price list.
- H** Select door color. Refer to the **Product Color Options** page in this price list.
- I** Select door pull.
 - S6** - Beveled pull Black
 - S5** - Beveled pull Satin Chrome
- J** Select lock option.
 - KS** - Key standard - 4 locks
 - NLC** - No lock core - 4 locks
- K** Select lock color. Refer to the **Product Color Options** page in this price list.

SPECIAL SERVICES

Special Carton Marking

With specially marked information N/C

Shipping

Ships **partially assembled, FOB Pembroke, ON K8A 0E1, freight prepaid.** Freight class 100.

Specifications and prices are subject to change without prior notice.



D x W x H	MODEL NUMBER											Approx. Packaged Weight	1-1/4" Laminate Top with 74P Edge (74P)	1" Phenolic Resin Top (RNT)	Laminate Grade 2 add to list price	WPC2 Power Option	
	Basic Model	Power Option	Power Module Color	Book Bag Hook	Base Color	Top Color	Edge Color	Door Color	Pull Option	Lock Option	Lock Color						
60 x 54 x 36	RCWT605436COP-74P	<input type="checkbox"/> <input type="checkbox"/> <input type="checkbox"/> <input type="checkbox"/>	<input type="checkbox"/> <input type="checkbox"/>	<input type="checkbox"/> <input type="checkbox"/>	<input type="checkbox"/> <input type="checkbox"/>	<input type="checkbox"/> <input type="checkbox"/>	<input type="checkbox"/> <input type="checkbox"/>	<input type="checkbox"/> <input type="checkbox"/>					270.20#	\$ 3449	N/A	\$ 53	\$ 898
60 x 54 x 35-3/4	RCWT605436COP-RNT	<input type="checkbox"/> <input type="checkbox"/> <input type="checkbox"/> <input type="checkbox"/>	<input type="checkbox"/> <input type="checkbox"/>	<input type="checkbox"/> <input type="checkbox"/>	<input type="checkbox"/> <input type="checkbox"/>	<input type="checkbox"/> <input type="checkbox"/>	<input type="checkbox"/> <input type="checkbox"/>						324.90#	N/A	4823	N/A	898
60 x 54 x 36	RCWT605436CDR-74P	<input type="checkbox"/> <input type="checkbox"/> <input type="checkbox"/> <input type="checkbox"/>	<input type="checkbox"/> <input type="checkbox"/>	<input type="checkbox"/> <input type="checkbox"/>	<input type="checkbox"/> <input type="checkbox"/>	<input type="checkbox"/> <input type="checkbox"/>	<input type="checkbox"/> <input type="checkbox"/>	<input type="checkbox"/> <input type="checkbox"/>	<input type="checkbox"/> <input type="checkbox"/>	<input type="checkbox"/> <input type="checkbox"/>	<input type="checkbox"/> <input type="checkbox"/>	<input type="checkbox"/> <input type="checkbox"/>	292.20#	\$ 3972	N/A	\$ 53	\$ 898
60 x 54 x 35-3/4	RCWT605436CDR-RNT	<input type="checkbox"/> <input type="checkbox"/> <input type="checkbox"/> <input type="checkbox"/>	<input type="checkbox"/> <input type="checkbox"/>	<input type="checkbox"/> <input type="checkbox"/>	<input type="checkbox"/> <input type="checkbox"/>	<input type="checkbox"/> <input type="checkbox"/>	<input type="checkbox"/> <input type="checkbox"/>	<input type="checkbox"/> <input type="checkbox"/>	<input type="checkbox"/> <input type="checkbox"/>	<input type="checkbox"/> <input type="checkbox"/>	<input type="checkbox"/> <input type="checkbox"/>	<input type="checkbox"/> <input type="checkbox"/>	346.90#	N/A	5319	N/A	898



RCWT
Double-faced 2x2 Cubby Storage, Open

- Toolless removable worksurface to ease relocation
- Worksurface dimensions: 60x54
- Storage base dimensions: 36x30
- Unit ships partially assembled, casters and worksurface are field installed
- Shown with optional power modules WPC2
- Cubby spaces 14"Hx13.5"Wx17"D

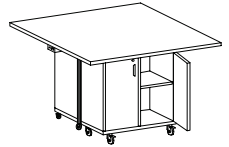

RCWT
Double-faced 2x2 Cubby Storage, with Doors

- Toolless removable worksurface to ease relocation
- Worksurface dimensions: 60x54
- Storage base dimensions: 36x30
- Unit ships partially assembled, casters and worksurface are field installed
- Shown with optional power modules WPC2
- Cubby spaces 14"Hx13.5"Wx17"D
- Secure locking doors

A B C D E F G H I J K

HOW TO ORDER

Indicate the following information on order form:
 1. Quantity of each item.
 2. Model number, including options. See "How To Build a Model Number".
 3. Any special service required.

Note: • The indicates that a choice is required.
 • The absence of the indicates that no choice is required.
 • Alpha-numeric characters in place of indicate that no other alternatives are available.

HOW TO BUILD A MODEL NUMBER

- A** Select basic model.
- B** Select power option.
NP - No power
WPC2 - Two under-surface modules w/ USB-A/C and wire mgmt (10ft cords) See upcharge column for pricing.
- C** Select power module color.
P1 - Black
P2 - Cool Grey
- D** Select book bag hooks.
NB - No book bag hook
BH - Eight book bag hooks (Chrome); add \$79
- E** Select base color. Refer to the **Product Color Options** page in this price list.
- F** Select top color. Refer to the **Product Color Options** page in this price list.

- G** Select edge color. Refer to the **Product Color Options** page in this price list.
- H** Select door color. Refer to the **Product Color Options** page in this price list.
- I** Select door pull.
S6 - Beveled pull Black
S5 - Beveled pull Satin Chrome
- J** Select lock option.
KS - Key standard - 4 locks
NLC - No lock core - 4 locks
- K** Select lock color. Refer to the **Product Color Options** page in this price list.

SPECIAL SERVICES

Special Carton Marking
 With specially marked information N/C

Shipping
 Ships partially assembled, FOB Pembroke, ON **K8A 0E1**, freight prepaid. Freight class 100.

Specifications and prices are subject to change without prior notice.



D x W x H	MODEL NUMBER											Approx. Packaged Weight	1-1/4" Laminate Top with 74P Edge (74P)	1" Phenolic Resin Top (RNT)	Laminate Grade 2 add to list price	WPC2 Power Option	
	Basic Model	Power Option	Power Module Color	Book Bag Hook	Base Color	Top Color	Edge Color	Door Color	Pull Option	Lock Option	Lock Color						
60 x 54 x 36	RCWT605436TOP-74P	<input type="checkbox"/> <input type="checkbox"/> <input type="checkbox"/> <input type="checkbox"/>	<input type="checkbox"/> <input type="checkbox"/>	<input type="checkbox"/> <input type="checkbox"/>	<input type="checkbox"/> <input type="checkbox"/>	<input type="checkbox"/> <input type="checkbox"/>	<input type="checkbox"/> <input type="checkbox"/>	<input type="checkbox"/> <input type="checkbox"/>	<input type="checkbox"/> <input type="checkbox"/>	<input type="checkbox"/> <input type="checkbox"/>	<input type="checkbox"/> <input type="checkbox"/>	<input type="checkbox"/> <input type="checkbox"/>	290.60#	\$ 3713	N/A	\$ 53	\$ 898
60 x 54 x 35-3/4	RCWT605436TOP-RNT	<input type="checkbox"/> <input type="checkbox"/> <input type="checkbox"/> <input type="checkbox"/>	<input type="checkbox"/> <input type="checkbox"/>	<input type="checkbox"/> <input type="checkbox"/>	<input type="checkbox"/> <input type="checkbox"/>	<input type="checkbox"/> <input type="checkbox"/>	<input type="checkbox"/> <input type="checkbox"/>	<input type="checkbox"/> <input type="checkbox"/>	<input type="checkbox"/> <input type="checkbox"/>	<input type="checkbox"/> <input type="checkbox"/>	<input type="checkbox"/> <input type="checkbox"/>	<input type="checkbox"/> <input type="checkbox"/>	345.30#	N/A	5142	N/A	898
<p>RCWT Double-faced Tote Storage, (12) 6" & (4) 3" Totes, Open</p> <ul style="list-style-type: none"> • Toolless removable worksurface to ease relocation • Worksurface dimensions: 60x54 • Storage base dimensions: 36x30 • Unit ships partially assembled, casters and worksurface are field installed • Shown with optional power modules WPC2 • Totes included are translucent with no lid 																	
60 x 54 x 36	RCWT605436TDR-74P	<input type="checkbox"/> <input type="checkbox"/> <input type="checkbox"/> <input type="checkbox"/>	<input type="checkbox"/> <input type="checkbox"/>	<input type="checkbox"/> <input type="checkbox"/>	<input type="checkbox"/> <input type="checkbox"/>	<input type="checkbox"/> <input type="checkbox"/>	<input type="checkbox"/> <input type="checkbox"/>	<input type="checkbox"/> <input type="checkbox"/>	<input type="checkbox"/> <input type="checkbox"/>	<input type="checkbox"/> <input type="checkbox"/>	<input type="checkbox"/> <input type="checkbox"/>	<input type="checkbox"/> <input type="checkbox"/>	312.60#	\$ 4225	N/A	\$ 53	\$ 898
60 x 54 x 35-3/4	RCWT605436TDR-RNT	<input type="checkbox"/> <input type="checkbox"/> <input type="checkbox"/> <input type="checkbox"/>	<input type="checkbox"/> <input type="checkbox"/>	<input type="checkbox"/> <input type="checkbox"/>	<input type="checkbox"/> <input type="checkbox"/>	<input type="checkbox"/> <input type="checkbox"/>	<input type="checkbox"/> <input type="checkbox"/>	<input type="checkbox"/> <input type="checkbox"/>	<input type="checkbox"/> <input type="checkbox"/>	<input type="checkbox"/> <input type="checkbox"/>	<input type="checkbox"/> <input type="checkbox"/>	<input type="checkbox"/> <input type="checkbox"/>	367.30#	N/A	5616	N/A	898
<p>RCWT Double-faced Tote Storage, (12) 6" & (4) 3" Totes, With Doors</p> <ul style="list-style-type: none"> • Toolless removable worksurface to ease relocation • Worksurface dimensions: 60x54 • Storage base dimensions: 36x30 • Unit ships partially assembled, casters and worksurface are field installed • Shown with optional power modules WPC2 • Totes included are translucent with no lid • Secure locking doors 																	
		A	B	C	D	E	F	G	H	I	J	K					

HOW TO ORDER

- Indicate the following information on order form:
- Quantity of each item.
 - Model number, including options. See "How To Build a Model Number".
 - Any special service required.

Note: • The indicates that a choice is required.

- The absence of the indicates that no choice is required.
- Alpha-numeric characters in place of indicate that no other alternatives are available.

HOW TO BUILD A MODEL NUMBER

- A** Select basic model.
- B** Select power option.
NP - No power
WPC2 - Two under-surface modules w/ USB-A/C and wire mgmt (10ft cords)
 See upcharge column for pricing.
- C** Select power module color.
P1 - Black
P2 - Cool Grey
- D** Select book bag hooks.
NB - No book bag hook
BH - Eight book bag hooks (Chrome); add \$79
- E** Select base color.
 Refer to the **Product Color Options** page in this price list.
- F** Select top color.
 Refer to the **Product Color Options** page in this

- price list.
- G** Select edge color.
 Refer to the **Product Color Options** page in this price list.
 - H** Select door color.
 Refer to the **Product Color Options** page in this price list.
 - I** Select door pull.
S6 - Beveled pull Black
S5 - Beveled pull Satin Chrome
 - J** Select lock option.
KS - Key standard - 4 locks
NLC - No lock core - 4 locks
 - K** Select lock color.
 Refer to the **Product Color Options** page in this price list.

SPECIAL SERVICES

Special Carton Marking
 With specially marked information N/C

Shipping
 Ships **partially assembled, FOB Pembroke, ON K8A 0E1, freight prepaid.** Freight class 100.

Specifications and prices are subject to change without prior notice.



MODEL	D x W x H	MODEL NUMBER							Approx. Packaged Weight	1-1/4" Laminate Top with 74P Edge (74P)	1" Phenolic Resin Top (RNT)	Laminate Grade 2 add to list price	WPC2 Power Option
		Basic Model	Power Option	Power Module Color	Book Bag Hook	Base Color	Top Color	Edge Color					
Double-faced 2x2 Cubby and Tote Storage, (6) 6" & (2) 3" Totes, Open • Toolless removable worksurface to ease relocation • Worksurface dimensions: 60x54 • Storage base dimensions: 36x30 • Unit ships partially assembled, casters and worksurface are field installed • Shown with optional power modules WPC2 • Totes included are translucent with no lid • Cubby spaces 14"Hx13.5"Wx17"D	60 x 54 x 36	RCWT605436CTOP-74P	<input type="checkbox"/> <input type="checkbox"/> <input type="checkbox"/> <input type="checkbox"/>	<input type="checkbox"/> <input type="checkbox"/>	<input type="checkbox"/> <input type="checkbox"/>	<input type="checkbox"/> <input type="checkbox"/>	<input type="checkbox"/> <input type="checkbox"/>	<input type="checkbox"/> <input type="checkbox"/>	280.40#	\$ 3583	N/A	\$ 53	\$ 898
	60 x 54 x 35-3/4	RCWT605436CTOP-RNT	<input type="checkbox"/> <input type="checkbox"/> <input type="checkbox"/> <input type="checkbox"/>	<input type="checkbox"/> <input type="checkbox"/>	<input type="checkbox"/> <input type="checkbox"/>	<input type="checkbox"/> <input type="checkbox"/>	<input type="checkbox"/> <input type="checkbox"/>	<input type="checkbox"/> <input type="checkbox"/>	335.10#	N/A	4960	N/A	898

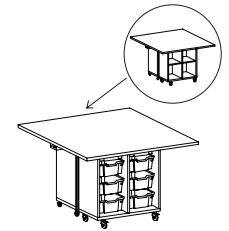

RCWT

HOW TO ORDER

- Indicate the following information on order form:
- Quantity of each item.
 - Model number, including options. See "How To Build a Model Number".
 - Any special service required.

Note: • The indicates that a choice is required.
 • The absence of the indicates that no choice is required.
 • Alpha-numeric characters in place of indicate that no other alternatives are available.

HOW TO BUILD A MODEL NUMBER

- A** Select basic model.
- B** Select power option.
 NP - No power
 WPC2 - Two under-surface modules w/ USB-A/C and wire mgmt (10ft cords)
 See upcharge column for pricing.
- C** Select power module color.
 P1 - Black
 P2 - Cool Grey
- D** Select book bag hooks.
 NB - No book bag hook
 BH - Eight book bag hooks (Chrome); add \$79
- E** Select base color.
 Refer to the **Product Color Options** page in this price list.
- F** Select top color.
 Refer to the **Product Color Options** page in this

price list.

G Select edge color.
 Refer to the **Product Color Options** page in this price list.

SPECIAL SERVICES

Special Carton Marking



With specially marked information N/C

Shipping

Ships **partially assembled, FOB Pembroke, ON K8A 0E1, freight prepaid.** Freight class 100.

Specifications and prices are subject to change without prior notice.

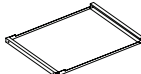
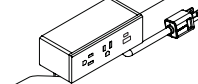
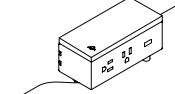
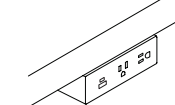

MODEL	MODEL NUMBER			Approx. Packaged Weight	Delivered Pricing
	Basic Model	Paint Color	Finish		
 Tote Storage Removeable Steel Shelf with Rail Set RCKA	RKATSSHELF	<input type="checkbox"/>	<input type="checkbox"/>	4.50#	\$ 59
 Above-surface power module w/ USB charging, 10' cord and wire management RCWA	RCWAPA1	<input type="checkbox"/>	<input type="checkbox"/>	3.00#	\$ 550
 Above-surface power module w/ USB and Qi wireless charging, 10' cord and wire management RCWA	RCWAPB1	<input type="checkbox"/>	<input type="checkbox"/>	3.00#	\$ 682
 Undersurface power module w/ USB charging, 10' cord and wire management RCWA	RCWAPC1	<input type="checkbox"/>	<input type="checkbox"/>	3.00#	\$ 496
 Ruckus Book Bag Hook RUA01	RCWABBH1			3.00#	\$ 11

A **B** **C**

HOW TO ORDER

- Indicate the following information on order form:
- Quantity of each item.
 - Model number, including options. See "How To Build a Model Number".
 - Any special service required.

Note:

- The indicates that a choice is required.
- The absence of the indicates that no choice is required.
- Alpha-numeric characters in place of indicate that no other alternatives are available.

HOW TO BUILD A MODEL NUMBER

- A** Select basic model.
- B** Select paint color. Refer to the **Product Color Options** page in this price list.
- C** Select finish. Refer to the **Product Color Options** page in this price list.

SPECIAL SERVICES

Special Carton Marking



With specially marked information N/C

Shipping

Ships assembled, FOB Pembroke, ON K8A 0E1, freight prepaid. Freight class 100.

Specifications and prices are subject to change without prior notice.



MODEL	W x D x H	MODEL NUMBER					Approx. Packaged Weight	Delivered Pricing	Laminate Grade 2 add to list price
		Basic Model	Base	Top Color	Edge Color	Shell Color			
 <p>Single-Face Bookcase Unit with Adjustable Shelves</p> <ul style="list-style-type: none"> Laminate top (1-1/4" with 74P edge) Single sided storage 3 compartments per side (3 total) Unit ships assembled; glides/casters are field installed Shelves adjust in 1" increments, without tools 	36 x 18 x 36"	RKB361836	<input type="checkbox"/>	<input type="checkbox"/>	<input type="checkbox"/>	81.7#	\$ 1320	\$ 19	
	36 x 18 x 42"	RKB361842	<input type="checkbox"/>	<input type="checkbox"/>	<input type="checkbox"/>	89.7#	1377	19	
 <p>Double-Face Bookcase Unit with Adjustable Shelves</p> <ul style="list-style-type: none"> Laminate top (1-1/4" with 74P edge) Dual sided storage 3 compartments per side (6 total) Unit ships assembled; glides/casters are field installed Shelves adjust in 1" increments, without tools 	36 x 24 x 36"	RKB362436	<input type="checkbox"/>	<input type="checkbox"/>	<input type="checkbox"/>	161.0#	\$ 1455	\$ 19	
	36 x 24 x 42"	RKB362442	<input type="checkbox"/>	<input type="checkbox"/>	<input type="checkbox"/>	170.6#	1528	19	

A B C D E

HOW TO ORDER

- Indicate the following information on order form:
- Quantity of each item.
 - Model number, including options. See "How To Build a Model Number".
 - Any special service required.

Note:

- The indicates that a choice is required.
- The absence of the indicates that no choice is required.
- Alpha-numeric characters in place of indicate that no other alternatives are available.

HOW TO BUILD A MODEL NUMBER

- A** Select basic model.
- B** Select base option.

4CW	- 4 black casters
4GB	- 4 black glides
- C** Select top laminate surface. Refer to the **Product Color Options** page in this price list.
- D** Select edge color. Refer to the **Product Color Options** page in this price list.
- E** Select shell color. Refer to the **Product Color Options** page in this price list.

FINISH INFORMATION

Additional Laminate Offering
 KI offers laminates beyond those offered in the standard offering. Laminates that are currently available in the program can be viewed in KI product specification tools. Requests to add laminates to the program can be submitted via the product modification request process. Please note, requests to add laminates to the program must include the laminate manufacturer's name, color/pattern number, and finish code. Edge options are limited to standard edge colors. If a matching edge is required, this will need to be requested through the product modification request process and may be subject to additional costs. Due to varying manufacturing processes and quality issues with some laminates, some requests may be denied. Extended lead times and minimum order quantities may apply on orders containing special laminates. Contact the product modification team for questions or additional information regarding special laminates and pricing.

SPECIAL SERVICES

Special Carton Marking

With specially marked information N/C

Shipping
 Ships assembled, FOB Pembroke, ON K8A 0E1, freight prepaid. Freight class 100.

Specifications and prices are subject to change without prior notice.

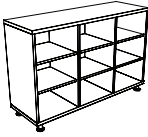
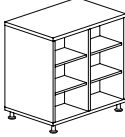
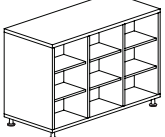

MODEL	W x D x H	MODEL NUMBER					Approx. Packaged Weight	Delivered Pricing
		Basic Model	Base	Top Color	Edge Color	Shell Color		
 Single-Face Cubbies 2x3-Open Units • Laminate top (1-1/4" with 74P edge) • Single sided storage (6 total compartments) • Unit ships assembled; glides/casters are field installed	36 x 18 x 36"	RKC361836OP	<input type="checkbox"/>	<input type="checkbox"/>	<input type="checkbox"/>	<input type="checkbox"/>	96.6#	\$ 1541
	36 x 18 x 42"	RKC361842OP	<input type="checkbox"/>	<input type="checkbox"/>	<input type="checkbox"/>	<input type="checkbox"/>	107.3#	1570
RCKC								
 Single-Face Cubbies 3x3-Open Units • Laminate top (1-1/4" with 74P edge) • Single sided storage (9 total compartments) • Unit ships assembled; glides/casters are field installed	54 x 18 x 36"	RKC541836OP	<input type="checkbox"/>	<input type="checkbox"/>	<input type="checkbox"/>	<input type="checkbox"/>	138.4#	\$ 1974
	54 x 18 x 42"	RKC541842OP	<input type="checkbox"/>	<input type="checkbox"/>	<input type="checkbox"/>	<input type="checkbox"/>	150.0#	2039
RCKC								
 Double-Face Cubbies 2x3-Open Units • Laminate top (1-1/4" with 74P edge) • Dual sided storage (12 total compartments) • Unit ships assembled; glides/casters are field installed	36 x 24 x 36"	RKC362436OP	<input type="checkbox"/>	<input type="checkbox"/>	<input type="checkbox"/>	<input type="checkbox"/>	181.4#	\$ 1705
	36 x 24 x 42"	RKC362442OP	<input type="checkbox"/>	<input type="checkbox"/>	<input type="checkbox"/>	<input type="checkbox"/>	194.6#	1767
RCKC								
 Double-Face Cubbies 3x3-Open Units • Laminate top (1-1/4" with 74P edge) • Dual sided storage (18 total compartments) • Unit ships assembled; glides/casters are field installed	54 x 24 x 36"	RKC542436OP	<input type="checkbox"/>	<input type="checkbox"/>	<input type="checkbox"/>	<input type="checkbox"/>	235.2#	\$ 2222
	54 x 24 x 42"	RKC542442OP	<input type="checkbox"/>	<input type="checkbox"/>	<input type="checkbox"/>	<input type="checkbox"/>	253.1#	2303
RCKC								

A **B** **C** **D** **E**

HOW TO ORDER

- Indicate the following information on order form:
- Quantity of each item.
 - Model number, including options. See "How To Build a Model Number".
 - Any special service required.

Note: • The indicates that a choice is required.
 • The absence of the indicates that no choice is required.
 • Alpha-numeric characters in place of indicate that no other alternatives are available.

HOW TO BUILD A MODEL NUMBER

- A** Select basic model.
- B** Select base option.

4CW	- 4 black casters
4GB	- 4 black glides
- C** Select top laminate surface.
 Refer to the **Product Color Options** page in this price list.
- D** Select edge color.
 Refer to the **Product Color Options** page in this price list.
- E** Select shell color.
 Refer to the **Product Color Options** page in this price list.

FINISH INFORMATION

Additional Laminate Offering
 KI offers laminates beyond those offered in the standard offering. Laminates that are currently available in the program can be viewed in KI product specification tools. Requests to add laminates to the program can be submitted via the product modification request process. Please note, requests to add laminates to the program must include the laminate manufacturer's name, color/pattern number, and finish code. Edge options are limited to standard edge colors. If a matching edge is required, this will need to be requested through the product modification request process and may be subject to additional costs. Due to varying manufacturing processes and quality issues with some laminates, some requests may be denied. Extended lead times and minimum order quantities may apply on orders containing special laminates. Contact the product modification team for questions or additional information regarding special laminates and pricing.

SPECIAL SERVICES

Special Carton Marking

With specially marked information N/C

Shipping
 Ships assembled, FOB Pembroke, ON K8A 0E1, freight prepaid. Freight class 100.

Specifications and prices are subject to change without prior notice.

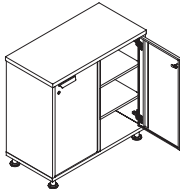
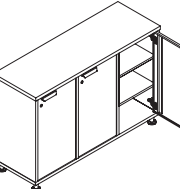

W x D x H	MODEL NUMBER										Approx. Packaged Weight	Delivered Pricing Standard Lock	Laminate Grade 2 add to list price
	Basic Model	Door Lock Option	Pull Option	Base	Top Color	Edge Color	Shell Color	Door Color	Lock Option	Lock Color			
36 x 18 x 36"	RKC361836DR	<input type="checkbox"/> <input type="checkbox"/> <input type="checkbox"/> <input type="checkbox"/> <input type="checkbox"/>	<input type="checkbox"/>	<input type="checkbox"/> <input type="checkbox"/>	<input type="checkbox"/> <input type="checkbox"/>	<input type="checkbox"/> <input type="checkbox"/>	<input type="checkbox"/>	<input type="checkbox"/> <input type="checkbox"/>	<input type="checkbox"/>	<input type="checkbox"/> <input type="checkbox"/>	114.40#	\$ 1984	\$ 19
36 x 18 x 42"	RKC361842DR	<input type="checkbox"/> <input type="checkbox"/> <input type="checkbox"/> <input type="checkbox"/> <input type="checkbox"/>	<input type="checkbox"/>	<input type="checkbox"/> <input type="checkbox"/>	<input type="checkbox"/> <input type="checkbox"/>	<input type="checkbox"/> <input type="checkbox"/>	<input type="checkbox"/>	<input type="checkbox"/> <input type="checkbox"/>	<input type="checkbox"/>	<input type="checkbox"/> <input type="checkbox"/>	128.10#	2026	19
 <p>RKC361836DR / RKC361842DR</p> <p>RCKC Single-Face Cubbies 2x3-With Doors</p> <ul style="list-style-type: none"> Laminate top (1-1/4" with 74P edge) Single sided storage (6 total compartments) Secure locking doors Unit ships assembled; glides/casters are field installed 													
54 x 18 x 36"	RKC541836DR	<input type="checkbox"/> <input type="checkbox"/> <input type="checkbox"/> <input type="checkbox"/> <input type="checkbox"/>	<input type="checkbox"/>	<input type="checkbox"/> <input type="checkbox"/>	<input type="checkbox"/> <input type="checkbox"/>	<input type="checkbox"/> <input type="checkbox"/>	<input type="checkbox"/>	<input type="checkbox"/> <input type="checkbox"/>	<input type="checkbox"/>	<input type="checkbox"/> <input type="checkbox"/>	161.70#	\$ 2555	\$ 19
54 x 18 x 42"	RKC541842DR	<input type="checkbox"/> <input type="checkbox"/> <input type="checkbox"/> <input type="checkbox"/> <input type="checkbox"/>	<input type="checkbox"/>	<input type="checkbox"/> <input type="checkbox"/>	<input type="checkbox"/> <input type="checkbox"/>	<input type="checkbox"/> <input type="checkbox"/>	<input type="checkbox"/>	<input type="checkbox"/> <input type="checkbox"/>	<input type="checkbox"/>	<input type="checkbox"/> <input type="checkbox"/>	180.70#	2617	19
 <p>RKC541836DR / RKC541842DR</p> <p>RCKC Single-Face Cubbies 3x3-With Doors</p> <ul style="list-style-type: none"> Laminate top (1-1/4" with 74P edge) Single sided storage (9 total compartments) Secure locking doors Unit ships assembled; glides/casters are field installed 													

A **B** **C** **D** **E** **F** **G** **H** **I** **J**

HOW TO ORDER

- Indicate the following information on order form:
- Quantity of each item.
 - Model number, including options. See "How To Build a Model Number".
 - Any special service required.

Note: • The indicates that a choice is required.
• The absence of the indicates that no choice is required.
• Alpha-numeric characters in place of indicate that no other alternatives are available.

HOW TO BUILD A MODEL NUMBER

- A** Select basic model.
- B** Select door lock option.

SLCKL	- Standard lock hinged left
SLCKR	- Standard lock hinged right
- C** Select pull option.

S6	- Beveled pull Black
S5	- Beveled pull Satin Chrome

 Pull selection only when SLCKR or SLCKL key lock is selected.
- D** Select base option.

4CW	- 4 black casters
4GB	- 4 black glides
- E** Select top laminate surface.
Refer to the **Product Color Options** page in this price list.
- F** Select edge color.
Refer to the **Product Color Options** page in this price list.
- G** Select shell color.
Refer to the **Product Color Options** page in this price list.
- H** Select front door color.
Refer to the **Product Color Options** page in this price list.
- I** Select lock option

KS	- Key standard - 2 locks
KS	- Key standard - 3 locks
NLC	- No lock core - 2 locks
NLC	- No lock core - 3 locks
- J** Select lock color.
Refer to the **Product Color Options** page in this price list.

FINISH INFORMATION

Additional Laminate Offering
Additional laminates beyond KI standard offering, are available with two weeks extended leadtime. To specify additional laminates, use these designators followed by the supplier's color/pattern code:

Formica - LF/supplier's color pattern code
Nevamar - LN/supplier's color pattern code
Wilsonart - LW/supplier's color pattern code

KI's standard finish is the supplier's recommended finish for that color/pattern. Note: Nonstandard laminates from these suppliers (example: textured laminates), require an upcharge and additional leadtime. Contact KI.

SPECIAL SERVICES

Special Carton Marking
With specially marked information N/C

Shipping
Ships assembled, FOB Pembroke, ON K8A 0E1, freight prepaid. Freight class 100.

Specifications and prices are subject to change without prior notice.



W x D x H	MODEL NUMBER										Approx. Packaged Weight	Delivered Pricing Standard Lock	Laminate Grade 2 add to list price	
	Basic Model	Door Lock Option	Pull Option	Base	Top Color	Edge Color	Shell Color	Door Color	Lock Option	Lock Color				
36 x 24 x 36"	RKC362436DR	<input type="checkbox"/> <input type="checkbox"/> <input type="checkbox"/> <input type="checkbox"/> <input type="checkbox"/>	<input type="checkbox"/>	<input type="checkbox"/> <input type="checkbox"/>	<input type="checkbox"/> <input type="checkbox"/>	<input type="checkbox"/> <input type="checkbox"/>	<input type="checkbox"/> <input type="checkbox"/>	<input type="checkbox"/> <input type="checkbox"/>	<input type="checkbox"/> <input type="checkbox"/>	<input type="checkbox"/> <input type="checkbox"/>	<input type="checkbox"/> <input type="checkbox"/>	208.20#	\$ 2229	\$ 19
36 x 24 x 42"	RKC362442DR	<input type="checkbox"/> <input type="checkbox"/> <input type="checkbox"/> <input type="checkbox"/> <input type="checkbox"/>	<input type="checkbox"/>	<input type="checkbox"/> <input type="checkbox"/>	<input type="checkbox"/> <input type="checkbox"/>	<input type="checkbox"/> <input type="checkbox"/>	<input type="checkbox"/> <input type="checkbox"/>	<input type="checkbox"/> <input type="checkbox"/>	<input type="checkbox"/> <input type="checkbox"/>	<input type="checkbox"/> <input type="checkbox"/>	<input type="checkbox"/> <input type="checkbox"/>	226.00#	2303	19
<p>RKC362436DR / RKC362442DR (hinged right shown)</p> <p>RCKC Double-Face Cubbies 2x3-With Doors</p> <ul style="list-style-type: none"> Laminate top (1-1/4" with 74P edge) Dual sided storage (12 total compartments) Secure locking doors Unit ships assembled; glides/casters are field installed 														
54 x 24 x 36"	RKC542436DR	<input type="checkbox"/> <input type="checkbox"/> <input type="checkbox"/> <input type="checkbox"/> <input type="checkbox"/>	<input type="checkbox"/>	<input type="checkbox"/> <input type="checkbox"/>	<input type="checkbox"/> <input type="checkbox"/>	<input type="checkbox"/> <input type="checkbox"/>	<input type="checkbox"/> <input type="checkbox"/>	<input type="checkbox"/> <input type="checkbox"/>	<input type="checkbox"/> <input type="checkbox"/>	<input type="checkbox"/> <input type="checkbox"/>	<input type="checkbox"/> <input type="checkbox"/>	275.40#	\$ 2965	\$ 27
54 x 24 x 42"	RKC542442DR	<input type="checkbox"/> <input type="checkbox"/> <input type="checkbox"/> <input type="checkbox"/> <input type="checkbox"/>	<input type="checkbox"/>	<input type="checkbox"/> <input type="checkbox"/>	<input type="checkbox"/> <input type="checkbox"/>	<input type="checkbox"/> <input type="checkbox"/>	<input type="checkbox"/> <input type="checkbox"/>	<input type="checkbox"/> <input type="checkbox"/>	<input type="checkbox"/> <input type="checkbox"/>	<input type="checkbox"/> <input type="checkbox"/>	<input type="checkbox"/> <input type="checkbox"/>	300.30#	3065	27
<p>RKC542436DR / RKC542442DR (hinged right shown)</p> <p>RCKC Double-Face Cubbies 3x3-With Doors</p> <ul style="list-style-type: none"> Laminate top (1-1/4" with 74P edge) Dual sided storage (18 total compartments) Secure locking doors Unit ships assembled; glides/casters are field installed 														

A **B** **C** **D** **E** **F** **G** **H** **I** **J**

HOW TO ORDER

- Indicate the following information on order form:
- Quantity of each item.
 - Model number, including options. See "How To Build a Model Number".
 - Any special service required.

Note: • The indicates that a choice is required.
• The absence of the indicates that no choice is required.
• Alpha-numeric characters in place of indicate that no other alternatives are available.

HOW TO BUILD A MODEL NUMBER

- A** Select basic model.
- B** Select door lock option.

SLCKL	- Standard lock hinged left
SLCKR	- Standard lock hinged right
- C** Select pull option.

S6	- Beveled pull Black
S5	- Beveled pull Satin Chrome

 Pull selection only when SLCKR or SLCKL key lock is selected.
- D** Select base option.

4CW	- 4 black casters
4GB	- 4 black glides
- E** Select top laminate surface.
Refer to the **Product Color Options** page in this price list.
- F** Select edge color.
Refer to the **Product Color Options** page in this price list.
- G** Select shell color.
Refer to the **Product Color Options** page in this price list.
- H** Select front door color.
Refer to the **Product Color Options** page in this price list.
- I** Select lock option

KS	- Key standard - 4 locks
KS	- Key standard - 6 locks
NLC	- No lock core - 4 locks
NLC	- No lock core - 6 locks
- J** Select lock color.
Refer to the **Product Color Options** page in this price list.

FINISH INFORMATION

Additional Laminate Offering
Additional laminates beyond KI standard offering, are available with two weeks extended leadtime. To specify additional laminates, use these designators followed by the supplier's color/pattern code:

Formica - LF/supplier's color pattern code
 Nevamar - LN/supplier's color pattern code
 Wilsonart - LW/supplier's color pattern code

KI's standard laminate finish is the supplier's recommended finish for that color/pattern. Note: Nonstandard laminates from these suppliers (example: textured laminates) require a Product Modification Request. Contact customer service for details.



SPECIAL SERVICES

Special Carton Marking
With specially marked information N/C

Shipping
Ships assembled, FOB Pembroke, ON K8A 0E1, freight prepaid. Freight class 100.

Specifications and prices are subject to change without prior notice.

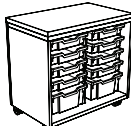
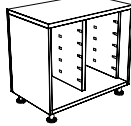

MODEL	W x D x H	MODEL NUMBER			Approx. Packaged Weight	Delivered Pricing
		Basic Model	Base	Shell Color		
 RCKT Short 2-Column Unit, Open with (12)3" Totes • Single-Face only • Totes included are translucent with no lid (not included on the 'empty' model) • Unit ships assembled, including totes and rail sets; glides/casters are field installed	30 x 18 x 27-3/4"	RKT3018280P/3T	<input type="checkbox"/> <input type="checkbox"/> <input type="checkbox"/>	<input type="checkbox"/> <input type="checkbox"/>	87.8#	\$ 1457
 RCKT Short 2-Column Unit, Open with (6)6" Totes • Single-Face only • Totes included are translucent with no lid (not included on the 'empty' model) • Unit ships assembled, including totes and rail sets; glides/casters are field installed	30 x 18 x 27-3/4"	RKT3018280P/6T	<input type="checkbox"/> <input type="checkbox"/> <input type="checkbox"/>	<input type="checkbox"/> <input type="checkbox"/>	83.9#	\$ 1353
 RCKT Short 2-Column Unit, Open with (8)3" and (2)6" Totes • Single-Face only • Totes included are translucent with no lid (not included on the 'empty' model) • Unit ships assembled, including totes and rail sets; glides/casters are field installed	30 x 18 x 27-3/4"	RKT3018280P/36T	<input type="checkbox"/> <input type="checkbox"/> <input type="checkbox"/>	<input type="checkbox"/> <input type="checkbox"/>	86.5#	\$ 1436
 RCKT Short 2-Column Unit, Open-Empty • Single-Face only • Tote and rail sets must be ordered separately and installed on-site • Unit ships assembled; glides/casters are field installed	30 x 18 x 27-3/4"	RKT3018280P/XT	<input type="checkbox"/> <input type="checkbox"/> <input type="checkbox"/>	<input type="checkbox"/> <input type="checkbox"/>	74.0#	\$ 1156

A **B** **C**

HOW TO ORDER

- Indicate the following information on order form:
- Quantity of each item.
 - Model number, including options. See "How To Build a Model Number".
 - Any special service required.

Note: • The indicates that a choice is required.
 • The absence of the indicates that no choice is required.
 • Alpha-numeric characters in place of indicate that no other alternatives are available.

HOW TO BUILD A MODEL NUMBER

- A** Select basic model.
- B** Select base option.
4CW - 4 black casters
4GB - 4 black glides
- C** Select shell color.
 Refer to the **Product Color Options** page in this price list.

SPECIAL SERVICES

Special Carton Marking



With specially marked information N/C

Shipping

Ships **assembled, FOB Pembroke, ON K8A 0E1, freight prepaid.** Freight class 100.

Specifications and prices are subject to change without prior notice.

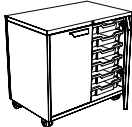

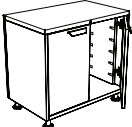
MODEL	W x D x H	MODEL NUMBER							Approx. Packaged Weight	Delivered Pricing
		Basic Model	Pull Option	Base	Shell Color	Door Color	Lock Option	Lock Color		
 RCKT Short 2-Column Unit with Doors and (12)3” Totes • Single-Face only • Totes included are translucent with no lid (not included on the 'empty' model) • Unit ships assembled, including totes and rail sets; glides/casters are field installed • Secure locking doors	30 x 18 x 27-3/4”	RKT301828DR/3T	<input type="checkbox"/>	<input type="checkbox"/>	<input type="checkbox"/>	<input type="checkbox"/>	<input type="checkbox"/>	<input type="checkbox"/>	112.1#	\$ 1719
 RCKT Short 2-Column Unit with Doors and (6)6” Totes • Single-Face only • Totes included are translucent with no lid (not included on the 'empty' model) • Unit ships assembled, including totes and rail sets; glides/casters are field installed • Secure locking doors	30 x 18 x 27-3/4”	RKT301828DR/6T	<input type="checkbox"/>	<input type="checkbox"/>	<input type="checkbox"/>	<input type="checkbox"/>	<input type="checkbox"/>	<input type="checkbox"/>	108.3#	\$ 1616
 RCKT Short 2-Column Unit with Doors and (8)3” and (2)6” Totes • Single-Face only • Totes included are translucent with no lid (not included on the 'empty' model) • Unit ships assembled, including totes and rail sets; glides/casters are field installed • Secure locking doors	30 x 18 x 27-3/4”	RKT301828DR/36T	<input type="checkbox"/>	<input type="checkbox"/>	<input type="checkbox"/>	<input type="checkbox"/>	<input type="checkbox"/>	<input type="checkbox"/>	110.8#	\$ 1699
 RCKT Short 2-Column Unit with Doors-Empty • Single-Face only • Tote and rail sets must be ordered separately and installed on-site • Unit ships assembled; glides/casters are field installed • Secure locking doors	30 x 18 x 27-3/4”	RKT301828DR/XT	<input type="checkbox"/>	<input type="checkbox"/>	<input type="checkbox"/>	<input type="checkbox"/>	<input type="checkbox"/>	<input type="checkbox"/>	98.3#	\$ 1418

A **B** **C** **D** **E** **F** **G**

HOW TO ORDER

- Indicate the following information on order form:
- Quantity of each item.
 - Model number, including options. See “How To Build a Model Number”.
 - Any special service required.

Note: • The indicates that a choice is required.
 • The absence of the indicates that no choice is required.
 • Alpha-numeric characters in place of indicate that no other alternatives are available.

HOW TO BUILD A MODEL NUMBER

Refer to the **Product Color Options** page in this price list.

- A** Select basic model.
- B** Select pull option.
 S6 - Beveled pull Black
 S5 - Beveled pull Satin Chrome
- C** Select base option.
 4CW - 4 black casters
 4GB - 4 black glides
- D** Select shell color.
 Refer to the **Product Color Options** page in this price list.
- E** Select front door color.
 Refer to the **Product Color Options** page in this price list.
- F** Select lock option.
 KS - Key standard - 2 locks
 NLC - No lock core - 2 locks
- G** Select lock color.

SPECIAL SERVICES

Special Carton Marking

With specially marked information N/C

Shipping
 Ships assembled, FOB Pembroke, ON K8A 0E1, freight prepaid. Freight class 100.

Specifications and prices are subject to change without prior notice.



	MODEL	W x D x H	MODEL NUMBER			Approx. Packaged Weight	Delivered Pricing
			Basic Model	Base	Shell Color		
	Short 3-Column Unit, Open with (18) 3\" Totes • Single-Face only • Totes included are translucent with no lid (not included on the 'empty' model) • Unit ships assembled, including totes and rail sets; glides/casters are field installed	44 x 18 x 27-3/4\"	RKT441828OP/3T	<input type="checkbox"/> <input type="checkbox"/> <input type="checkbox"/>	<input type="checkbox"/> <input type="checkbox"/>	123.4#	\$ 1848
RCKT							
	Short 3-Column Unit, Open with (9) 6\" Totes • Single-Face only • Totes included are translucent with no lid (not included on the 'empty' model) • Unit ships assembled, including totes and rail sets; glides/casters are field installed	44 x 18 x 27-3/4\"	RKT441828OP/6T	<input type="checkbox"/> <input type="checkbox"/> <input type="checkbox"/>	<input type="checkbox"/> <input type="checkbox"/>	117.5#	\$ 1708
RCKT							
	Short 3-Column Unit, Open with (12) 3\" and (3) 6\" Totes • Single-Face only • Totes included are translucent with no lid (not included on the 'empty' model) • Unit ships assembled, including totes and rail sets; glides/casters are field installed	44 x 18 x 27-3/4\"	RKT441828OP/36T	<input type="checkbox"/> <input type="checkbox"/> <input type="checkbox"/>	<input type="checkbox"/> <input type="checkbox"/>	124.6#	\$ 1816
RCKT							
	Short 3-Column Unit, Open-Empty • Single-Face only • Tote and rail sets must be ordered separately and installed on-site • Unit ships assembled; glides/casters are field installed	44 x 18 x 27-3/4\"	RKT441828OP/XT	<input type="checkbox"/> <input type="checkbox"/> <input type="checkbox"/>	<input type="checkbox"/> <input type="checkbox"/>	102.7#	\$ 1410
RCKT							

A

B

C

HOW TO ORDER

- Indicate the following information on order form:
- Quantity of each item.
 - Model number, including options. See "How To Build a Model Number".
 - Any special service required.

Note:

- The indicates that a choice is required.
- The absence of the indicates that no choice is required.
- Alpha-numeric characters in place of indicate that no other alternatives are available.

HOW TO BUILD A MODEL NUMBER

- A** Select basic model.
- B** Select base option.

4CW	- 4 black casters
4GB	- 4 black glides
- C** Select shell color. Refer to the **Product Color Options** page in this price list.

SPECIAL SERVICES

Special Carton Marking

With specially marked information N/C

Shipping
Ships **assembled, FOB Pembroke, ON K8A 0E1, freight prepaid.** Freight class 100.

Specifications and prices are subject to change without prior notice.

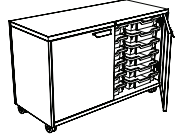
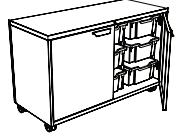
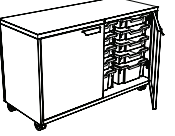
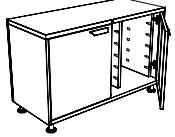

MODEL	W x D x H	MODEL NUMBER							Approx. Packaged Weight	Delivered Pricing	
		Basic Model	Pull Option	Base	Shell Color	Door Color	Lock Option	Lock Color			
 <p>RCKT</p> <p>Short 3-Column Unit with Doors and (18)3" Totes</p> <ul style="list-style-type: none"> • Single-Face only • Totes included are translucent with no lid (not included on the 'empty' model) • Unit ships assembled, including totes and rail sets; glides/casters are field installed • Secure locking doors 	44 x 18 x 27-3/4"	RKT441828DR/3T	<input type="checkbox"/>	<input type="checkbox"/>	<input type="checkbox"/>	<input type="checkbox"/>	<input type="checkbox"/>	<input type="checkbox"/>	149.40#	\$ 2137	
 <p>RCKT</p> <p>Short 3-Column Unit with Doors and (9)6" Totes</p> <ul style="list-style-type: none"> • Single-Face only • Totes included are translucent with no lid (not included on the 'empty' model) • Unit ships assembled, including totes and rail sets; glides/casters are field installed • Secure locking doors 	44 x 18 x 27-3/4"	RKT441828DR/6T	<input type="checkbox"/>	<input type="checkbox"/>	<input type="checkbox"/>	<input type="checkbox"/>	<input type="checkbox"/>	<input type="checkbox"/>	143.50#	\$ 1997	
 <p>RCKT</p> <p>Short 3-Column Unit with Doors and (12)3" and (3)6" Totes</p> <ul style="list-style-type: none"> • Single-Face only • Totes included are translucent with no lid (not included on the 'empty' model) • Unit ships assembled, including totes and rail sets; glides/casters are field installed • Secure locking doors 	44 x 18 x 27-3/4"	RKT441828DR/36T	<input type="checkbox"/>	<input type="checkbox"/>	<input type="checkbox"/>	<input type="checkbox"/>	<input type="checkbox"/>	<input type="checkbox"/>	150.60#	\$ 2105	
 <p>RCKT</p> <p>Short 3-Column Unit with Doors-Empty</p> <ul style="list-style-type: none"> • Single-Face only • Tote and rail sets must be ordered separately and installed on-site • Unit ships assembled; glides/casters are field installed • Secure locking doors 	44 x 18 x 27-3/4"	RKT441828DR/XT	<input type="checkbox"/>	<input type="checkbox"/>	<input type="checkbox"/>	<input type="checkbox"/>	<input type="checkbox"/>	<input type="checkbox"/>	128.70#	\$ 1699	
			A	B	C	D	E	F	G		

HOW TO ORDER

- Indicate the following information on order form:
1. Quantity of each item.
 2. Model number, including options. See "How To Build a Model Number".
 3. Any special service required.

Note:

- The indicates that a choice is required.
- The absence of the indicates that no choice is required.
- Alpha-numeric characters in place of indicate that no other alternatives are available.

HOW TO BUILD A MODEL NUMBER

Refer to the **Product Color Options** page in this price list.

- A** Select basic model.
- B** Select pull option.
 - S6** - Beveled pull Black
 - S5** - Beveled pull Satin Chrome
- C** Select base option.
 - 4CW** - 4 black casters
 - 4GB** - 4 black glides
- D** Select shell color. Refer to the **Product Color Options** page in this price list.
- E** Select front door color. Refer to the **Product Color Options** page in this price list.
- F** Select lock option.
 - KS** - Key standard - 2 locks
 - NLC** - No lock core - 2 locks
- G** Select lock color.

SPECIAL SERVICES

Special Carton Marking

With specially marked information N/C

Shipping

Ships assembled, FOB Pembroke, ON K8A 0E1, freight prepaid. Freight class 100.

Specifications and prices are subject to change without prior notice.

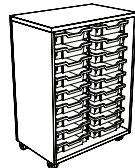
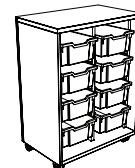
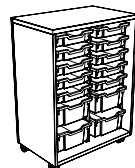
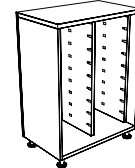

MODEL	W x D x H	MODEL NUMBER			Approx. Packaged Weight	Delivered Pricing
		Basic Model	Base	Shell Color		
 <p>Tall 2-Column Unit, Open with (18)3” Totes</p> <ul style="list-style-type: none"> • Single-Face only • Totes included are translucent with no lid (not included on the 'empty' model) • Unit ships assembled, including totes and rail sets; glides/casters are field installed 	30 x 18 x 40-3/4”	RKT301841OP/3T	<input type="checkbox"/> <input type="checkbox"/> <input type="checkbox"/>	<input type="checkbox"/> <input type="checkbox"/>	111.8#	\$ 1781
RCKT						
 <p>Tall 2-Column Unit, Open with (8)6” Totes</p> <ul style="list-style-type: none"> • Single-Face only • Totes included are translucent with no lid (not included on the 'empty' model) • Unit ships assembled, including totes and rail sets; glides/casters are field installed 	30 x 18 x 40-3/4”	RKT301841OP/6T	<input type="checkbox"/> <input type="checkbox"/> <input type="checkbox"/>	<input type="checkbox"/> <input type="checkbox"/>	104.3#	\$ 1607
RCKT						
 <p>Tall 2-Column Unit, Open with (10)3” and (4)6” Totes</p> <ul style="list-style-type: none"> • Single-Face only • Totes included are translucent with no lid (not included on the 'empty' model) • Unit ships assembled, including totes and rail sets; glides/casters are field installed 	30 x 18 x 40-3/4”	RKT301841OP/36T	<input type="checkbox"/> <input type="checkbox"/> <input type="checkbox"/>	<input type="checkbox"/> <input type="checkbox"/>	109.2#	\$ 1727
RCKT						
 <p>Tall 2-Column Unit, Open-Empty</p> <ul style="list-style-type: none"> • Single-Face only • Tote and rail sets must be ordered separately and installed on-site • Unit ships assembled; glides/casters are field installed 	30 x 18 x 40-3/4”	RKT301841OP/XT	<input type="checkbox"/> <input type="checkbox"/> <input type="checkbox"/>	<input type="checkbox"/> <input type="checkbox"/>	91.1#	\$ 1341
RCKT						

A **B** **C**

HOW TO ORDER

- Indicate the following information on order form:
1. Quantity of each item.
 2. Model number, including options. See “How To Build a Model Number”.
 3. Any special service required.

Note:

- The indicates that a choice is required.
- The absence of the indicates that no choice is required.
- Alpha-numeric characters in place of indicate that no other alternatives are available.

HOW TO BUILD A MODEL NUMBER

- A** Select basic model.
- B** Select base option.

4CW	- 4 black casters
4GB	- 4 black glides
- C** Select shell color. Refer to the **Product Color Options** page in this price list.

SPECIAL SERVICES

Special Carton Marking



With specially marked information N/C

Shipping

Ships assembled, FOB Pembroke, ON K8A 0E1, freight prepaid. Freight class 100.

Specifications and prices are subject to change without prior notice.

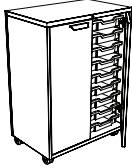

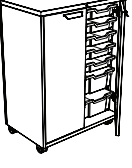
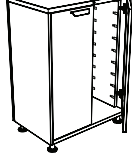
MODEL	W x D x H	MODEL NUMBER							Approx. Packaged Weight	Delivered Pricing
		Basic Model	Pull Option	Base	Shell Color	Door Color	Lock Option	Lock Color		
 <p>Tall 2-Column Unit with Doors and (18)3 Totes • Single-Face only • Totes included are translucent with no lid (not included on the 'empty' model) • Unit ships assembled, including totes and rail sets; glides/casters are field installed • Secure locking doors</p>	30 x 18 x 40-3/4"	RKT301841DR/3T	<input type="checkbox"/>	<input type="checkbox"/>	<input type="checkbox"/>	<input type="checkbox"/>	<input type="checkbox"/>	<input type="checkbox"/>	137.8#	\$ 2075
 <p>Tall 2-Column Unit with Doors and (8)6 Totes • Single-Face only • Totes included are translucent with no lid (not included on the 'empty' model) • Unit ships assembled, including totes and rail sets; glides/casters are field installed • Secure locking doors</p>	30 x 18 x 40-3/4"	RKT301841DR/6T	<input type="checkbox"/>	<input type="checkbox"/>	<input type="checkbox"/>	<input type="checkbox"/>	<input type="checkbox"/>	<input type="checkbox"/>	130.3#	\$ 1899
 <p>Tall 2-Column Unit with Doors and (10)3 and (4)6 Totes • Single-Face only • Totes included are translucent with no lid (not included on the 'empty' model) • Unit ships assembled, including totes and rail sets; glides/casters are field installed • Secure locking doors</p>	30 x 18 x 40-3/4"	RKT301841DR/36T	<input type="checkbox"/>	<input type="checkbox"/>	<input type="checkbox"/>	<input type="checkbox"/>	<input type="checkbox"/>	<input type="checkbox"/>	135.2#	\$ 2021
 <p>Tall 2-Column Unit with Doors-Empty • Single-Face only • Tote and rail sets must be ordered separately and installed on-site • Unit ships assembled; glides/casters are field installed • Secure locking doors</p>	30 x 18 x 40-3/4"	RKT301841DR/XT	<input type="checkbox"/>	<input type="checkbox"/>	<input type="checkbox"/>	<input type="checkbox"/>	<input type="checkbox"/>	<input type="checkbox"/>	117.1#	\$ 1637

A **B** **C** **D** **E** **F** **G**

HOW TO ORDER

- Indicate the following information on order form:
- Quantity of each item.
 - Model number, including options. See "How To Build a Model Number".
 - Any special service required.

Note: • The indicates that a choice is required.
 • The absence of the indicates that no choice is required.
 • Alpha-numeric characters in place of indicate that no other alternatives are available.

HOW TO BUILD A MODEL NUMBER

Refer to the **Product Color Options** page in this price list.

- A** Select basic model.
- B** Select pull option.
S6 - Beveled pull Black
S5 - Beveled pull Satin Chrome
- C** Select base option.
4CW - 4 black casters
4GB - 4 black glides
- D** Select shell color.
 Refer to the **Product Color Options** page in this price list.
- E** Select front door color.
 Refer to the **Product Color Options** page in this price list.
- F** Select lock option.
KS - Key standard - 2 locks
NLC - No lock core - 2 locks
- G** Select lock color.

SPECIAL SERVICES

Special Carton Marking

With specially marked information N/C

Shipping

Ships **assembled, FOB Pembroke, ON K8A 0E1, freight prepaid.** Freight class 100.

Specifications and prices are subject to change without prior notice.

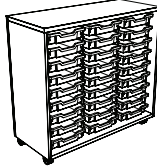
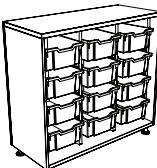
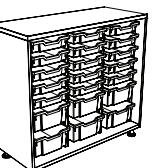
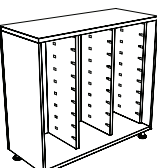

MODEL	W x D x H	MODEL NUMBER			Approx. Packaged Weight	Delivered Pricing
		Basic Model	Base	Shell Color		
 <p>Tall 3-Column Unit, Open with (27)3” Totes</p> <ul style="list-style-type: none"> • Single-Face only • Totes included are translucent with no lid (not included on the 'empty' model) • Unit ships assembled, including totes and rail sets; glides/casters are field installed 	44 x 18 x 40-3/4”	RKT441841OP/3T	<input type="checkbox"/> <input type="checkbox"/> <input type="checkbox"/>	<input type="checkbox"/>	156.7#	\$ 2266
RCKT						
 <p>Tall 3-Column Unit, Open with (12)6” Totes</p> <ul style="list-style-type: none"> • Single-Face only • Totes included are translucent with no lid (not included on the 'empty' model) • Unit ships assembled, including totes and rail sets; glides/casters are field installed 	44 x 18 x 40-3/4”	RKT441841OP/6T	<input type="checkbox"/> <input type="checkbox"/> <input type="checkbox"/>	<input type="checkbox"/>	145.4#	\$ 2035
RCKT						
 <p>Tall 3-Column Unit, Open with (15)3” and (6)6” Totes</p> <ul style="list-style-type: none"> • Single-Face only • Totes included are translucent with no lid (not included on the 'empty' model) • Unit ships assembled, including totes and rail sets; glides/casters are field installed 	44 x 18 x 40-3/4”	RKT441841OP/36T	<input type="checkbox"/> <input type="checkbox"/> <input type="checkbox"/>	<input type="checkbox"/>	147.0#	\$ 2210
RCKT						
 <p>Tall 3-Column Unit, Open-Empty</p> <ul style="list-style-type: none"> • Single-Face only • Tote and rail sets must be ordered separately and installed on-site • Unit ships assembled; glides/casters are field installed 	44 x 18 x 40-3/4”	RKT441841OP/XT	<input type="checkbox"/> <input type="checkbox"/> <input type="checkbox"/>	<input type="checkbox"/>	125.6#	\$ 1623
RCKT						

A **B** **C**

HOW TO ORDER

- Indicate the following information on order form:
1. Quantity of each item.
 2. Model number, including options. See “How To Build a Model Number”.
 3. Any special service required.

Note:

- The indicates that a choice is required.
- The absence of the indicates that no choice is required.
- Alpha-numeric characters in place of indicate that no other alternatives are available.

HOW TO BUILD A MODEL NUMBER

- A** Select basic model.
- B** Select base option.
 - 4CW** - 4 black casters
 - 4GB** - 4 black glides
- C** Select shell color. Refer to the **Product Color Options** page in this price list.

SPECIAL SERVICES

Special Carton Marking

With specially marked information N/C

Shipping

Ships assembled, FOB Pembroke, ON K8A 0E1, freight prepaid. Freight class 100.

Specifications and prices are subject to change without prior notice.

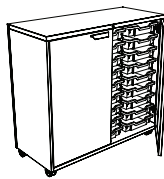
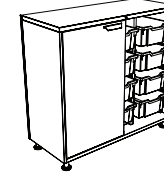
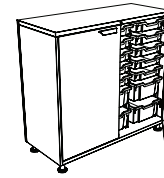
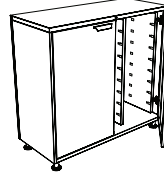

MODEL	W x D x H	MODEL NUMBER							Approx. Packaged Weight	Delivered Pricing
		Basic Model	Pull Option	Base	Shell Color	Door Color	Lock Option	Lock Color		
 <p>Tall 3-Column Unit with Doors and (27)3" Totes • Single-Face only • Totes included are translucent with no lid (not included on the 'empty' model) • Unit ships assembled, including totes and rail sets; glides/casters are field installed • Secure locking doors</p>	44 x 18 x 40-3/4"	RKT441841DR/3T	<input type="checkbox"/>	<input type="checkbox"/>	<input type="checkbox"/>	<input type="checkbox"/>	<input type="checkbox"/>	<input type="checkbox"/>	182.7#	\$ 2529
 <p>Tall 3-Column Unit with Doors and (12)6" Totes • Single-Face only • Totes included are translucent with no lid (not included on the 'empty' model) • Unit ships assembled, including totes and rail sets; glides/casters are field installed • Secure locking doors</p>	44 x 18 x 40-3/4"	RKT441841DR/6T	<input type="checkbox"/>	<input type="checkbox"/>	<input type="checkbox"/>	<input type="checkbox"/>	<input type="checkbox"/>	<input type="checkbox"/>	171.4#	\$ 2299
 <p>Tall 3-Column Unit with Doors and (15)3" and (6)6" Totes • Single-Face only • Totes included are translucent with no lid (not included on the 'empty' model) • Unit ships assembled, including totes and rail sets; glides/casters are field installed • Secure locking doors</p>	44 x 18 x 40-3/4"	RKT441841DR/36T	<input type="checkbox"/>	<input type="checkbox"/>	<input type="checkbox"/>	<input type="checkbox"/>	<input type="checkbox"/>	<input type="checkbox"/>	173.0#	\$ 2476
 <p>Tall 3-Column Unit with Doors-Empty • Single-Face only • Tote and rail sets must be ordered separately and installed on-site • Unit ships assembled; glides/casters are field installed • Secure locking doors</p>	44 x 18 x 40-3/4"	RKT441841DR/XT	<input type="checkbox"/>	<input type="checkbox"/>	<input type="checkbox"/>	<input type="checkbox"/>	<input type="checkbox"/>	<input type="checkbox"/>	151.6#	\$ 1888

A **B** **C** **D** **E** **F** **G**

HOW TO ORDER

- Indicate the following information on order form:
- Quantity of each item.
 - Model number, including options. See "How To Build a Model Number".
 - Any special service required.

Note: • The indicates that a choice is required.
 • The absence of the indicates that no choice is required.
 • Alpha-numeric characters in place of indicate that no other alternatives are available.

HOW TO BUILD A MODEL NUMBER

Refer to the **Product Color Options** page in this price list.

- A** Select basic model.
- B** Select pull option.
S6 - Beveled pull Black
S5 - Beveled pull Satin Chrome
- C** Select base option.
4CW - 4 black casters
4GB - 4 black glides
- D** Select shell color.
 Refer to the **Product Color Options** page in this price list.
- E** Select front door color.
 Refer to the **Product Color Options** page in this price list.
- F** Select lock option.
KS - Key standard - 2 locks
NLC - No lock core - 2 locks
- G** Select lock color.

SPECIAL SERVICES

Special Carton Marking

With specially marked information N/C

Shipping

Ships assembled, FOB Pembroke, ON K8A 0E1, freight prepaid. Freight class 100.

Specifications and prices are subject to change without prior notice.



Ruckus® Storage (Delivered Pricing)

Totes with Laminate Top



Ruckus® Storage (Delivered Pricing)

Totes with Laminate Top

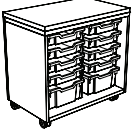
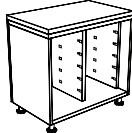
MODEL	W x D x H	MODEL NUMBER					Approx. Packaged Weight	Delivered Pricing	Laminate Grade 2 add to list price
		Basic Model	Base	Top Color	Edge Color	Shell Color			
 <p>RCKT</p> <p>Short 2-Column Unit, Open with Laminate top and (12)3" Totes</p> <ul style="list-style-type: none"> Laminate top (1-1/4" with 74P edge) Single-Face only Totes included are translucent with no lid (not included on the 'empty' model) Unit ships assembled, including totes and rail sets; glides/casters are field installed 	30 x 18 x 29"	RKT301829OPT/3T	<input type="checkbox"/>	<input type="checkbox"/>	<input type="checkbox"/>	<input type="checkbox"/>	107.2#	\$ 1721	\$ 19
 <p>RCKT</p> <p>Short 2-Column Unit, Open with Laminate top and (6)6" Totes</p> <ul style="list-style-type: none"> Laminate top (1-1/4" with 74P edge) Single-Face only Totes included are translucent with no lid (not included on the 'empty' model) Unit ships assembled, including totes and rail sets; glides/casters are field installed 	30 x 18 x 29"	RKT301829OPT/6T	<input type="checkbox"/>	<input type="checkbox"/>	<input type="checkbox"/>	<input type="checkbox"/>	103.4#	\$ 1617	\$ 19
 <p>RCKT</p> <p>Short 2-Column Unit, Open with Laminate top and (8)3" and (2)6" Totes</p> <ul style="list-style-type: none"> Laminate top (1-1/4" with 74P edge) Single-Face only Totes included are translucent with no lid (not included on the 'empty' model) Unit ships assembled, including totes and rail sets; glides/casters are field installed 	30 x 18 x 29"	RKT301829OPT/36T	<input type="checkbox"/>	<input type="checkbox"/>	<input type="checkbox"/>	<input type="checkbox"/>	105.9#	\$ 1700	\$ 19
 <p>RCKT</p> <p>Short 2-Column Unit, Open with Laminate top-Empty</p> <ul style="list-style-type: none"> Laminate top (1-1/4" with 74P edge) Single-Face only Tote and rail sets must be ordered separately and installed on-site Unit ships assembled; glides/casters are field installed 	30 x 18 x 29"	RKT301829OPT/XT	<input type="checkbox"/>	<input type="checkbox"/>	<input type="checkbox"/>	<input type="checkbox"/>	93.4#	\$ 1419	\$ 19

A **B** **C** **D** **E**

HOW TO ORDER

- Indicate the following information on order form:
- Quantity of each item.
 - Model number, including options. See "How To Build a Model Number".
 - Any special service required.

Note:

- The indicates that a choice is required.
- The absence of the indicates that no choice is required.
- Alpha-numeric characters in place of indicate that no other alternatives are available.

HOW TO BUILD A MODEL NUMBER

- A** Select basic model.
- B** Select base option.

4CW	- 4 black casters
4GB	- 4 black glides
- C** Select top laminate surface. Refer to the **Product Color Options** page in this price list.
- D** Select edge color. Refer to the **Product Color Options** page in this price list.
- E** Select shell color. Refer to the **Product Color Options** page in this price list.

FINISH INFORMATION

Additional Laminate Offering

KI offers laminates beyond those offered in the standard offering. Laminates that are currently available in the program can be viewed in KI product specification tools. Requests to add laminates to the program can be submitted via the product modification request process. Please note, requests to add laminates to the program must include the laminate manufacturer's name, color/pattern number, and finish code. Edge options are limited to standard edge colors. If a matching edge is required, this will need to be requested through the product modification request process and may be subject to additional costs. Due to varying manufacturing processes and quality issues with some laminates, some requests may be denied. Extended lead times and minimum order quantities may apply on orders containing special laminates. Contact the product modification team for questions or additional information regarding special laminates and pricing.

SPECIAL SERVICES

Special Carton Marking

With specially marked information N/C

Shipping
Ships **assembled, FOB Pembroke, ON K8A 0E1, freight prepaid.** Freight class 100.

Specifications and prices are subject to change without prior notice.

Ruckus® Storage (Delivered Pricing)

Totes with Laminate Top



Ruckus® Storage (Delivered Pricing)

Totes with Laminate Top

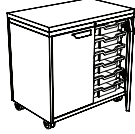
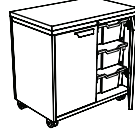
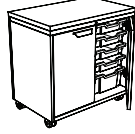
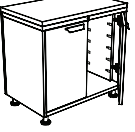
MODEL	W x D x H	MODEL NUMBER									Approx. Packaged Weight	Delivered Pricing	Laminate Grade 2 add to list price
		Basic Model	Pull Option	Base	Top Color	Edge Color	Shell Color	Door Color	Lock Option	Lock Color			
 <p>Short 2-Column Unit with Doors, Laminate Top and (12)3” Totes</p> <ul style="list-style-type: none"> Laminate top (1-1/4” with 74P edge) Single-Face only Totes included are translucent with no lid (not included on the 'empty' model) Unit ships assembled, including totes and rail sets; glides/casters are field installed Secure locking doors 	30 x 18 x 29”	RKT301829DRT/3T	<input type="checkbox"/>	<input type="checkbox"/>	<input type="checkbox"/>	<input type="checkbox"/>	<input type="checkbox"/>	<input type="checkbox"/>	<input type="checkbox"/>	<input type="checkbox"/>	131.5#	\$ 1969	\$ 19
 <p>Short 2-Column Unit with Doors, Laminate Top and (6)6” Totes</p> <ul style="list-style-type: none"> Laminate top (1-1/4” with 74P edge) Single-Face only Totes included are translucent with no lid (not included on the 'empty' model) Unit ships assembled, including totes and rail sets; glides/casters are field installed Secure locking doors 	30 x 18 x 29”	RKT301829DRT/6T	<input type="checkbox"/>	<input type="checkbox"/>	<input type="checkbox"/>	<input type="checkbox"/>	<input type="checkbox"/>	<input type="checkbox"/>	<input type="checkbox"/>	<input type="checkbox"/>	127.7#	\$ 1867	\$ 19
 <p>Short 2-Column Unit with Doors, Laminate Top and (8)3” and (2)6” Totes</p> <ul style="list-style-type: none"> Laminate top (1-1/4” with 74P edge) Single-Face only Totes included are translucent with no lid (not included on the 'empty' model) Unit ships assembled, including totes and rail sets; glides/casters are field installed Secure locking doors 	30 x 18 x 29”	RKT301829DRT/36T	<input type="checkbox"/>	<input type="checkbox"/>	<input type="checkbox"/>	<input type="checkbox"/>	<input type="checkbox"/>	<input type="checkbox"/>	<input type="checkbox"/>	<input type="checkbox"/>	130.2#	\$ 1948	\$ 19
 <p>Short 2-Column Unit with Doors and Laminate Top-Empty</p> <ul style="list-style-type: none"> Laminate top (1-1/4” with 74P edge) Single-Face only Tote and rail sets must be ordered separately and installed on-site Unit ships assembled; glides/casters are field installed Secure locking doors 	30 x 18 x 29”	RKT301829DRT/XT	<input type="checkbox"/>	<input type="checkbox"/>	<input type="checkbox"/>	<input type="checkbox"/>	<input type="checkbox"/>	<input type="checkbox"/>	<input type="checkbox"/>	<input type="checkbox"/>	117.7#	\$ 1668	\$ 19

A **B** **C** **D** **E** **F** **G** **H** **I**

HOW TO ORDER

- Indicate the following information on order form:
- Quantity of each item.
 - Model number, including options. See "How To Build a Model Number".
 - Any special service required.

Note: • The indicates that a choice is required.
 • The absence of the indicates that no choice is required.
 • Alpha-numeric characters in place of indicate that no other alternatives are available.

HOW TO BUILD A MODEL NUMBER

- A** Select basic model.
- B** Select pull option.

S6	- Beveled pull Black
S5	- Beveled pull Satin Chrome
- C** Select base option.

4CW	- 4 black casters
4GB	- 4 black glides
- D** Select top laminate surface.
Refer to the **Product Color Options** page in this price list.
- E** Select edge color.
Refer to the **Product Color Options** page in this price list.
- F** Select shell color.
Refer to the **Product Color Options** page in this price list.
- G** Select front door color.

Refer to the **Product Color Options** page in this price list.

- H** Select lock option.

KS	- Key standard - 2 locks
NLC	- No lock core - 2 locks

I Select lock color.
Refer to the **Product Color Options** page in this price list.

FINISH INFORMATION

Additional Laminate Offering

KI offers laminates beyond those offered in the standard offering. Laminates that are currently available in the program can be viewed in KI product specification tools. Requests to add laminates to the program can be submitted via the product modification request process. Please note, requests to add laminates to the program must include the laminate manufacturer's name, color/pattern number, and finish code. Edge options are limited to standard edge colors. If a matching edge is required, this will need to be requested through the product modification request process and may be subject to additional costs. Due to varying manufacturing processes and quality issues with some laminates, some requests may be denied. Extended lead times and minimum order quantities may apply on orders containing special laminates. Contact the product modification team for questions or additional information regarding special laminates and pricing.

SPECIAL SERVICES

Special Carton Marking

With specially marked information N/C

Shipping
Ships assembled, FOB Pembroke, ON K8A 0E1, freight prepaid. Freight class 100.

Specifications and prices are subject to change without prior notice.

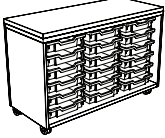
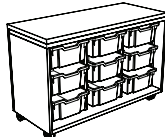
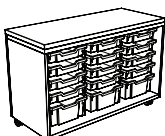
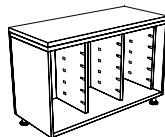

MODEL	W x D x H	MODEL NUMBER					Approx. Packaged Weight	Delivered Pricing	Laminate Grade 2 add to list price
		Basic Model	Base	Top Color	Edge Color	Shell Color			
 <p>RCKT</p> <p>Short 3-Column Unit, Open with Laminate top and (18)3" Totes</p> <ul style="list-style-type: none"> Laminate top (1-1/4" with 74P edge) Single-Face only Totes included are translucent with no lid (not included on the 'empty' model) Unit ships assembled, including totes and rail sets; glides/casters are field installed 	44 x 18 x 29"	RKT441829OPT/3T	<input type="checkbox"/>	<input type="checkbox"/>	<input type="checkbox"/>	<input type="checkbox"/>	151.1#	\$ 2159	\$ 19
 <p>RCKT</p> <p>Short 3-Column Unit, Open with Laminate top and (9)6" Totes</p> <ul style="list-style-type: none"> Laminate top (1-1/4" with 74P edge) Single-Face only Totes included are translucent with no lid (not included on the 'empty' model) Unit ships assembled, including totes and rail sets; glides/casters are field installed 	44 x 18 x 29"	RKT441829OPT/6T	<input type="checkbox"/>	<input type="checkbox"/>	<input type="checkbox"/>	<input type="checkbox"/>	145.9#	\$ 2017	\$ 19
 <p>RCKT</p> <p>Short 3-Column Unit, Open with Laminate top and (12)3" and (3)6" Totes</p> <ul style="list-style-type: none"> Laminate top (1-1/4" with 74P edge) Single-Face only Totes included are translucent with no lid (not included on the 'empty' model) Unit ships assembled, including totes and rail sets; glides/casters are field installed 	44 x 18 x 29"	RKT441829OPT/36T	<input type="checkbox"/>	<input type="checkbox"/>	<input type="checkbox"/>	<input type="checkbox"/>	153.0#	\$ 2123	\$ 19
 <p>RCKT</p> <p>Short 3-Column Unit, Open with Laminate top-Empty</p> <ul style="list-style-type: none"> Laminate top (1-1/4" with 74P edge) Single-Face only Tote and rail sets must be ordered separately and installed on-site Unit ships assembled; glides/casters are field installed 	44 x 18 x 29"	RKT441829OPT/XT	<input type="checkbox"/>	<input type="checkbox"/>	<input type="checkbox"/>	<input type="checkbox"/>	131.1#	\$ 1719	\$ 19

A **B** **C** **D** **E**

HOW TO ORDER

- Indicate the following information on order form:
- Quantity of each item.
 - Model number, including options. See "How To Build a Model Number".
 - Any special service required.

Note:

- The indicates that a choice is required.
- The absence of the indicates that no choice is required.
- Alpha-numeric characters in place of indicate that no other alternatives are available.

HOW TO BUILD A MODEL NUMBER

- A** Select basic model.
- B** Select base option.

4CW	- 4 black casters
4GB	- 4 black glides
- C** Select top laminate surface. Refer to the **Product Color Options** page in this price list.
- D** Select edge color. Refer to the **Product Color Options** page in this price list.
- E** Select shell color. Refer to the **Product Color Options** page in this price list.

FINISH INFORMATION

Additional Laminate Offering

KI offers laminates beyond those offered in the standard offering. Laminates that are currently available in the program can be viewed in KI product specification tools. Requests to add laminates to the program can be submitted via the product modification request process. Please note, requests to add laminates to the program must include the laminate manufacturer's name, color/pattern number, and finish code. Edge options are limited to standard edge colors. If a matching edge is required, this will need to be requested through the product modification request process and may be subject to additional costs. Due to varying manufacturing processes and quality issues with some laminates, some requests may be denied. Extended lead times and minimum order quantities may apply on orders containing special laminates. Contact the product modification team for questions or additional information regarding special laminates and pricing.

SPECIAL SERVICES

Special Carton Marking

With specially marked information N/C

Shipping
Ships **assembled, FOB Pembroke, ON K8A 0E1, freight prepaid.** Freight class 100.

Specifications and prices are subject to change without prior notice.

Ruckus® Storage (Delivered Pricing)

Totes with Laminate Top



Ruckus® Storage (Delivered Pricing)

Totes with Laminate Top

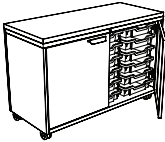
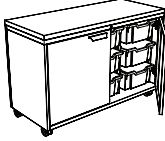
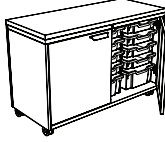
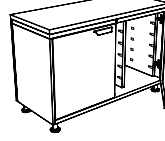
MODEL	W x D x H	MODEL NUMBER									Approx. Packaged Weight	Delivered Pricing	Laminate Grade 2 add to list price
		Basic Model	Pull Option	Base	Top Color	Edge Color	Shell Color	Door Color	Lock Option	Lock Color			
 RCKT Short 3-Column Unit with Doors, Laminate Top and (18)3" Totes • Laminate top (1-1/4" with 74P edge) • Single-Face only • Totes included are translucent with no lid (not included on the 'empty' model) • Unit ships assembled, including totes and rail sets; glides/casters are field installed • Secure locking doors	44 x 18 x 29"	RKT441829DRT/3T	<input type="checkbox"/>	<input type="checkbox"/>	<input type="checkbox"/>	<input type="checkbox"/>	<input type="checkbox"/>	<input type="checkbox"/>	<input type="checkbox"/>	<input type="checkbox"/>	177.8#	\$ 2436	\$ 19
 RCKT Short 3-Column Unit with Doors, Laminate Top and (9)6" Totes • Laminate top (1-1/4" with 74P edge) • Single-Face only • Totes included are translucent with no lid (not included on the 'empty' model) • Unit ships assembled, including totes and rail sets; glides/casters are field installed • Secure locking doors	44 x 18 x 29"	RKT441829DRT/6T	<input type="checkbox"/>	<input type="checkbox"/>	<input type="checkbox"/>	<input type="checkbox"/>	<input type="checkbox"/>	<input type="checkbox"/>	<input type="checkbox"/>	<input type="checkbox"/>	171.9#	\$ 2295	\$ 19
 RCKT Short 3-Column Unit with Doors, Laminate Top and (12)3" and (3)6" Totes • Laminate top (1-1/4" with 74P edge) • Single-Face only • Totes included are translucent with no lid (not included on the 'empty' model) • Unit ships assembled, including totes and rail sets; glides/casters are field installed • Secure locking doors	44 x 18 x 29"	RKT441829DRT/36T	<input type="checkbox"/>	<input type="checkbox"/>	<input type="checkbox"/>	<input type="checkbox"/>	<input type="checkbox"/>	<input type="checkbox"/>	<input type="checkbox"/>	<input type="checkbox"/>	179.0#	\$ 2401	\$ 19
 RCKT Short 3-Column Unit with Doors and Laminate Top-Empty • Laminate top (1-1/4" with 74P edge) • Single-Face only • Tote and rail sets must be ordered separately and installed on-site • Unit ships assembled; glides/casters are field installed • Secure locking doors	44 x 18 x 29"	RKT441829DRT/XT	<input type="checkbox"/>	<input type="checkbox"/>	<input type="checkbox"/>	<input type="checkbox"/>	<input type="checkbox"/>	<input type="checkbox"/>	<input type="checkbox"/>	<input type="checkbox"/>	157.1#	\$ 1997	\$ 19

A **B** **C** **D** **E** **F** **G** **H** **I**

HOW TO ORDER

- Indicate the following information on order form:
- Quantity of each item.
 - Model number, including options. See "How To Build a Model Number".
 - Any special service required.

Note: • The indicates that a choice is required.
 • The absence of the indicates that no choice is required.
 • Alpha-numeric characters in place of indicate that no other alternatives are available.

HOW TO BUILD A MODEL NUMBER

- A** Select basic model.
- B** Select pull option.
S6 - Beveled pull Black
S5 - Beveled pull Satin Chrome
- C** Select base option.
4CW - 4 black casters
4GB - 4 black glides
- D** Select top laminate surface.
 Refer to the **Product Color Options** page in this price list.
- E** Select edge color.
 Refer to the **Product Color Options** page in this price list.
- F** Select shell color.
 Refer to the **Product Color Options** page in this price list.
- G** Select front door color.

Refer to the **Product Color Options** page in this price list.

- H** Select lock option.
KS - Key standard - 2 locks
NLC - No lock core - 2 locks

I Select lock color.
 Refer to the **Product Color Options** page in this price list.

FINISH INFORMATION

Additional Laminate Offering

KI offers laminates beyond those offered in the standard offering. Laminates that are currently available in the program can be viewed in KI product specification tools. Requests to add laminates to the program can be submitted via the product modification request process. Please note, requests to add laminates to the program must include the laminate manufacturer's name, color/pattern number, and finish code. Edge options are limited to standard edge colors. If a matching edge is required, this will need to be requested through the product modification request process and may be subject to additional costs. Due to varying manufacturing processes and quality issues with some laminates, some requests may be denied. Extended lead times and minimum order quantities may apply on orders containing special laminates. Contact the product modification team for questions or additional information regarding special laminates and pricing.

SPECIAL SERVICES

Special Carton Marking

With specially marked information N/C

Shipping

Ships assembled, FOB Pembroke, ON K8A 0E1, freight prepaid. Freight class 100.

Specifications and prices are subject to change without prior notice.

Ruckus® Storage (Delivered Pricing)

Totes with Laminate Top



Ruckus® Storage (Delivered Pricing)

Totes with Laminate Top

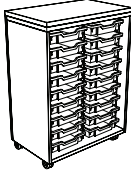
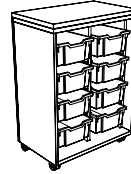
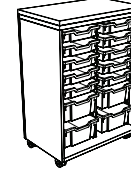
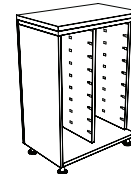
MODEL	W x D x H	MODEL NUMBER					Approx. Packaged Weight	Delivered Pricing	Laminate Grade 2 add to list price
		Basic Model	Base	Top Color	Edge Color	Shell Color			
 <p>Tall 2-Column Unit, Open with Laminate Top and (18)3" Totes</p> <ul style="list-style-type: none"> Laminate top (1-1/4" with 74P edge) Single-Face only Totes included are translucent with no lid (not included on the 'empty' model) Unit ships assembled, including totes and rail sets; glides/casters are field installed 	30 x 18 x 42"	RKT301842OPT/3T	<input type="checkbox"/>	<input type="checkbox"/>	<input type="checkbox"/>	<input type="checkbox"/>	131.2#	\$ 2030	\$ 19
RCKT									
 <p>Tall 2-Column Unit, Open with Laminate Top and (8)6" Totes</p> <ul style="list-style-type: none"> Laminate top (1-1/4" with 74P edge) Single-Face only Totes included are translucent with no lid (not included on the 'empty' model) Unit ships assembled, including totes and rail sets; glides/casters are field installed 	30 x 18 x 42"	RKT301842OPT/6T	<input type="checkbox"/>	<input type="checkbox"/>	<input type="checkbox"/>	<input type="checkbox"/>	123.7#	\$ 1856	\$ 19
RCKT									
 <p>Tall 2-Column Unit, Open with Laminate Top and (10)3" and (4)6" Totes</p> <ul style="list-style-type: none"> Laminate top (1-1/4" with 74P edge) Single-Face only Totes included are translucent with no lid (not included on the 'empty' model) Unit ships assembled, including totes and rail sets; glides/casters are field installed 	30 x 18 x 42"	RKT301842OPT/36T	<input type="checkbox"/>	<input type="checkbox"/>	<input type="checkbox"/>	<input type="checkbox"/>	128.6#	\$ 1977	\$ 19
RCKT									
 <p>Tall 2-Column Unit, Open with Laminate Top-Empty</p> <ul style="list-style-type: none"> Laminate top (1-1/4" with 74P edge) Single-Face only Tote and rail sets must be ordered separately and installed on-site Unit ships assembled; glides/casters are field installed 	30 x 18 x 42"	RKT301842OPT/XT	<input type="checkbox"/>	<input type="checkbox"/>	<input type="checkbox"/>	<input type="checkbox"/>	110.5#	\$ 1592	\$ 19
RCKT									

A **B** **C** **D** **E**

HOW TO ORDER

- Indicate the following information on order form:
- Quantity of each item.
 - Model number, including options. See "How To Build a Model Number".
 - Any special service required.

Note: • The indicates that a choice is required.
 • The absence of the indicates that no choice is required.
 • Alpha-numeric characters in place of indicate that no other alternatives are available.

HOW TO BUILD A MODEL NUMBER

- A** Select basic model.
- B** Select base option.

4CW	- 4 black casters
4GB	- 4 black glides
- C** Select top laminate surface. Refer to the **Product Color Options** page in this price list.
- D** Select edge color. Refer to the **Product Color Options** page in this price list.
- E** Select shell color. Refer to the **Product Color Options** page in this price list.

FINISH INFORMATION

Additional Laminate Offering
 KI offers laminates beyond those offered in the standard offering. Laminates that are currently available in the program can be viewed in KI product specification tools. Requests to add laminates to the program can be submitted via the product modification request process. Please note, requests to add laminates to the program must include the laminate manufacturer's name, color/pattern number, and finish code. Edge options are limited to standard edge colors. If a matching edge is required, this will need to be requested through the product modification request process and may be subject to additional costs. Due to varying manufacturing processes and quality issues with some laminates, some requests may be denied. Extended lead times and minimum order quantities may apply on orders containing special laminates. Contact the product modification team for questions or additional information regarding special laminates and pricing.

SPECIAL SERVICES

Special Carton Marking

With specially marked information N/C

Shipping
 Ships assembled, FOB Pembroke, ON K8A 0E1, freight prepaid. Freight class 100.

Specifications and prices are subject to change without prior notice.

Ruckus® Storage (Delivered Pricing)

Totes with Laminate Top



Ruckus® Storage (Delivered Pricing)

Totes with Laminate Top

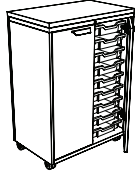
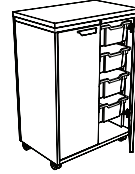
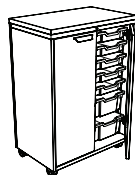
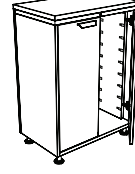
MODEL	W x D x H	MODEL NUMBER									Approx. Packaged Weight	Delivered Pricing	Laminate Grade 2 add to list price
		Basic Model	Pull Option	Base	Top Color	Edge Color	Shell Color	Door Color	Lock Option	Lock Color			
 <p>Tall 2-Column Unit with Laminate Top, Doors and (18)3" Totes</p> <ul style="list-style-type: none"> Laminate top (1-1/4" with 74P edge) Single-Face only Totes included are translucent with no lid (not included on the 'empty' model) Unit ships assembled, including totes and rail sets; glides/casters are field installed Secure locking doors 	30 x 18 x 42"	RKT301842DRT/3T	<input type="checkbox"/>	<input type="checkbox"/>	<input type="checkbox"/>	<input type="checkbox"/>	<input type="checkbox"/>	<input type="checkbox"/>	<input type="checkbox"/>	<input type="checkbox"/>	157.2#	\$ 2314	\$ 19
 <p>Tall 2-Column Unit with Laminate Top, Doors and (8)6" Totes</p> <ul style="list-style-type: none"> Laminate top (1-1/4" with 74P edge) Single-Face only Totes included are translucent with no lid (not included on the 'empty' model) Unit ships assembled, including totes and rail sets; glides/casters are field installed Secure locking doors 	30 x 18 x 42"	RKT301842DRT/6T	<input type="checkbox"/>	<input type="checkbox"/>	<input type="checkbox"/>	<input type="checkbox"/>	<input type="checkbox"/>	<input type="checkbox"/>	<input type="checkbox"/>	<input type="checkbox"/>	149.7#	\$ 2138	\$ 19
 <p>Tall 2-Column Unit with Laminate Top, Doors and (10)3" and (4)6" Totes</p> <ul style="list-style-type: none"> Laminate top (1-1/4" with 74P edge) Single-Face only Totes included are translucent with no lid (not included on the 'empty' model) Unit ships assembled, including totes and rail sets; glides/casters are field installed Secure locking doors 	30 x 18 x 42"	RKT301842DRT/36T	<input type="checkbox"/>	<input type="checkbox"/>	<input type="checkbox"/>	<input type="checkbox"/>	<input type="checkbox"/>	<input type="checkbox"/>	<input type="checkbox"/>	<input type="checkbox"/>	154.6#	\$ 2260	\$ 19
 <p>Tall 2-Column Unit with Laminate Top and Doors-Empty</p> <ul style="list-style-type: none"> Laminate top (1-1/4" with 74P edge) Single-Face only Tote and rail sets must be ordered separately and installed on-site Unit ships assembled; glides/casters are field installed Secure locking doors 	30 x 18 x 42"	RKT301842DRT/XT	<input type="checkbox"/>	<input type="checkbox"/>	<input type="checkbox"/>	<input type="checkbox"/>	<input type="checkbox"/>	<input type="checkbox"/>	<input type="checkbox"/>	<input type="checkbox"/>	136.5#	\$ 1875	\$ 19

A B C D E F G H I

HOW TO ORDER

- Indicate the following information on order form:
- Quantity of each item.
 - Model number, including options. See "How To Build a Model Number".
 - Any special service required.

Note: • The indicates that a choice is required.

- The absence of the indicates that no choice is required.
- Alpha-numeric characters in place of indicate that no other alternatives are available.

HOW TO BUILD A MODEL NUMBER

- A** Select basic model.
- B** Select pull option.
 - S6** - Beveled pull Black
 - S5** - Beveled pull Satin Chrome
- C** Select base option.
 - 4CW** - 4 black casters
 - 4GB** - 4 black glides
- D** Select top laminate surface. Refer to the **Product Color Options** page in this price list.
- E** Select edge color. Refer to the **Product Color Options** page in this price list.
- F** Select shell color. Refer to the **Product Color Options** page in this price list.
- G** Select front door color.

Refer to the **Product Color Options** page in this price list.

- H** Select lock option.
 - KS** - Key standard - 2 locks
 - NLC** - No lock core - 2 locks

I Select lock color. Refer to the **Product Color Options** page in this price list.

FINISH INFORMATION

Additional Laminate Offering

KI offers laminates beyond those offered in the standard offering. Laminates that are currently available in the program can be viewed in KI product specification tools. Requests to add laminates to the program can be submitted via the product modification request process. Please note, requests to add laminates to the program must include the laminate manufacturer's name, color/pattern number, and finish code. Edge options are limited to standard edge colors. If a matching edge is required, this will need to be requested through the product modification request process and may be subject to additional costs. Due to varying manufacturing processes and quality issues with some laminates, some requests may be denied. Extended lead times and minimum order quantities may apply on orders containing special laminates. Contact the product modification team for questions or additional information regarding special laminates and pricing.

SPECIAL SERVICES

Special Carton Marking

With specially marked information N/C

Shipping

Ships assembled, FOB Pembroke, ON K8A 0E1, freight prepaid. Freight class 100.

Specifications and prices are subject to change without prior notice.

Ruckus® Storage (Delivered Pricing)

Totes with Laminate Top



Ruckus® Storage (Delivered Pricing)

Totes with Laminate Top

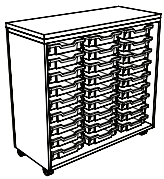
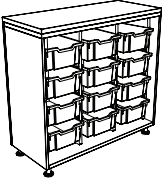
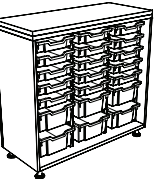
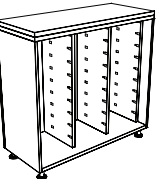
MODEL	W x D x H	MODEL NUMBER					Approx. Packaged Weight	Delivered Pricing	Laminate Grade 2 add to list price
		Basic Model	Base	Top Color	Edge Color	Shell Color			
 <p>Tall 3-Column Unit, Open with Laminate top and (27)3" Totes</p> <ul style="list-style-type: none"> Laminate top (1-1/4" with 74P edge) Single-Face only Totes included are translucent with no lid (not included on the 'empty' model) Unit ships assembled, including totes and rail sets; glides/casters are field installed 	44 x 18 x 42"	RKT441842OPT/3T	<input type="checkbox"/>	<input type="checkbox"/>	<input type="checkbox"/>	<input type="checkbox"/>	185.1#	\$ 2539	\$ 19
RCKT									
 <p>Tall 3-Column Unit, Open with Laminate top and (12)6" Totes</p> <ul style="list-style-type: none"> Laminate top (1-1/4" with 74P edge) Single-Face only Totes included are translucent with no lid (not included on the 'empty' model) Unit ships assembled, including totes and rail sets; glides/casters are field installed 	44 x 18 x 42"	RKT441842OPT/6T	<input type="checkbox"/>	<input type="checkbox"/>	<input type="checkbox"/>	<input type="checkbox"/>	173.8#	\$ 2287	\$ 19
RCKT									
 <p>Tall 3-Column Unit, Open with Laminate top and (15)3" and (6)6" Totes</p> <ul style="list-style-type: none"> Laminate top (1-1/4" with 74P edge) Single-Face only Totes included are translucent with no lid (not included on the 'empty' model) Unit ships assembled, including totes and rail sets; glides/casters are field installed 	44 x 18 x 42"	RKT441842OPT/36T	<input type="checkbox"/>	<input type="checkbox"/>	<input type="checkbox"/>	<input type="checkbox"/>	175.1#	\$ 2458	\$ 19
RCKT									
 <p>Tall 3-Column Unit, Open with Laminate top-Empty</p> <ul style="list-style-type: none"> Laminate top (1-1/4" with 74P edge) Single-Face only Tote and rail sets must be ordered separately and installed on-site Unit ships assembled; glides/casters are field installed 	44 x 18 x 42"	RKT441842OPT/XT	<input type="checkbox"/>	<input type="checkbox"/>	<input type="checkbox"/>	<input type="checkbox"/>	154.0#	\$ 1884	\$ 19
RCKT									

A **B** **C** **D** **E**

HOW TO ORDER

- Indicate the following information on order form:
- Quantity of each item.
 - Model number, including options. See "How To Build a Model Number".
 - Any special service required.

Note: • The indicates that a choice is required.
 • The absence of the indicates that no choice is required.
 • Alpha-numeric characters in place of indicate that no other alternatives are available.

HOW TO BUILD A MODEL NUMBER

- A** Select basic model.
- B** Select base option.

4CW	- 4 black casters
4GB	- 4 black glides
- C** Select top laminate surface. Refer to the **Product Color Options** page in this price list.
- D** Select edge color. Refer to the **Product Color Options** page in this price list.
- E** Select shell color. Refer to the **Product Color Options** page in this price list.

FINISH INFORMATION

Additional Laminate Offering
 KI offers laminates beyond those offered in the standard offering. Laminates that are currently available in the program can be viewed in KI product specification tools. Requests to add laminates to the program can be submitted via the product modification request process. Please note, requests to add laminates to the program must include the laminate manufacturer's name, color/pattern number, and finish code. Edge options are limited to standard edge colors. If a matching edge is required, this will need to be requested through the product modification request process and may be subject to additional costs. Due to varying manufacturing processes and quality issues with some laminates, some requests may be denied. Extended lead times and minimum order quantities may apply on orders containing special laminates. Contact the product modification team for questions or additional information regarding special laminates and pricing.

SPECIAL SERVICES

Special Carton Marking

With specially marked information N/C

Shipping
 Ships assembled, FOB Pembroke, ON K8A 0E1, freight prepaid. Freight class 100.

Specifications and prices are subject to change without prior notice.

Ruckus® Storage (Delivered Pricing)

Totes with Laminate Top



Ruckus® Storage (Delivered Pricing)

Totes with Laminate Top

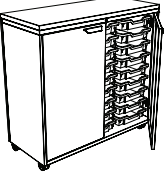
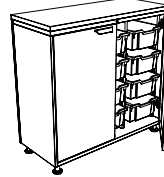
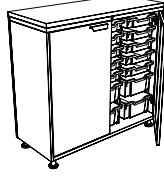
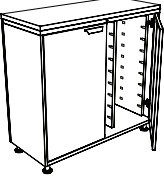
MODEL	W x D x H	MODEL NUMBER									Approx. Packaged Weight	Delivered Pricing	Laminate Grade 2 add to list price
		Basic Model	Pull Option	Base	Top Color	Edge Color	Shell Color	Door Color	Lock Option	Lock Color			
 <p>Tall 3-Column Unit with Doors, Laminate Top and (27)3" Totes</p> <ul style="list-style-type: none"> Laminate top (1-1/4" with 74P edge) Single-Face only Totes included are translucent with no lid (not included on the 'empty' model) Unit ships assembled, including totes and rail sets; glides/casters are field installed Secure locking doors 	44 x 18 x 42"	RKT441842DRT/3T	<input type="checkbox"/>	<input type="checkbox"/>	<input type="checkbox"/>	<input type="checkbox"/>	<input type="checkbox"/>	<input type="checkbox"/>	<input type="checkbox"/>	<input type="checkbox"/>	211.1#	\$ 2845	\$ 19
 <p>Tall 3-Column Unit with Doors, Laminate Top and (12)6" Totes</p> <ul style="list-style-type: none"> Laminate top (1-1/4" with 74P edge) Single-Face only Totes included are translucent with no lid (not included on the 'empty' model) Unit ships assembled, including totes and rail sets; glides/casters are field installed Secure locking doors 	44 x 18 x 42"	RKT441842DRT/6T	<input type="checkbox"/>	<input type="checkbox"/>	<input type="checkbox"/>	<input type="checkbox"/>	<input type="checkbox"/>	<input type="checkbox"/>	<input type="checkbox"/>	<input type="checkbox"/>	199.8#	\$ 2615	\$ 19
 <p>Tall 3-Column Unit with Doors, Laminate Top and (15)3" and (6)6" Totes</p> <ul style="list-style-type: none"> Laminate top (1-1/4" with 74P edge) Single-Face only Totes included are translucent with no lid (not included on the 'empty' model) Unit ships assembled, including totes and rail sets; glides/casters are field installed Secure locking doors 	44 x 18 x 42"	RKT441842DRT/36T	<input type="checkbox"/>	<input type="checkbox"/>	<input type="checkbox"/>	<input type="checkbox"/>	<input type="checkbox"/>	<input type="checkbox"/>	<input type="checkbox"/>	<input type="checkbox"/>	201.1#	\$ 2790	\$ 19
 <p>Tall 3-Column Unit with Doors and Laminate Top-Empty</p> <ul style="list-style-type: none"> Laminate top (1-1/4" with 74P edge) Single-Face only Tote and rail sets must be ordered separately and installed on-site Unit ships assembled; glides/casters are field installed Secure locking doors 	44 x 18 x 42"	RKT441842DRT/XT	<input type="checkbox"/>	<input type="checkbox"/>	<input type="checkbox"/>	<input type="checkbox"/>	<input type="checkbox"/>	<input type="checkbox"/>	<input type="checkbox"/>	<input type="checkbox"/>	180.0#	\$ 2204	\$ 19

A B C D E F G H I

HOW TO ORDER

- Indicate the following information on order form:
- Quantity of each item.
 - Model number, including options. See "How To Build a Model Number".
 - Any special service required.

Note:

- The indicates that a choice is required.
- The absence of the indicates that no choice is required.
- Alpha-numeric characters in place of indicate that no other alternatives are available.

HOW TO BUILD A MODEL NUMBER

- A** Select basic model.
- B** Select pull option.
 - \$6** - Beveled pull Black
 - \$5** - Beveled pull Satin Chrome
- C** Select base option.
 - 4CW** - 4 black casters
 - 4GB** - 4 black glides
- D** Select top laminate surface. Refer to the **Product Color Options** page in this price list.
- E** Select edge color. Refer to the **Product Color Options** page in this price list.
- F** Select shell color. Refer to the **Product Color Options** page in this price list.
- G** Select front door color.

Refer to the **Product Color Options** page in this price list.

- H** Select lock option.
 - KS** - Key standard - 2 locks
 - NLC** - No lock core - 2 locks

I Select lock color. Refer to the **Product Color Options** page in this price list.

FINISH INFORMATION

Additional Laminate Offering

KI offers laminates beyond those offered in the standard offering. Laminates that are currently available in the program can be viewed in KI product specification tools. Requests to add laminates to the program can be submitted via the product modification request process. Please note, requests to add laminates to the program must include the laminate manufacturer's name, color/pattern number, and finish code. Edge options are limited to standard edge colors. If a matching edge is required, this will need to be requested through the product modification request process and may be subject to additional costs. Due to varying manufacturing processes and quality issues with some laminates, some requests may be denied. Extended lead times and minimum order quantities may apply on orders containing special laminates. Contact the product modification team for questions or additional information regarding special laminates and pricing.

SPECIAL SERVICES

Special Carton Marking



With specially marked information N/C

Shipping

Ships assembled, FOB Pembroke, ON K8A 0E1, freight prepaid. Freight class 100.

Specifications and prices are subject to change without prior notice.

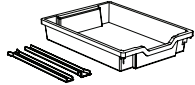

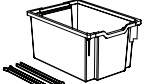
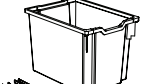
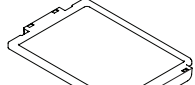
MODEL	W x D	MODEL NUMBER		Approx. Packaged Weight	Delivered Pricing
		Basic Model			
 <p>3"H Totes Kit (includes 6 translucent totes and rail sets)</p>		RKA3TKIT6		8.2#	\$ 213
RCKA					
 <p>6"H Totes Kit (includes 6 translucent totes and rail sets)</p>		RKA6TKIT6		11.2#	\$ 248
RCKA					
 <p>9"H Totes Kit (includes 6 translucent totes and rail sets)</p>		RKA9TKIT6		13.3#	\$ 309
RCKA					
 <p>12"H Totes Kit (includes 6 translucent totes and rail sets)</p>		RKA12TKIT6		17.5#	\$ 336
RCKA					
 <p>Tote Lids Kit (includes 6 translucent tote lids)</p>		RKALIDKIT6		3.3#	\$ 144
RCKA					

A

HOW TO ORDER

- Indicate the following information on order form:
- Quantity of each item.
 - Model number, including options. See "How To Build a Model Number".
 - Any special service required.

- Note:
- The indicates that a choice is required.
 - The absence of the indicates that no choice is required.
 - Alpha-numeric characters in place of indicate that no other alternatives are available.

HOW TO BUILD A MODEL NUMBER

- A** Select basic model.

SPECIAL SERVICES

Special Carton Marking

With specially marked information N/C

Shipping

Ships assembled, FOB Pembroke, ON K8A 0E1, freight prepaid. Freight class 100.

Specifications and prices are subject to change without prior notice.

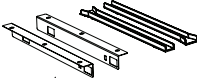
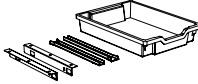
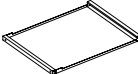

MODEL	MODEL NUMBER		Approx. Packaged Weight	Delivered Pricing
	Basic Model	Paint Color		
 Tote Storage Rails Only Kit (includes 12 rail sets) RCKA	RKARAILKIT12		2.60#	\$ 137
 Undersurface Rail kit (tote specified separately) • Mounting brackets are Starlight Silver Metallic • For installing undersurface without predrilled holes RCKA	RKAUSRKIT1		1.00#	\$ 71
 Undersurface Rail kit, with 3" Tote • Mounting brackets are Starlight Silver Metallic • For installing undersurface without predrilled holes RCKA	RKAUSR3TKIT1		2.20#	\$ 118
 Tote Storage Removeable Steel Shelf with Rail Set RCKA	RKATSSHELF	<input type="checkbox"/>	4.50#	\$ 59

A

B

HOW TO ORDER

- Indicate the following information on order form:
- Quantity of each item.
 - Model number, including options. See "How To Build a Model Number".
 - Any special service required.

- Note:
- The indicates that a choice is required.
 - The absence of the indicates that no choice is required.
 - Alpha-numeric characters in place of indicate that no other alternatives are available.

HOW TO BUILD A MODEL NUMBER

- A** Select basic model.
- B** Select paint color. Refer to the **Product Color Options** page in this price list.

SPECIAL SERVICES

Special Carton Marking





With specially marked information N/C

Shipping

Ships assembled, FOB Pembroke, ON K8A 0E1, freight prepaid. Freight class 100.

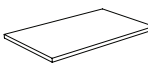
Specifications and prices are subject to change without prior notice.



	MODEL	W x D	MODEL NUMBER			Approx. Packaged Weight	Delivered Pricing	Laminate Grade 2 add to list price
			Basic Model	Top Color	Edge Color			
	Tote Storage Top 30Wx18D • Laminate top (1-1/4" with 74P edge)	30 x 18"	RKATTOP3018	<input type="checkbox"/> <input type="checkbox"/>	<input type="checkbox"/> <input type="checkbox"/>	19.4#	\$ 389	\$ 19
RCKA								
	Tote Storage Top 44Wx18D • Laminate top (1-1/4" with 74P edge)	44 x 18"	RKATTOP4418	<input type="checkbox"/> <input type="checkbox"/>	<input type="checkbox"/> <input type="checkbox"/>	28.4#	\$ 476	\$ 19
RCKA								
	Ruckus Storage Caster Kit (4 Black Casters)		RKA4CWKIT			2.0#	\$ 70	N/A
RCKA								
	Ruckus Storage Glide Kit (4 Black Glides)		RKA4GBKIT			1.5#	\$ 76	N/A
RCKA								

A **B** **C**

HOW TO ORDER

- Indicate the following information on order form:
- Quantity of each item.
 - Model number, including options. See "How To Build a Model Number".
 - Any special service required.

Note:

- The indicates that a choice is required.
- The absence of the indicates that no choice is required.
- Alpha-numeric characters in place of indicate that no other alternatives are available.

HOW TO BUILD A MODEL NUMBER

- A** Select basic model.
- B** Select top laminate surface. Refer to the **Product Color Options** page in this price list.
- C** Select edge color. Refer to the **Product Color Options** page in this price list.

SPECIAL SERVICES

Special Carton Marking

With specially marked information N/C

Shipping
Ships **assembled, FOB Pembroke, ON K8A 0E1, freight prepaid.** Freight class 100.

Specifications and prices are subject to change without prior notice.



MODEL	Features	MODEL NUMBER		Approx. Packaged Weight	Delivered Pricing
		Basic Model			
AC905	P-Series Keys • Double bit design • Range of 200 different core/key numbers available • Must specify lock number(s) requested when ordering cut key or lock core/key sets	Lock Core/2 Key Set - Satin Chrome	2.KP20522.SC	0.40#	\$ 16
		Lock Core/2 Key Set - Black	2.KP20522	0.40#	16
		Master Key	2.KP20550	0.20#	12
		Extractor Key	2.KP20551	0.20#	12
		Blank Key	2.KP20552	0.20#	3
		Cut Key	2.KP20557	0.20#	4

A

HOW TO ORDER

- Indicate the following information on order form:
1. Quantity of each item.
 2. Model number, including options. See "How To Build a Model Number".
 3. Any special service required.

- Note:
- The indicates that a choice is required.
 - The absence of the indicates that no choice is required.
 - Alpha-numeric characters in place of indicate that no other alternatives are available.

HOW TO BUILD A MODEL NUMBER

- A** Select basic model.

SPECIAL SERVICES

Special Carton Marking

With specially marked information N/C

Shipping

Ships **assembled, FOB Pembroke, ON K8A 0E1, freight prepaid.** Freight class 70.

Specifications and prices are subject to change without prior notice.

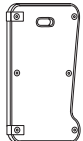

		MODEL NUMBER			
MODEL		Basic Model	Approx. Packaged Weight	Delivered Pricing	
 RKWB	Ruckus Whiteboard, Small • Dry-erase and tackable acoustic PET felt surfaces • Magnetic dots for attaching markers & other accessories • Leather straps for hanging on wall track and holding papers • Unique palette shape improves handling & positioning • Integrated handle. Hangs on undersurface bag hooks	16 x 12"	RKWB1612	2.0#	\$ 115
	Ruckus Whiteboard, Medium • Dry-erase and tackable acoustic PET felt surfaces • Magnetic dots for attaching markers & other accessories • Leather straps for hanging on wall track and holding papers • Unique palette shape improves handling & positioning • Integrated handle. Hangs on undersurface bag hooks	22 X 18"	RKWB2218	3.5#	\$ 162
 RKWB	Ruckus Whiteboard, Large • Dry-erase and tackable acoustic PET felt surfaces • Magnetic dots for attaching markers & other accessories • Leather straps for hanging on wall track and holding papers • Integrated handle	31 x 23"	RKWB3123	6.0#	\$ 318
	Ruckus Whiteboard, XL • Dry-erase and tackable acoustic PET felt surfaces • Magnetic dots for attaching markers & other accessories • Leather straps for hanging on wall track and holding papers • Integrated handle • Notched base permits foot clearance	71 x 23"	RKWB7123	16.0#	\$ 681

A

HOW TO ORDER

- Indicate the following information on order form:
- Quantity of each item.
 - Model number, including options. See "How To Build a Model Number".
 - Any special service required.

Note:

- The indicates that a choice is required.
- The absence of the indicates that no choice is required.
- Alpha-numeric characters in place of indicate that no other alternatives are available.

HOW TO BUILD A MODEL NUMBER

A Select basic model.

SPECIAL SERVICES

Special Carton Marking





With specially marked information N/C

Shipping

Ships assembled, FOB Bondue1, WI 54107, freight prepaid. Freight class 125.

Specifications and prices are subject to change without prior notice.

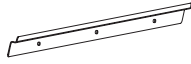

MODEL	MODEL NUMBER			Approx. Packaged Weight	Delivered Pricing
	Basic Model	Paint Color	Under Table Storage		
 RKWA Pivot Dock • Holds Medium and Large Ruckus Whiteboards upright for display or to create privacy. • Allows user to pivot Whiteboards 360 degrees • Clamps onto desk and table surfaces 3/4" to 1-1/4" thick	RKWADOCK	<input type="checkbox"/>		1.0#	\$ 52
 RKWA Widget • Stands Ruckus whiteboards up into a privacy or display mode • Props Ruckus whiteboards up into a drafting angle • Holds one standard and two fine tip sized markers (markers not included) • 100% post-consumer recycled PET felt	RKWAWIDGET			0.5#	\$ 11
 RKWA Wall Track 48" • Allows Ruckus whiteboards to be displayed or stored vertically on exterior walls • 48" length holds 1 to 3 Ruckus Whiteboards depending on size • Mounting hardware not included	RKWAWALLTRCK	<input type="checkbox"/>		1.5#	\$ 65
 RKWM Undersurface Hook • 1/4" wire rod, chrome finish • Field Installable, includes 2 screws • Holds whiteboards, bags and purses	RKWMUSHOOK			0.2#	\$ 9
 RKWA Mobile Display Cart • Two-sided cart, with two heights of display shelves • Display shelves hold Ruckus whiteboards of any size • Center shelf for storing ruckus whiteboards • Locking caster base • Shown with removable tote storage	RKWACART	<input type="checkbox"/>	<input type="checkbox"/>	100.0#	\$ 2030

A **B** **C**

HOW TO ORDER

- Indicate the following information on order form:
- Quantity of each item.
 - Model number, including options. See "How To Build a Model Number".
 - Any special service required.

Note: • The indicates that a choice is required.
 • The absence of the indicates that no choice is required.
 • Alpha-numeric characters in place of indicate that no other alternatives are available.

HOW TO BUILD A MODEL NUMBER

- A** Select basic model.
- B** Select paint color.
Refer to the **Product Color Options** page in this price list.
- C** Select under table storage.

NB	- No book storage
RT	- Removable storage tote; add \$51

SPECIAL SERVICES

Special Carton Marking

With specially marked information N/C

Shipping

Ships assembled, FOB Bondue1, WI 54107, freight prepaid. Freight class 70.

Specifications and prices are subject to change without prior notice.



1330 BELLEVUE STREET
GREEN BAY, WI 54302
800.424.2432 / KI.COM

KI is a trusted expert for furniture and wall systems around the globe.
USA | CANADA | MEXICO | UK | EUROPE | ASIA | MIDDLE EAST
© 2026 Krueger International, Inc. All Rights Reserved.