



TATTOO[®] COLLECTION

PRICE LIST

EFFECTIVE APRIL 13, 2026
800.424.2432

Contents

Refer to KI Terms & Conditions document or visit ki.com.



Contents

Refer to KI Terms & Conditions document or visit ki.com.

Fabric Yardage Pricing	3
-------------------------------	---

Ordering Customer's Own Material (C.O.M.) Upholstery	
Information	4

Tattoo™ Screens	
Technical Information	5
Product Color Options	9

Tattoo™ Flex Screens	
Monolithic Flex Screen with Magnetic Dry-Erasable Steel Core	10
Monolithic Flex Screen with Polyester Felt Core	11
Monolithic Flex Screen with Acrylic Core	12
Monolithic Flex Screen with Thermally-Fused Laminate Core	13
Monolithic Flex Screen with Fluted Polycarbonate Core	14
Monolithic Flex Screen with Tackable Fabric Core	15
Segmented Flex Screen with Thermally-Fused Laminate Lower, Magnetic Dry-Erasable Steel Upper Core	17
Segmented Flex Screen with Thermally-Fused Laminate Lower and Upper Core	19
Segmented Flex Screen with Thermally-Fused Laminate Lower, Polyester Felt Upper Core	21
Segmented Flex Screen with Thermally-Fused Laminate Lower, Fabric Upper Core	23
Segmented Flex Screen with Thermally-Fused Laminate Lower, Fluted Polycarbonate Upper Core	25
Segmented Flex Screen with Thermally-Fused Laminate Lower, Acrylic Upper Core	27
Segmented Flex Screen with Polyester Felt Lower, Magnetic Dry-Erasable Steel Upper Core	29
Segmented Flex Screen with Polyester Felt Lower and Thermally-Fused Laminate Upper Core	31
Segmented Flex Screen with Polyester Felt Lower and Upper Core	33
Segmented Flex Screen with Polyester Felt Lower, Fabric Upper Core	35
Segmented Flex Screen with Polyester Felt Lower, Fluted Polycarbonate Upper Core	37
Segmented Flex Screen with Polyester Felt Lower, Acrylic Upper Core	39
Segmented Flex Screen with Fabric Lower, Magnetic Dry-Erasable Steel Upper Core	41
Segmented Flex Screen with Fabric Lower, Thermally-Fused Laminate Upper Core	43
Segmented Flex Screen with Fabric Lower, Polyester Felt Upper Core	45
Segmented Flex Screen with Fabric Lower and Upper Core	47
Segmented Flex Screen with Fabric Lower, Fluted Polycarbonate Upper Core	49
Segmented Flex Screen with Fabric Lower, Acrylic Upper Core	51

Tattoo™ Spine Screens	
Powered Monolithic Spine Screen with Magnetic Dry-Erasable Steel Core	53
Powered Monolithic Spine Screen with Thermally-Fused Laminate Core	55
Non-Powered Monolithic Spine Screen with Magnetic Dry-Erasable Steel Core	57
Non-Powered Monolithic Spine Screen with Thermally-Fused Laminate Core	59
Trim Kits for Spine Screens	61
Electrical - Top Infeed Kits 10-Wire System 6-Circuit	63
Electrical - Base Infeed Kits 10-Wire System 6-Circuit	64
Receptacle Infeed	65
Electrical - Jumpers and Receptacles	66
Electrical - Plates	67

Tattoo™ Screens Accessories	
Screen Topper Kits	68
Magnetic Polyester Felt Inserts	69
Magnetic Storage Pieces and Magnetic Tackboard Tiles	71
Accessories	72

Tattoo™ Storage	
General Information	73
Ordering Customer's Own Material (C.O.M.) Upholstery	77
Product Color Options	78
Pedestals	79
Towers	80
Vanity with Laminate Top	82
Vanity with Steel Top	83
Low Cupboard	85
Chest	87
Accessories	88

Tattoo™ Seating	
General Information	90
Ordering Customer's Own Material (C.O.M.) Upholstery	93
Product Color Options	95
Slim Corner	96

Slim Seat	98
Slim Seat with Table	99
Ottoman	101
Occasional Table	102
Accessories	103

Tattoo™ Tables	
General Information	104
Product Color Options	106
Column Base - 18" High	107
Column Base - 29" High	108

Toggle® Tables	
General Information	109
Product Color Options	117

Toggle® T-Leg Tables	
Fixed Base	118
Dual Motor Electric Base	119

Toggle® C-Leg Tables	
Dual Motor Electric Base	120

Toggle® Square Shoe Tables	
Triple Motor Electric Base	121

Toggle® Tables	
Accessories	122

WorkUp® Tables	
General Information	124
Product Color Options	130
Fixed Height	131
Crank Adjustable Height (Sit - Stand)	132
Counter Balance Adjustable Height	133
Accessories	135

Universal Height Adjustable Screens	
General Information	136
Product Color Options	137
Felt Panels	138

Accessories	
Monitor Arms	139



Yardage	Grade	List Price Per Yard
1	C	\$ 49
1	D	\$ 64
1	E	\$ 78
1	F	\$ 100
1	G	\$ 122
1	H	\$ 144
1	I	\$ 178
1	J	\$ 222
1	K	\$ 289
1	L	\$ 333
1	M	\$ 422



Customer's Own Material ■

Specifications Form

January 2023

How to Specify

As a standard procedure, KI applies seating upholstery as swatched by the textile distributor. Reference distributor's website. Upholstery that is required to be applied differently than is swatched, will need a Product Modification Request written specifying the direction the upholstery is to be applied.

Seating upholstery requiring specific positioning of intricate patterns or patterns repeats on seats and backrests, will need a Product Modification Request written including a sketch noting the specific requirements, as in Diagram A.

C.O.M. must be supplied in continuous yardage.

Yardage requirements listed in price list are based on plain goods 54" wide. Fabrics less than 54" wide, or those requiring matching (stripes, plaids, prints, large patterns) will require additional yardage based on the fabric used and the item ordered. Consult matrix below for additional yardage needed.

C.O.M. INCREASE MATRIX (yardage matrix is also applicable to any reservations of KI Ingrade, Pallas, or K.O.M. upholsteries).

This table is a general guide.

FABRIC WIDTH	PLAIN FABRIC	UNDER 7"	8"-13"	14"-21"	22"-27"	28"-33"	34"-40"	41"-48"
	FABRIC	REPEAT	REPEAT	REPEAT	REPEAT	REPEAT	REPEAT	REPEAT
54"	0	20%	25%	30%	45%	55%	70%	80%
51"-53"	15%	25%	30%	35%	50%	60%	80%	90%
48"-50"	20%	30%	35%	40%	55%	65%	85%	95%
45"-47"	30%	45%	50%	55%	60%	80%	90%	100%
36"-44"	50%	65%	70%	75%	80%	100%	110%	120%

Fabric with double repeat: If using a fabric with a double repeat, please follow this formula: take the total amount of the larger and half of the smaller repeat; add together to find the correct overall repeat. Example: 10" vertical with 14" horizontal would be $14 + 5 = 19$.

If fabric comes in on multiple rolls, one additional yard per roll needs to be added to the yardage requirement.

Leather hides must be a minimum of 50 square feet of usable material. The outer edges cannot be calculated as square feet or yardage. To determine square footage, multiply unit yardage by 18 square feet to obtain the total square footage required per unit.

For exact production yardage requirements, call 1-800-424-2432, ext. 2707.

Production

Customer's upholstery must be approved prior to acceptance for production.

After approval, a memo swatch of the C.O.M. from the textile distributor must accompany the order. KI assumes no responsibility for wear, defects, or performance of C.O.M. or K.O.M. upholstery.

C.O.M. not received into the appropriate facility 3 weeks prior to acknowledged delivery date may go on hold. See KI C.O.M. Shipping Location listing for the correct facility address by product.

All C.O.M. must be labeled as follows:

1. Name and address
2. Your purchase order number
3. Our style number to which fabric is to be applied
4. Supplier name and fabric name, number, and color

ALL C.O.M. Shipments must be prepaid. Collect shipments will be refused.

Testing

When KI requires testing, actual yardage to upholster one chair may be required. The C.O.M. Specialist will confirm model and fabric testing requirements when applicable.

Approved test samples will be applied to the order or will be held for 6 months. After 6 months, the sample will no longer be applied to your order. For all product testing, send fabric samples to the manufacturing facility. See KI C.O.M. Shipping Location listing for the correct facility address by product.

Diagram A

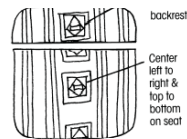

ALL C.O.M. Shipments must be prepaid. Collect shipments will be refused.

Treated Materials

If C.O.M. requires processing such as a stain resistance treatment or acrylic backing, it may shrink. To prevent delays in delivery or back ordering due to shrinkage, please have your processor verify measurement after processing and assure adequate yardage shipped.

Split Orders

If a portion of the shipment which does not require C.O.M. application is to be processed and shipped early, KI will enter the order immediately at your request. These split shipments are subject to minimum order changes.

Excess Upholstery Material

KI will dispose of excess upholstery material at the time of shipment unless expressly requested to return it with the product shipment.

Cancelled or Changed Orders

KI assumes no responsibility for extra C.O.M. due to a change of upholstery or cancellation of an order. If it the customer's responsibility to arrange for return of the material.

Contact the C.O.M. Specialist at 1-800-424-2432, ext. 2707, with questions or to request a split order



Spine Screens

Spine screens allow for a mechanical connection between screen frames and include optional 10-wire power. Spine screens are available with the monolithic core style only, made of magnetic dry-erasable steel or thermally-fused laminate, and include adjustable-height feet to accommodate installation (accommodate uneven floor heights). Spine screens ship partially assembled.

Spine screens are available in the following dimensions:

- Widths: 48", 54", 60", 66", 72", 78", 84", 90", 96"
- Heights: 48", 54"

Flex Screens

Flex screens offer freestanding, user-controlled, space dividing screens in a variety of sizes and finishes, and are non-powered only. Flex screens are offered in monolithic and segmented styles and can be specified with adjustable feet or flat/bridge style feet. The flat/bridge style feet allow for 90° intersections and can also nest with adjustable height feet. Flex screens ship fully assembled, except when a horizontal topper is specified.

Flex screens are available in the following dimensions:

- Widths: 42", 48", 54", 60", 66", 72", 78", 84", 90", 96"
- Heights: 42", 48", 54", 60"

Note: 48" and 54" high flex screens have optional segmentation available at 29" from the floor. 42" flex screens are always monolithic. 60" high flex screens are always segmented.

All flex screens may be specified with horizontal toppers, which attach to the top of the screen when a top cap is not specified.

Frame Construction

All Tattoo spine & flex screen frames are constructed of 2½" by 1¼" aluminum extrusions finished with powder-coat paint. Frames are assembled in the factory (feet and base raceway trim are not installed on spine screens) and may consist of the following:

Base Raceway Trim (for spine screens)

Aluminum extrusions finished in powder-coat paint, measuring 6" tall by screen length, with receptacle and data cutouts per specification. Optional data cutouts are sized 2.88" width by 1.82" height with two holes to accommodate a #6-32 screw.

Wireway Mounting Bracket (for spine screens)

16-gauge formed steel, connects the 10-wire rigid wireway into the frame extrusion at the top of the base raceway area.

Floor Channel (for spine screens)

14-gauge formed steel finished in powder-coat paint, measuring 2½" wide by 1¼" tall, spanning the length of the screen and making up the bottom of the base raceway area.

Bridge & Flat Plate foot (for flex screens)

¼" thick steel with a footprint of 2¼" x 15" finished in powder-coat paint. Each foot includes a pair of 1" diameter non-adjustable nylon glides, adhered into counter-bores in the bottom of the foot. Each flex screen as specified ships with one flat and one bridge foot. Not available on spine screens.

Frame Construction (cont.)

Adjustable Glide Feet

Constructed of cast aluminum with a footprint of 2¼" x 15" finished in powder-coat paint. Feet pair is standard on spine screens and may be ordered on flex screens.

Adjustable Glide (for spine & flex screen adjustable glide feet)

½" diameter nylon base glides are threaded into the foot and allow for 1" of adjustability.

Trim Kits

All spine screens require a trim kit which is specified by size of screen, finish selection and power infeed location, if applicable. Trim kits include vertical caps, corner caps, attachment clips and electrical infeed conditions. Horizontal top caps are also included standard with spine screens and factory installed. When a topper is desired on a specific screen "no top cap" is specified. Trim caps are formed of extruded aluminum and are finished with powder-coat paint. Installation of horizontal and vertical trim caps require no tools. Removal of trim caps require a flat prybar. Flex screens come fully trimmed and do not require specification of additional trim kits.

Core Styles

Monolithic

Monolithic panels are dual-sided and available in a variety of substrate and finish options. Spine screens are always monolithic. 42" high flex screens are always monolithic.

Segmented

Segmented panels are available in a variety of substrate and finish options. Segmented screens feature a 29" segmentation height, with specified upper and lower cores. 48" and 54" high flex screens have optional segmentation available at 29" from the floor. 60" high flex screens are always segmented.

Core Materials

Fabric Cores

Fabric panel cores are constructed of LDF (low density fiberboard), upholstered and glued on both sides using water-based spray adhesive. Nominal thickness is ½". Fabric cores are fully tackable.

Fluted Polycarbonate Cores

Fluted polycarbonate cores are 10 mm multiwall polycarbonate and are available with a clear finish. Clear extruded PVC gaskets are used between the core and supporting frame.

Magnetic Dry-Erasable Steel Cores

Magnetic dry-erasable steel cores are constructed of 28-gauge steel panels, laminated on both sides of a Fibrex core material. The steel panels include a polyester outer film creating a writable and dry-eraseable surface. Overall thickness is nominal ¼". Clear extruded PVC gaskets are used between core and supporting frame.

Thermally-Fused Laminate Cores

Thermally-fused laminate cores are constructed of laminate, adhered by thermally-fusing both sides to particleboard. Overall thickness is nominal ½".

Acrylic Cores

Acrylic cores are constructed of ¼" thick, Acrylite Satinice material with a velvet texture, a very fine satin surface on both sides and are available in a variety of colors. Clear extruded PVC gaskets are used between core and the supporting frame.

Polyester Felt Cores

Polyester felt cores are constructed from ½" thick, 100% polyester felt and are available in a variety of colors. The cores have a density of 0.5 lb/ft² and is sound absorbing tested to ASTM C423 with an NRC rating of .44 when using no air gap (A Mount testing method) and an NRC rating of .81" with 2" air gap. The polyester felt is in accordance with ASTM-E84 and achieve a Class A Flame Spread. Polyester felt cores are fully tackable.



Horizontal Toppers

Toppers are available for use on spine & flex screens and take the place of the horizontal top cap. Specify "no top cap" on screens when a horizontal topper is to be used. Horizontal toppers are 12" in height and are specified to match the length of a corresponding screen. Extruded aluminum top caps hold the toppers in place without the use of fasteners.

Acrylic Horizontal Topper

Acrylic toppers are 1/4" thick Acrylite Satinice material with satin surface on both sides, and are offered in a variety of colors. Acrylic toppers have a slight bull-nosed edge and a 1/4" radius on the top corner. The length of acrylic topper is consistent with the length of the screen. Cork gaskets are used between the acrylic and aluminum top cap.

Polyester Felt Horizontal Topper

Polyester felt toppers are constructed from 1/2" thick, 100% polyester felt and are available in a variety of colors. The felt cores have a density of 0.5 lb/ft² and is sound absorbing tested to ASTM C423 with an NRC rating of .44 when using no air gap (A Mount testing method) and an NRC rating of .81" with 2" air gap. The polyester felt is in accordance with ASTM-E84 and achieve a Class A Flame Spread. Felt toppers have square edges and corners. The length of felt dividers is consistent with the length of the screen.

Electrical

Refer to the Planning Guide for information on product specification.

Optional Power - 810 Electrical

Optional power is offered on the Tattoo powered spine screens only. Power is 810 electrical system, for the US standard electrical system. 10-wire rigid wireways are factory mounted to powered screens.

Power is supplied through a 6-2-2 configuration:

- (6) hot wires
- (2) shared oversized neutral wires
- (2) ground wires - one isolated ground and one building ground

Compliance

Tattoo spine screen system is a UL Listed Office Furnishing per standard UL 1286. Non-powered flex screens are not included in this listing. Spine screens meet all applicable ANSI/BIFMA X5.6 - Panel Systems.

Base Infeeds (Power and/or Data)

The Spine screen's electrical system allows for base infeed to enter in-line, at end-of-run, or at a receptacle opening on the screen's base raceway trim. End-of-run base infeed kits utilize either a base infeed spacer or a base infeed vertical trim. In-line base infeed kits use a base infeed spacer where power and/or data enters from the side. Base infeed power enters into the bottom of the screen system through a cutout in the appropriate end or side trim. Receptacle infeed enters along the side of the screen and occupies the space of one receptacle cutout. Power for base infeed utilizes an 8' long, 1/2" liquid-tight flexible conduit, containing ten wires and having a modular connector end for the 810 electrical system. Data wires can enter the base of the screen through the cutout in the bottom of the trim, or through an opening in the bottom of the screen's floor channel. Data cabling, mounting plates and accessories are not provided by KI. **Note:** Data mounting plates must have ports oriented at 45°.

Top Infeeds (Power and/or Data)

Top infeed includes a 3" square, 120" long extruded aluminum power and data pole to bring power and/or data in from at, or above, ceiling level. A 5' long extension pole with splice plate is available for taller ceilings. Top infeed kits may be specified as end-of-run, or in-line. Power for top infeed utilizes a 12' long (18' long with extension option) 1/2" liquid-tight flexible metal conduit containing ten wires and having a modular connector end for the 810 electrical system. Data wires enter the pole the in the same manner as power. Data cabling, mounting plates and accessories are not provided by KI. **Note:** Data mounting plates must have ports oriented at 45°.

TECHNICAL SPECIFICATIONS

Electrical (cont.)

10-Wire Rigid Wireways

Each powered screen requires the use of 10-wire rigid wireways to provide power to receptacles. 10-wire rigid wireways are factory installed onto the bottom frame of the screen. Each screen includes two wireways, one at each end with a 10-wire power jumper in between. On both sides of each wireway, at each end of a powered screen, is a receptacle (ordered separately), plugged into the rigid wireway. The centerline of each receptacle is 12 inches from the end of each screen. The rigid wireway design allows for snap-connection of one screen's wireway to that of another screen using common 10-wire screen-to-screen jumpers (ordered separately).

10-Wire Pass-Through Screen-to-Screen Jumpers

The electrical system provides a method of passing power from one powered screen through a non-powered screen to the powered 10-wire rigid wireway of the next screen. The pass-through screen does not include wireways and receptacles. 10-Wire pass-through screen-to-screen jumpers (ordered separately) are required to connect adjacent in-line screen wireways.

10-Wire Screen-to-Screen Jumpers

10-wire screen-to-screen jumpers feature modular connector ends with nylon mesh casing over wires and are specified separate from the screens.

10-Wire Duplex Receptacles

10-wire duplex receptacles for the modular electrical system feature injection molded components, which snap fit into the 10-wire rigid wireways of the screens. The rated capacity of the duplex receptacles is 15 amps in a 6-2-2 circuit configuration.

Bezels & Filler Plates

Bezels and filler plates are molded in nylon and are available in a variety of colors. Bezels and filler plates are included with Tattoo spine screen base covers when power is specified and are field-installed.

Data Cover Plates

Data cover plates are 2 1/4" x 4 1/2" steel plates finished in powder-coat paint. Each plate includes attachment hardware and are field installed. Data cover plates are specified separate from the screens.

Electrical Infeed - New York City

The City of New York, 10-wire power infeed consists a service entry box sized for the 10-wire power distribution system. Building source power wires enter the box and are hard wired to the 10-wire ends in the box. Power exits the box through flexible conduit with a 10-wire modular connector end. The connector end feeds to the factory-installed 10-wire power distribution system. All wiring, connections, accessories and installation are to be performed by a licensed electrician.

Electrical - Hardwired

Hardwired electrical components may be specified for use in installations where required by local code (such as Chicago). Tattoo screens so specified are shipped only with receptacle enclosures, are absent of other electrical components, but are ready to receive field-added electrical components to the receptacle enclosure by the customer's licensed electrician. Receptacle enclosures are constructed of 14-gauge galvanized metal in accordance with the National Electrical Code. 4.31" width by 2.44" height openings are located asymmetrical on both sides of the screen for dual-sided applications. Left-hand openings (when facing screen) are located 16" on center from left edge of screen. Right-hand opening (when facing screen) is located 6" on center from right-hand edge of screen. Infeeds, wiring, connections and all other electrical accessories are provided and connected by a licensed electrician.



TECHNICAL SPECIFICATIONS

Accessories

Polyester Felt Magnetic Inserts

Polyester felt magnetic inserts are constructed from 1/2" thick tackable, 100% polyester felt and are available in a variety of colors. The inserts have a density of 0.5lb/ft² and are sound absorbing with an acoustic rating of 0.45-0.90 NRC (acoustic range varies due to size and space relation). The panels are in accordance with ASTM-E84 and achieve a Class A Flame Spread. Magnetic strips are applied to one side using adhesive. Nominal thickness is 1/2". Not offered on 42" height screens and can only be used on screens with a dry-erasable steel core.

Widths: 40", 46", 52", 58", 64", 69", 75", 81", 87" & 93"
Heights: 39" & 45"

Patterned Polyester Felt Magnetic Inserts

Patterned polyester felt magnetic inserts are constructed from two layers of 100% polyester felt and are available in a variety of colors. The inserts have a density of 0.12lb/ft² are sound absorbing with an acoustic rating of 0.35-0.90 NRC (acoustic range varies due to size and space relation). Magnetic strips are applied to one side using adhesive. Nominal thickness is 5/8". Not offered on 42" height screens and can only be used on screens with a dry-erasable steel core.

Widths: 40", 46", 52", 58", 64", 69", 75", 81", 87" & 93"
Heights: 39" & 45"

Magnetic Tackboard Tiles

Magnetic tackboard tiles are constructed of a multilayer fiberglass core upholstered on one side using adhesive. Magnetic strips are applied to the non-upholstered side using adhesive and can only be used on screens with a dry-erasable steel core. Nominal thickness is 1/2".

Sizes Offered: 18" x 18", 18" x 24" & 24" x 24".

Coat Hook

Formed 11-gauge bent steel powder-coat painted hook in a variety of colors. Coat hook comes with an aluminum glide which is attached to the hook using a 1/2" cap screw. The aluminum glide fits into an access opening in top frame of spine & flex screens allowing the coat hook to slide into location.

Sliding Dual-Purpose Board

The sliding boards are constructed of a fiberglass core, upholstered on one side and adhered to a 28-gauge steel pan on the other. The steel includes a polyester film creating a writable and dry-eraseable surface. The core is framed two sides by extruded aluminum frames. Attached nylon glide fits into access opening in top frame of spine & flex screens allowing slide panel to slide into location.

Dimensions: 24" width by 39" height by 1/2" depth.

DIMENSIONS

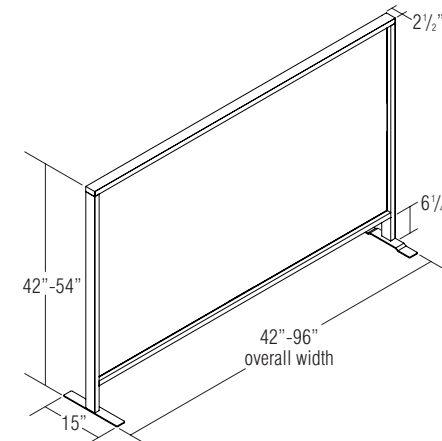

Monolithic Flex Screen with Flat/Bridge Feet

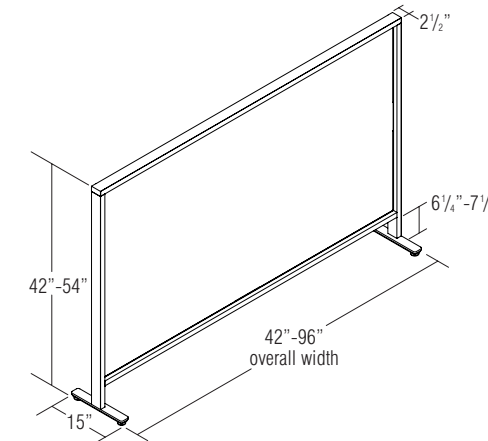

Monolithic Flex Screen with Adjustable Glide Feet

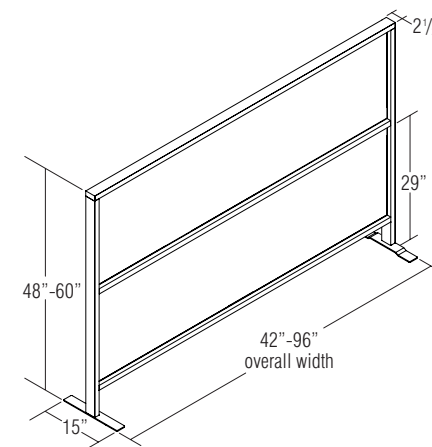

**Segmented Flex Screen with Flat/Bridge Feet
(also available with adjustable glide feet)**

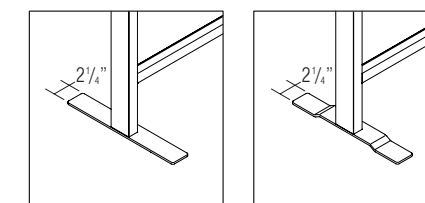

Flat Plate Foot

Bridge Plate Foot

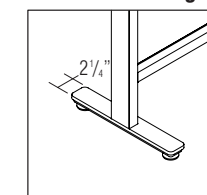

Adjustable Glide Foot



DIMENSIONS

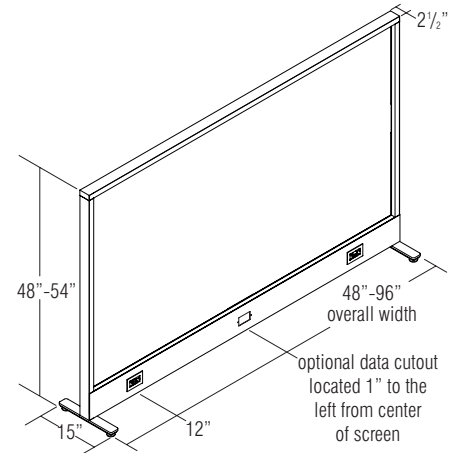

Spine Screen with 10-Wire Power & Data

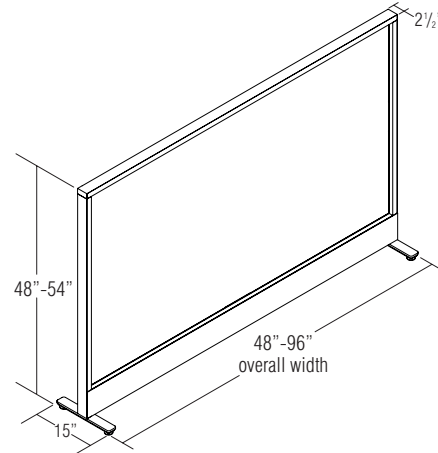

Spine Screen No-Power

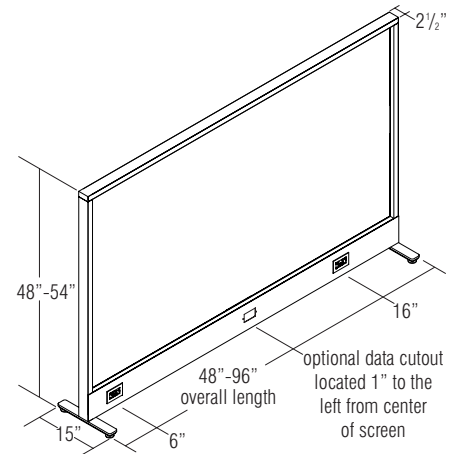

Spine Screen with Hardwired Electrical (Chicago Code) & Data

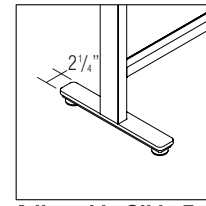

Adjustable Glide Foot



Polyester Felt for Monolithic Core and Magnetic Insert Color

Dandelion	FTDD
Fawn	FTFW
Flannel	FTFN
Heather	FTHR
Lava	FTLV
Mallard	FTML
Midnight Blue	FTMB
Pepper	FTPR
Spring	FTSG
Tidal Wave	FTTW

Lower Polyester Felt for Segmented Core Color

Dandelion	LFTDD
Fawn	LFTFW
Flannel	LFTFN
Heather	LFTHR
Lava	LFTLV
Mallard	LFTML
Midnight Blue	LFTMB
Pepper	LFTPR
Spring	LFTSG
Tidal Wave	LFTTW

Upper Polyester Felt for Segmented Core Color

Dandelion	UFTDD
Fawn	UFTFW
Flannel	UFTFN
Heather	UFTHR
Lava	UFTLV
Mallard	UFTML
Midnight Blue	UFTMB
Pepper	UFTPR
Spring	UFTSG
Tidal Wave	UFTTW

Patterned Polyester Felt for Magnetic Inserts Color

Dandelion foreground/Flannel background	FTDDFN
Fawn foreground/Flannel background	FTFWFN
Flannel foreground/Flannel background	FTFNFN
Heather foreground/Flannel background	FTHRFN
Lava foreground/Flannel background	FTLVFN
Midnight Blue foreground/Flannel background	FTMBFN
Spring foreground/Flannel background	FTSGFN
Dandelion foreground/Heather background	FTDDHR
Fawn foreground/Heather background	FTFWHR
Flannel foreground/Heather background	FTFNHR
Heather foreground/Heather background	FTHRHR
Lava foreground/Heather background	FTLVHR
Midnight Blue foreground/Heather background	FTMBHR
Spring foreground/Heather background	FTSGHR
Dandelion foreground/White background	FTDDWH
Fawn foreground/White background	FTFWWH
Flannel foreground/White background	FTFNWH
Heather foreground/White background	FTHRWH
Lava foreground/White background	FTLVWH
Midnight Blue foreground/White background	FTMBWH

Spring foreground/White background

Acrylic Color

Cloud Acrylic	ACD
Colorless Acrylic	ACS
Laguna Acrylic	ALA
Sunshine Acrylic	ASE
Tomato Acrylic	ATT

Frame/Trim & Trim Kit Color

Black	BL
Blue Grey	GR
Bronze Metallic	ZM
Cayenne	CY
Champagne Metallic	CM
Cool Grey	CG
Cottonwood	CO
Earthen Clay	EY
Espresso Metallic	EX
Everglade Shade	EV
Flannel	FN
Glitz Metallic	GZ
Hazy Jade	HJ
Honey Bee	HY
Light Tone	LG
Mardi Gras	MG
Misty Brown	MY
Nemo	NE
Nordic	ND
Purple Haze	PH
Rainforest	RQ
Raw Jasper	RJ
Rubber Ducky	RK
Sand	SA
Starlight Silver Metallic	SX
Surf's Up	SP
Tarragon	TQ
Twilight Shadow	TI
Ultra Blue	UB
Warm Grey	WG
Zesty Lime	ZL

Thermally-Fused Laminate Monolithic Core Color

Cherry Storm	LCX
Florence Walnut	LFC
Italian Silver Ash	LIT
Kensington Maple	LKM
River Cherry	LRY

Thermally-Fused Laminate Lower Segment Core Color

Cherry Storm	LLCX
Florence Walnut	LLFC
Italian Silver Ash	LLIT
Kensington Maple	LLKM
River Cherry	LLRY

Thermally-Fused Laminate Upper Segment Core Color

Cherry Storm	ULCX
Florence Walnut	ULFC

FTSGWH

Italian Silver Ash	ULIT
Kensington Maple	ULKM
River Cherry	ULRY

Electrical Floor Infeed Color

Black	IBL
Blue Grey	IGR
Light Tone	ILG
Sand	ISA
Warm Grey	IWG

Receptacle Color

Black	BL
Blue Grey	GR
Cool Grey	CG
Cottonwood	CO
Light Tone	LG
Misty Brown	MY
Sand	SA
Warm Grey	WG

Controlled Receptacle Color

Black	BL
Light Tone	LG
Sand	SA
Warm Grey	WG

Bezel Color

Black	BBL
Cool Grey	BCG
Cottonwood	BCO
Blue Grey	BGR
Light Tone	BLG
Misty Brown	BMV
Sand	BSA
Warm Grey	BWG

Filler and Data Plate Color

Black	BL
Blue Grey	GR
Cool Grey	CG
Cottonwood	CO
Light Tone	LG
Misty Brown	MY
Sand	SA
Warm Grey	WG

Receptacle Infeed-Spacer Kit Color

Black	BL
Blue Grey	GR
Light Tone	LG
Sand	SA
Warm Grey	WG

Coat Hook & Data Cover Plate Color

Black	BL
Blue Grey	GR
Bronze Metallic	ZM
Cayenne	CY
Champagne Metallic	CM

Cool Grey	CG
Cottonwood	CO
Earthen Clay	EY
Espresso Metallic	EX
Everglade Shade	EV
Flannel	FN
Glitz Metallic	GZ
Hazy Jade	HJ
Honey Bee	HY
Light Tone	LG
Mardi Gras	MG
Misty Brown	MY
Nemo	NE
Nordic	ND
Purple Haze	PH
Rainforest	RQ
Raw Jasper	RJ
Rubber Ducky	RK
Sand	SA
Starlight Silver Metallic	SX
Surf's Up	SP
Tarragon	TQ
Twilight Shadow	TI
Ultra Blue	UB
Warm Grey	WG
Zesty Lime	ZL

Magnetic Storage Pieces Colors

White	W
Includes (Binder Bin, File Bin, Low Bin and Pencil Cup).	

Magnetic Shelf

White	W
-------	---

Finish Cards

View color swatches for items listed within this document.

- [Paints](#)
- [Wood/Veneer](#)
- [Molded Edges](#)
- [Hard Plastics](#)
- [Plastics/Poly](#)
- [Laminates](#)
- [Edge Styles](#)
- [Glass](#)

Certain options referenced may not be available on GSA Schedule.

Tattoo™ Flex Screens

Monolithic Flex Screen with Magnetic Dry-Erasable Steel Core



Tattoo™ Flex Screens

Monolithic Flex Screen with Magnetic Dry-Erasable Steel Core

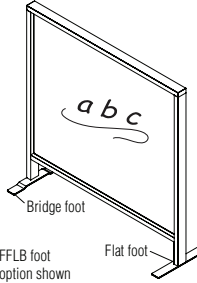
MODEL	MODEL NUMBER				Approx. Packaged Weight	Delivered Pricing
	Basic Model	Foot Option	Top Cap Style	Frame/Trim Color		
 <p>Monolithic Flex Screen with Magnetic Dry-Erasable Steel Core - 42" H</p> <ul style="list-style-type: none"> Flex screen assembly includes aluminum powder-coated frame, core material, all trim, and feet Steel core is dry-erasable and magnetic Specify adjustable glide feet, or non-adjustable flat/bridge feet Non-powered with elevated base; no wire management Fully assembled; includes all trim Slotting under upper trim accepts screen-hung accessories 	TFME4242	<input type="checkbox"/> <input type="checkbox"/> <input type="checkbox"/> <input type="checkbox"/>	<input type="checkbox"/>	<input type="checkbox"/> <input type="checkbox"/>	78.00#	\$ 1361
	TFME4842	<input type="checkbox"/> <input type="checkbox"/> <input type="checkbox"/> <input type="checkbox"/>	<input type="checkbox"/>	<input type="checkbox"/> <input type="checkbox"/>	85.00#	1380
	TFME5442	<input type="checkbox"/> <input type="checkbox"/> <input type="checkbox"/> <input type="checkbox"/>	<input type="checkbox"/>	<input type="checkbox"/> <input type="checkbox"/>	92.00#	1527
	TFME6042	<input type="checkbox"/> <input type="checkbox"/> <input type="checkbox"/> <input type="checkbox"/>	<input type="checkbox"/>	<input type="checkbox"/> <input type="checkbox"/>	99.00#	1551
	TFME6642	<input type="checkbox"/> <input type="checkbox"/> <input type="checkbox"/> <input type="checkbox"/>	<input type="checkbox"/>	<input type="checkbox"/> <input type="checkbox"/>	106.00#	1690
	TFME7242	<input type="checkbox"/> <input type="checkbox"/> <input type="checkbox"/> <input type="checkbox"/>	<input type="checkbox"/>	<input type="checkbox"/> <input type="checkbox"/>	113.00#	1717
	TFME7842	<input type="checkbox"/> <input type="checkbox"/> <input type="checkbox"/> <input type="checkbox"/>	<input type="checkbox"/>	<input type="checkbox"/> <input type="checkbox"/>	120.00#	1847
	TFME8442	<input type="checkbox"/> <input type="checkbox"/> <input type="checkbox"/> <input type="checkbox"/>	<input type="checkbox"/>	<input type="checkbox"/> <input type="checkbox"/>	127.00#	1884
	TFME9042	<input type="checkbox"/> <input type="checkbox"/> <input type="checkbox"/> <input type="checkbox"/>	<input type="checkbox"/>	<input type="checkbox"/> <input type="checkbox"/>	134.00#	2003
	TFME9642	<input type="checkbox"/> <input type="checkbox"/> <input type="checkbox"/> <input type="checkbox"/>	<input type="checkbox"/>	<input type="checkbox"/> <input type="checkbox"/>	141.00#	2029
<p>Monolithic Flex Screen with Magnetic Dry-Erasable Steel Core - 48" H</p> <ul style="list-style-type: none"> Flex screen assembly includes aluminum powder-coated frame, core material, all trim, and feet Steel core is dry-erasable and magnetic Specify adjustable glide feet, or non-adjustable flat/bridge feet Non-powered with elevated base; no wire management Fully assembled; includes all trim Slotting under upper trim accepts screen-hung accessories 	TFME4248	<input type="checkbox"/> <input type="checkbox"/> <input type="checkbox"/> <input type="checkbox"/>	<input type="checkbox"/>	<input type="checkbox"/> <input type="checkbox"/>	85.00#	\$ 1380
	TFME4848	<input type="checkbox"/> <input type="checkbox"/> <input type="checkbox"/> <input type="checkbox"/>	<input type="checkbox"/>	<input type="checkbox"/> <input type="checkbox"/>	93.00#	1415
	TFME5448	<input type="checkbox"/> <input type="checkbox"/> <input type="checkbox"/> <input type="checkbox"/>	<input type="checkbox"/>	<input type="checkbox"/> <input type="checkbox"/>	101.00#	1549
	TFME6048	<input type="checkbox"/> <input type="checkbox"/> <input type="checkbox"/> <input type="checkbox"/>	<input type="checkbox"/>	<input type="checkbox"/> <input type="checkbox"/>	109.00#	1577
	TFME6648	<input type="checkbox"/> <input type="checkbox"/> <input type="checkbox"/> <input type="checkbox"/>	<input type="checkbox"/>	<input type="checkbox"/> <input type="checkbox"/>	117.00#	1713
	TFME7248	<input type="checkbox"/> <input type="checkbox"/> <input type="checkbox"/> <input type="checkbox"/>	<input type="checkbox"/>	<input type="checkbox"/> <input type="checkbox"/>	125.00#	1741
	TFME7848	<input type="checkbox"/> <input type="checkbox"/> <input type="checkbox"/> <input type="checkbox"/>	<input type="checkbox"/>	<input type="checkbox"/> <input type="checkbox"/>	133.00#	1875
	TFME8448	<input type="checkbox"/> <input type="checkbox"/> <input type="checkbox"/> <input type="checkbox"/>	<input type="checkbox"/>	<input type="checkbox"/> <input type="checkbox"/>	141.00#	1904
	TFME9048	<input type="checkbox"/> <input type="checkbox"/> <input type="checkbox"/> <input type="checkbox"/>	<input type="checkbox"/>	<input type="checkbox"/> <input type="checkbox"/>	149.00#	2039
	TFME9648	<input type="checkbox"/> <input type="checkbox"/> <input type="checkbox"/> <input type="checkbox"/>	<input type="checkbox"/>	<input type="checkbox"/> <input type="checkbox"/>	157.00#	2067
<p>Monolithic Flex Screen with Magnetic Dry-Erasable Steel Core - 54" H</p> <ul style="list-style-type: none"> Flex screen assembly includes aluminum powder-coated frame, core material, all trim, and feet Steel core is dry-erasable and magnetic Specify adjustable glide feet, or non-adjustable flat/bridge feet Non-powered with elevated base; no wire management Fully assembled; includes all trim Slotting under upper trim accepts screen-hung accessories 	TFME4254	<input type="checkbox"/> <input type="checkbox"/> <input type="checkbox"/> <input type="checkbox"/>	<input type="checkbox"/>	<input type="checkbox"/> <input type="checkbox"/>	92.00#	\$ 1401
	TFME4854	<input type="checkbox"/> <input type="checkbox"/> <input type="checkbox"/> <input type="checkbox"/>	<input type="checkbox"/>	<input type="checkbox"/> <input type="checkbox"/>	101.00#	1429
	TFME5454	<input type="checkbox"/> <input type="checkbox"/> <input type="checkbox"/> <input type="checkbox"/>	<input type="checkbox"/>	<input type="checkbox"/> <input type="checkbox"/>	110.00#	1552
	TFME6054	<input type="checkbox"/> <input type="checkbox"/> <input type="checkbox"/> <input type="checkbox"/>	<input type="checkbox"/>	<input type="checkbox"/> <input type="checkbox"/>	119.00#	1586
	TFME6654	<input type="checkbox"/> <input type="checkbox"/> <input type="checkbox"/> <input type="checkbox"/>	<input type="checkbox"/>	<input type="checkbox"/> <input type="checkbox"/>	128.00#	1724
	TFME7254	<input type="checkbox"/> <input type="checkbox"/> <input type="checkbox"/> <input type="checkbox"/>	<input type="checkbox"/>	<input type="checkbox"/> <input type="checkbox"/>	137.00#	1756
	TFME7854	<input type="checkbox"/> <input type="checkbox"/> <input type="checkbox"/> <input type="checkbox"/>	<input type="checkbox"/>	<input type="checkbox"/> <input type="checkbox"/>	146.00#	1894
	TFME8454	<input type="checkbox"/> <input type="checkbox"/> <input type="checkbox"/> <input type="checkbox"/>	<input type="checkbox"/>	<input type="checkbox"/> <input type="checkbox"/>	155.00#	1937
	TFME9054	<input type="checkbox"/> <input type="checkbox"/> <input type="checkbox"/> <input type="checkbox"/>	<input type="checkbox"/>	<input type="checkbox"/> <input type="checkbox"/>	164.00#	2074
	TFME9654	<input type="checkbox"/> <input type="checkbox"/> <input type="checkbox"/> <input type="checkbox"/>	<input type="checkbox"/>	<input type="checkbox"/> <input type="checkbox"/>	173.00#	2105

A **B** **C** **D**

HOW TO ORDER

- Indicate the following information on order form:
- Quantity of each item.
 - Model number, including options. See "How To Build a Model Number".
 - Any special service required.

Note:

- The indicates that a choice is required.
- The absence of the indicates that no choice is required.
- Alpha-numeric characters in place of indicate that no other alternatives are available.

HOW TO BUILD A MODEL NUMBER

- A** Select basic model.
- B** Select foot option.
FADJ - Adjustable
FFLB - Flat/Bridge
- C** Select top cap style.
F - Flat aluminum top cap (standard)
N - No top cap (specify for use with toppers)
- D** Select frame/trim color.
 Refer to the **Product Color Options** page in this price list.

SPECIAL SERVICES

Special Carton Marking

With specially marked information N/C

Shipping

Ships assembled, FOB Manitowoc, WI 54220, freight prepaid. Freight class 70.

Specifications and prices are subject to change without prior notice.

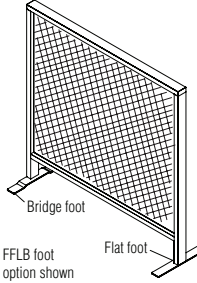

MODEL	MODEL NUMBER					Approx. Packaged Weight	Delivered Pricing
	Basic Model	Foot Option	Top Cap Style	Frame/Trim Color	Polyester Felt Color		
 <p>Monolithic Flex Screen with Polyester Felt Core - 42" H</p> <ul style="list-style-type: none"> Flex screen assembly includes aluminum powder-coated frame, core material, all trim, and feet Pinnable felt core is non-magnetic Specify adjustable glide feet or non-adjustable flat/bridge feet Non-powered with elevated base; no wire management Fully assembled; includes all trim Slotting under upper trim accepts screen-hung accessories 	TFMZ4242	<input type="checkbox"/>	<input type="checkbox"/>	<input type="checkbox"/>	<input type="checkbox"/>	54.00#	\$ 1354
	TFMZ4842	<input type="checkbox"/>	<input type="checkbox"/>	<input type="checkbox"/>	<input type="checkbox"/>	57.00#	1374
	TFMZ5442	<input type="checkbox"/>	<input type="checkbox"/>	<input type="checkbox"/>	<input type="checkbox"/>	61.00#	1399
	TFMZ6042	<input type="checkbox"/>	<input type="checkbox"/>	<input type="checkbox"/>	<input type="checkbox"/>	64.00#	1820
	TFMZ6642	<input type="checkbox"/>	<input type="checkbox"/>	<input type="checkbox"/>	<input type="checkbox"/>	67.00#	1847
	TFMZ7242	<input type="checkbox"/>	<input type="checkbox"/>	<input type="checkbox"/>	<input type="checkbox"/>	71.00#	1873
	TFMZ7842	<input type="checkbox"/>	<input type="checkbox"/>	<input type="checkbox"/>	<input type="checkbox"/>	75.00#	1899
	TFMZ8442	<input type="checkbox"/>	<input type="checkbox"/>	<input type="checkbox"/>	<input type="checkbox"/>	78.00#	1899
	TFMZ9042	<input type="checkbox"/>	<input type="checkbox"/>	<input type="checkbox"/>	<input type="checkbox"/>	82.00#	1945
	TFMZ9642	<input type="checkbox"/>	<input type="checkbox"/>	<input type="checkbox"/>	<input type="checkbox"/>	85.00#	1968
<p>Monolithic Flex Screen with Polyester Felt Core - 48" H</p> <ul style="list-style-type: none"> Flex screen assembly includes aluminum powder-coated frame, core material, all trim, and feet Pinnable felt core is non-magnetic Specify adjustable glide feet or non-adjustable flat/bridge feet Non-powered with elevated base; no wire management Fully assembled; includes all trim Slotting under upper trim accepts screen-hung accessories 	TFMZ4248	<input type="checkbox"/>	<input type="checkbox"/>	<input type="checkbox"/>	<input type="checkbox"/>	57.00#	\$ 1361
	TFMZ4848	<input type="checkbox"/>	<input type="checkbox"/>	<input type="checkbox"/>	<input type="checkbox"/>	61.00#	1385
	TFMZ5448	<input type="checkbox"/>	<input type="checkbox"/>	<input type="checkbox"/>	<input type="checkbox"/>	65.00#	1412
	TFMZ6048	<input type="checkbox"/>	<input type="checkbox"/>	<input type="checkbox"/>	<input type="checkbox"/>	69.00#	1841
	TFMZ6648	<input type="checkbox"/>	<input type="checkbox"/>	<input type="checkbox"/>	<input type="checkbox"/>	73.00#	1866
	TFMZ7248	<input type="checkbox"/>	<input type="checkbox"/>	<input type="checkbox"/>	<input type="checkbox"/>	77.00#	1893
	TFMZ7848	<input type="checkbox"/>	<input type="checkbox"/>	<input type="checkbox"/>	<input type="checkbox"/>	81.00#	1920
	TFMZ8448	<input type="checkbox"/>	<input type="checkbox"/>	<input type="checkbox"/>	<input type="checkbox"/>	85.00#	1945
	TFMZ9048	<input type="checkbox"/>	<input type="checkbox"/>	<input type="checkbox"/>	<input type="checkbox"/>	89.00#	1972
	TFMZ9648	<input type="checkbox"/>	<input type="checkbox"/>	<input type="checkbox"/>	<input type="checkbox"/>	93.00#	1998
<p>Monolithic Flex Screen with Polyester Felt Core - 54" H</p> <ul style="list-style-type: none"> Flex screen assembly includes aluminum powder-coated frame, core material, all trim, and feet Pinnable felt core is non-magnetic Specify adjustable glide feet or non-adjustable flat/bridge feet Non-powered with elevated base; no wire management Fully assembled; includes all trim Slotting under upper trim accepts screen-hung accessories 	TFMZ4254	<input type="checkbox"/>	<input type="checkbox"/>	<input type="checkbox"/>	<input type="checkbox"/>	61.00#	\$ 1367
	TFMZ4854	<input type="checkbox"/>	<input type="checkbox"/>	<input type="checkbox"/>	<input type="checkbox"/>	65.00#	1399
	TFMZ5454	<input type="checkbox"/>	<input type="checkbox"/>	<input type="checkbox"/>	<input type="checkbox"/>	70.00#	1429
	TFMZ6054	<input type="checkbox"/>	<input type="checkbox"/>	<input type="checkbox"/>	<input type="checkbox"/>	74.00#	1861
	TFMZ6654	<input type="checkbox"/>	<input type="checkbox"/>	<input type="checkbox"/>	<input type="checkbox"/>	79.00#	1893
	TFMZ7254	<input type="checkbox"/>	<input type="checkbox"/>	<input type="checkbox"/>	<input type="checkbox"/>	83.00#	1923
	TFMZ7854	<input type="checkbox"/>	<input type="checkbox"/>	<input type="checkbox"/>	<input type="checkbox"/>	88.00#	1954
	TFMZ8454	<input type="checkbox"/>	<input type="checkbox"/>	<input type="checkbox"/>	<input type="checkbox"/>	92.00#	1985
	TFMZ9054	<input type="checkbox"/>	<input type="checkbox"/>	<input type="checkbox"/>	<input type="checkbox"/>	97.00#	2013
	TFMZ9654	<input type="checkbox"/>	<input type="checkbox"/>	<input type="checkbox"/>	<input type="checkbox"/>	101.00#	2050

A **B** **C** **D** **E**

HOW TO ORDER

- Indicate the following information on order form:
- Quantity of each item.
 - Model number, including options. See "How To Build a Model Number".
 - Any special service required.

Note:

- The indicates that a choice is required.
- The absence of the indicates that no choice is required.
- Alpha-numeric characters in place of indicate that no other alternatives are available.

HOW TO BUILD A MODEL NUMBER

- A** Select basic model.
- B** Select foot option.

FADJ	- Adjustable
FFLB	- Flat/Bridge
- C** Select top cap style.

F	- Flat aluminum top cap (standard)
N	- No top cap (specify for use with toppers)
- D** Select frame/trim color.
Refer to the **Product Color Options** page in this price list.
- E** Select polyester felt color.
Refer to the **Product Color Options** page in this price list.

SPECIAL SERVICES

Special Carton Marking

With specially marked information N/C

Shipping

Ships assembled, FOB Manitowoc, WI 54220, freight prepaid. Freight class 70.

Specifications and prices are subject to change without prior notice.

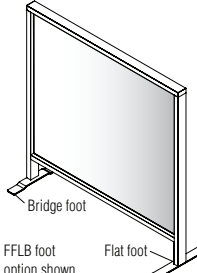

MODEL	MODEL NUMBER					Approx. Packaged Weight	Delivered Pricing
	Basic Model	Foot Option	Top Cap Style	Frame/Trim Color	Acrylic Color		
 <p>Monolithic Flex Screen with Acrylic Core - 42" H</p> <ul style="list-style-type: none"> Flex screen assembly includes aluminum powder-coated frame, core material, all trim, and feet Acrylic core is non-magnetic Specify adjustable glide feet or non-adjustable flat/bridge feet Non-powered with elevated base; no wire management Fully assembled; includes all trim Slotting under upper trim accepts screen-hung accessories 	TFMA4242	<input type="checkbox"/>	<input type="checkbox"/>	<input type="checkbox"/>	<input type="checkbox"/>	78.00#	\$ 2408
	TFMA4842	<input type="checkbox"/>	<input type="checkbox"/>	<input type="checkbox"/>	<input type="checkbox"/>	85.00#	2468
	TFMA5442	<input type="checkbox"/>	<input type="checkbox"/>	<input type="checkbox"/>	<input type="checkbox"/>	92.00#	2496
	TFMA6042	<input type="checkbox"/>	<input type="checkbox"/>	<input type="checkbox"/>	<input type="checkbox"/>	99.00#	2523
	TFMA6642	<input type="checkbox"/>	<input type="checkbox"/>	<input type="checkbox"/>	<input type="checkbox"/>	106.00#	2551
	TFMA7242	<input type="checkbox"/>	<input type="checkbox"/>	<input type="checkbox"/>	<input type="checkbox"/>	113.00#	2580
	TFMA7842	<input type="checkbox"/>	<input type="checkbox"/>	<input type="checkbox"/>	<input type="checkbox"/>	120.00#	2608
	TFMA8442	<input type="checkbox"/>	<input type="checkbox"/>	<input type="checkbox"/>	<input type="checkbox"/>	127.00#	4127
	TFMA9042	<input type="checkbox"/>	<input type="checkbox"/>	<input type="checkbox"/>	<input type="checkbox"/>	134.00#	4155
	TFMA9642	<input type="checkbox"/>	<input type="checkbox"/>	<input type="checkbox"/>	<input type="checkbox"/>	141.00#	4183
<p>Monolithic Flex Screen with Acrylic Core - 48" H</p> <ul style="list-style-type: none"> Flex screen assembly includes aluminum powder-coated frame, core material, all trim, and feet Acrylic core is non-magnetic Specify adjustable glide feet or non-adjustable flat/bridge feet Non-powered with elevated base; no wire management Fully assembled; includes all trim Slotting under upper trim accepts screen-hung accessories 	TFMA4248	<input type="checkbox"/>	<input type="checkbox"/>	<input type="checkbox"/>	<input type="checkbox"/>	85.00#	\$ 2443
	TFMA4848	<input type="checkbox"/>	<input type="checkbox"/>	<input type="checkbox"/>	<input type="checkbox"/>	93.00#	2502
	TFMA5448	<input type="checkbox"/>	<input type="checkbox"/>	<input type="checkbox"/>	<input type="checkbox"/>	101.00#	2532
	TFMA6048	<input type="checkbox"/>	<input type="checkbox"/>	<input type="checkbox"/>	<input type="checkbox"/>	109.00#	2559
	TFMA6648	<input type="checkbox"/>	<input type="checkbox"/>	<input type="checkbox"/>	<input type="checkbox"/>	117.00#	2587
	TFMA7248	<input type="checkbox"/>	<input type="checkbox"/>	<input type="checkbox"/>	<input type="checkbox"/>	125.00#	2615
	TFMA7848	<input type="checkbox"/>	<input type="checkbox"/>	<input type="checkbox"/>	<input type="checkbox"/>	133.00#	2643
	TFMA8448	<input type="checkbox"/>	<input type="checkbox"/>	<input type="checkbox"/>	<input type="checkbox"/>	141.00#	4161
	TFMA9048	<input type="checkbox"/>	<input type="checkbox"/>	<input type="checkbox"/>	<input type="checkbox"/>	149.00#	4189
	TFMA9648	<input type="checkbox"/>	<input type="checkbox"/>	<input type="checkbox"/>	<input type="checkbox"/>	157.00#	4216
<p>Monolithic Flex Screen with Acrylic Core - 54" H</p> <ul style="list-style-type: none"> Flex screen assembly includes aluminum powder-coated frame, core material, all trim, and feet Acrylic core is non-magnetic Specify adjustable glide feet or non-adjustable flat/bridge feet Non-powered with elevated base; no wire management Fully assembled; includes all trim Slotting under upper trim accepts screen-hung accessories 	TFMA4254	<input type="checkbox"/>	<input type="checkbox"/>	<input type="checkbox"/>	<input type="checkbox"/>	92.00#	\$ 2477
	TFMA4854	<input type="checkbox"/>	<input type="checkbox"/>	<input type="checkbox"/>	<input type="checkbox"/>	101.00#	2505
	TFMA5454	<input type="checkbox"/>	<input type="checkbox"/>	<input type="checkbox"/>	<input type="checkbox"/>	110.00#	2535
	TFMA6054	<input type="checkbox"/>	<input type="checkbox"/>	<input type="checkbox"/>	<input type="checkbox"/>	119.00#	2566
	TFMA6654	<input type="checkbox"/>	<input type="checkbox"/>	<input type="checkbox"/>	<input type="checkbox"/>	128.00#	2597
	TFMA7254	<input type="checkbox"/>	<input type="checkbox"/>	<input type="checkbox"/>	<input type="checkbox"/>	137.00#	2629
	TFMA7854	<input type="checkbox"/>	<input type="checkbox"/>	<input type="checkbox"/>	<input type="checkbox"/>	146.00#	2661
	TFMA8454	<input type="checkbox"/>	<input type="checkbox"/>	<input type="checkbox"/>	<input type="checkbox"/>	155.00#	4183
	TFMA9054	<input type="checkbox"/>	<input type="checkbox"/>	<input type="checkbox"/>	<input type="checkbox"/>	164.00#	4214
	TFMA9654	<input type="checkbox"/>	<input type="checkbox"/>	<input type="checkbox"/>	<input type="checkbox"/>	173.00#	4245

A **B** **C** **D** **E**

HOW TO ORDER

- Indicate the following information on order form:
- Quantity of each item.
 - Model number, including options. See "How To Build a Model Number".
 - Any special service required.

Note:

- The indicates that a choice is required.
- The absence of the indicates that no choice is required.
- Alpha-numeric characters in place of indicate that no other alternatives are available.

HOW TO BUILD A MODEL NUMBER

- A** Select basic model.
- B** Select foot option.

FADJ	- Adjustable
FFLB	- Flat/Bridge
- C** Select top cap style.

F	- Flat aluminum top cap (standard)
N	- No top cap (specify for use with toppers)
- D** Select frame/trim color.
Refer to the **Product Color Options** page in this price list.
- E** Select acrylic color.
Refer to the **Product Color Options** page in this price list.

SPECIAL SERVICES

Special Carton Marking

With specially marked information N/C

Shipping

Ships assembled, FOB Manitowoc, WI 54220, freight prepaid. Freight class 70.

Specifications and prices are subject to change without prior notice.

Tattoo™ Flex Screens

Monolithic Flex Screen with Thermally-Fused Laminate Core

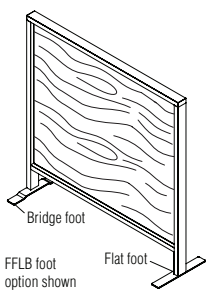

Tattoo™ Flex Screens
Monolithic Flex Screen with Thermally-Fused Laminate Core

MODEL	MODEL NUMBER					Approx. Packaged Weight	Delivered Pricing
	Basic Model	Foot Option	Top Cap Style	Frame/Trim Color	Laminate Color		
 <p>Monolithic Flex Screen with Thermally-Fused Laminate Core - 42" H</p> <ul style="list-style-type: none"> Flex screen assembly includes aluminum powder-coated frame, core material, all trim, and feet Thermally-fused laminate core is non-tackable, and non-magnetic Specify adjustable glide feet or non-adjustable flat/bridge feet Non-powered with elevated base; no wire management Fully assembled; includes all trim Slotting under upper trim accepts screen-hung accessories 	TFMM4242	<input type="checkbox"/> <input type="checkbox"/> <input type="checkbox"/> <input type="checkbox"/>	<input type="checkbox"/>	<input type="checkbox"/>	<input type="checkbox"/> <input type="checkbox"/>	78.00#	\$ 880
	TFMM4842	<input type="checkbox"/> <input type="checkbox"/> <input type="checkbox"/> <input type="checkbox"/>	<input type="checkbox"/>	<input type="checkbox"/>	<input type="checkbox"/> <input type="checkbox"/>	85.00#	949
	TFMM5442	<input type="checkbox"/> <input type="checkbox"/> <input type="checkbox"/> <input type="checkbox"/>	<input type="checkbox"/>	<input type="checkbox"/>	<input type="checkbox"/> <input type="checkbox"/>	92.00#	1055
	TFMM6042	<input type="checkbox"/> <input type="checkbox"/> <input type="checkbox"/> <input type="checkbox"/>	<input type="checkbox"/>	<input type="checkbox"/>	<input type="checkbox"/> <input type="checkbox"/>	99.00#	1078
	TFMM6642	<input type="checkbox"/> <input type="checkbox"/> <input type="checkbox"/> <input type="checkbox"/>	<input type="checkbox"/>	<input type="checkbox"/>	<input type="checkbox"/> <input type="checkbox"/>	106.00#	1104
	TFMM7242	<input type="checkbox"/> <input type="checkbox"/> <input type="checkbox"/> <input type="checkbox"/>	<input type="checkbox"/>	<input type="checkbox"/>	<input type="checkbox"/> <input type="checkbox"/>	113.00#	1128
	TFMM7842	<input type="checkbox"/> <input type="checkbox"/> <input type="checkbox"/> <input type="checkbox"/>	<input type="checkbox"/>	<input type="checkbox"/>	<input type="checkbox"/> <input type="checkbox"/>	120.00#	1152
	TFMM8442	<input type="checkbox"/> <input type="checkbox"/> <input type="checkbox"/> <input type="checkbox"/>	<input type="checkbox"/>	<input type="checkbox"/>	<input type="checkbox"/> <input type="checkbox"/>	127.00#	1174
	TFMM9042	<input type="checkbox"/> <input type="checkbox"/> <input type="checkbox"/> <input type="checkbox"/>	<input type="checkbox"/>	<input type="checkbox"/>	<input type="checkbox"/> <input type="checkbox"/>	134.00#	1200
	TFMM9642	<input type="checkbox"/> <input type="checkbox"/> <input type="checkbox"/> <input type="checkbox"/>	<input type="checkbox"/>	<input type="checkbox"/>	<input type="checkbox"/> <input type="checkbox"/>	141.00#	1223
<p>Monolithic Flex Screen with Thermally-Fused Laminate Core - 48" H</p> <ul style="list-style-type: none"> Flex screen assembly includes aluminum powder-coated frame, core material, all trim, and feet Thermally-fused laminate core is non-tackable, and non-magnetic Specify adjustable glide feet or non-adjustable flat/bridge feet Non-powered with elevated base; no wire management Fully assembled; includes all trim Slotting under upper trim accepts screen-hung accessories 	TFMM4248	<input type="checkbox"/> <input type="checkbox"/> <input type="checkbox"/> <input type="checkbox"/>	<input type="checkbox"/>	<input type="checkbox"/>	<input type="checkbox"/> <input type="checkbox"/>	85.00#	\$ 907
	TFMM4848	<input type="checkbox"/> <input type="checkbox"/> <input type="checkbox"/> <input type="checkbox"/>	<input type="checkbox"/>	<input type="checkbox"/>	<input type="checkbox"/> <input type="checkbox"/>	93.00#	977
	TFMM5448	<input type="checkbox"/> <input type="checkbox"/> <input type="checkbox"/> <input type="checkbox"/>	<input type="checkbox"/>	<input type="checkbox"/>	<input type="checkbox"/> <input type="checkbox"/>	101.00#	1083
	TFMM6048	<input type="checkbox"/> <input type="checkbox"/> <input type="checkbox"/> <input type="checkbox"/>	<input type="checkbox"/>	<input type="checkbox"/>	<input type="checkbox"/> <input type="checkbox"/>	109.00#	1106
	TFMM6648	<input type="checkbox"/> <input type="checkbox"/> <input type="checkbox"/> <input type="checkbox"/>	<input type="checkbox"/>	<input type="checkbox"/>	<input type="checkbox"/> <input type="checkbox"/>	117.00#	1130
	TFMM7248	<input type="checkbox"/> <input type="checkbox"/> <input type="checkbox"/> <input type="checkbox"/>	<input type="checkbox"/>	<input type="checkbox"/>	<input type="checkbox"/> <input type="checkbox"/>	125.00#	1155
	TFMM7848	<input type="checkbox"/> <input type="checkbox"/> <input type="checkbox"/> <input type="checkbox"/>	<input type="checkbox"/>	<input type="checkbox"/>	<input type="checkbox"/> <input type="checkbox"/>	133.00#	1179
	TFMM8448	<input type="checkbox"/> <input type="checkbox"/> <input type="checkbox"/> <input type="checkbox"/>	<input type="checkbox"/>	<input type="checkbox"/>	<input type="checkbox"/> <input type="checkbox"/>	141.00#	1202
	TFMM9048	<input type="checkbox"/> <input type="checkbox"/> <input type="checkbox"/> <input type="checkbox"/>	<input type="checkbox"/>	<input type="checkbox"/>	<input type="checkbox"/> <input type="checkbox"/>	149.00#	1226
	TFMM9648	<input type="checkbox"/> <input type="checkbox"/> <input type="checkbox"/> <input type="checkbox"/>	<input type="checkbox"/>	<input type="checkbox"/>	<input type="checkbox"/> <input type="checkbox"/>	157.00#	1250
<p>Monolithic Flex Screen with Thermally-Fused Laminate Core - 54" H</p> <ul style="list-style-type: none"> Flex screen assembly includes aluminum powder-coated frame, core material, all trim, and feet Thermally-fused laminate core is non-tackable, and non-magnetic Specify adjustable glide feet or non-adjustable flat/bridge feet Non-powered with elevated base; no wire management Fully assembled; includes all trim Slotting under upper trim accepts screen-hung accessories 	TFMM4254	<input type="checkbox"/> <input type="checkbox"/> <input type="checkbox"/> <input type="checkbox"/>	<input type="checkbox"/>	<input type="checkbox"/>	<input type="checkbox"/> <input type="checkbox"/>	92.00#	\$ 945
	TFMM4854	<input type="checkbox"/> <input type="checkbox"/> <input type="checkbox"/> <input type="checkbox"/>	<input type="checkbox"/>	<input type="checkbox"/>	<input type="checkbox"/> <input type="checkbox"/>	101.00#	991
	TFMM5454	<input type="checkbox"/> <input type="checkbox"/> <input type="checkbox"/> <input type="checkbox"/>	<input type="checkbox"/>	<input type="checkbox"/>	<input type="checkbox"/> <input type="checkbox"/>	110.00#	1097
	TFMM6054	<input type="checkbox"/> <input type="checkbox"/> <input type="checkbox"/> <input type="checkbox"/>	<input type="checkbox"/>	<input type="checkbox"/>	<input type="checkbox"/> <input type="checkbox"/>	119.00#	1127
	TFMM6654	<input type="checkbox"/> <input type="checkbox"/> <input type="checkbox"/> <input type="checkbox"/>	<input type="checkbox"/>	<input type="checkbox"/>	<input type="checkbox"/> <input type="checkbox"/>	128.00#	1155
	TFMM7254	<input type="checkbox"/> <input type="checkbox"/> <input type="checkbox"/> <input type="checkbox"/>	<input type="checkbox"/>	<input type="checkbox"/>	<input type="checkbox"/> <input type="checkbox"/>	137.00#	1184
	TFMM7854	<input type="checkbox"/> <input type="checkbox"/> <input type="checkbox"/> <input type="checkbox"/>	<input type="checkbox"/>	<input type="checkbox"/>	<input type="checkbox"/> <input type="checkbox"/>	146.00#	1211
	TFMM8454	<input type="checkbox"/> <input type="checkbox"/> <input type="checkbox"/> <input type="checkbox"/>	<input type="checkbox"/>	<input type="checkbox"/>	<input type="checkbox"/> <input type="checkbox"/>	155.00#	1240
	TFMM9054	<input type="checkbox"/> <input type="checkbox"/> <input type="checkbox"/> <input type="checkbox"/>	<input type="checkbox"/>	<input type="checkbox"/>	<input type="checkbox"/> <input type="checkbox"/>	164.00#	1267
	TFMM9654	<input type="checkbox"/> <input type="checkbox"/> <input type="checkbox"/> <input type="checkbox"/>	<input type="checkbox"/>	<input type="checkbox"/>	<input type="checkbox"/> <input type="checkbox"/>	173.00#	1292

A **B** **C** **D** **E**

HOW TO ORDER

- Indicate the following information on order form:
- Quantity of each item.
 - Model number, including options. See "How To Build a Model Number".
 - Any special service required.

Note:

- The indicates that a choice is required.
- The absence of the indicates that no choice is required.
- Alpha-numeric characters in place of indicate that no other alternatives are available.

HOW TO BUILD A MODEL NUMBER

- A** Select basic model.
- B** Select foot option.

FADJ	- Adjustable
FFLB	- Flat/Bridge
- C** Select top cap style.

F	- Flat aluminum top cap (standard)
N	- No top cap (specify for use with toppers)
- D** Select frame/trim color.
Refer to the **Product Color Options** page in this price list.
- E** Select laminate.
Refer to the **Product Color Options** page in this price list.

SPECIAL SERVICES

Special Carton Marking

With specially marked information N/C

Shipping

Ships assembled, FOB Manitowoc, WI 54220, freight prepaid. Freight class 70.

Specifications and prices are subject to change without prior notice.

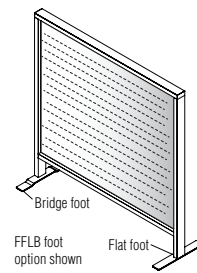

MODEL	MODEL NUMBER				Approx. Packaged Weight	Delivered Pricing
	Basic Model	Foot Option	Top Cap Style	Frame/Trim Color		
 <p>TFMP</p> <p>Monolithic Flex Screen with Fluted Polycarbonate Core - 42" H</p> <ul style="list-style-type: none"> Flex screen assembly includes aluminum powder-coated frame, core material, all trim, and feet Fluted polycarbonate core is non-tackable, and non-magnetic Specify adjustable glide feet or non-adjustable flat/bridge feet Non-powered with elevated base; no wire management Fully assembled; includes all trim Slotting under upper trim accepts screen-hung accessories Fluting runs horizontal 	TFMP4242	<input type="checkbox"/> <input type="checkbox"/> <input type="checkbox"/> <input type="checkbox"/>	<input type="checkbox"/>	<input type="checkbox"/> <input type="checkbox"/>	54.00#	\$ 1019
	TFMP4842	<input type="checkbox"/> <input type="checkbox"/> <input type="checkbox"/> <input type="checkbox"/>	<input type="checkbox"/>	<input type="checkbox"/> <input type="checkbox"/>	57.00#	1071
	TFMP5442	<input type="checkbox"/> <input type="checkbox"/> <input type="checkbox"/> <input type="checkbox"/>	<input type="checkbox"/>	<input type="checkbox"/> <input type="checkbox"/>	61.00#	1120
	TFMP6042	<input type="checkbox"/> <input type="checkbox"/> <input type="checkbox"/> <input type="checkbox"/>	<input type="checkbox"/>	<input type="checkbox"/> <input type="checkbox"/>	64.00#	1171
	TFMP6642	<input type="checkbox"/> <input type="checkbox"/> <input type="checkbox"/> <input type="checkbox"/>	<input type="checkbox"/>	<input type="checkbox"/> <input type="checkbox"/>	67.00#	1221
	TFMP7242	<input type="checkbox"/> <input type="checkbox"/> <input type="checkbox"/> <input type="checkbox"/>	<input type="checkbox"/>	<input type="checkbox"/> <input type="checkbox"/>	71.00#	1271
	TFMP7842	<input type="checkbox"/> <input type="checkbox"/> <input type="checkbox"/> <input type="checkbox"/>	<input type="checkbox"/>	<input type="checkbox"/> <input type="checkbox"/>	75.00#	1322
	TFMP8442	<input type="checkbox"/> <input type="checkbox"/> <input type="checkbox"/> <input type="checkbox"/>	<input type="checkbox"/>	<input type="checkbox"/> <input type="checkbox"/>	78.00#	1373
	TFMP9042	<input type="checkbox"/> <input type="checkbox"/> <input type="checkbox"/> <input type="checkbox"/>	<input type="checkbox"/>	<input type="checkbox"/> <input type="checkbox"/>	82.00#	1422
	TFMP9642	<input type="checkbox"/> <input type="checkbox"/> <input type="checkbox"/> <input type="checkbox"/>	<input type="checkbox"/>	<input type="checkbox"/> <input type="checkbox"/>	85.00#	1472
TFMP	TFMP4248	<input type="checkbox"/> <input type="checkbox"/> <input type="checkbox"/> <input type="checkbox"/>	<input type="checkbox"/>	<input type="checkbox"/> <input type="checkbox"/>	57.00#	\$ 1045
	TFMP4848	<input type="checkbox"/> <input type="checkbox"/> <input type="checkbox"/> <input type="checkbox"/>	<input type="checkbox"/>	<input type="checkbox"/> <input type="checkbox"/>	61.00#	1097
	TFMP5448	<input type="checkbox"/> <input type="checkbox"/> <input type="checkbox"/> <input type="checkbox"/>	<input type="checkbox"/>	<input type="checkbox"/> <input type="checkbox"/>	65.00#	1148
	TFMP6048	<input type="checkbox"/> <input type="checkbox"/> <input type="checkbox"/> <input type="checkbox"/>	<input type="checkbox"/>	<input type="checkbox"/> <input type="checkbox"/>	69.00#	1198
	TFMP6648	<input type="checkbox"/> <input type="checkbox"/> <input type="checkbox"/> <input type="checkbox"/>	<input type="checkbox"/>	<input type="checkbox"/> <input type="checkbox"/>	73.00#	1248
	TFMP7248	<input type="checkbox"/> <input type="checkbox"/> <input type="checkbox"/> <input type="checkbox"/>	<input type="checkbox"/>	<input type="checkbox"/> <input type="checkbox"/>	77.00#	1299
	TFMP7848	<input type="checkbox"/> <input type="checkbox"/> <input type="checkbox"/> <input type="checkbox"/>	<input type="checkbox"/>	<input type="checkbox"/> <input type="checkbox"/>	81.00#	1350
	TFMP8448	<input type="checkbox"/> <input type="checkbox"/> <input type="checkbox"/> <input type="checkbox"/>	<input type="checkbox"/>	<input type="checkbox"/> <input type="checkbox"/>	85.00#	1400
	TFMP9048	<input type="checkbox"/> <input type="checkbox"/> <input type="checkbox"/> <input type="checkbox"/>	<input type="checkbox"/>	<input type="checkbox"/> <input type="checkbox"/>	89.00#	1450
	TFMP9648	<input type="checkbox"/> <input type="checkbox"/> <input type="checkbox"/> <input type="checkbox"/>	<input type="checkbox"/>	<input type="checkbox"/> <input type="checkbox"/>	93.00#	1499
TFMP	TFMP4254	<input type="checkbox"/> <input type="checkbox"/> <input type="checkbox"/> <input type="checkbox"/>	<input type="checkbox"/>	<input type="checkbox"/> <input type="checkbox"/>	61.00#	\$ 1047
	TFMP4854	<input type="checkbox"/> <input type="checkbox"/> <input type="checkbox"/> <input type="checkbox"/>	<input type="checkbox"/>	<input type="checkbox"/> <input type="checkbox"/>	65.00#	1100
	TFMP5454	<input type="checkbox"/> <input type="checkbox"/> <input type="checkbox"/> <input type="checkbox"/>	<input type="checkbox"/>	<input type="checkbox"/> <input type="checkbox"/>	70.00#	1151
	TFMP6054	<input type="checkbox"/> <input type="checkbox"/> <input type="checkbox"/> <input type="checkbox"/>	<input type="checkbox"/>	<input type="checkbox"/> <input type="checkbox"/>	74.00#	1205
	TFMP6654	<input type="checkbox"/> <input type="checkbox"/> <input type="checkbox"/> <input type="checkbox"/>	<input type="checkbox"/>	<input type="checkbox"/> <input type="checkbox"/>	79.00#	1259
	TFMP7254	<input type="checkbox"/> <input type="checkbox"/> <input type="checkbox"/> <input type="checkbox"/>	<input type="checkbox"/>	<input type="checkbox"/> <input type="checkbox"/>	83.00#	1312
	TFMP7854	<input type="checkbox"/> <input type="checkbox"/> <input type="checkbox"/> <input type="checkbox"/>	<input type="checkbox"/>	<input type="checkbox"/> <input type="checkbox"/>	88.00#	1365
	TFMP8454	<input type="checkbox"/> <input type="checkbox"/> <input type="checkbox"/> <input type="checkbox"/>	<input type="checkbox"/>	<input type="checkbox"/> <input type="checkbox"/>	92.00#	1418
	TFMP9054	<input type="checkbox"/> <input type="checkbox"/> <input type="checkbox"/> <input type="checkbox"/>	<input type="checkbox"/>	<input type="checkbox"/> <input type="checkbox"/>	97.00#	1472
	TFMP9654	<input type="checkbox"/> <input type="checkbox"/> <input type="checkbox"/> <input type="checkbox"/>	<input type="checkbox"/>	<input type="checkbox"/> <input type="checkbox"/>	101.00#	1527

A **B** **C** **D**

HOW TO ORDER

- Indicate the following information on order form:
- Quantity of each item.
 - Model number, including options. See "How To Build a Model Number".
 - Any special service required.

Note: • The indicates that a choice is required.
 • The absence of the indicates that no choice is required.
 • Alpha-numeric characters in place of indicate that no other alternatives are available.

HOW TO BUILD A MODEL NUMBER

- A** Select basic model.
- B** Select foot option.
FADJ - Adjustable
FFLB - Flat/Bridge
- C** Select top cap style.
F - Flat aluminum top cap (standard)
N - No top cap (specify for use with toppers)
- D** Select frame/trim color.
 Refer to the **Product Color Options** page in this price list.

SPECIAL SERVICES

Special Carton Marking
 With specially marked information N/C

Shipping
 Ships assembled, FOB Manitowoc, WI 54220, freight prepaid. Freight class 70.

Specifications and prices are subject to change without prior notice.

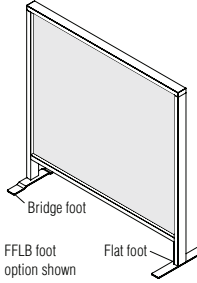

MODEL	MODEL NUMBER					Approx. Packaged Weight	Delivered Pricing Fabric Grade 1 & C.O.M.	Delivered Pricing Fabric Grade 2	Delivered Pricing Fabric Grade 3 & Pallas Vertical Fabric Grade PV	Delivered Pricing Pallas Vertical Fabric Grade PV1	Delivered Pricing Pallas Vertical Fabric Grade PV2
	Basic Model	Foot Option	Top Cap Style	Frame/Trim Color	Fabric Color						
 <p>Monolithic Flex Screen with Tackable Fabric Core - 42" H</p> <ul style="list-style-type: none"> Flex screen assembly includes aluminum powder-coated frame, core material, all trim, and feet Core features identical tackable fabric core on both sides, fabric pattern is railroaded Fabric cores are non-magnetic Specify adjustable glide feet or non-adjustable flat/bridge feet Non-powered with elevated base; no wire management Fully assembled; includes all trim Slotting under upper trim accepts screen-hung accessories 	TFMF4242	<input type="checkbox"/> <input type="checkbox"/> <input type="checkbox"/> <input type="checkbox"/>	<input type="checkbox"/>	<input type="checkbox"/> <input type="checkbox"/>	<input type="checkbox"/> <input type="checkbox"/> <input type="checkbox"/> <input type="checkbox"/> <input type="checkbox"/> <input type="checkbox"/>	54.00#	\$ 1137	\$ 1189	\$ 1238	\$ 1276	\$ 1365
	TFMF4842	<input type="checkbox"/> <input type="checkbox"/> <input type="checkbox"/> <input type="checkbox"/>	<input type="checkbox"/>	<input type="checkbox"/> <input type="checkbox"/>	<input type="checkbox"/> <input type="checkbox"/> <input type="checkbox"/> <input type="checkbox"/> <input type="checkbox"/> <input type="checkbox"/>	57.00#	1154	1205	1256	1294	1385
	TFMF5442	<input type="checkbox"/> <input type="checkbox"/> <input type="checkbox"/> <input type="checkbox"/>	<input type="checkbox"/>	<input type="checkbox"/> <input type="checkbox"/>	<input type="checkbox"/> <input type="checkbox"/> <input type="checkbox"/> <input type="checkbox"/> <input type="checkbox"/> <input type="checkbox"/>	61.00#	1185	1237	1290	1331	1422
	TFMF6042	<input type="checkbox"/> <input type="checkbox"/> <input type="checkbox"/> <input type="checkbox"/>	<input type="checkbox"/>	<input type="checkbox"/> <input type="checkbox"/>	<input type="checkbox"/> <input type="checkbox"/> <input type="checkbox"/> <input type="checkbox"/> <input type="checkbox"/> <input type="checkbox"/>	64.00#	1257	1314	1369	1409	1507
	TFMF6642	<input type="checkbox"/> <input type="checkbox"/> <input type="checkbox"/> <input type="checkbox"/>	<input type="checkbox"/>	<input type="checkbox"/> <input type="checkbox"/>	<input type="checkbox"/> <input type="checkbox"/> <input type="checkbox"/> <input type="checkbox"/> <input type="checkbox"/> <input type="checkbox"/>	67.00#	1319	1379	1440	1486	1593
	TFMF7242	<input type="checkbox"/> <input type="checkbox"/> <input type="checkbox"/> <input type="checkbox"/>	<input type="checkbox"/>	<input type="checkbox"/> <input type="checkbox"/>	<input type="checkbox"/> <input type="checkbox"/> <input type="checkbox"/> <input type="checkbox"/> <input type="checkbox"/> <input type="checkbox"/>	71.00#	1398	1461	1523	1572	1685
	TFMF7842	<input type="checkbox"/> <input type="checkbox"/> <input type="checkbox"/> <input type="checkbox"/>	<input type="checkbox"/>	<input type="checkbox"/> <input type="checkbox"/>	<input type="checkbox"/> <input type="checkbox"/> <input type="checkbox"/> <input type="checkbox"/> <input type="checkbox"/> <input type="checkbox"/>	75.00#	1422	1487	1551	1601	1716
	TFMF8442	<input type="checkbox"/> <input type="checkbox"/> <input type="checkbox"/> <input type="checkbox"/>	<input type="checkbox"/>	<input type="checkbox"/> <input type="checkbox"/>	<input type="checkbox"/> <input type="checkbox"/> <input type="checkbox"/> <input type="checkbox"/> <input type="checkbox"/> <input type="checkbox"/>	81.00#	1450	1516	1580	1631	1748
	TFMF9042	<input type="checkbox"/> <input type="checkbox"/> <input type="checkbox"/> <input type="checkbox"/>	<input type="checkbox"/>	<input type="checkbox"/> <input type="checkbox"/>	<input type="checkbox"/> <input type="checkbox"/> <input type="checkbox"/> <input type="checkbox"/> <input type="checkbox"/> <input type="checkbox"/>	82.00#	1481	1548	1616	1666	1784
	TFMF9642	<input type="checkbox"/> <input type="checkbox"/> <input type="checkbox"/> <input type="checkbox"/>	<input type="checkbox"/>	<input type="checkbox"/> <input type="checkbox"/>	<input type="checkbox"/> <input type="checkbox"/> <input type="checkbox"/> <input type="checkbox"/> <input type="checkbox"/> <input type="checkbox"/>	85.00#	1552	1624	1695	1746	1870
<p>Monolithic Flex Screen with Tackable Fabric Core - 48" H</p> <ul style="list-style-type: none"> Flex screen assembly includes aluminum powder-coated frame, core material, all trim, and feet Core features identical tackable fabric core on both sides, fabric pattern is railroaded Fabric cores are non-magnetic Specify adjustable glide feet or non-adjustable flat/bridge feet Non-powered with elevated base; no wire management Fully assembled; includes all trim Slotting under upper trim accepts screen-hung accessories 	TFMF4248	<input type="checkbox"/> <input type="checkbox"/> <input type="checkbox"/> <input type="checkbox"/>	<input type="checkbox"/>	<input type="checkbox"/> <input type="checkbox"/>	<input type="checkbox"/> <input type="checkbox"/> <input type="checkbox"/> <input type="checkbox"/> <input type="checkbox"/> <input type="checkbox"/>	57.00#	\$ 1179	\$ 1233	\$ 1284	\$ 1323	\$ 1416
	TFMF4848	<input type="checkbox"/> <input type="checkbox"/> <input type="checkbox"/> <input type="checkbox"/>	<input type="checkbox"/>	<input type="checkbox"/> <input type="checkbox"/>	<input type="checkbox"/> <input type="checkbox"/> <input type="checkbox"/> <input type="checkbox"/> <input type="checkbox"/> <input type="checkbox"/>	61.00#	1193	1247	1300	1341	1433
	TFMF5448	<input type="checkbox"/> <input type="checkbox"/> <input type="checkbox"/> <input type="checkbox"/>	<input type="checkbox"/>	<input type="checkbox"/> <input type="checkbox"/>	<input type="checkbox"/> <input type="checkbox"/> <input type="checkbox"/> <input type="checkbox"/> <input type="checkbox"/> <input type="checkbox"/>	65.00#	1225	1280	1334	1375	1470
	TFMF6048	<input type="checkbox"/> <input type="checkbox"/> <input type="checkbox"/> <input type="checkbox"/>	<input type="checkbox"/>	<input type="checkbox"/> <input type="checkbox"/>	<input type="checkbox"/> <input type="checkbox"/> <input type="checkbox"/> <input type="checkbox"/> <input type="checkbox"/> <input type="checkbox"/>	69.00#	1299	1355	1412	1455	1555
	TFMF6648	<input type="checkbox"/> <input type="checkbox"/> <input type="checkbox"/> <input type="checkbox"/>	<input type="checkbox"/>	<input type="checkbox"/> <input type="checkbox"/>	<input type="checkbox"/> <input type="checkbox"/> <input type="checkbox"/> <input type="checkbox"/> <input type="checkbox"/> <input type="checkbox"/>	73.00#	1358	1422	1485	1531	1642
	TFMF7248	<input type="checkbox"/> <input type="checkbox"/> <input type="checkbox"/> <input type="checkbox"/>	<input type="checkbox"/>	<input type="checkbox"/> <input type="checkbox"/>	<input type="checkbox"/> <input type="checkbox"/> <input type="checkbox"/> <input type="checkbox"/> <input type="checkbox"/> <input type="checkbox"/>	77.00#	1437	1503	1569	1617	1732
	TFMF7848	<input type="checkbox"/> <input type="checkbox"/> <input type="checkbox"/> <input type="checkbox"/>	<input type="checkbox"/>	<input type="checkbox"/> <input type="checkbox"/>	<input type="checkbox"/> <input type="checkbox"/> <input type="checkbox"/> <input type="checkbox"/> <input type="checkbox"/> <input type="checkbox"/>	81.00#	1463	1531	1598	1647	1763
	TFMF8448	<input type="checkbox"/> <input type="checkbox"/> <input type="checkbox"/> <input type="checkbox"/>	<input type="checkbox"/>	<input type="checkbox"/> <input type="checkbox"/>	<input type="checkbox"/> <input type="checkbox"/> <input type="checkbox"/> <input type="checkbox"/> <input type="checkbox"/> <input type="checkbox"/>	85.00#	1490	1559	1625	1676	1794
	TFMF9048	<input type="checkbox"/> <input type="checkbox"/> <input type="checkbox"/> <input type="checkbox"/>	<input type="checkbox"/>	<input type="checkbox"/> <input type="checkbox"/>	<input type="checkbox"/> <input type="checkbox"/> <input type="checkbox"/> <input type="checkbox"/> <input type="checkbox"/> <input type="checkbox"/>	89.00#	1520	1591	1659	1712	1833
	TFMF9648	<input type="checkbox"/> <input type="checkbox"/> <input type="checkbox"/> <input type="checkbox"/>	<input type="checkbox"/>	<input type="checkbox"/> <input type="checkbox"/>	<input type="checkbox"/> <input type="checkbox"/> <input type="checkbox"/> <input type="checkbox"/> <input type="checkbox"/> <input type="checkbox"/>	93.00#	1594	1666	1738	1792	1917

A **B** **C** **D** **E**

HOW TO ORDER

- Indicate the following information on order form:
- Quantity of each item.
 - Model number, including options. See "How To Build a Model Number".
 - Any special service required.

Note:

- The indicates that a choice is required.
- The absence of the indicates that no choice is required.
- Alpha-numeric characters in place of indicate that no other alternatives are available.

HOW TO BUILD A MODEL NUMBER

- A** Select basic model.
- B** Select foot option.

FADJ	- Adjustable
FFLB	- Flat/Bridge
- C** Select top cap style.

F	- Flat aluminum top cap (standard)
N	- No top cap (specify for use with toppers)
- D** Select frame/trim color.
Refer to the **Product Color Options** page in this price list.
- E** Select fabric color.
Refer to ki.com/fabrics

INFORMATION

COM YARDAGE REQUIREMENTS

Screen Width/Length	Fabric Required
42	2.556
48	2.889
54	3.222
60	3.556
66	3.889
72	4.222
78	4.556
84	4.889
90	5.222
96	5.556

SPECIAL SERVICES

Special Carton Marking

With specially marked information N/C

Shipping

Ships assembled, FOB Manitowoc, WI 54220, freight prepaid. Freight class 70.

Specifications and prices are subject to change without prior notice.



MODEL	MODEL NUMBER					Approx. Packaged Weight	Delivered Pricing Fabric Grade 1 & C.O.M.	Delivered Pricing Fabric Grade 2	Delivered Pricing Fabric Grade 3 & Pallas Vertical Fabric Grade PV	Delivered Pricing Pallas Vertical Fabric Grade PV1	Delivered Pricing Pallas Vertical Fabric Grade PV2
	Basic Model	Foot Option	Top Cap Style	Frame/Trim Color	Fabric Color						
TFMF Monolithic Flex Screen with Tackable Fabric Core - 54" H <ul style="list-style-type: none"> Flex screen assembly includes aluminum powder-coated frame, core material, all trim, and feet Core features identical tackable fabric core on both sides, fabric pattern is railroaded Fabric cores are non-magnetic Specify adjustable glide feet or non-adjustable flat/bridge feet Non-powered with elevated base; no wire management Fully assembled; includes all trim Slotting under upper trim accepts screen-hung accessories 	TFMF4254	<input type="checkbox"/> <input type="checkbox"/> <input type="checkbox"/> <input type="checkbox"/>	<input type="checkbox"/>	<input type="checkbox"/> <input type="checkbox"/>	<input type="checkbox"/> <input type="checkbox"/> <input type="checkbox"/> <input type="checkbox"/> <input type="checkbox"/> <input type="checkbox"/>	61.00#	\$ 1183	\$ 1235	\$ 1288	\$ 1326	\$ 1418
	TFMF4854	<input type="checkbox"/> <input type="checkbox"/> <input type="checkbox"/> <input type="checkbox"/>	<input type="checkbox"/>	<input type="checkbox"/> <input type="checkbox"/>	<input type="checkbox"/> <input type="checkbox"/> <input type="checkbox"/> <input type="checkbox"/> <input type="checkbox"/> <input type="checkbox"/>	65.00#	1196	1249	1303	1343	1436
	TFMF5454	<input type="checkbox"/> <input type="checkbox"/> <input type="checkbox"/> <input type="checkbox"/>	<input type="checkbox"/>	<input type="checkbox"/> <input type="checkbox"/>	<input type="checkbox"/> <input type="checkbox"/> <input type="checkbox"/> <input type="checkbox"/> <input type="checkbox"/> <input type="checkbox"/>	70.00#	1275	1331	1387	1430	1528
	TFMF6054	<input type="checkbox"/> <input type="checkbox"/> <input type="checkbox"/> <input type="checkbox"/>	<input type="checkbox"/>	<input type="checkbox"/> <input type="checkbox"/>	<input type="checkbox"/> <input type="checkbox"/> <input type="checkbox"/> <input type="checkbox"/> <input type="checkbox"/> <input type="checkbox"/>	74.00#	1304	1362	1419	1463	1563
	TFMF6654	<input type="checkbox"/> <input type="checkbox"/> <input type="checkbox"/> <input type="checkbox"/>	<input type="checkbox"/>	<input type="checkbox"/> <input type="checkbox"/>	<input type="checkbox"/> <input type="checkbox"/> <input type="checkbox"/> <input type="checkbox"/> <input type="checkbox"/> <input type="checkbox"/>	79.00#	1416	1481	1546	1594	1707
	TFMF7254	<input type="checkbox"/> <input type="checkbox"/> <input type="checkbox"/> <input type="checkbox"/>	<input type="checkbox"/>	<input type="checkbox"/> <input type="checkbox"/>	<input type="checkbox"/> <input type="checkbox"/> <input type="checkbox"/> <input type="checkbox"/> <input type="checkbox"/> <input type="checkbox"/>	83.00#	1451	1517	1584	1632	1749
	TFMF7854	<input type="checkbox"/> <input type="checkbox"/> <input type="checkbox"/> <input type="checkbox"/>	<input type="checkbox"/>	<input type="checkbox"/> <input type="checkbox"/>	<input type="checkbox"/> <input type="checkbox"/> <input type="checkbox"/> <input type="checkbox"/> <input type="checkbox"/> <input type="checkbox"/>	88.00#	1481	1548	1616	1666	1784
	TFMF8454	<input type="checkbox"/> <input type="checkbox"/> <input type="checkbox"/> <input type="checkbox"/>	<input type="checkbox"/>	<input type="checkbox"/> <input type="checkbox"/>	<input type="checkbox"/> <input type="checkbox"/> <input type="checkbox"/> <input type="checkbox"/> <input type="checkbox"/> <input type="checkbox"/>	92.00#	1558	1627	1698	1750	1873
	TFMF9054	<input type="checkbox"/> <input type="checkbox"/> <input type="checkbox"/> <input type="checkbox"/>	<input type="checkbox"/>	<input type="checkbox"/> <input type="checkbox"/>	<input type="checkbox"/> <input type="checkbox"/> <input type="checkbox"/> <input type="checkbox"/> <input type="checkbox"/> <input type="checkbox"/>	97.00#	1592	1663	1734	1789	1915
	TFMF9654	<input type="checkbox"/> <input type="checkbox"/> <input type="checkbox"/> <input type="checkbox"/>	<input type="checkbox"/>	<input type="checkbox"/> <input type="checkbox"/>	<input type="checkbox"/> <input type="checkbox"/> <input type="checkbox"/> <input type="checkbox"/> <input type="checkbox"/> <input type="checkbox"/>	101.00#	1667	1742	1816	1873	2004

A **B** **C** **D** **E**

HOW TO ORDER
Indicate the following information on order form:
1. Quantity of each item.
2. Model number, including options. See "How To Build a Model Number".
3. Any special service required.

Note: • The indicates that a choice is required.
• The absence of the indicates that no choice is required.
• Alpha-numeric characters in place of indicate that no other alternatives are available.

HOW TO BUILD A MODEL NUMBER

A Select basic model.

B Select foot option.
FADJ - Adjustable
FFLB - Flat/Bridge

C Select top cap style.
F - Flat aluminum top cap (standard)
N - No top cap (specify for use with toppers)

D Select frame/trim color.
Refer to the **Product Color Options** page in this price list.

E Select fabric color.
Refer to ki.com/fabrics

INFORMATION
COM YARDAGE REQUIREMENTS

Screen Width/Length	Fabric Required
42	2.556
48	2.889
54	3.222
60	3.556
66	3.889
72	4.222
78	4.556
84	4.889
90	5.222
96	5.556

SPECIAL SERVICES
Special Carton Marking
With specially marked information N/C

Shipping
Ships **assembled, FOB Manitowoc, WI 54220, freight prepaid.** Freight class 70.

Specifications and prices are subject to change without prior notice.

Tattoo™ Flex Screens

Segmented Flex Screen with Thermally-Fused Laminate Lower, Magnetic Dry-Erasable Steel Upper Core



Tattoo™ Flex Screens

Segmented Flex Screen with Thermally-Fused Laminate Lower, Magnetic Dry-Erasable Steel Upper Core

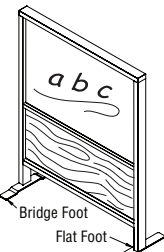
MODEL	MODEL NUMBER					Approx. Packaged Weight	Delivered Pricing
	Basic Model	Foot Option	Top Cap Style	Frame/Trim Color	Lower Laminate Color		
 <p>Segmented Flex Screen with Thermally-Fused Laminate Lower, Magnetic Dry-Erasable Steel Upper Core - 48" H</p> <ul style="list-style-type: none"> Flex screen assembly includes aluminum powder-coated frame, core material, all trim and feet Magnetic dry-erasable steel upper segment Thermally-fused laminate is non-tackable and non-magnetic Specify adjustable glide feet or non-adjustable flat/bridge feet Non-powered; no wire management Fully assembled; includes all trim Slotting under upper trim accepts screen-hung accessories Segmentation at 29" Elevated base does not accept power 	TFSME4248	<input type="checkbox"/>	<input type="checkbox"/>	<input type="checkbox"/>	<input type="checkbox"/>	78.00#	\$ 1292
	TFSME4848	<input type="checkbox"/>	<input type="checkbox"/>	<input type="checkbox"/>	<input type="checkbox"/>	85.00#	1430
	TFSME5448	<input type="checkbox"/>	<input type="checkbox"/>	<input type="checkbox"/>	<input type="checkbox"/>	92.00#	1645
	TFSME6048	<input type="checkbox"/>	<input type="checkbox"/>	<input type="checkbox"/>	<input type="checkbox"/>	99.00#	1717
	TFSME6648	<input type="checkbox"/>	<input type="checkbox"/>	<input type="checkbox"/>	<input type="checkbox"/>	106.00#	1841
	TFSME7248	<input type="checkbox"/>	<input type="checkbox"/>	<input type="checkbox"/>	<input type="checkbox"/>	113.00#	1913
	TFSME7848	<input type="checkbox"/>	<input type="checkbox"/>	<input type="checkbox"/>	<input type="checkbox"/>	120.00#	2034
	TFSME8448	<input type="checkbox"/>	<input type="checkbox"/>	<input type="checkbox"/>	<input type="checkbox"/>	127.00#	2056
	TFSME9048	<input type="checkbox"/>	<input type="checkbox"/>	<input type="checkbox"/>	<input type="checkbox"/>	134.00#	2076
	TFSME9648	<input type="checkbox"/>	<input type="checkbox"/>	<input type="checkbox"/>	<input type="checkbox"/>	141.00#	2099
<p>Segmented Flex Screen with Thermally-Fused Laminate Lower, Magnetic Dry-Erasable Steel Upper Core - 54" H</p> <ul style="list-style-type: none"> Flex screen assembly includes aluminum powder-coated frame, core material, all trim and feet Magnetic dry-erasable steel upper segment Thermally-fused laminate is non-tackable and non-magnetic Specify adjustable glide feet or non-adjustable flat/bridge feet Non-powered; no wire management Fully assembled; includes all trim Slotting under upper trim accepts screen-hung accessories Segmentation at 29" Elevated base does not accept power 	TFSME4254	<input type="checkbox"/>	<input type="checkbox"/>	<input type="checkbox"/>	<input type="checkbox"/>	85.00#	\$ 1333
	TFSME4854	<input type="checkbox"/>	<input type="checkbox"/>	<input type="checkbox"/>	<input type="checkbox"/>	93.00#	1522
	TFSME5454	<input type="checkbox"/>	<input type="checkbox"/>	<input type="checkbox"/>	<input type="checkbox"/>	101.00#	1689
	TFSME6054	<input type="checkbox"/>	<input type="checkbox"/>	<input type="checkbox"/>	<input type="checkbox"/>	109.00#	1762
	TFSME6654	<input type="checkbox"/>	<input type="checkbox"/>	<input type="checkbox"/>	<input type="checkbox"/>	117.00#	1886
	TFSME7254	<input type="checkbox"/>	<input type="checkbox"/>	<input type="checkbox"/>	<input type="checkbox"/>	125.00#	1958
	TFSME7854	<input type="checkbox"/>	<input type="checkbox"/>	<input type="checkbox"/>	<input type="checkbox"/>	133.00#	2079
	TFSME8454	<input type="checkbox"/>	<input type="checkbox"/>	<input type="checkbox"/>	<input type="checkbox"/>	141.00#	2104
	TFSME9054	<input type="checkbox"/>	<input type="checkbox"/>	<input type="checkbox"/>	<input type="checkbox"/>	149.00#	2125
	TFSME9654	<input type="checkbox"/>	<input type="checkbox"/>	<input type="checkbox"/>	<input type="checkbox"/>	157.00#	2146

A **B** **C** **D** **E**

HOW TO ORDER

- Indicate the following information on order form:
- Quantity of each item.
 - Model number, including options. See "How To Build a Model Number".
 - Any special service required.

Note: • The indicates that a choice is required.
 • The absence of the indicates that no choice is required.
 • Alpha-numeric characters in place of indicate that no other alternatives are available.

HOW TO BUILD A MODEL NUMBER

- A** Select basic model.
- B** Select foot option.

FADJ	- Adjustable
FFLB	- Flat/Bridge
- C** Select top cap style.

F	- Flat aluminum top cap (standard)
N	- No top cap (specify for use with toppers)
- D** Select frame/trim color. Refer to the **Product Color Options** page in this price list.
- E** Select lower laminate color. Refer to the **Product Color Options** page in this price list.

SPECIAL SERVICES

Special Carton Marking
 With specially marked information N/C

Shipping
 Ships assembled, FOB Manitowoc, WI 54220, freight prepaid. Freight class 70.

Specifications and prices are subject to change without prior notice.

Tattoo™ Flex Screens

Segmented Flex Screen with Thermally-Fused Laminate Lower and Upper Core



Tattoo™ Flex Screens

Segmented Flex Screen with Thermally-Fused Laminate Lower and Upper Core

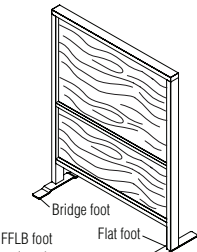
MODEL	MODEL NUMBER						Approx. Packaged Weight	Delivered Pricing
	Basic Model	Foot Option	Top Cap Style	Frame/Trim Color	Lower Laminate Color	Upper Laminate Color		
 <p>FFLB foot option shown</p> <p>TFSMM</p> <p>Segmented Flex Screen with Thermally-Fused Laminate Lower and Upper Core - 48" H</p> <ul style="list-style-type: none"> Flex screen assembly includes aluminum powder-coated frame, core material, all trim and feet Thermally-fused laminate is non-tackable and non-magnetic Specify adjustable glide feet or non-adjustable flat/bridge feet Non-powered; no wire management Fully assembled; includes all trim Slotting under upper trim accepts screen-hung accessories Segmentation at 29" Elevated base does not accept power 	TFSMM4248	<input type="checkbox"/>	<input type="checkbox"/>	<input type="checkbox"/>	<input type="checkbox"/>	<input type="checkbox"/>	78.00#	\$ 1345
	TFSMM4848	<input type="checkbox"/>	<input type="checkbox"/>	<input type="checkbox"/>	<input type="checkbox"/>	<input type="checkbox"/>	85.00#	1350
	TFSMM5448	<input type="checkbox"/>	<input type="checkbox"/>	<input type="checkbox"/>	<input type="checkbox"/>	<input type="checkbox"/>	92.00#	1493
	TFSMM6048	<input type="checkbox"/>	<input type="checkbox"/>	<input type="checkbox"/>	<input type="checkbox"/>	<input type="checkbox"/>	99.00#	1565
	TFSMM6648	<input type="checkbox"/>	<input type="checkbox"/>	<input type="checkbox"/>	<input type="checkbox"/>	<input type="checkbox"/>	106.00#	1637
	TFSMM7248	<input type="checkbox"/>	<input type="checkbox"/>	<input type="checkbox"/>	<input type="checkbox"/>	<input type="checkbox"/>	113.00#	1710
	TFSMM7848	<input type="checkbox"/>	<input type="checkbox"/>	<input type="checkbox"/>	<input type="checkbox"/>	<input type="checkbox"/>	120.00#	1731
	TFSMM8448	<input type="checkbox"/>	<input type="checkbox"/>	<input type="checkbox"/>	<input type="checkbox"/>	<input type="checkbox"/>	127.00#	1752
	TFSMM9048	<input type="checkbox"/>	<input type="checkbox"/>	<input type="checkbox"/>	<input type="checkbox"/>	<input type="checkbox"/>	134.00#	1775
	TFSMM9648	<input type="checkbox"/>	<input type="checkbox"/>	<input type="checkbox"/>	<input type="checkbox"/>	<input type="checkbox"/>	141.00#	1794
TFSMM	TFSMM4254	<input type="checkbox"/>	<input type="checkbox"/>	<input type="checkbox"/>	<input type="checkbox"/>	<input type="checkbox"/>	85.00#	\$ 1381
	TFSMM4854	<input type="checkbox"/>	<input type="checkbox"/>	<input type="checkbox"/>	<input type="checkbox"/>	<input type="checkbox"/>	93.00#	1406
	TFSMM5454	<input type="checkbox"/>	<input type="checkbox"/>	<input type="checkbox"/>	<input type="checkbox"/>	<input type="checkbox"/>	101.00#	1565
	TFSMM6054	<input type="checkbox"/>	<input type="checkbox"/>	<input type="checkbox"/>	<input type="checkbox"/>	<input type="checkbox"/>	109.00#	1637
	TFSMM6654	<input type="checkbox"/>	<input type="checkbox"/>	<input type="checkbox"/>	<input type="checkbox"/>	<input type="checkbox"/>	117.00#	1710
	TFSMM7254	<input type="checkbox"/>	<input type="checkbox"/>	<input type="checkbox"/>	<input type="checkbox"/>	<input type="checkbox"/>	125.00#	1784
	TFSMM7854	<input type="checkbox"/>	<input type="checkbox"/>	<input type="checkbox"/>	<input type="checkbox"/>	<input type="checkbox"/>	133.00#	1806
	TFSMM8454	<input type="checkbox"/>	<input type="checkbox"/>	<input type="checkbox"/>	<input type="checkbox"/>	<input type="checkbox"/>	141.00#	1829
	TFSMM9054	<input type="checkbox"/>	<input type="checkbox"/>	<input type="checkbox"/>	<input type="checkbox"/>	<input type="checkbox"/>	149.00#	1849
	TFSMM9654	<input type="checkbox"/>	<input type="checkbox"/>	<input type="checkbox"/>	<input type="checkbox"/>	<input type="checkbox"/>	157.00#	1872

A **B** **C** **D** **E** **F**

HOW TO ORDER

- Indicate the following information on order form:
- Quantity of each item.
 - Model number, including options. See "How To Build a Model Number".
 - Any special service required.

Note:

- The indicates that a choice is required.
- The absence of the indicates that no choice is required.
- Alpha-numeric characters in place of indicate that no other alternatives are available.

HOW TO BUILD A MODEL NUMBER

- A** Select basic model.
- B** Select foot option.

FADJ	- Adjustable
FFLB	- Flat/Bridge
- C** Select top cap style.

F	- Flat aluminum top cap (standard)
N	- No top cap (specify for use with toppers)
- D** Select frame/trim color. Refer to the **Product Color Options** page in this price list.
- E** Select lower laminate color. Refer to the **Product Color Options** page in this price list.
- F** Select upper laminate color. Refer to the **Product Color Options** page in this price list.

SPECIAL SERVICES

Special Carton Marking

With specially marked information N/C

Shipping

Ships **assembled, FOB Manitowoc, WI 54220, freight prepaid**. Freight class 70.

Specifications and prices are subject to change without prior notice.

Tattoo™ Flex Screens

Segmented Flex Screen with Thermally-Fused Laminate Lower, Polyester Felt Upper Core



Tattoo™ Flex Screens

Segmented Flex Screen with Thermally-Fused Laminate Lower, Polyester Felt Upper Core

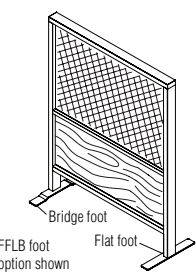
MODEL	MODEL NUMBER						Approx. Packaged Weight	Delivered Pricing
	Basic Model	Foot Option	Top Cap Style	Frame/Trim Color	Lower Laminate Color	Upper Polyester Felt Color		
 <p>Segmented Flex Screen with Thermally-Fused Laminate Lower, Polyester Felt Upper Core - 48" H</p> <ul style="list-style-type: none"> Flex screen assembly includes aluminum powder-coated frame, core material, all trim and feet Polyester felt upper segment is pinnable and non-magnetic Thermally-fused laminate is non-tackable and non-magnetic Specify adjustable glide feet or non-adjustable flat/bridge feet Non-powered; no wire management Fully assembled; includes all trim Slotting under upper trim accepts screen-hung accessories Segmentation at 29" Elevated base does not accept power 	TFSMZ4248	<input type="checkbox"/>	<input type="checkbox"/>	<input type="checkbox"/>	<input type="checkbox"/>	<input type="checkbox"/>	72.00#	\$ 1351
	TFSMZ4848	<input type="checkbox"/>	<input type="checkbox"/>	<input type="checkbox"/>	<input type="checkbox"/>	<input type="checkbox"/>	78.00#	1431
	TFSMZ5448	<input type="checkbox"/>	<input type="checkbox"/>	<input type="checkbox"/>	<input type="checkbox"/>	<input type="checkbox"/>	84.00#	1624
	TFSMZ6048	<input type="checkbox"/>	<input type="checkbox"/>	<input type="checkbox"/>	<input type="checkbox"/>	<input type="checkbox"/>	90.00#	1904
	TFSMZ6648	<input type="checkbox"/>	<input type="checkbox"/>	<input type="checkbox"/>	<input type="checkbox"/>	<input type="checkbox"/>	96.00#	1976
	TFSMZ7248	<input type="checkbox"/>	<input type="checkbox"/>	<input type="checkbox"/>	<input type="checkbox"/>	<input type="checkbox"/>	102.00#	2050
	TFSMZ7848	<input type="checkbox"/>	<input type="checkbox"/>	<input type="checkbox"/>	<input type="checkbox"/>	<input type="checkbox"/>	108.00#	2072
	TFSMZ8448	<input type="checkbox"/>	<input type="checkbox"/>	<input type="checkbox"/>	<input type="checkbox"/>	<input type="checkbox"/>	114.00#	2090
	TFSMZ9048	<input type="checkbox"/>	<input type="checkbox"/>	<input type="checkbox"/>	<input type="checkbox"/>	<input type="checkbox"/>	120.00#	2113
	TFSMZ9648	<input type="checkbox"/>	<input type="checkbox"/>	<input type="checkbox"/>	<input type="checkbox"/>	<input type="checkbox"/>	126.00#	2133
<p>Segmented Flex Screen with Thermally-Fused Laminate Lower, Polyester Felt Upper Core - 54" H</p> <ul style="list-style-type: none"> Flex screen assembly includes aluminum powder-coated frame, core material, all trim and feet Polyester felt upper segment is pinnable and non-magnetic Thermally-fused laminate is non-tackable and non-magnetic Specify adjustable glide feet or non-adjustable flat/bridge feet Non-powered; no wire management Fully assembled; includes all trim Slotting under upper trim accepts screen-hung accessories Segmentation at 29" Elevated base does not accept power 	TFSMZ4254	<input type="checkbox"/>	<input type="checkbox"/>	<input type="checkbox"/>	<input type="checkbox"/>	<input type="checkbox"/>	78.00#	\$ 1465
	TFSMZ4854	<input type="checkbox"/>	<input type="checkbox"/>	<input type="checkbox"/>	<input type="checkbox"/>	<input type="checkbox"/>	84.00#	1551
	TFSMZ5454	<input type="checkbox"/>	<input type="checkbox"/>	<input type="checkbox"/>	<input type="checkbox"/>	<input type="checkbox"/>	91.00#	1667
	TFSMZ6054	<input type="checkbox"/>	<input type="checkbox"/>	<input type="checkbox"/>	<input type="checkbox"/>	<input type="checkbox"/>	98.00#	1947
	TFSMZ6654	<input type="checkbox"/>	<input type="checkbox"/>	<input type="checkbox"/>	<input type="checkbox"/>	<input type="checkbox"/>	100.00#	2022
	TFSMZ7254	<input type="checkbox"/>	<input type="checkbox"/>	<input type="checkbox"/>	<input type="checkbox"/>	<input type="checkbox"/>	111.00#	2094
	TFSMZ7854	<input type="checkbox"/>	<input type="checkbox"/>	<input type="checkbox"/>	<input type="checkbox"/>	<input type="checkbox"/>	118.00#	2117
	TFSMZ8454	<input type="checkbox"/>	<input type="checkbox"/>	<input type="checkbox"/>	<input type="checkbox"/>	<input type="checkbox"/>	125.00#	2138
	TFSMZ9054	<input type="checkbox"/>	<input type="checkbox"/>	<input type="checkbox"/>	<input type="checkbox"/>	<input type="checkbox"/>	132.00#	2160
	TFSMZ9654	<input type="checkbox"/>	<input type="checkbox"/>	<input type="checkbox"/>	<input type="checkbox"/>	<input type="checkbox"/>	138.00#	2182

A **B** **C** **D** **E** **F**

HOW TO ORDER

- Indicate the following information on order form:
- Quantity of each item.
 - Model number, including options. See "How To Build a Model Number".
 - Any special service required.

Note: • The indicates that a choice is required.
 • The absence of the indicates that no choice is required.
 • Alpha-numeric characters in place of indicate that no other alternatives are available.

HOW TO BUILD A MODEL NUMBER

- A** Select basic model.
- B** Select foot option.
 FADJ - Adjustable
 FFLB - Flat/Bridge
- C** Select top cap style.
 F - Flat aluminum top cap (standard)
 N - No top cap (specify for use with toppers)
- D** Select frame/trim color. Refer to the **Product Color Options** page in this price list.
- E** Select lower laminate color. Refer to the **Product Color Options** page in this price list.
- F** Select upper polyester felt color. Refer to the **Product Color Options** page in this price list.

SPECIAL SERVICES

Special Carton Marking
 With specially marked information N/C

Shipping
 Ships assembled, FOB Manitowoc, WI 54220, freight prepaid. Freight class 70.

Specifications and prices are subject to change without prior notice.

Tattoo™ Flex Screens

Segmented Flex Screen with Thermally-Fused Laminate Lower, Polyester Felt Upper Core



Tattoo™ Flex Screens

Segmented Flex Screen with Thermally-Fused Laminate Lower, Polyester Felt Upper Core

MODEL	MODEL NUMBER						Approx. Packaged Weight	Delivered Pricing
	Basic Model	Foot Option	Top Cap Style	Frame/Trim Color	Lower Laminate Color	Upper Polyester Felt Color		
TFSMZ Segmented Flex Screen with Thermally-Fused Laminate Lower, Polyester Felt Upper Core - 60" H <ul style="list-style-type: none"> Flex screen assembly includes aluminum powder-coated frame, core material, all trim and feet Polyester felt upper segment is pinnable and non-magnetic Thermally-fused laminate is non-tackable and non-magnetic Specify adjustable glide feet or non-adjustable flat/bridge feet Non-powered; no wire management Fully assembled; includes all trim Slotting under upper trim accepts screen-hung accessories Segmentation at 29" Elevated base does not accept power 	TFSMZ4260	<input type="checkbox"/>	<input type="checkbox"/>	<input type="checkbox"/>	<input type="checkbox"/>	<input type="checkbox"/>	83.00#	\$ 1741
	TFSMZ4860	<input type="checkbox"/>	<input type="checkbox"/>	<input type="checkbox"/>	<input type="checkbox"/>	<input type="checkbox"/>	93.00#	1809
	TFSMZ5460	<input type="checkbox"/>	<input type="checkbox"/>	<input type="checkbox"/>	<input type="checkbox"/>	<input type="checkbox"/>	98.00#	2022
	TFSMZ6060	<input type="checkbox"/>	<input type="checkbox"/>	<input type="checkbox"/>	<input type="checkbox"/>	<input type="checkbox"/>	110.00#	2487
	TFSMZ6660	<input type="checkbox"/>	<input type="checkbox"/>	<input type="checkbox"/>	<input type="checkbox"/>	<input type="checkbox"/>	108.00#	2562
	TFSMZ7260	<input type="checkbox"/>	<input type="checkbox"/>	<input type="checkbox"/>	<input type="checkbox"/>	<input type="checkbox"/>	120.00#	2634
	TFSMZ7860	<input type="checkbox"/>	<input type="checkbox"/>	<input type="checkbox"/>	<input type="checkbox"/>	<input type="checkbox"/>	128.00#	2658
	TFSMZ8460	<input type="checkbox"/>	<input type="checkbox"/>	<input type="checkbox"/>	<input type="checkbox"/>	<input type="checkbox"/>	135.00#	2680
	TFSMZ9060	<input type="checkbox"/>	<input type="checkbox"/>	<input type="checkbox"/>	<input type="checkbox"/>	<input type="checkbox"/>	143.00#	2711
	TFSMZ9660	<input type="checkbox"/>	<input type="checkbox"/>	<input type="checkbox"/>	<input type="checkbox"/>	<input type="checkbox"/>	150.00#	2733
	A	B	C	D	E	F		

HOW TO ORDER

- Indicate the following information on order form:
- Quantity of each item.
 - Model number, including options. See "How To Build a Model Number".
 - Any special service required.

Note:

- The indicates that a choice is required.
- The absence of the indicates that no choice is required.
- Alpha-numeric characters in place of indicate that no other alternatives are available.

HOW TO BUILD A MODEL NUMBER

- A** Select basic model.
- B** Select foot option.

FADJ	- Adjustable
FFLB	- Flat/Bridge
- C** Select top cap style.

F	- Flat aluminum top cap (standard)
N	- No top cap (specify for use with toppers)
- D** Select frame/trim color. Refer to the **Product Color Options** page in this price list.
- E** Select lower laminate color. Refer to the **Product Color Options** page in this price list.
- F** Select upper polyester felt color. Refer to the **Product Color Options** page in this price list.

SPECIAL SERVICES

Special Carton Marking

With specially marked information N/C

Shipping

Ships **assembled, FOB Manitowoc, WI 54220, freight prepaid.** Freight class 70.

Specifications and prices are subject to change without prior notice.

Tattoo™ Flex Screens

Segmented Flex Screen with Thermally-Fused Laminate Lower, Fabric Upper Core



Tattoo™ Flex Screens

Segmented Flex Screen with Thermally-Fused Laminate Lower, Fabric Upper Core

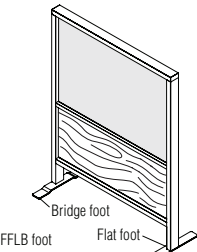
MODEL	MODEL NUMBER						Approx. Packaged Weight	Delivered Pricing Fabric Grade 1 & C.O.M.	Delivered Pricing Fabric Grade 2	Delivered Pricing Fabric Grade 3 & Pallas Vertical Fabric Grade PV	Delivered Pricing Pallas Vertical Fabric Grade PV1	Delivered Pricing Pallas Vertical Fabric Grade PV2
	Basic Model	Foot Option	Top Cap Style	Frame/Trim Color	Lower Laminate Color	Upper Fabric Color						
 <p>FFLB foot option shown</p> <p>TFSMF</p> <p>Segmented Flex Screen with Thermally-Fused Laminate Lower, Fabric Upper Core - 48" H</p> <ul style="list-style-type: none"> Flex screen assembly includes aluminum powder-coated frame, core material, all trim and feet Upper segment features identical tackable fabric core on both sides, fabric pattern is railroaded Thermally-fused laminate is non-tackable and non-magnetic Specify adjustable glide feet or non-adjustable flat/bridge feet Non-powered; no wire management Fully assembled; includes all trim Slotting under upper trim accepts screen-hung accessories Segmentation at 29" Elevated base does not accept power 	TFSMF4248	<input type="checkbox"/>	<input type="checkbox"/>	<input type="checkbox"/>	<input type="checkbox"/>	<input type="checkbox"/>	72.00#	\$ 1454	\$ 1483	\$ 1513	\$ 1527	\$ 1586
	TFSMF4848	<input type="checkbox"/>	<input type="checkbox"/>	<input type="checkbox"/>	<input type="checkbox"/>	<input type="checkbox"/>	78.00#	1516	1547	1577	1592	1652
	TFSMF5448	<input type="checkbox"/>	<input type="checkbox"/>	<input type="checkbox"/>	<input type="checkbox"/>	<input type="checkbox"/>	84.00#	1631	1663	1696	1712	1778
	TFSMF6048	<input type="checkbox"/>	<input type="checkbox"/>	<input type="checkbox"/>	<input type="checkbox"/>	<input type="checkbox"/>	90.00#	1749	1784	1817	1835	1905
	TFSMF6648	<input type="checkbox"/>	<input type="checkbox"/>	<input type="checkbox"/>	<input type="checkbox"/>	<input type="checkbox"/>	96.00#	1875	1914	1952	1971	2045
	TFSMF7248	<input type="checkbox"/>	<input type="checkbox"/>	<input type="checkbox"/>	<input type="checkbox"/>	<input type="checkbox"/>	102.00#	1948	1988	2028	2046	2125
	TFSMF7848	<input type="checkbox"/>	<input type="checkbox"/>	<input type="checkbox"/>	<input type="checkbox"/>	<input type="checkbox"/>	108.00#	2014	2054	2094	2116	2195
	TFSMF8448	<input type="checkbox"/>	<input type="checkbox"/>	<input type="checkbox"/>	<input type="checkbox"/>	<input type="checkbox"/>	114.00#	2040	2082	2121	2143	2224
	TFSMF9048	<input type="checkbox"/>	<input type="checkbox"/>	<input type="checkbox"/>	<input type="checkbox"/>	<input type="checkbox"/>	120.00#	2107	2149	2191	2211	2297
	TFSMF9648	<input type="checkbox"/>	<input type="checkbox"/>	<input type="checkbox"/>	<input type="checkbox"/>	<input type="checkbox"/>	126.00#	2128	2171	2214	2235	2320
TFSMF	TFSMF4254	<input type="checkbox"/>	<input type="checkbox"/>	<input type="checkbox"/>	<input type="checkbox"/>	<input type="checkbox"/>	78.00#	\$ 1486	\$ 1516	\$ 1546	\$ 1561	\$ 1620
	TFSMF4854	<input type="checkbox"/>	<input type="checkbox"/>	<input type="checkbox"/>	<input type="checkbox"/>	<input type="checkbox"/>	84.00#	1560	1591	1621	1635	1700
	TFSMF5454	<input type="checkbox"/>	<input type="checkbox"/>	<input type="checkbox"/>	<input type="checkbox"/>	<input type="checkbox"/>	91.00#	1675	1708	1742	1759	1825
	TFSMF6054	<input type="checkbox"/>	<input type="checkbox"/>	<input type="checkbox"/>	<input type="checkbox"/>	<input type="checkbox"/>	98.00#	1792	1829	1863	1882	1954
	TFSMF6654	<input type="checkbox"/>	<input type="checkbox"/>	<input type="checkbox"/>	<input type="checkbox"/>	<input type="checkbox"/>	100.00#	1922	1959	1998	2019	2093
	TFSMF7254	<input type="checkbox"/>	<input type="checkbox"/>	<input type="checkbox"/>	<input type="checkbox"/>	<input type="checkbox"/>	111.00#	1995	2034	2075	2094	2173
	TFSMF7854	<input type="checkbox"/>	<input type="checkbox"/>	<input type="checkbox"/>	<input type="checkbox"/>	<input type="checkbox"/>	118.00#	2061	2103	2143	2164	2247
	TFSMF8454	<input type="checkbox"/>	<input type="checkbox"/>	<input type="checkbox"/>	<input type="checkbox"/>	<input type="checkbox"/>	125.00#	2088	2130	2172	2192	2276
	TFSMF9054	<input type="checkbox"/>	<input type="checkbox"/>	<input type="checkbox"/>	<input type="checkbox"/>	<input type="checkbox"/>	132.00#	2154	2197	2242	2264	2348
	TFSMF9654	<input type="checkbox"/>	<input type="checkbox"/>	<input type="checkbox"/>	<input type="checkbox"/>	<input type="checkbox"/>	138.00#	2175	2219	2264	2283	2373

A **B** **C** **D** **E** **F**

HOW TO ORDER

- Indicate the following information on order form:
- Quantity of each item.
 - Model number, including options. See "How To Build a Model Number".
 - Any special service required.

Note:

- The indicates that a choice is required.
- The absence of the indicates that no choice is required.
- Alpha-numeric characters in place of indicate that no other alternatives are available.

HOW TO BUILD A MODEL NUMBER

- A** Select basic model.
- B** Select foot option.

FADJ	- Adjustable
FFLB	- Flat/Bridge
- C** Select top cap style.

F	- Flat aluminum top cap (standard)
N	- No top cap (specify for use with toppers)
- D** Select frame/trim color. Refer to the **Product Color Options** page in this price list.
- E** Select lower laminate color. Refer to the **Product Color Options** page in this price list.
- F** Select upper fabric color. Refer to ki.com/fabrics

INFORMATION

COM YARDAGE REQUIREMENTS

Screen Width/Length	Fabric Required
42	2.556
48	2.889
54	3.222
60	3.556
66	3.889
72	4.222
78	4.556
84	4.889
90	5.222
96	5.556

SPECIAL SERVICES

Special Carton Marking
With specially marked information N/C

Shipping
Ships assembled, FOB Manitowoc, WI 54220, freight prepaid. Freight class 70.

Specifications and prices are subject to change without prior notice.

Tattoo™ Flex Screens

Segmented Flex Screen with Thermally-Fused Laminate Lower, Fabric Upper Core



Tattoo™ Flex Screens

Segmented Flex Screen with Thermally-Fused Laminate Lower, Fabric Upper Core

MODEL	MODEL NUMBER						Approx. Packaged Weight	Delivered Pricing Fabric Grade 1 & C.O.M.	Delivered Pricing Fabric Grade 2	Delivered Pricing Fabric Grade 3 & Pallas Vertical Fabric Grade PV	Delivered Pricing Pallas Vertical Fabric Grade PV1	Delivered Pricing Pallas Vertical Fabric Grade PV2
	Basic Model	Foot Option	Top Cap Style	Frame/Trim Color	Lower Laminate Color	Upper Fabric Color						
TFSMF Segmented Flex Screen with Thermally-Fused Laminate Lower, Fabric Upper Core - 60" H <ul style="list-style-type: none"> Flex screen assembly includes aluminum powder-coated frame, core material, all trim and feet Upper segment features identical tackable fabric core on both sides, fabric pattern is railroaded Thermally-fused laminate is non-tackable and non-magnetic Specify adjustable glide feet or non-adjustable flat/bridge feet Non-powered; no wire management Fully assembled; includes all trim Slotting under upper trim accepts screen-hung accessories Segmentation at 29" Elevated base does not accept power 	TFSMF4260	<input type="checkbox"/> <input type="checkbox"/> <input type="checkbox"/> <input type="checkbox"/>	<input type="checkbox"/>	<input type="checkbox"/> <input type="checkbox"/>	<input type="checkbox"/> <input type="checkbox"/> <input type="checkbox"/> <input type="checkbox"/>	<input type="checkbox"/> <input type="checkbox"/> <input type="checkbox"/> <input type="checkbox"/> <input type="checkbox"/> <input type="checkbox"/>	83.00#	\$ 1751	\$ 1787	\$ 1821	\$ 1839	\$ 1909
	TFSMF4860	<input type="checkbox"/> <input type="checkbox"/> <input type="checkbox"/> <input type="checkbox"/>	<input type="checkbox"/>	<input type="checkbox"/> <input type="checkbox"/>	<input type="checkbox"/> <input type="checkbox"/> <input type="checkbox"/> <input type="checkbox"/>	<input type="checkbox"/> <input type="checkbox"/> <input type="checkbox"/> <input type="checkbox"/> <input type="checkbox"/> <input type="checkbox"/>	93.00#	1796	1834	1871	1889	1959
	TFSMF5460	<input type="checkbox"/> <input type="checkbox"/> <input type="checkbox"/> <input type="checkbox"/>	<input type="checkbox"/>	<input type="checkbox"/> <input type="checkbox"/>	<input type="checkbox"/> <input type="checkbox"/> <input type="checkbox"/> <input type="checkbox"/>	<input type="checkbox"/> <input type="checkbox"/> <input type="checkbox"/> <input type="checkbox"/> <input type="checkbox"/> <input type="checkbox"/>	98.00#	1872	1910	1947	1965	2040
	TFSMF6060	<input type="checkbox"/> <input type="checkbox"/> <input type="checkbox"/> <input type="checkbox"/>	<input type="checkbox"/>	<input type="checkbox"/> <input type="checkbox"/>	<input type="checkbox"/> <input type="checkbox"/> <input type="checkbox"/> <input type="checkbox"/>	<input type="checkbox"/> <input type="checkbox"/> <input type="checkbox"/> <input type="checkbox"/> <input type="checkbox"/> <input type="checkbox"/>	104.00#	1991	2030	2072	2089	2169
	TFSMF6660	<input type="checkbox"/> <input type="checkbox"/> <input type="checkbox"/> <input type="checkbox"/>	<input type="checkbox"/>	<input type="checkbox"/> <input type="checkbox"/>	<input type="checkbox"/> <input type="checkbox"/> <input type="checkbox"/> <input type="checkbox"/>	<input type="checkbox"/> <input type="checkbox"/> <input type="checkbox"/> <input type="checkbox"/> <input type="checkbox"/> <input type="checkbox"/>	108.00#	2171	2215	2257	2279	2365
	TFSMF7260	<input type="checkbox"/> <input type="checkbox"/> <input type="checkbox"/> <input type="checkbox"/>	<input type="checkbox"/>	<input type="checkbox"/> <input type="checkbox"/>	<input type="checkbox"/> <input type="checkbox"/> <input type="checkbox"/> <input type="checkbox"/>	<input type="checkbox"/> <input type="checkbox"/> <input type="checkbox"/> <input type="checkbox"/> <input type="checkbox"/> <input type="checkbox"/>	120.00#	2244	2289	2334	2356	2447
	TFSMF7860	<input type="checkbox"/> <input type="checkbox"/> <input type="checkbox"/> <input type="checkbox"/>	<input type="checkbox"/>	<input type="checkbox"/> <input type="checkbox"/>	<input type="checkbox"/> <input type="checkbox"/> <input type="checkbox"/> <input type="checkbox"/>	<input type="checkbox"/> <input type="checkbox"/> <input type="checkbox"/> <input type="checkbox"/> <input type="checkbox"/> <input type="checkbox"/>	128.00#	2310	2357	2404	2427	2519
	TFSMF8460	<input type="checkbox"/> <input type="checkbox"/> <input type="checkbox"/> <input type="checkbox"/>	<input type="checkbox"/>	<input type="checkbox"/> <input type="checkbox"/>	<input type="checkbox"/> <input type="checkbox"/> <input type="checkbox"/> <input type="checkbox"/>	<input type="checkbox"/> <input type="checkbox"/> <input type="checkbox"/> <input type="checkbox"/> <input type="checkbox"/> <input type="checkbox"/>	135.00#	2337	2386	2433	2457	2549
	TFSMF9060	<input type="checkbox"/> <input type="checkbox"/> <input type="checkbox"/> <input type="checkbox"/>	<input type="checkbox"/>	<input type="checkbox"/> <input type="checkbox"/>	<input type="checkbox"/> <input type="checkbox"/> <input type="checkbox"/> <input type="checkbox"/>	<input type="checkbox"/> <input type="checkbox"/> <input type="checkbox"/> <input type="checkbox"/> <input type="checkbox"/> <input type="checkbox"/>	143.00#	2415	2461	2506	2529	2620
	TFSMF9660	<input type="checkbox"/> <input type="checkbox"/> <input type="checkbox"/> <input type="checkbox"/>	<input type="checkbox"/>	<input type="checkbox"/> <input type="checkbox"/>	<input type="checkbox"/> <input type="checkbox"/> <input type="checkbox"/> <input type="checkbox"/>	<input type="checkbox"/> <input type="checkbox"/> <input type="checkbox"/> <input type="checkbox"/> <input type="checkbox"/> <input type="checkbox"/>	150.00#	2437	2483	2529	2551	2645

A **B** **C** **D** **E** **F**

HOW TO ORDER

- Indicate the following information on order form:
- Quantity of each item.
 - Model number, including options. See "How To Build a Model Number".
 - Any special service required.

Note:

- The indicates that a choice is required.
- The absence of the indicates that no choice is required.
- Alpha-numeric characters in place of indicate that no other alternatives are available.

HOW TO BUILD A MODEL NUMBER

- A** Select basic model.
- B** Select foot option.

FADJ	- Adjustable
FFLB	- Flat/Bridge
- C** Select top cap style.

F	- Flat aluminum top cap (standard)
N	- No top cap (specify for use with toppers)
- D** Select frame/trim color. Refer to the **Product Color Options** page in this price list.
- E** Select lower laminate color. Refer to the **Product Color Options** page in this price list.
- F** Select upper fabric color. Refer to ki.com/fabrics

INFORMATION

COM YARDAGE REQUIREMENTS	
Screen Width/Length	Fabric Required
42	2.556
48	2.889
54	3.222
60	3.556
66	3.889
72	4.222
78	4.556
84	4.889
90	5.222
96	5.556

SPECIAL SERVICES

Special Carton Marking

With specially marked information N/C

Shipping

Ships **assembled, FOB Manitowoc, WI 54220, freight prepaid.** Freight class 70.

Specifications and prices are subject to change without prior notice.

Tattoo™ Flex Screens

Segmented Flex Screen with Thermally-Fused Laminate Lower, Fluted Polycarbonate Upper Core



Tattoo™ Flex Screens

Segmented Flex Screen with Thermally-Fused Laminate Lower, Fluted Polycarbonate Upper Core

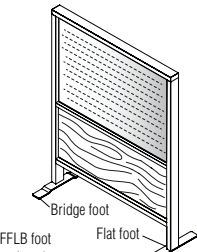
MODEL	MODEL NUMBER					Approx. Packaged Weight	Delivered Pricing
	Basic Model	Foot Option	Top Cap Style	Frame/Trim Color	Lower Laminate Color		
 <p>Segmented Flex Screen with Thermally-Fused Laminate Lower, Fluted Polycarbonate Upper Core - 48" H</p> <ul style="list-style-type: none"> Flex screen assembly includes aluminum powder-coated frame, core material, all trim and feet Fluted polycarbonate upper segment is non-tackable and non-magnetic Thermally-fused laminate is non-tackable and non-magnetic Specify adjustable glide feet or non-adjustable flat/bridge feet Non-powered; no wire management Fully assembled; includes all trim Slotting under upper trim accepts screen-hung accessories Segmentation at 29" Elevated base does not accept power Fluting runs horizontal 	TFSMP4248	<input type="checkbox"/>	<input type="checkbox"/>	<input type="checkbox"/>	<input type="checkbox"/>	72.00#	\$ 1390
	TFSMP4848	<input type="checkbox"/>	<input type="checkbox"/>	<input type="checkbox"/>	<input type="checkbox"/>	78.00#	1504
	TFSMP5448	<input type="checkbox"/>	<input type="checkbox"/>	<input type="checkbox"/>	<input type="checkbox"/>	84.00#	1646
	TFSMP6048	<input type="checkbox"/>	<input type="checkbox"/>	<input type="checkbox"/>	<input type="checkbox"/>	90.00#	1744
	TFSMP6648	<input type="checkbox"/>	<input type="checkbox"/>	<input type="checkbox"/>	<input type="checkbox"/>	96.00#	1843
	TFSMP7248	<input type="checkbox"/>	<input type="checkbox"/>	<input type="checkbox"/>	<input type="checkbox"/>	102.00#	1943
	TFSMP7848	<input type="checkbox"/>	<input type="checkbox"/>	<input type="checkbox"/>	<input type="checkbox"/>	108.00#	1990
	TFSMP8448	<input type="checkbox"/>	<input type="checkbox"/>	<input type="checkbox"/>	<input type="checkbox"/>	114.00#	2036
	TFSMP9048	<input type="checkbox"/>	<input type="checkbox"/>	<input type="checkbox"/>	<input type="checkbox"/>	120.00#	2085
	TFSMP9648	<input type="checkbox"/>	<input type="checkbox"/>	<input type="checkbox"/>	<input type="checkbox"/>	126.00#	2132
TFSMP	TFSMP4254	<input type="checkbox"/>	<input type="checkbox"/>	<input type="checkbox"/>	<input type="checkbox"/>	78.00#	\$ 1419
	TFSMP4854	<input type="checkbox"/>	<input type="checkbox"/>	<input type="checkbox"/>	<input type="checkbox"/>	84.00#	1547
	TFSMP5454	<input type="checkbox"/>	<input type="checkbox"/>	<input type="checkbox"/>	<input type="checkbox"/>	91.00#	1689
	TFSMP6054	<input type="checkbox"/>	<input type="checkbox"/>	<input type="checkbox"/>	<input type="checkbox"/>	98.00#	1788
	TFSMP6654	<input type="checkbox"/>	<input type="checkbox"/>	<input type="checkbox"/>	<input type="checkbox"/>	100.00#	1889
	TFSMP7254	<input type="checkbox"/>	<input type="checkbox"/>	<input type="checkbox"/>	<input type="checkbox"/>	111.00#	1988
	TFSMP7854	<input type="checkbox"/>	<input type="checkbox"/>	<input type="checkbox"/>	<input type="checkbox"/>	118.00#	2035
	TFSMP8454	<input type="checkbox"/>	<input type="checkbox"/>	<input type="checkbox"/>	<input type="checkbox"/>	125.00#	2085
	TFSMP9054	<input type="checkbox"/>	<input type="checkbox"/>	<input type="checkbox"/>	<input type="checkbox"/>	132.00#	2133
	TFSMP9654	<input type="checkbox"/>	<input type="checkbox"/>	<input type="checkbox"/>	<input type="checkbox"/>	138.00#	2181

A **B** **C** **D** **E**

HOW TO ORDER

- Indicate the following information on order form:
- Quantity of each item.
 - Model number, including options. See "How To Build a Model Number".
 - Any special service required.

Note:

- The indicates that a choice is required.
- The absence of the indicates that no choice is required.
- Alpha-numeric characters in place of indicate that no other alternatives are available.

HOW TO BUILD A MODEL NUMBER

- A** Select basic model.
- B** Select foot option.

FADJ	- Adjustable
FFLB	- Flat/Bridge
- C** Select top cap style.

F	- Flat aluminum top cap (standard)
N	- No top cap (specify for use with toppers)
- D** Select frame/trim color. Refer to the **Product Color Options** page in this price list.
- E** Select lower laminate color. Refer to the **Product Color Options** page in this price list.

SPECIAL SERVICES

Special Carton Marking
 With specially marked information N/C

Shipping
 Ships assembled, FOB Manitowoc, WI 54220, freight prepaid. Freight class 70.

Specifications and prices are subject to change without prior notice.

Tattoo™ Flex Screens

Segmented Flex Screen with Thermally-Fused Laminate Lower, Fluted Polycarbonate Upper Core



Tattoo™ Flex Screens

Segmented Flex Screen with Thermally-Fused Laminate Lower, Fluted Polycarbonate Upper Core

MODEL	MODEL NUMBER					Approx. Packaged Weight	Delivered Pricing
	Basic Model	Foot Option	Top Cap Style	Frame/Trim Color	Lower Laminate Color		
TFSMP Segmented Flex Screen with Thermally-Fused Laminate Lower, Fluted Polycarbonate Upper Core - 60" H <ul style="list-style-type: none"> Flex screen assembly includes aluminum powder-coated frame, core material, all trim and feet Fluted polycarbonate upper segment is non-tackable and non-magnetic Thermally-fused laminate is non-tackable and non-magnetic Specify adjustable glide feet or non-adjustable flat/bridge feet Non-powered; no wire management Fully assembled; includes all trim Slotting under upper trim accepts screen-hung accessories Segmentation at 29" Elevated base does not accept power Fluting runs horizontal 	TFSMP4260	<input type="checkbox"/>	<input type="checkbox"/>	<input type="checkbox"/>	<input type="checkbox"/>	83.00#	\$ 1678
	TFSMP4860	<input type="checkbox"/>	<input type="checkbox"/>	<input type="checkbox"/>	<input type="checkbox"/>	93.00#	1734
	TFSMP5460	<input type="checkbox"/>	<input type="checkbox"/>	<input type="checkbox"/>	<input type="checkbox"/>	98.00#	1837
	TFSMP6060	<input type="checkbox"/>	<input type="checkbox"/>	<input type="checkbox"/>	<input type="checkbox"/>	104.00#	1937
	TFSMP6660	<input type="checkbox"/>	<input type="checkbox"/>	<input type="checkbox"/>	<input type="checkbox"/>	108.00#	2036
	TFSMP7260	<input type="checkbox"/>	<input type="checkbox"/>	<input type="checkbox"/>	<input type="checkbox"/>	120.00#	2137
	TFSMP7860	<input type="checkbox"/>	<input type="checkbox"/>	<input type="checkbox"/>	<input type="checkbox"/>	128.00#	2186
	TFSMP8460	<input type="checkbox"/>	<input type="checkbox"/>	<input type="checkbox"/>	<input type="checkbox"/>	135.00#	2235
	TFSMP9060	<input type="checkbox"/>	<input type="checkbox"/>	<input type="checkbox"/>	<input type="checkbox"/>	143.00#	2292
	TFSMP9660	<input type="checkbox"/>	<input type="checkbox"/>	<input type="checkbox"/>	<input type="checkbox"/>	150.00#	2342
	A	B	C	D	E		

HOW TO ORDER

- Indicate the following information on order form:
- Quantity of each item.
 - Model number, including options. See "How To Build a Model Number".
 - Any special service required.

Note:

- The indicates that a choice is required.
- The absence of the indicates that no choice is required.
- Alpha-numeric characters in place of indicate that no other alternatives are available.

HOW TO BUILD A MODEL NUMBER

- A** Select basic model.
- B** Select foot option.

FADJ	- Adjustable
FFLB	- Flat/Bridge
- C** Select top cap style.

F	- Flat aluminum top cap (standard)
N	- No top cap (specify for use with toppers)
- D** Select frame/trim color. Refer to the **Product Color Options** page in this price list.
- E** Select lower laminate color. Refer to the **Product Color Options** page in this price list.

SPECIAL SERVICES

Special Carton Marking

With specially marked information N/C

Shipping

Ships **assembled, FOB Manitowoc, WI 54220, freight prepaid.** Freight class 70.

Specifications and prices are subject to change without prior notice.

Tattoo™ Flex Screens

Segmented Flex Screen with Thermally-Fused Laminate Lower, Acrylic Upper Core



Tattoo™ Flex Screens

Segmented Flex Screen with Thermally-Fused Laminate Lower, Acrylic Upper Core

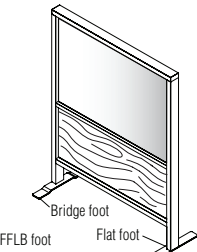
MODEL	MODEL NUMBER						Approx. Packaged Weight	Delivered Pricing
	Basic Model	Foot Option	Top Cap Style	Frame/Trim Color	Lower Laminate Color	Upper Acrylic Finish		
 <p>FFLB foot option shown</p> <p>TFSMA</p> <p>Segmented Flex Screen with Thermally-Fused Laminate Lower, Acrylic Upper Core - 48" H</p> <ul style="list-style-type: none"> Flex screen assembly includes aluminum powder-coated frame, core material, all trim and feet Acrylic upper segment is non-tackable and non-magnetic Thermally-fused laminate is non-tackable and non-magnetic Aluminum frame features powder-coated trim Specify adjustable glide feet or non-adjustable flat/bridge feet Non-powered; no wire management Fully assembled; includes all trim Slotting under upper trim accepts screen-hung accessories Segmentation at 29" Elevated base does not accept power 	TFSMA4248	<input type="checkbox"/>	<input type="checkbox"/>	<input type="checkbox"/>	<input type="checkbox"/>	<input type="checkbox"/>	78.00#	\$ 1550
	TFSMA4848	<input type="checkbox"/>	<input type="checkbox"/>	<input type="checkbox"/>	<input type="checkbox"/>	<input type="checkbox"/>	85.00#	1603
	TFSMA5448	<input type="checkbox"/>	<input type="checkbox"/>	<input type="checkbox"/>	<input type="checkbox"/>	<input type="checkbox"/>	92.00#	1759
	TFSMA6048	<input type="checkbox"/>	<input type="checkbox"/>	<input type="checkbox"/>	<input type="checkbox"/>	<input type="checkbox"/>	99.00#	1833
	TFSMA6648	<input type="checkbox"/>	<input type="checkbox"/>	<input type="checkbox"/>	<input type="checkbox"/>	<input type="checkbox"/>	106.00#	1956
	TFSMA7248	<input type="checkbox"/>	<input type="checkbox"/>	<input type="checkbox"/>	<input type="checkbox"/>	<input type="checkbox"/>	113.00#	2094
	TFSMA7848	<input type="checkbox"/>	<input type="checkbox"/>	<input type="checkbox"/>	<input type="checkbox"/>	<input type="checkbox"/>	120.00#	2118
	TFSMA8448	<input type="checkbox"/>	<input type="checkbox"/>	<input type="checkbox"/>	<input type="checkbox"/>	<input type="checkbox"/>	127.00#	2374
	TFSMA9048	<input type="checkbox"/>	<input type="checkbox"/>	<input type="checkbox"/>	<input type="checkbox"/>	<input type="checkbox"/>	134.00#	2397
	TFSMA9648	<input type="checkbox"/>	<input type="checkbox"/>	<input type="checkbox"/>	<input type="checkbox"/>	<input type="checkbox"/>	141.00#	2419
TFSMA	TFSMA4254	<input type="checkbox"/>	<input type="checkbox"/>	<input type="checkbox"/>	<input type="checkbox"/>	<input type="checkbox"/>	85.00#	\$ 1698
	TFSMA4854	<input type="checkbox"/>	<input type="checkbox"/>	<input type="checkbox"/>	<input type="checkbox"/>	<input type="checkbox"/>	93.00#	1759
	TFSMA5454	<input type="checkbox"/>	<input type="checkbox"/>	<input type="checkbox"/>	<input type="checkbox"/>	<input type="checkbox"/>	101.00#	1944
	TFSMA6054	<input type="checkbox"/>	<input type="checkbox"/>	<input type="checkbox"/>	<input type="checkbox"/>	<input type="checkbox"/>	109.00#	2019
	TFSMA6654	<input type="checkbox"/>	<input type="checkbox"/>	<input type="checkbox"/>	<input type="checkbox"/>	<input type="checkbox"/>	117.00#	2188
	TFSMA7254	<input type="checkbox"/>	<input type="checkbox"/>	<input type="checkbox"/>	<input type="checkbox"/>	<input type="checkbox"/>	125.00#	2264
	TFSMA7854	<input type="checkbox"/>	<input type="checkbox"/>	<input type="checkbox"/>	<input type="checkbox"/>	<input type="checkbox"/>	133.00#	2430
	TFSMA8454	<input type="checkbox"/>	<input type="checkbox"/>	<input type="checkbox"/>	<input type="checkbox"/>	<input type="checkbox"/>	141.00#	2695
	TFSMA9054	<input type="checkbox"/>	<input type="checkbox"/>	<input type="checkbox"/>	<input type="checkbox"/>	<input type="checkbox"/>	149.00#	2718
	TFSMA9654	<input type="checkbox"/>	<input type="checkbox"/>	<input type="checkbox"/>	<input type="checkbox"/>	<input type="checkbox"/>	157.00#	2743

A **B** **C** **D** **E** **F**

HOW TO ORDER

- Indicate the following information on order form:
- Quantity of each item.
 - Model number, including options. See "How To Build a Model Number".
 - Any special service required.

Note:

- The indicates that a choice is required.
- The absence of the indicates that no choice is required.
- Alpha-numeric characters in place of indicate that no other alternatives are available.

HOW TO BUILD A MODEL NUMBER

- A** Select basic model.
- B** Select foot option.

FADJ	- Adjustable
FFLB	- Flat/Bridge
- C** Select top cap style.

F	- Flat aluminum top cap (standard)
N	- No top cap (specify for use with toppers)
- D** Select frame/trim color. Refer to the **Product Color Options** page in this price list.
- E** Select lower laminate color. Refer to the **Product Color Options** page in this price list.
- F** Select upper acrylic finish. Refer to the **Product Color Options** page in this price list.

SPECIAL SERVICES

Special Carton Marking
 With specially marked information N/C

Shipping
 Ships assembled, FOB Manitowoc, WI 54220, freight prepaid. Freight class 70.

Specifications and prices are subject to change without prior notice.

Tattoo™ Flex Screens

Segmented Flex Screen with Thermally-Fused Laminate Lower, Acrylic Upper Core



Tattoo™ Flex Screens

Segmented Flex Screen with Thermally-Fused Laminate Lower, Acrylic Upper Core

MODEL	MODEL NUMBER						Approx. Packaged Weight	Delivered Pricing
	Basic Model	Foot Option	Top Cap Style	Frame/Trim Color	Lower Laminate Color	Upper Acrylic Finish		
TFSMA Segmented Flex Screen with Thermally-Fused Laminate Lower, Acrylic Upper Core - 60" H <ul style="list-style-type: none"> Flex screen assembly includes aluminum powder-coated frame, core material, all trim and feet Acrylic upper segment is non-tackable and non-magnetic Thermally-fused laminate is non-tackable and non-magnetic Aluminum frame features powder-coated trim Specify adjustable glide feet or non-adjustable flat/bridge feet Non-powered; no wire management Fully assembled; includes all trim Slotting under upper trim accepts screen-hung accessories Segmentation at 29" Elevated base does not accept power 	TFSMA4260	<input type="checkbox"/> <input type="checkbox"/> <input type="checkbox"/> <input type="checkbox"/>	<input type="checkbox"/>	<input type="checkbox"/> <input type="checkbox"/>	<input type="checkbox"/> <input type="checkbox"/> <input type="checkbox"/> <input type="checkbox"/>	<input type="checkbox"/> <input type="checkbox"/>	92.00#	\$ 2034
	TFSMA4860	<input type="checkbox"/> <input type="checkbox"/> <input type="checkbox"/> <input type="checkbox"/>	<input type="checkbox"/>	<input type="checkbox"/> <input type="checkbox"/>	<input type="checkbox"/> <input type="checkbox"/> <input type="checkbox"/> <input type="checkbox"/>	<input type="checkbox"/> <input type="checkbox"/>	101.00#	2127
	TFSMA5460	<input type="checkbox"/> <input type="checkbox"/> <input type="checkbox"/> <input type="checkbox"/>	<input type="checkbox"/>	<input type="checkbox"/> <input type="checkbox"/>	<input type="checkbox"/> <input type="checkbox"/> <input type="checkbox"/> <input type="checkbox"/>	<input type="checkbox"/> <input type="checkbox"/>	110.00#	2348
	TFSMA6060	<input type="checkbox"/> <input type="checkbox"/> <input type="checkbox"/> <input type="checkbox"/>	<input type="checkbox"/>	<input type="checkbox"/> <input type="checkbox"/>	<input type="checkbox"/> <input type="checkbox"/> <input type="checkbox"/> <input type="checkbox"/>	<input type="checkbox"/> <input type="checkbox"/>	119.00#	2426
	TFSMA6660	<input type="checkbox"/> <input type="checkbox"/> <input type="checkbox"/> <input type="checkbox"/>	<input type="checkbox"/>	<input type="checkbox"/> <input type="checkbox"/>	<input type="checkbox"/> <input type="checkbox"/> <input type="checkbox"/> <input type="checkbox"/>	<input type="checkbox"/> <input type="checkbox"/>	128.00#	2745
	TFSMA7260	<input type="checkbox"/> <input type="checkbox"/> <input type="checkbox"/> <input type="checkbox"/>	<input type="checkbox"/>	<input type="checkbox"/> <input type="checkbox"/>	<input type="checkbox"/> <input type="checkbox"/> <input type="checkbox"/> <input type="checkbox"/>	<input type="checkbox"/> <input type="checkbox"/>	137.00#	2823
	TFSMA7860	<input type="checkbox"/> <input type="checkbox"/> <input type="checkbox"/> <input type="checkbox"/>	<input type="checkbox"/>	<input type="checkbox"/> <input type="checkbox"/>	<input type="checkbox"/> <input type="checkbox"/> <input type="checkbox"/> <input type="checkbox"/>	<input type="checkbox"/> <input type="checkbox"/>	146.00#	2847
	TFSMA8460	<input type="checkbox"/> <input type="checkbox"/> <input type="checkbox"/> <input type="checkbox"/>	<input type="checkbox"/>	<input type="checkbox"/> <input type="checkbox"/>	<input type="checkbox"/> <input type="checkbox"/> <input type="checkbox"/> <input type="checkbox"/>	<input type="checkbox"/> <input type="checkbox"/>	155.00#	3367
	TFSMA9060	<input type="checkbox"/> <input type="checkbox"/> <input type="checkbox"/> <input type="checkbox"/>	<input type="checkbox"/>	<input type="checkbox"/> <input type="checkbox"/>	<input type="checkbox"/> <input type="checkbox"/> <input type="checkbox"/> <input type="checkbox"/>	<input type="checkbox"/> <input type="checkbox"/>	164.00#	3404
	TFSMA9660	<input type="checkbox"/> <input type="checkbox"/> <input type="checkbox"/> <input type="checkbox"/>	<input type="checkbox"/>	<input type="checkbox"/> <input type="checkbox"/>	<input type="checkbox"/> <input type="checkbox"/> <input type="checkbox"/> <input type="checkbox"/>	<input type="checkbox"/> <input type="checkbox"/>	173.00#	3429
	A	B	C	D	E	F		

HOW TO ORDER

- Indicate the following information on order form:
- Quantity of each item.
 - Model number, including options. See "How To Build a Model Number".
 - Any special service required.

Note:

- The indicates that a choice is required.
- The absence of the indicates that no choice is required.
- Alpha-numeric characters in place of indicate that no other alternatives are available.

HOW TO BUILD A MODEL NUMBER

- A** Select basic model.
- B** Select foot option.

FADJ	- Adjustable
FFLB	- Flat/Bridge
- C** Select top cap style.

F	- Flat aluminum top cap (standard)
N	- No top cap (specify for use with toppers)
- D** Select frame/trim color. Refer to the **Product Color Options** page in this price list.
- E** Select lower laminate color. Refer to the **Product Color Options** page in this price list.
- F** Select upper acrylic finish. Refer to the **Product Color Options** page in this price list.

SPECIAL SERVICES

Special Carton Marking

With specially marked information N/C

Shipping

Ships **assembled, FOB Manitowoc, WI 54220, freight prepaid.** Freight class 70.

Specifications and prices are subject to change without prior notice.

Tattoo™ Flex Screens

Segmented Flex Screen with Polyester Felt Lower, Magnetic Dry-Erasable Steel Upper Core



Tattoo™ Flex Screens

Segmented Flex Screen with Polyester Felt Lower, Magnetic Dry-Erasable Steel Upper Core

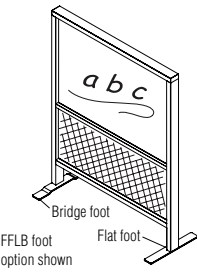
MODEL	MODEL NUMBER					Approx. Packaged Weight	Delivered Pricing
	Basic Model	Foot Option	Top Cap Style	Frame/Trim Color	Lower Polyester Felt Color		
 <p>TFSZE</p> <p>Segmented Flex Screen with Polyester Felt Lower, Magnetic Dry-Erasable Steel Upper Core - 48" H</p> <ul style="list-style-type: none"> Flex screen assembly includes aluminum powder-coated frame, core material, all trim, and feet Magnetic dry-erasable steel upper segment Polyester felt is pinnable and non-magnetic Specify adjustable glide feet or non-adjustable flat/bridge feet Non-powered; no wire management Fully assembled; includes all trim Slotting under upper trim accepts screen-hung accessories Segmentation at 29" Elevated base does not accept power 	TFSZE4248	<input type="checkbox"/>	<input type="checkbox"/>	<input type="checkbox"/>	<input type="checkbox"/>	72.00#	\$ 1481
	TFSZE4848	<input type="checkbox"/>	<input type="checkbox"/>	<input type="checkbox"/>	<input type="checkbox"/>	78.00#	1576
	TFSZE5448	<input type="checkbox"/>	<input type="checkbox"/>	<input type="checkbox"/>	<input type="checkbox"/>	84.00#	1749
	TFSZE6048	<input type="checkbox"/>	<input type="checkbox"/>	<input type="checkbox"/>	<input type="checkbox"/>	90.00#	2028
	TFSZE6648	<input type="checkbox"/>	<input type="checkbox"/>	<input type="checkbox"/>	<input type="checkbox"/>	96.00#	2150
	TFSZE7248	<input type="checkbox"/>	<input type="checkbox"/>	<input type="checkbox"/>	<input type="checkbox"/>	102.00#	2223
	TFSZE7848	<input type="checkbox"/>	<input type="checkbox"/>	<input type="checkbox"/>	<input type="checkbox"/>	108.00#	2293
	TFSZE8448	<input type="checkbox"/>	<input type="checkbox"/>	<input type="checkbox"/>	<input type="checkbox"/>	114.00#	2365
	TFSZE9048	<input type="checkbox"/>	<input type="checkbox"/>	<input type="checkbox"/>	<input type="checkbox"/>	120.00#	2387
	TFSZE9648	<input type="checkbox"/>	<input type="checkbox"/>	<input type="checkbox"/>	<input type="checkbox"/>	126.00#	2407
TFSZE	TFSZE4254	<input type="checkbox"/>	<input type="checkbox"/>	<input type="checkbox"/>	<input type="checkbox"/>	78.00#	\$ 1588
	TFSZE4854	<input type="checkbox"/>	<input type="checkbox"/>	<input type="checkbox"/>	<input type="checkbox"/>	84.00#	1669
	TFSZE5454	<input type="checkbox"/>	<input type="checkbox"/>	<input type="checkbox"/>	<input type="checkbox"/>	91.00#	1792
	TFSZE6054	<input type="checkbox"/>	<input type="checkbox"/>	<input type="checkbox"/>	<input type="checkbox"/>	98.00#	2073
	TFSZE6654	<input type="checkbox"/>	<input type="checkbox"/>	<input type="checkbox"/>	<input type="checkbox"/>	100.00#	2195
	TFSZE7254	<input type="checkbox"/>	<input type="checkbox"/>	<input type="checkbox"/>	<input type="checkbox"/>	111.00#	2269
	TFSZE7854	<input type="checkbox"/>	<input type="checkbox"/>	<input type="checkbox"/>	<input type="checkbox"/>	118.00#	2390
	TFSZE8454	<input type="checkbox"/>	<input type="checkbox"/>	<input type="checkbox"/>	<input type="checkbox"/>	125.00#	2412
	TFSZE9054	<input type="checkbox"/>	<input type="checkbox"/>	<input type="checkbox"/>	<input type="checkbox"/>	132.00#	2434
	TFSZE9654	<input type="checkbox"/>	<input type="checkbox"/>	<input type="checkbox"/>	<input type="checkbox"/>	138.00#	2457

A **B** **C** **D** **E**

HOW TO ORDER

- Indicate the following information on order form:
- Quantity of each item.
 - Model number, including options. See "How To Build a Model Number".
 - Any special service required.

Note:

- The indicates that a choice is required.
- The absence of the indicates that no choice is required.
- Alpha-numeric characters in place of indicate that no other alternatives are available.

HOW TO BUILD A MODEL NUMBER

- A** Select basic model.
- B** Select foot option.

FADJ	- Adjustable
FFLB	- Flat/Bridge
- C** Select top cap style.

F	- Flat aluminum top cap (standard)
N	- No top cap (specify for use with toppers)
- D** Select frame/trim color.
Refer to the **Product Color Options** page in this price list.
- E** Select lower polyester felt color.
Refer to the **Product Color Options** page in this price list.

SPECIAL SERVICES

Special Carton Marking
With specially marked information N/C

Shipping
Ships assembled, FOB Manitowoc, WI 54220, freight prepaid. Freight class 70.

Specifications and prices are subject to change without prior notice.

Tattoo™ Flex Screens

Segmented Flex Screen with Polyester Felt Lower and Thermally-Fused Laminate Upper Core



Tattoo™ Flex Screens

Segmented Flex Screen with Polyester Felt Lower and Thermally-Fused Laminate Upper Core

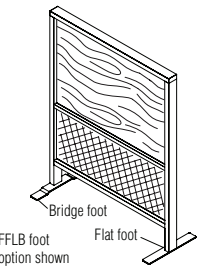
MODEL	MODEL NUMBER						Approx. Packaged Weight	Delivered Pricing
	Basic Model	Foot Option	Top Cap Style	Frame/Trim Color	Lower Polyester Felt Color	Upper Laminate Color		
 <p>FFLB foot option shown</p> <p>TFSZM</p> <p>Segmented Flex Screen with Polyester Felt Lower and Thermally-Fused Laminate Upper Core - 48" H</p> <ul style="list-style-type: none"> Flex screen assembly includes aluminum powder-coated frame, core material, all trim, and feet Thermally-fused laminate is non-tackable and non-magnetic Polyester felt is pinnable and non-magnetic Specify adjustable glide feet or non-adjustable flat/bridge feet Non-powered; no wire management Fully assembled; includes all trim Slotting under upper trim accepts screen-hung accessories Segmentation at 29" Elevated base does not accept power 	TFSZM4248	<input type="checkbox"/>	<input type="checkbox"/>	<input type="checkbox"/>	<input type="checkbox"/>	<input type="checkbox"/>	72.00#	\$ 1395
	TFSZM4848	<input type="checkbox"/>	<input type="checkbox"/>	<input type="checkbox"/>	<input type="checkbox"/>	<input type="checkbox"/>	78.00#	1495
	TFSZM5448	<input type="checkbox"/>	<input type="checkbox"/>	<input type="checkbox"/>	<input type="checkbox"/>	<input type="checkbox"/>	84.00#	1595
	TFSZM6048	<input type="checkbox"/>	<input type="checkbox"/>	<input type="checkbox"/>	<input type="checkbox"/>	<input type="checkbox"/>	90.00#	1875
	TFSZM6648	<input type="checkbox"/>	<input type="checkbox"/>	<input type="checkbox"/>	<input type="checkbox"/>	<input type="checkbox"/>	96.00#	1948
	TFSZM7248	<input type="checkbox"/>	<input type="checkbox"/>	<input type="checkbox"/>	<input type="checkbox"/>	<input type="checkbox"/>	102.00#	2021
	TFSZM7848	<input type="checkbox"/>	<input type="checkbox"/>	<input type="checkbox"/>	<input type="checkbox"/>	<input type="checkbox"/>	108.00#	2042
	TFSZM8448	<input type="checkbox"/>	<input type="checkbox"/>	<input type="checkbox"/>	<input type="checkbox"/>	<input type="checkbox"/>	114.00#	2062
	TFSZM9048	<input type="checkbox"/>	<input type="checkbox"/>	<input type="checkbox"/>	<input type="checkbox"/>	<input type="checkbox"/>	120.00#	2085
	TFSZM9648	<input type="checkbox"/>	<input type="checkbox"/>	<input type="checkbox"/>	<input type="checkbox"/>	<input type="checkbox"/>	126.00#	2106
TFSZM	TFSZM4254	<input type="checkbox"/>	<input type="checkbox"/>	<input type="checkbox"/>	<input type="checkbox"/>	<input type="checkbox"/>	78.00#	\$ 1434
	TFSZM4854	<input type="checkbox"/>	<input type="checkbox"/>	<input type="checkbox"/>	<input type="checkbox"/>	<input type="checkbox"/>	84.00#	1551
	TFSZM5454	<input type="checkbox"/>	<input type="checkbox"/>	<input type="checkbox"/>	<input type="checkbox"/>	<input type="checkbox"/>	91.00#	1667
	TFSZM6054	<input type="checkbox"/>	<input type="checkbox"/>	<input type="checkbox"/>	<input type="checkbox"/>	<input type="checkbox"/>	98.00#	1947
	TFSZM6654	<input type="checkbox"/>	<input type="checkbox"/>	<input type="checkbox"/>	<input type="checkbox"/>	<input type="checkbox"/>	100.00#	2022
	TFSZM7254	<input type="checkbox"/>	<input type="checkbox"/>	<input type="checkbox"/>	<input type="checkbox"/>	<input type="checkbox"/>	111.00#	2094
	TFSZM7854	<input type="checkbox"/>	<input type="checkbox"/>	<input type="checkbox"/>	<input type="checkbox"/>	<input type="checkbox"/>	118.00#	2117
	TFSZM8454	<input type="checkbox"/>	<input type="checkbox"/>	<input type="checkbox"/>	<input type="checkbox"/>	<input type="checkbox"/>	125.00#	2138
	TFSZM9054	<input type="checkbox"/>	<input type="checkbox"/>	<input type="checkbox"/>	<input type="checkbox"/>	<input type="checkbox"/>	132.00#	2160
	TFSZM9654	<input type="checkbox"/>	<input type="checkbox"/>	<input type="checkbox"/>	<input type="checkbox"/>	<input type="checkbox"/>	138.00#	2182

A **B** **C** **D** **E** **F**

HOW TO ORDER

- Indicate the following information on order form:
- Quantity of each item.
 - Model number, including options. See "How To Build a Model Number".
 - Any special service required.

Note: • The indicates that a choice is required.
 • The absence of the indicates that no choice is required.
 • Alpha-numeric characters in place of indicate that no other alternatives are available.

HOW TO BUILD A MODEL NUMBER

- A** Select basic model.
- B** Select foot option.

FADJ	- Adjustable
FFLB	- Flat/Bridge
- C** Select top cap style.

F	- Flat aluminum top cap (standard)
N	- No top cap (specify for use with toppers)
- D** Select frame/trim color.
Refer to the **Product Color Options** page in this price list.
- E** Select lower polyester felt color.
Refer to the **Product Color Options** page in this price list.
- F** Select upper laminate.
Refer to the **Product Color Options** page in this price list.

SPECIAL SERVICES

Special Carton Marking

With specially marked information N/C

Shipping

Ships assembled, FOB Manitowoc, WI 54220, freight prepaid. Freight class 70.

Specifications and prices are subject to change without prior notice.

Tattoo™ Flex Screens

Segmented Flex Screen with Polyester Felt Lower and Thermally-Fused Laminate Upper Core



Tattoo™ Flex Screens

Segmented Flex Screen with Polyester Felt Lower and Thermally-Fused Laminate Upper Core

MODEL	MODEL NUMBER						Approx. Packaged Weight	Delivered Pricing
	Basic Model	Foot Option	Top Cap Style	Frame/Trim Color	Lower Polyester Felt Color	Upper Laminate Color		
TFSZM Segmented Flex Screen with Polyester Felt Lower and Thermally-Fused Laminate Upper Core - 60" H <ul style="list-style-type: none"> Flex screen assembly includes aluminum powder-coated frame, core material, all trim, and feet Thermally-fused laminate is non-tackable and non-magnetic Polyester felt is pinnable and non-magnetic Specify adjustable glide feet or non-adjustable flat/bridge feet Non-powered; no wire management Fully assembled; includes all trim Slotting under upper trim accepts screen-hung accessories Segmentation at 29" Elevated base does not accept power 	TFSZM4260	<input type="checkbox"/> <input type="checkbox"/> <input type="checkbox"/> <input type="checkbox"/>	<input type="checkbox"/>	<input type="checkbox"/> <input type="checkbox"/>	<input type="checkbox"/> <input type="checkbox"/> <input type="checkbox"/> <input type="checkbox"/> <input type="checkbox"/> <input type="checkbox"/>	<input type="checkbox"/> <input type="checkbox"/> <input type="checkbox"/> <input type="checkbox"/>	83.00#	\$ 1574
	TFSZM4860	<input type="checkbox"/> <input type="checkbox"/> <input type="checkbox"/> <input type="checkbox"/>	<input type="checkbox"/>	<input type="checkbox"/> <input type="checkbox"/>	<input type="checkbox"/> <input type="checkbox"/> <input type="checkbox"/> <input type="checkbox"/> <input type="checkbox"/> <input type="checkbox"/>	<input type="checkbox"/> <input type="checkbox"/> <input type="checkbox"/> <input type="checkbox"/>	93.00#	1699
	TFSZM5460	<input type="checkbox"/> <input type="checkbox"/> <input type="checkbox"/> <input type="checkbox"/>	<input type="checkbox"/>	<input type="checkbox"/> <input type="checkbox"/>	<input type="checkbox"/> <input type="checkbox"/> <input type="checkbox"/> <input type="checkbox"/> <input type="checkbox"/> <input type="checkbox"/>	<input type="checkbox"/> <input type="checkbox"/> <input type="checkbox"/> <input type="checkbox"/>	98.00#	1815
	TFSZM6060	<input type="checkbox"/> <input type="checkbox"/> <input type="checkbox"/> <input type="checkbox"/>	<input type="checkbox"/>	<input type="checkbox"/> <input type="checkbox"/>	<input type="checkbox"/> <input type="checkbox"/> <input type="checkbox"/> <input type="checkbox"/> <input type="checkbox"/> <input type="checkbox"/>	<input type="checkbox"/> <input type="checkbox"/> <input type="checkbox"/> <input type="checkbox"/>	104.00#	2095
	TFSZM6660	<input type="checkbox"/> <input type="checkbox"/> <input type="checkbox"/> <input type="checkbox"/>	<input type="checkbox"/>	<input type="checkbox"/> <input type="checkbox"/>	<input type="checkbox"/> <input type="checkbox"/> <input type="checkbox"/> <input type="checkbox"/> <input type="checkbox"/> <input type="checkbox"/>	<input type="checkbox"/> <input type="checkbox"/> <input type="checkbox"/> <input type="checkbox"/>	108.00#	2171
	TFSZM7260	<input type="checkbox"/> <input type="checkbox"/> <input type="checkbox"/> <input type="checkbox"/>	<input type="checkbox"/>	<input type="checkbox"/> <input type="checkbox"/>	<input type="checkbox"/> <input type="checkbox"/> <input type="checkbox"/> <input type="checkbox"/> <input type="checkbox"/> <input type="checkbox"/>	<input type="checkbox"/> <input type="checkbox"/> <input type="checkbox"/> <input type="checkbox"/>	120.00#	2244
	TFSZM7860	<input type="checkbox"/> <input type="checkbox"/> <input type="checkbox"/> <input type="checkbox"/>	<input type="checkbox"/>	<input type="checkbox"/> <input type="checkbox"/>	<input type="checkbox"/> <input type="checkbox"/> <input type="checkbox"/> <input type="checkbox"/> <input type="checkbox"/> <input type="checkbox"/>	<input type="checkbox"/> <input type="checkbox"/> <input type="checkbox"/> <input type="checkbox"/>	128.00#	2267
	TFSZM8460	<input type="checkbox"/> <input type="checkbox"/> <input type="checkbox"/> <input type="checkbox"/>	<input type="checkbox"/>	<input type="checkbox"/> <input type="checkbox"/>	<input type="checkbox"/> <input type="checkbox"/> <input type="checkbox"/> <input type="checkbox"/> <input type="checkbox"/> <input type="checkbox"/>	<input type="checkbox"/> <input type="checkbox"/> <input type="checkbox"/> <input type="checkbox"/>	135.00#	2290
	TFSZM9060	<input type="checkbox"/> <input type="checkbox"/> <input type="checkbox"/> <input type="checkbox"/>	<input type="checkbox"/>	<input type="checkbox"/> <input type="checkbox"/>	<input type="checkbox"/> <input type="checkbox"/> <input type="checkbox"/> <input type="checkbox"/> <input type="checkbox"/> <input type="checkbox"/>	<input type="checkbox"/> <input type="checkbox"/> <input type="checkbox"/> <input type="checkbox"/>	143.00#	2310
	TFSZM9660	<input type="checkbox"/> <input type="checkbox"/> <input type="checkbox"/> <input type="checkbox"/>	<input type="checkbox"/>	<input type="checkbox"/> <input type="checkbox"/>	<input type="checkbox"/> <input type="checkbox"/> <input type="checkbox"/> <input type="checkbox"/> <input type="checkbox"/> <input type="checkbox"/>	<input type="checkbox"/> <input type="checkbox"/> <input type="checkbox"/> <input type="checkbox"/>	150.00#	2334

A **B** **C** **D** **E** **F**

HOW TO ORDER

- Indicate the following information on order form:
- Quantity of each item.
 - Model number, including options. See "How To Build a Model Number".
 - Any special service required.

Note:

- The indicates that a choice is required.
- The absence of the indicates that no choice is required.
- Alpha-numeric characters in place of indicate that no other alternatives are available.

HOW TO BUILD A MODEL NUMBER

- A** Select basic model.
- B** Select foot option.

FADJ	- Adjustable
FFLB	- Flat/Bridge
- C** Select top cap style.

F	- Flat aluminum top cap (standard)
N	- No top cap (specify for use with toppers)
- D** Select frame/trim color. Refer to the **Product Color Options** page in this price list.
- E** Select lower polyester felt color. Refer to the **Product Color Options** page in this price list.
- F** Select upper laminate. Refer to the **Product Color Options** page in this price list.

SPECIAL SERVICES

Special Carton Marking

With specially marked information N/C

Shipping

Ships **assembled, FOB Manitowoc, WI 54220, freight prepaid**. Freight class 70.

Specifications and prices are subject to change without prior notice.

Tattoo™ Flex Screens

Segmented Flex Screen with Polyester Felt Lower and Upper Core



Tattoo™ Flex Screens

Segmented Flex Screen with Polyester Felt Lower and Upper Core

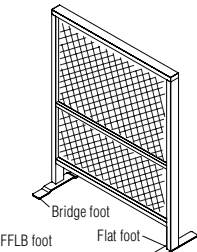
MODEL	MODEL NUMBER						Approx. Packaged Weight	Delivered Pricing	
	Basic Model	Foot Option	Top Cap Style	Frame/Trim Color	Lower Polyester Felt Color	Upper Polyester Felt Color			
 <p>FFLB foot option shown</p> <p>TFSZZ</p> <p>Segmented Flex Screen with Polyester Felt Lower and Upper Core - 48" H</p> <ul style="list-style-type: none"> Flex screen assembly includes aluminum powder-coated frame, core material, all trim, and feet Polyester felt is pinnable and non-magnetic Specify adjustable glide feet or non-adjustable flat/bridge feet Non-powered; no wire management Fully assembled; includes all trim Slotting under upper trim accepts screen-hung accessories Segmentation at 29" Elevated base does not accept power 	TFSZZ4248	<input type="checkbox"/>	<input type="checkbox"/>	<input type="checkbox"/>	<input type="checkbox"/>	<input type="checkbox"/>	54.00#	\$ 1470	
	TFSZZ4848	<input type="checkbox"/>	<input type="checkbox"/>	<input type="checkbox"/>	<input type="checkbox"/>	<input type="checkbox"/>	57.00#	1577	
	TFSZZ5448	<input type="checkbox"/>	<input type="checkbox"/>	<input type="checkbox"/>	<input type="checkbox"/>	<input type="checkbox"/>	61.00#	1728	
	TFSZZ6048	<input type="checkbox"/>	<input type="checkbox"/>	<input type="checkbox"/>	<input type="checkbox"/>	<input type="checkbox"/>	64.00#	2215	
	TFSZZ6648	<input type="checkbox"/>	<input type="checkbox"/>	<input type="checkbox"/>	<input type="checkbox"/>	<input type="checkbox"/>	67.00#	2288	
	TFSZZ7248	<input type="checkbox"/>	<input type="checkbox"/>	<input type="checkbox"/>	<input type="checkbox"/>	<input type="checkbox"/>	71.00#	2361	
	TFSZZ7848	<input type="checkbox"/>	<input type="checkbox"/>	<input type="checkbox"/>	<input type="checkbox"/>	<input type="checkbox"/>	75.00#	2380	
	TFSZZ8448	<input type="checkbox"/>	<input type="checkbox"/>	<input type="checkbox"/>	<input type="checkbox"/>	<input type="checkbox"/>	81.00#	2403	
	TFSZZ9048	<input type="checkbox"/>	<input type="checkbox"/>	<input type="checkbox"/>	<input type="checkbox"/>	<input type="checkbox"/>	82.00#	2422	
	TFSZZ9648	<input type="checkbox"/>	<input type="checkbox"/>	<input type="checkbox"/>	<input type="checkbox"/>	<input type="checkbox"/>	85.00#	2444	
TFSZZ	<p>Segmented Flex Screen with Polyester Felt Lower and Upper Core - 54" H</p> <ul style="list-style-type: none"> Flex screen assembly includes aluminum powder-coated frame, core material, all trim, and feet Polyester felt is pinnable and non-magnetic Specify adjustable glide feet or non-adjustable flat/bridge feet Non-powered; no wire management Fully assembled; includes all trim Slotting under upper trim accepts screen-hung accessories Segmentation at 29" Elevated base does not accept power 	TFSZZ4254	<input type="checkbox"/>	<input type="checkbox"/>	<input type="checkbox"/>	<input type="checkbox"/>	<input type="checkbox"/>	57.00#	\$ 1589
		TFSZZ4854	<input type="checkbox"/>	<input type="checkbox"/>	<input type="checkbox"/>	<input type="checkbox"/>	<input type="checkbox"/>	61.00#	1698
		TFSZZ5454	<input type="checkbox"/>	<input type="checkbox"/>	<input type="checkbox"/>	<input type="checkbox"/>	<input type="checkbox"/>	65.00#	1772
		TFSZZ6054	<input type="checkbox"/>	<input type="checkbox"/>	<input type="checkbox"/>	<input type="checkbox"/>	<input type="checkbox"/>	69.00#	2258
		TFSZZ6654	<input type="checkbox"/>	<input type="checkbox"/>	<input type="checkbox"/>	<input type="checkbox"/>	<input type="checkbox"/>	73.00#	2332
		TFSZZ7254	<input type="checkbox"/>	<input type="checkbox"/>	<input type="checkbox"/>	<input type="checkbox"/>	<input type="checkbox"/>	77.00#	2405
		TFSZZ7854	<input type="checkbox"/>	<input type="checkbox"/>	<input type="checkbox"/>	<input type="checkbox"/>	<input type="checkbox"/>	81.00#	2427
		TFSZZ8454	<input type="checkbox"/>	<input type="checkbox"/>	<input type="checkbox"/>	<input type="checkbox"/>	<input type="checkbox"/>	85.00#	2450
		TFSZZ9054	<input type="checkbox"/>	<input type="checkbox"/>	<input type="checkbox"/>	<input type="checkbox"/>	<input type="checkbox"/>	89.00#	2471
		TFSZZ9654	<input type="checkbox"/>	<input type="checkbox"/>	<input type="checkbox"/>	<input type="checkbox"/>	<input type="checkbox"/>	93.00#	2493

A **B** **C** **D** **E** **F**

HOW TO ORDER

- Indicate the following information on order form:
- Quantity of each item.
 - Model number, including options. See "How To Build a Model Number".
 - Any special service required.

Note:

- The indicates that a choice is required.
- The absence of the indicates that no choice is required.
- Alpha-numeric characters in place of indicate that no other alternatives are available.

HOW TO BUILD A MODEL NUMBER

- A** Select basic model.
- B** Select foot option.

FADJ	- Adjustable
FFLB	- Flat/Bridge
- C** Select top cap style.

F	- Flat aluminum top cap (standard)
N	- No top cap (specify for use with toppers)
- D** Select frame/trim color. Refer to the **Product Color Options** page in this price list.
- E** Select lower polyester felt color. Refer to the **Product Color Options** page in this price list.
- F** Select upper polyester felt color. Refer to the **Product Color Options** page in this price list.

SPECIAL SERVICES

Special Carton Marking

With specially marked information N/C

Shipping

Ships assembled, FOB Manitowoc, WI 54220, freight prepaid. Freight class 70.

Specifications and prices are subject to change without prior notice.

Tattoo™ Flex Screens

Segmented Flex Screen with Polyester Felt Lower and Upper Core



Tattoo™ Flex Screens

Segmented Flex Screen with Polyester Felt Lower and Upper Core

MODEL	MODEL NUMBER						Approx. Packaged Weight	Delivered Pricing
	Basic Model	Foot Option	Top Cap Style	Frame/Trim Color	Lower Polyester Felt Color	Upper Polyester Felt Color		
TFSZZ Segmented Flex Screen with Polyester Felt Lower and Upper Core - 60" H • Flex screen assembly includes aluminum powder-coated frame, core material, all trim, and feet • Polyester felt is pinnable and non-magnetic • Specify adjustable glide feet or non-adjustable flat/bridge feet • Non-powered; no wire management • Fully assembled; includes all trim • Slotting under upper trim accepts screen-hung accessories • Segmentation at 29" • Elevated base does not accept power	TFSZZ4260	<input type="checkbox"/>	<input type="checkbox"/>	<input type="checkbox"/>	<input type="checkbox"/>	<input type="checkbox"/>	61.00#	\$ 1828
	TFSZZ4860	<input type="checkbox"/>	<input type="checkbox"/>	<input type="checkbox"/>	<input type="checkbox"/>	<input type="checkbox"/>	65.00#	1914
	TFSZZ5460	<input type="checkbox"/>	<input type="checkbox"/>	<input type="checkbox"/>	<input type="checkbox"/>	<input type="checkbox"/>	70.00#	2127
	TFSZZ6060	<input type="checkbox"/>	<input type="checkbox"/>	<input type="checkbox"/>	<input type="checkbox"/>	<input type="checkbox"/>	74.00#	2796
	TFSZZ6660	<input type="checkbox"/>	<input type="checkbox"/>	<input type="checkbox"/>	<input type="checkbox"/>	<input type="checkbox"/>	79.00#	2872
	TFSZZ7260	<input type="checkbox"/>	<input type="checkbox"/>	<input type="checkbox"/>	<input type="checkbox"/>	<input type="checkbox"/>	83.00#	2946
	TFSZZ7860	<input type="checkbox"/>	<input type="checkbox"/>	<input type="checkbox"/>	<input type="checkbox"/>	<input type="checkbox"/>	88.00#	2968
	TFSZZ8460	<input type="checkbox"/>	<input type="checkbox"/>	<input type="checkbox"/>	<input type="checkbox"/>	<input type="checkbox"/>	92.00#	2991
	TFSZZ9060	<input type="checkbox"/>	<input type="checkbox"/>	<input type="checkbox"/>	<input type="checkbox"/>	<input type="checkbox"/>	97.00#	3012
	TFSZZ9660	<input type="checkbox"/>	<input type="checkbox"/>	<input type="checkbox"/>	<input type="checkbox"/>	<input type="checkbox"/>	101.00#	3035

A **B** **C** **D** **E** **F**

HOW TO ORDER

- Indicate the following information on order form:
- Quantity of each item.
 - Model number, including options. See "How To Build a Model Number".
 - Any special service required.

Note:

- The indicates that a choice is required.
- The absence of the indicates that no choice is required.
- Alpha-numeric characters in place of indicate that no other alternatives are available.

HOW TO BUILD A MODEL NUMBER

- A** Select basic model.
- B** Select foot option.

FADJ	- Adjustable
FFLB	- Flat/Bridge
- C** Select top cap style.

F	- Flat aluminum top cap (standard)
N	- No top cap (specify for use with toppers)
- D** Select frame/trim color. Refer to the **Product Color Options** page in this price list.
- E** Select lower polyester felt color. Refer to the **Product Color Options** page in this price list.
- F** Select upper polyester felt color. Refer to the **Product Color Options** page in this price list.

SPECIAL SERVICES

Special Carton Marking

With specially marked information N/C

Shipping

Ships **assembled, FOB Manitowoc, WI 54220, freight prepaid.** Freight class 70.

Specifications and prices are subject to change without prior notice.

Tattoo™ Flex Screens

Segmented Flex Screen with Polyester Felt Lower, Fabric Upper Core



Tattoo™ Flex Screens

Segmented Flex Screen with Polyester Felt Lower, Fabric Upper Core

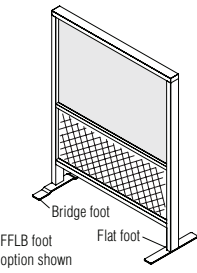
MODEL	MODEL NUMBER						Approx. Packaged Weight	Delivered Pricing Fabric Grade 1 & C.O.M.	Delivered Pricing Fabric Grade 2	Delivered Pricing Fabric Grade 3 & Pallas Vertical Fabric Grade PV	Delivered Pricing Pallas Vertical Fabric Grade PV1	Delivered Pricing Pallas Vertical Fabric Grade PV2	
	Basic Model	Foot Option	Top Cap Style	Frame/Trim Color	Lower Polyester Felt Color	Upper Fabric Color							
 <p>FFLB foot option shown</p> <p>TFSZF</p> <p>Segmented Flex Screen with Polyester Felt Lower, Fabric Upper Core - 48" H</p> <ul style="list-style-type: none"> Flex screen assembly includes aluminum powder-coated frame, core material, all trim, and feet Upper segment features identical tackable fabric core on both sides, fabric pattern is railroaded Polyester felt is pinnable and non-magnetic Specify adjustable glide feet or non-adjustable flat/bridge feet Non-powered; no wire management Fully assembled; includes all trim Slotting under upper trim accepts screen-hung accessories Segmentation at 29" Elevated base does not accept power 	TFSZF4248	<input type="checkbox"/>	<input type="checkbox"/>	<input type="checkbox"/>	<input type="checkbox"/>	<input type="checkbox"/>	54.00#	\$ 1580	\$ 1613	\$ 1645	\$ 1659	\$ 1723	
	TFSZF4848	<input type="checkbox"/>	<input type="checkbox"/>	<input type="checkbox"/>	<input type="checkbox"/>	<input type="checkbox"/>	57.00#	1662	1695	1729	1744	1810	
	TFSZF5448	<input type="checkbox"/>	<input type="checkbox"/>	<input type="checkbox"/>	<input type="checkbox"/>	<input type="checkbox"/>	61.00#	1734	1767	1805	1821	1891	
	TFSZF6048	<input type="checkbox"/>	<input type="checkbox"/>	<input type="checkbox"/>	<input type="checkbox"/>	<input type="checkbox"/>	64.00#	2059	2101	2140	2161	2244	
	TFSZF6648	<input type="checkbox"/>	<input type="checkbox"/>	<input type="checkbox"/>	<input type="checkbox"/>	<input type="checkbox"/>	67.00#	2188	2230	2274	2297	2383	
	TFSZF7248	<input type="checkbox"/>	<input type="checkbox"/>	<input type="checkbox"/>	<input type="checkbox"/>	<input type="checkbox"/>	71.00#	2260	2304	2350	2373	2463	
	TFSZF7848	<input type="checkbox"/>	<input type="checkbox"/>	<input type="checkbox"/>	<input type="checkbox"/>	<input type="checkbox"/>	75.00#	2324	2372	2418	2440	2535	
	TFSZF8448	<input type="checkbox"/>	<input type="checkbox"/>	<input type="checkbox"/>	<input type="checkbox"/>	<input type="checkbox"/>	81.00#	2352	2398	2445	2468	2563	
	TFSZF9048	<input type="checkbox"/>	<input type="checkbox"/>	<input type="checkbox"/>	<input type="checkbox"/>	<input type="checkbox"/>	82.00#	2417	2465	2515	2537	2634	
	TFSZF9648	<input type="checkbox"/>	<input type="checkbox"/>	<input type="checkbox"/>	<input type="checkbox"/>	<input type="checkbox"/>	85.00#	2438	2487	2536	2561	2658	
TFSZF	<p>Segmented Flex Screen with Polyester Felt Lower, Fabric Upper Core - 54" H</p> <ul style="list-style-type: none"> Flex screen assembly includes aluminum powder-coated frame, core material, all trim, and feet Upper segment features identical tackable fabric core on both sides, fabric pattern is railroaded Polyester felt is pinnable and non-magnetic Specify adjustable glide feet or non-adjustable flat/bridge feet Non-powered; no wire management Fully assembled; includes all trim Slotting under upper trim accepts screen-hung accessories Segmentation at 29" Elevated base does not accept power 	TFSZF4254	<input type="checkbox"/>	<input type="checkbox"/>	<input type="checkbox"/>	<input type="checkbox"/>	<input type="checkbox"/>	57.00#	\$ 1612	\$ 1644	\$ 1676	\$ 1692	\$ 1756
		TFSZF4854	<input type="checkbox"/>	<input type="checkbox"/>	<input type="checkbox"/>	<input type="checkbox"/>	<input type="checkbox"/>	61.00#	1706	1739	1774	1791	1859
		TFSZF5454	<input type="checkbox"/>	<input type="checkbox"/>	<input type="checkbox"/>	<input type="checkbox"/>	<input type="checkbox"/>	65.00#	1778	1814	1848	1867	1938
		TFSZF6054	<input type="checkbox"/>	<input type="checkbox"/>	<input type="checkbox"/>	<input type="checkbox"/>	<input type="checkbox"/>	69.00#	2104	2145	2188	2208	2292
		TFSZF6654	<input type="checkbox"/>	<input type="checkbox"/>	<input type="checkbox"/>	<input type="checkbox"/>	<input type="checkbox"/>	73.00#	2232	2276	2321	2345	2433
		TFSZF7254	<input type="checkbox"/>	<input type="checkbox"/>	<input type="checkbox"/>	<input type="checkbox"/>	<input type="checkbox"/>	77.00#	2304	2351	2397	2420	2514
		TFSZF7854	<input type="checkbox"/>	<input type="checkbox"/>	<input type="checkbox"/>	<input type="checkbox"/>	<input type="checkbox"/>	81.00#	2372	2418	2465	2490	2586
		TFSZF8454	<input type="checkbox"/>	<input type="checkbox"/>	<input type="checkbox"/>	<input type="checkbox"/>	<input type="checkbox"/>	85.00#	2398	2447	2494	2518	2615
		TFSZF9054	<input type="checkbox"/>	<input type="checkbox"/>	<input type="checkbox"/>	<input type="checkbox"/>	<input type="checkbox"/>	89.00#	2464	2515	2563	2588	2686
		TFSZF9654	<input type="checkbox"/>	<input type="checkbox"/>	<input type="checkbox"/>	<input type="checkbox"/>	<input type="checkbox"/>	93.00#	2487	2536	2587	2610	2710

A **B** **C** **D** **E** **F**

HOW TO ORDER

- Indicate the following information on order form:
- Quantity of each item.
 - Model number, including options. See "How To Build a Model Number".
 - Any special service required.

Note: • The indicates that a choice is required.

- The absence of the indicates that no choice is required.
- Alpha-numeric characters in place of indicate that no other alternatives are available.

HOW TO BUILD A MODEL NUMBER

- A** Select basic model.
- B** Select foot option.

FADJ	- Adjustable
FFLB	- Flat/Bridge
- C** Select top cap style.

F	- Flat aluminum top cap (standard)
N	- No top cap (specify for use with toppers)
- D** Select frame/trim color. Refer to the **Product Color Options** page in this price list.
- E** Select lower polyester felt color. Refer to the **Product Color Options** page in this price list.
- F** Select upper fabric color. Refer to ki.com/fabrics

INFORMATION

COM YARDAGE REQUIREMENTS

Screen Width/Length	Fabric Required
42	2.556
48	2.889
54	3.222
60	3.556
66	3.889
72	4.222
78	4.556
84	4.889
90	5.222
96	5.556

SPECIAL SERVICES

Special Carton Marking

With specially marked information N/C

Shipping

Ships assembled, FOB Manitowoc, WI 54220, freight prepaid. Freight class 70.

Specifications and prices are subject to change without prior notice.

Tattoo™ Flex Screens

Segmented Flex Screen with Polyester Felt Lower, Fabric Upper Core



Tattoo™ Flex Screens

Segmented Flex Screen with Polyester Felt Lower, Fabric Upper Core

MODEL	MODEL NUMBER						Approx. Packaged Weight	Delivered Pricing Fabric Grade 1 & C.O.M.	Delivered Pricing Fabric Grade 2	Delivered Pricing Fabric Grade 3 & Pallas Vertical Fabric Grade PV	Delivered Pricing Pallas Vertical Fabric Grade PV1	Delivered Pricing Pallas Vertical Fabric Grade PV2
	Basic Model	Foot Option	Top Cap Style	Frame/Trim Color	Lower Polyester Felt Color	Upper Fabric Color						
TFSZF Segmented Flex Screen with Polyester Felt Lower, Fabric Upper Core - 60" H <ul style="list-style-type: none"> Flex screen assembly includes aluminum powder-coated frame, core material, all trim, and feet Upper segment features identical tackable fabric core on both sides, fabric pattern is railroaded Polyester felt is pinnable and non-magnetic Specify adjustable glide feet or non-adjustable flat/bridge feet Non-powered; no wire management Fully assembled; includes all trim Slotting under upper trim accepts screen-hung accessories Segmentation at 29" Elevated base does not accept power 	TFSZF4260	<input type="checkbox"/> <input type="checkbox"/> <input type="checkbox"/> <input type="checkbox"/>	<input type="checkbox"/>	<input type="checkbox"/> <input type="checkbox"/>	<input type="checkbox"/> <input type="checkbox"/> <input type="checkbox"/> <input type="checkbox"/> <input type="checkbox"/> <input type="checkbox"/>	<input type="checkbox"/> <input type="checkbox"/> <input type="checkbox"/> <input type="checkbox"/> <input type="checkbox"/> <input type="checkbox"/>	61.00#	\$ 1821	\$ 1859	\$ 1894	\$ 1913	\$ 1986
	TFSZF4860	<input type="checkbox"/> <input type="checkbox"/> <input type="checkbox"/> <input type="checkbox"/>	<input type="checkbox"/>	<input type="checkbox"/> <input type="checkbox"/>	<input type="checkbox"/> <input type="checkbox"/> <input type="checkbox"/> <input type="checkbox"/> <input type="checkbox"/> <input type="checkbox"/>	<input type="checkbox"/> <input type="checkbox"/> <input type="checkbox"/> <input type="checkbox"/> <input type="checkbox"/> <input type="checkbox"/>	65.00#	1902	1939	1977	1996	2073
	TFSZF5460	<input type="checkbox"/> <input type="checkbox"/> <input type="checkbox"/> <input type="checkbox"/>	<input type="checkbox"/>	<input type="checkbox"/> <input type="checkbox"/>	<input type="checkbox"/> <input type="checkbox"/> <input type="checkbox"/> <input type="checkbox"/> <input type="checkbox"/> <input type="checkbox"/>	<input type="checkbox"/> <input type="checkbox"/> <input type="checkbox"/> <input type="checkbox"/> <input type="checkbox"/> <input type="checkbox"/>	70.00#	1976	2014	2054	2075	2153
	TFSZF6060	<input type="checkbox"/> <input type="checkbox"/> <input type="checkbox"/> <input type="checkbox"/>	<input type="checkbox"/>	<input type="checkbox"/> <input type="checkbox"/>	<input type="checkbox"/> <input type="checkbox"/> <input type="checkbox"/> <input type="checkbox"/> <input type="checkbox"/> <input type="checkbox"/>	<input type="checkbox"/> <input type="checkbox"/> <input type="checkbox"/> <input type="checkbox"/> <input type="checkbox"/> <input type="checkbox"/>	74.00#	2301	2347	2392	2416	2508
	TFSZF6660	<input type="checkbox"/> <input type="checkbox"/> <input type="checkbox"/> <input type="checkbox"/>	<input type="checkbox"/>	<input type="checkbox"/> <input type="checkbox"/>	<input type="checkbox"/> <input type="checkbox"/> <input type="checkbox"/> <input type="checkbox"/> <input type="checkbox"/> <input type="checkbox"/>	<input type="checkbox"/> <input type="checkbox"/> <input type="checkbox"/> <input type="checkbox"/> <input type="checkbox"/> <input type="checkbox"/>	79.00#	2481	2532	2579	2604	2705
	TFSZF7260	<input type="checkbox"/> <input type="checkbox"/> <input type="checkbox"/> <input type="checkbox"/>	<input type="checkbox"/>	<input type="checkbox"/> <input type="checkbox"/>	<input type="checkbox"/> <input type="checkbox"/> <input type="checkbox"/> <input type="checkbox"/> <input type="checkbox"/> <input type="checkbox"/>	<input type="checkbox"/> <input type="checkbox"/> <input type="checkbox"/> <input type="checkbox"/> <input type="checkbox"/> <input type="checkbox"/>	83.00#	2554	2605	2656	2681	2784
	TFSZF7860	<input type="checkbox"/> <input type="checkbox"/> <input type="checkbox"/> <input type="checkbox"/>	<input type="checkbox"/>	<input type="checkbox"/> <input type="checkbox"/>	<input type="checkbox"/> <input type="checkbox"/> <input type="checkbox"/> <input type="checkbox"/> <input type="checkbox"/> <input type="checkbox"/>	<input type="checkbox"/> <input type="checkbox"/> <input type="checkbox"/> <input type="checkbox"/> <input type="checkbox"/> <input type="checkbox"/>	88.00#	2621	2675	2727	2752	2859
	TFSZF8460	<input type="checkbox"/> <input type="checkbox"/> <input type="checkbox"/> <input type="checkbox"/>	<input type="checkbox"/>	<input type="checkbox"/> <input type="checkbox"/>	<input type="checkbox"/> <input type="checkbox"/> <input type="checkbox"/> <input type="checkbox"/> <input type="checkbox"/> <input type="checkbox"/>	<input type="checkbox"/> <input type="checkbox"/> <input type="checkbox"/> <input type="checkbox"/> <input type="checkbox"/> <input type="checkbox"/>	92.00#	2650	2702	2755	2782	2889
	TFSZF9060	<input type="checkbox"/> <input type="checkbox"/> <input type="checkbox"/> <input type="checkbox"/>	<input type="checkbox"/>	<input type="checkbox"/> <input type="checkbox"/>	<input type="checkbox"/> <input type="checkbox"/> <input type="checkbox"/> <input type="checkbox"/> <input type="checkbox"/> <input type="checkbox"/>	<input type="checkbox"/> <input type="checkbox"/> <input type="checkbox"/> <input type="checkbox"/> <input type="checkbox"/> <input type="checkbox"/>	97.00#	2716	2772	2825	2852	2960
	TFSZF9660	<input type="checkbox"/> <input type="checkbox"/> <input type="checkbox"/> <input type="checkbox"/>	<input type="checkbox"/>	<input type="checkbox"/> <input type="checkbox"/>	<input type="checkbox"/> <input type="checkbox"/> <input type="checkbox"/> <input type="checkbox"/> <input type="checkbox"/> <input type="checkbox"/>	<input type="checkbox"/> <input type="checkbox"/> <input type="checkbox"/> <input type="checkbox"/> <input type="checkbox"/> <input type="checkbox"/>	101.00#	2739	2794	2848	2876	2985

A **B** **C** **D** **E** **F**

HOW TO ORDER

- Indicate the following information on order form:
- Quantity of each item.
 - Model number, including options. See "How To Build a Model Number".
 - Any special service required.

Note:

- The indicates that a choice is required.
- The absence of the indicates that no choice is required.
- Alpha-numeric characters in place of indicate that no other alternatives are available.

HOW TO BUILD A MODEL NUMBER

- A** Select basic model.
- B** Select foot option.

FADJ	- Adjustable
FFLB	- Flat/Bridge
- C** Select top cap style.

F	- Flat aluminum top cap (standard)
N	- No top cap (specify for use with toppers)
- D** Select frame/trim color. Refer to the **Product Color Options** page in this price list.
- E** Select lower polyester felt color. Refer to the **Product Color Options** page in this price list.
- F** Select upper fabric color. Refer to ki.com/fabrics

INFORMATION

COM YARDAGE REQUIREMENTS	
Screen Width/Length	Fabric Required
42	2.556
48	2.889
54	3.222
60	3.556
66	3.889
72	4.222
78	4.556
84	4.889
90	5.222
96	5.556

SPECIAL SERVICES

Special Carton Marking

With specially marked information N/C

Shipping
 Ships **assembled, FOB Manitowoc, WI 54220, freight prepaid.** Freight class 70.

Specifications and prices are subject to change without prior notice.

Tattoo™ Flex Screens

Segmented Flex Screen with Polyester Felt Lower, Fluted Polycarbonate Upper Core



Tattoo™ Flex Screens

Segmented Flex Screen with Polyester Felt Lower, Fluted Polycarbonate Upper Core

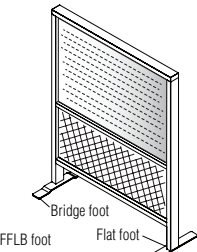
MODEL	MODEL NUMBER					Approx. Packaged Weight	Delivered Pricing
	Basic Model	Foot Option	Top Cap Style	Frame/Trim Color	Lower Polyester Felt Color		
 <p>FFLB foot option shown</p> <p>TFSZP</p> <p>Segmented Flex Screen with Polyester Felt Lower, Fluted Polycarbonate Upper Core - 48" H</p> <ul style="list-style-type: none"> Flex screen assembly includes aluminum powder-coated frame, core material, all trim, and feet Non-magnetic fluted polycarbonate upper segment Polyester felt is pinnable and non-magnetic Specify adjustable glide feet or non-adjustable flat/bridge feet Non-powered; no wire management Fully assembled; includes all trim Slotting under upper trim accepts screen-hung accessories Segmentation at 29" Elevated base does not accept power Fluting runs horizontal 	TFSZP4248	<input type="checkbox"/>	<input type="checkbox"/>	<input type="checkbox"/>	<input type="checkbox"/>	54.00#	\$ 1544
	TFSZP4848	<input type="checkbox"/>	<input type="checkbox"/>	<input type="checkbox"/>	<input type="checkbox"/>	57.00#	1649
	TFSZP5448	<input type="checkbox"/>	<input type="checkbox"/>	<input type="checkbox"/>	<input type="checkbox"/>	61.00#	1749
	TFSZP6048	<input type="checkbox"/>	<input type="checkbox"/>	<input type="checkbox"/>	<input type="checkbox"/>	64.00#	2054
	TFSZP6648	<input type="checkbox"/>	<input type="checkbox"/>	<input type="checkbox"/>	<input type="checkbox"/>	67.00#	2154
	TFSZP7248	<input type="checkbox"/>	<input type="checkbox"/>	<input type="checkbox"/>	<input type="checkbox"/>	71.00#	2253
	TFSZP7848	<input type="checkbox"/>	<input type="checkbox"/>	<input type="checkbox"/>	<input type="checkbox"/>	75.00#	2301
	TFSZP8448	<input type="checkbox"/>	<input type="checkbox"/>	<input type="checkbox"/>	<input type="checkbox"/>	81.00#	2348
	TFSZP9048	<input type="checkbox"/>	<input type="checkbox"/>	<input type="checkbox"/>	<input type="checkbox"/>	82.00#	2396
	TFSZP9648	<input type="checkbox"/>	<input type="checkbox"/>	<input type="checkbox"/>	<input type="checkbox"/>	85.00#	2443
TFSZP	TFSZP4254	<input type="checkbox"/>	<input type="checkbox"/>	<input type="checkbox"/>	<input type="checkbox"/>	57.00#	\$ 1598
	TFSZP4854	<input type="checkbox"/>	<input type="checkbox"/>	<input type="checkbox"/>	<input type="checkbox"/>	61.00#	1694
	TFSZP5454	<input type="checkbox"/>	<input type="checkbox"/>	<input type="checkbox"/>	<input type="checkbox"/>	65.00#	1792
	TFSZP6054	<input type="checkbox"/>	<input type="checkbox"/>	<input type="checkbox"/>	<input type="checkbox"/>	69.00#	2100
	TFSZP6654	<input type="checkbox"/>	<input type="checkbox"/>	<input type="checkbox"/>	<input type="checkbox"/>	73.00#	2200
	TFSZP7254	<input type="checkbox"/>	<input type="checkbox"/>	<input type="checkbox"/>	<input type="checkbox"/>	77.00#	2298
	TFSZP7854	<input type="checkbox"/>	<input type="checkbox"/>	<input type="checkbox"/>	<input type="checkbox"/>	81.00#	2347
	TFSZP8454	<input type="checkbox"/>	<input type="checkbox"/>	<input type="checkbox"/>	<input type="checkbox"/>	85.00#	2394
	TFSZP9054	<input type="checkbox"/>	<input type="checkbox"/>	<input type="checkbox"/>	<input type="checkbox"/>	89.00#	2443
	TFSZP9654	<input type="checkbox"/>	<input type="checkbox"/>	<input type="checkbox"/>	<input type="checkbox"/>	93.00#	2492

A **B** **C** **D** **E**

HOW TO ORDER

- Indicate the following information on order form:
- Quantity of each item.
 - Model number, including options. See "How To Build a Model Number".
 - Any special service required.

Note:

- The indicates that a choice is required.
- The absence of the indicates that no choice is required.
- Alpha-numeric characters in place of indicate that no other alternatives are available.

HOW TO BUILD A MODEL NUMBER

- A** Select basic model.
- B** Select foot option.
 - FADJ - Adjustable
 - FFLB - Flat/Bridge
- C** Select top cap style.
 - F - Flat aluminum top cap (standard)
 - N - No top cap (specify for use with toppers)
- D** Select frame/trim color. Refer to the **Product Color Options** page in this price list.
- E** Select lower polyester felt color. Refer to the **Product Color Options** page in this price list.

SPECIAL SERVICES

Special Carton Marking

With specially marked information N/C

Shipping

Ships assembled, FOB Manitowoc, WI 54220, freight prepaid. Freight class 70.

Specifications and prices are subject to change without prior notice.

Tattoo™ Flex Screens

Segmented Flex Screen with Polyester Felt Lower, Fluted Polycarbonate Upper Core



Tattoo™ Flex Screens

Segmented Flex Screen with Polyester Felt Lower, Fluted Polycarbonate Upper Core

MODEL	MODEL NUMBER					Approx. Packaged Weight	Delivered Pricing
	Basic Model	Foot Option	Top Cap Style	Frame/Trim Color	Lower Polyester Felt Color		
TFSZP Segmented Flex Screen with Polyester Felt Lower, Fluted Polycarbonate Upper Core - 60" H <ul style="list-style-type: none"> Flex screen assembly includes aluminum powder-coated frame, core material, all trim, and feet Non-magnetic fluted polycarbonate upper segment Polyester felt is pinnable and non-magnetic Specify adjustable glide feet or non-adjustable flat/bridge feet Non-powered; no wire management Fully assembled; includes all trim Slotting under upper trim accepts screen-hung accessories Segmentation at 29" Elevated base does not accept power Fluting runs horizontal 	TFSZP4260	<input type="checkbox"/>	<input type="checkbox"/>	<input type="checkbox"/>	<input type="checkbox"/>	61.00#	\$ 1706
	TFSZP4860	<input type="checkbox"/>	<input type="checkbox"/>	<input type="checkbox"/>	<input type="checkbox"/>	65.00#	1839
	TFSZP5460	<input type="checkbox"/>	<input type="checkbox"/>	<input type="checkbox"/>	<input type="checkbox"/>	70.00#	1939
	TFSZP6060	<input type="checkbox"/>	<input type="checkbox"/>	<input type="checkbox"/>	<input type="checkbox"/>	74.00#	2247
	TFSZP6660	<input type="checkbox"/>	<input type="checkbox"/>	<input type="checkbox"/>	<input type="checkbox"/>	79.00#	2348
	TFSZP7260	<input type="checkbox"/>	<input type="checkbox"/>	<input type="checkbox"/>	<input type="checkbox"/>	83.00#	2448
	TFSZP7860	<input type="checkbox"/>	<input type="checkbox"/>	<input type="checkbox"/>	<input type="checkbox"/>	88.00#	2496
	TFSZP8460	<input type="checkbox"/>	<input type="checkbox"/>	<input type="checkbox"/>	<input type="checkbox"/>	92.00#	2546
	TFSZP9060	<input type="checkbox"/>	<input type="checkbox"/>	<input type="checkbox"/>	<input type="checkbox"/>	97.00#	2594
	TFSZP9660	<input type="checkbox"/>	<input type="checkbox"/>	<input type="checkbox"/>	<input type="checkbox"/>	101.00#	2644
	A	B	C	D	E		

HOW TO ORDER

Indicate the following information on order form:

- Quantity of each item.
- Model number, including options. See "How To Build a Model Number".
- Any special service required.

Note: • The indicates that a choice is required.

- The absence of the indicates that no choice is required.
- Alpha-numeric characters in place of indicate that no other alternatives are available.

HOW TO BUILD A MODEL NUMBER

- A** Select basic model.
- B** Select foot option.
FADJ - Adjustable
FFLB - Flat/Bridge
- C** Select top cap style.
F - Flat aluminum top cap (standard)
N - No top cap (specify for use with toppers)
- D** Select frame/trim color.
Refer to the **Product Color Options** page in this price list.
- E** Select lower polyester felt color.
Refer to the **Product Color Options** page in this price list.

SPECIAL SERVICES

Special Carton Marking

With specially marked information N/C

Shipping

Ships **assembled, FOB Manitowoc, WI 54220, freight prepaid**. Freight class 70.

Specifications and prices are subject to change without prior notice.

Tattoo™ Flex Screens

Segmented Flex Screen with Polyester Felt Lower, Acrylic Upper Core



Tattoo™ Flex Screens

Segmented Flex Screen with Polyester Felt Lower, Acrylic Upper Core

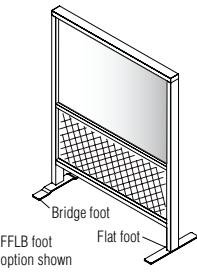
MODEL	MODEL NUMBER						Approx. Packaged Weight	Delivered Pricing	
	Basic Model	Foot Option	Top Cap Style	Frame/Trim Color	Lower Polyester Felt Color	Upper Acrylic Finish			
 <p>FFLB foot option shown</p> <p>TFSZA</p> <p>Segmented Flex Screen with Polyester Felt Lower, Acrylic Upper Core - 48" H</p> <ul style="list-style-type: none"> Flex screen assembly includes aluminum powder-coated frame, core material, all trim, and feet Non-magnetic acrylic core upper Polyester felt is pinnable and non-magnetic Specify adjustable glide feet or non-adjustable flat/bridge feet Non-powered; no wire management Fully assembled; includes all trim Slotting under upper trim accepts screen-hung accessories Segmentation at 29" Elevated base does not accept power 	TFSZA4248	<input type="checkbox"/>	<input type="checkbox"/>	<input type="checkbox"/>	<input type="checkbox"/>	<input type="checkbox"/>	72.00#	\$ 1643	
	TFSZA4848	<input type="checkbox"/>	<input type="checkbox"/>	<input type="checkbox"/>	<input type="checkbox"/>	<input type="checkbox"/>	78.00#	1750	
	TFSZA5448	<input type="checkbox"/>	<input type="checkbox"/>	<input type="checkbox"/>	<input type="checkbox"/>	<input type="checkbox"/>	84.00#	1862	
	TFSZA6048	<input type="checkbox"/>	<input type="checkbox"/>	<input type="checkbox"/>	<input type="checkbox"/>	<input type="checkbox"/>	90.00#	2142	
	TFSZA6648	<input type="checkbox"/>	<input type="checkbox"/>	<input type="checkbox"/>	<input type="checkbox"/>	<input type="checkbox"/>	96.00#	2266	
	TFSZA7248	<input type="checkbox"/>	<input type="checkbox"/>	<input type="checkbox"/>	<input type="checkbox"/>	<input type="checkbox"/>	102.00#	2406	
	TFSZA7848	<input type="checkbox"/>	<input type="checkbox"/>	<input type="checkbox"/>	<input type="checkbox"/>	<input type="checkbox"/>	108.00#	2429	
	TFSZA8448	<input type="checkbox"/>	<input type="checkbox"/>	<input type="checkbox"/>	<input type="checkbox"/>	<input type="checkbox"/>	114.00#	2684	
	TFSZA9048	<input type="checkbox"/>	<input type="checkbox"/>	<input type="checkbox"/>	<input type="checkbox"/>	<input type="checkbox"/>	120.00#	2708	
	TFSZA9648	<input type="checkbox"/>	<input type="checkbox"/>	<input type="checkbox"/>	<input type="checkbox"/>	<input type="checkbox"/>	126.00#	2731	
TFSZA									
	<p>Segmented Flex Screen with Polyester Felt Lower, Acrylic Upper Core - 54" H</p> <ul style="list-style-type: none"> Flex screen assembly includes aluminum powder-coated frame, core material, all trim, and feet Non-magnetic acrylic core upper Polyester felt is pinnable and non-magnetic Specify adjustable glide feet or non-adjustable flat/bridge feet Non-powered; no wire management Fully assembled; includes all trim Slotting under upper trim accepts screen-hung accessories Segmentation at 29" Elevated base does not accept power 	TFSZA4254	<input type="checkbox"/>	<input type="checkbox"/>	<input type="checkbox"/>	<input type="checkbox"/>	<input type="checkbox"/>	78.00#	\$ 1774
		TFSZA4854	<input type="checkbox"/>	<input type="checkbox"/>	<input type="checkbox"/>	<input type="checkbox"/>	<input type="checkbox"/>	84.00#	1904
		TFSZA5454	<input type="checkbox"/>	<input type="checkbox"/>	<input type="checkbox"/>	<input type="checkbox"/>	<input type="checkbox"/>	91.00#	2046
		TFSZA6054	<input type="checkbox"/>	<input type="checkbox"/>	<input type="checkbox"/>	<input type="checkbox"/>	<input type="checkbox"/>	98.00#	2329
		TFSZA6654	<input type="checkbox"/>	<input type="checkbox"/>	<input type="checkbox"/>	<input type="checkbox"/>	<input type="checkbox"/>	100.00#	2497
		TFSZA7254	<input type="checkbox"/>	<input type="checkbox"/>	<input type="checkbox"/>	<input type="checkbox"/>	<input type="checkbox"/>	111.00#	2572
		TFSZA7854	<input type="checkbox"/>	<input type="checkbox"/>	<input type="checkbox"/>	<input type="checkbox"/>	<input type="checkbox"/>	118.00#	2740
		TFSZA8454	<input type="checkbox"/>	<input type="checkbox"/>	<input type="checkbox"/>	<input type="checkbox"/>	<input type="checkbox"/>	125.00#	3005
		TFSZA9054	<input type="checkbox"/>	<input type="checkbox"/>	<input type="checkbox"/>	<input type="checkbox"/>	<input type="checkbox"/>	132.00#	3029
TFSZA9654		<input type="checkbox"/>	<input type="checkbox"/>	<input type="checkbox"/>	<input type="checkbox"/>	<input type="checkbox"/>	138.00#	3053	

A **B** **C** **D** **E** **F**

HOW TO ORDER

- Indicate the following information on order form:
- Quantity of each item.
 - Model number, including options. See "How To Build a Model Number".
 - Any special service required.

Note:

- The indicates that a choice is required.
- The absence of the indicates that no choice is required.
- Alpha-numeric characters in place of indicate that no other alternatives are available.

HOW TO BUILD A MODEL NUMBER

- A** Select basic model.
- B** Select foot option.

FADJ	- Adjustable
FFLB	- Flat/Bridge
- C** Select top cap style.

F	- Flat aluminum top cap (standard)
N	- No top cap (specify for use with toppers)
- D** Select frame/trim color. Refer to the **Product Color Options** page in this price list.
- E** Select lower polyester felt color. Refer to the **Product Color Options** page in this price list.
- F** Select upper acrylic finish. Refer to the **Product Color Options** page in this price list.

SPECIAL SERVICES

Special Carton Marking

With specially marked information N/C

Shipping

Ships **assembled, FOB Manitowoc, WI 54220, freight prepaid.** Freight class 70.

Specifications and prices are subject to change without prior notice.

Tattoo™ Flex Screens

Segmented Flex Screen with Polyester Felt Lower, Acrylic Upper Core



Tattoo™ Flex Screens

Segmented Flex Screen with Polyester Felt Lower, Acrylic Upper Core

MODEL	MODEL NUMBER						Approx. Packaged Weight	Delivered Pricing
	Basic Model	Foot Option	Top Cap Style	Frame/Trim Color	Lower Polyester Felt Color	Upper Acrylic Finish		
TFSZA Segmented Flex Screen with Polyester Felt Lower, Acrylic Upper Core - 60" H • Flex screen assembly includes aluminum powder-coated frame, core material, all trim, and feet • Non-magnetic acrylic core upper • Polyester felt is pinnable and non-magnetic • Specify adjustable glide feet or non-adjustable flat/bridge feet • Non-powered; no wire management • Fully assembled; includes all trim • Slotting under upper trim accepts screen-hung accessories • Segmentation at 29" • Elevated base does not accept power	TFSZA4260	<input type="checkbox"/> <input type="checkbox"/> <input type="checkbox"/> <input type="checkbox"/>	<input type="checkbox"/>	<input type="checkbox"/> <input type="checkbox"/>	<input type="checkbox"/> <input type="checkbox"/> <input type="checkbox"/> <input type="checkbox"/>	<input type="checkbox"/> <input type="checkbox"/>	83.00#	\$ 2127
	TFSZA4860	<input type="checkbox"/> <input type="checkbox"/> <input type="checkbox"/> <input type="checkbox"/>	<input type="checkbox"/>	<input type="checkbox"/> <input type="checkbox"/>	<input type="checkbox"/> <input type="checkbox"/> <input type="checkbox"/> <input type="checkbox"/>	<input type="checkbox"/> <input type="checkbox"/>	93.00#	2230
	TFSZA5460	<input type="checkbox"/> <input type="checkbox"/> <input type="checkbox"/> <input type="checkbox"/>	<input type="checkbox"/>	<input type="checkbox"/> <input type="checkbox"/>	<input type="checkbox"/> <input type="checkbox"/> <input type="checkbox"/> <input type="checkbox"/>	<input type="checkbox"/> <input type="checkbox"/>	98.00#	2452
	TFSZA6060	<input type="checkbox"/> <input type="checkbox"/> <input type="checkbox"/> <input type="checkbox"/>	<input type="checkbox"/>	<input type="checkbox"/> <input type="checkbox"/>	<input type="checkbox"/> <input type="checkbox"/> <input type="checkbox"/> <input type="checkbox"/>	<input type="checkbox"/> <input type="checkbox"/>	104.00#	2734
	TFSZA6660	<input type="checkbox"/> <input type="checkbox"/> <input type="checkbox"/> <input type="checkbox"/>	<input type="checkbox"/>	<input type="checkbox"/> <input type="checkbox"/>	<input type="checkbox"/> <input type="checkbox"/> <input type="checkbox"/> <input type="checkbox"/>	<input type="checkbox"/> <input type="checkbox"/>	108.00#	3056
	TFSZA7260	<input type="checkbox"/> <input type="checkbox"/> <input type="checkbox"/> <input type="checkbox"/>	<input type="checkbox"/>	<input type="checkbox"/> <input type="checkbox"/>	<input type="checkbox"/> <input type="checkbox"/> <input type="checkbox"/> <input type="checkbox"/>	<input type="checkbox"/> <input type="checkbox"/>	120.00#	3134
	TFSZA7860	<input type="checkbox"/> <input type="checkbox"/> <input type="checkbox"/> <input type="checkbox"/>	<input type="checkbox"/>	<input type="checkbox"/> <input type="checkbox"/>	<input type="checkbox"/> <input type="checkbox"/> <input type="checkbox"/> <input type="checkbox"/>	<input type="checkbox"/> <input type="checkbox"/>	128.00#	3159
	TFSZA8460	<input type="checkbox"/> <input type="checkbox"/> <input type="checkbox"/> <input type="checkbox"/>	<input type="checkbox"/>	<input type="checkbox"/> <input type="checkbox"/>	<input type="checkbox"/> <input type="checkbox"/> <input type="checkbox"/> <input type="checkbox"/>	<input type="checkbox"/> <input type="checkbox"/>	135.00#	3678
	TFSZA9060	<input type="checkbox"/> <input type="checkbox"/> <input type="checkbox"/> <input type="checkbox"/>	<input type="checkbox"/>	<input type="checkbox"/> <input type="checkbox"/>	<input type="checkbox"/> <input type="checkbox"/> <input type="checkbox"/> <input type="checkbox"/>	<input type="checkbox"/> <input type="checkbox"/>	143.00#	3706
TFSZA9660	<input type="checkbox"/> <input type="checkbox"/> <input type="checkbox"/> <input type="checkbox"/>	<input type="checkbox"/>	<input type="checkbox"/> <input type="checkbox"/>	<input type="checkbox"/> <input type="checkbox"/> <input type="checkbox"/> <input type="checkbox"/>	<input type="checkbox"/> <input type="checkbox"/>	150.00#	3731	

A **B** **C** **D** **E** **F**

HOW TO ORDER

- Indicate the following information on order form:
- Quantity of each item.
 - Model number, including options. See "How To Build a Model Number".
 - Any special service required.

Note:

- The indicates that a choice is required.
- The absence of the indicates that no choice is required.
- Alpha-numeric characters in place of indicate that no other alternatives are available.

HOW TO BUILD A MODEL NUMBER

- A** Select basic model.
- B** Select foot option.

FADJ	- Adjustable
FFLB	- Flat/Bridge
- C** Select top cap style.

F	- Flat aluminum top cap (standard)
N	- No top cap (specify for use with toppers)
- D** Select frame/trim color.
Refer to the **Product Color Options** page in this price list.
- E** Select lower polyester felt color.
Refer to the **Product Color Options** page in this price list.
- F** Select upper acrylic finish.
Refer to the **Product Color Options** page in this price list.

SPECIAL SERVICES

Special Carton Marking

With specially marked information N/C

Shipping

Ships **assembled, FOB Manitowoc, WI 54220, freight prepaid.** Freight class 70.

Specifications and prices are subject to change without prior notice.

Tattoo™ Flex Screens

Segmented Flex Screen with Fabric Lower, Magnetic Dry-Erasable Steel Upper Core



Tattoo™ Flex Screens

Segmented Flex Screen with Fabric Lower, Magnetic Dry-Erasable Steel Upper Core

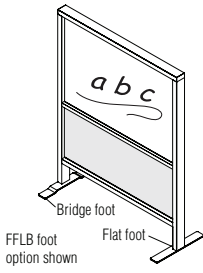
MODEL	MODEL NUMBER					Approx. Packaged Weight	Delivered Pricing Fabric Grade 1 & C.O.M.	Delivered Pricing Fabric Grade 2	Delivered Pricing Fabric Grade 3 & Pallas Vertical Fabric Grade PV	Delivered Pricing Pallas Vertical Fabric Grade PV1	Delivered Pricing Pallas Vertical Fabric Grade PV2
	Basic Model	Foot Option	Top Cap Style	Frame/Trim Color	Lower Fabric Color						
 <p>Segmented Flex Screen with Fabric Lower, Magnetic Dry-Erasable Steel Upper Core - 48" H</p> <ul style="list-style-type: none"> Flex screen assembly includes aluminum powder-coated frame, core material, all trim, and feet Upper segment features dry-erasable magnetic steel Lower segment features identical tackable fabric core on both sides, fabric pattern is railroaded Specify adjustable glide feet or non-adjustable flat/bridge feet Non-powered; no wire management Fully assembled; includes all trim Slotting under upper trim accepts screen-hung accessories Segmentation at 29" Elevated base does not accept power 	TFSFE4248	<input type="checkbox"/>	<input type="checkbox"/>	<input type="checkbox"/>	<input type="checkbox"/>	72.00#	\$ 1405	\$ 1433	\$ 1462	\$ 1476	\$ 1531
	TFSFE4848	<input type="checkbox"/>	<input type="checkbox"/>	<input type="checkbox"/>	<input type="checkbox"/>	78.00#	1447	1477	1505	1519	1578
	TFSFE5448	<input type="checkbox"/>	<input type="checkbox"/>	<input type="checkbox"/>	<input type="checkbox"/>	84.00#	1612	1643	1675	1690	1756
	TFSFE6048	<input type="checkbox"/>	<input type="checkbox"/>	<input type="checkbox"/>	<input type="checkbox"/>	90.00#	1678	1712	1746	1762	1830
	TFSFE6648	<input type="checkbox"/>	<input type="checkbox"/>	<input type="checkbox"/>	<input type="checkbox"/>	96.00#	1866	1904	1942	1959	2034
	TFSFE7248	<input type="checkbox"/>	<input type="checkbox"/>	<input type="checkbox"/>	<input type="checkbox"/>	102.00#	1936	1974	2011	2031	2108
	TFSFE7848	<input type="checkbox"/>	<input type="checkbox"/>	<input type="checkbox"/>	<input type="checkbox"/>	108.00#	2072	2110	2153	2173	2256
	TFSFE8448	<input type="checkbox"/>	<input type="checkbox"/>	<input type="checkbox"/>	<input type="checkbox"/>	114.00#	2095	2138	2179	2201	2283
	TFSFE9048	<input type="checkbox"/>	<input type="checkbox"/>	<input type="checkbox"/>	<input type="checkbox"/>	120.00#	2116	2158	2201	2221	2306
	TFSFE9648	<input type="checkbox"/>	<input type="checkbox"/>	<input type="checkbox"/>	<input type="checkbox"/>	126.00#	2157	2200	2243	2265	2351
<p>Segmented Flex Screen with Fabric Lower, Magnetic Dry-Erasable Steel Upper Core - 54" H</p> <ul style="list-style-type: none"> Flex screen assembly includes aluminum powder-coated frame, core material, all trim, and feet Upper segment features dry-erasable magnetic steel Lower segment features identical tackable fabric core on both sides, fabric pattern is railroaded Specify adjustable glide feet or non-adjustable flat/bridge feet Non-powered; no wire management Fully assembled; includes all trim Slotting under upper trim accepts screen-hung accessories Segmentation at 29" Elevated base does not accept power 	TFSFE4254	<input type="checkbox"/>	<input type="checkbox"/>	<input type="checkbox"/>	<input type="checkbox"/>	78.00#	\$ 1417	\$ 1445	\$ 1473	\$ 1487	\$ 1545
	TFSFE4854	<input type="checkbox"/>	<input type="checkbox"/>	<input type="checkbox"/>	<input type="checkbox"/>	84.00#	1535	1566	1595	1613	1674
	TFSFE5454	<input type="checkbox"/>	<input type="checkbox"/>	<input type="checkbox"/>	<input type="checkbox"/>	91.00#	1651	1684	1717	1733	1801
	TFSFE6054	<input type="checkbox"/>	<input type="checkbox"/>	<input type="checkbox"/>	<input type="checkbox"/>	102.00#	1720	1753	1789	1807	1874
	TFSFE6654	<input type="checkbox"/>	<input type="checkbox"/>	<input type="checkbox"/>	<input type="checkbox"/>	107.00#	1909	1947	1986	2004	2079
	TFSFE7254	<input type="checkbox"/>	<input type="checkbox"/>	<input type="checkbox"/>	<input type="checkbox"/>	111.00#	1977	2019	2057	2077	2157
	TFSFE7854	<input type="checkbox"/>	<input type="checkbox"/>	<input type="checkbox"/>	<input type="checkbox"/>	118.00#	2115	2157	2197	2219	2303
	TFSFE8454	<input type="checkbox"/>	<input type="checkbox"/>	<input type="checkbox"/>	<input type="checkbox"/>	125.00#	2139	2183	2225	2247	2333
	TFSFE9054	<input type="checkbox"/>	<input type="checkbox"/>	<input type="checkbox"/>	<input type="checkbox"/>	132.00#	2160	2203	2247	2268	2354
	TFSFE9654	<input type="checkbox"/>	<input type="checkbox"/>	<input type="checkbox"/>	<input type="checkbox"/>	138.00#	2202	2247	2290	2310	2401

A **B** **C** **D** **E**

HOW TO ORDER

- Indicate the following information on order form:
- Quantity of each item.
 - Model number, including options. See "How To Build a Model Number".
 - Any special service required.

Note:

- The indicates that a choice is required.
- The absence of the indicates that no choice is required.
- Alpha-numeric characters in place of indicate that no other alternatives are available.

HOW TO BUILD A MODEL NUMBER

- A** Select basic model.
- B** Select foot option.

FADJ	- Adjustable
FFLB	- Flat/Bridge
- C** Select top cap style.

F	- Flat aluminum top cap (standard)
N	- No top cap (specify for use with toppers)
- D** Select frame/trim color. Refer to the **Product Color Options** page in this price list.
- E** Select lower fabric color. Refer to ki.com/fabrics

INFORMATION

COM YARDAGE REQUIREMENTS

Screen Width/Length	Fabric Required
42	2.556
48	2.889
54	3.222
60	3.556
66	3.889
72	4.222
78	4.556
84	4.889
90	5.222
96	5.556

SPECIAL SERVICES

Special Carton Marking

With specially marked information N/C

Shipping

Ships assembled, FOB Manitowoc, WI 54220, freight prepaid. Freight class 70.

Specifications and prices are subject to change without prior notice.

Tattoo™ Flex Screens

Segmented Flex Screen with Fabric Lower, Magnetic Dry-Erasable Steel Upper Core



Tattoo™ Flex Screens

Segmented Flex Screen with Fabric Lower, Magnetic Dry-Erasable Steel Upper Core

MODEL	MODEL NUMBER					Approx. Packaged Weight	Delivered Pricing Fabric Grade 1 & C.O.M.	Delivered Pricing Fabric Grade 2	Delivered Pricing Fabric Grade 3 & Pallas Vertical Fabric Grade PV	Delivered Pricing Pallas Vertical Fabric Grade PV1	Delivered Pricing Pallas Vertical Fabric Grade PV2
	Basic Model	Foot Option	Top Cap Style	Frame/Trim Color	Lower Fabric Color						
TFSFE Segmented Flex Screen with Fabric Lower, Magnetic Dry-Erasable Steel Upper Core - 60" H <ul style="list-style-type: none"> Flex screen assembly includes aluminum powder-coated frame, core material, all trim, and feet Upper segment features dry-erasable magnetic steel Lower segment features identical tackable fabric core on both sides, fabric pattern is railroaded Specify adjustable glide feet or non-adjustable flat/bridge feet Non-powered; no wire management Fully assembled; includes all trim Slotting under upper trim accepts screen-hung accessories Segmentation at 29" Elevated base does not accept power 	TFSFE4260	<input type="checkbox"/> <input type="checkbox"/> <input type="checkbox"/> <input type="checkbox"/>	<input type="checkbox"/>	<input type="checkbox"/> <input type="checkbox"/>	<input type="checkbox"/> <input type="checkbox"/> <input type="checkbox"/> <input type="checkbox"/> <input type="checkbox"/>	83.00#	\$ 1558	\$ 1588	\$ 1619	\$ 1634	\$ 1698
	TFSFE4860	<input type="checkbox"/> <input type="checkbox"/> <input type="checkbox"/> <input type="checkbox"/>	<input type="checkbox"/>	<input type="checkbox"/> <input type="checkbox"/>	<input type="checkbox"/> <input type="checkbox"/> <input type="checkbox"/> <input type="checkbox"/> <input type="checkbox"/>	90.00#	1766	1804	1838	1857	1925
	TFSFE5460	<input type="checkbox"/> <input type="checkbox"/> <input type="checkbox"/> <input type="checkbox"/>	<input type="checkbox"/>	<input type="checkbox"/> <input type="checkbox"/>	<input type="checkbox"/> <input type="checkbox"/> <input type="checkbox"/> <input type="checkbox"/> <input type="checkbox"/>	102.00#	2025	2066	2107	2128	2208
	TFSFE6060	<input type="checkbox"/> <input type="checkbox"/> <input type="checkbox"/> <input type="checkbox"/>	<input type="checkbox"/>	<input type="checkbox"/> <input type="checkbox"/>	<input type="checkbox"/> <input type="checkbox"/> <input type="checkbox"/> <input type="checkbox"/> <input type="checkbox"/>	105.00#	2094	2137	2179	2201	2283
	TFSFE6660	<input type="checkbox"/> <input type="checkbox"/> <input type="checkbox"/> <input type="checkbox"/>	<input type="checkbox"/>	<input type="checkbox"/> <input type="checkbox"/>	<input type="checkbox"/> <input type="checkbox"/> <input type="checkbox"/> <input type="checkbox"/> <input type="checkbox"/>	108.00#	2332	2379	2426	2448	2418
	TFSFE7260	<input type="checkbox"/> <input type="checkbox"/> <input type="checkbox"/> <input type="checkbox"/>	<input type="checkbox"/>	<input type="checkbox"/> <input type="checkbox"/>	<input type="checkbox"/> <input type="checkbox"/> <input type="checkbox"/> <input type="checkbox"/> <input type="checkbox"/>	120.00#	2403	2450	2497	2521	2618
	TFSFE7860	<input type="checkbox"/> <input type="checkbox"/> <input type="checkbox"/> <input type="checkbox"/>	<input type="checkbox"/>	<input type="checkbox"/> <input type="checkbox"/>	<input type="checkbox"/> <input type="checkbox"/> <input type="checkbox"/> <input type="checkbox"/> <input type="checkbox"/>	128.00#	2632	2684	2738	2764	2869
	TFSFE8460	<input type="checkbox"/> <input type="checkbox"/> <input type="checkbox"/> <input type="checkbox"/>	<input type="checkbox"/>	<input type="checkbox"/> <input type="checkbox"/>	<input type="checkbox"/> <input type="checkbox"/> <input type="checkbox"/> <input type="checkbox"/> <input type="checkbox"/>	135.00#	2659	2712	2765	2792	2898
	TFSFE9060	<input type="checkbox"/> <input type="checkbox"/> <input type="checkbox"/> <input type="checkbox"/>	<input type="checkbox"/>	<input type="checkbox"/> <input type="checkbox"/>	<input type="checkbox"/> <input type="checkbox"/> <input type="checkbox"/> <input type="checkbox"/> <input type="checkbox"/>	143.00#	2680	2733	2788	2815	2922
	TFSFE9660	<input type="checkbox"/> <input type="checkbox"/> <input type="checkbox"/> <input type="checkbox"/>	<input type="checkbox"/>	<input type="checkbox"/> <input type="checkbox"/>	<input type="checkbox"/> <input type="checkbox"/> <input type="checkbox"/> <input type="checkbox"/> <input type="checkbox"/>	150.00#	2723	2777	2831	2860	2968

A **B** **C** **D** **E**

HOW TO ORDER

- Indicate the following information on order form:
- Quantity of each item.
 - Model number, including options. See "How To Build a Model Number".
 - Any special service required.

Note:

- The indicates that a choice is required.
- The absence of the indicates that no choice is required.
- Alpha-numeric characters in place of indicate that no other alternatives are available.

HOW TO BUILD A MODEL NUMBER

- A** Select basic model.
- B** Select foot option.

FADJ	- Adjustable
FFLB	- Flat/Bridge
- C** Select top cap style.

F	- Flat aluminum top cap (standard)
N	- No top cap (specify for use with toppers)
- D** Select frame/trim color. Refer to the **Product Color Options** page in this price list.
- E** Select lower fabric color. Refer to ki.com/fabrics

INFORMATION

COM YARDAGE REQUIREMENTS	
Screen Width/Length	Fabric Required
42	2.556
48	2.889
54	3.222
60	3.556
66	3.889
72	4.222
78	4.556
84	4.889
90	5.222
96	5.556

SPECIAL SERVICES

Special Carton Marking

With specially marked information N/C

Shipping

Ships **assembled, FOB Manitowoc, WI 54220, freight prepaid.** Freight class 70.

Specifications and prices are subject to change without prior notice.

Tattoo™ Flex Screens

Segmented Flex Screen with Fabric Lower, Thermally-Fused Laminate Upper Core



Tattoo™ Flex Screens

Segmented Flex Screen with Fabric Lower, Thermally-Fused Laminate Upper Core

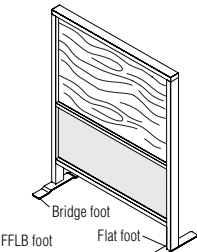
MODEL	MODEL NUMBER						Approx. Packaged Weight	Delivered Pricing Fabric Grade 1 & C.O.M.	Delivered Pricing Fabric Grade 2	Delivered Pricing Fabric Grade 3 & Pallas Vertical Fabric Grade PV	Delivered Pricing Pallas Vertical Fabric Grade PV1	Delivered Pricing Pallas Vertical Fabric Grade PV2	
	Basic Model	Foot Option	Top Cap Style	Frame/Trim Color	Lower Fabric Color	Upper Laminate Color							
 <p>FFLB foot option shown</p> <p>TFSFM</p> <p>Segmented Flex Screen with Fabric Lower, Thermally-Fused Laminate Upper Core - 48" H</p> <ul style="list-style-type: none"> Flex screen assembly includes aluminum powder-coated frame, core material, all trim, and feet Upper segment features non-magnetic thermally-fused laminate on both sides Lower segment features identical tackable fabric core on both sides, fabric pattern is railroaded Specify adjustable glide feet or non-adjustable flat/bridge feet Non-powered; no wire management Fully assembled; includes all trim Slotting under upper trim accepts screen-hung accessories Segmentation at 29" Elevated base does not accept power 	TFSFM4248	<input type="checkbox"/>	<input type="checkbox"/>	<input type="checkbox"/>	<input type="checkbox"/>	<input type="checkbox"/>	54.00#	\$ 1303	\$ 1330	\$ 1356	\$ 1369	\$ 1421	
	TFSFM4848	<input type="checkbox"/>	<input type="checkbox"/>	<input type="checkbox"/>	<input type="checkbox"/>	<input type="checkbox"/>	57.00#	1372	1400	1428	1440	1495	
	TFSFM5448	<input type="checkbox"/>	<input type="checkbox"/>	<input type="checkbox"/>	<input type="checkbox"/>	<input type="checkbox"/>	61.00#	1466	1495	1525	1540	1599	
	TFSFM6048	<input type="checkbox"/>	<input type="checkbox"/>	<input type="checkbox"/>	<input type="checkbox"/>	<input type="checkbox"/>	64.00#	1535	1566	1598	1613	1674	
	TFSFM6648	<input type="checkbox"/>	<input type="checkbox"/>	<input type="checkbox"/>	<input type="checkbox"/>	<input type="checkbox"/>	67.00#	1676	1709	1743	1760	1828	
	TFSFM7248	<input type="checkbox"/>	<input type="checkbox"/>	<input type="checkbox"/>	<input type="checkbox"/>	<input type="checkbox"/>	71.00#	1744	1780	1814	1831	1902	
	TFSFM7848	<input type="checkbox"/>	<input type="checkbox"/>	<input type="checkbox"/>	<input type="checkbox"/>	<input type="checkbox"/>	75.00#	1785	1820	1858	1874	1946	
	TFSFM8448	<input type="checkbox"/>	<input type="checkbox"/>	<input type="checkbox"/>	<input type="checkbox"/>	<input type="checkbox"/>	81.00#	1810	1847	1882	1902	1974	
	TFSFM9048	<input type="checkbox"/>	<input type="checkbox"/>	<input type="checkbox"/>	<input type="checkbox"/>	<input type="checkbox"/>	82.00#	1831	1867	1904	1922	1995	
	TFSFM9648	<input type="checkbox"/>	<input type="checkbox"/>	<input type="checkbox"/>	<input type="checkbox"/>	<input type="checkbox"/>	85.00#	1872	1909	1946	1965	2039	
TFSFM	<p>Segmented Flex Screen with Fabric Lower, Thermally-Fused Laminate Upper Core - 54" H</p> <ul style="list-style-type: none"> Flex screen assembly includes aluminum powder-coated frame, core material, all trim, and feet Upper segment features non-magnetic thermally-fused laminate on both sides Lower segment features identical tackable fabric core on both sides, fabric pattern is railroaded Specify adjustable glide feet or non-adjustable flat/bridge feet Non-powered; no wire management Fully assembled; includes all trim Slotting under upper trim accepts screen-hung accessories Segmentation at 29" Elevated base does not accept power 	TFSFM4254	<input type="checkbox"/>	<input type="checkbox"/>	<input type="checkbox"/>	<input type="checkbox"/>	<input type="checkbox"/>	57.00#	\$ 1343	\$ 1370	\$ 1398	\$ 1409	\$ 1463
		TFSFM4854	<input type="checkbox"/>	<input type="checkbox"/>	<input type="checkbox"/>	<input type="checkbox"/>	<input type="checkbox"/>	61.00#	1427	1454	1483	1496	1552
		TFSFM5454	<input type="checkbox"/>	<input type="checkbox"/>	<input type="checkbox"/>	<input type="checkbox"/>	<input type="checkbox"/>	65.00#	1535	1565	1595	1612	1674
		TFSFM6054	<input type="checkbox"/>	<input type="checkbox"/>	<input type="checkbox"/>	<input type="checkbox"/>	<input type="checkbox"/>	69.00#	1603	1634	1667	1684	1748
		TFSFM6654	<input type="checkbox"/>	<input type="checkbox"/>	<input type="checkbox"/>	<input type="checkbox"/>	<input type="checkbox"/>	73.00#	1744	1780	1815	1833	1902
		TFSFM7254	<input type="checkbox"/>	<input type="checkbox"/>	<input type="checkbox"/>	<input type="checkbox"/>	<input type="checkbox"/>	77.00#	1814	1849	1888	1904	1977
		TFSFM7854	<input type="checkbox"/>	<input type="checkbox"/>	<input type="checkbox"/>	<input type="checkbox"/>	<input type="checkbox"/>	81.00#	1857	1892	1930	1947	2022
		TFSFM8454	<input type="checkbox"/>	<input type="checkbox"/>	<input type="checkbox"/>	<input type="checkbox"/>	<input type="checkbox"/>	85.00#	1881	1920	1957	1976	2051
		TFSFM9054	<input type="checkbox"/>	<input type="checkbox"/>	<input type="checkbox"/>	<input type="checkbox"/>	<input type="checkbox"/>	89.00#	1902	1942	1978	1998	2074
		TFSFM9654	<input type="checkbox"/>	<input type="checkbox"/>	<input type="checkbox"/>	<input type="checkbox"/>	<input type="checkbox"/>	93.00#	1944	1981	2022	2040	2118

A **B** **C** **D** **E** **F**

HOW TO ORDER

- Indicate the following information on order form:
- Quantity of each item.
 - Model number, including options. See "How To Build a Model Number".
 - Any special service required.

Note: • The indicates that a choice is required.

- The absence of the indicates that no choice is required.
- Alpha-numeric characters in place of indicate that no other alternatives are available.

HOW TO BUILD A MODEL NUMBER

- A** Select basic model.
- B** Select foot option.

FADJ	- Adjustable
FFLB	- Flat/Bridge
- C** Select top cap style.

F	- Flat aluminum top cap (standard)
N	- No top cap (specify for use with toppers)
- D** Select frame/trim color. Refer to the **Product Color Options** page in this price list.
- E** Select lower fabric color. Refer to ki.com/fabrics
- F** Select upper laminate. Refer to the **Product Color Options** page in this price list.

INFORMATION

COM YARDAGE REQUIREMENTS	
Screen Width/Length	Fabric Required
42	2.556
48	2.889
54	3.222
60	3.556
66	3.889
72	4.222
78	4.556
84	4.889
90	5.222
96	5.556

SPECIAL SERVICES

Special Carton Marking

With specially marked information N/C

Shipping

Ships assembled, FOB Manitowoc, WI 54220, freight prepaid. Freight class 70.

Specifications and prices are subject to change without prior notice.

Tattoo™ Flex Screens

Segmented Flex Screen with Fabric Lower, Thermally-Fused Laminate Upper Core



Tattoo™ Flex Screens

Segmented Flex Screen with Fabric Lower, Thermally-Fused Laminate Upper Core

MODEL	MODEL NUMBER						Approx. Packaged Weight	Delivered Pricing Fabric Grade 1 & C.O.M.	Delivered Pricing Fabric Grade 2	Delivered Pricing Fabric Grade 3 & Pallas Vertical Fabric Grade PV	Delivered Pricing Pallas Vertical Fabric Grade PV1	Delivered Pricing Pallas Vertical Fabric Grade PV2
	Basic Model	Foot Option	Top Cap Style	Frame/Trim Color	Lower Fabric Color	Upper Laminate Color						
TFSFM Segmented Flex Screen with Fabric Lower, Thermally-Fused Laminate Upper Core - 60" H <ul style="list-style-type: none"> Flex screen assembly includes aluminum powder-coated frame, core material, all trim, and feet Upper segment features non-magnetic thermally-fused laminate on both sides Lower segment features identical tackable fabric core on both sides, fabric pattern is railroaded Specify adjustable glide feet or non-adjustable flat/bridge feet Non-powered; no wire management Fully assembled; includes all trim Slotting under upper trim accepts screen-hung accessories Segmentation at 29" Elevated base does not accept power 	TFSFM4260	<input type="checkbox"/> <input type="checkbox"/> <input type="checkbox"/> <input type="checkbox"/>	<input type="checkbox"/>	<input type="checkbox"/> <input type="checkbox"/>	<input type="checkbox"/> <input type="checkbox"/> <input type="checkbox"/> <input type="checkbox"/>	<input type="checkbox"/> <input type="checkbox"/> <input type="checkbox"/>	61.00#	\$ 1454	\$ 1483	\$ 1513	\$ 1527	\$ 1586
	TFSFM4860	<input type="checkbox"/> <input type="checkbox"/> <input type="checkbox"/> <input type="checkbox"/>	<input type="checkbox"/>	<input type="checkbox"/> <input type="checkbox"/>	<input type="checkbox"/> <input type="checkbox"/> <input type="checkbox"/> <input type="checkbox"/>	<input type="checkbox"/> <input type="checkbox"/> <input type="checkbox"/>	65.00#	1563	1594	1625	1643	1704
	TFSFM5460	<input type="checkbox"/> <input type="checkbox"/> <input type="checkbox"/> <input type="checkbox"/>	<input type="checkbox"/>	<input type="checkbox"/> <input type="checkbox"/>	<input type="checkbox"/> <input type="checkbox"/> <input type="checkbox"/> <input type="checkbox"/>	<input type="checkbox"/> <input type="checkbox"/> <input type="checkbox"/>	70.00#	1674	1707	1741	1757	1823
	TFSFM6060	<input type="checkbox"/> <input type="checkbox"/> <input type="checkbox"/> <input type="checkbox"/>	<input type="checkbox"/>	<input type="checkbox"/> <input type="checkbox"/>	<input type="checkbox"/> <input type="checkbox"/> <input type="checkbox"/> <input type="checkbox"/>	<input type="checkbox"/> <input type="checkbox"/> <input type="checkbox"/>	74.00#	1743	1777	1813	1830	1899
	TFSFM6660	<input type="checkbox"/> <input type="checkbox"/> <input type="checkbox"/> <input type="checkbox"/>	<input type="checkbox"/>	<input type="checkbox"/> <input type="checkbox"/>	<input type="checkbox"/> <input type="checkbox"/> <input type="checkbox"/> <input type="checkbox"/>	<input type="checkbox"/> <input type="checkbox"/> <input type="checkbox"/>	79.00#	1886	1922	1959	1978	2054
	TFSFM7260	<input type="checkbox"/> <input type="checkbox"/> <input type="checkbox"/> <input type="checkbox"/>	<input type="checkbox"/>	<input type="checkbox"/> <input type="checkbox"/>	<input type="checkbox"/> <input type="checkbox"/> <input type="checkbox"/> <input type="checkbox"/>	<input type="checkbox"/> <input type="checkbox"/> <input type="checkbox"/>	83.00#	1954	1993	2033	2052	2130
	TFSFM7860	<input type="checkbox"/> <input type="checkbox"/> <input type="checkbox"/> <input type="checkbox"/>	<input type="checkbox"/>	<input type="checkbox"/> <input type="checkbox"/>	<input type="checkbox"/> <input type="checkbox"/> <input type="checkbox"/> <input type="checkbox"/>	<input type="checkbox"/> <input type="checkbox"/> <input type="checkbox"/>	88.00#	1996	2036	2076	2095	2175
	TFSFM8460	<input type="checkbox"/> <input type="checkbox"/> <input type="checkbox"/> <input type="checkbox"/>	<input type="checkbox"/>	<input type="checkbox"/> <input type="checkbox"/>	<input type="checkbox"/> <input type="checkbox"/> <input type="checkbox"/> <input type="checkbox"/>	<input type="checkbox"/> <input type="checkbox"/> <input type="checkbox"/>	92.00#	2023	2063	2105	2125	2206
	TFSFM9060	<input type="checkbox"/> <input type="checkbox"/> <input type="checkbox"/> <input type="checkbox"/>	<input type="checkbox"/>	<input type="checkbox"/> <input type="checkbox"/>	<input type="checkbox"/> <input type="checkbox"/> <input type="checkbox"/> <input type="checkbox"/>	<input type="checkbox"/> <input type="checkbox"/> <input type="checkbox"/>	97.00#	2045	2086	2127	2146	2228
	TFSFM9660	<input type="checkbox"/> <input type="checkbox"/> <input type="checkbox"/> <input type="checkbox"/>	<input type="checkbox"/>	<input type="checkbox"/> <input type="checkbox"/>	<input type="checkbox"/> <input type="checkbox"/> <input type="checkbox"/> <input type="checkbox"/>	<input type="checkbox"/> <input type="checkbox"/> <input type="checkbox"/>	101.00#	2087	2129	2171	2191	2275

A **B** **C** **D** **E** **F**

HOW TO ORDER

- Indicate the following information on order form:
- Quantity of each item.
 - Model number, including options. See "How To Build a Model Number".
 - Any special service required.

Note:

- The indicates that a choice is required.
- The absence of the indicates that no choice is required.
- Alpha-numeric characters in place of indicate that no other alternatives are available.

HOW TO BUILD A MODEL NUMBER

- A** Select basic model.
- B** Select foot option.

FADJ	- Adjustable
FFLB	- Flat/Bridge
- C** Select top cap style.

F	- Flat aluminum top cap (standard)
N	- No top cap (specify for use with toppers)
- D** Select frame/trim color. Refer to the **Product Color Options** page in this price list.
- E** Select lower fabric color. Refer to ki.com/fabrics
- F** Select upper laminate. Refer to the **Product Color Options** page in this price list.

INFORMATION

COM YARDAGE REQUIREMENTS

Screen Width/Length	Fabric Required
42	2.556
48	2.889
54	3.222
60	3.556
66	3.889
72	4.222
78	4.556
84	4.889
90	5.222
96	5.556

SPECIAL SERVICES

Special Carton Marking

With specially marked information N/C

Shipping

Ships **assembled, FOB Manitowoc, WI 54220, freight prepaid.** Freight class 70.

Specifications and prices are subject to change without prior notice.

Tattoo™ Flex Screens

Segmented Flex Screen with Fabric Lower, Polyester Felt Upper Core



Tattoo™ Flex Screens

Segmented Flex Screen with Fabric Lower, Polyester Felt Upper Core

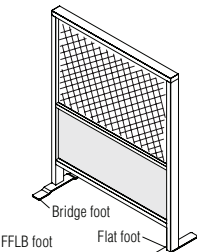
MODEL	MODEL NUMBER						Approx. Packaged Weight	Delivered Pricing Fabric Grade 1 & C.O.M.	Delivered Pricing Fabric Grade 2	Delivered Pricing Fabric Grade 3 & Pallas Vertical Fabric Grade PV	Delivered Pricing Pallas Vertical Fabric Grade PV1	Delivered Pricing Pallas Vertical Fabric Grade PV2
	Basic Model	Foot Option	Top Cap Style	Frame/Trim Color	Lower Fabric Color	Upper Polyester Felt Color						
 <p>Segmented Flex Screen with Fabric Lower, Polyester Felt Upper Core - 48" H</p> <ul style="list-style-type: none"> Flex screen assembly includes aluminum powder-coated frame, core material, all trim, and feet Upper segment features pinnable, non-magnetic polyester felt Lower segment features identical tackable fabric core on both sides, fabric pattern is railroaded Specify adjustable glide feet or non-adjustable flat/bridge feet Non-powered; no wire management Fully assembled; includes all trim Slotting under upper trim accepts screen-hung accessories Segmentation at 29" Elevated base does not accept power 	TFSFZ4248	<input type="checkbox"/>	<input type="checkbox"/>	<input type="checkbox"/>	<input type="checkbox"/>	<input type="checkbox"/>	54.00#	\$ 1314	\$ 1337	\$ 1365	\$ 1379	\$ 1431
	TFSFZ4848	<input type="checkbox"/>	<input type="checkbox"/>	<input type="checkbox"/>	<input type="checkbox"/>	<input type="checkbox"/>	57.00#	1449	1479	1506	1520	1579
	TFSFZ5448	<input type="checkbox"/>	<input type="checkbox"/>	<input type="checkbox"/>	<input type="checkbox"/>	<input type="checkbox"/>	61.00#	1591	1622	1653	1670	1733
	TFSFZ6048	<input type="checkbox"/>	<input type="checkbox"/>	<input type="checkbox"/>	<input type="checkbox"/>	<input type="checkbox"/>	64.00#	1856	1891	1928	1946	2021
	TFSFZ6648	<input type="checkbox"/>	<input type="checkbox"/>	<input type="checkbox"/>	<input type="checkbox"/>	<input type="checkbox"/>	67.00#	1995	2034	2075	2094	2174
	TFSFZ7248	<input type="checkbox"/>	<input type="checkbox"/>	<input type="checkbox"/>	<input type="checkbox"/>	<input type="checkbox"/>	71.00#	2062	2105	2145	2167	2249
	TFSFZ7848	<input type="checkbox"/>	<input type="checkbox"/>	<input type="checkbox"/>	<input type="checkbox"/>	<input type="checkbox"/>	75.00#	2105	2146	2189	2208	2292
	TFSFZ8448	<input type="checkbox"/>	<input type="checkbox"/>	<input type="checkbox"/>	<input type="checkbox"/>	<input type="checkbox"/>	81.00#	2129	2172	2214	2236	2321
	TFSFZ9048	<input type="checkbox"/>	<input type="checkbox"/>	<input type="checkbox"/>	<input type="checkbox"/>	<input type="checkbox"/>	82.00#	2149	2192	2236	2257	2343
	TFSFZ9648	<input type="checkbox"/>	<input type="checkbox"/>	<input type="checkbox"/>	<input type="checkbox"/>	<input type="checkbox"/>	85.00#	2190	2235	2277	2300	2387
<p>Segmented Flex Screen with Fabric Lower, Polyester Felt Upper Core - 54" H</p> <ul style="list-style-type: none"> Flex screen assembly includes aluminum powder-coated frame, core material, all trim, and feet Upper segment features pinnable, non-magnetic polyester felt Lower segment features identical tackable fabric core on both sides, fabric pattern is railroaded Specify adjustable glide feet or non-adjustable flat/bridge feet Non-powered; no wire management Fully assembled; includes all trim Slotting under upper trim accepts screen-hung accessories Segmentation at 29" Elevated base does not accept power 	TFSFZ4254	<input type="checkbox"/>	<input type="checkbox"/>	<input type="checkbox"/>	<input type="checkbox"/>	<input type="checkbox"/>	57.00#	\$ 1498	\$ 1528	\$ 1559	\$ 1572	\$ 1633
	TFSFZ4854	<input type="checkbox"/>	<input type="checkbox"/>	<input type="checkbox"/>	<input type="checkbox"/>	<input type="checkbox"/>	61.00#	1563	1594	1625	1642	1704
	TFSFZ5454	<input type="checkbox"/>	<input type="checkbox"/>	<input type="checkbox"/>	<input type="checkbox"/>	<input type="checkbox"/>	65.00#	1632	1665	1698	1713	1778
	TFSFZ6054	<input type="checkbox"/>	<input type="checkbox"/>	<input type="checkbox"/>	<input type="checkbox"/>	<input type="checkbox"/>	69.00#	1895	1933	1972	1991	2066
	TFSFZ6654	<input type="checkbox"/>	<input type="checkbox"/>	<input type="checkbox"/>	<input type="checkbox"/>	<input type="checkbox"/>	73.00#	2036	2077	2118	2138	2221
	TFSFZ7254	<input type="checkbox"/>	<input type="checkbox"/>	<input type="checkbox"/>	<input type="checkbox"/>	<input type="checkbox"/>	77.00#	2106	2148	2190	2211	2296
	TFSFZ7854	<input type="checkbox"/>	<input type="checkbox"/>	<input type="checkbox"/>	<input type="checkbox"/>	<input type="checkbox"/>	81.00#	2148	2191	2234	2254	2342
	TFSFZ8454	<input type="checkbox"/>	<input type="checkbox"/>	<input type="checkbox"/>	<input type="checkbox"/>	<input type="checkbox"/>	85.00#	2173	2217	2261	2282	2371
	TFSFZ9054	<input type="checkbox"/>	<input type="checkbox"/>	<input type="checkbox"/>	<input type="checkbox"/>	<input type="checkbox"/>	89.00#	2193	2238	2281	2304	2390
	TFSFZ9654	<input type="checkbox"/>	<input type="checkbox"/>	<input type="checkbox"/>	<input type="checkbox"/>	<input type="checkbox"/>	93.00#	2236	2280	2324	2348	2437

A **B** **C** **D** **E** **F**

HOW TO ORDER

- Indicate the following information on order form:
- Quantity of each item.
 - Model number, including options. See "How To Build a Model Number".
 - Any special service required.

Note: • The indicates that a choice is required.
 • The absence of the indicates that no choice is required.
 • Alpha-numeric characters in place of indicate that no other alternatives are available.

HOW TO BUILD A MODEL NUMBER

- A** Select basic model.
- B** Select foot option.

FADJ	- Adjustable
FFLB	- Flat/Bridge
- C** Select top cap style.

F	- Flat aluminum top cap (standard)
N	- No top cap (specify for use with toppers)
- D** Select frame/trim color.
Refer to the **Product Color Options** page in this price list.
- E** Select lower fabric color.
Refer to ki.com/fabrics
- F** Select upper polyester felt color.
Refer to the **Product Color Options** page in this price list.

INFORMATION

COM YARDAGE REQUIREMENTS

Screen Width/Length	Fabric Required
42	2.556
48	2.889
54	3.222
60	3.556
66	3.889
72	4.222
78	4.556
84	4.889
90	5.222
96	5.556

SPECIAL SERVICES

Special Carton Marking

With specially marked information N/C

Shipping

Ships assembled, FOB Manitowoc, WI 54220, freight prepaid. Freight class 70.

Specifications and prices are subject to change without prior notice.

Tattoo™ Flex Screens

Segmented Flex Screen with Fabric Lower, Polyester Felt Upper Core



Tattoo™ Flex Screens

Segmented Flex Screen with Fabric Lower, Polyester Felt Upper Core

MODEL	MODEL NUMBER						Approx. Packaged Weight	Delivered Pricing Fabric Grade 1 & C.O.M.	Delivered Pricing Fabric Grade 2	Delivered Pricing Fabric Grade 3 & Pallas Vertical Fabric Grade PV	Delivered Pricing Pallas Vertical Fabric Grade PV1	Delivered Pricing Pallas Vertical Fabric Grade PV2	
	Basic Model	Foot Option	Top Cap Style	Frame/Trim Color	Lower Fabric Color	Upper Polyester Felt Color							
TFSFZ	Segmented Flex Screen with Fabric Lower, Polyester Felt Upper Core - 60" H • Flex screen assembly includes aluminum powder-coated frame, core material, all trim, and feet • Upper segment features pinnable, non-magnetic polyester felt • Lower segment features identical tackable fabric core on both sides, fabric pattern is railroaded • Specify adjustable glide feet or non-adjustable flat/bridge feet • Non-powered; no wire management • Fully assembled; includes all trim • Slotting under upper trim accepts screen-hung accessories • Segmentation at 29" • Elevated base does not accept power	TFSFZ4260	<input type="checkbox"/> <input type="checkbox"/> <input type="checkbox"/> <input type="checkbox"/>	<input type="checkbox"/>	<input type="checkbox"/> <input type="checkbox"/>	<input type="checkbox"/> <input type="checkbox"/> <input type="checkbox"/> <input type="checkbox"/> <input type="checkbox"/> <input type="checkbox"/>	<input type="checkbox"/> <input type="checkbox"/> <input type="checkbox"/> <input type="checkbox"/> <input type="checkbox"/> <input type="checkbox"/>	61.00#	\$ 1665	\$ 1699	\$ 1731	\$ 1749	\$ 1815
		TFSFZ4860	<input type="checkbox"/> <input type="checkbox"/> <input type="checkbox"/> <input type="checkbox"/>	<input type="checkbox"/>	<input type="checkbox"/> <input type="checkbox"/>	<input type="checkbox"/> <input type="checkbox"/> <input type="checkbox"/> <input type="checkbox"/> <input type="checkbox"/> <input type="checkbox"/>	<input type="checkbox"/> <input type="checkbox"/> <input type="checkbox"/> <input type="checkbox"/> <input type="checkbox"/> <input type="checkbox"/>	65.00#	1765	1802	1837	1856	1924
		TFSFZ5460	<input type="checkbox"/> <input type="checkbox"/> <input type="checkbox"/> <input type="checkbox"/>	<input type="checkbox"/>	<input type="checkbox"/> <input type="checkbox"/>	<input type="checkbox"/> <input type="checkbox"/> <input type="checkbox"/> <input type="checkbox"/> <input type="checkbox"/> <input type="checkbox"/>	<input type="checkbox"/> <input type="checkbox"/> <input type="checkbox"/> <input type="checkbox"/> <input type="checkbox"/> <input type="checkbox"/>	70.00#	1965	2004	2044	2063	2142
		TFSFZ6060	<input type="checkbox"/> <input type="checkbox"/> <input type="checkbox"/> <input type="checkbox"/>	<input type="checkbox"/>	<input type="checkbox"/> <input type="checkbox"/>	<input type="checkbox"/> <input type="checkbox"/> <input type="checkbox"/> <input type="checkbox"/> <input type="checkbox"/> <input type="checkbox"/>	<input type="checkbox"/> <input type="checkbox"/> <input type="checkbox"/> <input type="checkbox"/> <input type="checkbox"/> <input type="checkbox"/>	74.00#	2404	2451	2500	2522	2619
		TFSFZ6660	<input type="checkbox"/> <input type="checkbox"/> <input type="checkbox"/> <input type="checkbox"/>	<input type="checkbox"/>	<input type="checkbox"/> <input type="checkbox"/>	<input type="checkbox"/> <input type="checkbox"/> <input type="checkbox"/> <input type="checkbox"/> <input type="checkbox"/> <input type="checkbox"/>	<input type="checkbox"/> <input type="checkbox"/> <input type="checkbox"/> <input type="checkbox"/> <input type="checkbox"/> <input type="checkbox"/>	79.00#	2546	2595	2512	2674	2775
		TFSFZ7260	<input type="checkbox"/> <input type="checkbox"/> <input type="checkbox"/> <input type="checkbox"/>	<input type="checkbox"/>	<input type="checkbox"/> <input type="checkbox"/>	<input type="checkbox"/> <input type="checkbox"/> <input type="checkbox"/> <input type="checkbox"/> <input type="checkbox"/> <input type="checkbox"/>	<input type="checkbox"/> <input type="checkbox"/> <input type="checkbox"/> <input type="checkbox"/> <input type="checkbox"/> <input type="checkbox"/>	83.00#	2615	2667	2718	2745	2849
		TFSFZ7860	<input type="checkbox"/> <input type="checkbox"/> <input type="checkbox"/> <input type="checkbox"/>	<input type="checkbox"/>	<input type="checkbox"/> <input type="checkbox"/>	<input type="checkbox"/> <input type="checkbox"/> <input type="checkbox"/> <input type="checkbox"/> <input type="checkbox"/> <input type="checkbox"/>	<input type="checkbox"/> <input type="checkbox"/> <input type="checkbox"/> <input type="checkbox"/> <input type="checkbox"/> <input type="checkbox"/>	88.00#	2656	2709	2763	2789	2895
		TFSFZ8460	<input type="checkbox"/> <input type="checkbox"/> <input type="checkbox"/> <input type="checkbox"/>	<input type="checkbox"/>	<input type="checkbox"/> <input type="checkbox"/>	<input type="checkbox"/> <input type="checkbox"/> <input type="checkbox"/> <input type="checkbox"/> <input type="checkbox"/> <input type="checkbox"/>	<input type="checkbox"/> <input type="checkbox"/> <input type="checkbox"/> <input type="checkbox"/> <input type="checkbox"/> <input type="checkbox"/>	92.00#	2683	2738	2791	2817	2925
		TFSFZ9060	<input type="checkbox"/> <input type="checkbox"/> <input type="checkbox"/> <input type="checkbox"/>	<input type="checkbox"/>	<input type="checkbox"/> <input type="checkbox"/>	<input type="checkbox"/> <input type="checkbox"/> <input type="checkbox"/> <input type="checkbox"/> <input type="checkbox"/> <input type="checkbox"/>	<input type="checkbox"/> <input type="checkbox"/> <input type="checkbox"/> <input type="checkbox"/> <input type="checkbox"/> <input type="checkbox"/>	97.00#	2706	2760	2813	2840	2948
		TFSFZ9660	<input type="checkbox"/> <input type="checkbox"/> <input type="checkbox"/> <input type="checkbox"/>	<input type="checkbox"/>	<input type="checkbox"/> <input type="checkbox"/>	<input type="checkbox"/> <input type="checkbox"/> <input type="checkbox"/> <input type="checkbox"/> <input type="checkbox"/> <input type="checkbox"/>	<input type="checkbox"/> <input type="checkbox"/> <input type="checkbox"/> <input type="checkbox"/> <input type="checkbox"/> <input type="checkbox"/>	101.00#	2748	2804	2858	2883	2995

A **B** **C** **D** **E** **F**

HOW TO ORDER

- Indicate the following information on order form:
- Quantity of each item.
 - Model number, including options. See "How To Build a Model Number".
 - Any special service required.

Note:

- The indicates that a choice is required.
- The absence of the indicates that no choice is required.
- Alpha-numeric characters in place of indicate that no other alternatives are available.

HOW TO BUILD A MODEL NUMBER

- A** Select basic model.
- B** Select foot option.

FADJ	- Adjustable
FFLB	- Flat/Bridge
- C** Select top cap style.

F	- Flat aluminum top cap (standard)
N	- No top cap (specify for use with toppers)
- D** Select frame/trim color. Refer to the **Product Color Options** page in this price list.
- E** Select lower fabric color. Refer to ki.com/fabrics
- F** Select upper polyester felt color. Refer to the **Product Color Options** page in this price list.

INFORMATION

COM YARDAGE REQUIREMENTS	
Screen Width/Length	Fabric Required
42	2.556
48	2.889
54	3.222
60	3.556
66	3.889
72	4.222
78	4.556
84	4.889
90	5.222
96	5.556

SPECIAL SERVICES

Special Carton Marking

With specially marked information N/C

Shipping

Ships **assembled, FOB Manitowoc, WI 54220, freight prepaid.** Freight class 70.

Specifications and prices are subject to change without prior notice.

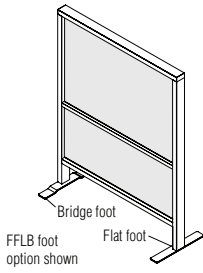

MODEL	MODEL NUMBER					Approx. Packaged Weight	Delivered Pricing Fabric Grade 1 & C.O.M.	Delivered Pricing Fabric Grade 2	Delivered Pricing Fabric Grade 3 & Pallas Vertical Fabric Grade PV	Delivered Pricing Pallas Vertical Fabric Grade PV1	Delivered Pricing Pallas Vertical Fabric Grade PV2
	Basic Model	Foot Option	Top Cap Style	Frame/Trim Color	Fabric Color						
 <p>Segmented Flex Screen with Fabric Lower and Upper Core - 48" H</p> <ul style="list-style-type: none"> Flex screen assembly includes aluminum powder-coated frame, core material, all trim, and feet Upper and lower segments feature identical tackable fabric core on both sides, fabric pattern is railroaded Fabric segments are non-magnetic Specify adjustable glide feet or non-adjustable flat/bridge feet Non-powered; no wire management Slotting under upper trim accepts screen-hung accessories Segmentation at 29" Elevated base does not accept power 	TFSFF4248	<input type="checkbox"/> <input type="checkbox"/> <input type="checkbox"/> <input type="checkbox"/>	<input type="checkbox"/>	<input type="checkbox"/> <input type="checkbox"/>	<input type="checkbox"/> <input type="checkbox"/> <input type="checkbox"/> <input type="checkbox"/> <input type="checkbox"/> <input type="checkbox"/>	54.00#	\$ 1460	\$ 1517	\$ 1576	\$ 1620	\$ 1722
	TFSFF4848	<input type="checkbox"/> <input type="checkbox"/> <input type="checkbox"/> <input type="checkbox"/>	<input type="checkbox"/>	<input type="checkbox"/> <input type="checkbox"/>	<input type="checkbox"/> <input type="checkbox"/> <input type="checkbox"/> <input type="checkbox"/> <input type="checkbox"/> <input type="checkbox"/>	57.00#	1530	1591	1651	1698	1805
	TFSFF5448	<input type="checkbox"/> <input type="checkbox"/> <input type="checkbox"/> <input type="checkbox"/>	<input type="checkbox"/>	<input type="checkbox"/> <input type="checkbox"/>	<input type="checkbox"/> <input type="checkbox"/> <input type="checkbox"/> <input type="checkbox"/> <input type="checkbox"/> <input type="checkbox"/>	61.00#	1598	1660	1727	1774	1886
	TFSFF6048	<input type="checkbox"/> <input type="checkbox"/> <input type="checkbox"/> <input type="checkbox"/>	<input type="checkbox"/>	<input type="checkbox"/> <input type="checkbox"/>	<input type="checkbox"/> <input type="checkbox"/> <input type="checkbox"/> <input type="checkbox"/> <input type="checkbox"/> <input type="checkbox"/>	64.00#	1708	1776	1845	1894	2014
	TFSFF6648	<input type="checkbox"/> <input type="checkbox"/> <input type="checkbox"/> <input type="checkbox"/>	<input type="checkbox"/>	<input type="checkbox"/> <input type="checkbox"/>	<input type="checkbox"/> <input type="checkbox"/> <input type="checkbox"/> <input type="checkbox"/> <input type="checkbox"/> <input type="checkbox"/>	67.00#	1900	1976	2053	2109	2243
	TFSFF7248	<input type="checkbox"/> <input type="checkbox"/> <input type="checkbox"/> <input type="checkbox"/>	<input type="checkbox"/>	<input type="checkbox"/> <input type="checkbox"/>	<input type="checkbox"/> <input type="checkbox"/> <input type="checkbox"/> <input type="checkbox"/> <input type="checkbox"/> <input type="checkbox"/>	71.00#	1970	2048	2127	2186	2323
	TFSFF7848	<input type="checkbox"/> <input type="checkbox"/> <input type="checkbox"/> <input type="checkbox"/>	<input type="checkbox"/>	<input type="checkbox"/> <input type="checkbox"/>	<input type="checkbox"/> <input type="checkbox"/> <input type="checkbox"/> <input type="checkbox"/> <input type="checkbox"/> <input type="checkbox"/>	75.00#	2052	2133	2216	2277	2420
	TFSFF8448	<input type="checkbox"/> <input type="checkbox"/> <input type="checkbox"/> <input type="checkbox"/>	<input type="checkbox"/>	<input type="checkbox"/> <input type="checkbox"/>	<input type="checkbox"/> <input type="checkbox"/> <input type="checkbox"/> <input type="checkbox"/> <input type="checkbox"/> <input type="checkbox"/>	81.00#	2082	2165	2249	2310	2457
	TFSFF9048	<input type="checkbox"/> <input type="checkbox"/> <input type="checkbox"/> <input type="checkbox"/>	<input type="checkbox"/>	<input type="checkbox"/> <input type="checkbox"/>	<input type="checkbox"/> <input type="checkbox"/> <input type="checkbox"/> <input type="checkbox"/> <input type="checkbox"/> <input type="checkbox"/>	82.00#	2143	2228	2316	2379	2529
	TFSFF9648	<input type="checkbox"/> <input type="checkbox"/> <input type="checkbox"/> <input type="checkbox"/>	<input type="checkbox"/>	<input type="checkbox"/> <input type="checkbox"/>	<input type="checkbox"/> <input type="checkbox"/> <input type="checkbox"/> <input type="checkbox"/> <input type="checkbox"/> <input type="checkbox"/>	85.00#	2185	2272	2358	2426	2578
<p>Segmented Flex Screen with Fabric Lower and Upper Core - 54" H</p> <ul style="list-style-type: none"> Flex screen assembly includes aluminum powder-coated frame, core material, all trim, and feet Upper and lower segments feature identical tackable fabric core on both sides, fabric pattern is railroaded Fabric segments are non-magnetic Specify adjustable glide feet or non-adjustable flat/bridge feet Non-powered; no wire management Slotting under upper trim accepts screen-hung accessories Segmentation at 29" Elevated base does not accept power 	TFSFF4254	<input type="checkbox"/> <input type="checkbox"/> <input type="checkbox"/> <input type="checkbox"/>	<input type="checkbox"/>	<input type="checkbox"/> <input type="checkbox"/>	<input type="checkbox"/> <input type="checkbox"/> <input type="checkbox"/> <input type="checkbox"/> <input type="checkbox"/> <input type="checkbox"/>	57.00#	\$ 1493	\$ 1551	\$ 1613	\$ 1657	\$ 1762
	TFSFF4854	<input type="checkbox"/> <input type="checkbox"/> <input type="checkbox"/> <input type="checkbox"/>	<input type="checkbox"/>	<input type="checkbox"/> <input type="checkbox"/>	<input type="checkbox"/> <input type="checkbox"/> <input type="checkbox"/> <input type="checkbox"/> <input type="checkbox"/> <input type="checkbox"/>	61.00#	1569	1632	1695	1742	1850
	TFSFF5454	<input type="checkbox"/> <input type="checkbox"/> <input type="checkbox"/> <input type="checkbox"/>	<input type="checkbox"/>	<input type="checkbox"/> <input type="checkbox"/>	<input type="checkbox"/> <input type="checkbox"/> <input type="checkbox"/> <input type="checkbox"/> <input type="checkbox"/> <input type="checkbox"/>	65.00#	1637	1704	1767	1818	1932
	TFSFF6054	<input type="checkbox"/> <input type="checkbox"/> <input type="checkbox"/> <input type="checkbox"/>	<input type="checkbox"/>	<input type="checkbox"/> <input type="checkbox"/>	<input type="checkbox"/> <input type="checkbox"/> <input type="checkbox"/> <input type="checkbox"/> <input type="checkbox"/> <input type="checkbox"/>	69.00#	1749	1818	1890	1943	2063
	TFSFF6654	<input type="checkbox"/> <input type="checkbox"/> <input type="checkbox"/> <input type="checkbox"/>	<input type="checkbox"/>	<input type="checkbox"/> <input type="checkbox"/>	<input type="checkbox"/> <input type="checkbox"/> <input type="checkbox"/> <input type="checkbox"/> <input type="checkbox"/> <input type="checkbox"/>	73.00#	1944	2021	2099	2157	2292
	TFSFF7254	<input type="checkbox"/> <input type="checkbox"/> <input type="checkbox"/> <input type="checkbox"/>	<input type="checkbox"/>	<input type="checkbox"/> <input type="checkbox"/>	<input type="checkbox"/> <input type="checkbox"/> <input type="checkbox"/> <input type="checkbox"/> <input type="checkbox"/> <input type="checkbox"/>	77.00#	2011	2092	2172	2234	2374
	TFSFF7854	<input type="checkbox"/> <input type="checkbox"/> <input type="checkbox"/> <input type="checkbox"/>	<input type="checkbox"/>	<input type="checkbox"/> <input type="checkbox"/>	<input type="checkbox"/> <input type="checkbox"/> <input type="checkbox"/> <input type="checkbox"/> <input type="checkbox"/> <input type="checkbox"/>	81.00#	2094	2179	2264	2324	2472
	TFSFF8454	<input type="checkbox"/> <input type="checkbox"/> <input type="checkbox"/> <input type="checkbox"/>	<input type="checkbox"/>	<input type="checkbox"/> <input type="checkbox"/>	<input type="checkbox"/> <input type="checkbox"/> <input type="checkbox"/> <input type="checkbox"/> <input type="checkbox"/> <input type="checkbox"/>	85.00#	2127	2211	2297	2361	2509
	TFSFF9054	<input type="checkbox"/> <input type="checkbox"/> <input type="checkbox"/> <input type="checkbox"/>	<input type="checkbox"/>	<input type="checkbox"/> <input type="checkbox"/>	<input type="checkbox"/> <input type="checkbox"/> <input type="checkbox"/> <input type="checkbox"/> <input type="checkbox"/> <input type="checkbox"/>	89.00#	2189	2276	2364	2430	2581
	TFSFF9654	<input type="checkbox"/> <input type="checkbox"/> <input type="checkbox"/> <input type="checkbox"/>	<input type="checkbox"/>	<input type="checkbox"/> <input type="checkbox"/>	<input type="checkbox"/> <input type="checkbox"/> <input type="checkbox"/> <input type="checkbox"/> <input type="checkbox"/> <input type="checkbox"/>	93.00#	2230	2320	2408	2474	2632

A **B** **C** **D** **E**

HOW TO ORDER

- Indicate the following information on order form:
- Quantity of each item.
 - Model number, including options. See "How To Build a Model Number".
 - Any special service required.

Note:

- The indicates that a choice is required.
- The absence of the indicates that no choice is required.
- Alpha-numeric characters in place of indicate that no other alternatives are available.

HOW TO BUILD A MODEL NUMBER

- A** Select basic model.
- B** Select foot option.

FADJ	- Adjustable
FFLB	- Flat/Bridge
- C** Select top cap style.

F	- Flat aluminum top cap (standard)
N	- No top cap (specify for use with toppers)
- D** Select frame/trim color. Refer to the **Product Color Options** page in this price list.
- E** Select fabric color. Refer to ki.com/fabrics

INFORMATION

COM YARDAGE REQUIREMENTS	
Screen Width/Length	Fabric Required
42	2.556
48	2.889
54	3.222
60	3.556
66	3.889
72	4.222
78	4.556
84	4.889
90	5.222
96	5.556

SPECIAL SERVICES

Special Carton Marking

With specially marked information N/C

Shipping

Ships assembled, FOB Manitowoc, WI 54220, freight prepaid. Freight class 70.

Specifications and prices are subject to change without prior notice.



MODEL	MODEL NUMBER					Approx. Packaged Weight	Delivered Pricing Fabric Grade 1 & C.O.M.	Delivered Pricing Fabric Grade 2	Delivered Pricing Fabric Grade 3 & Pallas Vertical Fabric Grade PV	Delivered Pricing Pallas Vertical Fabric Grade PV1	Delivered Pricing Pallas Vertical Fabric Grade PV2
	Basic Model	Foot Option	Top Cap Style	Frame/Trim Color	Fabric Color						
TFSFF Segmented Flex Screen with Fabric Lower and Upper Core - 60" H <ul style="list-style-type: none"> Flex screen assembly includes aluminum powder-coated frame, core material, all trim, and feet Upper and lower segments feature identical tackable fabric core on both sides, fabric pattern is railroaded Fabric segments are non-magnetic Specify adjustable glide feet or non-adjustable flat/bridge feet Non-powered; no wire management Slotting under upper trim accepts screen-hung accessories Segmentation at 29" Elevated base does not accept power 	TFSFF4260	<input type="checkbox"/> <input type="checkbox"/> <input type="checkbox"/> <input type="checkbox"/>	<input type="checkbox"/>	<input type="checkbox"/> <input type="checkbox"/>	<input type="checkbox"/> <input type="checkbox"/> <input type="checkbox"/> <input type="checkbox"/> <input type="checkbox"/>	61.00#	\$ 1696	\$ 1763	\$ 1831	\$ 1882	\$ 2002
	TFSFF4860	<input type="checkbox"/> <input type="checkbox"/> <input type="checkbox"/> <input type="checkbox"/>	<input type="checkbox"/>	<input type="checkbox"/> <input type="checkbox"/>	<input type="checkbox"/> <input type="checkbox"/> <input type="checkbox"/> <input type="checkbox"/> <input type="checkbox"/>	65.00#	1753	1824	1894	1947	2072
	TFSFF5460	<input type="checkbox"/> <input type="checkbox"/> <input type="checkbox"/> <input type="checkbox"/>	<input type="checkbox"/>	<input type="checkbox"/> <input type="checkbox"/>	<input type="checkbox"/> <input type="checkbox"/> <input type="checkbox"/> <input type="checkbox"/> <input type="checkbox"/>	70.00#	1824	1896	1971	2024	2152
	TFSFF6060	<input type="checkbox"/> <input type="checkbox"/> <input type="checkbox"/> <input type="checkbox"/>	<input type="checkbox"/>	<input type="checkbox"/> <input type="checkbox"/>	<input type="checkbox"/> <input type="checkbox"/> <input type="checkbox"/> <input type="checkbox"/> <input type="checkbox"/>	74.00#	1936	2011	2090	2149	2283
	TFSFF6660	<input type="checkbox"/> <input type="checkbox"/> <input type="checkbox"/> <input type="checkbox"/>	<input type="checkbox"/>	<input type="checkbox"/> <input type="checkbox"/>	<input type="checkbox"/> <input type="checkbox"/> <input type="checkbox"/> <input type="checkbox"/> <input type="checkbox"/>	79.00#	2177	2265	2351	2417	2568
	TFSFF7260	<input type="checkbox"/> <input type="checkbox"/> <input type="checkbox"/> <input type="checkbox"/>	<input type="checkbox"/>	<input type="checkbox"/> <input type="checkbox"/>	<input type="checkbox"/> <input type="checkbox"/> <input type="checkbox"/> <input type="checkbox"/> <input type="checkbox"/>	83.00#	2247	2336	2427	2494	2651
	TFSFF7860	<input type="checkbox"/> <input type="checkbox"/> <input type="checkbox"/> <input type="checkbox"/>	<input type="checkbox"/>	<input type="checkbox"/> <input type="checkbox"/>	<input type="checkbox"/> <input type="checkbox"/> <input type="checkbox"/> <input type="checkbox"/> <input type="checkbox"/>	88.00#	2331	2424	2517	2588	2750
	TFSFF8460	<input type="checkbox"/> <input type="checkbox"/> <input type="checkbox"/> <input type="checkbox"/>	<input type="checkbox"/>	<input type="checkbox"/> <input type="checkbox"/>	<input type="checkbox"/> <input type="checkbox"/> <input type="checkbox"/> <input type="checkbox"/> <input type="checkbox"/>	92.00#	2363	2459	2550	2623	2788
	TFSFF9060	<input type="checkbox"/> <input type="checkbox"/> <input type="checkbox"/> <input type="checkbox"/>	<input type="checkbox"/>	<input type="checkbox"/> <input type="checkbox"/>	<input type="checkbox"/> <input type="checkbox"/> <input type="checkbox"/> <input type="checkbox"/> <input type="checkbox"/>	97.00#	2426	2522	2620	2694	2862
	TFSFF9660	<input type="checkbox"/> <input type="checkbox"/> <input type="checkbox"/> <input type="checkbox"/>	<input type="checkbox"/>	<input type="checkbox"/> <input type="checkbox"/>	<input type="checkbox"/> <input type="checkbox"/> <input type="checkbox"/> <input type="checkbox"/> <input type="checkbox"/>	101.00#	2468	2566	2664	2739	2912

A **B** **C** **D** **E**

HOW TO ORDER

- Indicate the following information on order form:
- Quantity of each item.
 - Model number, including options. See "How To Build a Model Number".
 - Any special service required.

Note:

- The indicates that a choice is required.
- The absence of the indicates that no choice is required.
- Alpha-numeric characters in place of indicate that no other alternatives are available.

HOW TO BUILD A MODEL NUMBER

- A** Select basic model.
- B** Select foot option.

FADJ	- Adjustable
FFLB	- Flat/Bridge
- C** Select top cap style.

F	- Flat aluminum top cap (standard)
N	- No top cap (specify for use with toppers)
- D** Select frame/trim color.
Refer to the **Product Color Options** page in this price list.
- E** Select fabric color.
Refer to ki.com/fabrics

INFORMATION

COM YARDAGE REQUIREMENTS

Screen Width/Length	Fabric Required
42	2.556
48	2.889
54	3.222
60	3.556
66	3.889
72	4.222
78	4.556
84	4.889
90	5.222
96	5.556

SPECIAL SERVICES

Special Carton Marking
With specially marked information N/C

Shipping
Ships **assembled, FOB Manitowoc, WI 54220, freight prepaid.** Freight class 70.

Specifications and prices are subject to change without prior notice.

Tattoo™ Flex Screens

Segmented Flex Screen with Fabric Lower, Fluted Polycarbonate Upper Core



Tattoo™ Flex Screens

Segmented Flex Screen with Fabric Lower, Fluted Polycarbonate Upper Core

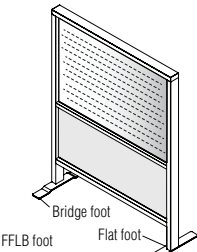
MODEL	MODEL NUMBER					Approx. Packaged Weight	Delivered Pricing Fabric Grade 1 & C.O.M.	Delivered Pricing Fabric Grade 2	Delivered Pricing Fabric Grade 3 & Pallas Vertical Fabric Grade PV	Delivered Pricing Pallas Vertical Fabric Grade PV1	Delivered Pricing Pallas Vertical Fabric Grade PV2	
	Basic Model	Foot Option	Top Cap Style	Frame/Trim Color	Lower Fabric Color							
 <p>FFLB foot option shown</p> <p>TFSFP</p> <p>Segmented Flex Screen with Fabric Lower, Fluted Polycarbonate Upper Core - 48" H</p> <ul style="list-style-type: none"> Flex screen assembly includes aluminum powder-coated frame, core material, all trim, and feet Upper segment features non-magnetic semi-transparent fluted polycarbonate Lower segment features identical tackable fabric core on both sides, fabric pattern is railroaded Specify adjustable glide feet or non-adjustable flat/bridge feet Non-powered; no wire management Fully assembled; includes all trim Slotting under upper trim accepts screen-hung accessories Segmentation at 29" Elevated base does not accept power Fluting runs horizontal 	TFSFP4248	<input type="checkbox"/> <input type="checkbox"/> <input type="checkbox"/> <input type="checkbox"/>	<input type="checkbox"/>	<input type="checkbox"/>	<input type="checkbox"/> <input type="checkbox"/> <input type="checkbox"/> <input type="checkbox"/>	54.00#	\$ 1436	\$ 1464	\$ 1493	\$ 1507	\$ 1565	
	TFSFP4848	<input type="checkbox"/> <input type="checkbox"/> <input type="checkbox"/> <input type="checkbox"/>	<input type="checkbox"/>	<input type="checkbox"/>	<input type="checkbox"/> <input type="checkbox"/> <input type="checkbox"/> <input type="checkbox"/>	57.00#	1517	1548	1578	1593	1653	
	TFSFP5448	<input type="checkbox"/> <input type="checkbox"/> <input type="checkbox"/> <input type="checkbox"/>	<input type="checkbox"/>	<input type="checkbox"/>	<input type="checkbox"/> <input type="checkbox"/> <input type="checkbox"/> <input type="checkbox"/>	61.00#	1612	1644	1676	1690	1756	
	TFSFP6048	<input type="checkbox"/> <input type="checkbox"/> <input type="checkbox"/> <input type="checkbox"/>	<input type="checkbox"/>	<input type="checkbox"/>	<input type="checkbox"/> <input type="checkbox"/> <input type="checkbox"/> <input type="checkbox"/>	64.00#	1704	1738	1772	1789	1858	
	TFSFP6648	<input type="checkbox"/> <input type="checkbox"/> <input type="checkbox"/> <input type="checkbox"/>	<input type="checkbox"/>	<input type="checkbox"/>	<input type="checkbox"/> <input type="checkbox"/> <input type="checkbox"/> <input type="checkbox"/>	67.00#	1870	1906	1945	1963	2038	
	TFSFP7248	<input type="checkbox"/> <input type="checkbox"/> <input type="checkbox"/> <input type="checkbox"/>	<input type="checkbox"/>	<input type="checkbox"/>	<input type="checkbox"/> <input type="checkbox"/> <input type="checkbox"/> <input type="checkbox"/>	71.00#	1963	2002	2040	2061	2139	
	TFSFP7848	<input type="checkbox"/> <input type="checkbox"/> <input type="checkbox"/> <input type="checkbox"/>	<input type="checkbox"/>	<input type="checkbox"/>	<input type="checkbox"/> <input type="checkbox"/> <input type="checkbox"/> <input type="checkbox"/>	75.00#	2028	2067	2108	2129	2210	
	TFSFP8448	<input type="checkbox"/> <input type="checkbox"/> <input type="checkbox"/> <input type="checkbox"/>	<input type="checkbox"/>	<input type="checkbox"/>	<input type="checkbox"/> <input type="checkbox"/> <input type="checkbox"/> <input type="checkbox"/>	81.00#	2078	2119	2161	2183	2266	
	TFSFP9048	<input type="checkbox"/> <input type="checkbox"/> <input type="checkbox"/> <input type="checkbox"/>	<input type="checkbox"/>	<input type="checkbox"/>	<input type="checkbox"/> <input type="checkbox"/> <input type="checkbox"/> <input type="checkbox"/>	82.00#	2122	2165	2207	2228	2315	
	TFSFP9648	<input type="checkbox"/> <input type="checkbox"/> <input type="checkbox"/> <input type="checkbox"/>	<input type="checkbox"/>	<input type="checkbox"/>	<input type="checkbox"/> <input type="checkbox"/> <input type="checkbox"/> <input type="checkbox"/>	85.00#	2189	2234	2276	2298	2386	
TFSFP	<p>Segmented Flex Screen with Fabric Lower, Fluted Polycarbonate Upper Core - 54" H</p> <ul style="list-style-type: none"> Flex screen assembly includes aluminum powder-coated frame, core material, all trim, and feet Upper segment features non-magnetic semi-transparent fluted polycarbonate Lower segment features identical tackable fabric core on both sides, fabric pattern is railroaded Specify adjustable glide feet or non-adjustable flat/bridge feet Non-powered; no wire management Fully assembled; includes all trim Slotting under upper trim accepts screen-hung accessories Segmentation at 29" Elevated base does not accept power Fluting runs horizontal 	TFSFP4254	<input type="checkbox"/> <input type="checkbox"/> <input type="checkbox"/> <input type="checkbox"/>	<input type="checkbox"/>	<input type="checkbox"/>	<input type="checkbox"/> <input type="checkbox"/> <input type="checkbox"/> <input type="checkbox"/>	57.00#	\$ 1470	\$ 1499	\$ 1528	\$ 1544	\$ 1602
		TFSFP4854	<input type="checkbox"/> <input type="checkbox"/> <input type="checkbox"/> <input type="checkbox"/>	<input type="checkbox"/>	<input type="checkbox"/>	<input type="checkbox"/> <input type="checkbox"/> <input type="checkbox"/> <input type="checkbox"/>	61.00#	1559	1589	1620	1634	1699
		TFSFP5454	<input type="checkbox"/> <input type="checkbox"/> <input type="checkbox"/> <input type="checkbox"/>	<input type="checkbox"/>	<input type="checkbox"/>	<input type="checkbox"/> <input type="checkbox"/> <input type="checkbox"/> <input type="checkbox"/>	65.00#	1651	1685	1717	1733	1801
		TFSFP6054	<input type="checkbox"/> <input type="checkbox"/> <input type="checkbox"/> <input type="checkbox"/>	<input type="checkbox"/>	<input type="checkbox"/>	<input type="checkbox"/> <input type="checkbox"/> <input type="checkbox"/> <input type="checkbox"/>	69.00#	1746	1780	1815	1833	1903
		TFSFP6654	<input type="checkbox"/> <input type="checkbox"/> <input type="checkbox"/> <input type="checkbox"/>	<input type="checkbox"/>	<input type="checkbox"/>	<input type="checkbox"/> <input type="checkbox"/> <input type="checkbox"/> <input type="checkbox"/>	73.00#	1913	1949	1988	2007	2085
		TFSFP7254	<input type="checkbox"/> <input type="checkbox"/> <input type="checkbox"/> <input type="checkbox"/>	<input type="checkbox"/>	<input type="checkbox"/>	<input type="checkbox"/> <input type="checkbox"/> <input type="checkbox"/> <input type="checkbox"/>	77.00#	2006	2045	2086	2106	2186
		TFSFP7854	<input type="checkbox"/> <input type="checkbox"/> <input type="checkbox"/> <input type="checkbox"/>	<input type="checkbox"/>	<input type="checkbox"/>	<input type="checkbox"/> <input type="checkbox"/> <input type="checkbox"/> <input type="checkbox"/>	79.00#	2073	2113	2154	2174	2258
		TFSFP8454	<input type="checkbox"/> <input type="checkbox"/> <input type="checkbox"/> <input type="checkbox"/>	<input type="checkbox"/>	<input type="checkbox"/>	<input type="checkbox"/> <input type="checkbox"/> <input type="checkbox"/> <input type="checkbox"/>	81.00#	2122	2165	2207	2228	2315
		TFSFP9054	<input type="checkbox"/> <input type="checkbox"/> <input type="checkbox"/> <input type="checkbox"/>	<input type="checkbox"/>	<input type="checkbox"/>	<input type="checkbox"/> <input type="checkbox"/> <input type="checkbox"/> <input type="checkbox"/>	89.00#	2168	2211	2254	2276	2363
		TFSFP9654	<input type="checkbox"/> <input type="checkbox"/> <input type="checkbox"/> <input type="checkbox"/>	<input type="checkbox"/>	<input type="checkbox"/>	<input type="checkbox"/> <input type="checkbox"/> <input type="checkbox"/> <input type="checkbox"/>	93.00#	2235	2279	2323	2347	2436

A **B** **C** **D** **E**

HOW TO ORDER

- Indicate the following information on order form:
- Quantity of each item.
 - Model number, including options. See "How To Build a Model Number".
 - Any special service required.

Note: • The indicates that a choice is required.

- The absence of the indicates that no choice is required.
- Alpha-numeric characters in place of indicate that no other alternatives are available.

HOW TO BUILD A MODEL NUMBER

- A** Select basic model.
- B** Select foot option.

FADJ	- Adjustable
FFLB	- Flat/Bridge
- C** Select top cap style.

F	- Flat aluminum top cap (standard)
N	- No top cap (specify for use with toppers)
- D** Select frame/trim color. Refer to the **Product Color Options** page in this price list.
- E** Select lower fabric color. Refer to ki.com/fabrics

INFORMATION

COM YARDAGE REQUIREMENTS

Screen Width/Length	Fabric Required
42	2.556
48	2.889
54	3.222
60	3.556
66	3.889
72	4.222
78	4.556
84	4.889
90	5.222
96	5.556

SPECIAL SERVICES

Special Carton Marking

With specially marked information N/C

Shipping

Ships assembled, FOB Manitowoc, WI 54220, freight prepaid. Freight class 70.

Specifications and prices are subject to change without prior notice.

Tattoo™ Flex Screens

Segmented Flex Screen with Fabric Lower, Fluted Polycarbonate Upper Core



Tattoo™ Flex Screens

Segmented Flex Screen with Fabric Lower, Fluted Polycarbonate Upper Core

MODEL	MODEL NUMBER					Approx. Packaged Weight	Delivered Pricing Fabric Grade 1 & C.O.M.	Delivered Pricing Fabric Grade 2	Delivered Pricing Fabric Grade 3 & Pallas Vertical Fabric Grade PV	Delivered Pricing Pallas Vertical Fabric Grade PV1	Delivered Pricing Pallas Vertical Fabric Grade PV2
	Basic Model	Foot Option	Top Cap Style	Frame/Trim Color	Lower Fabric Color						
TFSFP Segmented Flex Screen with Fabric Lower, Fluted Polycarbonate Upper Core - 60" H <ul style="list-style-type: none"> Flex screen assembly includes aluminum powder-coated frame, core material, all trim, and feet Upper segment features non-magnetic semi-transparent fluted polycarbonate Lower segment features identical tackable fabric core on both sides, fabric pattern is railroaded Specify adjustable glide feet or non-adjustable flat/bridge feet Non-powered; no wire management Fully assembled; includes all trim Slotting under upper trim accepts screen-hung accessories Segmentation at 29" Elevated base does not accept power Fluting runs horizontal 	TFSFP4260	<input type="checkbox"/> <input type="checkbox"/> <input type="checkbox"/> <input type="checkbox"/>	<input type="checkbox"/>	<input type="checkbox"/> <input type="checkbox"/>	<input type="checkbox"/> <input type="checkbox"/> <input type="checkbox"/> <input type="checkbox"/>	61.00#	\$ 1603	\$ 1635	\$ 1667	\$ 1684	\$ 1749
	TFSFP4860	<input type="checkbox"/> <input type="checkbox"/> <input type="checkbox"/> <input type="checkbox"/>	<input type="checkbox"/>	<input type="checkbox"/> <input type="checkbox"/>	<input type="checkbox"/> <input type="checkbox"/> <input type="checkbox"/> <input type="checkbox"/>	65.00#	1696	1730	1763	1781	1848
	TFSFP5460	<input type="checkbox"/> <input type="checkbox"/> <input type="checkbox"/> <input type="checkbox"/>	<input type="checkbox"/>	<input type="checkbox"/> <input type="checkbox"/>	<input type="checkbox"/> <input type="checkbox"/> <input type="checkbox"/> <input type="checkbox"/>	70.00#	1791	1825	1862	1879	1952
	TFSFP6060	<input type="checkbox"/> <input type="checkbox"/> <input type="checkbox"/> <input type="checkbox"/>	<input type="checkbox"/>	<input type="checkbox"/> <input type="checkbox"/>	<input type="checkbox"/> <input type="checkbox"/> <input type="checkbox"/> <input type="checkbox"/>	74.00#	1886	1922	1959	1978	2054
	TFSFP6660	<input type="checkbox"/> <input type="checkbox"/> <input type="checkbox"/> <input type="checkbox"/>	<input type="checkbox"/>	<input type="checkbox"/> <input type="checkbox"/>	<input type="checkbox"/> <input type="checkbox"/> <input type="checkbox"/> <input type="checkbox"/>	79.00#	2052	2092	2135	2154	2236
	TFSFP7260	<input type="checkbox"/> <input type="checkbox"/> <input type="checkbox"/> <input type="checkbox"/>	<input type="checkbox"/>	<input type="checkbox"/> <input type="checkbox"/>	<input type="checkbox"/> <input type="checkbox"/> <input type="checkbox"/> <input type="checkbox"/>	83.00#	2146	2189	2232	2253	2337
	TFSFP7860	<input type="checkbox"/> <input type="checkbox"/> <input type="checkbox"/> <input type="checkbox"/>	<input type="checkbox"/>	<input type="checkbox"/> <input type="checkbox"/>	<input type="checkbox"/> <input type="checkbox"/> <input type="checkbox"/> <input type="checkbox"/>	88.00#	2214	2257	2302	2323	2411
	TFSFP8460	<input type="checkbox"/> <input type="checkbox"/> <input type="checkbox"/> <input type="checkbox"/>	<input type="checkbox"/>	<input type="checkbox"/> <input type="checkbox"/>	<input type="checkbox"/> <input type="checkbox"/> <input type="checkbox"/> <input type="checkbox"/>	92.00#	2265	2309	2354	2378	2468
	TFSFP9060	<input type="checkbox"/> <input type="checkbox"/> <input type="checkbox"/> <input type="checkbox"/>	<input type="checkbox"/>	<input type="checkbox"/> <input type="checkbox"/>	<input type="checkbox"/> <input type="checkbox"/> <input type="checkbox"/> <input type="checkbox"/>	97.00#	2309	2356	2404	2427	2518
	TFSFP9660	<input type="checkbox"/> <input type="checkbox"/> <input type="checkbox"/> <input type="checkbox"/>	<input type="checkbox"/>	<input type="checkbox"/> <input type="checkbox"/>	<input type="checkbox"/> <input type="checkbox"/> <input type="checkbox"/> <input type="checkbox"/>	101.00#	2378	2426	2472	2496	2592

A **B** **C** **D** **E**

HOW TO ORDER

- Indicate the following information on order form:
- Quantity of each item.
 - Model number, including options. See "How To Build a Model Number".
 - Any special service required.

Note:

- The indicates that a choice is required.
- The absence of the indicates that no choice is required.
- Alpha-numeric characters in place of indicate that no other alternatives are available.

HOW TO BUILD A MODEL NUMBER

- A** Select basic model.
- B** Select foot option.

FADJ	- Adjustable
FFLB	- Flat/Bridge
- C** Select top cap style.

F	- Flat aluminum top cap (standard)
N	- No top cap (specify for use with toppers)
- D** Select frame/trim color.
Refer to the **Product Color Options** page in this price list.
- E** Select lower fabric color.
Refer to ki.com/fabrics

INFORMATION

COM YARDAGE REQUIREMENTS

Screen Width/Length	Fabric Required
42	2.556
48	2.889
54	3.222
60	3.556
66	3.889
72	4.222
78	4.556
84	4.889
90	5.222
96	5.556

SPECIAL SERVICES

Special Carton Marking

With specially marked information N/C

Shipping

Ships **assembled, FOB Manitowoc, WI 54220, freight prepaid.** Freight class 70.

Specifications and prices are subject to change without prior notice.

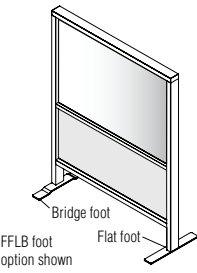

MODEL	MODEL NUMBER						Approx. Packaged Weight	Delivered Pricing Fabric Grade 1 & C.O.M.	Delivered Pricing Fabric Grade 2	Delivered Pricing Fabric Grade 3 & Pallas Vertical Fabric Grade PV	Delivered Pricing Pallas Vertical Fabric Grade PV1	Delivered Pricing Pallas Vertical Fabric Grade PV2
	Basic Model	Foot Option	Top Cap Style	Frame/Trim Color	Lower Fabric Color	Upper Acrylic Finish						
 <p>Segmented Flex Screen with Fabric Lower, Acrylic Upper Core - 48" H</p> <ul style="list-style-type: none"> Flex screen assembly includes aluminum powder-coated frame, core material, all trim, and feet Upper segment features non-magnetic translucent acrylic core Lower segment features identical tackable fabric core on both sides, fabric pattern is railroaded Specify adjustable glide feet or non-adjustable flat/bridge feet Non-powered; no wire management Fully assembled; includes all trim Slotting under upper trim accepts screen-hung accessories Segmentation at 29" Elevated base does not accept power 	TFSFA4248	<input type="checkbox"/> <input type="checkbox"/> <input type="checkbox"/> <input type="checkbox"/>	<input type="checkbox"/>	<input type="checkbox"/>	<input type="checkbox"/> <input type="checkbox"/> <input type="checkbox"/> <input type="checkbox"/> <input type="checkbox"/> <input type="checkbox"/>	<input type="checkbox"/> <input type="checkbox"/>	72.00#	\$ 1519	\$ 1549	\$ 1580	\$ 1595	\$ 1657
	TFSFA4848	<input type="checkbox"/> <input type="checkbox"/> <input type="checkbox"/> <input type="checkbox"/>	<input type="checkbox"/>	<input type="checkbox"/>	<input type="checkbox"/> <input type="checkbox"/> <input type="checkbox"/> <input type="checkbox"/> <input type="checkbox"/> <input type="checkbox"/>	<input type="checkbox"/> <input type="checkbox"/>	78.00#	1613	1645	1677	1694	1757
	TFSFA5448	<input type="checkbox"/> <input type="checkbox"/> <input type="checkbox"/> <input type="checkbox"/>	<input type="checkbox"/>	<input type="checkbox"/>	<input type="checkbox"/> <input type="checkbox"/> <input type="checkbox"/> <input type="checkbox"/> <input type="checkbox"/> <input type="checkbox"/>	<input type="checkbox"/> <input type="checkbox"/>	84.00#	1717	1751	1787	1804	1872
	TFSFA6048	<input type="checkbox"/> <input type="checkbox"/> <input type="checkbox"/> <input type="checkbox"/>	<input type="checkbox"/>	<input type="checkbox"/>	<input type="checkbox"/> <input type="checkbox"/> <input type="checkbox"/> <input type="checkbox"/> <input type="checkbox"/> <input type="checkbox"/>	<input type="checkbox"/> <input type="checkbox"/>	90.00#	1787	1821	1859	1875	1947
	TFSFA6648	<input type="checkbox"/> <input type="checkbox"/> <input type="checkbox"/> <input type="checkbox"/>	<input type="checkbox"/>	<input type="checkbox"/>	<input type="checkbox"/> <input type="checkbox"/> <input type="checkbox"/> <input type="checkbox"/> <input type="checkbox"/> <input type="checkbox"/>	<input type="checkbox"/> <input type="checkbox"/>	96.00#	1975	2013	2054	2074	2153
	TFSFA7248	<input type="checkbox"/> <input type="checkbox"/> <input type="checkbox"/> <input type="checkbox"/>	<input type="checkbox"/>	<input type="checkbox"/>	<input type="checkbox"/> <input type="checkbox"/> <input type="checkbox"/> <input type="checkbox"/> <input type="checkbox"/> <input type="checkbox"/>	<input type="checkbox"/> <input type="checkbox"/>	102.00#	2107	2149	2191	2214	2297
	TFSFA7848	<input type="checkbox"/> <input type="checkbox"/> <input type="checkbox"/> <input type="checkbox"/>	<input type="checkbox"/>	<input type="checkbox"/>	<input type="checkbox"/> <input type="checkbox"/> <input type="checkbox"/> <input type="checkbox"/> <input type="checkbox"/> <input type="checkbox"/>	<input type="checkbox"/> <input type="checkbox"/>	108.00#	2149	2191	2235	2256	2343
	TFSFA8448	<input type="checkbox"/> <input type="checkbox"/> <input type="checkbox"/> <input type="checkbox"/>	<input type="checkbox"/>	<input type="checkbox"/>	<input type="checkbox"/> <input type="checkbox"/> <input type="checkbox"/> <input type="checkbox"/> <input type="checkbox"/> <input type="checkbox"/>	<input type="checkbox"/> <input type="checkbox"/>	114.00#	2396	2443	2492	2515	2610
	TFSFA9048	<input type="checkbox"/> <input type="checkbox"/> <input type="checkbox"/> <input type="checkbox"/>	<input type="checkbox"/>	<input type="checkbox"/>	<input type="checkbox"/> <input type="checkbox"/> <input type="checkbox"/> <input type="checkbox"/> <input type="checkbox"/> <input type="checkbox"/>	<input type="checkbox"/> <input type="checkbox"/>	120.00#	2417	2465	2514	2537	2634
	TFSFA9648	<input type="checkbox"/> <input type="checkbox"/> <input type="checkbox"/> <input type="checkbox"/>	<input type="checkbox"/>	<input type="checkbox"/>	<input type="checkbox"/> <input type="checkbox"/> <input type="checkbox"/> <input type="checkbox"/> <input type="checkbox"/> <input type="checkbox"/>	<input type="checkbox"/> <input type="checkbox"/>	126.00#	2460	2509	2559	2581	2680
<p>Segmented Flex Screen with Fabric Lower, Acrylic Upper Core - 54" H</p> <ul style="list-style-type: none"> Flex screen assembly includes aluminum powder-coated frame, core material, all trim, and feet Upper segment features non-magnetic translucent acrylic core Lower segment features identical tackable fabric core on both sides, fabric pattern is railroaded Specify adjustable glide feet or non-adjustable flat/bridge feet Non-powered; no wire management Fully assembled; includes all trim Slotting under upper trim accepts screen-hung accessories Segmentation at 29" Elevated base does not accept power 	TFSFA4254	<input type="checkbox"/> <input type="checkbox"/> <input type="checkbox"/> <input type="checkbox"/>	<input type="checkbox"/>	<input type="checkbox"/>	<input type="checkbox"/> <input type="checkbox"/> <input type="checkbox"/> <input type="checkbox"/> <input type="checkbox"/> <input type="checkbox"/>	<input type="checkbox"/> <input type="checkbox"/>	78.00#	\$ 1627	\$ 1659	\$ 1692	\$ 1708	\$ 1774
	TFSFA4854	<input type="checkbox"/> <input type="checkbox"/> <input type="checkbox"/> <input type="checkbox"/>	<input type="checkbox"/>	<input type="checkbox"/>	<input type="checkbox"/> <input type="checkbox"/> <input type="checkbox"/> <input type="checkbox"/> <input type="checkbox"/> <input type="checkbox"/>	<input type="checkbox"/> <input type="checkbox"/>	84.00#	1757	1792	1828	1845	1915
	TFSFA5454	<input type="checkbox"/> <input type="checkbox"/> <input type="checkbox"/> <input type="checkbox"/>	<input type="checkbox"/>	<input type="checkbox"/>	<input type="checkbox"/> <input type="checkbox"/> <input type="checkbox"/> <input type="checkbox"/> <input type="checkbox"/> <input type="checkbox"/>	<input type="checkbox"/> <input type="checkbox"/>	91.00#	1891	1928	1966	1986	2061
	TFSFA6054	<input type="checkbox"/> <input type="checkbox"/> <input type="checkbox"/> <input type="checkbox"/>	<input type="checkbox"/>	<input type="checkbox"/>	<input type="checkbox"/> <input type="checkbox"/> <input type="checkbox"/> <input type="checkbox"/> <input type="checkbox"/> <input type="checkbox"/>	<input type="checkbox"/> <input type="checkbox"/>	102.00#	1960	2001	2039	2059	2137
	TFSFA6654	<input type="checkbox"/> <input type="checkbox"/> <input type="checkbox"/> <input type="checkbox"/>	<input type="checkbox"/>	<input type="checkbox"/>	<input type="checkbox"/> <input type="checkbox"/> <input type="checkbox"/> <input type="checkbox"/> <input type="checkbox"/> <input type="checkbox"/>	<input type="checkbox"/> <input type="checkbox"/>	107.00#	2193	2237	2146	2303	2390
	TFSFA7254	<input type="checkbox"/> <input type="checkbox"/> <input type="checkbox"/> <input type="checkbox"/>	<input type="checkbox"/>	<input type="checkbox"/>	<input type="checkbox"/> <input type="checkbox"/> <input type="checkbox"/> <input type="checkbox"/> <input type="checkbox"/> <input type="checkbox"/>	<input type="checkbox"/> <input type="checkbox"/>	111.00#	2265	2308	2354	2377	2466
	TFSFA7854	<input type="checkbox"/> <input type="checkbox"/> <input type="checkbox"/> <input type="checkbox"/>	<input type="checkbox"/>	<input type="checkbox"/>	<input type="checkbox"/> <input type="checkbox"/> <input type="checkbox"/> <input type="checkbox"/> <input type="checkbox"/> <input type="checkbox"/>	<input type="checkbox"/> <input type="checkbox"/>	118.00#	2443	2492	2539	2565	2662
	TFSFA8454	<input type="checkbox"/> <input type="checkbox"/> <input type="checkbox"/> <input type="checkbox"/>	<input type="checkbox"/>	<input type="checkbox"/>	<input type="checkbox"/> <input type="checkbox"/> <input type="checkbox"/> <input type="checkbox"/> <input type="checkbox"/> <input type="checkbox"/>	<input type="checkbox"/> <input type="checkbox"/>	125.00#	2697	2738	2805	2831	2939
	TFSFA9054	<input type="checkbox"/> <input type="checkbox"/> <input type="checkbox"/> <input type="checkbox"/>	<input type="checkbox"/>	<input type="checkbox"/>	<input type="checkbox"/> <input type="checkbox"/> <input type="checkbox"/> <input type="checkbox"/> <input type="checkbox"/> <input type="checkbox"/>	<input type="checkbox"/> <input type="checkbox"/>	132.00#	2721	2775	2829	2856	2964
	TFSFA9654	<input type="checkbox"/> <input type="checkbox"/> <input type="checkbox"/> <input type="checkbox"/>	<input type="checkbox"/>	<input type="checkbox"/>	<input type="checkbox"/> <input type="checkbox"/> <input type="checkbox"/> <input type="checkbox"/> <input type="checkbox"/> <input type="checkbox"/>	<input type="checkbox"/> <input type="checkbox"/>	138.00#	2763	2818	2874	2902	3011

A **B** **C** **D** **E** **F**

HOW TO ORDER

- Indicate the following information on order form:
- Quantity of each item.
 - Model number, including options. See "How To Build a Model Number".
 - Any special service required.

Note: • The indicates that a choice is required.
 • The absence of the indicates that no choice is required.
 • Alpha-numeric characters in place of indicate that no other alternatives are available.

HOW TO BUILD A MODEL NUMBER

- A** Select basic model.
- B** Select foot option.

FADJ	- Adjustable
FFLB	- Flat/Bridge
- C** Select top cap style.

F	- Flat aluminum top cap (standard)
N	- No top cap (specify for use with toppers)
- D** Select frame/trim color. Refer to the **Product Color Options** page in this price list.
- E** Select lower fabric color. Refer to ki.com/fabrics
- F** Select upper acrylic finish. Refer to the **Product Color Options** page in this price list.

INFORMATION

COM YARDAGE REQUIREMENTS

Screen Width/Length	Fabric Required
42	2.556
48	2.889
54	3.222
60	3.556
66	3.889
72	4.222
78	4.556
84	4.889
90	5.222
96	5.556

SPECIAL SERVICES

Special Carton Marking
 With specially marked information N/C

Shipping
 Ships assembled, FOB Manitowoc, WI 54220, freight prepaid. Freight class 70.

Specifications and prices are subject to change without prior notice.



MODEL	MODEL NUMBER						Approx. Packaged Weight	Delivered Pricing Fabric Grade 1 & C.O.M.	Delivered Pricing Fabric Grade 2	Delivered Pricing Fabric Grade 3 & Pallas Vertical Fabric Grade PV	Delivered Pricing Pallas Vertical Fabric Grade PV1	Delivered Pricing Pallas Vertical Fabric Grade PV2
	Basic Model	Foot Option	Top Cap Style	Frame/Trim Color	Lower Fabric Color	Upper Acrylic Finish						
TFSFA Segmented Flex Screen with Fabric Lower, Acrylic Upper Core - 60" H <ul style="list-style-type: none"> Flex screen assembly includes aluminum powder-coated frame, core material, all trim, and feet Upper segment features non-magnetic translucent acrylic core Lower segment features identical tackable fabric core on both sides, fabric pattern is railroaded Specify adjustable glide feet or non-adjustable flat/bridge feet Non-powered; no wire management Fully assembled; includes all trim Slotting under upper trim accepts screen-hung accessories Segmentation at 29" Elevated base does not accept power 	TFSFA4260	<input type="checkbox"/> <input type="checkbox"/> <input type="checkbox"/> <input type="checkbox"/>	<input type="checkbox"/>	<input type="checkbox"/> <input type="checkbox"/>	<input type="checkbox"/> <input type="checkbox"/> <input type="checkbox"/> <input type="checkbox"/>	<input type="checkbox"/> <input type="checkbox"/>	83.00#	\$ 1992	\$ 2031	\$ 2073	\$ 2092	\$ 2171
	TFSFA4860	<input type="checkbox"/> <input type="checkbox"/> <input type="checkbox"/> <input type="checkbox"/>	<input type="checkbox"/>	<input type="checkbox"/> <input type="checkbox"/>	<input type="checkbox"/> <input type="checkbox"/> <input type="checkbox"/> <input type="checkbox"/>	<input type="checkbox"/> <input type="checkbox"/>	90.00#	2063	2105	2146	2167	2249
	TFSFA5460	<input type="checkbox"/> <input type="checkbox"/> <input type="checkbox"/> <input type="checkbox"/>	<input type="checkbox"/>	<input type="checkbox"/> <input type="checkbox"/>	<input type="checkbox"/> <input type="checkbox"/> <input type="checkbox"/> <input type="checkbox"/>	<input type="checkbox"/> <input type="checkbox"/>	102.00#	2272	2319	2363	2386	2477
	TFSFA6060	<input type="checkbox"/> <input type="checkbox"/> <input type="checkbox"/> <input type="checkbox"/>	<input type="checkbox"/>	<input type="checkbox"/> <input type="checkbox"/>	<input type="checkbox"/> <input type="checkbox"/> <input type="checkbox"/> <input type="checkbox"/>	<input type="checkbox"/> <input type="checkbox"/>	110.00#	2345	2390	2437	2462	2554
	TFSFA6660	<input type="checkbox"/> <input type="checkbox"/> <input type="checkbox"/> <input type="checkbox"/>	<input type="checkbox"/>	<input type="checkbox"/> <input type="checkbox"/>	<input type="checkbox"/> <input type="checkbox"/> <input type="checkbox"/> <input type="checkbox"/>	<input type="checkbox"/> <input type="checkbox"/>	115.00#	2718	2773	2829	2856	2964
	TFSFA7260	<input type="checkbox"/> <input type="checkbox"/> <input type="checkbox"/> <input type="checkbox"/>	<input type="checkbox"/>	<input type="checkbox"/> <input type="checkbox"/>	<input type="checkbox"/> <input type="checkbox"/> <input type="checkbox"/> <input type="checkbox"/>	<input type="checkbox"/> <input type="checkbox"/>	120.00#	2791	2847	2903	2931	3041
	TFSFA7860	<input type="checkbox"/> <input type="checkbox"/> <input type="checkbox"/> <input type="checkbox"/>	<input type="checkbox"/>	<input type="checkbox"/> <input type="checkbox"/>	<input type="checkbox"/> <input type="checkbox"/> <input type="checkbox"/> <input type="checkbox"/>	<input type="checkbox"/> <input type="checkbox"/>	128.00#	2836	2892	2948	2977	3091
	TFSFA8460	<input type="checkbox"/> <input type="checkbox"/> <input type="checkbox"/> <input type="checkbox"/>	<input type="checkbox"/>	<input type="checkbox"/> <input type="checkbox"/>	<input type="checkbox"/> <input type="checkbox"/> <input type="checkbox"/> <input type="checkbox"/>	<input type="checkbox"/> <input type="checkbox"/>	135.00#	3331	3398	3464	3496	3631
	TFSFA9060	<input type="checkbox"/> <input type="checkbox"/> <input type="checkbox"/> <input type="checkbox"/>	<input type="checkbox"/>	<input type="checkbox"/> <input type="checkbox"/>	<input type="checkbox"/> <input type="checkbox"/> <input type="checkbox"/> <input type="checkbox"/>	<input type="checkbox"/> <input type="checkbox"/>	143.00#	3355	3421	3491	3524	3657
	TFSFA9660	<input type="checkbox"/> <input type="checkbox"/> <input type="checkbox"/> <input type="checkbox"/>	<input type="checkbox"/>	<input type="checkbox"/> <input type="checkbox"/>	<input type="checkbox"/> <input type="checkbox"/> <input type="checkbox"/> <input type="checkbox"/>	<input type="checkbox"/> <input type="checkbox"/>	150.00#	3403	3469	3537	3570	3708

A **B** **C** **D** **E** **F**

HOW TO ORDER

- Indicate the following information on order form:
- Quantity of each item.
 - Model number, including options. See "How To Build a Model Number".
 - Any special service required.

Note:

- The indicates that a choice is required.
- The absence of the indicates that no choice is required.
- Alpha-numeric characters in place of indicate that no other alternatives are available.

HOW TO BUILD A MODEL NUMBER

- A** Select basic model.
- B** Select foot option.

FADJ	- Adjustable
FFLB	- Flat/Bridge
- C** Select top cap style.

F	- Flat aluminum top cap (standard)
N	- No top cap (specify for use with toppers)
- D** Select frame/trim color. Refer to the **Product Color Options** page in this price list.
- E** Select lower fabric color. Refer to ki.com/fabrics
- F** Select upper acrylic finish. Refer to the **Product Color Options** page in this price list.

INFORMATION

COM YARDAGE REQUIREMENTS

Screen Width/Length	Fabric Required
42	2.556
48	2.889
54	3.222
60	3.556
66	3.889
72	4.222
78	4.556
84	4.889
90	5.222
96	5.556

SPECIAL SERVICES

Special Carton Marking

With specially marked information N/C

Shipping
Ships **assembled, FOB Manitowoc, WI 54220, freight prepaid.** Freight class 70.

Specifications and prices are subject to change without prior notice.

Tattoo™ Spine Screens

Powered Monolithic Spine Screen with Magnetic Dry-Erasable Steel Core



Tattoo™ Spine Screens

Powered Monolithic Spine Screen with Magnetic Dry-Erasable Steel Core

MODEL	MODEL NUMBER					Approx. Packaged Weight	Delivered Pricing
	Basic Model	Power Option	Bezel Color	Top Cap Style	Frame Color		
Powered Monolithic Spine Screen with Magnetic Dry-Erasable Steel Core - 48" H <ul style="list-style-type: none"> Spine screens support straight-line power planning only Spine screen assembly includes powder-coated aluminum frame, core material, adjustable foot base, raceway cover with two power cutouts/bezels, and one data cutout (when specified) Frame ships with top cap. Specify "no top cap" with accessory toppers. Vertical trim is specified separately Steel core is dry-erasable and magnetic Standard base raceway on both sides accepts power and data cable distribution Ships assembled, except for feet which require on site attachment Slotting under upper trim accepts screen-hung accessories Standard power option includes two 10-wire rigid wireways with in-line connecting jumper. Rigid wireways are factory assembled and attached. Receptacles, infeeds, and screen-to-screen jumpers are specified separately Hardwired (Chicago) power option includes 2"x3" conventional outlet boxes factory mounted with brackets to the underside of the screen. All other electrical fittings, wires, receptacles, and face plates are provided by electrician Optional data cutouts are sized 2.88 x 1.82" with two drill holes to accommodate a #6-32 screw. Requires a 45 degree angled wall plate (not supplied) May not be used as a freestanding screen on its own. Must be mechanically attached to another Spine Screen (with or without electrical) 	TSSPE4848	<input type="checkbox"/> <input type="checkbox"/> <input type="checkbox"/> <input type="checkbox"/>	<input type="checkbox"/> <input type="checkbox"/> <input type="checkbox"/>	<input type="checkbox"/>	<input type="checkbox"/>	93.00#	\$ 2077
	TSSPE5448	<input type="checkbox"/> <input type="checkbox"/> <input type="checkbox"/> <input type="checkbox"/>	<input type="checkbox"/> <input type="checkbox"/> <input type="checkbox"/>	<input type="checkbox"/>	<input type="checkbox"/>	101.00#	2275
	TSSPE6048	<input type="checkbox"/> <input type="checkbox"/> <input type="checkbox"/> <input type="checkbox"/>	<input type="checkbox"/> <input type="checkbox"/> <input type="checkbox"/>	<input type="checkbox"/>	<input type="checkbox"/>	109.00#	2363
	TSSPE6648	<input type="checkbox"/> <input type="checkbox"/> <input type="checkbox"/> <input type="checkbox"/>	<input type="checkbox"/> <input type="checkbox"/> <input type="checkbox"/>	<input type="checkbox"/>	<input type="checkbox"/>	117.00#	2560
	TSSPE7248	<input type="checkbox"/> <input type="checkbox"/> <input type="checkbox"/> <input type="checkbox"/>	<input type="checkbox"/> <input type="checkbox"/> <input type="checkbox"/>	<input type="checkbox"/>	<input type="checkbox"/>	125.00#	2648
	TSSPE7848	<input type="checkbox"/> <input type="checkbox"/> <input type="checkbox"/> <input type="checkbox"/>	<input type="checkbox"/> <input type="checkbox"/> <input type="checkbox"/>	<input type="checkbox"/>	<input type="checkbox"/>	133.00#	2795
	TSSPE8448	<input type="checkbox"/> <input type="checkbox"/> <input type="checkbox"/> <input type="checkbox"/>	<input type="checkbox"/> <input type="checkbox"/> <input type="checkbox"/>	<input type="checkbox"/>	<input type="checkbox"/>	141.00#	2837
	TSSPE9048	<input type="checkbox"/> <input type="checkbox"/> <input type="checkbox"/> <input type="checkbox"/>	<input type="checkbox"/> <input type="checkbox"/> <input type="checkbox"/>	<input type="checkbox"/>	<input type="checkbox"/>	149.00#	2985
	TSSPE9648	<input type="checkbox"/> <input type="checkbox"/> <input type="checkbox"/> <input type="checkbox"/>	<input type="checkbox"/> <input type="checkbox"/> <input type="checkbox"/>	<input type="checkbox"/>	<input type="checkbox"/>	157.00#	3024

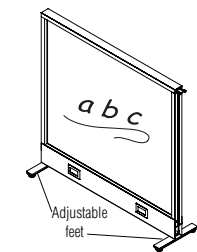

TSSPE

A **B** **C** **D** **E**

HOW TO ORDER

- Indicate the following information on order form:
- Quantity of each item.
 - Model number, including options. See "How To Build a Model Number".
 - Any special service required.

Note:

- The indicates that a choice is required.
- The absence of the indicates that no choice is required.
- Alpha-numeric characters in place of indicate that no other alternatives are available.

HOW TO BUILD A MODEL NUMBER

- A** Select basic model.
- B** Select power option.
 - 1P** - 10-Wire power cutouts on 1 side only/no cutouts side 2
 - DP** - 10-Wire power cutouts only both sides
 - 2D** - 10-Wire power cutouts both sides/data cutouts on 1 side only
 - 1D** - 10-Wire power w/data cutouts on 1 side only/no cutouts side 2
 - DD** - 10-Wire power w/data cutouts both sides
 - CP** - Hardwired/Chicago power cutouts only both sides
 - CD** - Hardwired/Chicago power w/data cutouts both sides
- C** Select bezel color. Refer to the **Product Color Options** page in this price list.
- D** Select top cap style.
 - F** - Flat aluminum top cap (standard)
 - N** - No top cap (specify for use with toppers)
- E** Select frame color. Refer to the **Product Color Options** page in this price list.

SPECIAL SERVICES

Special Carton Marking
 With specially marked information N/C

Shipping
 Ships assembled, FOB Manitowoc, WI 54220, freight prepaid. Freight class 70.

Specifications and prices are subject to change without prior notice.

Tattoo™ Spine Screens

Powered Monolithic Spine Screen with Magnetic Dry-Erasable Steel Core



Tattoo™ Spine Screens

Powered Monolithic Spine Screen with Magnetic Dry-Erasable Steel Core

MODEL	MODEL NUMBER					Approx. Packaged Weight	Delivered Pricing
	Basic Model	Power Option	Bezel Color	Top Cap Style	Frame Color		
TSSPE Powered Monolithic Spine Screen with Magnetic Dry-Erasable Steel Core - 54" H <ul style="list-style-type: none"> Spine screens support straight-line power planning only Spine screen assembly includes powder-coated aluminum frame, core material, adjustable foot base, raceway cover with two power cutouts/bezels, and one data cutout (when specified) Frame ships with top cap. Specify "no top cap" with accessory toppers. Vertical trim is specified separately Steel core is dry-erasable and magnetic Standard base raceway on both sides accepts power and data cable distribution Ships assembled, except for feet which require on site attachment Slotting under upper trim accepts screen-hung accessories Standard power option includes two 10-wire rigid wireways with in-line connecting jumper. Rigid wireways are factory assembled and attached. Receptacles, infeeds, and screen-to-screen jumpers are specified separately Hardwired (Chicago) power option includes 2"x3" conventional outlet boxes factory mounted with brackets to the underside of the screen. All other electrical fittings, wires, receptacles, and face plates are provided by electrician Optional data cutouts are sized 2.88 x 1.82" with two drill holes to accommodate a #6-32 screw. Requires a 45 degree angled wall plate (not supplied) May not be used as a freestanding screen on its own. Must be mechanically attached to another Spine Screen (with or without electrical) 	TSSPE4854	<input type="checkbox"/> <input type="checkbox"/> <input type="checkbox"/> <input type="checkbox"/>	<input type="checkbox"/> <input type="checkbox"/> <input type="checkbox"/> <input type="checkbox"/>	<input type="checkbox"/>	<input type="checkbox"/>	101.00#	\$ 2089
	TSSPE5454	<input type="checkbox"/> <input type="checkbox"/> <input type="checkbox"/> <input type="checkbox"/>	<input type="checkbox"/> <input type="checkbox"/> <input type="checkbox"/> <input type="checkbox"/>	<input type="checkbox"/>	<input type="checkbox"/>	110.00#	2272
	TSSPE6054	<input type="checkbox"/> <input type="checkbox"/> <input type="checkbox"/> <input type="checkbox"/>	<input type="checkbox"/> <input type="checkbox"/> <input type="checkbox"/> <input type="checkbox"/>	<input type="checkbox"/>	<input type="checkbox"/>	119.00#	2361
	TSSPE6654	<input type="checkbox"/> <input type="checkbox"/> <input type="checkbox"/> <input type="checkbox"/>	<input type="checkbox"/> <input type="checkbox"/> <input type="checkbox"/> <input type="checkbox"/>	<input type="checkbox"/>	<input type="checkbox"/>	128.00#	2559
	TSSPE7254	<input type="checkbox"/> <input type="checkbox"/> <input type="checkbox"/> <input type="checkbox"/>	<input type="checkbox"/> <input type="checkbox"/> <input type="checkbox"/> <input type="checkbox"/>	<input type="checkbox"/>	<input type="checkbox"/>	137.00#	2646
	TSSPE7854	<input type="checkbox"/> <input type="checkbox"/> <input type="checkbox"/> <input type="checkbox"/>	<input type="checkbox"/> <input type="checkbox"/> <input type="checkbox"/> <input type="checkbox"/>	<input type="checkbox"/>	<input type="checkbox"/>	146.00#	2794
	TSSPE8454	<input type="checkbox"/> <input type="checkbox"/> <input type="checkbox"/> <input type="checkbox"/>	<input type="checkbox"/> <input type="checkbox"/> <input type="checkbox"/> <input type="checkbox"/>	<input type="checkbox"/>	<input type="checkbox"/>	155.00#	2845
	TSSPE9054	<input type="checkbox"/> <input type="checkbox"/> <input type="checkbox"/> <input type="checkbox"/>	<input type="checkbox"/> <input type="checkbox"/> <input type="checkbox"/> <input type="checkbox"/>	<input type="checkbox"/>	<input type="checkbox"/>	164.00#	2991
	TSSPE9654	<input type="checkbox"/> <input type="checkbox"/> <input type="checkbox"/> <input type="checkbox"/>	<input type="checkbox"/> <input type="checkbox"/> <input type="checkbox"/> <input type="checkbox"/>	<input type="checkbox"/>	<input type="checkbox"/>	173.00#	3031

A **B** **C** **D** **E**

HOW TO ORDER

- Indicate the following information on order form:
- Quantity of each item.
 - Model number, including options. See "How to Build a Model Number".
 - Any special service required.

Note: • The indicates that a choice is required.
 • The absence of the indicates that no choice is required.
 • Alpha-numeric characters in place of indicate that no other alternatives are available.

HOW TO BUILD A MODEL NUMBER

- A** Select basic model.
- B** Select power option.
 - 1P** - 10-Wire power cutouts on 1 side only/no cutouts side 2
 - DP** - 10-Wire power cutouts only both sides
 - 2D** - 10-Wire power cutouts both sides/data cutouts on 1 side only
 - 1D** - 10-Wire power w/data cutouts on 1 side only/no cutouts side 2
 - DD** - 10-Wire power w/data cutouts both sides
 - CP** - Hardwired/Chicago power cutouts only both sides
 - CD** - Hardwired/Chicago power w/data cutouts both sides
- C** Select bezel color. Refer to the **Product Color Options** page in this price list.
- D** Select top cap style.
 - F** - Flat aluminum top cap (standard)
 - N** - No top cap (specify for use with toppers)
- E** Select frame color. Refer to the **Product Color Options** page in this price list.

SPECIAL SERVICES

Special Carton Marking

With specially marked information N/C

Shipping
 Ships assembled, FOB Manitowoc, WI 54220, freight prepaid. Freight class 70.

Specifications and prices are subject to change without prior notice.

Tattoo™ Spine Screens

Powered Monolithic Spine Screen with Thermally-Fused Laminate Core



Tattoo™ Spine Screens

Powered Monolithic Spine Screen with Thermally-Fused Laminate Core

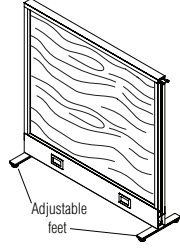
MODEL	MODEL NUMBER						Approx. Packaged Weight	Delivered Pricing	
	Basic Model	Power Option	Bezel Color	Top Cap Style	Frame Color	Laminate Color			
 <p>TSSPM</p> <p>Powered Monolithic Spine Screen with Thermally-Fused Laminate Core - 48" H</p> <ul style="list-style-type: none"> Spine screens support straight-line power planning only Spine screen assembly includes powder-coated aluminum frame, core material, adjustable foot base, raceway cover with two power cutouts/bezels, and one data cutout (when specified) Frame ships with top cap. Specify "no top cap" with accessory toppers. Vertical trim is specified separately Thermally-fused laminate is non-tackable and non-magnetic Standard base raceway on both sides accepts power and data cable distribution Ships assembled, except for feet which require on site attachment Slotting under upper trim accepts screen-hung accessories Standard power includes two 10-wire rigid wireways with in-line connecting jumper. Wireways are factory assembled and attached. Receptacles, infeeds, and screen-to-screen jumpers are specified separately Hardwired (Chicago) power option includes 2"x3" conventional outlet boxes factory mounted with brackets to the underside of the screen. All other electrical fittings, wires, receptacles, and face plates are provided by electrician. Optional data cutouts are sized 2.88 x 1.82" with two drill holes to accommodate a #6-32 screw. Requires a 45 degree angled wall plate (not supplied) May not be used as a freestanding screen on its own. Must be mechanically attached to another Spine Screen (with or without electrical) 	TSSPM4848	<input type="checkbox"/>	<input type="checkbox"/>	<input type="checkbox"/>	<input type="checkbox"/>	<input type="checkbox"/>	93.00#	\$ 1562	
	TSSPM5448	<input type="checkbox"/>	<input type="checkbox"/>	<input type="checkbox"/>	<input type="checkbox"/>	<input type="checkbox"/>	<input type="checkbox"/>	101.00#	1719
	TSSPM6048	<input type="checkbox"/>	<input type="checkbox"/>	<input type="checkbox"/>	<input type="checkbox"/>	<input type="checkbox"/>	<input type="checkbox"/>	109.00#	1796
	TSSPM6648	<input type="checkbox"/>	<input type="checkbox"/>	<input type="checkbox"/>	<input type="checkbox"/>	<input type="checkbox"/>	<input type="checkbox"/>	117.00#	1875
	TSSPM7248	<input type="checkbox"/>	<input type="checkbox"/>	<input type="checkbox"/>	<input type="checkbox"/>	<input type="checkbox"/>	<input type="checkbox"/>	125.00#	1953
	TSSPM7848	<input type="checkbox"/>	<input type="checkbox"/>	<input type="checkbox"/>	<input type="checkbox"/>	<input type="checkbox"/>	<input type="checkbox"/>	133.00#	1988
	TSSPM8448	<input type="checkbox"/>	<input type="checkbox"/>	<input type="checkbox"/>	<input type="checkbox"/>	<input type="checkbox"/>	<input type="checkbox"/>	141.00#	2024
	TSSPM9048	<input type="checkbox"/>	<input type="checkbox"/>	<input type="checkbox"/>	<input type="checkbox"/>	<input type="checkbox"/>	<input type="checkbox"/>	149.00#	2060
	TSSPM9648	<input type="checkbox"/>	<input type="checkbox"/>	<input type="checkbox"/>	<input type="checkbox"/>	<input type="checkbox"/>	<input type="checkbox"/>	157.00#	2094

A **B** **C** **D** **E** **F**

HOW TO ORDER

- Indicate the following information on order form:
- Quantity of each item.
 - Model number, including options. See "How To Build a Model Number".
 - Any special service required.

Note:

- The indicates that a choice is required.
- The absence of the indicates that no choice is required.
- Alpha-numeric characters in place of indicate that no other alternatives are available.

HOW TO BUILD A MODEL NUMBER

- A** Select basic model.
- B** Select power option.
 - 1P** - 10-Wire power cutouts on 1 side only/no cutouts side 2
 - DP** - 10-Wire power cutouts only both sides
 - 2D** - 10-Wire power cutouts both sides/data cutouts on 1 side only
 - 1D** - 10-Wire power w/data cutouts on 1 side only/no cutouts side 2
 - DD** - 10-Wire power w/data cutouts both sides
 - CP** - Hardwired/Chicago power cutouts only both sides
 - CD** - Hardwired/Chicago power w/data cutouts both sides
- C** Select bezel color. Refer to the **Product Color Options** page in this price list.
- D** Select top cap style.
 - F** - Flat aluminum top cap (standard)
 - N** - No top cap (specify for use with toppers)
- E** Select frame color. Refer to the **Product Color Options** page in this price list.
- F** Select laminate. Refer to the **Product Color Options** page in this price list.

SPECIAL SERVICES

Special Carton Marking
 With specially marked information N/C

Shipping
 Ships assembled, FOB Manitowoc, WI 54220, freight prepaid. Freight class 70.

Specifications and prices are subject to change without prior notice.

Tattoo™ Spine Screens

Powered Monolithic Spine Screen with Thermally-Fused Laminate Core



Tattoo™ Spine Screens

Powered Monolithic Spine Screen with Thermally-Fused Laminate Core

MODEL	MODEL NUMBER						Approx. Packaged Weight	Delivered Pricing
	Basic Model	Power Option	Bezel Color	Top Cap Style	Frame Color	Laminate Color		
TSSPM Powered Monolithic Spine Screen with Thermally-Fused Laminate Core - 54”H <ul style="list-style-type: none"> Spine screens support straight-line power planning only Spine screen assembly includes powder-coated aluminum frame, core material, adjustable foot base, raceway cover with two power cutouts/bezels, and one data cutout (when specified) Frame ships with top cap. Specify “no top cap” with accessory toppers. Vertical trim is specified separately Thermally-fused laminate is non-tackable and non-magnetic Standard base raceway on both sides accepts power and data cable distribution Ships assembled, except for feet which require on site attachment Slotting under upper trim accepts screen-hung accessories Standard power includes two 10-wire rigid wireways with in-line connecting jumper. Wireways are factory assembled and attached. Receptacles, infeeds, and screen-to-screen jumpers are specified separately Hardwired (Chicago) power option includes 2”x3” conventional outlet boxes factory mounted with brackets to the underside of the screen. All other electrical fittings, wires, receptacles, and face plates are provided by electrician Optional data cutouts are sized 2.88 x 1.82” with two drill holes to accommodate a #6-32 screw. Requires a 45 degree angled wall plate (not supplied) May not be used as a freestanding screen on its own. Must be mechanically attached to another Spine Screen (with or without electrical) 	TSSPM4854	<input type="checkbox"/> <input type="checkbox"/> <input type="checkbox"/> <input type="checkbox"/>	<input type="checkbox"/> <input type="checkbox"/>	<input type="checkbox"/>	<input type="checkbox"/>	<input type="checkbox"/> <input type="checkbox"/>	101.00#	\$ 1572
	TSSPM5454	<input type="checkbox"/> <input type="checkbox"/> <input type="checkbox"/> <input type="checkbox"/>	<input type="checkbox"/> <input type="checkbox"/>	<input type="checkbox"/>	<input type="checkbox"/>	<input type="checkbox"/> <input type="checkbox"/>	110.00#	1731
	TSSPM6054	<input type="checkbox"/> <input type="checkbox"/> <input type="checkbox"/> <input type="checkbox"/>	<input type="checkbox"/> <input type="checkbox"/>	<input type="checkbox"/>	<input type="checkbox"/>	<input type="checkbox"/> <input type="checkbox"/>	119.00#	1808
	TSSPM6654	<input type="checkbox"/> <input type="checkbox"/> <input type="checkbox"/> <input type="checkbox"/>	<input type="checkbox"/> <input type="checkbox"/>	<input type="checkbox"/>	<input type="checkbox"/>	<input type="checkbox"/> <input type="checkbox"/>	128.00#	1888
	TSSPM7254	<input type="checkbox"/> <input type="checkbox"/> <input type="checkbox"/> <input type="checkbox"/>	<input type="checkbox"/> <input type="checkbox"/>	<input type="checkbox"/>	<input type="checkbox"/>	<input type="checkbox"/> <input type="checkbox"/>	137.00#	1964
	TSSPM7854	<input type="checkbox"/> <input type="checkbox"/> <input type="checkbox"/> <input type="checkbox"/>	<input type="checkbox"/> <input type="checkbox"/>	<input type="checkbox"/>	<input type="checkbox"/>	<input type="checkbox"/> <input type="checkbox"/>	146.00#	2000
	TSSPM8454	<input type="checkbox"/> <input type="checkbox"/> <input type="checkbox"/> <input type="checkbox"/>	<input type="checkbox"/> <input type="checkbox"/>	<input type="checkbox"/>	<input type="checkbox"/>	<input type="checkbox"/> <input type="checkbox"/>	155.00#	2034
	TSSPM9054	<input type="checkbox"/> <input type="checkbox"/> <input type="checkbox"/> <input type="checkbox"/>	<input type="checkbox"/> <input type="checkbox"/>	<input type="checkbox"/>	<input type="checkbox"/>	<input type="checkbox"/> <input type="checkbox"/>	164.00#	2072
	TSSPM9654	<input type="checkbox"/> <input type="checkbox"/> <input type="checkbox"/> <input type="checkbox"/>	<input type="checkbox"/> <input type="checkbox"/>	<input type="checkbox"/>	<input type="checkbox"/>	<input type="checkbox"/> <input type="checkbox"/>	173.00#	2106

A **B** **C** **D** **E** **F**

HOW TO ORDER

- Indicate the following information on order form:
- Quantity of each item.
 - Model number, including options. See “How To Build a Model Number”.
 - Any special service required.

Note: • The indicates that a choice is required.
 • The absence of the indicates that no choice is required.
 • Alpha-numeric characters in place of indicate that no other alternatives are available.

HOW TO BUILD A MODEL NUMBER

- A** Select basic model.
- B** Select power option.
 - 1P** - 10-Wire power cutouts on 1 side only/no cutouts side 2
 - DP** - 10-Wire power cutouts only both sides
 - 2D** - 10-Wire power cutouts both sides/data cutouts on 1 side only
 - 1D** - 10-Wire power w/data cutouts on 1 side only/no cutouts side 2
 - DD** - 10-Wire power w/data cutouts both sides
 - CP** - Hardwired/Chicago power cutouts only both sides
 - CD** - Hardwired/Chicago power w/data cutouts both sides
- C** Select bezel color. Refer to the **Product Color Options** page in this price list.
- D** Select top cap style.
 - F** - Flat aluminum top cap (standard)
 - N** - No top cap (specify for use with toppers)
- E** Select frame color. Refer to the **Product Color Options** page in this price list.
- F** Select laminate. Refer to the **Product Color Options** page in this price list.

SPECIAL SERVICES

Special Carton Marking

With specially marked information N/C

Shipping

Ships **assembled, FOB Manitowoc, WI 54220, freight prepaid.** Freight class 70.

Specifications and prices are subject to change without prior notice.

Tattoo™ Spine Screens

Non-Powered Monolithic Spine Screen with Magnetic Dry-Erasable Steel Core



Tattoo™ Spine Screens

Non-Powered Monolithic Spine Screen with Magnetic Dry-Erasable Steel Core

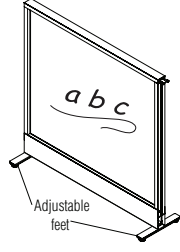
MODEL	MODEL NUMBER				Approx. Packaged Weight	Delivered Pricing
	Basic Model	Data Cutout	Top Cap Style	Frame Color		
 <p>TSSNE</p> <p>Non-Powered Monolithic Spine Screen with Magnetic Dry-Erasable Steel Core - 48" H</p> <ul style="list-style-type: none"> Spine Screens are for straight run applications only Non-powered spine screen assembly includes powder-coated aluminum frame, core material, base cover with one optional data cutout per side, and adjustable feet Frame ships with top cap when specified. Specify "no top cap" with accessory toppers. Vertical trim is specified separately Steel core is dry-erasable and magnetic Ships assembled, except for feet which require on site attachment Slotting under upper trim accepts screen-hung accessories Optional data cutouts are sized 2.88 x 1.82" with two drill holes to accommodate a #6-32 screw. Requires a 45 degree angled wall plate (not supplied) May not be used as a freestanding screen on its own. Must be mechanically attached to another Spine Screen (with or without electrical) 	TSSNE4848	<input type="checkbox"/>	<input type="checkbox"/>	<input type="checkbox"/>	90.00#	\$ 1649
	TSSNE5448	<input type="checkbox"/>	<input type="checkbox"/>	<input type="checkbox"/>	98.00#	1813
	TSSNE6048	<input type="checkbox"/>	<input type="checkbox"/>	<input type="checkbox"/>	106.00#	1866
	TSSNE6648	<input type="checkbox"/>	<input type="checkbox"/>	<input type="checkbox"/>	114.00#	2029
	TSSNE7248	<input type="checkbox"/>	<input type="checkbox"/>	<input type="checkbox"/>	122.00#	2083
	TSSNE7848	<input type="checkbox"/>	<input type="checkbox"/>	<input type="checkbox"/>	130.00#	2246
	TSSNE8448	<input type="checkbox"/>	<input type="checkbox"/>	<input type="checkbox"/>	138.00#	2300
	TSSNE9048	<input type="checkbox"/>	<input type="checkbox"/>	<input type="checkbox"/>	146.00#	2462
	TSSNE9648	<input type="checkbox"/>	<input type="checkbox"/>	<input type="checkbox"/>	154.00#	2516

A **B** **C** **D**

HOW TO ORDER

- Indicate the following information on order form:
- Quantity of each item.
 - Model number, including options. See "How To Build a Model Number".
 - Any special service required.

Note:

- The indicates that a choice is required.
- The absence of the indicates that no choice is required.
- Alpha-numeric characters in place of indicate that no other alternatives are available.

HOW TO BUILD A MODEL NUMBER

- A** Select basic model.
- B** Select data cutout.

NC	- No cutout either side
DN	- Data cutout 1 side
DC	- Data cutout 2 sides
- C** Select top cap style.

F	- Flat aluminum top cap (standard)
N	- No top cap (specify for use with toppers)
- D** Select frame color. Refer to the **Product Color Options** page in this price list.

SPECIAL SERVICES

Special Carton Marking
 With specially marked information N/C

Shipping
 Ships assembled, FOB Manitowoc, WI 54220, freight prepaid. Freight class 70.

Specifications and prices are subject to change without prior notice.

Tattoo™ Spine Screens

Non-Powered Monolithic Spine Screen with Magnetic Dry-Erasable Steel Core



Tattoo™ Spine Screens

Non-Powered Monolithic Spine Screen with Magnetic Dry-Erasable Steel Core

MODEL	MODEL NUMBER				Approx. Packaged Weight	Delivered Pricing
	Basic Model	Data Cutout	Top Cap Style	Frame Color		
TSSNE Non-Powered Monolithic Spine Screen with Magnetic Dry-Erasable Steel Core - 54" H <ul style="list-style-type: none"> Spine Screens are for straight run applications only Non-powered spine screen assembly includes powder-coated aluminum frame, core material, base cover with one optional data cutout per side, and adjustable feet Frame ships with top cap when specified. Specify "no top cap" with accessory toppers. Vertical trim is specified separately Steel core is dry-erasable and magnetic Ships assembled, except for feet which require on site attachment Slotting under upper trim accepts screen-hung accessories Optional data cutouts are sized 2.88 x 1.82" with two drill holes to accommodate a #6-32 screw. Requires a 45 degree angled wall plate (not supplied) May not be used as a freestanding screen on its own. Must be mechanically attached to another Spine Screen (with or without electrical) 	TSSNE4854	<input type="checkbox"/>	<input type="checkbox"/>	<input type="checkbox"/>	98.00#	\$ 1662
	TSSNE5454	<input type="checkbox"/>	<input type="checkbox"/>	<input type="checkbox"/>	107.00#	1810
	TSSNE6054	<input type="checkbox"/>	<input type="checkbox"/>	<input type="checkbox"/>	116.00#	1864
	TSSNE6654	<input type="checkbox"/>	<input type="checkbox"/>	<input type="checkbox"/>	125.00#	2025
	TSSNE7254	<input type="checkbox"/>	<input type="checkbox"/>	<input type="checkbox"/>	134.00#	2079
	TSSNE7854	<input type="checkbox"/>	<input type="checkbox"/>	<input type="checkbox"/>	143.00#	2243
	TSSNE8454	<input type="checkbox"/>	<input type="checkbox"/>	<input type="checkbox"/>	152.00#	2307
	TSSNE9054	<input type="checkbox"/>	<input type="checkbox"/>	<input type="checkbox"/>	161.00#	2466
	TSSNE9654	<input type="checkbox"/>	<input type="checkbox"/>	<input type="checkbox"/>	170.00#	2521

A **B** **C** **D**

HOW TO ORDER

- Indicate the following information on order form:
- Quantity of each item.
 - Model number, including options. See "How To Build a Model Number".
 - Any special service required.

Note:

- The indicates that a choice is required.
- The absence of the indicates that no choice is required.
- Alpha-numeric characters in place of indicate that no other alternatives are available.

HOW TO BUILD A MODEL NUMBER

- A** Select basic model.
- B** Select data cutout.

NC	- No cutout either side
DN	- Data cutout 1 side
DC	- Data cutout 2 sides
- C** Select top cap style.

F	- Flat aluminum top cap (standard)
N	- No top cap (specify for use with toppers)
- D** Select frame color. Refer to the **Product Color Options** page in this price list.

SPECIAL SERVICES

Special Carton Marking

With specially marked information N/C

Shipping

Ships **assembled, FOB Manitowoc, WI 54220, freight prepaid.** Freight class 70.

Specifications and prices are subject to change without prior notice.

Tattoo™ Spine Screens

Non-Powered Monolithic Spine Screen with Thermally-Fused Laminate Core



Tattoo™ Spine Screens

Non-Powered Monolithic Spine Screen with Thermally-Fused Laminate Core

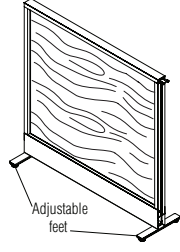
MODEL	MODEL NUMBER					Approx. Packaged Weight	Delivered Pricing
	Basic Model	Data Cutout	Top Cap Style	Frame Color	Laminate Color		
 <p>TSSNM</p> <p>Non-Powered Monolithic Spine Screen with Thermally-Fused Laminate Core - 48" H</p> <ul style="list-style-type: none"> Spine Screens are for straight run applications only Non-powered spine screen assembly includes powder-coated aluminum frame, core material, base cover with one optional data cutout per side, and adjustable feet Frame ships with top cap when specified. Specify "no top cap" with accessory toppers. Vertical trim is specified separately Core is non-tackable and non-magnetic Ships assembled, except for feet which require on site attachment Slotting under upper trim accepts screen-hung accessories Optional data cutouts are sized 2.88 x 1.82" with two drill holes to accommodate a #6-32 screw. Requires a 45 degree angled wall plate (not supplied) May not be used as a freestanding screen on its own. Must be mechanically attached to another Spine Screen (with or without electrical) 	TSSNM4848	<input type="checkbox"/>	<input type="checkbox"/>	<input type="checkbox"/>	<input type="checkbox"/>	90.00#	\$ 1186
	TSSNM5448	<input type="checkbox"/>	<input type="checkbox"/>	<input type="checkbox"/>	<input type="checkbox"/>	98.00#	1314
	TSSNM6048	<input type="checkbox"/>	<input type="checkbox"/>	<input type="checkbox"/>	<input type="checkbox"/>	106.00#	1361
	TSSNM6648	<input type="checkbox"/>	<input type="checkbox"/>	<input type="checkbox"/>	<input type="checkbox"/>	114.00#	1407
	TSSNM7248	<input type="checkbox"/>	<input type="checkbox"/>	<input type="checkbox"/>	<input type="checkbox"/>	122.00#	1455
	TSSNM7848	<input type="checkbox"/>	<input type="checkbox"/>	<input type="checkbox"/>	<input type="checkbox"/>	130.00#	1503
	TSSNM8448	<input type="checkbox"/>	<input type="checkbox"/>	<input type="checkbox"/>	<input type="checkbox"/>	138.00#	1549
	TSSNM9048	<input type="checkbox"/>	<input type="checkbox"/>	<input type="checkbox"/>	<input type="checkbox"/>	146.00#	1598
	TSSNM9648	<input type="checkbox"/>	<input type="checkbox"/>	<input type="checkbox"/>	<input type="checkbox"/>	154.00#	1647

A **B** **C** **D** **E**

HOW TO ORDER

- Indicate the following information on order form:
- Quantity of each item.
 - Model number, including options. See "How To Build a Model Number".
 - Any special service required.

Note:

- The indicates that a choice is required.
- The absence of the indicates that no choice is required.
- Alpha-numeric characters in place of indicate that no other alternatives are available.

HOW TO BUILD A MODEL NUMBER

- A** Select basic model.
- B** Select data cutout.

NC	- No cutout either side
DN	- Data cutout 1 side
DC	- Data cutout 2 sides
- C** Select top cap style.

F	- Flat aluminum top cap (standard)
N	- No top cap (specify for use with toppers)
- D** Select frame color. Refer to the **Product Color Options** page in this price list.
- E** Select laminate. Refer to the **Product Color Options** page in this price list.

SPECIAL SERVICES

Special Carton Marking
 With specially marked information N/C

Shipping
 Ships assembled, FOB Manitowoc, WI 54220, freight prepaid. Freight class 70.

Specifications and prices are subject to change without prior notice.

Tattoo™ Spine Screens

Non-Powered Monolithic Spine Screen with Thermally-Fused Laminate Core



Tattoo™ Spine Screens

Non-Powered Monolithic Spine Screen with Thermally-Fused Laminate Core

MODEL	MODEL NUMBER					Approx. Packaged Weight	Delivered Pricing
	Basic Model	Data Cutout	Top Cap Style	Frame Color	Laminate Color		
TSSNM Non-Powered Monolithic Spine Screen with Thermally-Fused Laminate Core - 54" H <ul style="list-style-type: none"> Spine Screens are for straight run applications only Non-powered spine screen assembly includes powder-coated aluminum frame, core material, base cover with one optional data cutout per side, and adjustable feet Frame ships with top cap when specified. Specify "no top cap" with accessory toppers. Vertical trim is specified separately Core is non-tackable and non-magnetic Ships assembled, except for feet which require on site attachment Slotting under upper trim accepts screen-hung accessories Optional data cutouts are sized 2.88 x 1.82" with two drill holes to accommodate a #6-32 screw. Requires a 45 degree angled wall plate (not supplied) May not be used as a freestanding screen on its own. Must be mechanically attached to another Spine Screen (with or without electrical) 	TSSNM4854	<input type="checkbox"/>	<input type="checkbox"/>	<input type="checkbox"/>	<input type="checkbox"/>	98.00#	\$ 1196
	TSSNM5454	<input type="checkbox"/>	<input type="checkbox"/>	<input type="checkbox"/>	<input type="checkbox"/>	107.00#	1325
	TSSNM6054	<input type="checkbox"/>	<input type="checkbox"/>	<input type="checkbox"/>	<input type="checkbox"/>	116.00#	1373
	TSSNM6654	<input type="checkbox"/>	<input type="checkbox"/>	<input type="checkbox"/>	<input type="checkbox"/>	125.00#	1419
	TSSNM7254	<input type="checkbox"/>	<input type="checkbox"/>	<input type="checkbox"/>	<input type="checkbox"/>	134.00#	1466
	TSSNM7854	<input type="checkbox"/>	<input type="checkbox"/>	<input type="checkbox"/>	<input type="checkbox"/>	143.00#	1515
	TSSNM8454	<input type="checkbox"/>	<input type="checkbox"/>	<input type="checkbox"/>	<input type="checkbox"/>	152.00#	1562
	TSSNM9054	<input type="checkbox"/>	<input type="checkbox"/>	<input type="checkbox"/>	<input type="checkbox"/>	161.00#	1612
	TSSNM9654	<input type="checkbox"/>	<input type="checkbox"/>	<input type="checkbox"/>	<input type="checkbox"/>	170.00#	1658

A **B** **C** **D** **E**

HOW TO ORDER

- Indicate the following information on order form:
- Quantity of each item.
 - Model number, including options. See "How To Build a Model Number".
 - Any special service required.

Note:

- The indicates that a choice is required.
- The absence of the indicates that no choice is required.
- Alpha-numeric characters in place of indicate that no other alternatives are available.

HOW TO BUILD A MODEL NUMBER

- A** Select basic model.
- B** Select data cutout.

NC	- No cutout either side
DN	- Data cutout 1 side
DC	- Data cutout 2 sides
- C** Select top cap style.

F	- Flat aluminum top cap (standard)
N	- No top cap (specify for use with toppers)
- D** Select frame color. Refer to the **Product Color Options** page in this price list.
- E** Select laminate. Refer to the **Product Color Options** page in this price list.

SPECIAL SERVICES

Special Carton Marking

With specially marked information N/C

Shipping

Ships **assembled, FOB Manitowoc, WI 54220, freight prepaid.** Freight class 70.

Specifications and prices are subject to change without prior notice.

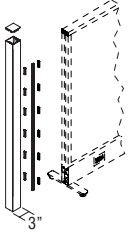

MODEL	H	MODEL NUMBER		Approx. Packaged Weight	Delivered Pricing
		Basic Model	Frame/Trim Color		
 <p>End-of-Run Trim Kit</p> <ul style="list-style-type: none"> Specify for end-of-run conditions for Tattoo Spine Screens only Select by screen height Includes end cap and hardware 	48"	TEOR48	<input type="checkbox"/>	5.0#	\$ 90
	54"	TEOR54	<input type="checkbox"/>	5.0#	102
 <p>End-of-Run Spacer Trim Kit</p> <ul style="list-style-type: none"> Specify for end-of-run Tattoo Spine Screens conditions that do not require an infeed Select by screen height Includes end cap and hardware Non-powered; does not provide power access cutout 3" wide 	48"	TSEOR48	<input type="checkbox"/>	10.0#	\$ 497
	54"	TSEOR54	<input type="checkbox"/>	10.0#	498

A

B

HOW TO ORDER

- Indicate the following information on order form:
- Quantity of each item.
 - Model number, including options. See "How To Build a Model Number".
 - Any special service required.

- Note:
- The indicates that a choice is required.
 - The absence of the indicates that no choice is required.
 - Alpha-numeric characters in place of indicate that no other alternatives are available.

HOW TO BUILD A MODEL NUMBER

- A** Select basic model.
- B** Select frame/trim color. Refer to the **Product Color Options** page in this price list.

SPECIAL SERVICES

Special Carton Marking

With specially marked information N/C

Shipping

Ships **knocked down, FOB Manitowoc, WI 54220, freight prepaid.** Freight class 70.

Specifications and prices are subject to change without prior notice.

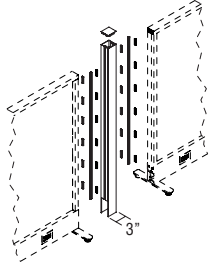
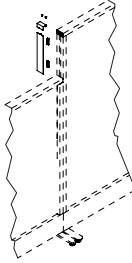

MODEL	H	MODEL NUMBER		Approx. Packaged Weight	Delivered Pricing
		Basic Model	Frame/Trim Color		
 <p>In-Line Spacer Trim Kit</p> <ul style="list-style-type: none"> Specify for in-line spine screen conditions Non-powered, allows for power or data cable pass through Specify by screen height Includes trim and hardware 3" wide 	48"	TSIS48	<input type="checkbox"/>	10.0#	\$ 440
	54"	TSIS54	<input type="checkbox"/>	10.0#	441
TSTK					
 <p>Change of Height Trim Kit</p> <ul style="list-style-type: none"> Specify for in-line change of height conditions for Spine Screens Includes end cap and hardware Toppers may not be used on 48" high screens in change of height conditions 	6"	TEORV6	<input type="checkbox"/>	2.0#	\$ 104
TSTK					
		A	B		

HOW TO ORDER

- Indicate the following information on order form:
- Quantity of each item.
 - Model number, including options. See "How To Build a Model Number".
 - Any special service required.

Note:

- The indicates that a choice is required.
- The absence of the indicates that no choice is required.
- Alpha-numeric characters in place of indicate that no other alternatives are available.

HOW TO BUILD A MODEL NUMBER

- A** Select basic model.
- B** Select frame/trim color. Refer to the **Product Color Options** page in this price list.

SPECIAL SERVICES

Special Carton Marking

With specially marked information N/C

Shipping

Ships **knocked down, FOB Manitowoc, WI 54220, freight prepaid.** Freight class 70.

Specifications and prices are subject to change without prior notice.

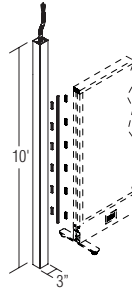
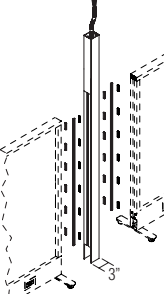

MODEL	H	MODEL NUMBER			Approx. Packaged Weight	Delivered Pricing
		Basic Model	Power Option	Frame/Trim Color		
 <p>Top Infeed Trim Kit - End-of-Run</p> <ul style="list-style-type: none"> Kit includes a 12' power infeed (when power is specified) 10' power pole and hardware 15' kit includes an 18' power infeed, a 10' pole with 5' extension which may be field-cut to size, a splice plate and hardware Specify for end-of-run top in-feed conditions only 	10'	TTF10	<input type="checkbox"/>	<input type="checkbox"/>	30.0#	\$ 572
	15'	TTF15	<input type="checkbox"/>	<input type="checkbox"/>	40.0#	837
 <p>Top Infeed Trim Kit - In-Line</p> <ul style="list-style-type: none"> Kit includes a 12' power infeed (when power is specified) 10' power pole and hardware 15' kit includes an 18' power infeed, a 10' pole with 5' extension which may be field-cut to size, a splice plate and hardware Specify for in-line top feed conditions only 	10'	TITF10	<input type="checkbox"/>	<input type="checkbox"/>	30.0#	\$ 587
	15'	TITF15	<input type="checkbox"/>	<input type="checkbox"/>	40.0#	850

A **B** **C**

HOW TO ORDER

- Indicate the following information on order form:
- Quantity of each item.
 - Model number, including options. See "How To Build a Model Number".
 - Any special service required.

Note:

- The indicates that a choice is required.
- The absence of the indicates that no choice is required.
- Alpha-numeric characters in place of indicate that no other alternatives are available.

HOW TO BUILD A MODEL NUMBER

- A** Select basic model.
- B** Select power option.
 - N** - No power; for hardwire (Chicago) installations
 - 6** - 10 wire, 6 circuit power infeed; add \$217
 - NY** - New York infeed; add \$759
 - NY - New York Infeed NOT available on TITF
- C** Select frame/trim color. Refer to the **Product Color Options** page in this price list.

SPECIAL SERVICES

Special Carton Marking
With specially marked information N/C

Shipping
Ships **knocked down, FOB Manitowoc, WI 54220, freight prepaid.** Freight class 70.

Specifications and prices are subject to change without prior notice.

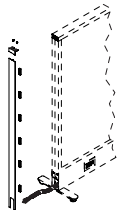
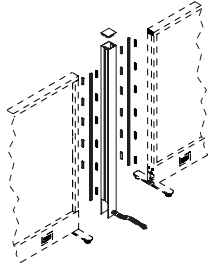
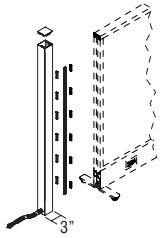

MODEL	H	MODEL NUMBER				Approx. Packaged Weight	Delivered Pricing
		Basic Model	Power Option	Frame/Trim Color	Infeed Color		
 <p>Base Infeed Kit - End-of-Run</p> <ul style="list-style-type: none"> Kit includes power infeed with 8' conduit (when power is specified) and hardware Specify for end-of-run base infeed conditions only 	48"	TBF48	<input type="checkbox"/>	<input type="checkbox"/>	<input type="checkbox"/>	8.0#	\$ 78
	54"	TBF54	<input type="checkbox"/>	<input type="checkbox"/>	<input type="checkbox"/>	8.0#	91
TSIK							
 <p>Base Infeed Kit - In-Line</p> <ul style="list-style-type: none"> Kit includes power infeed with 8' conduit and hardware (when power is specified) Specify for in-line base infeed conditions to create 3" of space between two Spine Screens 	48"	TIBF48	<input type="checkbox"/>	<input type="checkbox"/>	<input type="checkbox"/>	20.0#	\$ 396
	54"	TIBF54	<input type="checkbox"/>	<input type="checkbox"/>	<input type="checkbox"/>	20.0#	400
TSIK							
 <p>Base Infeed Kit - End-of-Run Spacer</p> <ul style="list-style-type: none"> Kit includes power infeed with 8' conduit (when power is specified) and hardware Specify for infeed conditions to add 3" of trim to end-of-run 	48"	TSBF48	<input type="checkbox"/>	<input type="checkbox"/>	<input type="checkbox"/>	20.0#	\$ 455
	54"	TSBF54	<input type="checkbox"/>	<input type="checkbox"/>	<input type="checkbox"/>	20.0#	462
TSIK							
			A	B	C	D	

HOW TO ORDER

- Indicate the following information on order form:
- Quantity of each item.
 - Model number, including options. See "How To Build a Model Number".
 - Any special service required.

Note:

- The indicates that a choice is required.
- The absence of the indicates that no choice is required.
- Alpha-numeric characters in place of indicate that no other alternatives are available.

HOW TO BUILD A MODEL NUMBER

- A** Select basic model.
- B** Select power option.
 - N** - No power; for hardwire (Chicago) installations
 - 6** - 10 wire, 6 circuit power infeed; add \$130
 - NY** - New York infeed; add \$759
 - NY - New York Infeed NOT available on TIBF
- C** Select frame/trim color. Refer to the **Product Color Options** page in this price list.
- D** Select infeed color. Refer to the **Product Color Options** page in this price list.

SPECIAL SERVICES

Special Carton Marking

With specially marked information N/C

Shipping

Ships **knocked down, FOB Manitowoc, WI 54220, freight prepaid.** Freight class 70.

Specifications and prices are subject to change without prior notice.

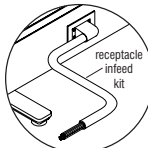

MODEL	MODEL NUMBER		Approx. Packaged Weight	Delivered Pricing
	Basic Model	Infeed Color		
 <p>Receptacle Infeed</p> <ul style="list-style-type: none"> • Kit includes power infeed with 6' conduit and hardware • Infeed occupies the space of one receptacle cutout 	TISRF	<input type="checkbox"/>	7.00#	\$ 159

TTA01

A

B

HOW TO ORDER

- Indicate the following information on order form:
1. Quantity of each item.
 2. Model number, including options. See "How To Build a Model Number".
 3. Any special service required.

- Note:
- The indicates that a choice is required.
 - The absence of the indicates that no choice is required.
 - Alpha-numeric characters in place of indicate that no other alternatives are available.

HOW TO BUILD A MODEL NUMBER

- A** Select basic model.
- B** Select infeed color. Refer to the **Product Color Options** page in this price list.

SPECIAL SERVICES

Special Carton Marking



With specially marked information N/C

Shipping

Ships **knocked down, FOB Manitowoc, WI 54220, freight prepaid.** Freight class 70.

Specifications and prices are subject to change without prior notice.

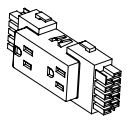
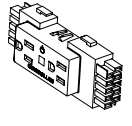

MODEL	Features	L	MODEL NUMBER		Approx. Packaged Weight	Delivered Pricing
			Basic Model	Color		
 TTA02	In-line Jumper - 6 Circuit • Specify TSIF.17 to pass power from one in-line Spine Screen to another • Specify TSIF.20 to pass power from one Spine Screen to another with an in-line spacer or in-line top feed condition • Non-directional	17-3/4"	TSIJ.17		2.00#	\$ 106
		21-1/4"	TSIJ.20		2.30#	129
 TTA02	Pass-Through Jumper - 6 Circuit • Specify to pass power through a non-powered Spine to a powered Spine Screen • Specify by non-powered screen width • Non-directional	48" Screen Width 65.5"	TSPT.48		2.30#	\$ 111
		54" Screen Width 71.5"	TSPT.54		2.30#	118
		60" Screen Width 77.5"	TSPT.60		2.30#	126
		66" Screen Width 83.5"	TSPT.66		2.30#	130
		72" Screen Width 89.5"	TSPT.72		2.30#	138
		78" Screen Width 95.5"	TSPT.78		2.30#	142
		84" Screen Width 101.5"	TSPT.84		2.30#	150
		90" Screen Width 107.5"	TSPT.90		2.30#	157
96" Screen Width 113.5"	TSPT.96		2.30#	162		
 TTA03	15 Amp Duplex Receptacle - 6 Circuit • Plugs into rigid wireway inside base of Spine Screen • Isolated receptacles are stamped with orange circuit number and isolated triangle designator	Circuit 1	TSRC.1	<input type="checkbox"/>	1.00#	\$ 15
		Circuit 2	TSRC.2	<input type="checkbox"/>	1.00#	15
		Circuit 3	TSRC.3	<input type="checkbox"/>	1.00#	15
		Circuit 4	TSRC.4I	<input type="checkbox"/>	1.00#	15
		Circuit 5	TSRC.5I	<input type="checkbox"/>	1.00#	15
		Circuit 6	TSRC.6I	<input type="checkbox"/>	1.00#	15
 TTA05	15 Amp Duplex Receptacle - 6 Circuit - Controlled • Marked receptacles are to be used with a customer supplied sensor or timer at the infeed to conserve energy • Not for use for continuous power draw applications • Plugs into rigid wireway inside base of Spine Screen	Circuit 1	TSRC.1C	<input type="checkbox"/>	1.00#	\$ 15
		Circuit 2	TSRC.2C	<input type="checkbox"/>	1.00#	15
		Circuit 3	TSRC.3C	<input type="checkbox"/>	1.00#	15

A

B

HOW TO ORDER

Indicate the following information on order form:

- Quantity of each item.
- Model number, including options. See "How To Build a Model Number".
- Any special service required.

Note: • The indicates that a choice is required.

- The absence of the indicates that no choice is required.
- Alpha-numeric characters in place of indicate that no other alternatives are available.

HOW TO BUILD A MODEL NUMBER

- A** Select basic model.
- B** Select color.
Refer to the **Product Color Options** page in this price list.

SPECIAL SERVICES

Special Carton Marking



With specially marked information N/C

Shipping

Ships **knocked down, FOB Manitowoc, WI 54220, freight prepaid**. Freight class 70.

Specifications and prices are subject to change without prior notice.

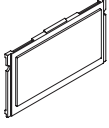

	MODEL	L	MODEL NUMBER		Approx. Packaged Weight	Delivered Pricing
			Basic Model	Color		
 <p>Filler Plate</p> <ul style="list-style-type: none"> Used to fill in bezel void if needed For replacement purposes only; powered Spine Screens come with four filler plates 			TSFP	<input type="checkbox"/>	1.00#	\$ 3
TTA03						
 <p>Data Cover Plate</p> <ul style="list-style-type: none"> Used to fill in data cutout if needed Includes attachment hardware 			49.0582	<input type="checkbox"/>	1.00#	\$ 20
TTA01						

A

B

HOW TO ORDER

Indicate the following information on order form:

- Quantity of each item.
- Model number, including options. See "How To Build a Model Number".
- Any special service required.

Note: • The indicates that a choice is required.

- The absence of the indicates that no choice is required.
- Alpha-numeric characters in place of indicate that no other alternatives are available.

HOW TO BUILD A MODEL NUMBER

- A** Select basic model.
- B** Select color. Refer to the **Product Color Options** page in this price list.

SPECIAL SERVICES

Special Carton Marking

With specially marked information N/C

Shipping

Ships **knocked down, FOB Manitowoc, WI 54220, freight prepaid**. Freight class 70.

Specifications and prices are subject to change without prior notice.

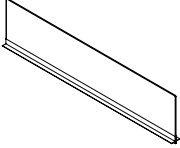
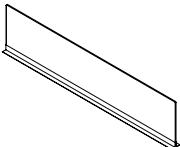

MODEL	W x H	MODEL NUMBER				Approx. Packaged Weight	Delivered Pricing
		Basic Model	Acrylic Color	Polyester Felt Color	Frame/Trim Color		
 <p>Acrylic Topper Kit</p> <ul style="list-style-type: none"> Includes trim and hardware Topper is 1/8" undersized from screen width for fit tolerance 1/4" radius corners For attachment to either Spine Screen or Flex Screens 	42" x 12"	TSTPA42	<input type="checkbox"/> <input type="checkbox"/> <input type="checkbox"/>	<input type="checkbox"/>		9.0#	\$ 480
	48" x 12"	TSTPA48	<input type="checkbox"/> <input type="checkbox"/> <input type="checkbox"/>	<input type="checkbox"/>		10.0#	548
	54" x 12"	TSTPA54	<input type="checkbox"/> <input type="checkbox"/> <input type="checkbox"/>	<input type="checkbox"/>		11.0#	557
	60" x 12"	TSTPA60	<input type="checkbox"/> <input type="checkbox"/> <input type="checkbox"/>	<input type="checkbox"/>		11.0#	679
	66" x 12"	TSTPA66	<input type="checkbox"/> <input type="checkbox"/> <input type="checkbox"/>	<input type="checkbox"/>		12.0#	687
	72" x 12"	TSTPA72	<input type="checkbox"/> <input type="checkbox"/> <input type="checkbox"/>	<input type="checkbox"/>		13.0#	755
	78" x 12"	TSTPA78	<input type="checkbox"/> <input type="checkbox"/> <input type="checkbox"/>	<input type="checkbox"/>		14.0#	763
	84" x 12"	TSTPA84	<input type="checkbox"/> <input type="checkbox"/> <input type="checkbox"/>	<input type="checkbox"/>		15.0#	1045
	90" x 12"	TSTPA90	<input type="checkbox"/> <input type="checkbox"/> <input type="checkbox"/>	<input type="checkbox"/>		16.0#	1055
	96" x 12"	TSTPA96	<input type="checkbox"/> <input type="checkbox"/> <input type="checkbox"/>	<input type="checkbox"/>		17.0#	1178
 <p>Polyester Felt Topper Kit</p> <ul style="list-style-type: none"> Includes trim and hardware Topper is 1/8" undersized from screen width for fit tolerance Square corners For attachment to either Spine Screen or Flex Screens 	42" x 12"	TSTPZ42		<input type="checkbox"/> <input type="checkbox"/> <input type="checkbox"/> <input type="checkbox"/>	<input type="checkbox"/>	5.0#	\$ 178
	48" x 12"	TSTPZ48		<input type="checkbox"/> <input type="checkbox"/> <input type="checkbox"/> <input type="checkbox"/>	<input type="checkbox"/>	6.0#	185
	54" x 12"	TSTPZ54		<input type="checkbox"/> <input type="checkbox"/> <input type="checkbox"/> <input type="checkbox"/>	<input type="checkbox"/>	6.0#	218
	60" x 12"	TSTPZ60		<input type="checkbox"/> <input type="checkbox"/> <input type="checkbox"/> <input type="checkbox"/>	<input type="checkbox"/>	7.0#	224
	66" x 12"	TSTPZ66		<input type="checkbox"/> <input type="checkbox"/> <input type="checkbox"/> <input type="checkbox"/>	<input type="checkbox"/>	7.0#	271
	72" x 12"	TSTPZ72		<input type="checkbox"/> <input type="checkbox"/> <input type="checkbox"/> <input type="checkbox"/>	<input type="checkbox"/>	8.0#	281
	78" x 12"	TSTPZ78		<input type="checkbox"/> <input type="checkbox"/> <input type="checkbox"/> <input type="checkbox"/>	<input type="checkbox"/>	8.0#	286
	84" x 12"	TSTPZ84		<input type="checkbox"/> <input type="checkbox"/> <input type="checkbox"/> <input type="checkbox"/>	<input type="checkbox"/>	9.0#	289
	90" x 12"	TSTPZ90		<input type="checkbox"/> <input type="checkbox"/> <input type="checkbox"/> <input type="checkbox"/>	<input type="checkbox"/>	9.0#	297
	96" x 12"	TSTPZ96		<input type="checkbox"/> <input type="checkbox"/> <input type="checkbox"/> <input type="checkbox"/>	<input type="checkbox"/>	10.0#	300

A

B

C

D

HOW TO ORDER

Indicate the following information on order form:

- Quantity of each item.
- Model number, including options. See "How To Build a Model Number".
- Any special service required.

Note: • The indicates that a choice is required.

- The absence of the indicates that no choice is required.
- Alpha-numeric characters in place of indicate that no other alternatives are available.

HOW TO BUILD A MODEL NUMBER

- A** Select basic model.
- B** Select acrylic color.
Refer to the **Product Color Options** page in this price list.
- C** Select polyester felt color.
Refer to the **Product Color Options** page in this price list.
- D** Select frame/trim color.
Refer to the **Product Color Options** page in this price list.

SPECIAL SERVICES

Special Carton Marking

With specially marked information N/C

Shipping

Ships **knocked down, FOB Manitowoc, WI 54220, freight prepaid**. Freight class 70.

Specifications and prices are subject to change without prior notice.

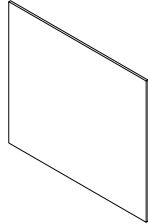
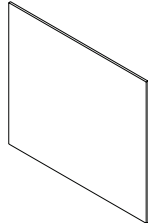

MODEL	W x H	MODEL NUMBER		Approx. Packaged Weight	Delivered Pricing
		Basic Model	Felt Color		
 <p>Solid Polyester Felt Magnetic Insert for 48" H Monolithic Screens</p> <ul style="list-style-type: none"> For specification with monolithic dry-erasable steel screens only Magnetic attachment May be attached and removed by user Pinnable felt is 1/2" thick Basic model indicates screen size Not offered on 42"H screens 	40 x 39"	TSMI4248	<input type="checkbox"/> <input type="checkbox"/> <input type="checkbox"/> <input type="checkbox"/>	7.0#	\$ 384
	46 x 39"	TSMI4848	<input type="checkbox"/> <input type="checkbox"/> <input type="checkbox"/> <input type="checkbox"/>	8.0#	384
	52 x 39"	TSMI5448	<input type="checkbox"/> <input type="checkbox"/> <input type="checkbox"/> <input type="checkbox"/>	9.0#	384
	58 x 39"	TSMI6048	<input type="checkbox"/> <input type="checkbox"/> <input type="checkbox"/> <input type="checkbox"/>	10.0#	384
	64 x 39"	TSMI6648	<input type="checkbox"/> <input type="checkbox"/> <input type="checkbox"/> <input type="checkbox"/>	11.0#	708
	70 x 39"	TSMI7248	<input type="checkbox"/> <input type="checkbox"/> <input type="checkbox"/> <input type="checkbox"/>	13.0#	708
	76 x 39"	TSMI7848	<input type="checkbox"/> <input type="checkbox"/> <input type="checkbox"/> <input type="checkbox"/>	14.0#	708
	82 x 39"	TSMI8448	<input type="checkbox"/> <input type="checkbox"/> <input type="checkbox"/> <input type="checkbox"/>	15.0#	708
	88 x 39"	TSMI9048	<input type="checkbox"/> <input type="checkbox"/> <input type="checkbox"/> <input type="checkbox"/>	16.0#	713
	94 x 39"	TSMI9648	<input type="checkbox"/> <input type="checkbox"/> <input type="checkbox"/> <input type="checkbox"/>	17.0#	713
TSMI					
 <p>Solid Polyester Felt Magnetic Insert for 54" H Monolithic Screens</p> <ul style="list-style-type: none"> For specification with monolithic dry-erasable steel screens only Magnetic attachment May be attached and removed by user Pinnable felt is 1/2" thick Basic model indicates screen size Not offered on 42"H screens 	40 x 45"	TSMI4254	<input type="checkbox"/> <input type="checkbox"/> <input type="checkbox"/> <input type="checkbox"/>	9.0#	\$ 384
	46 x 45"	TSMI4854	<input type="checkbox"/> <input type="checkbox"/> <input type="checkbox"/> <input type="checkbox"/>	10.0#	384
	52 x 45"	TSMI5454	<input type="checkbox"/> <input type="checkbox"/> <input type="checkbox"/> <input type="checkbox"/>	11.0#	384
	58 x 45"	TSMI6054	<input type="checkbox"/> <input type="checkbox"/> <input type="checkbox"/> <input type="checkbox"/>	12.0#	384
	64 x 45"	TSMI6654	<input type="checkbox"/> <input type="checkbox"/> <input type="checkbox"/> <input type="checkbox"/>	14.0#	708
	70 x 45"	TSMI7254	<input type="checkbox"/> <input type="checkbox"/> <input type="checkbox"/> <input type="checkbox"/>	15.0#	708
	76 x 45"	TSMI7854	<input type="checkbox"/> <input type="checkbox"/> <input type="checkbox"/> <input type="checkbox"/>	16.0#	708
	82 x 45"	TSMI8454	<input type="checkbox"/> <input type="checkbox"/> <input type="checkbox"/> <input type="checkbox"/>	17.0#	708
	88 x 45"	TSMI9054	<input type="checkbox"/> <input type="checkbox"/> <input type="checkbox"/> <input type="checkbox"/>	18.0#	713
	94 x 45"	TSMI9654	<input type="checkbox"/> <input type="checkbox"/> <input type="checkbox"/> <input type="checkbox"/>	19.0#	713
TSMI					

A

B

HOW TO ORDER

Indicate the following information on order form:

- Quantity of each item.
- Model number, including options. See "How To Build a Model Number".
- Any special service required.

Note: • The indicates that a choice is required.

- The absence of the indicates that no choice is required.
- Alpha-numeric characters in place of indicate that no other alternatives are available.

HOW TO BUILD A MODEL NUMBER

A Select basic model.

B Select felt color.
Refer to the **Product Color Options** page in this price list.

SPECIAL SERVICES

Special Carton Marking

With specially marked information N/C

Shipping

Ships **knocked down, FOB Manitowoc, WI 54220, freight prepaid**. Freight class 70.

Specifications and prices are subject to change without prior notice.

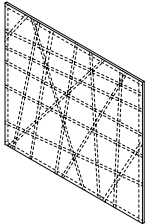
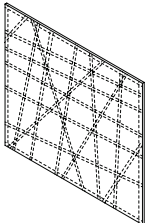

MODEL	W x H	MODEL NUMBER		Approx. Packaged Weight	Delivered Pricing
		Basic Model	Background/Foreground Felt Color		
 <p>Patterned Polyester Felt Magnetic Insert for 48”H Monolithic Screens</p> <ul style="list-style-type: none"> Basic model indicates screen size For specification with monolithic dry-erasable steel screens only Magnetic attachment May be attached and removed by user Pinnable felt is 5/8” thick Basic model indicates screen size Not offered on 42”H screens 	40 x 39”	TPMI4248	<input type="checkbox"/> <input type="checkbox"/> <input type="checkbox"/> <input type="checkbox"/> <input type="checkbox"/> <input type="checkbox"/>	7.0#	\$ 1196
	46 x 39”	TPMI4848	<input type="checkbox"/> <input type="checkbox"/> <input type="checkbox"/> <input type="checkbox"/> <input type="checkbox"/> <input type="checkbox"/>	8.0#	1196
	52 x 39”	TPMI5448	<input type="checkbox"/> <input type="checkbox"/> <input type="checkbox"/> <input type="checkbox"/> <input type="checkbox"/> <input type="checkbox"/>	9.0#	1196
	58 x 39”	TPMI6048	<input type="checkbox"/> <input type="checkbox"/> <input type="checkbox"/> <input type="checkbox"/> <input type="checkbox"/> <input type="checkbox"/>	10.0#	1654
	64 x 39”	TPMI6648	<input type="checkbox"/> <input type="checkbox"/> <input type="checkbox"/> <input type="checkbox"/> <input type="checkbox"/> <input type="checkbox"/>	11.0#	1654
	70 x 39”	TPMI7248	<input type="checkbox"/> <input type="checkbox"/> <input type="checkbox"/> <input type="checkbox"/> <input type="checkbox"/> <input type="checkbox"/>	13.0#	1654
	76 x 39”	TPMI7848	<input type="checkbox"/> <input type="checkbox"/> <input type="checkbox"/> <input type="checkbox"/> <input type="checkbox"/> <input type="checkbox"/>	14.0#	1654
	82 x 39”	TPMI8448	<input type="checkbox"/> <input type="checkbox"/> <input type="checkbox"/> <input type="checkbox"/> <input type="checkbox"/> <input type="checkbox"/>	15.0#	1654
	88 x 39”	TPMI9048	<input type="checkbox"/> <input type="checkbox"/> <input type="checkbox"/> <input type="checkbox"/> <input type="checkbox"/> <input type="checkbox"/>	16.0#	1663
	94 x 39”	TPMI9648	<input type="checkbox"/> <input type="checkbox"/> <input type="checkbox"/> <input type="checkbox"/> <input type="checkbox"/> <input type="checkbox"/>	17.0#	1663
TPMI					
 <p>Patterned Polyester Felt Magnetic Insert for 54”H Monolithic Screens</p> <ul style="list-style-type: none"> Basic model indicates screen size For specification with monolithic dry-erasable steel screens only Magnetic attachment May be attached and removed by user Pinnable felt is 5/8” thick Basic model indicates screen size Not offered on 42”H screens 	40 x 45”	TPMI4254	<input type="checkbox"/> <input type="checkbox"/> <input type="checkbox"/> <input type="checkbox"/> <input type="checkbox"/> <input type="checkbox"/>	9.0#	\$ 1196
	46 x 45”	TPMI4854	<input type="checkbox"/> <input type="checkbox"/> <input type="checkbox"/> <input type="checkbox"/> <input type="checkbox"/> <input type="checkbox"/>	10.0#	1196
	52 x 45”	TPMI5454	<input type="checkbox"/> <input type="checkbox"/> <input type="checkbox"/> <input type="checkbox"/> <input type="checkbox"/> <input type="checkbox"/>	11.0#	1196
	58 x 45”	TPMI6054	<input type="checkbox"/> <input type="checkbox"/> <input type="checkbox"/> <input type="checkbox"/> <input type="checkbox"/> <input type="checkbox"/>	12.0#	1654
	64 x 45”	TPMI6654	<input type="checkbox"/> <input type="checkbox"/> <input type="checkbox"/> <input type="checkbox"/> <input type="checkbox"/> <input type="checkbox"/>	14.0#	1654
	70 x 45”	TPMI7254	<input type="checkbox"/> <input type="checkbox"/> <input type="checkbox"/> <input type="checkbox"/> <input type="checkbox"/> <input type="checkbox"/>	15.0#	1654
	76 x 45”	TPMI7854	<input type="checkbox"/> <input type="checkbox"/> <input type="checkbox"/> <input type="checkbox"/> <input type="checkbox"/> <input type="checkbox"/>	16.0#	1654
	82 x 45”	TPMI8454	<input type="checkbox"/> <input type="checkbox"/> <input type="checkbox"/> <input type="checkbox"/> <input type="checkbox"/> <input type="checkbox"/>	17.0#	1654
	88 x 45”	TPMI9054	<input type="checkbox"/> <input type="checkbox"/> <input type="checkbox"/> <input type="checkbox"/> <input type="checkbox"/> <input type="checkbox"/>	18.0#	1663
	94 x 45”	TPMI9654	<input type="checkbox"/> <input type="checkbox"/> <input type="checkbox"/> <input type="checkbox"/> <input type="checkbox"/> <input type="checkbox"/>	19.0#	1663
TPMI					

A

B

HOW TO ORDER

Indicate the following information on order form:

- Quantity of each item.
- Model number, including options. See “How To Build a Model Number”.
- Any special service required.

Note: • The indicates that a choice is required.

- The absence of the indicates that no choice is required.
- Alpha-numeric characters in place of indicate that no other alternatives are available.

HOW TO BUILD A MODEL NUMBER

- A** Select basic model.
- B** Select background/foreground felt color. Refer to the **Product Color Options** page in this price list.

SPECIAL SERVICES

Special Carton Marking



With specially marked information N/C

Shipping

Ships **knocked down, FOB Manitowoc, WI 54220, freight prepaid**. Freight class 70.

Specifications and prices are subject to change without prior notice.

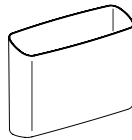

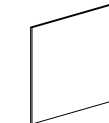
MODEL	W x H x D	MODEL NUMBER			Approx. Packaged Weight	Delivered Pricing	Delivered Pricing Fabric Grade 1 & C.O.M.	Delivered Pricing Fabric Grade 2	Delivered Pricing Fabric Grade 3 & Pallas Vertical Fabric Grade PV	Delivered Pricing Pallas Vertical Fabric Grade PV1	Delivered Pricing Pallas Vertical Fabric Grade PV2
		Basic Model	Color	Fabric Color							
 <p>Binder Bin</p> <ul style="list-style-type: none"> Limited inventory, please communicate with your Sales Ops Coordinator to ensure enough inventory for your projects 	10x13x3"	TSMABB	<input type="checkbox"/>		2.00#	\$ 58					
AC909											
 <p>Shelf</p> <ul style="list-style-type: none"> Limited inventory, please communicate with your Sales Ops Coordinator to ensure enough inventory for your projects 	10 x 5 x 4"	TSMAS	<input type="checkbox"/>		1.00#	\$ 28					
AC909											
 <p>Magnetic Tackboard Tiles</p> <ul style="list-style-type: none"> Tackable surface Magnetic attachment to dry-erasable steel core only Limited inventory, please communicate with your Sales Ops Coordinator to ensure enough inventory for your projects 	18 x 18 x 1/2"	TTB1818		<input type="checkbox"/> <input type="checkbox"/> <input type="checkbox"/> <input type="checkbox"/>	5.00#	N/A	\$ 260	\$ 268	\$ 277	\$ 286	\$ 294
	18 x 24 x 1/2"	TTB1824		<input type="checkbox"/> <input type="checkbox"/> <input type="checkbox"/> <input type="checkbox"/>	6.00#	N/A	281	288	299	304	315
	24 x 24 x 1/2"	TTB2424		<input type="checkbox"/> <input type="checkbox"/> <input type="checkbox"/> <input type="checkbox"/>	7.00#	N/A	301	306	319	325	334
TTB											

A **B** **C**

HOW TO ORDER

- Indicate the following information on order form:
- Quantity of each item.
 - Model number, including options. See "How To Build a Model Number".
 - Any special service required.

Note:

- The indicates that a choice is required.
- The absence of the indicates that no choice is required.
- Alpha-numeric characters in place of indicate that no other alternatives are available.

HOW TO BUILD A MODEL NUMBER

- A** Select basic model.
- B** Select color. Refer to the **Product Color Options** page in this price list.
- C** Select fabric color. Refer to ki.com/fabrics

SPECIAL SERVICES

Special Carton Marking



With specially marked information N/C

Shipping

Ships **knocked down, FOB Manitowoc, WI 54220, freight prepaid.** Freight class 70.

Specifications and prices are subject to change without prior notice.

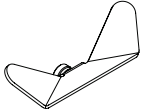

MODEL	W x H	MODEL NUMBER			Approx. Packaged Weight	Delivered Pricing	Delivered Pricing Fabric Grade 1 & C.O.M.	Delivered Pricing Fabric Grade 2	Delivered Pricing Fabric Grade 3 & Pallas Vertical Fabric Grade PV	Delivered Pricing Pallas Vertical Fabric Grade PV1	Delivered Pricing Pallas Vertical Fabric Grade PV2
		Basic Model	Color	Fabric Color							
 Coat Hook • Formed powder-coated steel • Attaches with flat head allen screw to slotting below upper screen trim TTA04		TWSCH	<input type="checkbox"/>		2.00#	\$ 44					
 Sliding Dual-Purpose Board • Side A is magnetic dry-erasable steel • Side B is tackable fabric; fabric direction is always railroaded • Anodized aluminum trim • Attaches to and slides along slotting below upper screen trim • Reversible by user • Cannot be specified for use on Segment-ed Flex Screens TSDPB	24 x 38.5"	TSDPB		<input type="checkbox"/> <input type="checkbox"/> <input type="checkbox"/> <input type="checkbox"/>	15.00#	N/A	\$ 244	\$ 250	\$ 258	\$ 261	\$ 271
		A	B	C							

HOW TO ORDER

- Indicate the following information on order form:
- Quantity of each item.
 - Model number, including options. See "How To Build a Model Number".
 - Any special service required.

Note:

- The indicates that a choice is required.
- The absence of the indicates that no choice is required.
- Alpha-numeric characters in place of indicate that no other alternatives are available.

HOW TO BUILD A MODEL NUMBER

- A** Select basic model.
- B** Select color. Refer to the **Product Color Options** page in this price list.
- C** Select fabric color. Refer to ki.com/fabrics

SPECIAL SERVICES

Special Carton Marking

With specially marked information N/C

Shipping

Ships **knocked down, FOB Manitowoc, WI 54220, freight prepaid.** Freight class 70.

Specifications and prices are subject to change without prior notice.



Pedestal with Cushion Top



Tower, Left Wardrobe



Tower, Right Wardrobe



Vanity, Laminate Top, Left Cupboard



Vanity, Steel Top, Right Cupboard



Low Cupboard



Low Cupboard with Raised Worktop



Low Cupboard with Raised Worktop, Adjustable Screen



Chest

Features					
Casters	•	•	•	•	•
Glides		•	•	•	•
5 pull options	•	•	•	•	•

Features				
Casters	•	•	•	•
Glides	•	•	•	•
5 pull options	•	•	•	

Locks

Locks are standard on all units. Locks are a high-security double-bit design. Two KI break-away keys are included with each lock. Units are standard with random keys in a range of 200 different numbers (994 key numbers are available to order).

Locks can be master keyed. Please see the accessories sections of this price book for ordering keys. Available keys are:

- Lock Core/Keys - Lock core and 2 keys are used in P-Series lock housings.
- Master Key - Single key which opens any P-Series lock.
- Extractor Key - Single key which extracts any P-Series lock core.
- Blank Key - Single uncut P-Series key to be cut as required by locksmith.
- Cut Key - 2 keys for a specific P-Series lock core number as indicated in the order notes.

installed or shipped separately. To remove lock plugs, a unique key is required. This key is the extractor (core-removal) key and can be found in the storage accessories portions of this price book. Contact customer service to order lock accessories. To order plugs for field installation, specify "no lock core (NLC)" when configuring. Order must specify total quantity of specific key numbered locks.

Example: 30 plugs
3 keyed alike
10 keyed alike
17 keyed alike

All locks have removable and interchangeable plugs. This feature provides for on-site custom keying. Units can be supplied with the lock plugs

INFORMATION

Warranty

Refer to KI Terms & Conditions document or visit ki.com



PRODUCT SPECIFICATIONS ■

Tattoo™ Storage

June 2023

TECHNICAL SPECIFICATIONS

Construction & Standard Features

All Tattoo storage units are constructed primarily of steel, which is powder-coat painted in standard KI colors. Drawers feature smooth rolling, steel ball-bearing extension slides. Chest, low cupboard, vanity and tower units are supported off the floor by leg posts of 16-gauge steel which are welded to 1/4" thick steel mounting plates and include either a caster or glide option. Leg post lengths are different for either casters or glides to accomplish a uniform 7" distance from the underside of the unit to the floor. Optional 1 1/8" diameter nylon leveling glides allow for height-adjustability of approximately 3/4". Optional 1 1/2" diameter twin-wheel swiveling casters are constructed of soft non-marking plastic, in a set of two locking and two non-locking wheels. Mobile pedestal is standard with casters only, two locking and two non-locking with one additional non-locking caster at the bottom of the lower drawer front for stability. All storage units are stand-alone units.

Tattoo Storage Finish

Tattoo storage is offered in all standard KI powder-coat finishes. Powder-coat application is a hybrid epoxy, baked on to provide a scratch and stain resistant finish. Doors, drawer fronts, steel lids and locking filler rails (on vanity units) may be specified in different colors than the shell at no up charge. Mechanical components are nickel-chrome plated or finished with other protective coatings. Legs are powder-coated the same finish as the shells.

Tattoo Pulls

All Tattoo storage drawers and doors can be ordered to receive either cast metal Connection Zone, arc or beveled style pulls in select metallic finishes. Woven nylon strap pulls are available as well, and come in black or silver tone.

Tattoo Locks

Tattoo storage ships standard with high security double-bit locks, with master key-able P-Series lock cores. The locks are randomly keyed and can be specified with or without lock cores. Wardrobe and vanity units contain multiple locks but will be keyed alike for each entire unit. Locks are available in black chromate and satin chrome finishes.

Optional Seat Pads & Padded Topper

The mobile pedestal and low cupboard are offered with optional loose seat pads. The chest ships with a standard fixed padded topper. Pads are upholstered in a selection of fabrics. Total pad thickness is 1 1/4", consisting of 3/4" polyurethane foam of 2.0 average density, 100 average IFD, and glued to 1/2" particle board. Loose seat pad bottoms have rubberized non-skid strips to protect surface finishes. Fixed padded toppers are fastened to the steel storage tops using steel machine screws into inserts in the particle board base.

Storage Door/Lid Hinges

Cupboard, wardrobe, vanity doors and lid each use two Euro-style "hidden hinges" for a seamless finish. The chest utilizes a piano-style hinge for maximum durability as a seating surface. Vanity and chest lids also feature two soft close lid stays for ease of use and silent operation.

Compliance

Tattoo storage is designed and manufactured to meet or exceed required ANSI/BIFMA x5.9-2012.



Mobile Pedestal

Mobile pedestal outer upper shell construction is of 20-gauge steel with an 18-gauge steel bottom pan. The primary drawer is constructed of 22-gauge steel and comes standard with side-to-side filing for letter and legal-sized folders. Primary drawer front features an internal pencil drawer behind the drawer front. The hidden drawer is constructed of 20-gauge steel.

Chest

Chest top and sides construction is of 20-gauge steel. Folder rails, bottom pan and its reinforcements are made from 18-gauge steel. Chest allows for side-to-side filing of legal size paper, with folder bars included for front-to-back filing of letter and legal-sized paper. An additional pair of folder bars may be ordered separately to file a second set of letter or legal sized paper front-to-back. Chest lid features two soft-closing hinges for ease of use and silent operation of the lid. All chest units are standard with an upholstered padded topper to act as a sitting surface.

Low Cupboard

Low cupboard case construction is of 20-gauge steel. The shell's top reinforcement, bottom pan and its reinforcements are made from 18-gauge steel. Unit is available with a steel top, or with optional 3/4" thick raised worktop of HPL laminated particleboard, with a 2 mm (73P) edge. Raised worktop is supported by .060" thick wall aluminum tubing, allowing for 4 1/2" of clearance between the worktop underside and the top of the unit shell. Raised worktop low cupboard units are also available with a height-adjustable, 1/2" thick polyester felt screen. The screen has a density of 0.5 lb/ft² and is sound absorbing tested to ASTM C423 with an NRC rating of .44 when using no air gap (a mount testing method) and an NRC rating of .81" with 2" air gap. The polyester felt is in accordance with ASTM-E84 and achieve a Class A Flame Spread. Screen is raised/lowered by hand and is 44 1/2" high when fully raised. Felt screen mechanism lowers the screen top to be flush with the worktop surface.

Vanity

Vanity case construction is of 20-gauge steel. The bottom pan and its reinforcements are made from 18-gauge steel. Drawer fronts are constructed of 20-gauge steel, with 18-gauge steel reinforcements. The primary drawer back is constructed of 18-gauge steel. The cupboard door and shelf are constructed of 22-gauge steel.

The vanity has a flip-up lid to provide additional privacy. The hinged lid has two soft closing hinges for ease of use and silent operation. Lids are available in 18-gauge steel, or laminated particleboard construction. The lid includes a white markerboard surface at the underside. The 3/4" laminated particleboard lid has HPL laminate on top, a white markerboard backer surface underneath, a 2 mm (73P) edge and a standard nylon strap pull. A storage space is located below either lid type, with a full-size felt pad to help gently store items.

The vanity cupboard door is either right- or left-hand and determines the hand of the unit. A right-hand unit features a cupboard door on right side of the unit. Inside the vanity cupboard is a removable shelf. The main drawer body is constructed with side access oriented towards the cupboard door. The drawer incorporates a stow-able folder bar, which can be moved out of the way for improved drawer access, or be used to allow front-to-back filing of letter sized paper. A pencil drawer is hidden behind the main drawer front for improved utility and aesthetics. Unit can be ordered with grommets in the upper lid shelf, 1 7/8" overall clearance diameter with a 3/4" diameter cord pass through and the rear cupboard grommet with 1 5/8" overall clearance through to route wires. Grommet will be located on the cupboard side.

Tower

Tower case construction is of 20-gauge steel. The bottom pan and its reinforcements are made from 18-gauge steel. Drawer fronts and wardrobe door are constructed of 22-gauge steel. The drawer bodies and backs are constructed of 18-gauge steel. Unit features a pedestal in file/file or box/box/file configuration. File drawers may be filled with letter sized paper front-to-back, or letter or legal sized paper side-to-side. A front- and side-accessible storage shelf is located above the pedestal. The location of the full vertical-height wardrobe, with coat rod bracket and boot tray determine the hand of the unit. A right-hand unit features the wardrobe on the right side of the unit.

Mobile Pedestal

External Pedestal Dimensions	Internal File Drawer Dimensions	Internal Hidden Drawer Dimensions
External Height: 19"	Internal Height: 12 ¹ / ₄ "	Internal Height: 2"
External Width: 12"	Internal Width: 9"	Internal Width: 9"
External Depth: 18"	Internal Depth: 16 ¹ / ₄ "	Internal Depth: 16"

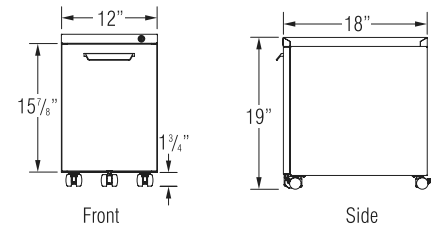

External Chest Dimensions	Internal Chest Dimensions
External Height: 20 ³ / ₈ "	Internal Height: 11 ¹ / ₄ "
External Width: 36"	Internal Width: 34 ¹ / ₂ "
External Depth: 18"	Internal Depth: 15"

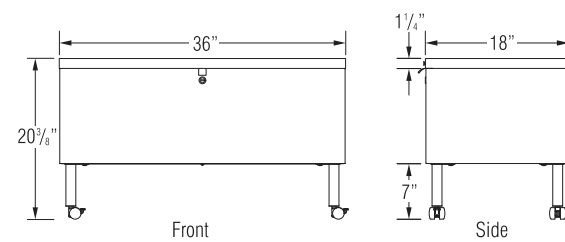

Low Cupboard

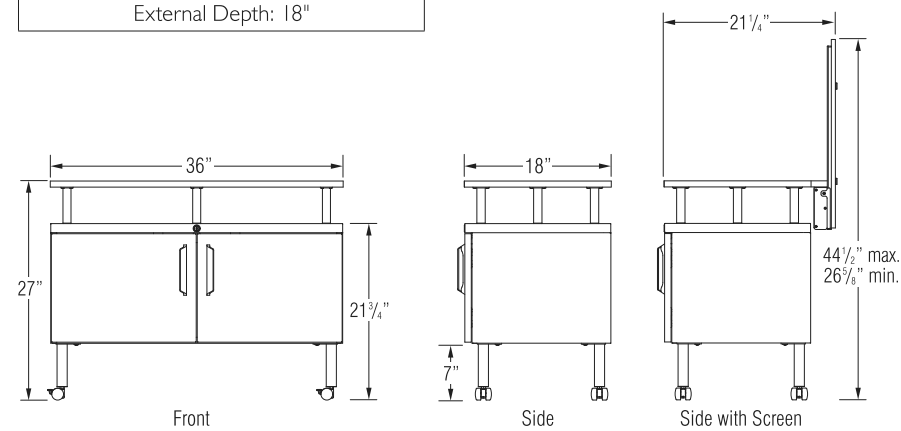
External Low Cupboard Dimensions	Internal Low Cupboard Dimensions
Steel Top Height: 21 ³ / ₄ "	Internal Height: 12 ³ / ₄ "
Raised Worktop Height: 27"	Internal Width: 34 ¹ / ₂ "
External Width: 36"	Internal Depth: 17"
External Depth: 18"	

Tower

External Tower Dimensions
External Height: 46"
External Width: 24"
External Depth: 22"

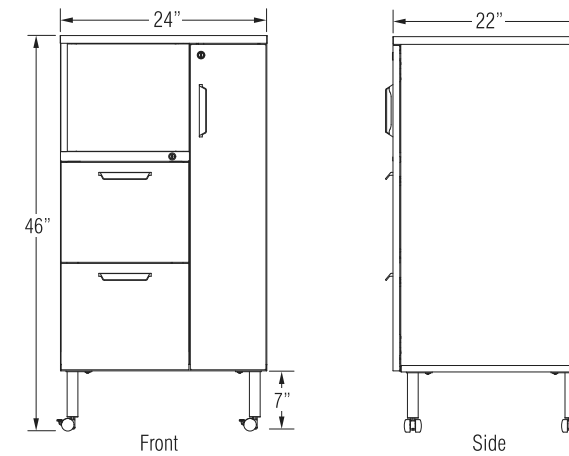
Internal Box Drawer Dimensions	Internal File Drawer Dimensions	Internal Open Storage Dimensions	Internal Wardrobe Dimensions
Internal Height: 5 ¹ / ₈ "	Internal Height: 11"	Internal Height: 12 ¹ / ₂ "	Internal Height: 37 ³ / ₈ "
Internal Width: 12"	Internal Width: 12"	Internal Width: 14 ¹ / ₈ "	Internal Width: 7 ³ / ₈ "
Internal Depth: 15 ¹ / ₂ "	Internal Depth: 15 ¹ / ₂ "	Internal Depth: 20 ³ / ₈ "	Internal Depth: 21"
Linear Coat Hook Space: 4 ¹ / ₂ "			

Vanity

External Vanity Dimensions
External Height: 29 ⁷ / ₈ "
External Width: 24"
External Depth: 22"

Internal Pencil Drawer Dimensions	Internal File Drawer Dimensions	Internal Lid Storage Dimensions	Internal Cupboard Dimensions
Internal Height: 2 ³ / ₄ "	Internal Height: 14 ¹ / ₂ "	Internal Height: 1 ¹ / ₄ "	Internal Height: 18 ⁵ / ₈ "
Internal Width: 12"	Internal Width: 12"	Internal Width: 22 ¹ / ₂ "	Internal Width: 8 ¹ / ₄ "
Internal Depth: 15 ³ / ₈ "	Internal Depth: 17 ¹ / ₂ "	Internal Depth: 19"	Internal Depth: 21"
Internal Height with Shelf: 8 ⁷ / ₈ " above / below shelf			
Internal Shelf Depth: 18 ¹ / ₄ " with a 2" clearance behind to route cables			

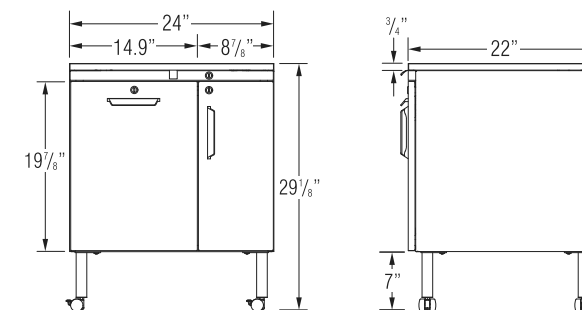



Storage

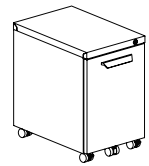

TSPD
Pedestal

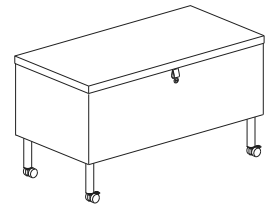

TSCH
Chest

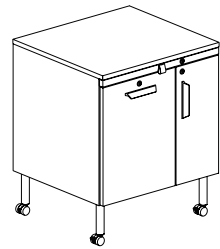

TSPA
Vanity

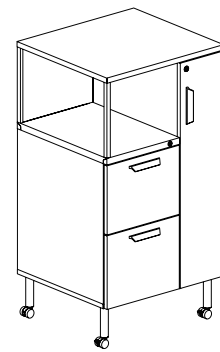

TSTW
Tower

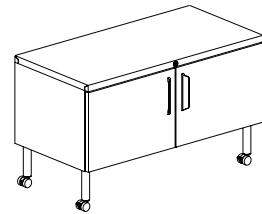

TSCB CS
Low Cupboard

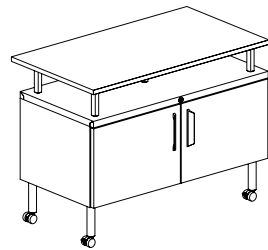

TSCM CW
Low Cupboard
with Raised Worksurface

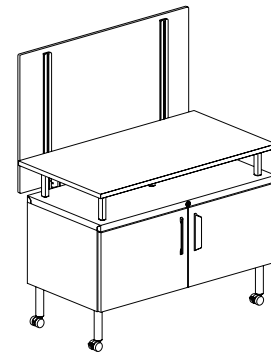

TSCB CWS
Low Cupboard
with Adjustable Screen

Pulls

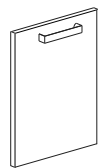

CZP
128mm
Nickle
Connection
Zone Pull

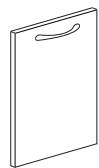

ARCN
128mm
Nickle
Arc Pull

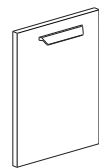

S5/S6
128mm
Black/Satin Chrome
Beveled Pull

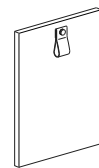

SSR/SBL
38mm W x 83mm L
Black/Silver
Strap Pull

Glides

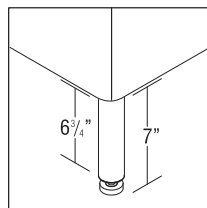

Glide Leg Option

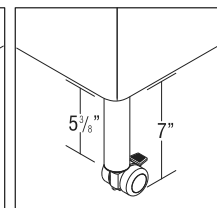

Caster Leg Option

Customer's Own Material ■

Specifications Form

January 2023

How to Specify

As a standard procedure, KI applies seating upholstery as swatched by the textile distributor. Reference distributor's website. Upholstery that is required to be applied differently than is swatched, will need a Product Modification Request written specifying the direction the upholstery is to be applied.

Seating upholstery requiring specific positioning of intricate patterns or patterns repeats on seats and backrests, will need a Product Modification Request written including a sketch noting the specific requirements, as in Diagram A.

C.O.M. must be supplied in continuous yardage.

Yardage requirements listed in price list are based on plain goods 54" wide. Fabrics less than 54" wide, or those requiring matching (stripes, plaids, prints, large patterns) will require additional yardage based on the fabric used and the item ordered. Consult matrix below for additional yardage needed.

C.O.M. INCREASE MATRIX (yardage matrix is also applicable to any reservations of KI Ingrade, Pallas, or K.O.M. upholsteries).

This table is a general guide.

FABRIC WIDTH	PLAIN	UNDER 7"	8"-13"	14"-21"	22"-27"	28"-33"	34"-40"	41"-48"
	FABRIC	REPEAT	REPEAT	REPEAT	REPEAT	REPEAT	REPEAT	REPEAT
54"	0	20%	25%	30%	45%	55%	70%	80%
51"-53"	15%	25%	30%	35%	50%	60%	80%	90%
48"-50"	20%	30%	35%	40%	55%	65%	85%	95%
45"-47"	30%	45%	50%	55%	60%	80%	90%	100%
36"-44"	50%	65%	70%	75%	80%	100%	110%	120%

Fabric with double repeat: If using a fabric with a double repeat, please follow this formula: take the total amount of the larger and half of the smaller repeat; add together to find the correct overall repeat. Example: 10" vertical with 14" horizontal would be 14+5=19.

If fabric comes in on multiple rolls, one additional yard per roll needs to be added to the yardage requirement.

Leather hides must be a minimum of 50 square feet of usable material. The outer edges cannot be calculated as square feet or yardage. To determine square footage, multiply unit yardage by 18 square feet to obtain the total square footage required per unit.

For exact production yardage requirements, call 1-800-424-2432, ext. 2707.

Production

Customer's upholstery must be approved prior to acceptance for production.

After approval, a memo swatch of the C.O.M. from the textile distributor must accompany the order. KI assumes no responsibility for wear, defects, or performance of C.O.M. or K.O.M. upholstery.

C.O.M. not received into the appropriate facility 3 weeks prior to acknowledged delivery date may go on hold. See KI C.O.M. Shipping Location listing for the correct facility address by product.

All C.O.M. must be labeled as follows:

1. Name and address
2. Your purchase order number
3. Our style number to which fabric is to be applied
4. Supplier name and fabric name, number, and color

ALL C.O.M. Shipments must be prepaid. Collect shipments will be refused.

Testing

When KI requires testing, actual yardage to upholster one chair may be required. The C.O.M. Specialist will confirm model and fabric testing requirements when applicable.

Approved test samples will be applied to the order or will be held for 6 months. After 6 months, the sample will no longer be applied to your order. For all product testing, send fabric samples to the manufacturing facility. See KI C.O.M. Shipping Location listing for the correct facility address by product.

ALL C.O.M. Shipments must be prepaid. Collect shipments will be refused.

Treated Materials

If C.O.M. requires processing such as a stain resistance treatment or acrylic backing, it may shrink. To prevent delays in delivery or back ordering due to shrinkage, please have your processor verify measurement after processing and assure adequate yardage shipped.

Split Orders

If a portion of the shipment which does not require C.O.M. application is to be processed and shipped early, KI will enter the order immediately at your request. These split shipments are subject to minimum order changes.

Excess Upholstery Material

KI will dispose of excess upholstery material at the time of shipment unless expressly requested to return it with the product shipment.

Cancelled or Changed Orders

KI assumes no responsibility for extra C.O.M. due to a change of upholstery or cancellation of an order. If it the customer's responsibility to arrange for return of the material.

Contact the C.O.M. Specialist at 1-800-424-2432, ext. 2707, with questions or to request a split order

Diagram A

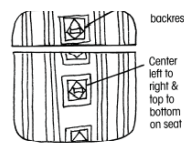

Surface Finish--Grade 1 Standard Laminate

Beigewood
Belair
Biltmore Cherry
Black
Brighton Walnut
Castle Oak
Cherry Storm
Classic Linen
Cocobala
Crisp Linen
Designer White
Dove Grey
Florence Walnut
Friston Ash
Frosty White
Graphite Nebula
Grey
High Rise
Hollyberry
Island
Italian Silver Ash
Kensington Maple
Lapis Blue
Monticello Maple
North Sea
Ocean
Pinnacle Walnut
River Cherry
Shadow Zephyr
Sterling Ash
Titanium Evolv
White Nebula
White Sand
Windsor Mahogany

Surface Finish--Grade 2 Standard Laminate

Akira
Black Alicante
Black Hills Oak
Calcutta Marble
Dering Forest
Fawn Cypress
Ice Mist
Markerboard White
Valley Forge Elm
White River Forest

Surface Finish--Grade 3 Standard Laminate

Black Velvet
Cumberland Walnut
Designer White Velvet
Hartley Walnut
Nile Velvet
Raleigh Walnut
Solano Walnut
Spruce Velvet

Edge Color for 73P Edge Style

LBZ Akira
LBQ Beigewood
LBT Belair
LBK Biltmore Cherry
LBW Black
LCO Black Hills Oak
LCX Blue Grey
LCI Brighton Walnut
LCC Castle Oak
LRI Cayenne
LDR Cherry Storm
LDG Cocobala
LFC Cool Grey
LFH Cumberland Walnut
LFW Dering Forest
LGN Designer White
LGE Everglade Shade
LHE Fawn Cypress
LHY Flannel
LID Florence Walnut
LIT Friston Ash
LKM Frosty White
LLB Hartley Walnut
LMT Hazy Jade
LNA Italian Silver Ash
LON Kensington Maple
LPW Light Tone
LRY Mardi Gras
LSR Misty Brown
LAZ Monticello Maple
LTV Multiplex
LWL Nemo
LWN Pinnacle Walnut
LWY Poppy Red

LAK Raleigh Walnut
LBY River Cherry
LBH Rubber Ducky
LCQ Sand
LDF Sky Blue
LDQ Solano Walnut
LIM Sterling Ash
LMK Surf's Up
LVF Tarragon
LWR Twilight Shadow
Valley Forge Elm
Warm Grey
White River Forest
Windsor Mahogany
Zesty Lime

Top Paint Color

LRW Black
LSG Blue Grey
LSC Bronze Metallic
Cayenne

EAK Champagne Metallic
EBZ Cool Grey
EBQ Cottonwood
EBT Earthen Clay
EBL Espresso Metallic
EBH Everglade Shade
EGR Flannel
EBW Glitz Metallic
ECO Hazy Jade
ECY Honey Bee
ECX Light Tone
ECX Mardi Gras
ECC Misty Brown
ECG Nemo
ECJ Nordic
EDF Poppy Red
EDR Purple Haze
EEV Rainforest
EFQ Raw Jasper
EFN Rubber Ducky
EFC Sand
EFH Sky Blue
EFW Starlight Silver Metallic
EHW Surf's Up
HJ Tarragon
EIT Twilight Shadow
EKM Ultra Blue
ELG Warm Grey
EMG Zesty Lime

Shell Paint Color

EMB Black
ENE Blue Grey
EPW Bronze Metallic
EPR Cayenne
ERQ Champagne Metallic
ERW Cool Grey
ERY Cottonwood
ERK Earthen Clay
ESA Espresso Metallic
ESK Everglade Shade
ESG Flannel
EAZ Glitz Metallic
ESP Hazy Jade
ETQ Honey Bee
ETI Light Tone
EUB Mardi Gras
EVF Misty Brown
EWG Nemo
EWR Nordic
EWY Poppy Red
EZL Purple Haze
Rainforest
Raw Jasper
Rubber Ducky
Sand
Sky Blue
Starlight Silver Metallic

TTCM Surf's Up
TTCG Tarragon
TTCO Twilight Shadow
TTEY Ultra Blue
TTEV Warm Grey
TTEV Zesty Lime
TTFN
TTGZ
TTHJ
TTHY
TTLG
TTMG
TTMY
TTNE
TTND
TTPR
TTPH
TTRQ
TTRJ
TTRK
TTSA
TTSK
TTSX
TTSP
TTTQ
TTTI
TTUB
TTWG
TTZL

BL Black
GR Blue Grey
ZM Bronze Metallic
CY Cayenne
CM Champagne Metallic
CG Cool Grey
CO Cottonwood
EY Earthen Clay
EX Espresso Metallic
EV Everglade Shade
FN Flannel
GZ Glitz Metallic
HJ Hazy Jade
HY Honey Bee
LG Light Tone
MG Mardi Gras
MY Misty Brown
NE Nemo
ND Nordic
PR Poppy Red
PH Purple Haze
RQ Rainforest
RJ Raw Jasper
RK Rubber Ducky
SA Sand
SK Sky Blue
SX Starlight Silver Metallic

Locking filler rail is painted the same color as the door and drawer fronts.

Lock Color

LG Satin Chrome
MG Black

Strap Pull Color

NE Black
ND Silver

Screen Felt Color

RQ Dandelion
RJ Fawn
RK Flannel
SA Heather
SK Lava
SX

SP Mallard
TQ Midnight Blue
TI Pepper
UB Spring
WG Tidal Wave
ZL

Door/Drawer Paint Color

FBL Black
FGR Blue Grey
FZM Bronze Metallic
FCY Cayenne
FCM Champagne Metallic
FCG Cool Grey
FCO Cottonwood
FEY Earthen Clay
FEX Espresso Metallic
FEV Everglade Shade
FFN Flannel
FGZ Glitz Metallic
FHJ Hazy Jade
FHY Honey Bee
FLG Light Tone
FMG Mardi Gras
FMY Misty Brown
FNE Nemo
FND Nordic
FPR Poppy Red
FPH Purple Haze
FRQ Rainforest
FRJ Raw Jasper
FRK Rubber Ducky
FSA Sand
FSK Sky Blue
FSX Starlight Silver Metallic
FSP Surf's Up
FTQ Tarragon
FTI Twilight Shadow
FUB Ultra Blue
FWG Warm Grey
FZL Zesty Lime



Finish Cards

View color swatches for items listed within this document.

Paints
Plastics/Poly
Wood/Veneer
Laminates
Molded Edges
Edge Styles
Hard Plastics
Glass

Certain options referenced may not be available on GSA Schedule.

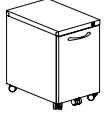

	MODEL	W x D x H	MODEL NUMBER								Approx. Packaged Weight	Delivered Pricing	Delivered Pricing Fabric Grade 1 & C.O.M.	Delivered Pricing Fabric Grade 2	Delivered Pricing Fabric Grade 3	Delivered Pricing Vinyl Group 2V	Delivered Pricing Pallas Fabric Group P0	Delivered Pricing Pallas Fabric Group P1	Delivered Pricing Pallas Fabric Group P2	Delivered Pricing Pallas Fabric Group P3	Delivered Pricing Pallas Fabric Group P4	
			Basic Model	Pull Style	Shell Color	Door/Drawer Front Color	Pull Color	Lock Option	Lock Color	Upholstery Color												
 <p>Arc pull shown</p> <p>TSPD</p>	Mobile File with Pencil Drawer • Large drawer for files or personal items • Large drawer houses 1-1/2" hidden inner pencil drawer • Steel shell and steel front • 5th wheel in lieu of counterbalance weight • Optional pad specified separately	12 x 18 x 19"	TSPD1218MF	<input type="checkbox"/>	<input type="checkbox"/>	<input type="checkbox"/>	<input type="checkbox"/>	<input type="checkbox"/>	<input type="checkbox"/>	<input type="checkbox"/>		38.00#	\$ 657									
 <p>TSPP</p>	Pedestal Pad • Constructed of 3/4" thick foam and medium density fiberboard for a total thickness of 1-1/4" • Non-slip pads on underside • Fabric runs side-to-side • COM = .75 yd	12 x 18 x 1-1/4"	TSPP1218								<input type="checkbox"/>	0.00#	N/A	\$ 117	\$ 129	\$ 130	\$ 130	\$ 133	\$ 140	\$ 151	\$ 151	\$ 163
			A	B	C	D	E	F	G	H												

HOW TO ORDER

- Indicate the following information on order form:
- Quantity of each item.
 - Model number, including options. See "How To Build a Model Number".
 - Any special service required.

Note:

- The indicates that a choice is required.
- The absence of the indicates that no choice is required.
- Alpha-numeric characters in place of indicate that no other alternatives are available.

HOW TO BUILD A MODEL NUMBER

- A** Select basic model.
- B** Select pull style.
 - ARC** - Arc pull
 - S6** - Beveled pull Black
 - S5** - Beveled pull Satin Chrome
 - STP** - Strap pull
 - CZP** - Nickel Rectangle (Connection Zone) pull
- C** Select shell color. Refer to the **Product Color Options** page in this price list.
- D** Select drawer color. Refer to the **Product Color Options** page in this price list.
- E** Select pull color. Select if Strap pull (STP) is selected.
 - SBL** - Black
 - SSR** - Silver
 Refer to the **Product Color Options** page in this

- price list.
- F** Select lock option.
 - KS** - Key standard - 1 lock
 - NLC** - No lock core - 1 lock
 - G** Select lock color. Refer to the **Product Color Options** page in this price list.
 - BLL** - Black
 - SCL** - Satin Chrome
 - H** Select upholstery color. Refer to ki.com/fabrics

SPECIAL SERVICES

Special Carton Marking

With specially marked information N/C

Shipping

Ships assembled, FOB Pembroke, ON K8A 0E1, freight prepaid and High Point, NC 27263. Freight class 100.

Specifications and prices are subject to change without prior notice.

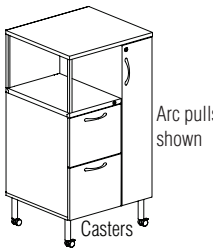
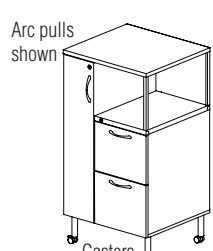
MODEL	W x D x H	MODEL NUMBER								Approx. Packaged Weight	Delivered Pricing	
		Basic Model	Pull Style	Base	Shell Color	Door/Drawer Front Color	Pull Color	Lock Option	Lock Color			
 <p>Right Facing Wardrobe - Left Facing Shelf/File/File Tower</p> <ul style="list-style-type: none"> Wardrobe and file lock independently Two 12" file drawers Open shelf large enough to hold binders Available with casters or glides Wardrobe includes hanger bar and boot tray Legs field installed 	24 x 22 x 46"	TSTW2439FF9RW	<input type="checkbox"/>	<input type="checkbox"/>	<input type="checkbox"/>	<input type="checkbox"/>	<input type="checkbox"/>	<input type="checkbox"/>	<input type="checkbox"/>	141.0#	\$ 2044	
 <p>Left Facing Wardrobe - Right Facing Shelf/File/File Tower</p> <ul style="list-style-type: none"> Wardrobe and file lock independently Two 12" file drawers Open shelf large enough to hold binders Available with casters or glides Wardrobe includes hanger bar and boot tray Legs field installed 	24 x 22 x 46"	TSTW2439FF9LW	<input type="checkbox"/>	<input type="checkbox"/>	<input type="checkbox"/>	<input type="checkbox"/>	<input type="checkbox"/>	<input type="checkbox"/>	<input type="checkbox"/>	141.0#	\$ 2044	
			A	B	C	D	E	F	G	H		

HOW TO ORDER

- Indicate the following information on order form:
- Quantity of each item.
 - Model number, including options. See "How To Build a Model Number".
 - Any special service required.

Note:

- The indicates that a choice is required.
- The absence of the indicates that no choice is required.
- Alpha-numeric characters in place of indicate that no other alternatives are available.

HOW TO BUILD A MODEL NUMBER

- A** Select basic model.
- B** Select pull style.
- ARCN** - Arc pull
- S6** - Beveled pull Black
- S5** - Beveled pull Satin Chrome
- STP** - Strap pull
- CZP** - Nickel Rectangle (Connection Zone) pull
- C** Select base option.
- 4CR** - 4 black casters (2 locking)
- 4GL** - 4 black glides
- D** Select shell color.
Refer to the **Product Color Options** page in this price list.
- E** Select door/drawer color.
Refer to the **Product Color Options** page in this price list.
- F** Select pull color.

- Select if Strap Pull (STP) is selected.
- SBL** - Black
- SSR** - Silver
- Refer to the **Product Color Options** page in this price list.
- G** Select lock option.
- KS** - Key standard - 2 locks
- NLC** - No lock core - 2 locks
- H** Select lock color.
- BLL** - Black
- SCL** - Satin Chrome
- Refer to the **Product Color Options** page in this price list.

SPECIAL SERVICES**Special Carton Marking**

With specially marked information N/C

Shipping

Ships assembled, FOB Pembroke, ON K8A 0E1, freight prepaid. Freight class 100.

Specifications and prices are subject to change without prior notice.

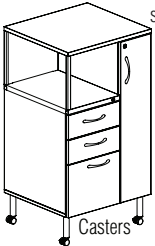
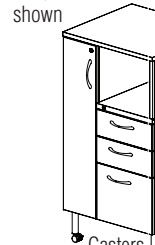
MODEL	W x D x H	MODEL NUMBER								Approx. Packaged Weight	Delivered Pricing	
		Basic Model	Pull Style	Base	Shell Color	Door/Drawer Front Color	Pull Color	Lock Option	Lock Color			
 <p>Arc pulls shown</p> <p>Right Facing Wardrobe - Left Facing Shelf/Box/Box/File Tower</p> <ul style="list-style-type: none"> Wardrobe and file lock independently Two 6" drawers; one 12" file drawer Open shelf large enough to hold binders Available with casters or glides Wardrobe includes hanger bar and boot tray Legs field installed 	24 x 22 x 46"	TSTW2439BBF9RW	<input type="checkbox"/>	<input type="checkbox"/>	<input type="checkbox"/>	<input type="checkbox"/>	<input type="checkbox"/>	<input type="checkbox"/>	<input type="checkbox"/>	141.0#	\$ 2077	
 <p>Arc pulls shown</p> <p>Left Facing Wardrobe - Right Facing Shelf/Box/Box/File Tower</p> <ul style="list-style-type: none"> Wardrobe and file lock independently Two 6" drawers; one 12" file drawer Open shelf large enough to hold binders Available with casters or glides Wardrobe includes hanger bar and boot tray Legs field installed 	24 x 22 x 46"	TSTW2439BBF9LW	<input type="checkbox"/>	<input type="checkbox"/>	<input type="checkbox"/>	<input type="checkbox"/>	<input type="checkbox"/>	<input type="checkbox"/>	<input type="checkbox"/>	141.0#	\$ 2077	
			A	B	C	D	E	F	G	H		

HOW TO ORDER

- Indicate the following information on order form:
- Quantity of each item.
 - Model number, including options. See "How To Build a Model Number".
 - Any special service required.

Note:

- The indicates that a choice is required.
- The absence of the indicates that no choice is required.
- Alpha-numeric characters in place of indicate that no other alternatives are available.

HOW TO BUILD A MODEL NUMBER

- A** Select basic model.
- B** Select pull style.
- ARCN** - Arc pull
- S6** - Beveled pull Black
- S5** - Beveled pull Satin Chrome
- STP** - Strap pull
- CZP** - Nickel Rectangle (Connection Zone) pull
- C** Select base option.
- 4CR** - 4 black casters (2 locking)
- 4GL** - 4 black glides
- D** Select shell color. Refer to the **Product Color Options** page in this price list.
- E** Select door/drawer color. Refer to the **Product Color Options** page in this price list.
- F** Select pull color.

- Select if Strap Pull (STP) is selected.
- SBL** - Black
- SSR** - Silver
- Refer to the **Product Color Options** page in this price list.
- G** Select lock option.
- KS** - Key standard - 2 locks
- NLC** - No lock core - 2 locks
- H** Select lock color.
- BLL** - Black
- SCL** - Satin Chrome
- Refer to the **Product Color Options** page in this price list.

SPECIAL SERVICES**Special Carton Marking**

With specially marked information N/C

Shipping

Ships assembled, FOB Pembroke, ON K8A 0E1, freight prepaid. Freight class 100.

Specifications and prices are subject to change without prior notice.

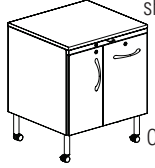
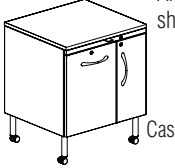

	W x D x H	MODEL NUMBER											Approx. Packaged Weight	Delivered Pricing	Laminate Grade 2 add to list price	Laminate Grade 3 add to list price	
		Basic Model	Pull Style	Base	Grommet/Cutout Option	Top Laminate Color	Edge Color	Shell Color	Door/Drawer Front Color	Pull Color	Lock Option	Lock Color					
 <p>Arc pulls shown Casters</p> <p>TSVA Left Facing Cupboard - Right Facing Drawer Vanity (Laminate Top)</p> <ul style="list-style-type: none"> • Flip-up laminate top with marker-board on underside • Felt lined inside top compartment • Larger drawer houses 1-1/2" hidden inner pencil drawer • 48" high when lid is raised • Cupboard with removable shelf • Bumpers included • Available with casters or glides • Legs field installed 	24 x 22 x 29"	TSVA2422VLLDR	<input type="checkbox"/>	<input type="checkbox"/>	<input type="checkbox"/>	<input type="checkbox"/>	<input type="checkbox"/>	<input type="checkbox"/>	<input type="checkbox"/>	<input type="checkbox"/>	<input type="checkbox"/>	<input type="checkbox"/>	132.0#	\$ 2263	\$ 19	\$ 120	
 <p>Arc pulls shown Casters</p> <p>TSVA Right Facing Cupboard - Left Facing Drawer Vanity (Laminate Top)</p> <ul style="list-style-type: none"> • Flip-up laminate top with marker-board on underside • Felt lined inside top compartment • Larger drawer houses 1-1/2" hidden inner pencil drawer • 48" high when lid is raised • Cupboard with removable shelf • Bumpers included • Available with casters or glides • Legs field installed 	24 x 22 x 29"	TSVA2422VLRDR	<input type="checkbox"/>	<input type="checkbox"/>	<input type="checkbox"/>	<input type="checkbox"/>	<input type="checkbox"/>	<input type="checkbox"/>	<input type="checkbox"/>	<input type="checkbox"/>	<input type="checkbox"/>	<input type="checkbox"/>	132.0#	\$ 2263	\$ 19	\$ 120	
			A	B	C	D	E	F	G	H	I	J	K				

HOW TO ORDER

Indicate the following information on order form:

- Quantity of each item.
- Model number, including options. See "How To Build a Model Number".
- Any special service required.

Note:

- The indicates that a choice is required.
- The absence of the indicates that no choice is required.
- Alpha-numeric characters in place of indicate that no other alternatives are available.

HOW TO BUILD A MODEL NUMBER

A Select basic model.

B Select pull style.

ARC - Arc pull
S6 - Beveled pull Black
S5 - Beveled pull Satin Chrome
STP - Strap pull
CZP - Nickel Rectangle (Connection Zone) pull

C Select base option.

4CR - 4 black casters (2 locking)
4GL - 4 black glides

D Select grommet.

NG - No grommet
G - Grommet

E Select top laminate color.
Refer to the **Product Color Options** page in this price list.

F Select edge color.

Refer to the **Product Color Options** page in this price list.

G Select shell color.
Refer to the **Product Color Options** page in this price list.

H Select door/drawer color.
Refer to the **Product Color Options** page in this price list.
Locking filler rail is painted the same color as the door and drawer fronts.

I Select pull color.

SBL - Black
SSR - Silver
Refer to the **Product Color Options** page in this price list.

J Select lock option.

KS - Key standard - 2 locks
NLC - No lock core - 2 locks

K Select lock color.

BLL - Black

SCL - Satin Chrome
Refer to the **Product Color Options** page in this price list.

SPECIAL SERVICES

Special Carton Marking
With specially marked information N/C

Shipping
Ships assembled, FOB Pembroke, ON K8A 0E1, freight prepaid. Freight class 100.

Specifications and prices are subject to change without prior notice.

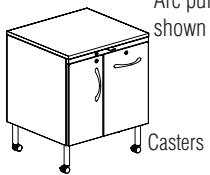
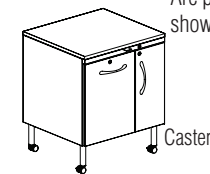

	W x D x H	MODEL NUMBER										Approx. Packaged Weight	Delivered Pricing	
		Basic Model	Pull Style	Base	Grommet Option	Shell Color	Door/Drawer Front Color	Top Paint Color	Pull Color	Lock Option	Lock Color			
 <p>Arc pulls shown</p> <p>Casters</p> <p>TSVA</p> <p>Left Facing Cupboard - Right Facing Drawer Vanity (Steel Top)</p> <ul style="list-style-type: none"> • Flip-up steel top with magnetic markerboard on underside • Felt lined inside top compartment • Larger drawer houses 1-1/2" hidden inner pencil drawer • 48" high when lid is raised • Cupboard with removable shelf • Bumpers included • Available with casters or glides • Legs field installed 	24 x 22 x 29"	TSVA2422VSLDR	<input type="checkbox"/>	<input type="checkbox"/>	<input type="checkbox"/>	<input type="checkbox"/>	<input type="checkbox"/>	<input type="checkbox"/>	<input type="checkbox"/>	<input type="checkbox"/>	<input type="checkbox"/>	132.0#	\$ 2126	
 <p>Arc pulls shown</p> <p>Casters</p> <p>TSVA</p> <p>Right Facing Cupboard - Left Facing Drawer Vanity (Steel Top)</p> <ul style="list-style-type: none"> • Flip-up steel top with magnetic markerboard on underside • Felt lined inside top compartment • Larger drawer houses 1-1/2" hidden inner pencil drawer • 48" high when lid is raised • Cupboard with removable shelf • Bumpers included • Available with casters or glides • Legs field installed 	24 x 22 x 29"	TSVA2422VSRDR	<input type="checkbox"/>	<input type="checkbox"/>	<input type="checkbox"/>	<input type="checkbox"/>	<input type="checkbox"/>	<input type="checkbox"/>	<input type="checkbox"/>	<input type="checkbox"/>	<input type="checkbox"/>	132.0#	\$ 2126	
			A	B	C	D	E	F	G	H	I	J		

HOW TO ORDER

- Indicate the following information on order form:
1. Quantity of each item.
 2. Model number, including options. See "How To Build a Model Number".
 3. Any special service required.

- Note:
- The indicates that a choice is required.
 - The absence of the indicates that no choice is required.
 - Alpha-numeric characters in place of indicate that no other alternatives are available.

HOW TO BUILD A MODEL NUMBER

- A** Select basic model.
- B** Select pull style.
- ARCN** - Arc pull
S6 - Beveled pull Black
S5 - Beveled pull Satin Chrome
STP - Strap pull
CZP - Nickel Rectangle (Connection Zone) pull
- C** Select base option.
- 4CR** - 4 black casters (2 locking)
4GL - 4 black glides
- D** Select grommet.
- NG** - No grommet
G - Grommet
- E** Select shell color.
 Refer to the **Product Color Options** page in this price list.
- F** Select door/drawer color.

Refer to the **Product Color Options** page in this price list.
 Locking filler rail is painted the same color as the door and drawer fronts.

- G** Select top paint color.
 Refer to the **Product Color Options** page in this price list.
- H** Select pull color.
- SBL** - Black
SSR - Silver
 Refer to the **Product Color Options** page in this price list.
- I** Select lock option.
- KS** - Key standard - 2 locks
NLC - No lock core - 2 locks
- J** Select lock color.
- BLL** - Black
SCL - Satin Chrome
 Refer to the **Product Color Options** page in this price list.

SPECIAL SERVICES
Special Carton Marking

With specially marked information N/C

Shipping

Ships assembled, FOB Pembroke, ON K8A 0E1, freight prepaid. Freight class 100.

Specifications and prices are subject to change without prior notice.

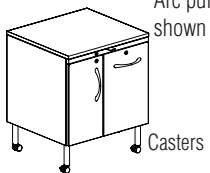
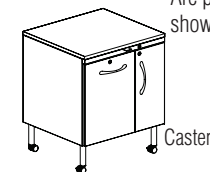

	W x D x H	MODEL NUMBER										Approx. Packaged Weight	Delivered Pricing
		Basic Model	Pull Style	Base	Grommet/Cutout Option	Shell Color	Door/Drawer Front Color	Top Paint Color	Pull Color	Lock Option	Lock Color		
 <p>Arc pulls shown</p> <p>Casters</p> <p>TSVA</p> <p>Left Facing Cupboard - Right Facing Drawer Vanity (Steel Top)</p> <ul style="list-style-type: none"> • Flip-up steel top with magnetic markerboard on underside • Felt lined inside top compartment • Larger drawer houses 1-1/2" hidden inner pencil drawer • 48" high when lid is raised • Cupboard with removable shelf • Bumpers included • Available with casters or glides • Legs field installed 	24 x 22 x 29"	TSVA2422VSLDR	<input type="checkbox"/>	<input type="checkbox"/>	<input type="checkbox"/>	<input type="checkbox"/>	<input type="checkbox"/>	<input type="checkbox"/>	<input type="checkbox"/>	<input type="checkbox"/>	<input type="checkbox"/>	132.00#	\$ 2126
 <p>Arc pulls shown</p> <p>Casters</p> <p>TSVA</p> <p>Right Facing Cupboard - Left Facing Drawer Vanity (Steel Top)</p> <ul style="list-style-type: none"> • Flip-up steel top with magnetic markerboard on underside • Felt lined inside top compartment • Larger drawer houses 1-1/2" hidden inner pencil drawer • 48" high when lid is raised • Cupboard with removable shelf • Bumpers included • Available with casters or glides • Legs field installed 	24 x 22 x 29"	TSVA2422VSRDR	<input type="checkbox"/>	<input type="checkbox"/>	<input type="checkbox"/>	<input type="checkbox"/>	<input type="checkbox"/>	<input type="checkbox"/>	<input type="checkbox"/>	<input type="checkbox"/>	<input type="checkbox"/>	132.00#	\$ 2126

A B C D E F G H I J

HOW TO ORDER

- Indicate the following information on order form:
1. Quantity of each item.
 2. Model number, including options. See "How To Build a Model Number".
 3. Any special service required.

Note:

- The indicates that a choice is required.
- The absence of the indicates that no choice is required.
- Alpha-numeric characters in place of indicate that no other alternatives are available.

HOW TO BUILD A MODEL NUMBER

- A** Select basic model.
 - ARCN - Arc pull
 - S6 - Beveled pull Black
 - S5 - Beveled pull Satin Chrome
 - STP - Strap pull
 - CZP - Nickel Rectangle (Connection Zone) pull
- B** Select pull style.
 - 4CR - 4 black casters (2 locking)
 - 4GL - 4 black glides
- C** Select base option.
 - NG - No grommet
 - G - Grommet
- D** Select grommet.
 - NG - No grommet
 - G - Grommet
- E** Select shell color. Refer to the **Product Color Options** page in this price list.
- F** Select door/drawer color.

- G** Select top paint color. Refer to the **Product Color Options** page in this price list.
- H** Select pull color. Refer to the **Product Color Options** page in this price list.
 - SBL - Black
 - SSR - Silver
- I** Select lock option. Refer to the **Product Color Options** page in this price list.
 - KS - Key standard - 2 locks
 - NLC - No lock core - 2 locks
- J** Select lock color. Refer to the **Product Color Options** page in this price list.
 - BLL - Black
 - SCL - Satin Chrome

SPECIAL SERVICES

Special Carton Marking

With specially marked information N/C

Shipping

Ships assembled, FOB Pembroke, ON K8A 0E1, freight prepaid. Freight class 100.

Specifications and prices are subject to change without prior notice.



W x D x H	MODEL NUMBER										Approx. Packaged Weight	Delivered Pricing	Laminate Grade 2 add to list price	Laminate Grade 3 add to list price	
	Basic Model	Pull Style	Base	Top Laminate Color	Edge Color	Shell Color	Door/Drawer Front Color	Pull Color	Lock Option	Lock Color					
36 x 18 x 21-3/4"	TSCB3615LCS	<input type="checkbox"/>	<input type="checkbox"/>				<input type="checkbox"/>	<input type="checkbox"/>	<input type="checkbox"/>	<input type="checkbox"/>	<input type="checkbox"/>	56.00#	\$ 1042	N/A	N/A
36 x 18 x 27"	TSCB3615LCW	<input type="checkbox"/>	<input type="checkbox"/>	<input type="checkbox"/>	<input type="checkbox"/>	<input type="checkbox"/>	<input type="checkbox"/>	<input type="checkbox"/>	<input type="checkbox"/>	<input type="checkbox"/>	<input type="checkbox"/>	70.00#	\$ 1358	\$ 19	\$ 120

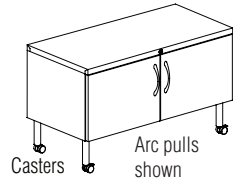

TSCB
Low Cupboard

- All steel construction
- 2 open doors for large storage cavity
- Optional pad specified separately
- Available with casters or glides
- Legs field installed

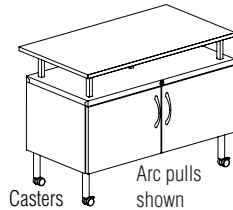

TSCB
Low Cupboard with Raised Laminate Worktop

- All steel construction
- 2 open doors for large storage cavity
- 27" high 3/4" laminate raised worktop
- Available with casters or glides
- Legs and worktop field installed

A B C D E F G H I J

HOW TO ORDER

- Indicate the following information on order form:
1. Quantity of each item.
 2. Model number, including options. See "How To Build a Model Number".
 3. Any special service required.

Note:

- The indicates that a choice is required.
- The absence of the indicates that no choice is required.
- Alpha-numeric characters in place of indicate that no other alternatives are available.

HOW TO BUILD A MODEL NUMBER

- A** Select basic model.
- B** Select pull style.
 - ARCN** - Arc pull
 - S6** - Beveled pull Black
 - S5** - Beveled pull Satin Chrome
 - STP** - Strap pull
 - CZP** - Nickel Rectangle (Connection Zone) pull
- C** Select base option.
 - 4CR** - 4 black casters (2 locking)
 - 4GL** - 4 black glides
- D** Select top laminate color. Refer to the **Product Color Options** page in this price list.
- E** Select edge color. Refer to the **Product Color Options** page in this price list.
- F** Select shell color.

- Refer to the **Product Color Options** page in this price list.
- G** Select door/drawer color. Refer to the **Product Color Options** page in this price list.
- H** Select pull color. Select if Strap Pull (STP) is selected.
 - SBL** - Black
 - SSR** - Silver
 Refer to the **Product Color Options** page in this price list.
- I** Select lock option.
 - KS** - Key standard - 1 lock
 - NLC** - No lock core - 1 lock
- J** Select lock color.
 - BLL** - Black
 - SCL** - Satin Chrome
 Refer to the **Product Color Options** page in this price list.

SPECIAL SERVICES

Special Carton Marking

With specially marked information N/C

Shipping

Ships assembled, FOB Pembroke, ON K8A 0E1, freight prepaid. Freight class 100.

Specifications and prices are subject to change without prior notice.



W x D x H	MODEL NUMBER												Approx. Packaged Weight	Delivered Pricing	Delivered Pricing Fabric Grade 1 & C.O.M.	Delivered Pricing Fabric Grade 2	Delivered Pricing Fabric Grade 3	Delivered Pricing Vinyl Group 2V	Delivered Pricing Pallas Fabric Group P0	Delivered Pricing Pallas Fabric Group P1	Delivered Pricing Pallas Fabric Group P2	Delivered Pricing Pallas Fabric Group P3	Delivered Pricing Pallas Fabric Group P4	Laminate Grade 2 add to list price	Laminate Grade 3 add to list price	
	Basic Model	Pull Style	Base	Top Laminate Color	Edge Color	Shell Color	Door Color	Pull Color	Lock Option	Lock Color	Screen Felt Color	Uph. Color														
36 x 21 x 27 - 44-1/2"	TSCB3615LCWS	<input type="checkbox"/>	<input type="checkbox"/>	<input type="checkbox"/>	<input type="checkbox"/>	<input type="checkbox"/>	<input type="checkbox"/>	<input type="checkbox"/>	<input type="checkbox"/>	<input type="checkbox"/>	<input type="checkbox"/>	<input type="checkbox"/>		80.00#	\$ 1989									\$ 19	\$ 120	
36 x 18 x 1-1/4"	TSP3618											<input type="checkbox"/>		0.00#	N/A	\$ 168	\$ 190	\$ 192	\$ 192	\$ 194	\$ 209	\$ 228	\$ 229	\$ 247	N/A	N/A

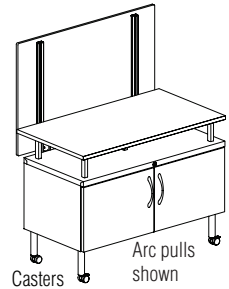

TSCB

Low Cupboard with Raised Laminate Worktop and Adjustable Screen

- All steel construction
- 2 open doors for large storage cavity
- 27" high 3/4" laminate raised worktop
- Adjustable screen attaches to worktop
- Available with casters or glides
- Legs, worktop, adjustable screen field installed

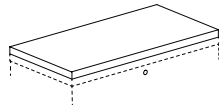

TSP3618

Low Cupboard Pad

- Constructed of 3/4" thick foam and medium density fiberboard for a total thickness of 1-1/4"
- Non-slip pads on underside
- Fabric runs side-to-side
- COM = .75 yd

A B C D E F G H I J K L

HOW TO ORDER

- Indicate the following information on order form:
- Quantity of each item.
 - Model number, including options. See "How To Build a Model Number".
 - Any special service required.

Note: • The indicates that a choice is required.
• The absence of the indicates that no choice is required.
• Alpha-numeric characters in place of indicate that no other alternatives are available.

HOW TO BUILD A MODEL NUMBER

- A** Select basic model.
- B** Select pull style.
ARC - Arc pull
S6 - Beveled pull Black
S5 - Beveled pull Satin Chrome
STP - Strap pull
CZP - Nickel Rectangle (Connection Zone) pull
- C** Select base option.
4CR - 4 black casters (2 locking)
4GL - 4 black glides
- D** Select top laminate color. Refer to the **Product Color Options** page in this price list.
- E** Select edge color. Refer to the **Product Color Options** page in this price list.
- F** Select shell color.

- Refer to the **Product Color Options** page in this price list.
- G** Select door/drawer color. Refer to the **Product Color Options** page in this price list.
- H** Select pull color. Select if Strap Pull (STP) is selected.
SBL - Black
SSR - Silver
 Refer to the **Product Color Options** page in this price list.
- I** Select lock option.
KS - Key standard - 1 lock
NLC - No lock core - 1 lock
- J** Select lock color.
BLL - Black
SCL - Satin Chrome
 Refer to the **Product Color Options** page in this price list.
- K** Select screen polyester felt color.

- Refer to the **Product Color Options** page in this price list.
- L** Select upholstery color. Refer to ki.com/fabrics

SPECIAL SERVICES

Special Carton Marking

With specially marked information N/C

Shipping

Ships assembled, FOB Pembroke, ON K8A 0E1, freight prepaid or High Point, NC 27263. Freight class 100.

Specifications and prices are subject to change without prior notice.



	MODEL	Features	MODEL NUMBER		Approx. Packaged Weight	Delivered Pricing
			Basic Model			
TTA06	Storage Bumper • Self-adhesive • Protects storage unit from damaging screens or walls • Clear in color • 18mm diameter • 10mm height • Quantity 1 bumper		2.KP57431		0.00#	\$ 1
AC905	P-Series Keys • Double bit design • Range of 200 different core/key numbers available • Must specify lock number(s) requested when ordering cut key or lock core/key sets	Lock Core/2 Key Set - Black	2.KP20522		0.40#	\$ 16
		Lock Core/2 Key Set - Satin Chrome	2.KP20522.SC		0.40#	16
		Master Key	2.KP20550		0.20#	12
		Extractor Key	2.KP20551		0.20#	12
		Blank Key	2.KP20552		0.20#	3
	Cut Key	2.KP20557		0.20#	4	

A

HOW TO ORDER

- Indicate the following information on order form:
- Quantity of each item.
 - Model number, including options. See "How To Build a Model Number".
 - Any special service required.

- Note:
- The indicates that a choice is required.
 - The absence of the indicates that no choice is required.
 - Alpha-numeric characters in place of indicate that no other alternatives are available.

HOW TO BUILD A MODEL NUMBER

- A** Select basic model.

SPECIAL SERVICES

Special Carton Marking

With specially marked information N/C

Shipping

Ships assembled, FOB Pembroke, ON K8A 0E1, freight prepaid. Freight class 100.

Specifications and prices are subject to change without prior notice.



	MODEL	W x D	MODEL NUMBER		Approx. Packaged Weight	Delivered Pricing
			Basic Model			
TTA06	Pedestal Pencil Drawer Liner <ul style="list-style-type: none"> Felt liner for pedestal hidden inner pencil drawer Prevents shifting of items in drawer Grey in color 	9" x 15-3/4"	2.KP57032.P		0.00#	\$ 42
TTA06	Vanity Pencil Drawer Liner <ul style="list-style-type: none"> Felt liner for vanity hidden inner pencil drawer Prevents shifting of items in drawer Grey in color; matches felt inside top compartment of vanity 	12" x 13-3/4"	2.KP57032.V		0.00#	\$ 42
TTA06	Tower Hanging Folder Bar <ul style="list-style-type: none"> For filing letter or legal size paper side-to-side in file drawer 1 bar needed for filing Quantity 1 bar 		2.KP40268.12		0.00#	\$ 12
TTA06	Chest Hanging Folder Bar <ul style="list-style-type: none"> For filing letter or legal size paper front-to-back in file drawer 2 bars needed for filing; need to purchase 2 per unit to increase filing capacity Quantity 1 bar 		2.KP40268.15		0.00#	\$ 12

A

HOW TO ORDER

- Indicate the following information on order form:
- Quantity of each item.
 - Model number, including options. See "How To Build a Model Number".
 - Any special service required.

- Note:
- The indicates that a choice is required.
 - The absence of the indicates that no choice is required.
 - Alpha-numeric characters in place of indicate that no other alternatives are available.

HOW TO BUILD A MODEL NUMBER

- A** Select basic model.

SPECIAL SERVICES

Special Carton Marking

With specially marked information N/C

Shipping

Ships assembled, FOB Pembroke, ON K8A 0E1, freight prepaid. Freight class 100.

Specifications and prices are subject to change without prior notice.



Slim Corner



Slim Seat with Power



Slim Seat with Table



Ottoman



Table

General Dimensions			
Seat width	16"	44"	33"
Seat depth	16"	16"	16"
Seat height	18"	18"	18"
Overall Dimensions			
Width	22"	44"	44"
Depth	22"	22"	22"
Height	29"	29"	29"

Overall Dimensions		
Width	22"	22"
Depth	22"	22"
Height	18"	18"

INFORMATION

Warranty
Refer to KI Terms & Conditions document or visit ki.com

TECHNICAL SPECIFICATIONS

Seat/Backrest & Table Frames

All seat/backrest and table frames are constructed of $\frac{3}{4}$ " CNC machined, laminated hardwood plywood. Main frame joints are nailed and glued in addition to interlocking joinery across all stress points. Frames have $\frac{1}{4}$ " thick, 2.5 density 45 lb compression "soft feel" foam covering all exposed frame areas under the upholstery.

Seat & Backrest Foam

Seat and backrest foam is 2.5 density 45 lb compression, with $2\frac{1}{2}$ " thickness on seat surface and $1\frac{1}{2}$ " thick at the backrest front. Both seat and backrest have an additional $\frac{1}{2}$ " layer of 2.6 density, 80 lb compression "topper" foam for tight seat and back upholstery fit. Other exposed surfaces have $\frac{1}{4}$ " thick, 2.5 density 45 lb compression "soft feel" foam under the upholstery.

Base Leg Options

Leg assemblies are specified differently for glides or casters. Legs are constructed of $1\frac{1}{4}$ " O.D. by 16-gauge round steel tubing, welded to a 7-gauge steel spider plate at one end and are fitted with $\frac{5}{16}$ -18 threaded inserts at the opposite end to accept glides or casters. Overall distance from floor to bottom of seat is 7" for both caster and glide. Length of leg varies to accommodate either caster or glide. Leg assemblies are powder-coat painted in select KI colors and attach to the base structure using $\frac{1}{4}$ -20 x 1" flat head screws.

Glides

Adjustable glides have $1\frac{1}{4}$ " diameter feet in black nylon with $\frac{5}{16}$ -18 threaded steel stems which twist in and secure to steel legs. Allows for $\frac{3}{4}$ " of adjustability.

Casters

Fully swiveling and locking casters have $1\frac{1}{2}$ " diameter dual-wheels, constructed with soft, non-marring rubber, and are individually rated at 85 lb static loading. Caster stems are $\frac{5}{16}$ -18 and thread into optional caster legs. Casters are 2" tall overall when installed and four caster assemblies are used per seat or table unit.

Tabletop

Table top structure is machined from 45 lb medium density fiberboard core material. The top is finished with .025" to .030" thick high-pressure plastic laminate on five sides, glued in place. Two opposite edges are "waterfall" profile with $\frac{5}{8}$ " radius post formed laminate, and two edges are "self-edge" laminate profile. The overall thickness of the finished table top structure is $3\frac{3}{4}$ " and it is secured to the upholstered frame structure below.

Optional AC Power & USB Charger

The optional USB/AC power module houses one 15-amp, 125 volt AC simplex receptacle with one 2.1-amp, 5 volt DC USB Type A and one Type C port (2.0 and 3.0 compatible, no data). Power module provides device charging and direct AC power. The module's aluminum housing contains the power & USB circuitry. The 72" exposed power cord is 14 AWG, 15-amp NEMA rated, three-conductor SJT, with a three-prong grounded plug. The 3-prong plug is oriented straight off the power cord. The power cord is strain-relief mounted to the rear of the module's aluminum housing and as it exits the lounge.

The entire electrical power and USB module is UL listed and passes UL spill test rating for protection against liquids. Both USB ports can power and charge two separate mobile devices simultaneously. The power module's optional faceplate/power & USB color combinations are: black/black, white/white and silver/white. Faceplates are finished with powder-coat paint.

Compliance

Tattoo Seating is designed and manufactured to meet or exceed required ANSI/BIFMA x5.4-2012. Glides meet KI's internal 400 lb weight rating standard on TLS800, TLT800, TLT3800 and TLE800 models. Casters meet KI's internal 300 lb weight rating standard on TLS600, TLT600, TL3600 and TLE600.

Tattoo Slim Seat w/ Left Facing table

Unique design is space saving to maximize a limited footprint. Created for user control of elements relating to placement, purpose, accessibility and power.

Laminate tables are available in the slim seat, or as larger stand alone products.

Overall depth on all seating products is 22" allowing for modular configurations and ease of rearrangement.

Optional power on all seating products available (except ottoman) accepts USB and 120V.

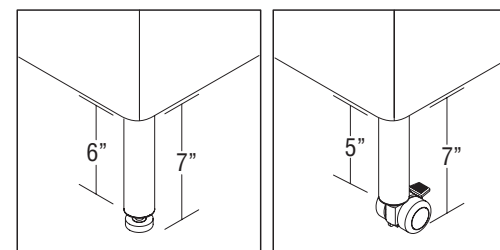
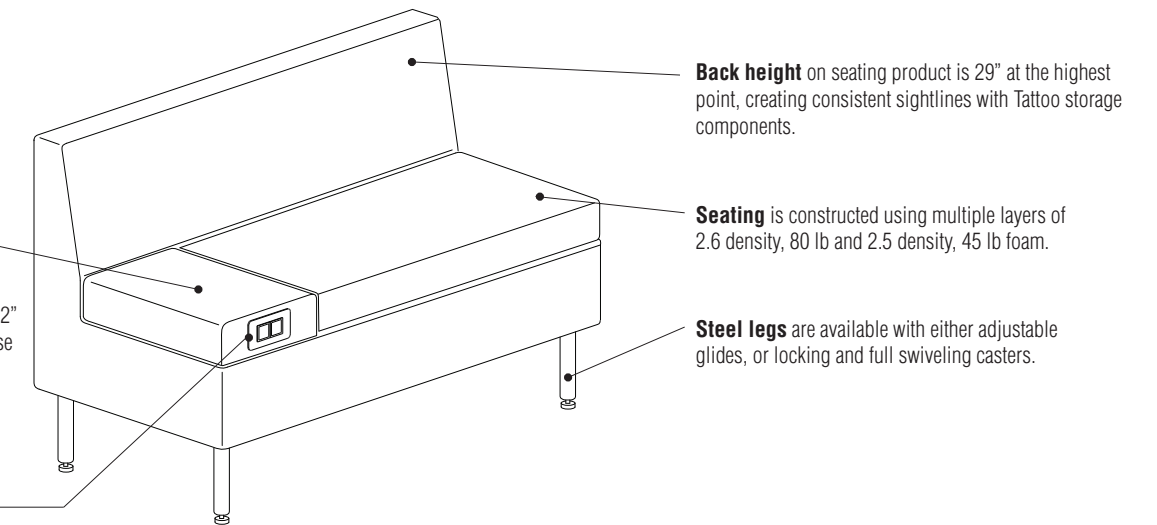

Glide Leg Option

Caster Leg Option

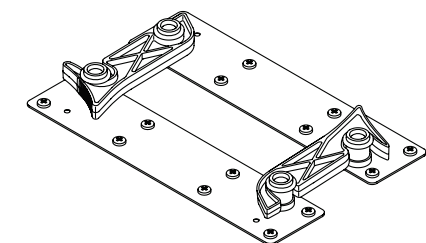

Ganger Assembly



DIMENSIONS

Overall Dimension							
Model	A (width)	B (depth)	C (seat width)	D (seat depth)	E (overall height)	F (seat height)	G (leg length)
Ottoman (TL3)	22"	22"	22"	22"	18"	18"	7"
Table (TLE)	22"	22"			18"		7"
Slim Seat (TLS)	44"	22"	44"	16"	29"	18"	7"
Slim Seat with Integrated Table (TLSQ/TLSR)	44"	22"	33"	16"	29"	18"	7"
Slim Corner (TLT)	22"	22"	16"	16"	29"	18"	7"

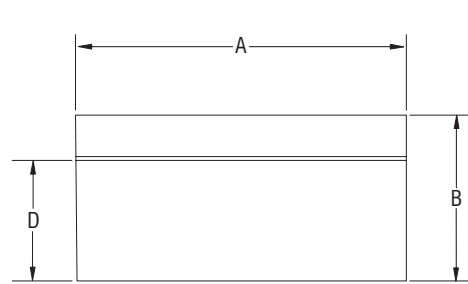

TLS
Slim Seat (top view)

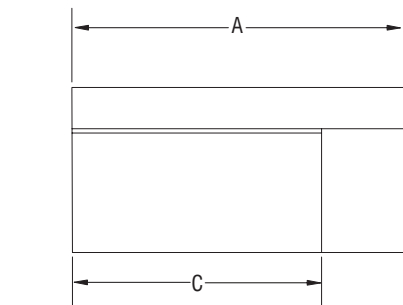

TLSQ/TLSR
Slim Seat with Integrated Table (top view)

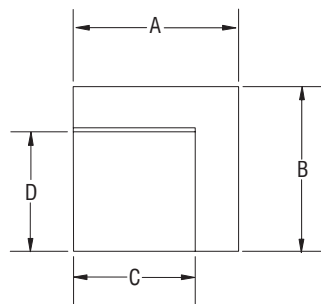

TLT
Slim Corner (top view)

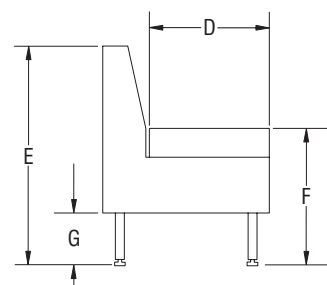

TLS/TLT
Slim Seat/Slim Corner (sideview)

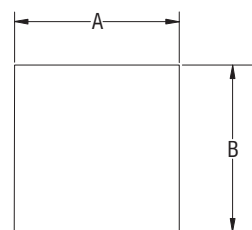

TL3
Ottoman (top view)

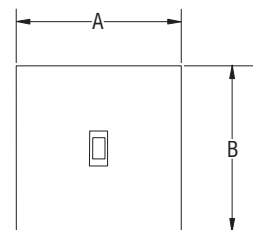

TLE
Table (top view)

STATEMENT OF LINE

Slim Seat

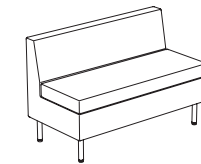

TLS800
no power
with glides

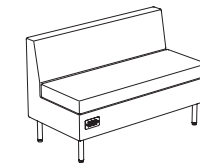

TLS800
left facing optional power
with glides

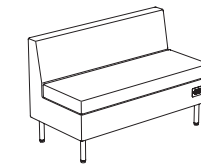

TLS800
right facing optional power
with glides

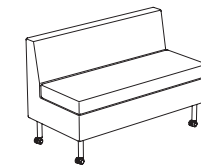

TLS600
no power
with casters

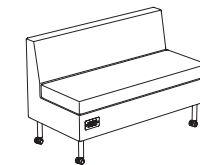

TLS600
left facing optional power
with casters

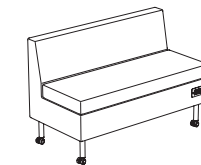

TLS600
right facing optional power
with casters

Slim Seat with Integrated Table

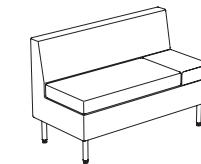

TLS80R
no power
with glides

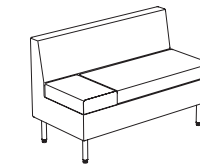

TLS80Q
no power
with glides

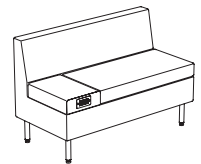

TLS80Q
left facing optional power
with glides

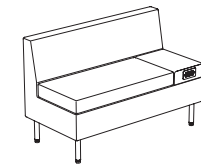

TLS80R
right facing optional power
with glides

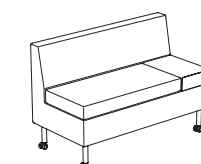

TLS60R
no power
with casters

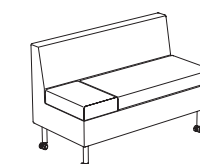

TLS60Q
no power
with caster

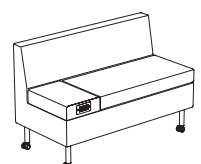

TLS60Q
left facing optional power
with casters

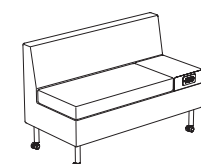

TLS60R
right facing optional power
with casters

Slim Corner

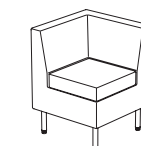

TLT8
no power
with glides

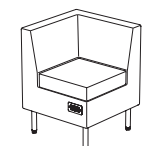

TLT803
left facing
optional power
with glides

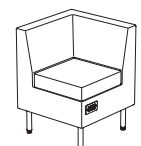

TLT804
right facing
optional power
with glides

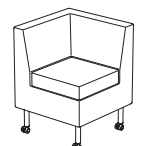

TLT6
no power
with casters

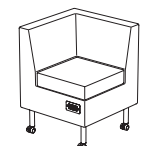

TLT603
left facing
optional power
with casters

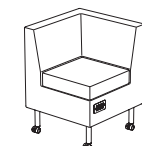

TLT604
right facing
optional power
with casters

Ottoman

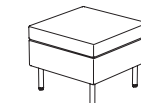

TL3800
with glides

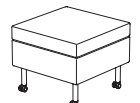

TL3600
with casters

Table

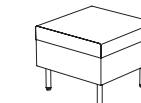

TLE800
no power
with glides

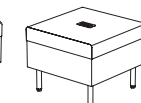

TLE800
optional power
with glides

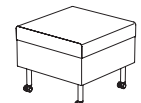

TLE600
no power
with casters



TLE600
power
with casters

Customer's Own Material ■

Specifications Form January 2023

How to Specify

As a standard procedure, KI applies seating upholstery as swatched by the textile distributor. Reference distributor's website. Upholstery that is required to be applied differently than is swatched, will need a Product Modification Request written specifying the direction the upholstery is to be applied.

Seating upholstery requiring specific positioning of intricate patterns or patterns repeats on seats and backrests, will need a Product Modification Request written including a sketch noting the specific requirements, as in Diagram A.

C.O.M. must be supplied in continuous yardage.

Yardage requirements listed in price list are based on plain goods 54" wide. Fabrics less than 54" wide, or those requiring matching (stripes, plaids, prints, large patterns) will require additional yardage based on the fabric used and the item ordered. Consult matrix below for additional yardage needed.

C.O.M. INCREASE MATRIX (yardage matrix is also applicable to any reservations of KI Ingrade, Pallas, or K.O.M. upholsteries).

This table is a general guide.

FABRIC WIDTH	PLAIN FABRIC	UNDER 7"	8"-13"	14"-21"	22"-27"	28"-33"	34"-40"	41"-48"
	FABRIC	REPEAT	REPEAT	REPEAT	REPEAT	REPEAT	REPEAT	REPEAT
54"	0	20%	25%	30%	45%	55%	70%	80%
51"-53"	15%	25%	30%	35%	50%	60%	80%	90%
48"-50"	20%	30%	35%	40%	55%	65%	85%	95%
45"-47"	30%	45%	50%	55%	60%	80%	90%	100%
36"-44"	50%	65%	70%	75%	80%	100%	110%	120%

Fabric with double repeat: If using a fabric with a double repeat, please follow this formula: take the total amount of the larger and half of the smaller repeat; add together to find the correct overall repeat. Example: 10" vertical with 14" horizontal would be $14+5=19$.

If fabric comes in on multiple rolls, one additional yard per roll needs to be added to the yardage requirement.

Leather hides must be a minimum of 50 square feet of usable material. The outer edges cannot be calculated as square feet or yardage. To determine square footage, multiply unit yardage by 18 square feet to obtain the total square footage required per unit.

For exact production yardage requirements, call 1-800-424-2432, ext. 2707.

Production

Customer's upholstery must be approved prior to acceptance for production.

After approval, a memo swatch of the C.O.M. from the textile distributor must accompany the order. KI assumes no responsibility for wear, defects, or performance of C.O.M. or K.O.M. upholstery.

C.O.M. not received into the appropriate facility 3 weeks prior to acknowledged delivery date may go on hold. See KI C.O.M. Shipping Location listing for the correct facility address by product.

All C.O.M. must be labeled as follows:

1. Name and address
2. Your purchase order number
3. Our style number to which fabric is to be applied
4. Supplier name and fabric name, number, and color

ALL C.O.M. Shipments must be prepaid. Collect shipments will be refused.

Testing

When KI requires testing, actual yardage to upholster one chair may be required. The C.O.M. Specialist will confirm model and fabric testing requirements when applicable.

Approved test samples will be applied to the order or will be held for 6 months. After 6 months, the sample will no longer be applied to your order. For all product testing, send fabric samples to the manufacturing facility. See KI C.O.M. Shipping Location listing for the correct facility address by product.

ALL C.O.M. Shipments must be prepaid. Collect shipments will be refused.

Treated Materials

If C.O.M. requires processing such as a stain resistance treatment or acrylic backing, it may shrink. To prevent delays in delivery or back ordering due to shrinkage, please have your processor verify measurement after processing and assure adequate yardage shipped.

Split Orders

If a portion of the shipment which does not require C.O.M. application is to be processed and shipped early, KI will enter the order immediately at your request. These split shipments are subject to minimum order changes.

Excess Upholstery Material

KI will dispose of excess upholstery material at the time of shipment unless expressly requested to return it with the product shipment.

Cancelled or Changed Orders

KI assumes no responsibility for extra C.O.M. due to a change of upholstery or cancellation of an order. If it the customer's responsibility to arrange for return of the material.

Contact the C.O.M. Specialist at 1-800-424-2432, ext. 2707, with questions or to request a split order

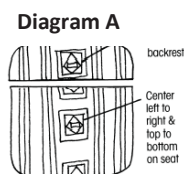



C.O.M. SHIPPING LOCATION



Architectural Walls	Panel Systems	Impress Ultra OM
Evoke..... MN	All Terrain.....KP	Intellect Wave GB
Genius..... MN	Balance MN	Jessa HN
Casegoods	Universal MN	JubileeVQ
Aristotle.....MN	Wireworks MN	Katera GB
Likha.....MN	Unite..... MN	Kurv Benches HN
Classroom Furniture	Residence Hall Furniture	Learn2GB
Cogni GB	RoomScape MN	LimeLite GB
Intellect Wave GB	Screens	Lyra HN
Learn2.....GB	All Terrain.....KP	Medical & Laboratory Stools OM
Ruckus..... GB	Connection Zone.....BW	MyPlace HN
Desking	Tributaire.....BW	MyWay HN
700 Series KP	True/Volition KP	Oath GB
Balance MN	Genesis..... KP	Opt4 GB
Genesis MN	Tattoo..... MN	Pilot OM
True KP	Universal..... BW	Promenade BW
Universal MN	Seating	Ruckus GB
WorkZone MN	600 Series..... BW	Sela HN
Files & Storage	Affina HN	Sift GB
700 Series..... GB	Altus GB	Signia OM
Connection.....BW	Apply GB	Soltice Metal HN
U-Series GB	Calida HN	Soltice HN
Tattoo.....BW	Cascha VT	Sonrisa HN
Fixed Seating	Civara VT	Strive GB
Concerto.....BW	Clamber HN	Sway BW
Single Pedestal GB	Cogni GB	Tattoo HN
Jury Base GB	Diem OM	Torsion-on-the-Go! GB
Lancaster.....BW	Doni GB	Torsion Air GB
Sequence GB	Gladly VQ	Zeker HN
University GB	Grazie GB	Zentori VT
	Hub HN	Zoetry HN
	Impress OM	

KI C.O.M. Manufacturing Site Addresses:

<u>BW</u> KI Bonduel Attn: COM Storage 204 West South St. Bonduel, WI 54107	<u>HN</u> KI High Point Attn: COM Storage 217 Feld Avenue High Point, NC 27263	<u>MN</u> KI Manitowoc Attn: COM Storage 1400 S. 41st St. Manitowoc, WI 54220	<u>VQ</u> KI Attn: COM Fabrics 6892 Marlin Circle La Palma, CA 90623
<u>GB</u> KI Green Bay Attn: COM Storage 1687 Westminster Drive - Gate 3 Green Bay, WI 54302	<u>KP</u> KI Pembroke Attn: COM Storage 1000 Olympic Dr. Pembroke, Ontario K8A6X7	<u>OM</u> KI Attn: COM Storage 1110 S. Mildred Ave. Ontario, CA 91761	<u>VT</u> KI Attn: COM Storage 2803 South Taylor Drive Sheboygan, WI 53081

Base Finish Color

Black
Blue Grey
Bronze Metallic
Cayenne
Champagne Metallic
Cool Grey
Cottonwood
Earthen Clay
Espresso Metallic
Everglade Shade
Flannel
Glitz Metallic
Hazy Jade
Honey Bee
Light Tone
Mardi Gras
Misty Brown
Nemo
Nordic
Poppy Red
Purple Haze
Rainforest
Raw Jasper
Rubber Ducky
Sand
Sky Blue
Starlight Silver Metallic
Surf's Up
Tarragon
Twilight Shadow
Ultra Blue
Warm Grey
Zesty Lime

Power Module Color

Black/Black power module
Silver/White power module
White/white power module

Table Top Surface Finish--Grade 1 Standard Laminate

BL	Beigewood
GR	Belair
ZM	Biltmore Cherry
CY	Black
CM	Brighton Walnut
CG	Castle Oak
CO	Cherry Storm
EY	Classic Linen
EX	Cocobala
EV	Crisp Linen
FN	Designer White
GZ	Dove Grey
HJ	Florence Walnut
HY	Friston Ash
LG	Frosty White
MG	Graphite Nebula
MY	Grey
NE	High Rise
ND	Hollyberry
PR	Island
PH	Italian Silver Ash
RQ	Kensington Maple
RJ	Lapis Blue
RK	Monticello Maple
SA	North Sea
SK	Ocean
SX	Pinnacle Walnut
SP	River Cherry
TQ	Shadow Zephyr
TI	Sterling Ash
UB	Titanium Evolv
WG	White Nebula
ZL	White Sand
	Windsor Mahogany

Table Top Surface Finish--Grade 2 Standard Laminate

WPBL	Akira
WPSL	Black Alicante
WPWH	Black Hills Oak
	Calcutta Marble
	Dering Forest
	Fawn Cypress
	Ice Mist
	Markerboard White
	Valley Forge Elm
	White River Forest

Table Top Surface Finish--Grade 3 Standard Laminate

LBZ	Black Velvet
LBQ	Cumberland Walnut
LBT	Designer White Velvet
LBK	Hartley Walnut
LBW	Nile Velvet
LCO	Raleigh Walnut
LX	Solano Walnut
LXI	Spruce Velvet
LCC	
LRI	
LDR	
LDG	
LFC	
LFH	
LFW	
LGN	
LGE	
LHE	
LHY	
LID	
LIT	
LKM	
LLB	
LMT	
LNA	
LON	
LPW	
LRV	
LSR	
LAZ	
LTV	
LWL	
LWN	
LWY	

Finish Cards

View color swatches for items listed within this document.

[Paints](#)
[Plastics/Poly](#)
[Wood/Veneer](#)
[Laminates](#)
[Molded Edges](#)
[Edge Styles](#)
[Hard Plastics](#)
[Glass](#)

Certain options referenced may not be available on GSA Schedule.

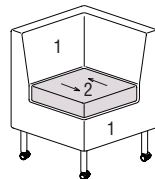
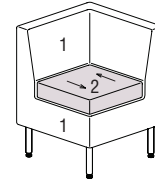

MODEL	Features	MODEL NUMBER							Approx. Packaged Weight	Delivered Pricing	Moisture Barrier add to list price	
		Basic Model	Power Option	Power Module Color	Moist. Barrier	Base Finish	Non-Contrast or Fabric Contrast 1	Fabric Contrast 2				
 TL6 Slim Corner, Left Facing Four-leg on Casters • Non-contrast C.O.M = 2.5 yd • 1 = Base and Back - C.O.M. = 2.5 yd • 2 = Seat - C.O.M. = .75 yd Overall Dimensions: W=22" D=22" H=29" Seat Dimensions: W=16" D=16" H=18" • Ganging (specify kit separately)	Non-contrast	TLT603/NC	<input type="checkbox"/>	<input type="checkbox"/> <input type="checkbox"/> <input type="checkbox"/> <input type="checkbox"/>	<input type="checkbox"/> <input type="checkbox"/> <input type="checkbox"/>	<input type="checkbox"/> <input type="checkbox"/>	<input type="checkbox"/> <input type="checkbox"/> <input type="checkbox"/>	<input type="checkbox"/> <input type="checkbox"/>	50.00#	\$ 1807	\$ 390	
	Contrast	TLT603/FC	<input type="checkbox"/>	<input type="checkbox"/> <input type="checkbox"/> <input type="checkbox"/> <input type="checkbox"/>	<input type="checkbox"/> <input type="checkbox"/> <input type="checkbox"/>	<input type="checkbox"/> <input type="checkbox"/>	<input type="checkbox"/> <input type="checkbox"/> <input type="checkbox"/>	<input type="checkbox"/> <input type="checkbox"/>	50.00#	1807	390	
 TL8 Slim Corner, Left Facing Four-leg on Glides • Non-contrast C.O.M = 2.5 yd • 1 = Base and Back - C.O.M. = 2.5 yd • 2 = Seat - C.O.M. = .75 yd Overall Dimensions: W=22" D=22" H=29" Seat Dimensions: W=16" D=16" H=18" • Ganging (specify kit separately)	Non-contrast	TLT803/NC	<input type="checkbox"/>	<input type="checkbox"/> <input type="checkbox"/> <input type="checkbox"/> <input type="checkbox"/>	<input type="checkbox"/> <input type="checkbox"/> <input type="checkbox"/>	<input type="checkbox"/> <input type="checkbox"/>	<input type="checkbox"/> <input type="checkbox"/> <input type="checkbox"/>	<input type="checkbox"/> <input type="checkbox"/>	50.00#	\$ 1807	\$ 390	
	Contrast	TLT803/FC	<input type="checkbox"/>	<input type="checkbox"/> <input type="checkbox"/> <input type="checkbox"/> <input type="checkbox"/>	<input type="checkbox"/> <input type="checkbox"/> <input type="checkbox"/>	<input type="checkbox"/> <input type="checkbox"/>	<input type="checkbox"/> <input type="checkbox"/> <input type="checkbox"/>	<input type="checkbox"/> <input type="checkbox"/>	50.00#	1807	390	
			A	B	C	D	E	F	G			

HOW TO ORDER

- Indicate the following information on order form:
- Quantity of each item.
 - Model number, including options. See "How To Build a Model Number".
 - Any special service required.

Note: • The indicates that a choice is required.
 • The absence of the indicates that no choice is required.
 • Alpha-numeric characters in place of indicate that no other alternatives are available.

HOW TO BUILD A MODEL NUMBER

- A** Select basic model.
- B** Select power option.
 NP - No power
 WP - With power; add \$333
- C** Select power module color.
 WPBL - Black/Black power module
 WPSL - Silver/White power module
 WPWH - White/white power module
- D** Select moisture barrier.
 MB - Moisture barrier
 NMB - No moisture barrier
 See pricing column for moisture barrier upcharge.
- E** Select base finish color.
 Refer to the **Product Color Options** page in this price list.
- F** Select non-contrast or fabric contrast 1.
 Refer to ki.com/fabrics.

- For yardage pricing, see Fabric Yardage Pricing page
- G** Select fabric contrast 2.
 Refer to ki.com/fabrics
- For yardage pricing, see Fabric Yardage Pricing page

FINISH INFORMATION

ADDITIONAL LAMINATE OFFERING

KI offers laminates beyond those offered in the standard offering. Laminates that are currently available in the program can be viewed in KI product specification tools. Requests to add laminates to the program can be submitted via the product modification request process. Please note, requests to add laminates to the program must include the laminate manufacturers name, color/pattern number, and finish code. Edge options are limited to standard edge colors. If a matching edge is required, this will need to be requested thru the product modification request process and may be subject to additional costs. Due to varying manufacturing processes and quality issues with some laminates, some requests may be denied. Extended lead times and minimum order quantities may apply on orders containing special laminates. Contact the product modification team for questions or additional information regarding special laminates and pricing.

SPECIAL SERVICES

Special Carton Marking

With specially marked information N/C

Shipping

Ships assembled, FOB High Point, NC 27263, freight prepaid. Freight class 175

Specifications and prices are subject to change without prior notice.

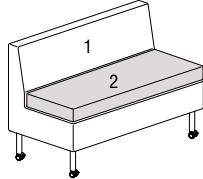
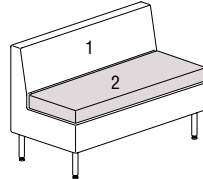

MODEL	Features	MODEL NUMBER							Approx. Packaged Weight	Delivered Pricing	Moisture Barrier add to list price
		Basic Model	Power Option	Power Module Color	Moist. Barrier	Base Finish	Non-Contrast or Fabric Contrast 1	Fabric Contrast 2			
 <p>Slim Seat, Four-Leg on Casters</p> <ul style="list-style-type: none"> • Non-contrast C.O.M = 3.5 yd • 1=Base and Back - C.O.M. = 2.25 yd • 2=Seat - C.O.M. = 1.25 yd <p>Overall Dimensions: W=44" D=22" H=29" Seat Dimensions: W=44" D=16" H=18"</p> <ul style="list-style-type: none"> • Ganging (specify kit separately) 	Non-contrast	TLS600/NC	<input type="checkbox"/> <input type="checkbox"/> <input type="checkbox"/> <input type="checkbox"/>	<input type="checkbox"/> <input type="checkbox"/> <input type="checkbox"/> <input type="checkbox"/>	<input type="checkbox"/> <input type="checkbox"/> <input type="checkbox"/>	<input type="checkbox"/> <input type="checkbox"/>	<input type="checkbox"/> <input type="checkbox"/>	<input type="checkbox"/> <input type="checkbox"/> <input type="checkbox"/>	73.00#	\$ 1997	\$ 410
	Contrast	TLS600/FC	<input type="checkbox"/> <input type="checkbox"/> <input type="checkbox"/> <input type="checkbox"/>	<input type="checkbox"/> <input type="checkbox"/> <input type="checkbox"/> <input type="checkbox"/>	<input type="checkbox"/> <input type="checkbox"/> <input type="checkbox"/>	<input type="checkbox"/> <input type="checkbox"/>		<input type="checkbox"/> <input type="checkbox"/> <input type="checkbox"/>	73.00#	1997	410
TLS6											
 <p>Slim Seat, Four-Leg on Glides</p> <ul style="list-style-type: none"> • Non-contrast C.O.M = 3.5 yd • 1=Base and Back - C.O.M. = 2.25 yd • 2=Seat - C.O.M. = 1.25 yd <p>Overall Dimensions: W=44" D=22" H=29" Seat Dimensions: W=44" D=16" H=18"</p> <ul style="list-style-type: none"> • Ganging (specify kit separately) 	Non-contrast	TLS800/NC	<input type="checkbox"/> <input type="checkbox"/> <input type="checkbox"/> <input type="checkbox"/>	<input type="checkbox"/> <input type="checkbox"/> <input type="checkbox"/> <input type="checkbox"/>	<input type="checkbox"/> <input type="checkbox"/> <input type="checkbox"/>	<input type="checkbox"/> <input type="checkbox"/>	<input type="checkbox"/> <input type="checkbox"/> <input type="checkbox"/>	73.00#	\$ 1997	\$ 410	
	Contrast	TLS800/FC	<input type="checkbox"/> <input type="checkbox"/> <input type="checkbox"/> <input type="checkbox"/>	<input type="checkbox"/> <input type="checkbox"/> <input type="checkbox"/> <input type="checkbox"/>	<input type="checkbox"/> <input type="checkbox"/> <input type="checkbox"/>	<input type="checkbox"/> <input type="checkbox"/>		<input type="checkbox"/> <input type="checkbox"/> <input type="checkbox"/>	73.00#	1997	410
TLS8											
			A	B	C	D	E	F	G		

HOW TO ORDER

Indicate the following information on order form:

1. Quantity of each item.
2. Model number, including options. See "How To Build a Model Number".
3. Any special service required.

Note:

- The indicates that a choice is required.
- The absence of the indicates that no choice is required.
- Alpha-numeric characters in place of indicate that no other alternatives are available.

HOW TO BUILD A MODEL NUMBER

A Select basic model.

B Select power option.

WPFL - Left facing power; add \$333
NP - No power
WPRF - Right facing power; add \$333

C Select power module color.

WPBL - Black/Black power module
WPST - Silver/White power module
WPWH - White/white power module

D Select moisture barrier.

MB - Moisture barrier
NMB - No moisture barrier
 See pricing column for moisture barrier upcharge.

E Select base finish color.
 Refer to the **Product Color Options** page in this price list.

F Select non-contrast or fabric contrast 1.

Refer to ki.com/fabrics.

- For yardage pricing, see Fabric Yardage Pricing page

Refer to ki.com/fabrics.

- For yardage pricing, see Fabric Yardage Pricing page

FINISH INFORMATION

ADDITIONAL LAMINATE OFFERING

KI offers laminates beyond those offered in the standard offering. Laminates that are currently available in the program can be viewed in KI product specification tools. Requests to add laminates to the program can be submitted via the product modification request process. Please note, requests to add laminates to the program must include the laminate manufacturers name, color/pattern number, and finish code. Edge options are limited to standard edge colors. If a matching edge is required, this will need to be requested thru the product modification request process and may be subject to additional costs. Due to varying manufacturing processes and quality issues with some laminates, some requests may be denied. Extended lead times and minimum order quantities may apply on orders containing special laminates. Contact the product modification team for questions or additional information regarding special laminates and pricing.

SPECIAL SERVICES

Special Carton Marking

With specially marked information N/C

Shipping

Ships assembled, FOB High Point, NC 27263, freight prepaid. Freight class 175

Specifications and prices are subject to change without prior notice.

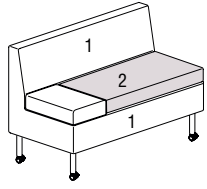
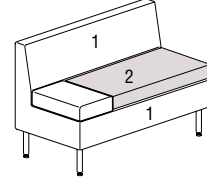

MODEL	Features	MODEL NUMBER								Approx. Packaged Weight	Delivered Pricing	Moisture Barrier add to list price	Laminate Grade 2 add to list price	Laminate Grade 3 add to list price
		Basic Model	Pwr Opt	Pwr Color	Moist. Barrier	Base Finish	Non-Cont or Fabric Cont 1	Fabr Cont 2	Lam. Color					
 TLS6 Slim Seat w/Table, Left-Facing, Four-Leg on Casters • Non-contrast C.O.M = 3.25 yd • 1=Base and Back - C.O.M. = 2.50 yd • 2=Seat - C.O.M. = 1.25 yd Overall Dimensions: W=44" D=22" H=29" Seat Dimensions: W=22" D=16" H=18" Table Dimensions: W=11" D=16" • Ganging (specify kit separately)	Non-contrast	TLS60Q/NC	<input type="checkbox"/>	<input type="checkbox"/>	<input type="checkbox"/>	<input type="checkbox"/>	<input type="checkbox"/>	<input type="checkbox"/>	<input type="checkbox"/>	82.00#	\$ 2574	\$ 410	\$ 19	\$ 120
	Contrast	TLS60Q/FC	<input type="checkbox"/>	<input type="checkbox"/>	<input type="checkbox"/>	<input type="checkbox"/>	<input type="checkbox"/>	<input type="checkbox"/>	<input type="checkbox"/>	<input type="checkbox"/>	82.00#	2574	410	19
 TLS8 Slim Seat w/Table, Left-Facing, Four-Leg on Glides • Non-contrast C.O.M = 3.25 yd • 1=Base and Back - C.O.M. = 2.50 yd • 2=Seat - C.O.M. = 1.25 yd Overall Dimensions: W=44" D=22" H=29" Seat Dimensions: W=22" D=16" H=18" Table Dimensions: W=11" D=16" • Ganging (specify kit separately)	Non-contrast	TLS80Q/NC	<input type="checkbox"/>	<input type="checkbox"/>	<input type="checkbox"/>	<input type="checkbox"/>	<input type="checkbox"/>	<input type="checkbox"/>	<input type="checkbox"/>	82.00#	\$ 2574	\$ 410	\$ 19	\$ 120
	Contrast	TLS80Q/FC	<input type="checkbox"/>	<input type="checkbox"/>	<input type="checkbox"/>	<input type="checkbox"/>	<input type="checkbox"/>	<input type="checkbox"/>	<input type="checkbox"/>	<input type="checkbox"/>	82.00#	2574	410	19

A B C D E F G H

HOW TO ORDER

- Indicate the following information on order form:
- Quantity of each item.
 - Model number, including options. See "How to Build a Model Number".
 - Any special service required.

Note: • The indicates that a choice is required.
 • The absence of the indicates that no choice is required.
 • Alpha-numeric characters in place of indicate that no other alternatives are available.

HOW TO BUILD A MODEL NUMBER

- A** Select basic model.
- B** Select power option.
 WP - With power; add \$333
 NP - No power
- C** Select power module color.
 WPBL - Black/Black power module
 WPSL - Silver/White power module
 WPSL - White/white power module
- D** Select moisture barrier.
 MB - Moisture barrier
 NMB - No moisture barrier
 See pricing column for moisture barrier upcharge.
- E** Select base finish color.
 Refer to the **Product Color Options** page in this price list.
- F** Select non-contrast or fabric contrast 1.
 Refer to **ki.com/fabrics**.

- For yardage pricing, see Fabric Yardage Pricing page
- G** Select fabric contrast 2.
 Refer to **ki.com/fabrics**
 • For yardage pricing, see Fabric Yardage Pricing page
- H** Select laminate color.
 Refer to the **Product Color Options** page in this price list.

FINISH INFORMATION

ADDITIONAL LAMINATE OFFERING

KI offers laminates beyond those offered in the standard offering. Laminates that are currently available in the program can be viewed in KI product specification tools. Requests to add laminates to the program can be submitted via the product modification request process. Please note, requests to add laminates to the program must include the laminate manufacturers name, color/pattern number, and finish code. Edge options are limited to standard edge colors. If a matching edge is required, this will need to be requested thru the product modification request process and may be subject to additional costs. Due to varying manufacturing processes and quality issues with some laminates, some requests may be denied. Extended lead times and minimum order quantities may apply on orders containing special laminates. Contact the product modification team for questions or additional information regarding special laminates and pricing.

SPECIAL SERVICES

Special Carton Marking

With specially marked information N/C

Shipping
 Ships assembled, FOB High Point, NC 27263, freight prepaid. Freight class 175

Specifications and prices are subject to change without prior notice.

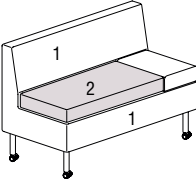
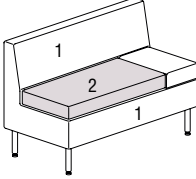

MODEL	Features	MODEL NUMBER								Approx. Packaged Weight	Delivered Pricing	Moisture Barrier add to list price	Laminate Grade 2 add to list price	Laminate Grade 3 add to list price
		Basic Model	Pwr Opt	Pwr Color	Moist Barr	Base Finish	Non-Cont or Fabric Cont 1	Fabric Cont 2	Lam. Color					
 TLS6 Slim Seat w/Table, Right-Facing, Four-Leg on Casters • Non-contrast C.O.M = 3.5 yd • 1=Base and Back - C.O.M. = 2.25 yd • 2=Seat - C.O.M. = 1.25 yd Overall Dimensions: W=44" D=22" H=29" Seat Dimensions: W=22" D=16" H=18" Table Dimensions: W=11" D=16" • Ganging (specify kit separately)	Non-contrast	TLS60R/NC	<input type="checkbox"/>	<input type="checkbox"/>	<input type="checkbox"/>	<input type="checkbox"/>	<input type="checkbox"/>	<input type="checkbox"/>	<input type="checkbox"/>	82.00#	\$ 2574	\$ 410	\$ 19	\$ 120
	Contrast	TLS60R/FC	<input type="checkbox"/>	<input type="checkbox"/>	<input type="checkbox"/>	<input type="checkbox"/>		<input type="checkbox"/>	<input type="checkbox"/>		82.00#	2574	410	19
 TLS8 Slim Seat w/Table, Right-Facing, Four-Leg on Glides • Non-contrast C.O.M = 3.5 yd • 1=Base and Back - C.O.M. = 2.25 yd • 2=Seat - C.O.M. = 1.25 yd Overall Dimensions: W=44" D=22" H=29" Seat Dimensions: W=22" D=16" H=18" Table Dimensions: W=11" D=16" • Ganging (specify kit separately)	Non-contrast	TLS80R/NC	<input type="checkbox"/>	<input type="checkbox"/>	<input type="checkbox"/>	<input type="checkbox"/>	<input type="checkbox"/>	<input type="checkbox"/>	<input type="checkbox"/>	82.00#	\$ 2574	\$ 410	\$ 19	\$ 120
	Contrast	TLS80R/FC	<input type="checkbox"/>	<input type="checkbox"/>	<input type="checkbox"/>	<input type="checkbox"/>		<input type="checkbox"/>	<input type="checkbox"/>		82.00#	2574	410	19
			A	B	C	D	E	F	G	H				

HOW TO ORDER

- Indicate the following information on order form:
- Quantity of each item.
 - Model number, including options. See "How to Build a Model Number".
 - Any special service required.

Note: • The indicates that a choice is required.
 • The absence of the indicates that no choice is required.
 • Alpha-numeric characters in place of indicate that no other alternatives are available.

HOW TO BUILD A MODEL NUMBER

- A** Select basic model.
- B** Select power option.
 WP - With power; add \$333
 NP - No power
- C** Select power module color.
 WPBL - Black/Black power module
 WPSL - Silver/White power module
 WPWH - White/white power module
- D** Select moisture barrier.
 MB - Moisture barrier
 NMB - No moisture barrier
 See pricing column for moisture barrier upcharge.
- E** Select base finish color.
 Refer to the **Product Color Options** page in this price list.
- F** Select non-contrast or fabric contrast 1.
 Refer to **ki.com/fabrics**.

- For yardage pricing, see Fabric Yardage Pricing page
- G** Select fabric contrast 2.
 Refer to **ki.com/fabrics**
 • For yardage pricing, see Fabric Yardage Pricing page
- H** Select laminate color.
 Refer to the **Product Color Options** page in this price list.

FINISH INFORMATION

ADDITIONAL LAMINATE OFFERING

KI offers laminates beyond those offered in the standard offering. Laminates that are currently available in the program can be viewed in KI product specification tools. Requests to add laminates to the program can be submitted via the product modification request process. Please note, requests to add laminates to the program must include the laminate manufacturers name, color/pattern number, and finish code. Edge options are limited to standard edge colors. If a matching edge is required, this will need to be requested thru the product modification request process and may be subject to additional costs. Due to varying manufacturing processes and quality issues with some laminates, some requests may be denied. Extended lead times and minimum order quantities may apply on orders containing special laminates. Contact the product modification team for questions or additional information regarding special laminates and pricing.

SPECIAL SERVICES

Special Carton Marking

With specially marked information N/C

Shipping
 Ships assembled, FOB High Point, NC 27263, freight prepaid. Freight class 175

Specifications and prices are subject to change without prior notice.

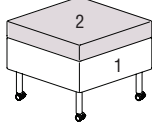
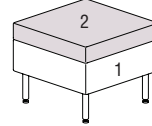

MODEL	Features	MODEL NUMBER					Approx. Packaged Weight	Delivered Pricing	Moisture Barrier add to list price
		Basic Model	Moist. Barrier	Base Finish	Non-Contrast or Fabric Contrast 1	Fabric Contrast 2			
 TL36	Ottoman, Four-Leg on Casters • Non-contrast C.O.M = 2 yd • 1=Base - C.O.M. = 1 yd • 2=Seat - C.O.M. = 1 yd Overall Dimensions: W=22" D=22" H=18" Seat Dimensions: W=22" D=22" H=18"	Non-contrast	TL3600/NC	<input type="checkbox"/> <input type="checkbox"/>	<input type="checkbox"/>	<input type="checkbox"/> <input type="checkbox"/>	35.00#	\$ 1359	\$ 267
		Full-contrast	TL3600/FC	<input type="checkbox"/> <input type="checkbox"/>	<input type="checkbox"/>		<input type="checkbox"/> <input type="checkbox"/>	35.00#	1359
 TL38	Ottoman, Four-Leg on Glides • Non-contrast C.O.M = 2 yd • 1=Base - C.O.M. = 1 yd • 2=Seat - C.O.M. = 1 yd Overall Dimensions: W=22" D=22" H=18" Seat Dimensions: W=22" D=22" H=18"	Non-contrast	TL3800/NC	<input type="checkbox"/> <input type="checkbox"/>	<input type="checkbox"/>	<input type="checkbox"/> <input type="checkbox"/>	35.00#	\$ 1359	\$ 267
		Contrast	TL3800/FC	<input type="checkbox"/> <input type="checkbox"/>	<input type="checkbox"/>		<input type="checkbox"/> <input type="checkbox"/>	35.00#	1359
				A	B	C	D	E	

HOW TO ORDER

Indicate the following information on order form:

- Quantity of each item.
- Model number, including options. See "How To Build a Model Number".
- Any special service required.

Note: • The indicates that a choice is required.

- The absence of the indicates that no choice is required.
- Alpha-numeric characters in place of indicate that no other alternatives are available.

HOW TO BUILD A MODEL NUMBER

- A** Select basic model.
- B** Select moisture barrier.
MB - Moisture barrier
NMB - No moisture barrier
 See pricing column for moisture barrier upcharge.
- C** Select base finish color.
 Refer to the **Product Color Options** page in this price list.
- D** Select non-contrast or fabric contrast 1.
 Refer to ki.com/fabrics.
 • For yardage pricing, see Fabric Yardage Pricing page
- E** Select fabric contrast 2.
 Refer to ki.com/fabrics.
 • For yardage pricing, see Fabric Yardage Pricing page

FINISH INFORMATION

ADDITIONAL LAMINATE OFFERING

KI offers laminates beyond those offered in the standard offering. Laminates that are currently available in the program can be viewed in KI product specification tools. Requests to add laminates to the program can be submitted via the product modification request process. Please note, requests to add laminates to the program must include the laminate manufacturers name, color/pattern number, and finish code. Edge options are limited to standard edge colors. If a matching edge is required, this will need to be requested thru the product modification request process and may be subject to additional costs. Due to varying manufacturing processes and quality issues with some laminates, some requests may be denied. Extended lead times and minimum order quantities may apply on orders containing special laminates. Contact the product modification team for questions or additional information regarding special laminates and pricing.

SPECIAL SERVICES

Special Carton Marking

With specially marked information N/C

Shipping

Ships assembled, FOB High Point, NC 27263, freight prepaid. Freight class 175

Specifications and prices are subject to change without prior notice.

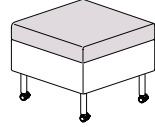
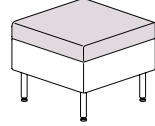

MODEL	MODEL NUMBER							Approx. Packaged Weight	Delivered Pricing	Moisture Barrier add to list price	Laminate Grade 2 add to list price	Laminate Grade 3 add to list price
	Basic Model	Power Option	Power Module Color	Moist. Barrier	Base Finish	Non-Contrast or Fabric Contrast 1	Lam. Color					
 Occasional Table, Four Leg on Casters • Non-contrast C.O.M = 1 yd Overall Dimensions: W=22" D=22" H=18" Table Dimensions: W=22" D=22" H=18" TLE6	TLE600	<input type="checkbox"/>	<input type="checkbox"/>	<input type="checkbox"/>	<input type="checkbox"/>	<input type="checkbox"/>	<input type="checkbox"/>	57.00#	\$ 1859	\$ 186	\$ 19	\$ 120
 Occasional Table, Four Leg on Glides • Non-contrast C.O.M = 1 yd Overall Dimensions: W=22" D=22" H=18" Table Dimensions: W=22" D=22" H=18" TLE8	TLE800	<input type="checkbox"/>	<input type="checkbox"/>	<input type="checkbox"/>	<input type="checkbox"/>	<input type="checkbox"/>	<input type="checkbox"/>	57.00#	\$ 1859	\$ 186	\$ 19	\$ 120
	A	B	C	D	E	F	G					

HOW TO ORDER

- Indicate the following information on order form:
- Quantity of each item.
 - Model number, including options. See "How To Build a Model Number".
 - Any special service required.

Note: • The indicates that a choice is required.
 • The absence of the indicates that no choice is required.
 • Alpha-numeric characters in place of indicate that no other alternatives are available.

HOW TO BUILD A MODEL NUMBER

- A** Select basic model.
- B** Select power option.
 NP - No power
 WP - With power; add \$333
- C** Select power module color.
 WPBL - Black/Black power module
 WPSL - Silver/White power module
 WPWH - White/white power module
- D** Select moisture barrier.
 MB - Moisture barrier
 NMB - No moisture barrier
 See pricing column for moisture barrier upcharge.
- E** Select base finish color.
 Refer to the **Product Color Options** page in this price list.
- F** Select non-contrast or fabric contrast 1.
 Refer to ki.com/fabrics.

• For yardage pricing, see Fabric Yardage Pricing page
G Select laminate color.
 Refer to the **Product Color Options** page in this price list.

FINISH INFORMATION

ADDITIONAL LAMINATE OFFERING

KI offers laminates beyond those offered in the standard offering. Laminates that are currently available in the program can be viewed in KI product specification tools. Requests to add laminates to the program can be submitted via the product modification request process. Please note, requests to add laminates to the program must include the laminate manufacturers name, color/pattern number, and finish code. Edge options are limited to standard edge colors. If a matching edge is required, this will need to be requested thru the product modification request process and may be subject to additional costs. Due to varying manufacturing processes and quality issues with some laminates, some requests may be denied. Extended lead times and minimum order quantities may apply on orders containing special laminates. Contact the product modification team for questions or additional information regarding special laminates and pricing.

SPECIAL SERVICES

Special Carton Marking

With specially marked information N/C

Shipping

Ships assembled, FOB High Point, NC 27263, freight prepaid. Freight class 175

Specifications and prices are subject to change without prior notice.

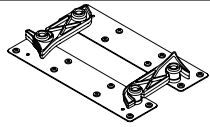

MODEL	MODEL NUMBER	Approx. Packaged Weight	Delivered Pricing
	Basic Model		
 <p>Ganger Assembly</p> <ul style="list-style-type: none"> Order one ganger assembly for each intersecting point Each ganger assembly includes two identical sets of component parts to join two Seating models together 	GNGR.ASSM	2.10#	\$ 78

AC902

A

HOW TO ORDER

- Indicate the following information on order form:
- Quantity of each item.
 - Model number, including options. See "How To Build a Model Number".
 - Any special service required.

- Note:
- The indicates that a choice is required.
 - The absence of the indicates that no choice is required.
 - Alpha-numeric characters in place of indicate that no other alternatives are available.

HOW TO BUILD A MODEL NUMBER

- A** Select basic model.

SPECIAL SERVICES

Special Carton Marking

With specially marked information N/C

Shipping

Ships assembled, FOB High Point, NC 27263, freight prepaid. Freight class 175

Specifications and prices are subject to change without prior notice.



Rectangular
(18" High)



Rectangular
(29" High)



Square
(18" High)



Square
(29" High)

Features				
Fixed	•	•	•	•
Adjustable glides	•	•	•	•
General Dimensions				
Height	18"	29"	18"	29"
Top	30"W x 44"D	30"W x 44"D	30"W x 30"D	30"W x 30"D
Square Base	23"	23"	20"	20"

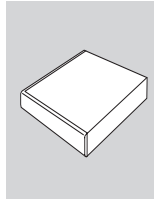

Laminate; 3/4" rigid
Poly edge; square
corner (73P)

INFORMATION

Warranty
Refer to KI Terms & Conditions document or visit
ki.com



TECHNICAL SPECIFICATIONS

Base

The table base assembly consists of a column upright with a base plate at the floor and a table support plate attached at the top, both attach to the column using $\frac{5}{16}$ " - 18 cap head screws. The column is 3" in diameter and is constructed of 14-gauge steel, with threaded straps welded in each end for base and table support plate attachment. The square base plate is constructed of $\frac{1}{4}$ " thick steel plate with $\frac{1}{2}$ " radiused corners and has $\frac{3}{4}$ " steel glide bushings welded near each corner for adjustable glides. All 30" x 44" rectangular tops receive a $23\frac{3}{4}$ " x $23\frac{3}{4}$ " base plate and 30" x 30" tops use a 20" x 20" base plate. The table support plate is of 7-gauge steel and attaches to the underside of the table using #12 x $\frac{3}{4}$ " Phillips pan head screws.

Glides

Adjustable glides are 1" diameter, nickel plated with $\frac{5}{16}$ " stems and offer $\frac{1}{2}$ " of adjustability.

Laminate Table Surfaces

Laminate tops feature a $\frac{3}{4}$ " high-density particleboard core with a .030" thick high-pressure laminate top and a .028" thick phenolic backer (bottom). The table edge is 2mm polypropylene (73P) edge. Tops are pre-drilled for the table bases.

Base Finishes

The base components are finished in electrostatically applied hybrid powdercoating. The coating is then fused and cured in a baking oven to form a smooth, continuous finish that is chemical-resistant, hard, tough and mar-resistant. Powder-coated paint is available in all standard KI paint colors except for chrome.

Compliance

Tattoo Table is designed and manufactured to meet or exceed required ANSI/BIFMA x5.5-2014.

DIMENSIONS

Overall Dimension						
Table Model	A Height	B	C	D	E	F
TADAA3044	29"	29.93"	43.93"	20.5"	10"	3"
TADDA3044	18"	29.93"	43.93"	20.5"	10"	3"
TADAC30	29"	29.93"	29.93"	13.5"	5"	5"
TADDC30	18"	29.93"	29.93"	13.5"	5"	5"

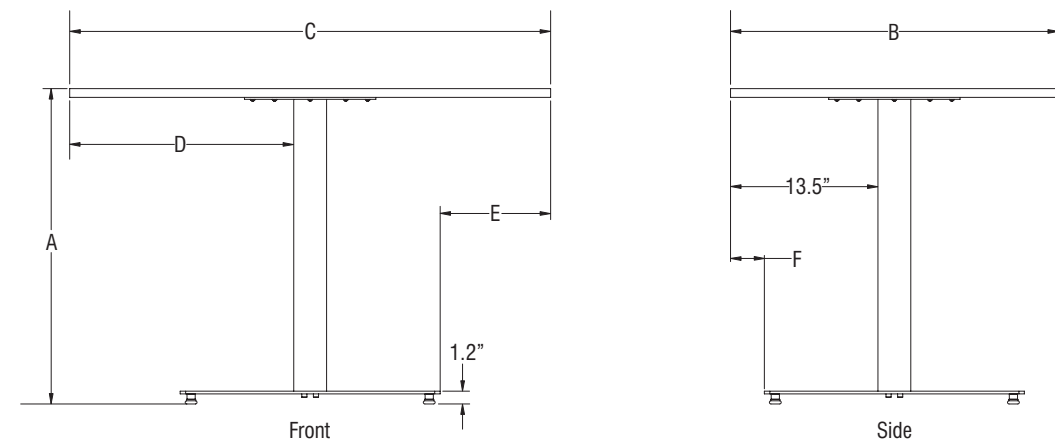

STATEMENT OF LINE

29" Height Table

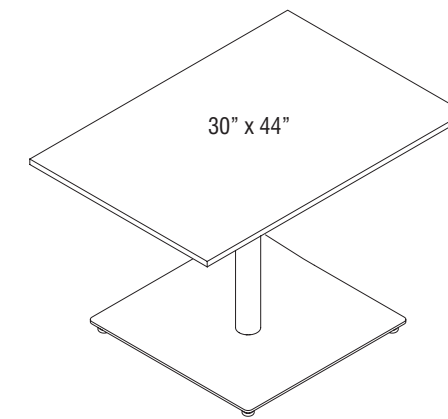

TADAA3044

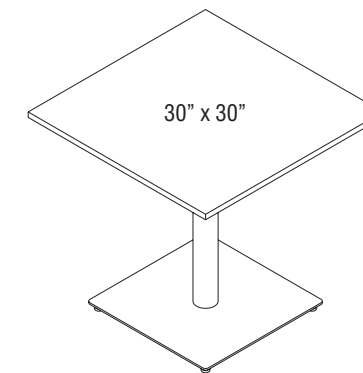

TADAC30

18" Height Table

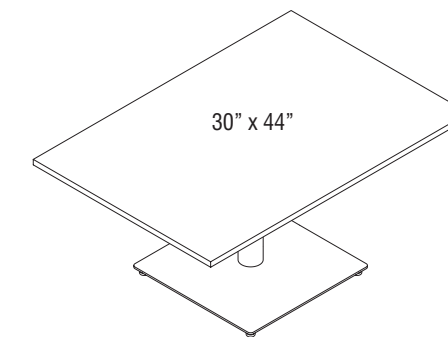

TADDA3044

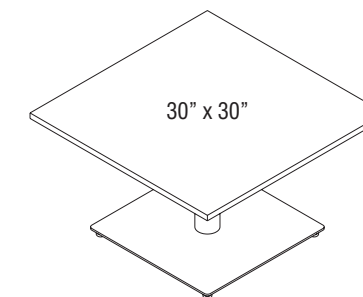

TADDC30

Surface Finish--Grade 1 Standard Laminate

Beigewood
Belair
Biltmore Cherry
Black
Brighton Walnut
Castle Oak
Cherry Storm
Classic Linen
Cocobala
Crisp Linen
Designer White
Dove Grey
Florence Walnut
Friston Ash
Frosty White
Graphite Nebula
Grey
High Rise
Hollyberry
Island
Italian Silver Ash
Kensington Maple
Lapis Blue
Monticello Maple
North Sea
Ocean
Pinnacle Walnut
River Cherry
Shadow Zephyr
Sterling Ash
Titanium Evolv
White Nebula
White Sand
Windsor Mahogany

Surface Finish--Grade 2 Standard Laminate

Akira
Black Alicante
Black Hills Oak
Calcutta Marble
Dering Forest
Fawn Cypress
Ice Mist
Markerboard White
Valley Forge Elm
White River Forest

Surface Finish--Grade 3 Standard Laminate

Black Velvet
Cumberland Walnut
Designer White Velvet
Hartley Walnut
Nile Velvet
Raleigh Walnut
Solano Walnut
Spruce Velvet

Edge Color for 73P Edge

LBZ Akira
LBQ Beigewood
LBT Belair
LBK Biltmore Cherry
LBW Black
LCO Black Hills Oak
LCX Blue Grey
LCI Brighton Walnut
LCC Castle Oak
LRI Cayenne
LDR Cherry Storm
LDG Cocobala
LFC Cool Grey
LFH Cumberland Walnut
LFW Dering Forest
LGN Designer White
LGE Everglade Shade
LHE Fawn Cypress
LHY Flannel
LID Florence Walnut
LIT Friston Ash
LKM Frosty White
LLB Hartley Walnut
LMT Hazy Jade
LNA Italian Silver Ash
LON Kensington Maple
LPW Light Tone
LRV Mardi Gras
LSR Misty Brown
LAZ Monticello Maple
LTV Multiplex
LWL Nemo
LWN Nordic
LWY Pinnacle Walnut

Poppy Red
Rainforest
Raleigh Walnut
River Cherry
Rubber Ducky
Sand
Sky Blue
Solano Walnut
Sterling Ash
Surf's Up
Tarragon
Twilight Shadow
Ultra Blue
Valley Forge Elm
Warm Grey
White River Forest
Windsor Mahogany
Zesty Lime

Base Finish

Black
Blue Grey
Bronze Metallic

EAK Cayenne
EBZ Champagne Metallic
EBQ Cool Grey
EBT Cottonwood
EBL Earthen Clay
EBH Espresso Metallic
EGR Everglade Shade
EBW Flannel
ECO Glitz Metallic
ECY Hazy Jade
ECX Honey Bee
ECC Light Tone
ECG Mardi Gras
ECJ Misty Brown
EDF Nemo
EDR Nordic
EEV Purple Haze
EFQ Rainforest
EFN Raw Jasper
EFC Rubber Ducky
EFH Sand
EFW Starlight Silver Metallic
EHW Surf's Up
EHJ Tarragon
EIT Twilight Shadow
EKM Ultra Blue
ELG Warm Grey
EMG Zesty Lime

ERM
ERN
ERQ
ERW
ERY
ERK
ESA
ESK
ESG
EAZ
ESP
ETQ
ETI
EUB
EVF
EWG
EWR
EWY
EZL

BL
GR
ZM

Finish Cards

View color swatches for items listed within this document.

Paints**Plastics/Poly****Wood/Veneer****Laminates****Molded Edges****Edge Styles****Hard Plastics****Glass**

Certain options referenced may not be available on GSA Schedule.

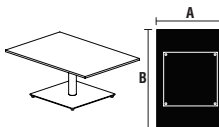
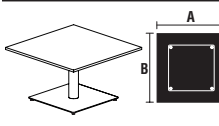

MODEL	A x B	MODEL NUMBER					Approx. Packaged Weight	Delivered Pricing	Laminate Grade 2 add to list price	Laminate Grade 3 add to list price	
		Basic Model	Edge Style	Edge Color	Surface Finish	Base Finish					
 <p>Rectangle Table</p> <ul style="list-style-type: none"> • 3" column • 23" square base • Adjustable glides <p>TADDA</p>	30 x 44"	TADDA3044	73P	<input type="checkbox"/> <input type="checkbox"/> <input type="checkbox"/>		<input type="checkbox"/> <input type="checkbox"/>	86.6#	\$ 999	\$ 27	\$ 178	
 <p>Square Table</p> <ul style="list-style-type: none"> • 3" column • 20" square base • Adjustable glides <p>TADDC</p>	30 x 30"	TADDC30	73P	<input type="checkbox"/> <input type="checkbox"/> <input type="checkbox"/>		<input type="checkbox"/> <input type="checkbox"/>	64.5#	\$ 888	\$ 27	\$ 178	

A **B** **C** **D** **E**

HOW TO ORDER

- Indicate the following information on order form:
1. Quantity of each item.
 2. Model number, including options. See "How To Build a Model Number".
 3. Any special service required.

Note:

- The indicates that a choice is required.
- The absence of the indicates that no choice is required.
- Alpha-numeric characters in place of indicate that no other alternatives are available.

HOW TO BUILD A MODEL NUMBER

- A** Select basic model.
- B** Select edge style.
73P - 73P edge
- C** Select edge color.
Refer to the **Product Color Options** page in this price list.
- D** Select surface finish.
Refer to the **Product Color Options** page in this price list.
- E** Select base finish.
Refer to the **Product Color Options** page in this price list.

SPECIAL SERVICES

Special Carton Marking

With specially marked information N/C

Shipping

Ships assembled, FOB Bondue1, WI 54107, freight prepaid. Freight class 70.

Specifications and prices are subject to change without prior notice.

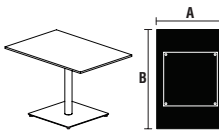
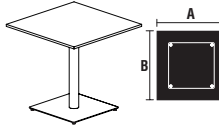

MODEL	A x B	MODEL NUMBER					Approx. Packaged Weight	Delivered Pricing	Laminate Grade 2 add to list price	Laminate Grade 3 add to list price	
		Basic Model	Edge Style	Edge Color	Surface Finish	Base Finish					
 <p>Rectangle Table</p> <ul style="list-style-type: none"> • 3" column • 23" square base • Adjustable glides <p>TADAA</p>	30 x 44"	TADAA3044	73P	<input type="checkbox"/> <input type="checkbox"/> <input type="checkbox"/>		<input type="checkbox"/> <input type="checkbox"/>	89.4#	\$ 1026	\$ 27	\$ 178	
 <p>Square Table</p> <ul style="list-style-type: none"> • 3" column • 20" square base • Adjustable glides <p>TADAC</p>	30 x 30"	TADAC30	73P	<input type="checkbox"/> <input type="checkbox"/> <input type="checkbox"/>		<input type="checkbox"/> <input type="checkbox"/>	67.3#	\$ 916	\$ 27	\$ 178	

A **B** **C** **D** **E**

HOW TO ORDER

- Indicate the following information on order form:
1. Quantity of each item.
 2. Model number, including options. See "How To Build a Model Number".
 3. Any special service required.

Note:

- The indicates that a choice is required.
- The absence of the indicates that no choice is required.
- Alpha-numeric characters in place of indicate that no other alternatives are available.

HOW TO BUILD A MODEL NUMBER

- A** Select basic model.
- B** Select edge style.
73P - 73P edge
- C** Select edge color.
Refer to the **Product Color Options** page in this price list.
- D** Select surface finish.
Refer to the **Product Color Options** page in this price list.
- E** Select base finish.
Refer to the **Product Color Options** page in this price list.

SPECIAL SERVICES

Special Carton Marking

With specially marked information N/C

Shipping

Ships assembled, FOB Bondue1, WI 54107, freight prepaid. Freight class 70.

Specifications and prices are subject to change without prior notice.



TECHNICAL SPECIFICATIONS

Toggle Dual & Triple Motor Electric-Base (Model EL, ELC & SS)

General

The Model EL table consists of two adjustable height T-bases (centered column on a horizontal foot). The Model ELC table consists of two adjustable height C-Bases (off centered column on a horizontal foot). Bases attach to a tabletop support that spans the two bases. The Model SS table consists of three adjustable height C-Bases (off centered column on a horizontal foot). Bases attach to the tabletop support that spans the three bases. All tabletops adjust between 25" and 51" from the floor by means of electric controls that can be located at either end of the table.

Base

The base consists of a column assembly and foot both finished with baked-on 30-sheen powder-coat paint. The column assembly consists of an outer member, an intermediate member and an inner member. The outer member consists of a 2³/₈" x 4³/₈" rectangular 14-gauge steel tubing with a 1/4" steel plate welded on the top end. The intermediate member consists of a 2" x 4" rectangular 14-gauge steel tubing. The inner member consists of a 1 1/2" x 3 1/2" rectangular 14-gauge steel tubing with a 1/4" steel plate welded on the bottom end. A 6-gauge formed steel motor housing is welded to each outer leg member for strength. The foot consists of an extruded aluminum component with a nylon toe cap inserted into each end. The foot is attached to the column with four 6 mm bolts. Two 1 1/2" diameter nylon base leveling glides are threaded into the foot.

Tabletop Support

The tabletop support consists of a 14-gauge 1" x 1" steel tubing attached to each leg column with 6 mm bolts. An 11-gauge U-shaped cross member connects each leg assembly for stability.

Tabletop

Tabletops are constructed with 1 1/8" thick 45 lb density particleboard core. The top surface is covered with high-pressure laminate. The bottom surface is covered with a phenolic backing sheet. The perimeter is finished using high-impact plastic edging. Model EL and ELC tabletops are pre-drilled and attached to the bases using eight M5.5 x 22 pan head screws. Model SS tabletops are pre-drilled and attached to the bases using sixteen M5.5 x 22 pan head screws.

Control Box

Tables ship standard with a compact corded two-button remote control switch. This allows two switch options for every customer. All table control switches come standard with programmable container/shelf stop, and ISP (Intelligent System Protection). The stand-by power consumption of the control box is 0.3 watts. Power cord length is 120" with a 3-prong. Refer to "Toggle Control Unit Product Specifications" (KI-62686) for more details.

Wire Trough

The wire trough is an optional accessory which must be ordered separately. Constructed of 18-gauge steel with a powder-coated finish which may be coordinated to match the color of table legs. Screws are provided for attachment to the underside of the tabletop, and tops are pre-drilled for wire trough locations. Provides six access holes to feed wires or install cable management systems.

Polyester Felt Modesty Panel

Modesty panels are constructed from a sound-absorbing, 100% polyester felt. The panels have a density of 0.5 lb/ft³ and is sound absorbing tested to ASTM C423 with an NRC rating of .44 when using no air gap (A Mount testing method) and an NRC rating of .81" with 2" air gap. The polyester felt is in accordance with ASTM-E84 and achieve a Class A Flame Spread. Standard sizes are 9 1/4" high by 46 1/2", 52 1/2", 58 1/2", 64 1/2", 70 1/2" and 82 1/2" wide.

Mounting Hooks

The mounting hooks are 18-gauge steel and attach underneath the tabletop using two steel screws. Panels 46 1/2" wide use two hooks per panel. Panels 52 1/2", 58 1/2", 64 1/2", 70 1/2" and 82 1/2" wide use three hooks per panel.

TECHNICAL SPECIFICATIONS

Dual Motor T-Leg Electric-Base Table Operating Capacity Chart

Model Number	Operating Load Capacity
TOGL2448EL	220 lb
TOGL2454EL	215 lb
TOGL2460EL	210 lb
TOGL2466EL	205 lb
TOGL2472EL	200 lb
TOGL3048EL	210 lb
TOGL3054EL	205 lb
TOGL3060EL	200 lb
TOGL3066EL	192 1/2 lb
TOGL3072EL	185 lb
TOGL3648EL	200 lb
TOGL3654EL	192 1/2 lb
TOGL3660EL	185 lb
TOGL3666EL	177 1/2 lb
TOGL3672EL	170 lb
TOGLC3048ELC	180 lb

Dual Motor C-Leg Electric-Base Table Operating Capacity Chart

Model Number	Operating Load Capacity
TOGL2448ELC	220 lb
TOGL2454ELC	215 lb
TOGL2460ELC	210 lb
TOGL2466ELC	205 lb
TOGL2472ELC	200 lb
TOGL3048ELC	210 lb
TOGL3054ELC	205 lb
TOGL3060ELC	200 lb
TOGL3066ELC	192 1/2 lb
TOGL3072ELC	185 lb
TOGL3648ELC	200 lb
TOGL3654ELC	192 1/2 lb
TOGL3660ELC	185 lb
TOGL3666ELC	177 1/2 lb
TOGL3672ELC	170 lb
TOGLC3048ELC	180 lb

Triple Motor C-Leg Electric-Base Square Shoe Table Operating Capacity Chart

Model Number	Operating Load Capacity
TOGLSS244860	260 lb
TOGLSS244866	255 lb
TOGLSS244872	250 lb
TOGLSS244884	240 lb
TOGLSS246048	260 lb
TOGLSS246648	255 lb
TOGLSS247248	250 lb
TOGLSS248448	240 lb
TOGLSS304860	250 lb
TOGLSS304866	245 lb
TOGLSS304872	235 lb
TOGLSS304884	225 lb
TOGLSS306048	250 lb
TOGLSS306648	245 lb
TOGLSS307248	235 lb
TOGLSS308448	225 lb

TECHNICAL SPECIFICATIONS
Toggle Fixed-Base (Model FX)
General

The table consists of two T-bases (centered column on a horizontal foot) supporting a tabletop. The top of the tabletop is 29" from the floor. See page 11 for top sizes.

Base

The base consists of a top plate, column and foot all finished with baked-on 30-sheen powder-coat paint. The top plate is 6-gauge thick steel. The column consists of a 2³/₈" x 4³/₈" rectangular 14-gauge steel tubing with a 1/4" thick steel plate welded on the bottom and top end. The top plate is attached to the column with four 6 mm bolts. The foot consists of an extruded aluminum component with a nylon toe cap inserted into each end. The foot is attached to the column with four 6 mm bolts. Two 1 1/2" diameter nylon base leveling glides are threaded into the foot.

Tabletop

Tabletops are constructed with 1 1/8" thick 45 lb density particleboard core. The top surface is covered with high-pressure laminate. The bottom surface is covered with a phenolic backing sheet. The perimeter is finished using high impact plastic edging. The tabletop is pre-drilled and attached to each mounting plate using seven #10 x 1" tapping screws.

Wire Trough

The wire trough is an optional accessory which must be ordered separately. Constructed of 18-gauge steel with a powder-coated finish which may be coordinated to match the color of table legs. Screws are provided for attachment to the underside of the tabletop, and tops are pre-drilled for wire trough locations.

Polyester Felt Modesty Panel

Modesty panels are constructed from a sound-absorbing, 100% polyester felt. The panels have a density of 0.5 lb/ft³ and is sound absorbing tested to ASTM C423 with an NRC rating of .44 when using no air gap (A Mount testing method) and an NRC rating of .81" with 2" air gap. The polyester felt is in accordance with ASTM-E84 and achieve a Class A Flame Spread. Standard sizes are 9 1/4" high by 46 1/2", 52 1/2", 58 1/2", 64 1/2", 70 1/2" and 82 1/2" wide.

Mounting Hooks

The mounting hooks are 18-gauge steel and attach underneath the tabletop using two steel screws. Panels 46 1/2" wide use two hooks per panel. Panels 52 1/2", 58 1/2", 64 1/2", 70 1/2" and 82 1/2" wide use three hooks per panel.

TECHNICAL SPECIFICATIONS
Wire Trough Placement on Dual Motor Electric-Base Tables (Model EL & ELC)

For Dual Motor Electric-Base Tables, an optional wire trough can be mounted directly over the cross support tubes. For 36" deep rectangular tables and 120-degree tables, the optional wire trough may also be mounted behind the cross support tubes if desired.

29" wire trough
(mounted over the
cross support tubes)

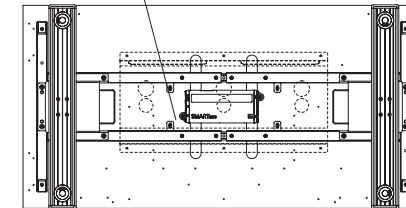

**Rectangular Dual Motor Electric-Base Tables,
24"-36" Deep (24" x 48" Model EL shown)**

29" wire trough
(mounted over the back
cross support tube)

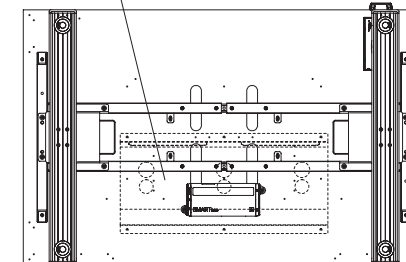

**Rectangular Dual Motor Electric-Base Tables,
30"-36" Deep (30" x 48" Model EL shown)**

36" wire trough
(mounted behind the telescopic
adjustable axle and cross support tube)

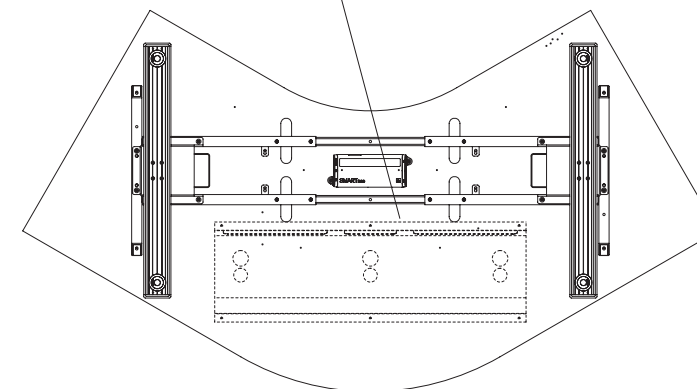

120° Dual Motor Electric-Base Tables, 30" Deep (30" x 48" Model CELC shown)



TECHNICAL SPECIFICATIONS

Wire Trough Placement on Fixed-Base Tables (Model FX)

For 60" and 72" wide Fixed-Base Tables, an optional wire trough can be mounted centered or along the rear edge of the tabletop. The optional wire troughs are not available for 48" wide rectangular tables due to insufficient clearance between the leg mounting plates.

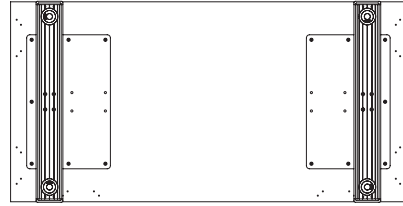

**Rectangular Fixed-Base Tables,
48" Wide (24" x 48" Model FX shown)**

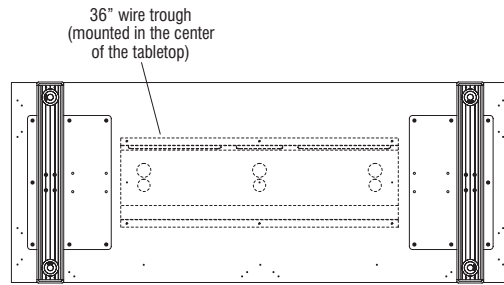

**Rectangular Fixed-Base Tables,
60"-72" Wide (24" x 60" Model FX shown)**

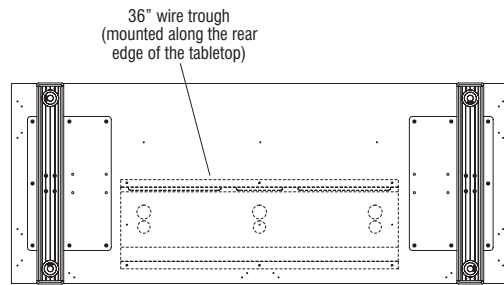

**Rectangular Fixed-Base Tables,
60"-72" Wide (24" x 60" Model FX shown)**

TECHNICAL SPECIFICATIONS

Wire Trough Placement on Triple Motor Electric-Base Tables (Model SS)

For Triple Motor Electric-Base Tables, an optional wire trough can be mounted directly over the cross support tubes on the left- and right-hand side of the table. Reference the chart below to specify wire troughs for all applicable Triple Motor Electric-Base Table models. The tabletops below will have appropriate pre-drilled holes to accept the wire trough listed.

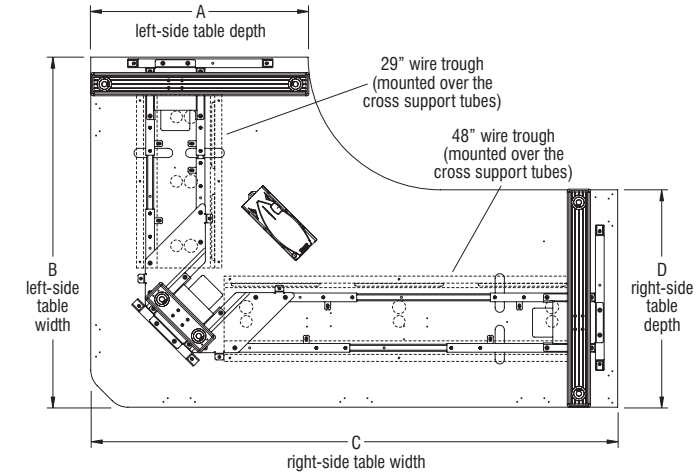

**Square Shoe Triple Motor Electric-Base Tables,
(30" x 48" x 72" Model SS shown)**

**Triple Motor C-Leg Electric-Base Square Shoe Table
Wire Trough Chart**

Model Number	Left-Side Wire Trough	Right-Side Wire Trough
TOGLSS244860	24"	36"
TOGLSS244866	24"	36"
TOGLSS244872	24"	48"
TOGLSS244884	24"	48"
TOGLSS246048	36"	24"
TOGLSS246648	36"	24"
TOGLSS247248	48"	24"
TOGLSS248448	48"	24"
TOGLSS304860	24"	36"
TOGLSS304866	24"	36"
TOGLSS304872	24"	48"
TOGLSS304884	24"	48"
TOGLSS306048	36"	24"
TOGLSS306648	36"	24"
TOGLSS307248	48"	24"
TOGLSS308448	48"	24"



TECHNICAL SPECIFICATIONS

Universal Height-Adjustable Screen on Triple Motor Electric-Base Tables (Model SS)

Reference chart below to specify the privacy screens for all applicable Triple Motor Electric-Base Table models. The tabletops below will have appropriate pre-drilled holes to accept the Universal Height-Adjustable Privacy Screen Model listed.

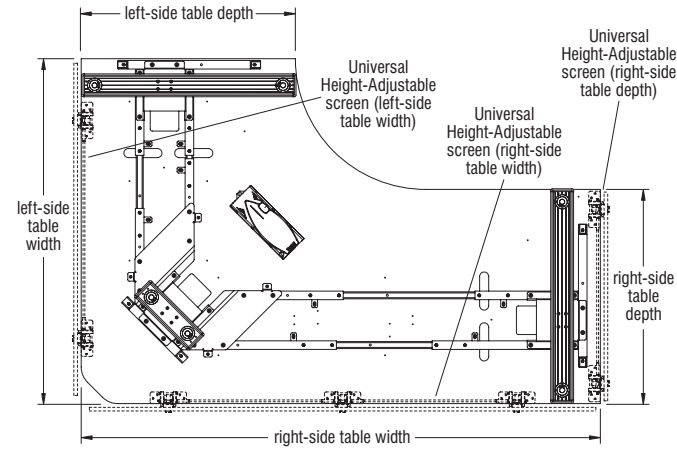

Square Shoe Triple Motor Electric-Base Tables, (30" x 48" x 72" Model SS shown)

Triple Motor C-Leg Electric-Base Square Shoe Table Universal Height-Adjustable Screen Chart

Model Number	Left-Side Table Depth Universal Height-Adjustable Screen	Right-Side Table Depth Universal Height-Adjustable Screen	Left-Side Table Width Universal Height-Adjustable Screen	Right-Side Table Width Universal Height-Adjustable Screen
TOGLSS244860	NA	USPF2324	USPF4624	USPF5824
TOGLSS244866	NA	USPF2324	USPF4624	USPF6424
TOGLSS244872	NA	USPF2324	USPF4624	USPF7024
TOGLSS244884	NA	USPF2324	USPF4624	USPF8224
TOGLSS246048	USPF2324	NA	USPF5824	USPF4624
TOGLSS246648	USPF2324	NA	USPF6424	USPF4624
TOGLSS247248	USPF2324	NA	USPF7024	USPF4624
TOGLSS248448	USPF2324	NA	USPF8224	USPF4624
TOGLSS304860	NA	USPF2924	USPF4624	USPF5824
TOGLSS304866	NA	USPF2924	USPF4624	USPF6424
TOGLSS304872	NA	USPF2924	USPF4624	USPF7024
TOGLSS304884	NA	USPF2924	USPF4624	USPF8224
TOGLSS306048	USPF2924	NA	USPF5824	USPF4624
TOGLSS306648	USPF2924	NA	USPF6424	USPF4624
TOGLSS307248	USPF2924	NA	USPF7024	USPF4624
TOGLSS308448	USPF2924	NA	USPF8224	USPF4624

DIMENSIONS - Dual Motor T-Leg Electric-Base Table (Model EL)

Statement of Line Measurements											
Dimension	Model Number	A Table Depth	B Table Width	C Between Legs	D Between Feet	E Tabletop-to-Leg	F Tabletop-to-Foot	G Tabletop-to-Support	H Foot Size	I Front Edge of Worksurface-to-Leg	J Back Edge of Worksurface-to-Leg
24 x 48"	TOGL2448EL	23.5"	46.5"	35"	33.31"	3.84"	3.45"	1.60"	23.625"	12.9"	12.9"
24 x 54"	TOGL2454EL	23.5"	52.5"	41"	39.31"	3.84"	3.45"	1.60"	23.625"	12.9"	12.9"
24 x 60"	TOGL2460EL	23.5"	58.5"	47"	45.31"	3.84"	3.45"	1.60"	23.625"	12.9"	12.9"
24 x 66"	TOGL2466EL	23.5"	64.5"	53"	51.31"	3.84"	3.45"	1.60"	23.625"	12.9"	12.9"
24 x 72"	TOGL2472EL	23.5"	70.5"	59"	57.31"	3.84"	3.45"	1.60"	23.625"	12.9"	12.9"
30 x 48"	TOGL3048EL	29.5"	46.5"	35"	33.31"	3.84"	3.45"	1.60"	29.625"	15.9"	15.9"
30 x 54"	TOGL3054EL	29.5"	52.5"	41"	39.31"	3.84"	3.45"	1.60"	29.625"	15.9"	15.9"
30 x 60"	TOGL3060EL	29.5"	58.5"	47"	45.31"	3.84"	3.45"	1.60"	29.625"	15.9"	15.9"
30 x 66"	TOGL3066EL	29.5"	64.5"	53"	51.31"	3.84"	3.45"	1.60"	29.625"	15.9"	15.9"
30 x 72"	TOGL3072EL	29.5"	70.5"	59"	57.31"	3.84"	3.45"	1.60"	29.625"	15.9"	15.9"
36 x 48"	TOGL3648EL	35.5"	46.5"	35"	33.31"	3.84"	3.45"	1.60"	29.625"	18.9"	18.9"
36 x 54"	TOGL3654EL	35.5"	52.5"	41"	39.31"	3.84"	3.45"	1.60"	29.625"	18.9"	18.9"
36 x 60"	TOGL3660EL	35.5"	58.5"	47"	45.31"	3.84"	3.45"	1.60"	29.625"	18.9"	18.9"
36 x 66"	TOGL3666EL	35.5"	64.5"	53"	51.31"	3.84"	3.45"	1.60"	29.625"	18.9"	18.9"
36 x 72"	TOGL3672EL	35.5"	70.5"	59"	57.31"	3.84"	3.45"	1.60"	29.625"	18.9"	18.9"
30 x 48"	TOGLC3048ELC	44.16"	80.5"	47"	45.31"	14.86"	14.47"	12.62"	29.625"	16.33"	23.49"

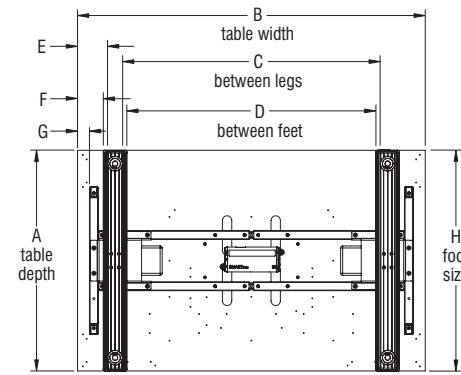

Rectangular Dual Motor T-Leg Electric-Base Table

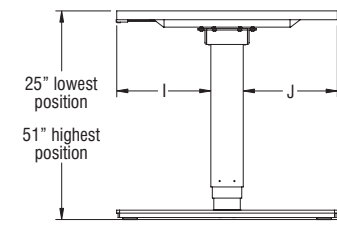

Rectangular Dual Motor T-Leg Electric-Base Table

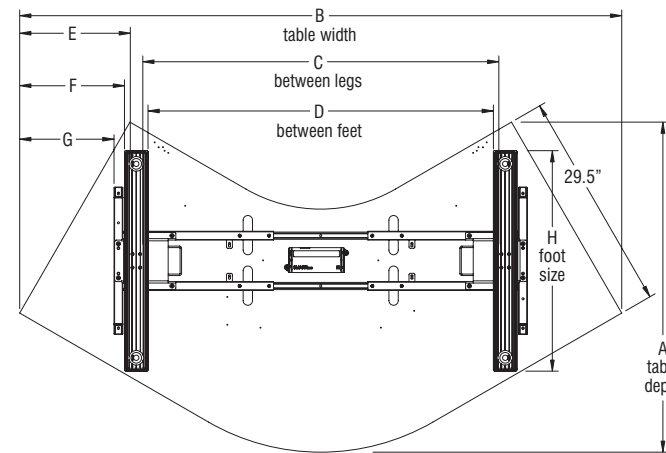

120° Corner Dual Motor T-Leg Electric-Base Table

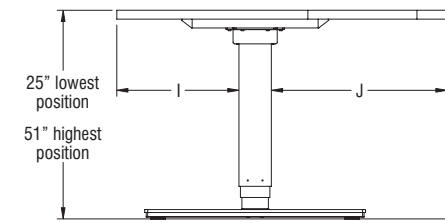

120° Corner Dual Motor T-Leg Electric-Base Table



DIMENSIONS - Dual Motor C-Leg Electric-Base Table (Model ELC)

Statement of Line Measurements											
Dimension	Model Number	A Table Depth	B Table Width	C Between Legs	D Between Feet	E Tabletop-to-Leg	F Tabletop-to-Foot	G Tabletop-to-Support	H Foot Size	I Front Edge of Worksurface-to-Leg	J Back Edge of Worksurface-to-Leg
24 x 48"	TOGL2448ELC	23.5"	46.5"	35"	33.31"	3.84"	3.45"	1.60"	23.625"	12.9"	6.24"
24 x 54"	TOGL2454ELC	23.5"	52.5"	41"	39.31"	3.84"	3.45"	1.60"	23.625"	12.9"	6.24"
24 x 60"	TOGL2460ELC	23.5"	58.5"	47"	45.31"	3.84"	3.45"	1.60"	23.625"	12.9"	6.24"
24 x 66"	TOGL2466ELC	23.5"	64.5"	53"	51.31"	3.84"	3.45"	1.60"	23.625"	12.9"	6.24"
24 x 72"	TOGL2472ELC	23.5"	70.5"	59"	57.31"	3.84"	3.45"	1.60"	23.625"	12.9"	6.24"
30 x 48"	TOGL3048ELC	29.5"	46.5"	35"	33.31"	3.84"	3.45"	1.60"	29.625"	15.9"	9.24"
30 x 54"	TOGL3054ELC	29.5"	52.5"	41"	39.31"	3.84"	3.45"	1.60"	29.625"	15.9"	9.24"
30 x 60"	TOGL3060ELC	29.5"	58.5"	47"	45.31"	3.84"	3.45"	1.60"	29.625"	15.9"	9.24"
30 x 66"	TOGL3066ELC	29.5"	64.5"	53"	51.31"	3.84"	3.45"	1.60"	29.625"	15.9"	9.24"
30 x 72"	TOGL3072ELC	29.5"	70.5"	59"	57.31"	3.84"	3.45"	1.60"	29.625"	15.9"	9.24"
36 x 48"	TOGL3648ELC	35.5"	46.5"	35"	33.31"	3.84"	3.45"	1.60"	29.625"	18.9"	12.24"
36 x 54"	TOGL3654ELC	35.5"	52.5"	41"	39.31"	3.84"	3.45"	1.60"	29.625"	18.9"	12.24"
36 x 60"	TOGL3660ELC	35.5"	58.5"	47"	45.31"	3.84"	3.45"	1.60"	29.625"	18.9"	12.24"
36 x 66"	TOGL3666ELC	35.5"	64.5"	53"	51.31"	3.84"	3.45"	1.60"	29.625"	18.9"	12.24"
36 x 72"	TOGL3672ELC	35.5"	70.5"	59"	57.31"	3.84"	3.45"	1.60"	29.625"	18.9"	12.24"
30 x 48"	TOGLC3048ELC	44.16"	80.5"	47"	45.31"	14.86"	14.47"	12.62"	29.625"	19.68"	20.15"

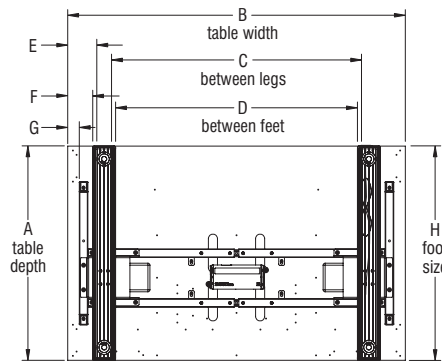

Rectangular Dual Motor C-Leg Electric-Base Table

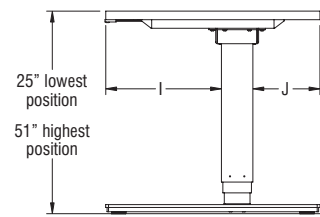

Rectangular Dual Motor C-Leg Electric-Base Table

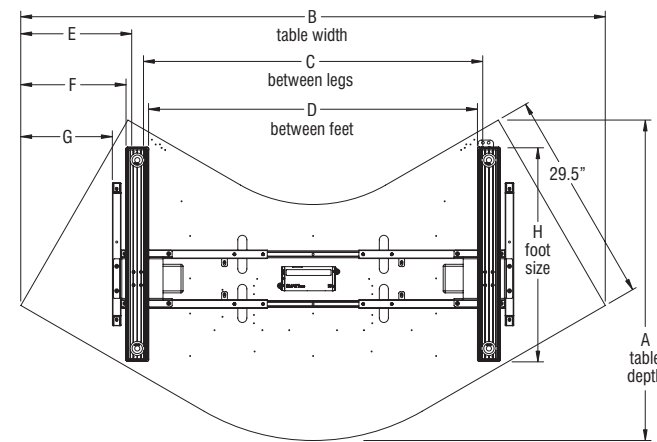

120° Corner Dual Motor C-Leg Electric-Base Table

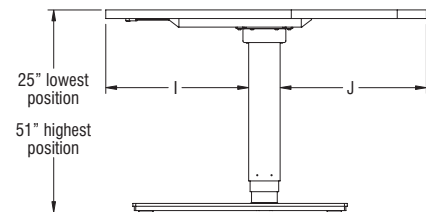

120° Corner Dual Motor C-Leg Electric-Base Table

DIMENSIONS - Triple Motor C-Leg Electric-Base Table (Model SS)

Statement of Line Measurements								
Dimension	Model Number	A Left-Side Table Depth	B Left-Side Table Width	C Right-Side Table Width	D Right-Side Table Depth	E Left-Side Between Legs	F Right-Side Between Legs	G Foot Size
24 x 48 x 60"	TOGLSS244860	23.5"	47.5"	59.5"	23.5"	31"	43"	23.625"
24 x 48 x 66"	TOGLSS244866	23.5"	47.5"	65.5"	23.5"	31"	49"	23.625"
24 x 48 x 72"	TOGLSS244872	23.5"	47.5"	71.5"	23.5"	31"	55"	23.625"
24 x 48 x 84"	TOGLSS244884	23.5"	47.5"	83.5"	23.5"	31"	67"	23.625"
24 x 60 x 48"	TOGLSS246048	23.5"	59.5"	47.5"	23.5"	43"	31"	23.625"
24 x 66 x 48"	TOGLSS246648	23.5"	65.5"	47.5"	23.5"	49"	31"	23.625"
24 x 72 x 48"	TOGLSS247248	23.5"	71.5"	47.5"	23.5"	55"	31"	23.625"
24 x 84 x 48"	TOGLSS248448	23.5"	83.5"	47.5"	23.5"	67"	31"	23.625"
30 x 48 x 60"	TOGLSS304860	29.5"	47.5"	59.5"	29.5"	31"	43"	29.625"
30 x 48 x 66"	TOGLSS304866	29.5"	47.5"	65.5"	29.5"	31"	49"	29.625"
30 x 48 x 72"	TOGLSS304872	29.5"	47.5"	71.5"	29.5"	31"	55"	29.625"
30 x 48 x 84"	TOGLSS304884	29.5"	47.5"	83.5"	29.5"	31"	67"	29.625"
30 x 60 x 48"	TOGLSS306048	29.5"	59.5"	47.5"	29.5"	43"	31"	29.625"
30 x 66 x 48"	TOGLSS306648	29.5"	65.5"	47.5"	29.5"	49"	31"	29.625"
30 x 72 x 48"	TOGLSS307248	29.5"	71.5"	47.5"	29.5"	55"	31"	29.625"
30 x 84 x 48"	TOGLSS308448	29.5"	83.5"	47.5"	29.5"	67"	31"	29.625"

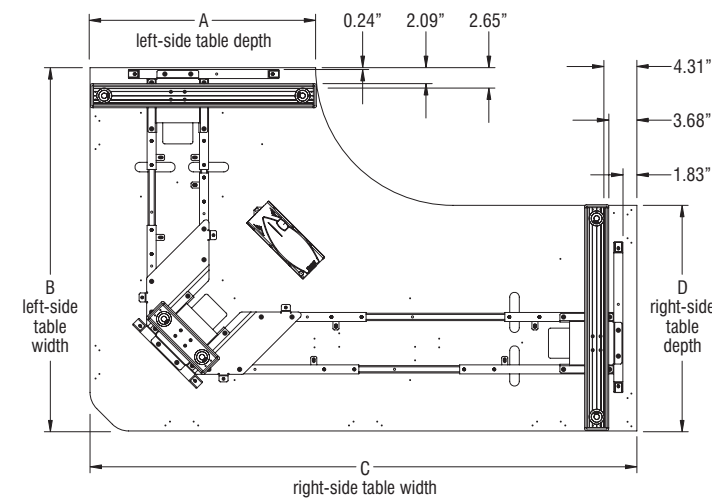

Square Shoe Triple Motor Electric-Base Table

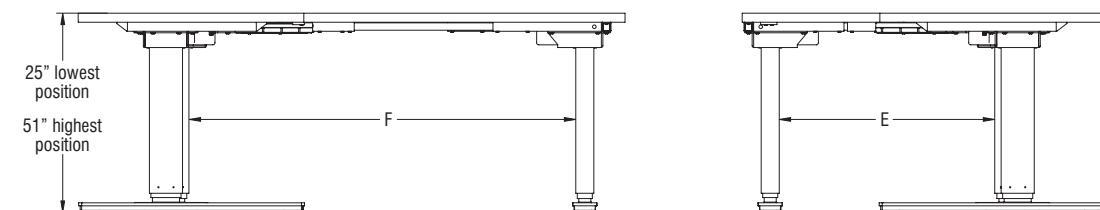

Square Shoe Triple Motor C-Leg Electric-Base Table



DIMENSIONS - Fixed-Base Table (Model FX)

Statement of Line Measurements										
Dimension	Model Number	A Table Depth	B Table Width	C Between Legs	D Between Feet	E Tabletop- to-Leg	F Tabletop- to-Foot	G Foot Size	H Front Edge of Worksurface-to-Leg	I Back Edge of Worksurface-to-Leg
24 x 48"	TOGL2448FX	23.5"	46.5"	35"	34.21"	3.39"	3"	23.625"	9.59"	9.59"
24 x 54"	TOGL2454FX	23.5"	52.5"	41"	40.21"	3.39"	3"	23.625"	9.59"	9.59"
24 x 60"	TOGL2460FX	23.5"	58.5"	47"	46.21"	3.39"	3"	23.625"	9.59"	9.59"
24 x 66"	TOGL2466FX	23.5"	64.5"	53"	52.21"	3.39"	3"	23.625"	9.59"	9.59"
24 x 72"	TOGL2472FX	23.5"	70.5"	59"	58.21"	3.39"	3"	23.625"	9.59"	9.59"
30 x 48"	TOGL3048FX	29.5"	46.5"	35"	34.21"	3.39"	3"	29.625"	12.59"	12.59"
30 x 54"	TOGL3054FX	29.5"	52.5"	41"	40.21"	3.39"	3"	29.625"	12.59"	12.59"
30 x 60"	TOGL3060FX	29.5"	58.5"	47"	46.21"	3.39"	3"	29.625"	12.59"	12.59"
30 x 66"	TOGL3066FX	29.5"	64.5"	53"	52.21"	3.39"	3"	29.625"	12.59"	12.59"
30 x 72"	TOGL3072FX	29.5"	70.5"	59"	58.21"	3.39"	3"	29.625"	12.59"	12.59"
36 x 48"	TOGL3648FX	35.5"	46.5"	35"	34.21"	3.39"	3"	29.625"	15.59"	15.59"
36 x 54"	TOGL3654FX	35.5"	52.5"	41"	40.21"	3.39"	3"	29.625"	15.59"	15.59"
36 x 60"	TOGL3660FX	35.5"	58.5"	47"	46.21"	3.39"	3"	29.625"	15.59"	15.59"
36 x 66"	TOGL3666FX	35.5"	64.5"	53"	52.21"	3.39"	3"	29.625"	15.59"	15.59"
36 x 72"	TOGL3672FX	35.5"	70.5"	59"	58.21"	3.39"	3"	29.625"	15.59"	15.59"

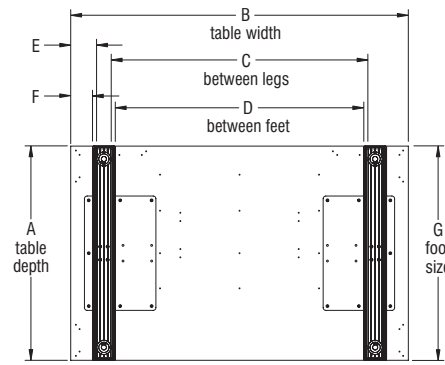

Rectangular Fixed-Base Table

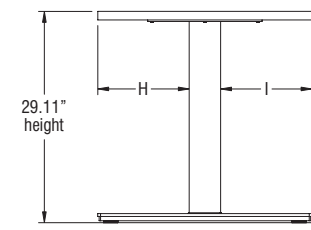

Rectangular Fixed-Base Table

DIMENSIONS - Wire Trough

Wire Trough Width	Dual Motor Table Width
24"	48"
36"	60"
48"	72"

Wire Trough Width	Fixed Table Width
36"	60"
48"	72"

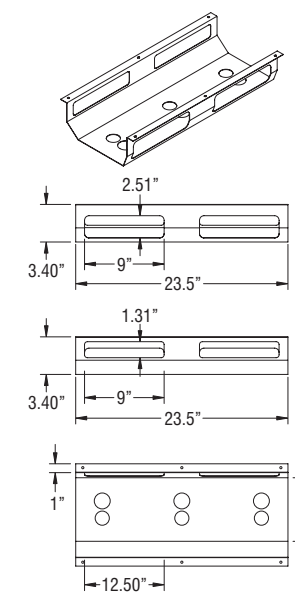

24" Wire Trough

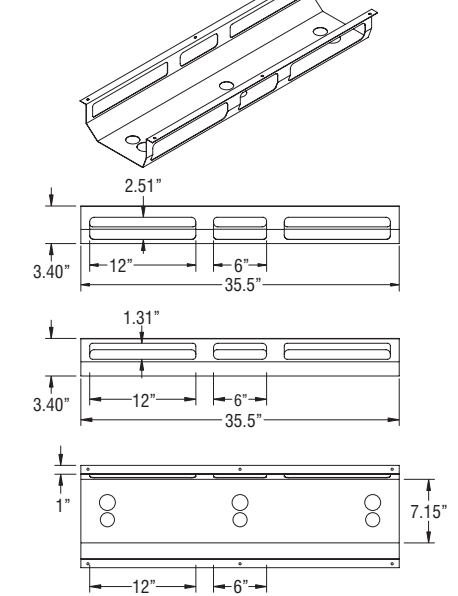

36" Wire Trough

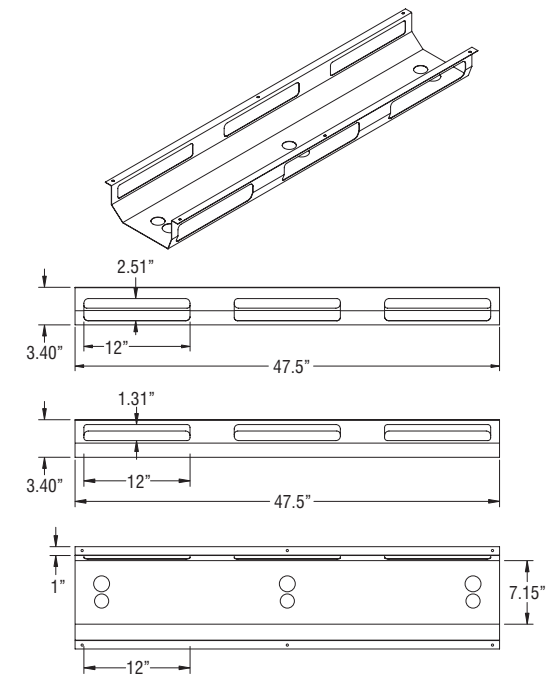

48" Wire Trough



DIMENSIONS - Polyester Felt Modesty Panel

Toggle Rectangular Tables

Reference chart below to specify the polyester felt modesty panel screens for all applicable Toggle Rectangular Table models. The tabletops below will have appropriate pre-drilled holes to accept the polyester felt modesty panel.

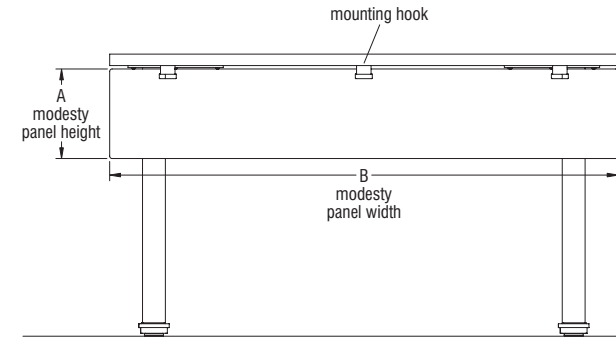

Toggle Rectangular Tables with Polyester Felt Modesty Panel (back view)(30" x 54" Model FX shown)

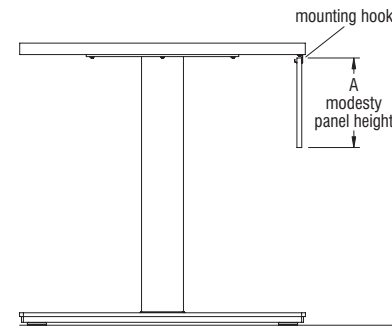

Toggle Rectangular Tables with Polyester Felt Modesty Panel (side view)(30" x 54" Model FX shown)

Polyester Felt Modesty Panel Measurements on Rectangular Tables

Table Dimension	Model Number	A Modesty Panel Height	B Modesty Panel Width	Number of Hooks
24 x 48"	TOGL2448FX	9.25"	46.5"	2
24 x 54"	TOGL2454FX	9.25"	52.5"	3
24 x 60"	TOGL2460FX	9.25"	58.5"	3
24 x 66"	TOGL2466FX	9.25"	64.5"	3
24 x 72"	TOGL2472FX	9.25"	70.5"	3
30 x 48"	TOGL3048FX	9.25"	46.5"	2
30 x 54"	TOGL3054FX	9.25"	52.5"	3
30 x 60"	TOGL3060FX	9.25"	58.5"	3
30 x 66"	TOGL3066FX	9.25"	64.5"	3
30 x 72"	TOGL3072FX	9.25"	70.5"	3
36 x 48"	TOGL3648FX	9.25"	46.5"	2
36 x 54"	TOGL3654FX	9.25"	52.5"	3
36 x 60"	TOGL3660FX	9.25"	58.5"	3
36 x 66"	TOGL3666FX	9.25"	64.5"	3
36 x 72"	TOGL3672FX	9.25"	70.5"	3
24 x 48"	TOGL2448ELC	9.25"	46.5"	2
24 x 54"	TOGL2454ELC	9.25"	52.5"	3
24 x 60"	TOGL2460ELC	9.25"	58.5"	3
24 x 66"	TOGL2466ELC	9.25"	64.5"	3
24 x 72"	TOGL2472ELC	9.25"	70.5"	3
30 x 48"	TOGL3048ELC	9.25"	46.5"	2
30 x 54"	TOGL3054ELC	9.25"	52.5"	3
30 x 60"	TOGL3060ELC	9.25"	58.5"	3
30 x 66"	TOGL3066ELC	9.25"	64.5"	3
30 x 72"	TOGL3072ELC	9.25"	70.5"	3
36 x 48"	TOGL3648ELC	9.25"	46.5"	2
36 x 54"	TOGL3654ELC	9.25"	52.5"	3
36 x 60"	TOGL3660ELC	9.25"	58.5"	3
36 x 66"	TOGL3666ELC	9.25"	64.5"	3
36 x 72"	TOGL3672ELC	9.25"	70.5"	3

DIMENSIONS - Polyester Felt Modesty Panel

Toggle 120° Corner Tables

Reference chart below to specify the polyester felt modesty panel screens for all applicable Toggle 120° Corner Table models. The tabletops below will have appropriate pre-drilled holes to accept the polyester felt modesty panel.

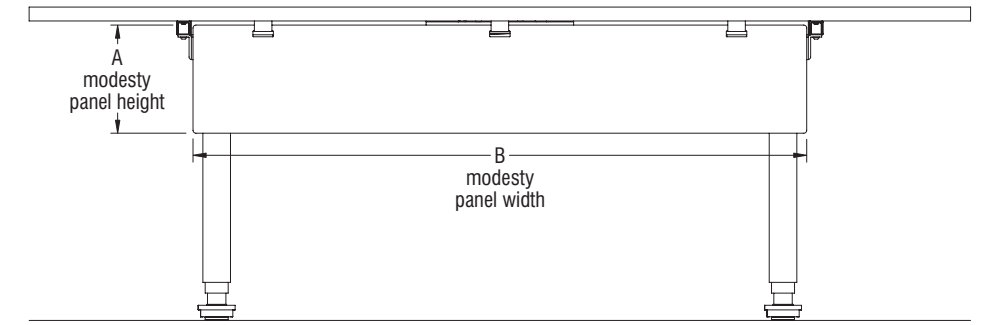

Toggle 120° Corner Tables with Polyester Felt Modesty Panel (back view)(30" x 48" Model EL shown)

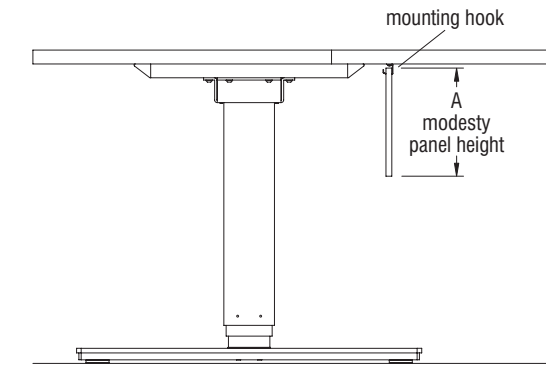

Toggle 120° Corner Tables with Polyester Felt Modesty Panel (side view)(30" x 48" Model EL shown)

Polyester Felt Modesty Panel Measurements on 120° Corner Tables

Table Dimension	Model Number	A Modesty Panel Height	B Modesty Panel Width	Number of Hooks
30 x 48"	TOGLC3048EL	9.25"	52.5"	3
30 x 48"	TOGLC3048ELC	9.25"	52.5"	3



DIMENSIONS - Polyester Felt Modesty Panel

Toggle Square Shoe Tables

Reference chart below to specify the polyester felt modesty panel screens for all applicable Toggle Square Shoe Table models. The tabletops below will have appropriate pre-drilled holes to accept the polyester felt modesty panel.

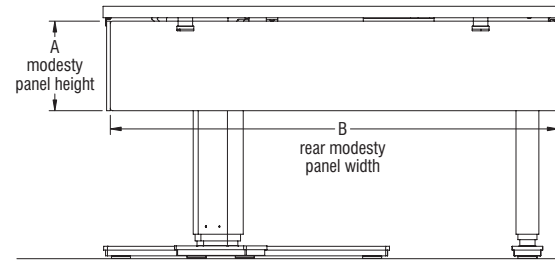

Toggle Square Shoe Tables with Polyester Felt Modesty Panel (back view)(30" x 48" Model EL shown)

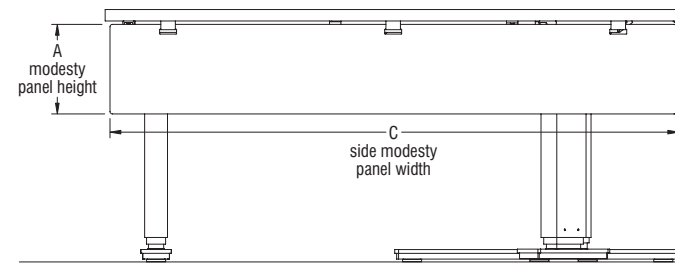

Toggle Square Shoe Tables with Polyester Felt Modesty Panel (side view)(30" x 48" Model EL shown)

Polyester Felt Modesty Panel Measurements on Square Shoe Tables						
Table Dimension	Model Number	A Modesty Panel Height	B Rear Modesty Panel Width	Number of Hooks for Rear Modesty Panel	C Side Modesty Panel Width	Number of Hooks for Side Modesty Panel
24 x 48 x 60"	TOGLSS244860	9.25"	46.5"	2	58.5"	3
24 x 48 x 66"	TOGLSS244866	9.25"	46.5"	2	64.5"	3
24 x 48 x 72"	TOGLSS244872	9.25"	46.5"	2	70.5"	3
24 x 48 x 84"	TOGLSS244884	9.25"	46.5"	2	82.5"	3
24 x 60 x 48"	TOGLSS246048	9.25"	58.5"	3	46.5"	2
24 x 66 x 48"	TOGLSS246648	9.25"	64.5"	3	46.5"	2
24 x 72 x 48"	TOGLSS247248	9.25"	70.5"	3	46.5"	2
24 x 84 x 48"	TOGLSS248448	9.25"	82.5"	3	46.5"	2
30 x 48 x 60"	TOGLSS304860	9.25"	46.5"	2	58.5"	3
30 x 48 x 66"	TOGLSS304866	9.25"	46.5"	2	64.5"	3
30 x 48 x 72"	TOGLSS304872	9.25"	46.5"	2	70.5"	3
30 x 48 x 84"	TOGLSS304884	9.25"	46.5"	2	82.5"	3
30 x 60 x 48"	TOGLSS306048	9.25"	58.5"	3	46.5"	2
30 x 66 x 48"	TOGLSS306648	9.25"	64.5"	3	46.5"	2
30 x 72 x 48"	TOGLSS307248	9.25"	70.5"	3	46.5"	2
30 x 84 x 48"	TOGLSS308448	9.25"	82.5"	3	46.5"	2

STATEMENT OF LINE

Toggle Dual Motor T-Leg Electric-Base Table (Model EL)

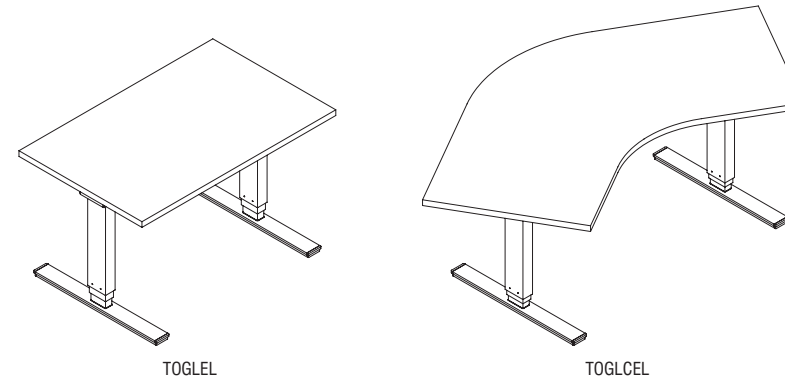

Toggle Dual Motor C-Leg Electric-Base Table (Model ELC)

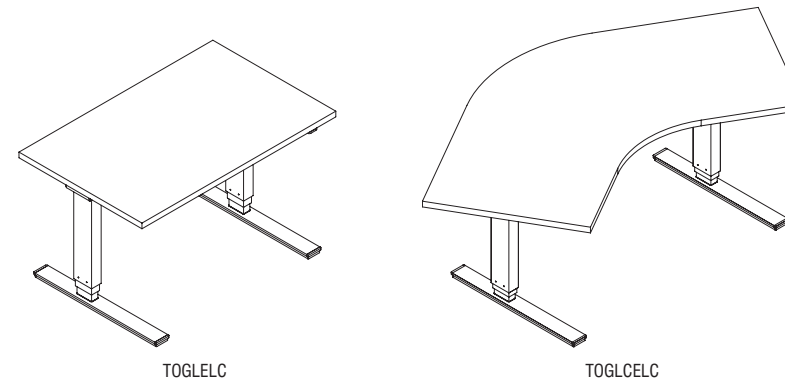

Toggle Fixed-Base Table (Model FX)

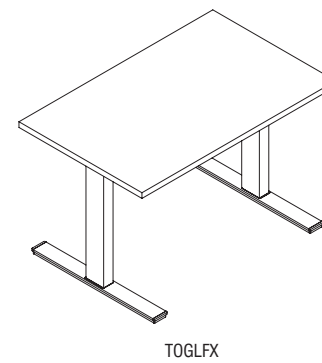

Toggle Triple Motor C-Leg Electric-Base Table (Model SS)

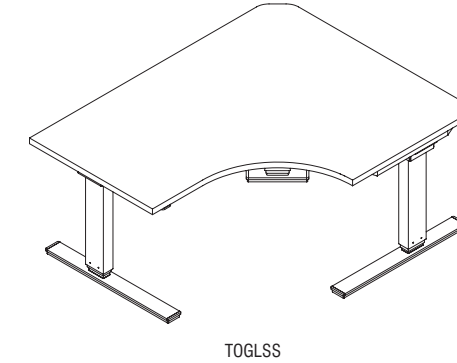



Surface Finish--Grade 1 Standard Laminate

- Beigewood
- Belair
- Biltmore Cherry
- Black
- Brighton Walnut
- Castle Oak
- Cherry Storm
- Classic Linen
- Cocobala
- Crisp Linen
- Designer White
- Dove Grey
- Florence Walnut
- Friston Ash
- Frosty White
- Graphite Nebula
- Grey
- High Rise
- Hollyberry
- Island
- Italian Silver Ash
- Kensington Maple
- Lapis Blue
- Monticello Maple
- North Sea
- Ocean
- Pinnacle Walnut
- River Cherry
- Shadow Zephyr
- Sterling Ash
- Titanium Evolv
- White Nebula
- White Sand
- Windsor Mahogany

Surface Finish--Grade 2 Standard Laminate

- Akira
- Black Alicante
- Black Hills Oak
- Calcutta Marble
- Dering Forest
- Fawn Cypress
- Ice Mist
- Markerboard White
- Valley Forge Elm
- White River Forest

Surface Finish--Grade 3 Standard Laminate

- Black Velvet
- Cumberland Walnut
- Designer White Velvet
- Hartley Walnut
- Nile Velvet
- Raleigh Walnut
- Solano Walnut
- Spruce Velvet

Base and Trough Paint Color

- LBZ Black
- LBQ Silver
- LBT White

Edge Color for 74P Edge

- LBW Akira
- LCO Beigewood
- LCX Belair
- LCI Biltmore Cherry
- LCC Black
- LRI Black Hills Oak
- LDR Blue Grey
- LDG Brighton Walnut
- LFH Castle Oak
- LFW Cayenne
- LGN Cherry Storm
- LGE Cocobala
- LHE Cool Grey
- LHY Cumberland Walnut
- LID Dering Forest
- LIT Designer White
- LKM Everglade Shade
- LLB Fawn Cypress
- LMT Flannel
- LNA Florence Walnut
- LON Friston Ash
- LPW Frosty White
- LRY Hartley Walnut
- LSR Hazy Jade
- LAZ Italian Silver Ash
- LTV Kensington Maple
- LWL Light Tone
- LWN Mardi Gras
- LWY Misty Brown
- LAK Monticello Maple
- LBY Multiplex
- LBH Nemo
- LCQ Nordic
- LDF Pinnacle Walnut
- LFQ Poppy Red
- LIM Rainforest
- LMK Raleigh Walnut
- LVF River Cherry
- LWR Rubber Ducky
- LVB Sand
- LCJ Sky Blue
- LDE Solano Walnut
- LHW Sterling Ash
- LNL Surf's Up
- LRW Tarragon
- LSG Twilight Shadow
- LSC Ultra Blue
- Windsor Mahogany
- Zesty Lime

Edge Color for KN Edge

- BL Beigewood
- SL Belair
- WH Biltmore Cherry
- EAK Black
- EBZ Blue Grey
- EBQ Brighton Walnut
- EBT Castle Oak
- EBL Cayenne
- EBH Cherry Storm
- EGR Cocobala
- EBW Cool Grey
- ECO Designer White
- ECY Everglade Shade
- ECX Flannel
- ECC Florence Walnut
- ECG Friston Ash
- ECJ Frosty White
- EDF Hazy Jade
- EDR Italian Silver Ash
- EEV Kensington Maple
- EFQ Light Tone
- EFN Mardi Gras
- EFC Misty Brown
- EFH Monticello Maple
- EFW Nemo
- EHW Nordic
- EHJ Pinnacle Walnut
- EIT Poppy Red
- EKM Rainforest
- ELG River Cherry
- EMG Rubber Ducky
- EMY Sand
- EMT Sky Blue
- EMB Sterling Ash
- ENE Surf's Up
- END Tarragon
- EPW Twilight Shadow
- EPR Ultra Blue
- ERQ Warm Grey
- ERW Windsor Mahogany
- ERY Zesty Lime
- ERK Polyester Felt Modesty Panel
- ESA Dandelion
- ESK Fawn
- ESG Flannel
- EAZ Heather
- ESP Lava
- ETQ Mallard
- ETI Midnight Blue
- EUB Pepper
- EVF Spring
- EWG Tidal Wave
- EWR
- EWY
- EZL

- EBZ
- EBQ
- EBT
- EBL
- EGR
- EBW
- ECO
- ECY
- ECX
- ECC
- ECG
- EDR
- EEV
- EFN
- EFC
- EFH
- EFW
- EHJ
- EIT
- EKM
- ELG
- EMG
- EMY
- EMT
- ENE
- END
- EPW
- EPR
- ERQ
- ERY
- ERK
- ESA
- ESK
- EAZ
- ESP
- ETQ
- ETI
- EUB
- EWG
- EWY
- EZL
- FTDD
- FTFW
- FTFN
- FTHR
- FTLV
- FTML
- FTMB
- FTPR
- FTSG
- FTTW



Finish Cards

View color swatches for items listed within this document.

- [Paints](#)
- [Wood/Veneer](#)
- [Molded Edges](#)
- [Hard Plastics](#)
- [Plastics/Poly](#)
- [Laminates](#)
- [Edge Styles](#)
- [Glass](#)

Certain options referenced may not be available on GSA Schedule.

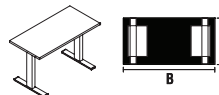
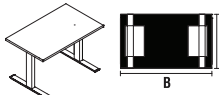

MODEL	A x B	MODEL NUMBER							Approx. Packaged Weight	74P Edge (74P)	Postformed Edge (PL)	Knife Edge (KN)	Laminate Grade 2 add to list price	Laminate Grade 3 add to list price	Felt Modesty Panel add to list price
		Basic Model	Edge Style	Modesty Panel	Edge Color	Surface Finish	Base Finish	Polyester Modesty Panel Color							
 Rectangular Fixed Base Tables - 24"D • 29" High TGFX	23-1/2 x 46-1/2"	TOGL2448FX	<input type="checkbox"/>	<input type="checkbox"/>	<input type="checkbox"/>	<input type="checkbox"/>	85.00#	\$ 720	\$ 750	\$ 773	\$ 19	\$ 120	\$ 192		
	23-1/2 x 52-1/2"	TOGL2454FX	<input type="checkbox"/>	<input type="checkbox"/>	<input type="checkbox"/>	<input type="checkbox"/>	85.00#	758	783	815	27	178	192		
	23-1/2 x 58-1/2"	TOGL2460FX	<input type="checkbox"/>	<input type="checkbox"/>	<input type="checkbox"/>	<input type="checkbox"/>	95.00#	768	797	836	27	178	192		
	23-1/2 x 64-1/2"	TOGL2466FX	<input type="checkbox"/>	<input type="checkbox"/>	<input type="checkbox"/>	<input type="checkbox"/>	95.00#	813	840	905	27	178	192		
	23-1/2 x 70-1/2"	TOGL2472FX	<input type="checkbox"/>	<input type="checkbox"/>	<input type="checkbox"/>	<input type="checkbox"/>	105.00#	824	858	927	27	178	192		
 Rectangular Fixed Base Tables - 30"D • 29" High TGFX	29-1/2 x 46-1/2"	TOGL3048FX	<input type="checkbox"/>	<input type="checkbox"/>	<input type="checkbox"/>	<input type="checkbox"/>	97.00#	\$ 797	\$ 829	\$ 832	\$ 27	\$ 178	\$ 192		
	29-1/2 x 52-1/2"	TOGL3054FX	<input type="checkbox"/>	<input type="checkbox"/>	<input type="checkbox"/>	<input type="checkbox"/>	97.00#	873	912	961	27	178	192		
	29-1/2 x 58-1/2"	TOGL3060FX	<input type="checkbox"/>	<input type="checkbox"/>	<input type="checkbox"/>	<input type="checkbox"/>	109.00#	888	924	973	27	178	192		
	29-1/2 x 64-1/2"	TOGL3066FX	<input type="checkbox"/>	<input type="checkbox"/>	<input type="checkbox"/>	<input type="checkbox"/>	109.00#	936	974	1063	27	178	192		
	29-1/2 x 70-1/2"	TOGL3072FX	<input type="checkbox"/>	<input type="checkbox"/>	<input type="checkbox"/>	<input type="checkbox"/>	121.00#	949	988	1079	27	178	192		
 Rectangular Fixed Base Tables - 36"D • 29" High TGFX	35-1/2 x 46-1/2"	TOGL3648FX	<input type="checkbox"/>	<input type="checkbox"/>	<input type="checkbox"/>	<input type="checkbox"/>	104.00#	\$ 836	\$ 868	\$ 941	\$ 37	\$ 235	\$ 192		
	35-1/2 x 52-1/2"	TOGL3654FX	<input type="checkbox"/>	<input type="checkbox"/>	<input type="checkbox"/>	<input type="checkbox"/>	104.00#	917	956	1044	53	368	192		
	35-1/2 x 58-1/2"	TOGL3660FX	<input type="checkbox"/>	<input type="checkbox"/>	<input type="checkbox"/>	<input type="checkbox"/>	121.00#	933	970	1060	53	368	192		
	35-1/2 x 64-1/2"	TOGL3666FX	<input type="checkbox"/>	<input type="checkbox"/>	<input type="checkbox"/>	<input type="checkbox"/>	121.00#	956	993	1376	53	368	192		
	35-1/2 x 70-1/2"	TOGL3672FX	<input type="checkbox"/>	<input type="checkbox"/>	<input type="checkbox"/>	<input type="checkbox"/>	136.00#	965	1003	1390	53	368	192		

A **B** **C** **D** **E** **F** **G**

HOW TO ORDER

- Indicate the following information on order form:
- Quantity of each item.
 - Model number, including options. See "How To Build a Model Number".
 - Any special service required.

Note: • The indicates that a choice is required.
 • The absence of the indicates that no choice is required.
 • Alpha-numeric characters in place of indicate that no other alternatives are available.

HOW TO BUILD A MODEL NUMBER

- A** Select basic model.
- B** Select edge style.
 74P - 74P edge
 PL - Postformed edge
 KN - Knife edge
 Knife edge (KN) and Postformed edge (PL) on user side only
- C** Select modesty panel.
 NMP - No modesty panel
 PMP - Polyester felt modesty panel
- D** Select edge color.
 Refer to the **Product Color Options** page in this price list.
 Edge color offerings are based on edge style selections.
- E** Select surface finish.
 Refer to the **Product Color Options** page in this price list.
 Surface finish offerings are based on edge style selections.
- F** Select base finish.
 Refer to the **Product Color Options** page in this price list.
- G** Select modesty panel color (only if polyester felt panel is chosen).
 Refer to the **Product Color Options** page in this price list.

SPECIAL SERVICES



Special Carton Marking

With specially marked information N/C

Shipping
 Ships **knocked down, FOB Bonduel, WI 54107, freight prepaid.** Freight class 125.

Specifications and prices are subject to change without prior notice.



MODEL	A x B x C	MODEL NUMBER							Approx. Packaged Weight	74P Edge (74P)	Postformed Edge (PL)	Knife Edge (KN)	Laminate Grade 2 add to list price	Laminate Grade 3 add to list price	Felt Modesty Panel add to list price
		Basic Model	Edge Style	Modesty Panel	Edge Color	Surface Finish	Base Finish	Polyester Modesty Panel Color							
 TGEL Rectangular Dual Motor Electric Base Tables - 24" D <ul style="list-style-type: none"> • 26-52" Electrically adjustable • Simple up/down switch • Maximum operating load varies (see chart below) • 3-Stage base 	23-1/2 x 46-1/2"	TOGL2448EL	<input type="checkbox"/>	<input type="checkbox"/>	<input type="checkbox"/>	<input type="checkbox"/>	<input type="checkbox"/>	<input type="checkbox"/>	131.00#	\$ 2223	\$ 2270	\$ 2313	\$ 19	\$ 120	\$ 192
	23-1/2 x 52-1/2"	TOGL2454EL	<input type="checkbox"/>	<input type="checkbox"/>	<input type="checkbox"/>	<input type="checkbox"/>	<input type="checkbox"/>	<input type="checkbox"/>	131.00#	2261	2323	2349	27	178	192
	23-1/2 x 58-1/2"	TOGL2460EL	<input type="checkbox"/>	<input type="checkbox"/>	<input type="checkbox"/>	<input type="checkbox"/>	<input type="checkbox"/>	<input type="checkbox"/>	141.00#	2276	2339	2365	27	178	192
	23-1/2 x 64-1/2"	TOGL2466EL	<input type="checkbox"/>	<input type="checkbox"/>	<input type="checkbox"/>	<input type="checkbox"/>	<input type="checkbox"/>	<input type="checkbox"/>	141.00#	2331	2420	2425	27	178	192
	23-1/2 x 70-1/2"	TOGL2472EL	<input type="checkbox"/>	<input type="checkbox"/>	<input type="checkbox"/>	<input type="checkbox"/>	<input type="checkbox"/>	<input type="checkbox"/>	151.00#	2342	2433	2435	27	178	192
 TGEL Rectangular Dual Motor Electric Base Tables - 30" D <ul style="list-style-type: none"> • 26-52" Electrically adjustable • Simple up/down switch • Maximum operating load varies (see chart below) • 3-Stage base 	29-1/2 x 46-1/2"	TOGL3048EL	<input type="checkbox"/>	<input type="checkbox"/>	<input type="checkbox"/>	<input type="checkbox"/>	<input type="checkbox"/>	<input type="checkbox"/>	143.00#	\$ 2320	\$ 2380	\$ 2415	\$ 27	\$ 178	\$ 192
	29-1/2 x 52-1/2"	TOGL3054EL	<input type="checkbox"/>	<input type="checkbox"/>	<input type="checkbox"/>	<input type="checkbox"/>	<input type="checkbox"/>	<input type="checkbox"/>	143.00#	2394	2470	2490	27	178	192
	29-1/2 x 58-1/2"	TOGL3060EL	<input type="checkbox"/>	<input type="checkbox"/>	<input type="checkbox"/>	<input type="checkbox"/>	<input type="checkbox"/>	<input type="checkbox"/>	155.00#	2411	2487	2506	27	178	192
	29-1/2 x 64-1/2"	TOGL3066EL	<input type="checkbox"/>	<input type="checkbox"/>	<input type="checkbox"/>	<input type="checkbox"/>	<input type="checkbox"/>	<input type="checkbox"/>	155.00#	2464	2565	2578	27	178	192
	29-1/2 x 70-1/2"	TOGL3072EL	<input type="checkbox"/>	<input type="checkbox"/>	<input type="checkbox"/>	<input type="checkbox"/>	<input type="checkbox"/>	<input type="checkbox"/>	168.00#	2478	2578	2590	27	178	192
 TGEL Rectangular Dual Motor Electric Base Tables - 36" D <ul style="list-style-type: none"> • 26-52" Electrically adjustable • Simple up/down switch • Maximum operating load varies (see chart below) • 3-Stage base 	35-1/2 x 46-1/2"	TOGL3648EL	<input type="checkbox"/>	<input type="checkbox"/>	<input type="checkbox"/>	<input type="checkbox"/>	<input type="checkbox"/>	<input type="checkbox"/>	151.00#	\$ 2354	\$ 2447	\$ 2450	\$ 37	\$ 235	\$ 192
	35-1/2 x 52-1/2"	TOGL3654EL	<input type="checkbox"/>	<input type="checkbox"/>	<input type="checkbox"/>	<input type="checkbox"/>	<input type="checkbox"/>	<input type="checkbox"/>	151.00#	2439	2528	2547	53	368	192
	35-1/2 x 58-1/2"	TOGL3660EL	<input type="checkbox"/>	<input type="checkbox"/>	<input type="checkbox"/>	<input type="checkbox"/>	<input type="checkbox"/>	<input type="checkbox"/>	168.00#	2450	2547	2560	53	368	192
	35-1/2 x 64-1/2"	TOGL3666EL	<input type="checkbox"/>	<input type="checkbox"/>	<input type="checkbox"/>	<input type="checkbox"/>	<input type="checkbox"/>	<input type="checkbox"/>	168.00#	2470	2570	2846	53	368	192
	35-1/2 x 70-1/2"	TOGL3672EL	<input type="checkbox"/>	<input type="checkbox"/>	<input type="checkbox"/>	<input type="checkbox"/>	<input type="checkbox"/>	<input type="checkbox"/>	182.00#	2484	2583	2857	53	368	192

A **B** **C** **D** **E** **F** **G**

HOW TO ORDER

- Indicate the following information on order form:
1. Quantity of each item.
 2. Model number, including options. See "How To Build a Model Number".
 3. Any special service required.

Note: • The indicates that a choice is required.
 • The absence of the indicates that no choice is required.
 • Alpha-numeric characters in place of indicate that no other alternatives are available.

HOW TO BUILD A MODEL NUMBER

- A** Select basic model.
- B** Select edge style.
 - 74P** - 74P edge
 - PL** - Postformed edge
 - KN** - Knife edge
 Knife edge (KN) and Postformed edge (PL) on user side only
- C** Select modesty panel.
 - NMP** - No modesty panel
 - PMP** - Polyester felt modesty panel
- D** Select edge color.

Refer to the **Product Color Options** page in this price list.
 Edge color offerings are based on edge style selections.
- E** Select surface finish.

Refer to the **Product Color Options** page in this price list.
 Surface finish offerings are based on edge style selections.
- F** Select base finish.

Refer to the **Product Color Options** page in this price list.
- G** Select modesty panel color (only if polyester felt panel is chosen).

Refer to the **Product Color Options** page in this price list.

INFORMATION

MAXIMUM OPERATING LOAD

Model Size	Maximum Operating Load
2448EL/C	220 Pounds
2460EL/C	210 Pounds
2472EL/C	200 Pounds
3048EL/C	210 Pounds
3060EL/C	200 Pounds
3072EL/C	185 Pounds
3648EL/C	200 Pounds
3660EL/C	185 Pounds
3672EL/C	170 Pounds
3048EL/C (corner)	180 Pounds

SPECIAL SERVICES

Special Carton Marking

With specially marked information N/C

Shipping
 Ships **knocked down, FOB Bonduel, WI 54107, freight prepaid.** Freight class 125.

Specifications and prices are subject to change without prior notice.



MODEL	A x B x C	MODEL NUMBER							Approx. Packaged Weight	74P Edge (74P)	Postformed Edge (PL)	Knife Edge (KN)	Laminate Grade 2 add to list price	Laminate Grade 3 add to list price	Felt Modesty Panel add to list price
		Basic Model	Edge Style	Modesty Panel	Edge Color	Surface Finish	Base Finish	Polyester Modesty Panel Color							
<p>Rectangular Dual Motor Electric Base Tables - 24" D</p> <ul style="list-style-type: none"> • 26-52" Electrically adjustable • Simple up/down switch • Maximum operating load varies (see chart below) • 3-Stage base 	23-1/2 x 46-1/2"	TOGL2448ELC	□□□	□□□	□□□	□□□	□□	□□□□	131.00#	\$ 2223	\$ 2270	\$ 2313	\$ 19	\$ 120	\$ 192
	23-1/2 x 52-1/2"	TOGL2454ELC	□□□	□□□	□□□	□□□	□□	□□□□	131.00#	2261	2323	2349	27	178	192
	23-1/2 x 58-1/2"	TOGL2460ELC	□□□	□□□	□□□	□□□	□□	□□□□	141.00#	2276	2339	2365	27	178	192
	23-1/2 x 64-1/2"	TOGL2466ELC	□□□	□□□	□□□	□□□	□□	□□□□	141.00#	2331	2420	2425	27	178	192
	23-1/2 x 70-1/2"	TOGL2472ELC	□□□	□□□	□□□	□□□	□□	□□□□	151.00#	2342	2433	2435	27	178	192
<p>Rectangular Dual Motor Electric Base Tables - 30" D</p> <ul style="list-style-type: none"> • 26-52" Electrically adjustable • Simple up/down switch • Maximum operating load varies (see chart below) • 3-Stage base 	29-1/2 x 46-1/2"	TOGL3048ELC	□□□	□□□	□□□	□□□	□□	□□□□	143.00#	\$ 2320	\$ 2380	\$ 2415	\$ 27	\$ 178	\$ 192
	29-1/2 x 52-1/2"	TOGL3054ELC	□□□	□□□	□□□	□□□	□□	□□□□	143.00#	2400	2470	2495	27	178	192
	29-1/2 x 58-1/2"	TOGL3060ELC	□□□	□□□	□□□	□□□	□□	□□□□	155.00#	2411	2487	2506	27	178	192
	29-1/2 x 64-1/2"	TOGL3066ELC	□□□	□□□	□□□	□□□	□□	□□□□	155.00#	2464	2565	2578	27	178	192
	29-1/2 x 70-1/2"	TOGL3072ELC	□□□	□□□	□□□	□□□	□□	□□□□	168.00#	2478	2578	2590	27	178	192
<p>Rectangular Dual Motor Electric Base Tables - 36" D</p> <ul style="list-style-type: none"> • 26-52" Electrically adjustable • Simple up/down switch • Maximum operating load varies (see chart below) • 3-Stage base 	35-1/2 x 46-1/2"	TOGL3648ELC	□□□	□□□	□□□	□□□	□□	□□□□	151.00#	\$ 2354	\$ 2447	\$ 2450	\$ 37	\$ 235	\$ 192
	35-1/2 x 52-1/2"	TOGL3654ELC	□□□	□□□	□□□	□□□	□□	□□□□	151.00#	2439	2532	2547	53	368	192
	35-1/2 x 58-1/2"	TOGL3660ELC	□□□	□□□	□□□	□□□	□□	□□□□	168.00#	2450	2547	2560	53	368	192
	35-1/2 x 64-1/2"	TOGL3666ELC	□□□	□□□	□□□	□□□	□□	□□□□	168.00#	2470	2570	2846	53	368	192
	35-1/2 x 70-1/2"	TOGL3672ELC	□□□	□□□	□□□	□□□	□□	□□□□	182.00#	2484	2583	2857	53	368	192

A **B** **C** **D** **E** **F** **G**

HOW TO ORDER

- Indicate the following information on order form:
- Quantity of each item.
 - Model number, including options. See "How To Build a Model Number".
 - Any special service required.

Note: • The □ indicates that a choice is required.
 • The absence of the □ indicates that no choice is required.
 • Alpha-numeric characters in place of □ indicate that no other alternatives are available.

HOW TO BUILD A MODEL NUMBER

- A** Select basic model.
- B** Select edge style.
 74P - 74P edge
 PL - Postformed edge
 KN - Knife edge
 Knife edge (KN) and Postformed edge (PL) on user side only
- C** Select modesty panel.
 NMP - No modesty panel
 PMP - Polyester felt modesty panel
- D** Select edge color.
 Refer to the **Product Color Options** page in this price list.
 Edge color offerings are based on edge style selections.
- E** Select surface finish.
 Refer to the **Product Color Options** page in this price list.
 Surface finish offerings are based on edge style selections.
- F** Select base finish.
 Refer to the **Product Color Options** page in this price list.
- G** Select modesty panel color (only if polyester felt panel is chosen).
 Refer to the **Product Color Options** page in this price list.

INFORMATION

MAXIMUM OPERATING LOAD

Model Size	Maximum Operating Load
2448EL/C	220 Pounds
2460EL/C	210 Pounds
2472EL/C	200 Pounds
3048EL/C	210 Pounds
3060EL/C	200 Pounds
3072EL/C	185 Pounds
3648EL/C	200 Pounds
3660EL/C	185 Pounds
3672EL/C	170 Pounds
3048EL/C (corner)	180 Pounds

SPECIAL SERVICES

Special Carton Marking

With specially marked information N/C

Shipping
 Ships **knocked down, FOB Bonduel, WI 54107, freight prepaid.** Freight class 125.

Specifications and prices are subject to change without prior notice.

Toggle® Square Shoe Tables

Triple Motor Electric Base



Toggle® Square Shoe Tables

Triple Motor Electric Base

MODEL	A x B x C	MODEL NUMBER							Approx. Packaged Weight	74P Edge (74P)	Knife Edge (KN)	Laminate Grade 2 add to list price	Laminate Grade 3 add to list price	Felt Modesty Panel add to list price
		Basic Model	Edge Style	Modesty Panel	Edge Color	Surface Finish	Base Finish	Polyester Modesty Panel Color						
<p>Square Shoe Triple Motor Electric Base Tables (Left) - 24\"D</p> <ul style="list-style-type: none"> • 26-52\" Electrically adjustable • Simple up/down switch • Maximum operating load varies (see chart below) • 3-Stage base • Includes two modesty panel appropriately sized for each non-user side of the table when specified 	24 x 60 x 48\"	TOGLSS246048	<input type="checkbox"/>	<input type="checkbox"/>	<input type="checkbox"/>	192.00#	\$ 2736	\$ 2826	\$ 53	\$ 368	\$ 382			
	24 x 66 x 48\"	TOGLSS246648	<input type="checkbox"/>	<input type="checkbox"/>	<input type="checkbox"/>	197.00#	2826	2927	53	368	382			
	24 x 72 x 48\"	TOGLSS247248	<input type="checkbox"/>	<input type="checkbox"/>	<input type="checkbox"/>	202.00#	2863	2991	53	368	382			
	24 x 84 x 48\"	TOGLSS248448	<input type="checkbox"/>	<input type="checkbox"/>	<input type="checkbox"/>	211.00#	3220	3372	74	473	382			
<p>Square Shoe Triple Motor Electric Base Tables (Right) - 24\"D</p> <ul style="list-style-type: none"> • 26-52\" Electrically adjustable • Simple up/down switch • Maximum operating load varies (see chart below) • 3-Stage base • Includes two modesty panel appropriately sized for each non-user side of the table when specified 	24 x 48 x 60\"	TOGLSS244860	<input type="checkbox"/>	<input type="checkbox"/>	<input type="checkbox"/>	192.00#	\$ 2736	\$ 2826	\$ 53	\$ 368	\$ 382			
	24 x 48 x 66\"	TOGLSS244866	<input type="checkbox"/>	<input type="checkbox"/>	<input type="checkbox"/>	197.00#	2826	2927	53	368	382			
	24 x 48 x 72\"	TOGLSS244872	<input type="checkbox"/>	<input type="checkbox"/>	<input type="checkbox"/>	202.00#	2863	2991	53	368	382			
	24 x 48 x 84\"	TOGLSS244884	<input type="checkbox"/>	<input type="checkbox"/>	<input type="checkbox"/>	211.00#	3220	3372	74	473	382			
<p>Square Shoe Triple Motor Electric Base Tables (Left) - 30\"D</p> <ul style="list-style-type: none"> • 26-52\" Electrically adjustable • Simple up/down switch • Maximum operating load varies (see chart below) • 3-Stage base • Includes two modesty panel appropriately sized for each non-user side of the table when specified 	30 x 60 x 48\"	TOGLSS306048	<input type="checkbox"/>	<input type="checkbox"/>	<input type="checkbox"/>	203.00#	\$ 2762	\$ 2852	\$ 53	\$ 368	\$ 382			
	30 x 66 x 48\"	TOGLSS306648	<input type="checkbox"/>	<input type="checkbox"/>	<input type="checkbox"/>	209.00#	2852	2952	53	368	382			
	30 x 72 x 48\"	TOGLSS307248	<input type="checkbox"/>	<input type="checkbox"/>	<input type="checkbox"/>	215.00#	2889	3016	53	368	382			
	30 x 84 x 48\"	TOGLSS308448	<input type="checkbox"/>	<input type="checkbox"/>	<input type="checkbox"/>	227.00#	3245	3397	74	473	382			
<p>Square Shoe Triple Motor Electric Base Tables (Right) - 30\"D</p> <ul style="list-style-type: none"> • 26-52\" Electrically adjustable • Simple up/down switch • Maximum operating load varies (see chart below) • 3-Stage base • Includes two modesty panel appropriately sized for each non-user side of the table when specified 	30 x 48 x 60\"	TOGLSS304860	<input type="checkbox"/>	<input type="checkbox"/>	<input type="checkbox"/>	203.00#	\$ 2762	\$ 2852	\$ 53	\$ 368	\$ 382			
	30 x 48 x 66\"	TOGLSS304866	<input type="checkbox"/>	<input type="checkbox"/>	<input type="checkbox"/>	209.00#	2852	2952	53	368	382			
	30 x 48 x 72\"	TOGLSS304872	<input type="checkbox"/>	<input type="checkbox"/>	<input type="checkbox"/>	215.00#	2889	3016	53	368	382			
	30 x 48 x 84\"	TOGLSS304884	<input type="checkbox"/>	<input type="checkbox"/>	<input type="checkbox"/>	227.00#	3245	3397	74	473	382			

A **B** **C** **D** **E** **F** **G**

HOW TO ORDER

- Indicate the following information on order form:
- Quantity of each item.
 - Model number, including options. See "How To Build a Model Number".
 - Any special service required.

Note: • The indicates that a choice is required.

- The absence of the indicates that no choice is required.
- Alpha-numeric characters in place of indicate that no other alternatives are available.

HOW TO BUILD A MODEL NUMBER

- A** Select basic model.
- B** Select edge style.
74P - 74P edge
KN - Knife edge
 Knife edge (KN) on user side only
- C** Select modesty panel.
NMP - No modesty panel
PMP - Polyester felt modesty panel

- D** Select edge color.
 Refer to the **Product Color Options** page in this price list.
 Edge color offerings are based on edge style selections.

- E** Select surface finish.
 Refer to the **Product Color Options** page in this price list.
 Surface finish offerings are based on edge style selections.

- F** Select base finish.
 Refer to the **Product Color Options** page in this price list.

- G** Select modesty panel color (only if polyester felt panel is chosen).
 Refer to the **Product Color Options** page in this price list.

INFORMATION

MAXIMUM OPERATING LOAD

Model Size	Maximum Operating Load
246048	260 Pounds
246648	255 Pounds
247248	250 Pounds
248448	240 Pounds
244860	260 Pound
244866	255 Pounds
244872	250 Pounds
244884	240 Pounds
306048	250 Pounds
306648	245 Pounds
307248	235 Pounds
308448	225 Pounds
304860	250 Pound
304866	245 Pounds
304872	235 Pounds
304884	225 Pounds
TGBO.3EL.24	330 Pounds
TGBO.3EL.30	330 Pounds

SPECIAL SERVICES

Special Carton Marking

With specially marked information N/C

Shipping
 Ships **knocked down, FOB Bonduel, WI 54107, freight prepaid.** Freight class 125.

Specifications and prices are subject to change without prior notice.

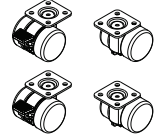
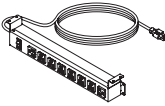
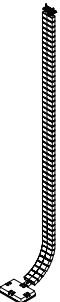

MODEL	MODEL NUMBER		Approx. Packaged Weight	Delivered Pricing
	Basic Model			
 Deluxe Switch with Presets • Includes digital display and 4 preset button • Must be ordered separately	47.2328.HNDDX		1.00#	\$ 123
TGA03				
 Caster Kit - 2-Leg Table • Includes mounting plates and 16 thread cutting screws to mount on the underside of the feet • 2 locking and 2 non-locking black casters • Must be ordered separately	TGCA		1.00#	\$ 80
TGA02				
 Undermount R8 Module • Silver in color • Includes 8-15A, 120 VAC receptacles, 2 outer most rotated 90 degrees to accommodate large plugs • 144" power cord • Under table mount attaches with 4 screws (included) • Module hangs down from surface 1" to allow easier access to plug in/unplug • Includes 4 wire management clips • ETL listed for US and Canada • Dimensions are 16.3" x 2.3" x 2.8"	14.1450.SLVR		3.00#	\$ 319
AC434				
 Vertical Cable Manager • Silver in color • Multi-directional manager holds wires in static and adjustable tables • Weighted base keeps manager in position • Includes magnetic link to easily attach to table leg • Attaches to underside of table with or without wire management trough • Includes 63 links, 1-3 link magnetic piece, 1 top connector, 2 screws, 1 base plate	47.2320.SLVR		1.00#	\$ 118
AC403				

A

HOW TO ORDER

- Indicate the following information on order form:
- Quantity of each item.
 - Model number, including options. See "How To Build a Model Number".
 - Any special service required.

Note:

- The indicates that a choice is required.
- The absence of the indicates that no choice is required.
- Alpha-numeric characters in place of indicate that no other alternatives are available.

HOW TO BUILD A MODEL NUMBER

- A** Select basic model.

SPECIAL SERVICES

Special Carton Marking

With specially marked information N/C

Shipping

Ships **knocked down, FOB Bonduel, WI 54107, freight prepaid.** Freight class 125.

Specifications and prices are subject to change without prior notice.

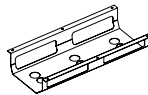
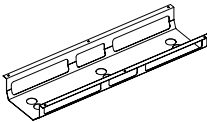
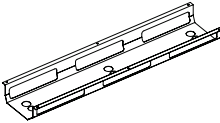

	MODEL	L	MODEL NUMBER		Approx. Packaged Weight	Delivered Pricing
			Basic Model	Paint Color		
 TGA01	Wire Trough • Keeps wires enclosed and tidy • Open design makes it easy to feed cables through trough • Steel construction • Intended for installation into pre-drilled pilot holes • Mounting hardware included • 9-1/2" wide x 4-1/4" high x 24" long • One kit for 48" rectangle or 48" side of square shoe tables	24"	TG.TROUGH.48	<input type="checkbox"/>	5.00#	\$ 97
 TGA01	Wire Trough • Keeps wires enclosed and tidy • Open design makes it easy to feed cables through trough • Steel construction • Intended for installation into pre-drilled pilot holes • Mounting hardware included • 9-1/2" wide x 4-1/4" high x 36" long • One kit for 60" rectangle and corner or 60-66" side of square shoe tables	36"	TG.TROUGH.60	<input type="checkbox"/>	7.00#	\$ 118
 TGA01	Wire Trough • Keeps wires enclosed and tidy • Open design makes it easy to feed cables through trough • Steel construction • Intended for installation into pre-drilled pilot holes • Mounting hardware included • 9-1/2" wide x 4-1/4" high x 48" long • One kit for 72" rectangle or 72-84" side of square shoe tables	48"	TG.TROUGH.72	<input type="checkbox"/>	10.00#	\$ 138

A

B

HOW TO ORDER

- Indicate the following information on order form:
- Quantity of each item.
 - Model number, including options. See "How To Build a Model Number".
 - Any special service required.

Note: • The indicates that a choice is required.
 • The absence of the indicates that no choice is required.
 • Alpha-numeric characters in place of indicate that no other alternatives are available.

HOW TO BUILD A MODEL NUMBER

- A** Select basic model.
B Select paint color.
 Refer to the **Product Color Options** page in this price list.

SPECIAL SERVICES

Special Carton Marking

With specially marked information N/C

Shipping

Ships **knocked down, FOB Bonduel, WI 54107, freight prepaid.** Freight class 125.

Specifications and prices are subject to change without prior notice.



TECHNICAL SPECIFICATIONS

WorkUp Crank-Base (Model CR)

General

The table consists of two adjustable height T-bases (centered column on a horizontal foot) attached to a worksurface support that spans the two bases and supports a worksurface. The top of the worksurface will adjust between 27.11" and 44.83" from the floor by means of a front crank that can be located at either end of the table. A 3/4" diameter steel connecting rod spans from column to column to enable simultaneous adjustment of both columns.

Base

The base consists of a column assembly and foot, both finished with baked on 30 sheen powder-coat paint. The column assembly consists of an outer member and an inner member. The outer member is 2 3/4" square, 14-gauge steel tubing with a 1/4" steel plate welded on the bottom end. The inner member is 2 1/2" square, 14-gauge steel tubing with a 1/4" steel plate welded on the top end. The foot is made of two formed and welded 11-gauge steel components and is attached to the column with 8mm bolts. Two 1 1/2" diameter nylon base leveling glides are threaded into the foot. The base adjusts at a rate of 6 1/3 turns per inch.

Worksurface Support

The worksurface support is formed 11-gauge steel support members with 1/4" steel attachment plates. The worksurface support is attached to the column with 8mm bolts.

Worksurface

Worksurfaces are constructed of 1 1/8" thick 45 lb. density particle board core. The top surface is covered with high-pressure laminate and the bottom surface is covered with a phenolic backing sheet. The perimeter is finished using high impact plastic edging. The worksurface is pre-drilled and attached to the bases using sixteen #12 x 1" tapping screws.

Wire Trough

The wire trough is an optional accessory which must be ordered separately. Constructed of 18-gauge steel with a powder-coated finish which may be coordinated to match the color of table legs. Screws are provided for attachment to the underside of the tabletop, and tops are pre-drilled for wire trough locations. Provides six access holes to feed wires or install cable management systems.

WorkUp Fixed-Base (Model FX)

General

The table consists of two T-bases (centered column on a horizontal foot) supporting a worksurface. The top of the worksurface will be 29" from the floor. See pages 8 & 9 for top sizes.

Base

The base consists of a top plate, welded to a column and a foot, all finished with baked on 30 sheen powder-coat paint. The top plate is 1/4" thick steel. The column is 2 1/2" square, 14-gauge steel tubing with a 1/4" steel plate welded on the bottom end. The foot is made of two formed and welded 11-gauge steel components. The top plate and foot is attached to the column with 8mm bolts. Two 1 1/2" diameter nylon base leveling glides are threaded into the foot.

Worksurface

Worksurfaces are constructed of 1 1/8" thick 45 lb. density particle board core. The top surface is covered with high-pressure laminate and the bottom surface is covered with a phenolic backing sheet. The perimeter is finished using high impact plastic edging. The worksurface is pre-drilled and attached to the bases using sixteen #12 x 1" tapping screws.

Wire Trough

The wire trough is an optional accessory which must be ordered separately. Constructed of 18-gauge steel with a powder-coated finish which may be coordinated to match the color of table legs. Screws are provided for attachment to the underside of the tabletop, and tops are pre-drilled for wire trough locations. Provides six access holes to feed wires or install cable management systems.

WorkUp ANSI/HFES Electric-Base (Model HF)

General

The table consists of two adjustable height T-bases (centered column on a horizontal foot) attached to a worksurface support that spans the two bases and supports a worksurface. The top of the worksurface will adjust between 22.35" and 48.33" from the floor by means of electric controls that can be located at either end of the table. The leg moves up or down at a speed of 50mm/sec (2"/sec). Maximum amps per table is 4 amps.

Base

The base consists of a column assembly and foot, both finished with baked on 30 sheen powder-coat paint. The column assembly consists of an outer member, an intermediate member and an inner member. The outer member is 2 3/4" square, 14-gauge steel tubing with a 1/4" steel plate welded on the bottom end. The intermediate member is 2 1/2" square, 14-gauge steel tubing. The inner member is 2 1/4" square, 14-gauge steel tubing with a 1/4" steel plate welded on the top end. The foot consists of two formed and welded 11-gauge steel components and is attached to the column with 8mm bolts. Two 1 1/2" diameter nylon base leveling glides are threaded into the foot.

Worksurface Support

The worksurface support is formed 11-gauge steel support members with 1/4" steel attachment plates. The worksurface support is attached to the column with 8mm bolts.

Worksurface

Worksurfaces are constructed of 1 1/8" thick 45 lb. density particle board core. The top surface is covered with high-pressure laminate and the bottom surface is covered with a phenolic backing sheet. The perimeter is finished using high impact plastic edging. The worksurface is pre-drilled and attached to the bases using sixteen #12 x 1" tapping screws.

Wire Trough

The wire trough is an optional accessory which must be ordered separately. Constructed of 18-gauge steel with a powder-coated finish which may be coordinated to match the color of table legs. Screws are provided for attachment to the underside of the tabletop, and tops are pre-drilled for wire trough locations. Provides six access holes to feed wires or install cable management systems.

WorkUp Ratchet-Base (Model RT)

General

The table consists of two adjustable height T-bases (centered column on a horizontal foot) attached to a worksurface support that spans the two bases and supports a worksurface. The top of the worksurface adjusts to thirteen positions between 27.11" and 36.56" from the floor by manually lifting the worksurface.

Base

The base consists of a column assembly and foot, both finished with baked on 30 sheen powder-coat paint. The column assembly consists of an outer member and an inner member. The outer member is 2 3/4" square, 14-gauge steel tubing with a 1/4" steel plate welded on the bottom end. The inner member is 2 1/2" square, 14-gauge steel tubing with a 1/4" steel plate welded on the top end. The foot consists of two formed and welded 11-gauge steel components and is attached to the column with 8mm bolts. Two 1 1/2" diameter nylon base leveling glides are threaded into the foot.

Worksurface Support

The worksurface support is formed 11-gauge steel support members with 1/4" steel attachment plates. The worksurface support is attached to the column with 8mm bolts.

Worksurface

Worksurfaces are constructed of 1 1/8" thick 45 lb. density particle board core. The top surface is covered with high-pressure laminate and the bottom surface is covered with a phenolic backing sheet. The perimeter is finished using high impact plastic edging. The worksurface is pre-drilled and attached to the bases using sixteen #12 x 1" tapping screws.

Wire Trough

The wire trough is an optional accessory which must be ordered separately. Constructed of 18-gauge steel with a powder-coated finish which may be coordinated to match the color of table legs. Screws are provided for attachment to the underside of the tabletop, and tops are pre-drilled for wire trough locations. Provides six access holes to feed wires or install cable management systems.

WorkUp Counterbalance-Base (Model CB)

General

The table consists of two adjustable height T-bases (centered column on a horizontal foot) attached to a worksurface support that spans the two bases and supports a worksurface. The top of the worksurface will adjust between 28 1/4" and 46 3/4" from the floor by activating a release lever and manually lifting or lowering the worksurface. The worksurface weight is counterbalanced by pneumatic springs to minimize the manual force required to move the worksurface. The two bases are synchronized with steel bands to maintain a level worksurface. The column uses a roller bearing system to minimize friction in the column.

Base

The base consists of a column assembly and foot finished with baked-on 30 sheen powder-coat paint. The column assembly consists of an outer member and an inner member. The outer member is 2 3/4" square, 14-gauge steel tubing. The inner member is 2 1/2" square, 14-gauge steel tubing with a 1/4" steel plate welded on the bottom end. The foot consists of two formed and welded 11-gauge steel components and is attached to the column with 8mm bolts. Two 1 1/2" diameter nylon base leveling glides are threaded into the foot.

Worksurface Support

The worksurface support consists of two steel end supports and two steel cross supports welded together using rectangular steel tubing, 50mm x 25mm x 2mm wall thickness. The worksurface support is attached to the column with 8mm bolts.

Worksurface

Worksurfaces are constructed of 1 1/8" thick 45 lb. density particle board core. The top surface is covered with high-pressure laminate and the bottom surface is covered with phenolic backing sheet. The perimeter is finished using high impact plastic edging. The worksurface is pre-drilled and attached to the base using M5 x 70mm tapping screws.

Wire Trough

The wire trough is an optional accessory which must be ordered separately. Constructed of 18-gauge steel with a powder-coated finish which may be coordinated to match the color of table legs. Screws are provided for attachment to the underside of the tabletop, and tops are pre-drilled for wire trough locations. Provides six access holes to feed wires or install cable management systems.

WorkUp Crank-Base (Model CR)

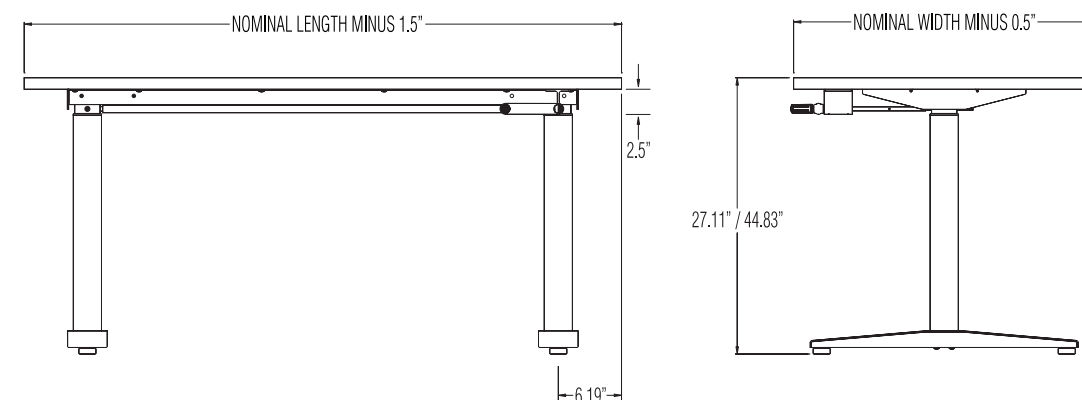

WorkUp Fixed-Base (Model FX)

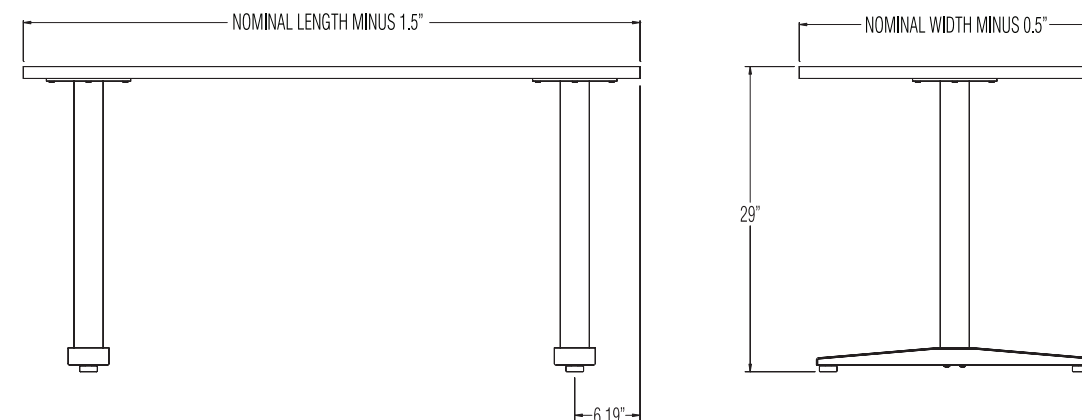

WorkUp ANSI/HFES Electric-Base (Model HF)

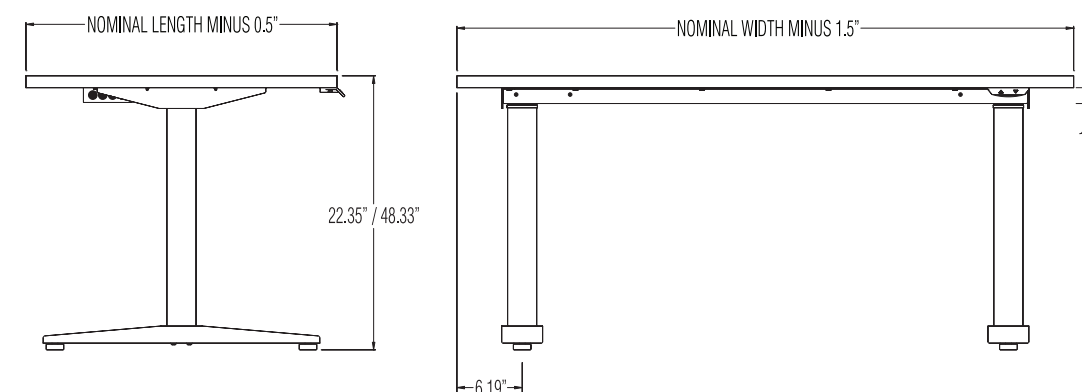



WorkUp Ratchet-Base (Model RT)

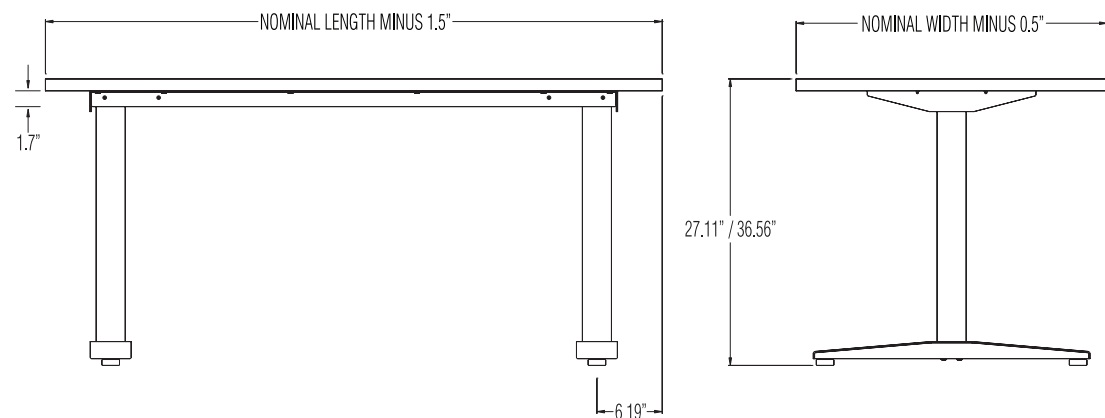

WorkUp Counterbalance-Base (Model CB)

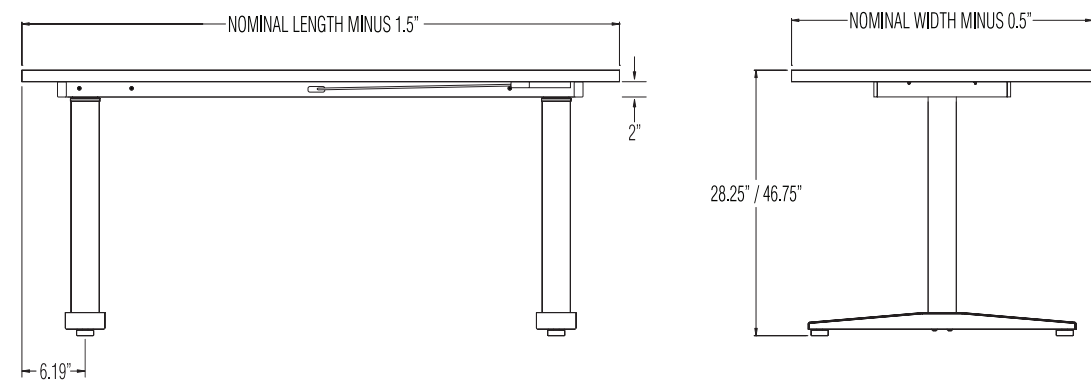

Wire Trough Width	Table Width
24"	48" & 54"
36"	60" & 66"
48"	72"

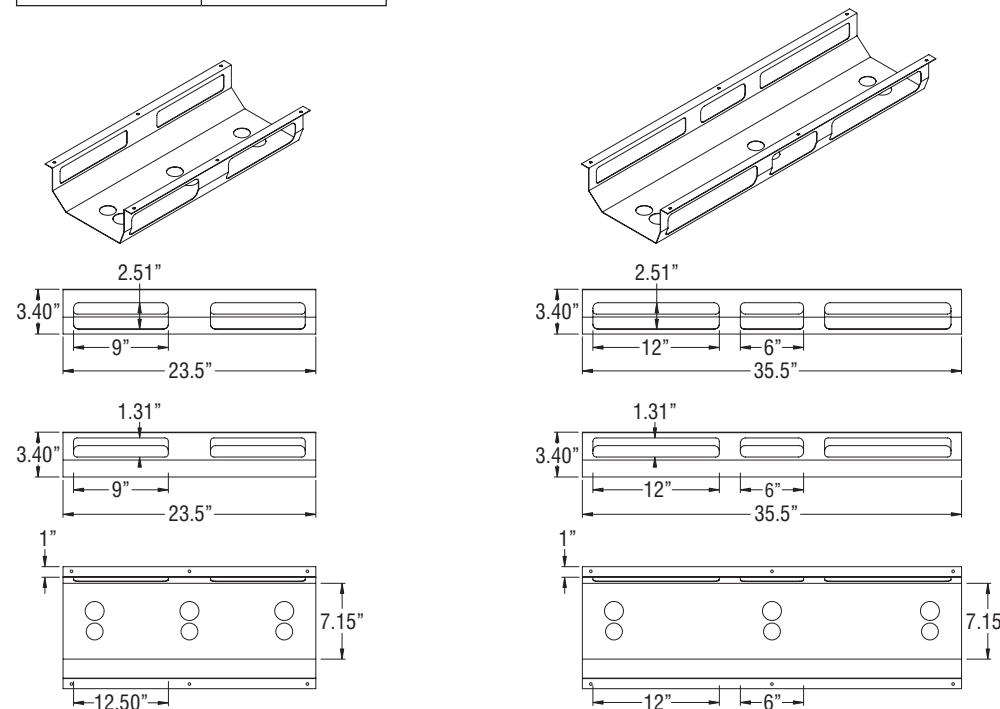

24" Wire Trough

36" Wire Trough

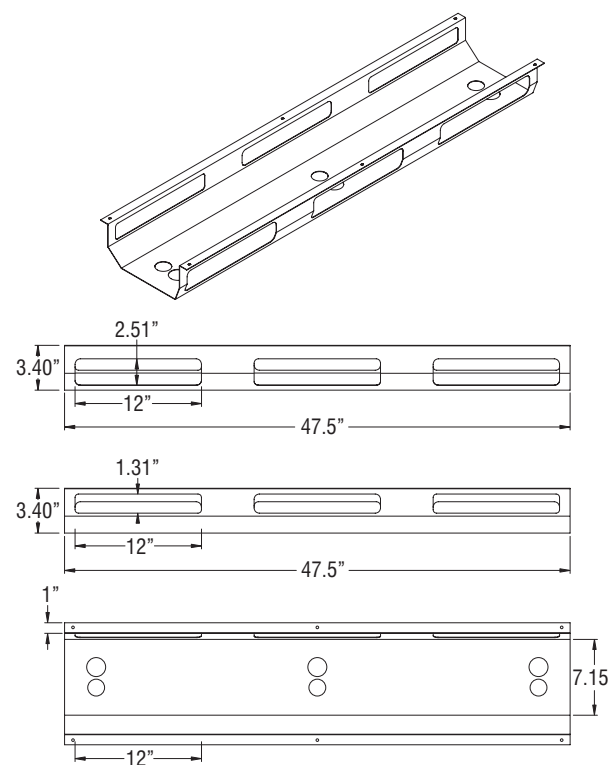

48" Wire Trough

Wire Trough Placement (Fixed-Base Tables)

For Fixed-Base Tables (excluding the 36" and 42" wide rectangular models), an optional wire trough can be mounted in the center of the tabletop, under the leg mounting plates. For 36" deep rectangular tables and 120-degree tables, the optional wire trough may also be mounted along the rear edge of the tabletops, behind the leg mounting plates, if desired. The optional wire troughs are not available for 36" and 42" wide rectangular tables due to insufficient clearance between the legs.

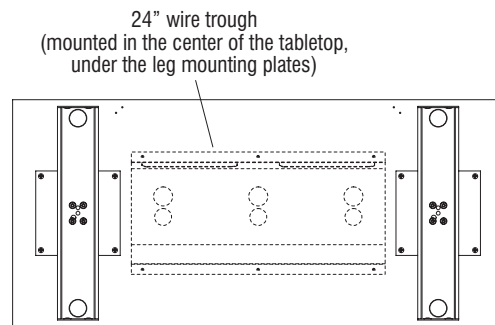

**WorkUp Rectangular Fixed-Base Tables,
22" -36" Deep (22" x 48" Model FX shown)**

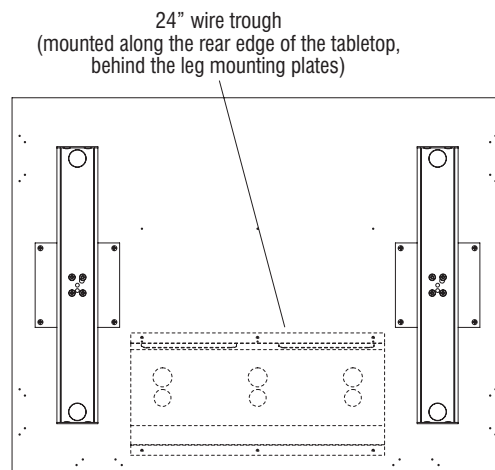

**WorkUp Rectangular Fixed-Base Tables,
36" Deep (36" x 48" Model FX shown)**

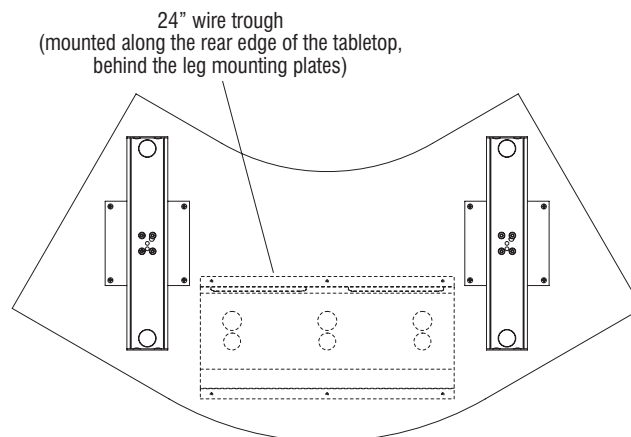

**WorkUp 120° Fixed-Base Tables, 24" Deep
(24" x 36" Model FX shown)**

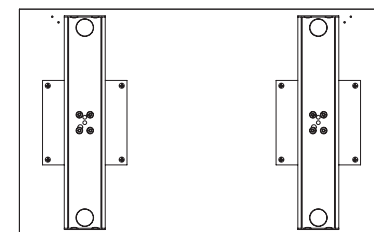

**WorkUp Rectangular Fixed-Base
Tables, 36" & 42" Wide
(22" x 36" Model FX shown)**

Wire Trough Placement (Ratchet, Crank & Counterbalance-Base Tables)

For Ratchet, Crank, and Counterbalance Tables, an optional wire trough can be mounted in the center of the tabletop. For 36" deep rectangular tables and 120-degree tables, the optional wire trough may also be mounted along the rear edge of the tabletops, behind the worksurface support beam, if desired.

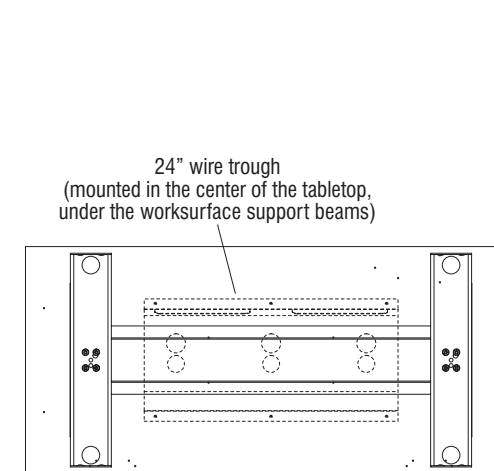

**WorkUp Rectangular Ratchet, Crank &
Counterbalance-Base Tables, 22" -36" Deep
(22" x 48" Model RT shown)**

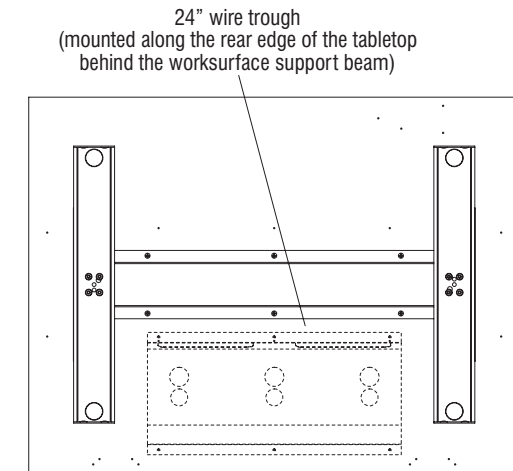

**WorkUp Rectangular Ratchet, Crank &
Counterbalance-Base Tables, 36" Deep
(36" x 48" Model RT shown)**

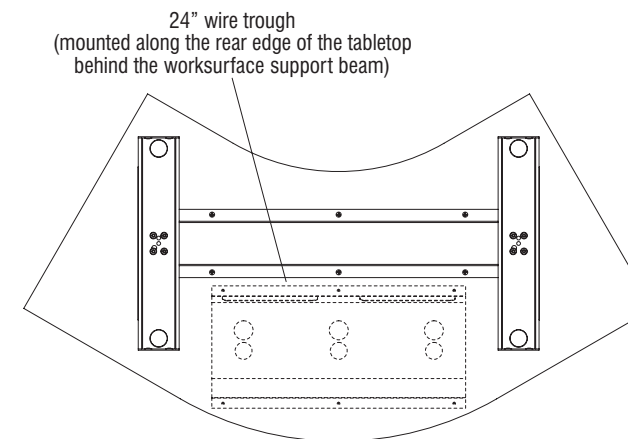

**WorkUp 120° Ratchet, Crank & Counterbalance-Base
Tables, 24" Deep (24" x 36" Model RT shown)**



Wire Trough Placement (Electric-Base Tables)

For Electric-Base Tables, an optional wire trough can be mounted in the center of the tabletop. For 22" & 24" deep rectangular tables, the optional wire trough can be mounted under the rear support beam. For 36" deep rectangular tables and 120-degree tables, the optional wire trough may also be mounted along the rear edge of the tabletops, behind the worksurface support beam, if desired.

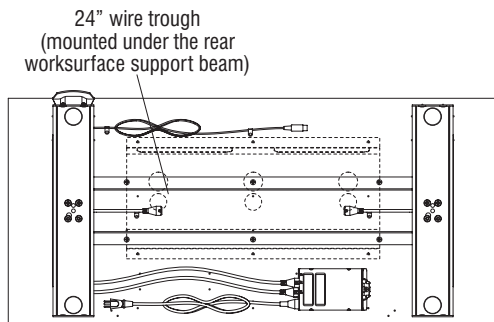

**WorkUp Rectangular Electric-Base Tables,
22"-24" Deep (22" x 48" Model HF shown)**

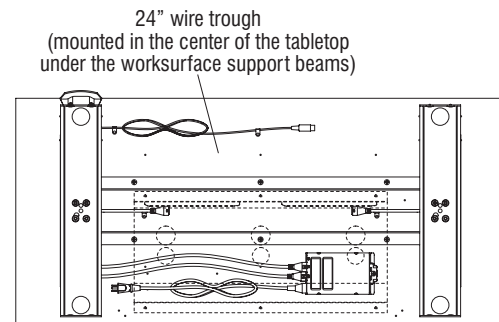

**WorkUp Rectangular Electric-Base Tables,
22"-36" Deep (22" x 48" Model HF shown)**

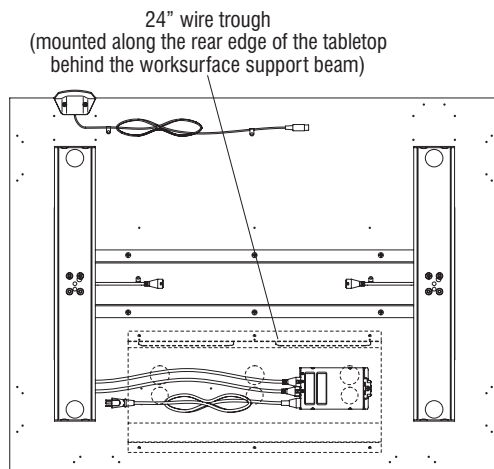

**WorkUp Rectangular Electric-Base Tables,
36" Deep (36" x 48" Model HF shown)**

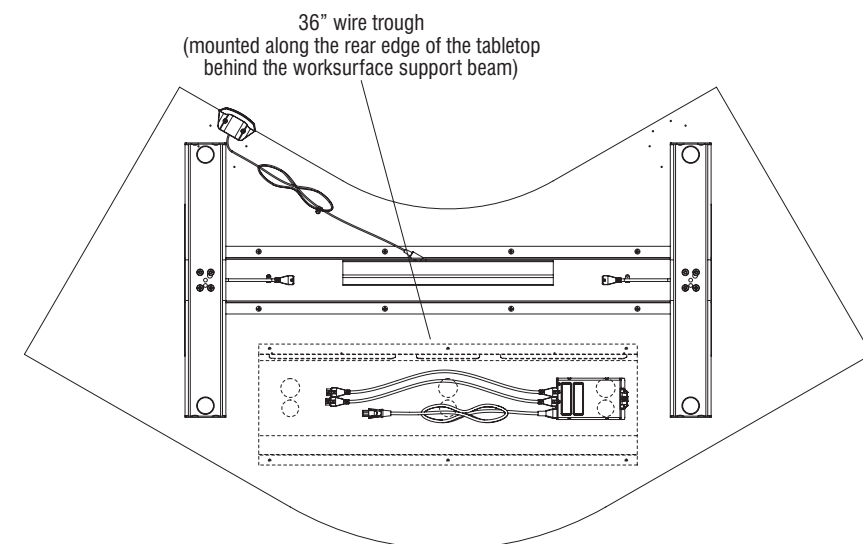

WorkUp 120° Electric-Base Tables, 30" Deep (30" x 48" Model HF shown)

STATEMENT OF LINE

WorkUp Ratchet, Crank, ANSI/HFES Electric and Counterbalance-Base Models

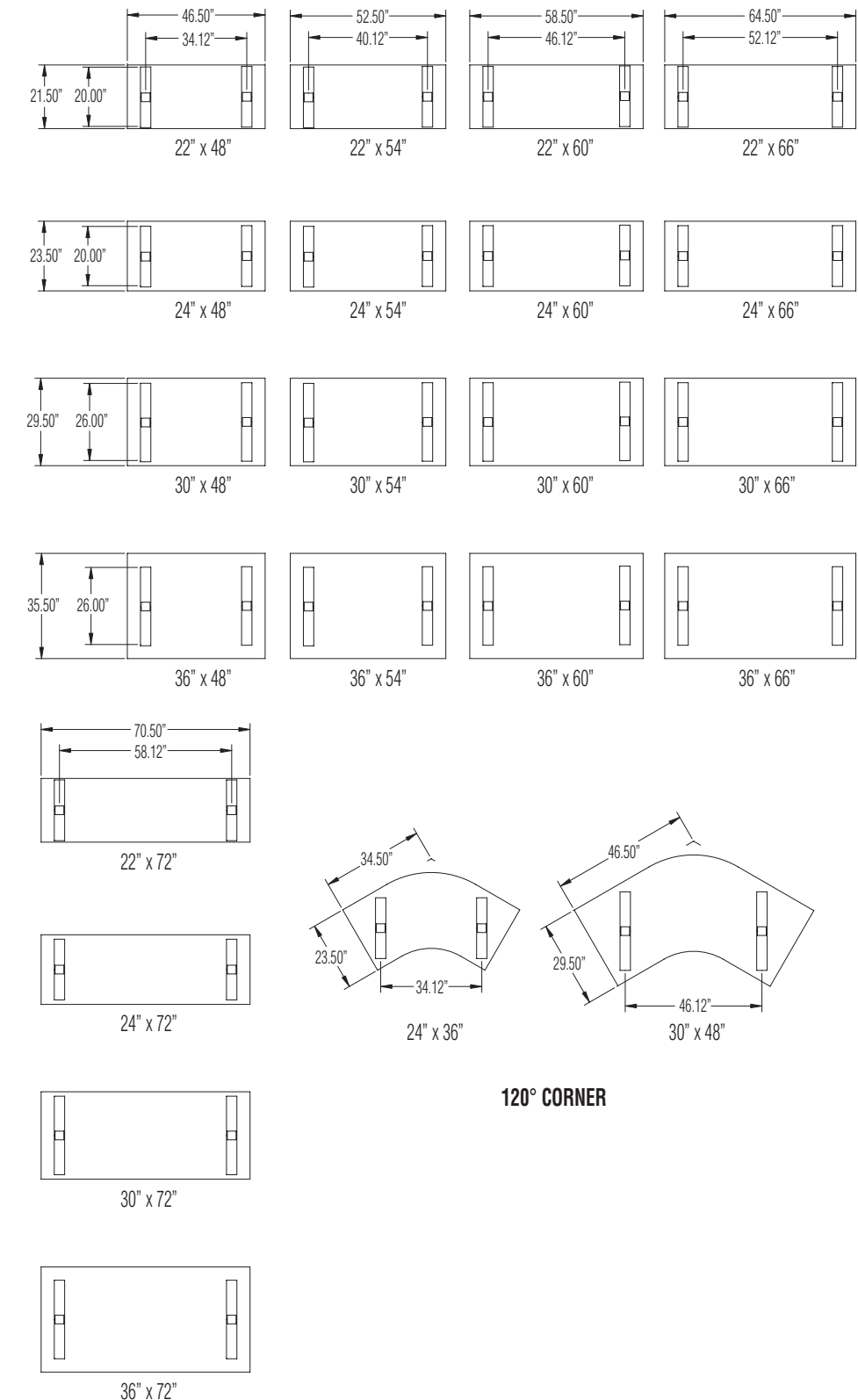



STATEMENT OF LINE (CONTINUED)

WorkUp Fixed-Base (Model FX)

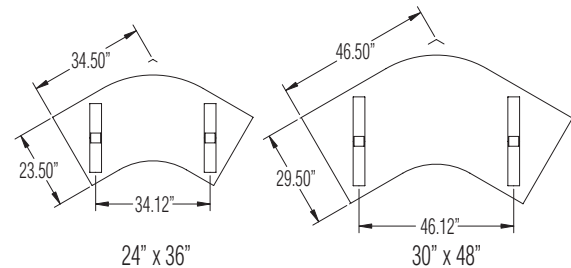
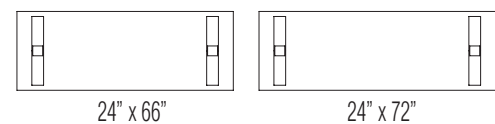
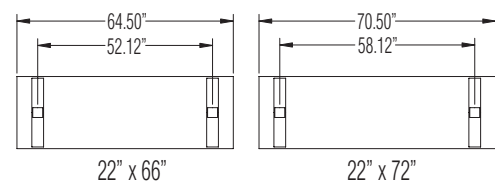
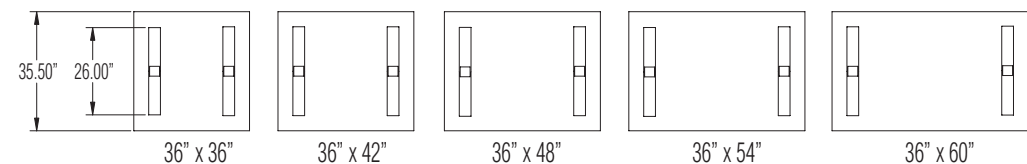
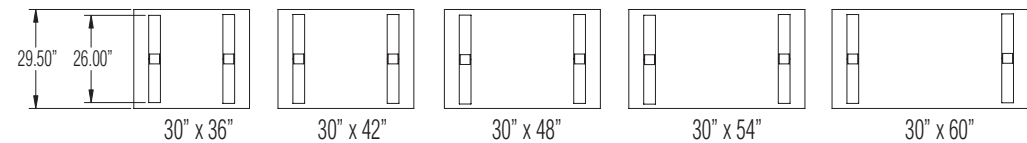
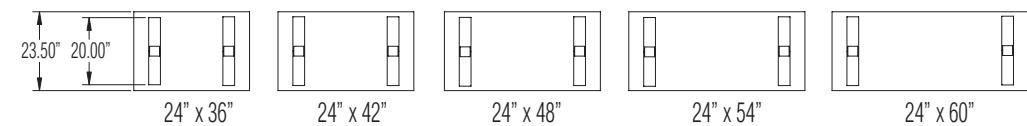
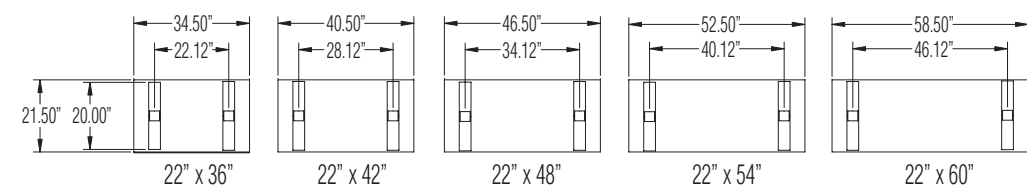

120° CORNER

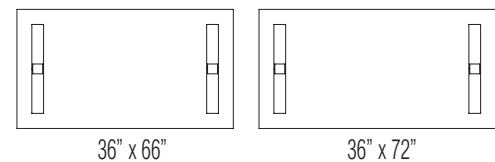
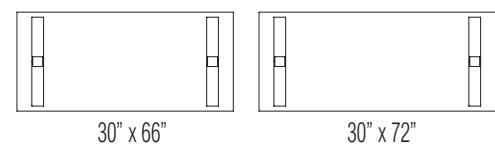



Surface Finish--Grade 1 Standard Laminate

Beigewood
Belair
Biltmore Cherry
Black
Brighton Walnut
Castle Oak
Cherry Storm
Classic Linen
Cocobala
Crisp Linen
Designer White
Dove Grey
Florence Walnut
Friston Ash
Frosty White
Graphite Nebula
Grey
High Rise
Hollyberry
Island
Italian Silver Ash
Kensington Maple
Lapis Blue
Monticello Maple
North Sea
Ocean
Pinnacle Walnut
River Cherry
Shadow Zephyr
Sterling Ash
Titanium Evolv
White Nebula
White Sand
Windsor Mahogany

Surface Finish--Grade 2 Standard Laminate

Akira
Black Alicante
Black Hills Oak
Calcutta Marble
Dering Forest
Fawn Cypress
Ice Mist
Markerboard White
Valley Forge Elm
White River Forest

Surface Finish--Grade 3 Standard Laminate

Black Velvet
Cumberland Walnut
Designer White Velvet
Hartley Walnut
Nile Velvet
Raleigh Walnut
Solano Walnut
Spruce Velvet

Base and Trough Paint Color

LBZ	Black
LBQ	Blue Grey
LBT	Bronze Metallic
LBK	Champagne Metallic
LBW	Cool Grey
LCO	Cottonwood
LCX	Earthen Clay
LCI	Everglade Shade
LCC	Glitz Metallic
LRI	Hazy Jade
LDR	Honey Bee
LDG	Mardi Gras
LFC	Misty Brown
LFH	Nemo
LPW	Purple Haze
LGN	Rainforest
LGE	Raw Jasper
LHE	Rubber Ducky
LHY	Starlight Silver Metallic
LID	Surf's Up
LIT	Tarragon
LKM	Twilight Shadow
LLB	Ultra Blue
LMT	Warm Grey
LNA	Zesty Lime

Edge Color for 74P Edge

LPW	Akira
LRY	Beigewood
LSR	Belair
LAZ	Biltmore Cherry
LTV	Black
LWL	Black Hills Oak
LWN	Blue Grey
LWY	Brighton Walnut
	Castle Oak
LAK	Cayenne
LBY	Cherry Storm
LBH	Cocobala
LCQ	Cool Grey
LDF	Cumberland Walnut
LFQ	Dering Forest
LIM	Designer White
LMK	Everglade Shade
LVF	Fawn Cypress
LWR	Flannel
	Florence Walnut
	Friston Ash
LBV	Frosty White
LCJ	Hartley Walnut
LDE	Hazy Jade
LHW	Italian Silver Ash
LNL	Kensington Maple
LRW	Light Tone
LSG	Mardi Gras
LSC	Misty Brown
	Monticello Maple

Multiplex	
BL	Nemo
GR	Nordic
ZM	Pinnacle Walnut
CM	Poppy Red
CG	Rainforest
CO	Raleigh Walnut
EY	River Cherry
EV	Rubber Ducky
GZ	Sand
HJ	Sky Blue
HY	Solano Walnut
MG	Sterling Ash
MY	Surf's Up
NE	Tarragon
PH	Twilight Shadow
RQ	Ultra Blue
RJ	Valley Forge Elm
RK	Warm Grey
SX	White River Forest
SP	Windsor Mahogany
TQ	Zesty Lime
TI	

Edge Color for KN Edge

UB	Akira
WG	Beigewood
ZL	Belair
	Biltmore Cherry
EAK	Black
EBZ	Black Hills Oak
EBQ	Blue Grey
EBT	Brighton Walnut
EBL	Castle Oak
EBH	Cayenne
EGR	Cherry Storm
EBW	Cocobala
ECC	Cool Grey
ECG	Cumberland Walnut
ECY	Cumberland Walnut
ECX	Dering Forest
ECC	Designer White
ECG	Everglade Shade
ECJ	Fawn Cypress
EDF	Flannel
EDR	Florence Walnut
EEV	Friston Ash
EFQ	Frosty White
EFN	Hartley Walnut
EFC	Hazy Jade
EFH	Italian Silver Ash
EFW	Kensington Maple
EHW	Light Tone
EHJ	Mardi Gras
EIT	Misty Brown
EKM	Monticello Maple
ELG	Nemo
EMG	Nordic
EMY	Pinnacle Walnut
EMT	Poppy Red

EMB	Rainforest
ENE	Raleigh Walnut
END	River Cherry
EPW	Rubber Ducky
EPR	Sand
ERQ	Sky Blue
ERW	Solano Walnut
ERY	Sterling Ash
ERK	Surf's Up
ESA	Tarragon
ESK	Twilight Shadow
ESG	Ultra Blue
EAZ	Valley Forge Elm
ESP	Warm Grey
ETQ	White River Forest
ETI	Windsor Mahogany
EUB	Zesty Lime
EVF	
EWG	Inner Column Color
EWR	Black
EWY	Silver
EZL	White

Polyester Felt Modesty Panel

EAK	Dandelion
EBZ	Fawn
EBQ	Flannel
EBT	Heather
EBL	Lava
EBH	Mallard
EGR	Midnight Blue
EBW	Pepper
ECO	Spring
ECY	Tidal Wave
ECX	
ECC	
ECG	
ECJ	
EDF	
EDR	
EEV	
EFQ	
EFN	
EFC	
EFH	
EFW	
EHW	
EHJ	
EIT	
EKM	
ELG	
EMG	
EMY	
EMT	
ENE	
END	
EPW	
EPR	

ERQ
ERW
ERY
ERK
ESA
ESK
ESG
EAZ
ESP
ETQ
ETI
EUB
EVF
EWG
EWR
EWY
EZL

IBL
ISV
IWH

FTDD
FTFW
FTFN
FTHR
FTLV
FTML
FTMB
FTPR
FTSG
FTTW

Finish Cards

View color swatches for items listed within this document.

- Paints**
- Wood/Veneer**
- Molded Edges**
- Hard Plastics**
- Plastics/Poly**
- Laminates**
- Edge Styles**
- Glass**

Certain options referenced may not be available on GSA Schedule.



MODEL	A x B x C	MODEL NUMBER								Approx. Packaged Weight	74P Edge (74P)	Postformed Edge (PL)	Knife Edge (KN)	Laminate Grade 2 add to list price	Laminate Grade 3 add to list price
		Basic Model	Edge Style	Modesty Panel	Base	Edge Color	Surface Finish	Base Finish	Polyester Modesty Panel Color						
<p>Rectangular Tables - 22" D</p> <ul style="list-style-type: none"> • 29" height • Adjustable glides 	21-1/2 x 34-1/2"	WU2236FX	<input type="checkbox"/>	<input type="checkbox"/>	<input type="checkbox"/>	<input type="checkbox"/>	<input type="checkbox"/>	<input type="checkbox"/>	<input type="checkbox"/>	69.0#	\$ 863	\$ 896	\$ 927	\$ 19	\$ 120
	21-1/2 x 40-1/2"	WU2242FX	<input type="checkbox"/>	<input type="checkbox"/>	<input type="checkbox"/>	<input type="checkbox"/>	<input type="checkbox"/>	<input type="checkbox"/>	<input type="checkbox"/>	66.0#	915	953	985	19	120
	21-1/2 x 46-1/2"	WU2248FX	<input type="checkbox"/>	<input type="checkbox"/>	<input type="checkbox"/>	<input type="checkbox"/>	<input type="checkbox"/>	<input type="checkbox"/>	<input type="checkbox"/>	70.0#	926	961	990	19	120
	21-1/2 x 52-1/2"	WU2254FX	<input type="checkbox"/>	<input type="checkbox"/>	<input type="checkbox"/>	<input type="checkbox"/>	<input type="checkbox"/>	<input type="checkbox"/>	<input type="checkbox"/>	75.0#	981	1021	1071	27	178
	21-1/2 x 58-1/2"	WU2260FX	<input type="checkbox"/>	<input type="checkbox"/>	<input type="checkbox"/>	<input type="checkbox"/>	<input type="checkbox"/>	<input type="checkbox"/>	<input type="checkbox"/>	79.0#	985	1025	1074	27	178
	21-1/2 x 64-1/2"	WU2266FX	<input type="checkbox"/>	<input type="checkbox"/>	<input type="checkbox"/>	<input type="checkbox"/>	<input type="checkbox"/>	<input type="checkbox"/>	<input type="checkbox"/>	91.0#	1056	1098	1189	27	178
	21-1/2 x 70-1/2"	WU2272FX	<input type="checkbox"/>	<input type="checkbox"/>	<input type="checkbox"/>	<input type="checkbox"/>	<input type="checkbox"/>	<input type="checkbox"/>	<input type="checkbox"/>	95.0#	1060	1101	1193	27	178
<p>Rectangular Tables - 24" D</p> <ul style="list-style-type: none"> • 29" height • Adjustable glides 	23-1/2 x 34-1/2"	WU2436FX	<input type="checkbox"/>	<input type="checkbox"/>	<input type="checkbox"/>	<input type="checkbox"/>	<input type="checkbox"/>	<input type="checkbox"/>	<input type="checkbox"/>	64.0#	\$ 863	\$ 896	\$ 930	\$ 19	\$ 120
	23-1/2 x 40-1/2"	WU2442FX	<input type="checkbox"/>	<input type="checkbox"/>	<input type="checkbox"/>	<input type="checkbox"/>	<input type="checkbox"/>	<input type="checkbox"/>	<input type="checkbox"/>	69.0#	915	953	985	19	120
	23-1/2 x 46-1/2"	WU2448FX	<input type="checkbox"/>	<input type="checkbox"/>	<input type="checkbox"/>	<input type="checkbox"/>	<input type="checkbox"/>	<input type="checkbox"/>	<input type="checkbox"/>	73.0#	925	961	992	19	120
	23-1/2 x 52-1/2"	WU2454FX	<input type="checkbox"/>	<input type="checkbox"/>	<input type="checkbox"/>	<input type="checkbox"/>	<input type="checkbox"/>	<input type="checkbox"/>	<input type="checkbox"/>	78.0#	983	1021	1071	27	178
	23-1/2 x 58-1/2"	WU2460FX	<input type="checkbox"/>	<input type="checkbox"/>	<input type="checkbox"/>	<input type="checkbox"/>	<input type="checkbox"/>	<input type="checkbox"/>	<input type="checkbox"/>	83.0#	986	1025	1074	27	178
	23-1/2 x 64-1/2"	WU2466FX	<input type="checkbox"/>	<input type="checkbox"/>	<input type="checkbox"/>	<input type="checkbox"/>	<input type="checkbox"/>	<input type="checkbox"/>	<input type="checkbox"/>	95.0#	1058	1098	1189	27	178
	23-1/2 x 70-1/2"	WU2472FX	<input type="checkbox"/>	<input type="checkbox"/>	<input type="checkbox"/>	<input type="checkbox"/>	<input type="checkbox"/>	<input type="checkbox"/>	<input type="checkbox"/>	100.0#	1060	1105	1193	27	178
<p>Rectangular Tables - 30" D</p> <ul style="list-style-type: none"> • 29" height • Adjustable glides 	29-1/2 x 34-1/2"	WU3036FX	<input type="checkbox"/>	<input type="checkbox"/>	<input type="checkbox"/>	<input type="checkbox"/>	<input type="checkbox"/>	<input type="checkbox"/>	<input type="checkbox"/>	75.0#	\$ 910	\$ 943	\$ 1024	\$ 27	\$ 178
	29-1/2 x 40-1/2"	WU3042FX	<input type="checkbox"/>	<input type="checkbox"/>	<input type="checkbox"/>	<input type="checkbox"/>	<input type="checkbox"/>	<input type="checkbox"/>	<input type="checkbox"/>	81.0#	973	1012	1056	27	178
	29-1/2 x 46-1/2"	WU3048FX	<input type="checkbox"/>	<input type="checkbox"/>	<input type="checkbox"/>	<input type="checkbox"/>	<input type="checkbox"/>	<input type="checkbox"/>	<input type="checkbox"/>	87.0#	1025	1060	1065	27	178
	29-1/2 x 52-1/2"	WU3054FX	<input type="checkbox"/>	<input type="checkbox"/>	<input type="checkbox"/>	<input type="checkbox"/>	<input type="checkbox"/>	<input type="checkbox"/>	<input type="checkbox"/>	93.0#	1133	1180	1242	27	178
	29-1/2 x 58-1/2"	WU3060FX	<input type="checkbox"/>	<input type="checkbox"/>	<input type="checkbox"/>	<input type="checkbox"/>	<input type="checkbox"/>	<input type="checkbox"/>	<input type="checkbox"/>	99.0#	1136	1184	1247	27	178
	29-1/2 x 64-1/2"	WU3066FX	<input type="checkbox"/>	<input type="checkbox"/>	<input type="checkbox"/>	<input type="checkbox"/>	<input type="checkbox"/>	<input type="checkbox"/>	<input type="checkbox"/>	112.0#	1213	1261	1375	27	178
	29-1/2 x 70-1/2"	WU3072FX	<input type="checkbox"/>	<input type="checkbox"/>	<input type="checkbox"/>	<input type="checkbox"/>	<input type="checkbox"/>	<input type="checkbox"/>	<input type="checkbox"/>	118.0#	1218	1267	1382	27	178
<p>Rectangular Tables - 36" D</p> <ul style="list-style-type: none"> • 29" height • Adjustable glides 	35-1/2 x 34-1/2"	WU3636FX	<input type="checkbox"/>	<input type="checkbox"/>	<input type="checkbox"/>	<input type="checkbox"/>	<input type="checkbox"/>	<input type="checkbox"/>	<input type="checkbox"/>	82.0#	\$ 986	\$ 1026	\$ 1098	\$ 37	\$ 235
	35-1/2 x 40-1/2"	WU3642FX	<input type="checkbox"/>	<input type="checkbox"/>	<input type="checkbox"/>	<input type="checkbox"/>	<input type="checkbox"/>	<input type="checkbox"/>	<input type="checkbox"/>	89.0#	1065	1109	1196	37	235
	35-1/2 x 46-1/2"	WU3648FX	<input type="checkbox"/>	<input type="checkbox"/>	<input type="checkbox"/>	<input type="checkbox"/>	<input type="checkbox"/>	<input type="checkbox"/>	<input type="checkbox"/>	96.0#	1074	1116	1204	37	235
	35-1/2 x 52-1/2"	WU3654FX	<input type="checkbox"/>	<input type="checkbox"/>	<input type="checkbox"/>	<input type="checkbox"/>	<input type="checkbox"/>	<input type="checkbox"/>	<input type="checkbox"/>	103.0#	1190	1238	1449	53	368
	35-1/2 x 58-1/2"	WU3660FX	<input type="checkbox"/>	<input type="checkbox"/>	<input type="checkbox"/>	<input type="checkbox"/>	<input type="checkbox"/>	<input type="checkbox"/>	<input type="checkbox"/>	110.0#	1194	1241	1356	53	368
	35-1/2 x 64-1/2"	WU3666FX	<input type="checkbox"/>	<input type="checkbox"/>	<input type="checkbox"/>	<input type="checkbox"/>	<input type="checkbox"/>	<input type="checkbox"/>	<input type="checkbox"/>	125.0#	1230	1278	1775	53	368
	35-1/2 x 70-1/2"	WU3672FX	<input type="checkbox"/>	<input type="checkbox"/>	<input type="checkbox"/>	<input type="checkbox"/>	<input type="checkbox"/>	<input type="checkbox"/>	<input type="checkbox"/>	132.0#	1238	1287	1783	53	368

A **B** **C** **D** **E** **F** **G** **H**

HOW TO ORDER

- Indicate the following information on order form:
- Quantity of each item.
 - Model number, including options. See "How To Build a Model Number".
 - Any special service required.

Note: • The indicates that a choice is required.
 • The absence of the indicates that no choice is required.
 • Alpha-numeric characters in place of indicate that no other alternatives are available.

HOW TO BUILD A MODEL NUMBER

- A** Select basic model.
- B** Select edge style.
 - 74P** - 74P edge
 - PL** - Postformed edge
 - KN** - Knife edge
 Knife edge (KN) and Postformed edge (PL) on user side only
- C** Select modesty panel.
 - NMP** - No modesty panel
 - PMP** - Polyester felt modesty panel; add \$203
- D** Select base option.
 - G** - Glides
 - R** - Rolling base (1 foot w/rollers, 1 foot w/glides); add \$60
- E** Select edge color. Refer to the **Product Color Options** page in this price list. Edge color offerings are based on edge style selections.
- F** Select surface finish. Refer to the **Product Color Options** page in this price list. Surface finish offerings are based on edge style selections.
- G** Select base finish. Refer to the **Product Color Options** page in this price list.
- H** Select modesty panel color (only if polyester felt panel is chosen). Refer to the **Product Color Options** page in this price list.

SPECIAL SERVICES

Special Carton Marking

With specially marked information N/C

Shipping

Ships **knocked down, FOB Bonduel, WI 54107, freight prepaid.** Freight class 125.

Specifications and prices are subject to change without prior notice.

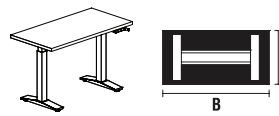

	A x B x C	MODEL NUMBER									Approx. Packaged Weight	74P Edge (74P)	Postformed Edge (PL)	Knife Edge (KN)	Laminate Grade 2 add to list price	Laminate Grade 3 add to list price
		Basic Model	Edge Style	Modesty Panel	Base	Edge Color	Surface Finish	Base Finish	Column Finish	Polyester Modesty Panel Color						
 <p>WUCR Rectangular Tables - 22" D</p> <ul style="list-style-type: none"> • 27-44" adjustable heights • Adjustable glides • Adjusts at a rate of 6-1/3 turns per inch 	21-1/2 x 46-1/2"	WU2248CR	<input type="checkbox"/>	<input type="checkbox"/>	<input type="checkbox"/>	<input type="checkbox"/>	<input type="checkbox"/>	<input type="checkbox"/>	<input type="checkbox"/>	84.0#	\$ 1724	\$ 1785	\$ 1789	\$ 19	\$ 120	
	21-1/2 x 52-1/2"	WU2254CR	<input type="checkbox"/>	<input type="checkbox"/>	<input type="checkbox"/>	<input type="checkbox"/>	<input type="checkbox"/>	<input type="checkbox"/>	<input type="checkbox"/>	90.0#	1784	1856	1873	27	178	
	21-1/2 x 58-1/2"	WU2260CR	<input type="checkbox"/>	<input type="checkbox"/>	<input type="checkbox"/>	<input type="checkbox"/>	<input type="checkbox"/>	<input type="checkbox"/>	<input type="checkbox"/>	95.0#	1797	1869	1887	27	178	
	21-1/2 x 64-1/2"	WU2266CR	<input type="checkbox"/>	<input type="checkbox"/>	<input type="checkbox"/>	<input type="checkbox"/>	<input type="checkbox"/>	<input type="checkbox"/>	<input type="checkbox"/>	101.0#	1882	1956	2013	27	178	
	21-1/2 x 70-1/2"	WU2272CR	<input type="checkbox"/>	<input type="checkbox"/>	<input type="checkbox"/>	<input type="checkbox"/>	<input type="checkbox"/>	<input type="checkbox"/>	<input type="checkbox"/>	106.0#	1894	1968	2026	27	178	
<p>WUCR Rectangular Tables - 24" D</p> <ul style="list-style-type: none"> • 27-44" adjustable heights • Adjustable glides • Adjusts at a rate of 6-1/3 turns per inch 	23-1/2 x 46-1/2"	WU2448CR	<input type="checkbox"/>	<input type="checkbox"/>	<input type="checkbox"/>	<input type="checkbox"/>	<input type="checkbox"/>	<input type="checkbox"/>	<input type="checkbox"/>	87.0#	\$ 1724	\$ 1785	\$ 1789	\$ 19	\$ 120	
	23-1/2 x 52-1/2"	WU2454CR	<input type="checkbox"/>	<input type="checkbox"/>	<input type="checkbox"/>	<input type="checkbox"/>	<input type="checkbox"/>	<input type="checkbox"/>	<input type="checkbox"/>	93.0#	1785	1856	1877	27	178	
	23-1/2 x 58-1/2"	WU2460CR	<input type="checkbox"/>	<input type="checkbox"/>	<input type="checkbox"/>	<input type="checkbox"/>	<input type="checkbox"/>	<input type="checkbox"/>	<input type="checkbox"/>	99.0#	1798	1869	1887	27	178	
	23-1/2 x 64-1/2"	WU2466CR	<input type="checkbox"/>	<input type="checkbox"/>	<input type="checkbox"/>	<input type="checkbox"/>	<input type="checkbox"/>	<input type="checkbox"/>	<input type="checkbox"/>	105.0#	1931	2005	2014	27	178	
	23-1/2 x 70-1/2"	WU2472CR	<input type="checkbox"/>	<input type="checkbox"/>	<input type="checkbox"/>	<input type="checkbox"/>	<input type="checkbox"/>	<input type="checkbox"/>	<input type="checkbox"/>	111.0#	1941	2020	2073	27	178	
<p>WUCR Rectangular Tables - 30" D</p> <ul style="list-style-type: none"> • 27-44" adjustable heights • Adjustable glides • Adjusts at a rate of 6-1/3 turns per inch 	29-1/2 x 46-1/2"	WU3048CR	<input type="checkbox"/>	<input type="checkbox"/>	<input type="checkbox"/>	<input type="checkbox"/>	<input type="checkbox"/>	<input type="checkbox"/>	<input type="checkbox"/>	103.0#	\$ 1863	\$ 1940	\$ 1948	\$ 27	\$ 178	
	29-1/2 x 52-1/2"	WU3054CR	<input type="checkbox"/>	<input type="checkbox"/>	<input type="checkbox"/>	<input type="checkbox"/>	<input type="checkbox"/>	<input type="checkbox"/>	<input type="checkbox"/>	110.0#	1983	2058	2091	27	178	
	29-1/2 x 58-1/2"	WU3060CR	<input type="checkbox"/>	<input type="checkbox"/>	<input type="checkbox"/>	<input type="checkbox"/>	<input type="checkbox"/>	<input type="checkbox"/>	<input type="checkbox"/>	117.0#	1995	2074	2104	27	178	
	29-1/2 x 64-1/2"	WU3066CR	<input type="checkbox"/>	<input type="checkbox"/>	<input type="checkbox"/>	<input type="checkbox"/>	<input type="checkbox"/>	<input type="checkbox"/>	<input type="checkbox"/>	124.0#	2079	2162	2242	27	178	
	29-1/2 x 70-1/2"	WU3072CR	<input type="checkbox"/>	<input type="checkbox"/>	<input type="checkbox"/>	<input type="checkbox"/>	<input type="checkbox"/>	<input type="checkbox"/>	<input type="checkbox"/>	131.0#	2094	2177	2255	27	178	
<p>WUCR Rectangular Tables - 36" D</p> <ul style="list-style-type: none"> • 27-44" adjustable heights • Adjustable glides • Adjusts at a rate of 6-1/3 turns per inch 	35-1/2 x 46-1/2"	WU3648CR	<input type="checkbox"/>	<input type="checkbox"/>	<input type="checkbox"/>	<input type="checkbox"/>	<input type="checkbox"/>	<input type="checkbox"/>	<input type="checkbox"/>	112.0#	\$ 1913	\$ 1991	\$ 2044	\$ 37	\$ 235	
	35-1/2 x 52-1/2"	WU3654CR	<input type="checkbox"/>	<input type="checkbox"/>	<input type="checkbox"/>	<input type="checkbox"/>	<input type="checkbox"/>	<input type="checkbox"/>	<input type="checkbox"/>	121.0#	2037	2118	2296	53	368	
	35-1/2 x 58-1/2"	WU3660CR	<input type="checkbox"/>	<input type="checkbox"/>	<input type="checkbox"/>	<input type="checkbox"/>	<input type="checkbox"/>	<input type="checkbox"/>	<input type="checkbox"/>	129.0#	2049	2134	2211	53	368	
	35-1/2 x 64-1/2"	WU3666CR	<input type="checkbox"/>	<input type="checkbox"/>	<input type="checkbox"/>	<input type="checkbox"/>	<input type="checkbox"/>	<input type="checkbox"/>	<input type="checkbox"/>	137.0#	2086	2167	2630	53	368	
	35-1/2 x 70-1/2"	WU3672CR	<input type="checkbox"/>	<input type="checkbox"/>	<input type="checkbox"/>	<input type="checkbox"/>	<input type="checkbox"/>	<input type="checkbox"/>	<input type="checkbox"/>	146.0#	2100	2183	2647	53	368	

A B C D E F G H I

HOW TO ORDER

- Indicate the following information on order form:
- Quantity of each item.
 - Model number, including options. See "How to Build a Model Number".
 - Any special service required.

Note: • The indicates that a choice is required.
 • The absence of the indicates that no choice is required.
 • Alpha-numeric characters in place of indicate that no other alternatives are available.

HOW TO BUILD A MODEL NUMBER

- A** Select basic model.
- B** Select edge style.
74P - 74P edge
PL - Postformed edge
KN - Knife edge
 Knife edge (KN) and Postformed edge (PL) on user side only
- C** Select modesty panel.
NMP - No modesty panel
PMP - Polyester felt modesty panel; add \$203
- D** Select base option.
G - Glides
R - Rolling base (1 foot w/rollers, 1 foot w/glides); add \$60
- E** Select edge color.
 Refer to the **Product Color Options** page in this price list.
 Edge color offerings are based on edge style
- F** Select surface finish.
 Refer to the **Product Color Options** page in this price list.
 Surface finish offerings are based on edge style selections.
- G** Select base finish.
 Refer to the **Product Color Options** page in this price list.
- H** Select inner column finish.
 Refer to the **Product Color Options** page in this price list.
- I** Select modesty panel color (only if polyester felt panel is chosen).
 Refer to the **Product Color Options** page in this price list.

SPECIAL SERVICES

Special Carton Marking

With specially marked information N/C

Shipping
 Ships **knocked down, FOB Bonduel, WI 54107, freight prepaid.** Freight class 125.

Specifications and prices are subject to change without prior notice.



A x B x C	MODEL NUMBER										Approx. Packaged Weight	74P Edge (74P)	Postformed Edge (PL)	Knife Edge (KN)	Laminate Grade 2 add to list price	Laminate Grade 3 add to list price
	Basic Model	Edge Style	Modesty Panel	Base	Edge Color	Surface Finish	Foot Finish	Frame/Inner Column Finish	Polyester Modesty Panel Color							
 WUCB Rectangular Tables - 22"D • Designed to support 15 to 45 lbs of equipment (non-standard weight ranges available through Product Modification Request) • 28-47" adjustable heights • Foot Finish is for foot weldments only • Frame/inner column finish is for under structure and inner/outer leg columns	21-1/2 x 46-1/2"	WU2248CB	<input type="checkbox"/>	<input type="checkbox"/>	<input type="checkbox"/>	<input type="checkbox"/>	<input type="checkbox"/>	93.0#	\$ 3022	\$ 3029	\$ 3091	\$ 19	\$ 120			
	21-1/2 x 52-1/2"	WU2254CB	<input type="checkbox"/>	<input type="checkbox"/>	<input type="checkbox"/>	<input type="checkbox"/>	<input type="checkbox"/>	98.0#	3096	3122	3185	27	178			
	21-1/2 x 58-1/2"	WU2260CB	<input type="checkbox"/>	<input type="checkbox"/>	<input type="checkbox"/>	<input type="checkbox"/>	<input type="checkbox"/>	102.0#	3118	3143	3203	27	178			
	21-1/2 x 64-1/2"	WU2266CB	<input type="checkbox"/>	<input type="checkbox"/>	<input type="checkbox"/>	<input type="checkbox"/>	<input type="checkbox"/>	107.0#	3194	3204	3325	27	178			
	21-1/2 x 70-1/2"	WU2272CB	<input type="checkbox"/>	<input type="checkbox"/>	<input type="checkbox"/>	<input type="checkbox"/>	<input type="checkbox"/>	112.0#	3209	3225	3340	27	178			
WUCB Rectangular Tables - 24"D • Designed to support 15 to 45 lbs of equipment (non-standard weight ranges available through Product Modification Request) • 28-47" adjustable heights • Foot Finish is for foot weldments only • Frame/inner column finish is for under structure and inner/outer leg columns	23-1/2 x 46-1/2"	WU2448CB	<input type="checkbox"/>	<input type="checkbox"/>	<input type="checkbox"/>	<input type="checkbox"/>	<input type="checkbox"/>	96.0#	\$ 3022	\$ 3027	\$ 3091	\$ 19	\$ 120			
	23-1/2 x 52-1/2"	WU2454CB	<input type="checkbox"/>	<input type="checkbox"/>	<input type="checkbox"/>	<input type="checkbox"/>	<input type="checkbox"/>	101.0#	3096	3121	3185	27	178			
	23-1/2 x 58-1/2"	WU2460CB	<input type="checkbox"/>	<input type="checkbox"/>	<input type="checkbox"/>	<input type="checkbox"/>	<input type="checkbox"/>	106.0#	3118	3141	3203	27	178			
	23-1/2 x 64-1/2"	WU2466CB	<input type="checkbox"/>	<input type="checkbox"/>	<input type="checkbox"/>	<input type="checkbox"/>	<input type="checkbox"/>	111.0#	3194	3203	3325	27	178			
	23-1/2 x 70-1/2"	WU2472CB	<input type="checkbox"/>	<input type="checkbox"/>	<input type="checkbox"/>	<input type="checkbox"/>	<input type="checkbox"/>	116.0#	3209	3224	3340	27	178			
WUCB Rectangular Tables - 30"D • Designed to support 15 to 45 lbs of equipment (non-standard weight ranges available through Product Modification Request) • 28-47" adjustable heights • Foot Finish is for foot weldments only • Frame/inner column finish is for under structure and inner/outer leg columns	29-1/2 x 46-1/2"	WU3048CB	<input type="checkbox"/>	<input type="checkbox"/>	<input type="checkbox"/>	<input type="checkbox"/>	<input type="checkbox"/>	109.0#	\$ 3090	\$ 3052	\$ 3175	\$ 27	\$ 178			
	29-1/2 x 52-1/2"	WU3054CB	<input type="checkbox"/>	<input type="checkbox"/>	<input type="checkbox"/>	<input type="checkbox"/>	<input type="checkbox"/>	115.0#	3172	3103	3281	27	178			
	29-1/2 x 58-1/2"	WU3060CB	<input type="checkbox"/>	<input type="checkbox"/>	<input type="checkbox"/>	<input type="checkbox"/>	<input type="checkbox"/>	122.0#	3189	3122	3297	27	178			
	29-1/2 x 64-1/2"	WU3066CB	<input type="checkbox"/>	<input type="checkbox"/>	<input type="checkbox"/>	<input type="checkbox"/>	<input type="checkbox"/>	128.0#	3255	3189	3421	27	178			
	29-1/2 x 70-1/2"	WU3072CB	<input type="checkbox"/>	<input type="checkbox"/>	<input type="checkbox"/>	<input type="checkbox"/>	<input type="checkbox"/>	134.0#	3270	3204	3434	27	178			

HOW TO ORDER

- Indicate the following information on order form:
- Quantity of each item.
 - Model number, including options. See "How To Build a Model Number".
 - Any special service required.

Note: • The indicates that a choice is required.
 • The absence of the indicates that no choice is required.
 • Alpha-numeric characters in place of indicate that no other alternatives are available.

HOW TO BUILD A MODEL NUMBER

- A** Select basic model.
- B** Select edge style.
74P - 74P edge
PL - Postformed edge
KN - Knife edge
 Knife edge (KN) and Postformed edge (PL) on user side only
- C** Select modesty panel.
NMP - No modesty panel
PMP - Polyester felt modesty panel; add \$203
- D** Select base option.
G - Glides
R - Rolling base (1 foot w/rollers, 1 foot w/glides); add \$60
- E** Select edge color.
 Refer to the **Product Color Options** page in this price list.
 Edge color offerings are based on edge style
- selections.
- F** Select surface finish.
 Refer to the **Product Color Options** page in this price list.
 Surface finish offerings are based on edge style selections.
- G** Select foot finish.
 Refer to the **Product Color Options** page in this price list.
- H** Select frame/inner column finish.
 Refer to the **Product Color Options** page in this price list.
- I** Select modesty panel color (only if polyester felt panel is chosen).
 Refer to the **Product Color Options** page in this price list.

SPECIAL SERVICES

Special Carton Marking
 With specially marked information N/C

Shipping
 Ships knocked down, FOB Bonduel, WI 54107, freight prepaid. Freight class 125.

Specifications and prices are subject to change without prior notice.

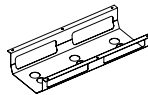
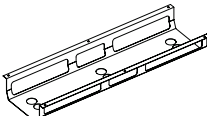
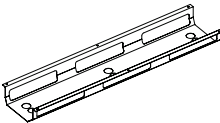

	MODEL	L	MODEL NUMBER		Approx. Packaged Weight	Delivered Pricing
			Basic Model	Paint Color		
 WUA01	Wire Trough • Keeps wires enclosed and tidy • Open design makes it easy to feed cables through trough • Steel construction • Intended for installation into pre-drilled pilot holes • Mounting hardware included • 9.5" wide x 4.2" high x 24" long • One kit for 48" rectangle and 24x36 corner table	24"	WU.TROUGH.48	<input type="checkbox"/>	5.00#	\$ 81
 WUA01	Wire Trough • Keeps wires enclosed and tidy • Open design makes it easy to feed cables through trough • Steel construction • Intended for installation into pre-drilled pilot holes • Mounting hardware included • 9.5" wide x 4.2" high x 36" long • One kit for 54" and 60" rectangle and 30x48 corner tables	36"	WU.TROUGH.60	<input type="checkbox"/>	7.00#	\$ 98
 WUA01	Wire Trough • Keeps wires enclosed and tidy • Open design makes it easy to feed cables through trough • Steel construction • Intended for installation into pre-drilled pilot holes • Mounting hardware included • 9.5" wide x 4.2" high x 48" long • One kit for 66" and 72" rectangle tables	48"	WU.TROUGH.72	<input type="checkbox"/>	10.00#	\$ 115

A

B

HOW TO ORDER

- Indicate the following information on order form:
- Quantity of each item.
 - Model number, including options. See "How To Build a Model Number".
 - Any special service required.

- Note:
- The indicates that a choice is required.
 - The absence of the indicates that no choice is required.
 - Alpha-numeric characters in place of indicate that no other alternatives are available.

HOW TO BUILD A MODEL NUMBER

- A** Select basic model.
- B** Select paint color. Refer to the **Product Color Options** page in this price list.

SPECIAL SERVICES

Special Carton Marking

With specially marked information N/C

Shipping

Ships **knocked down, FOB Bonduel, WI 54107, freight prepaid.** Freight class 125.

Specifications and prices are subject to change without prior notice.

Universal Height Adjustable Screens

General Information



Universal Height Adjustable Screens

General Information



Universal Height Adjustable Screen

Features	
Height adjustable by user	•
Material is 100% polyester felt	•
Only standard on select Pirouette fixed leg tables, WorkUp, and Toggle tables. Applications may be possible on other tables through Product Modification Requests. Contact Customer Service for details.	•
Field-installed	•

Adjustable Privacy Screens attach to the back length of a table or to the side depth of a table.

Screen Size (W x H)	Recommended for:
23 x 24	24" deep tops
29 x 24	30" deep tops
35 x 24	36" deep tops
46 x 24	48" long tops
52 x 24	54" long tops
58 x 24	60" long tops
64 x 24	66" long tops
70 x 24	72" long tops
82 x 24	84" long tops

The screens are standard for a variety of models on Pirouette, Toggle and WorkUp tables. These particular tables include pilot holes for mounting the screens to the undersides of the worksurfaces. Reference the following for table models within these products that include and exclude the screen pilot holes:

YES	NO
Toggle Rectangles and Square Shoe	Toggle 120 Degree
WorkUp Rectangles	WorkUp 120 Degree
Pirouette Fixed Training Rectangles	Pirouette Collaborative Rectangles
Pirouette Fixed Chevrons (Straight Side Only)	Pirouette 42" & 48" Deep Rectangles
	Pirouette Nesting Tables
	Pirouette Scale Up Tables
	Pirouette Half Rounds
	Pirouette Trapezoids
	Pirouette Double Chevrons
	Pirouette Guitar Picks
	Pirouette Squares
	Pirouette Rounds

SPECIFICATIONS

Screen

Screens are constructed from a sound-absorbing, 100% polyester felt with an acoustic rating of 0.45-0.90 NRC. The screen is 1/2" thick with a density of .05 lb/ft and is 100% tackable. Screens are in accordance with ASTM-E84 and achieve a Class A Flame Spread. Standard screens are 23.75" high by 23", 29", 35", 46", 52", 58", 64", 70" and 82" wide.

Brackets

The mounting brackets are 14-gauge cold rolled steel and the glide plates are injected molded Delrin. The rack is made from cast aluminum and a nylon pinion gear is synchronized between the brackets with a steel connecting rod. The mounting brackets and rack are powder coated for durability. The PET screens are fastened to the brackets using stainless steel thumb screws (two per bracket). Screen sizes 23", 29", 35", and 46" wide are assembled with two adjustable brackets while screens 52", 58", 64", 70" and 82" have three adjustable brackets.

INFORMATION

Warranty

Refer to KI Terms & Conditions document or visit ki.com

**Base Finish**

Black	BL
Blue Grey	GR
Bronze Metallic	ZM
Cayenne	CY
Champagne Metallic	CM
Cool Grey	CG
Cottonwood	CO
Earthen Clay	EY
Espresso Metallic	EX
Everglade Shade	EV
Flannel	FN
Glitz Metallic	GZ
Hazy Jade	HJ
Honey Bee	HY
Light Tone	LG
Mardi Gras	MG
Misty Brown	MY
Nemo	NE
Nordic	ND
Purple Haze	PH
Rainforest	RQ
Raw Jasper	RJ
Rubber Ducky	RK
Sand	SA
Starlight Silver Metallic	SX
Surf's Up	SP
Tarragon	TQ
Toggle Black	TGBL
Toggle Silver	TGSL
Toggle White	TGWH
Twilight Shadow	TI
Ultra Blue	UB
Warm Grey	WG
Zesty Lime	ZL

Felt Color

Dandelion	FTDD
Fawn	FTFW
Flannel	FTFN
Heather	FTHR
Lava	FTLV
Mallard	FTML
Midnight Blue	FTMB
Pepper	FTPR
Spring	FTSG
Tidal Wave	FTTW

Finish Cards

View color swatches for items listed within this document.

Paints**Plastics/Poly****Wood/Veneer****Laminates****Molded Edges****Edge Styles****Hard Plastics****Glass**

Certain options referenced may not be available on GSA Schedule.

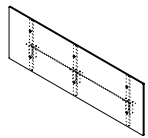

MODEL	W x H	MODEL NUMBER			Approx. Packaged Weight	Delivered Pricing
		Basic Model	Base Finish	Felt Color		
 <p>Universal Height-Adjustable Screens - Felt, 24" Tall</p> <ul style="list-style-type: none"> • Height adjustable by user • Screen is flush with tabletop when at its lowest position • Maximum height above worksurface 17" • Screens attach to either the back length or side depth of tabletop based on closest nominal size • Monitor arms, modesty panels, and wire troughs may prohibit installation of screens • Screens are standard on select Pirouette, Toggle, and WorkUp tables (refer to chart on General Information page) 	23 x 24"	USPF2324	<input type="checkbox"/> <input type="checkbox"/> <input type="checkbox"/> <input type="checkbox"/>	<input type="checkbox"/> <input type="checkbox"/> <input type="checkbox"/> <input type="checkbox"/>	7.0#	\$ 668
	29 x 24"	USPF2924	<input type="checkbox"/> <input type="checkbox"/> <input type="checkbox"/> <input type="checkbox"/>	<input type="checkbox"/> <input type="checkbox"/> <input type="checkbox"/> <input type="checkbox"/>	8.0#	703
	35 x 24"	USPF3524	<input type="checkbox"/> <input type="checkbox"/> <input type="checkbox"/> <input type="checkbox"/>	<input type="checkbox"/> <input type="checkbox"/> <input type="checkbox"/> <input type="checkbox"/>	8.0#	737
	46 x 24"	USPF4624	<input type="checkbox"/> <input type="checkbox"/> <input type="checkbox"/> <input type="checkbox"/>	<input type="checkbox"/> <input type="checkbox"/> <input type="checkbox"/> <input type="checkbox"/>	9.0#	773
	52 x 24"	USPF5224	<input type="checkbox"/> <input type="checkbox"/> <input type="checkbox"/> <input type="checkbox"/>	<input type="checkbox"/> <input type="checkbox"/> <input type="checkbox"/> <input type="checkbox"/>	11.0#	849
	58 x 24"	USPF5824	<input type="checkbox"/> <input type="checkbox"/> <input type="checkbox"/> <input type="checkbox"/>	<input type="checkbox"/> <input type="checkbox"/> <input type="checkbox"/> <input type="checkbox"/>	12.0#	1081
	64 x 24"	USPF6424	<input type="checkbox"/> <input type="checkbox"/> <input type="checkbox"/> <input type="checkbox"/>	<input type="checkbox"/> <input type="checkbox"/> <input type="checkbox"/> <input type="checkbox"/>	12.0#	1096
	70 x 24"	USPF7024	<input type="checkbox"/> <input type="checkbox"/> <input type="checkbox"/> <input type="checkbox"/>	<input type="checkbox"/> <input type="checkbox"/> <input type="checkbox"/> <input type="checkbox"/>	13.0#	1110
82 x 24"	USPF8224	<input type="checkbox"/> <input type="checkbox"/> <input type="checkbox"/> <input type="checkbox"/>	<input type="checkbox"/> <input type="checkbox"/> <input type="checkbox"/> <input type="checkbox"/>	14.0#	1162	
			A	B	C	

USPF

HOW TO ORDER

- Indicate the following information on order form:
1. Quantity of each item.
 2. Model number, including options. See "How To Build a Model Number".
 3. Any special service required.

Note:

- The indicates that a choice is required.
- The absence of the indicates that no choice is required.
- Alpha-numeric characters in place of indicate that no other alternatives are available.

HOW TO BUILD A MODEL NUMBER

- A** Select basic model.
- B** Select base finish.
Refer to the **Product Color Options** page in this price list.
- C** Select felt color.
Refer to the **Product Color Options** page in this price list.

SPECIAL SERVICES

Special Carton Marking

With specially marked information N/C

Shipping

Ships **assembled, FOB Bondue, WI 54107, freight prepaid.** Freight class 70.

Specifications and prices are subject to change without prior notice.

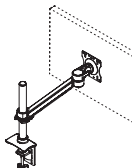
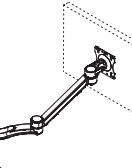

MODEL	Features	MODEL NUMBER		Approx. Packaged Weight	Delivered Pricing
		Basic Model			
 <p>AC200</p> <p>12" Post, Single Screen, 10" Arm</p> <ul style="list-style-type: none"> 12" post with table-edge mount or grommet mount 10" arm with one wire management clip 10" arm has integrated wire management channel and cover Swivel/tilt adapter plate for 75 & 100mm hole patterns Supports one 14 lb. flat screen monitor Can be used on both freestanding tables and panel-mounted worksurfaces 360° swivel movement allows monitor to rotate from landscape to portrait orientation Pole allows manual height adjustment through a 9" range to accommodate user preference Includes parts for either clamp or grommet mount Monitor is not included 	Silver finish	CFS03.SL	7.00#	\$ 331	
	White finish	CFS03.WH	7.00#	331	
	Black finish	CFS03.BL	7.00#	331	
 <p>AC200</p> <p>12" Post, Single Screen, Height-Adjustable Double Extension Arm</p> <ul style="list-style-type: none"> 12" post with table-edge mount or grommet mount One 10" arm and one 9" arm with two wire management clips 10" arm has integrated wire management channel and cover Swivel/tilt adapter plate for 75 & 100mm hole patterns Supports one 14 lb. flat screen monitor Can be used on both freestanding tables and panel-mounted worksurfaces 360° swivel movement allows monitor to rotate from landscape to portrait orientation Pole allows manual height adjustment through a 9" range to accommodate user preference Includes parts for either clamp or grommet mount Monitor is not included 24" of forward/backward movement Arm folds back to post to maximize desk space 	Silver finish	CFS04.SL	9.00#	\$ 403	
	White finish	CFS04.WH	9.00#	403	
	Black finish	CFS04.BL	9.00#	403	

A

HOW TO ORDER

- Indicate the following information on order form:
- Quantity of each item.
 - Model number, including options. See "How To Build a Model Number".
 - Any special service required.

Note:

- The indicates that a choice is required.
- The absence of the indicates that no choice is required.
- Alpha-numeric characters in place of indicate that no other alternatives are available.

HOW TO BUILD A MODEL NUMBER

A Select basic model.

SPECIFICATIONS

Tilt +1/-90°
 Swivel +1/-180
 Rotation +/-180
 Worksurface Range 0-3.5" for table edge mount
 Material - Steel and aluminum

Warranty - These products are warranted as follows: Lifetime
 Monitor - These products are not included.

SPECIAL SERVICES

Special Carton Marking

With specially marked information N/C

Shipping
 Ships assembled, FOB Manitowoc, WI 54220, freight prepaid. Freight class 70.

Specifications and prices are subject to change without prior notice.



MODEL	Features	MODEL NUMBER		Approx. Packaged Weight	Delivered Pricing
		Basic Model			
12" Post, Dual Screen, Two 10" Arms • 12" post with table-edge mount or grommet mount • Two 10" arms with two wire management clips • Arms have integrated wire management channel and cover • Two swivel/tilt adapter plates for 75 & 100mm hole patterns • Supports two 20 lb. flat screen monitors with a maximum width of 23.7" per screen • Can be used on both freestanding tables and panel-mounted worksurfaces • 360° swivel movement allows monitor to rotate from landscape to portrait orientation • Pole allows manual height adjustment through a 11" range to accommodate user preference • Includes parts for either clamp or grommet mount • Monitors are not included • Monitors adjust in unison to maintain a level plane and provide consistent vision line	Silver finish	CFS05.SL	10.00#	\$ 633	
	White finish	CFS05.WH	10.00#	633	
	Black finish	CFS05.BL	10.00#	633	

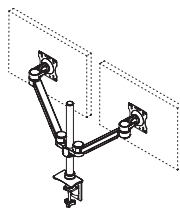

AC200

A

HOW TO ORDER

- Indicate the following information on order form:
- Quantity of each item.
 - Model number, including options. See "How To Build a Model Number".
 - Any special service required.

Note:

- The indicates that a choice is required.
- The absence of the indicates that no choice is required.
- Alpha-numeric characters in place of indicate that no other alternatives are available.

HOW TO BUILD A MODEL NUMBER

A Select basic model.

SPECIFICATIONS

Tilt +1/-90°
 Swivel +1/-180
 Rotation +/-180
 Worksurface Range 0-3.5" for table edge mount
 Material - Steel and aluminum

Warranty - These products are warranted as follows: Lifetime
 Monitor - These products are not included.

SPECIAL SERVICES

Special Carton Marking

With specially marked information N/C

Shipping

Ships **assembled, FOB Manitowoc, WI 54220, freight prepaid.** Freight class 70.

Specifications and prices are subject to change without prior notice.



MODEL	Features	MODEL NUMBER		Approx. Packaged Weight	Delivered Pricing
		Basic Model			
12" Post, Dual Screen, Two Double Extension Arms <ul style="list-style-type: none"> • 12" post with table-edge mount or grommet mount • Two 10" arms and two 9" arms (one 10" and one 9" arm per monitor) with four wire management clips • 10" arms have integrated wire management channel and cover • Two swivel/tilt adapter plates for 75 & 100mm hole patterns • Each extended arm supports one 14 lb. flat screen monitor • Maximum monitor size is 36" • Can be used on both freestanding tables and panel-mounted worksurfaces • 360° swivel movement allows monitor to rotate from landscape to portrait orientation • Pole allows manual height adjustment through a 9" range to accommodate user preference • Includes parts for either clamp or grommet mount • Monitors are not included • 24" of forward/backward movement • Arm folds back to post to maximize desk space • Monitors adjust in unison to maintain a level plane and provide consistent vision line 	Silver finish	CFS06.SL	11.00#	\$ 787	
	White finish	CFS06.WH	11.00#	787	
	Black finish	CFS06.BL	11.00#	787	

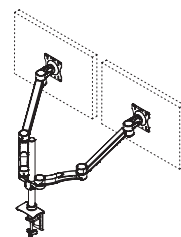

AC200

A

HOW TO ORDER

- Indicate the following information on order form:
1. Quantity of each item.
 2. Model number, including options. See "How To Build a Model Number".
 3. Any special service required.

Note:

- The indicates that a choice is required.
- The absence of the indicates that no choice is required.
- Alpha-numeric characters in place of indicate that no other alternatives are available.

HOW TO BUILD A MODEL NUMBER

A Select basic model.

SPECIFICATIONS

Tilt +1/-90°
 Swivel +1/-180
 Rotation +/-180
 Worksurface Range 0-3.5" for table edge mount
 Material - Steel and aluminum

Warranty - These products are warranted as follows: Lifetime
 Monitor - These products are not included.

SPECIAL SERVICES

Special Carton Marking

With specially marked information N/C

Shipping
 Ships assembled, FOB Manitowoc, WI 54220, freight prepaid. Freight class 70.

Specifications and prices are subject to change without prior notice.



1330 BELLEVUE STREET
GREEN BAY, WI 54302
800.424.2432 / KI.COM

KI is a trusted expert for furniture and wall systems around the globe.
USA | CANADA | MEXICO | UK | EUROPE | ASIA | MIDDLE EAST
© 2026 Krueger International, Inc. All Rights Reserved.