

WOODWORKS® Linear

Veneered Open



FAST134
 Select Items Ship Fast
armstrongceilings.com/fast134

CAD/Revit® drawings at:
armstrongceilings.com/cadrevit

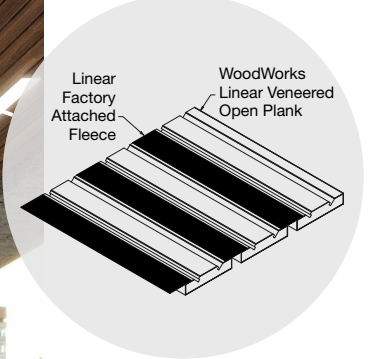

WoodWorks® Linear Veneered Open 3-3/4" planks in Plain Slice Walnut (NWN)

Standard, easy-to-install wood veneer planks offer a variety of installation options.

KEY SELECTION ATTRIBUTES



- Standard veneers feature various species and cuts for beautiful wood visuals
- Standard wood planks in two widths; nominal 4-1/2" and 6" O.C. plank modules with 3/4" reveal
- Standard factory-applied acoustic fleece
- The natural warmth of wood can contribute to biophilic designs and building certification standards like the WELL™ v2 "Nature and Place" feature
- Installation options including: ceiling, wall (horizontal only), ceiling-to-wall at 90° transition, or ceiling-to-wall with a faceted curved transition
- Select products included in the FAST134 program – ready to ship in 4 weeks or less
- Complete standard system from one manufacturer, including suspension system, panels, and trim options
- USDA Biobased content: 100%
- FSC® certified wood available as a premium quoted option (FSC® C007626)
- CleanAssure™ family of products – includes disinfectable panels, suspension systems, and trim
- Made in the U.S.A. of domestic and global content
- Build America, Buy America (BABA) Act compliant

VENEER CUTS

Different cuts of a log will yield different graining visuals. Choose your veneer to achieve your desired look.

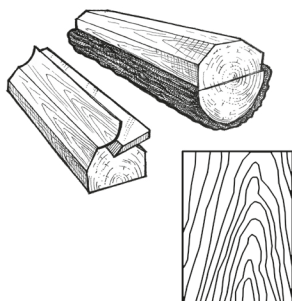

Plain Sliced
 Produces the well known cathedral or loop-grain effect.

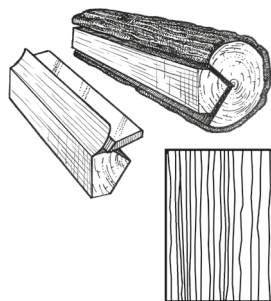

Quarter Sliced
 Produces a striped, often straight-grain effect.

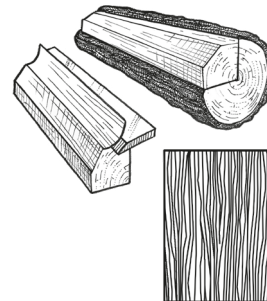

Rift Sliced
 Produces a tight, linear grain along the entire length of the veneer.

WOODWORKS® Linear

Veneered Open

RECYCLED
CONTENT

LEED V5

UP TO
80%

USDA
CERTIFIED
BIOBASED
PRODUCT
PRODUCT 100%

COMMON MATERIALS FRAMEWORK		Climate Health	EPD
Human Health		Ecosystem Health	EPD
		Circular Economy	FSC
OCCUPANT EXPERIENCE		Acoustics	✓

FINISH RANGES

The carefully curated species and veneer cuts offer a beautiful natural variation. The images here reflect the visual range that is likely within our product. Darkest to lightest tones may occur within an installation due to the character of wood.



Plain Slice White Maple (NWM)



Plain Slice White Ash (NWA)



Vertical Grain Fir (NVF)



Rift White Oak (NRO)

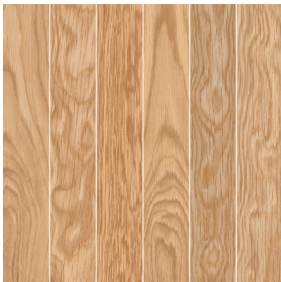

Plain Slice White Oak (NOK)



Plain Slice Cherry (NPC)



Quartered Mahogany (NGM)



Quartered Sapele (NGS)



Quartered Walnut (NQW)



Plain Slice Walnut (NWN)

CUSTOM FINISHES



Custom Wood
Species and Finishes
Available

LEGACY VENEERS

Natural Variations™
Plain Slice

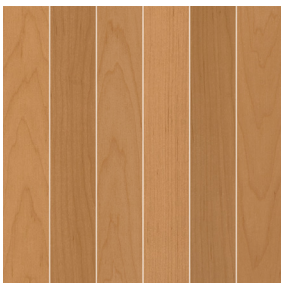

Maple (NMP)



Light Cherry (NLC)

Constants™
Vertical Grain

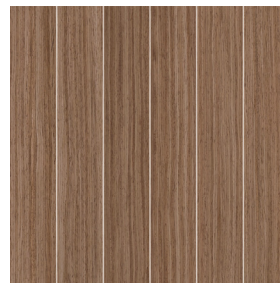

Walnut (CWA)



Redux Wood Wheat (CRW)

Due to printing limitations, shade may vary from actual product.



WOODWORKS® Linear

Veneered Open

RECYCLED
CONTENT

LEED V5

UP TO
80%

COMMON MATERIALS FRAMEWORK

Climate Health

EPD

Human Health

Ecosystem Health

EPD

FSC

Circular Economy

✓

OCCUPANT EXPERIENCE

Acoustics

✓

USDA
CERTIFIED
BIOBASED
PRODUCT
PRODUCT 100%

VISUAL SELECTION

Item No. ◆	Description	Dimensions W x L x H (Inches)	LBS/SF
WoodWorks® Linear Veneered Open 6440F01W1_ _ _	4-1/2" O.C. Plank	3-3/4 x 96 x 3/4" with 3/4" reveal	2.75
6460F01W1_ _ _	6" O.C. Plank	5-1/4 x 96 x 3/4" with 3/4" reveal	2.75

FAST
4 WEEKS
or Less

FAST134 program items ready to ship from manufacturer in 4 weeks or less. Up-to-date lead times and product options (sizes and colors) at armstrongceilings.com/fast134

Item No. ◆	Description	Dimensions W x L x H (Inches)	LBS/SF
WoodWorks Linear Veneered Open FSC® certified* 6440F02W1_ _ _	4-1/2" O.C. Plank	3-3/4 x 96 x 3/4" with 3/4" reveal	2.75
6460F02W1_ _ _	6" O.C. Plank	5-1/4 x 96 x 3/4" with 3/4" reveal	2.75



◆ When specifying or ordering, include the appropriate 3-letter color suffix (e.g. 6440F01W1 N M P)
* FSC-certified wood is a premium option available through ASQuote@armstrong.com

PERFORMANCE

Dots represent high level of performance.

CleanAssure™ Disinfectable Panels		
Fog	Spray	Wipe
•	•	•

ACOUSTICAL

Infill Panel Item No.	NRC	CAC
3-3/4" Panel Only	0.50	-
8200T10	0.60	-
1713BL	0.45	37
2820BK	0.55	36
5823	0.60	23
5479	0.60	23
1318	0.55	32
5-1/4" Panel Only	0.40	-
8200T10	0.45	-
1713BL	0.35	38
2820BK	0.45	38
5823	0.50	26
5479	0.50	26
1318	0.40	34

ACCESSORIES

	Item No. ◆	Description	Dimensions Nominal W x L x H (inches)	Color	PCS/CTN
Suspension Systems	5370	12" HD Linear Carriers (concealed) with integral clips (factory-applied) for nominal 4-1/2" modules	15/16 x 144 x 1-11/16"	Black	10 (Approx. 240 SF/CTN installed with planks)
	5371	12" HD Linear Carriers (concealed) with integral clips (factory-applied) for nominal 6" modules	15/16 x 144 x 1-11/16"	Black	10 (Approx. 240 SF/CTN installed with planks)
	XL7328BL	Prelude® XL® 2' Cross Tee (for discontinuous / cloud applications)	15/16 x 24 x 1-3/8"	Black	60
	7805	1-1/2" Angle Molding	1-1/2 x 120 x 1-1/2"	White or Black	30
	7823	Shadow Molding (Seismic)	7/8 x 144 x 7/8"	White	30
	7891	12-Gauge Hanger Wire	144" Length	Mill Finish	140
	Accessories	7100	Heavy-duty Wall Anchor (Seismic)	1-1/4 x 3 x 1"	Mill Finish
BERC2		Beam End Retaining Clip	N/A	Mill Finish	200
5373		WoodWorks Linear Veneered Open Grid Tee Snap-in Clip	N/A	N/A	100
7425		Stabilizer Bar	24" Length	Mill Finish	100
5843		Linear Wood Panel Splice	N/A	N/A	100
RC2BL		Radius Clip for faceted grid applications (Black)	N/A	N/A	205 PCS/bucket
6459BL		Rigid Attachment Clip (Black)	1-1/2 x 4-1/2 x 1-3/4"	N/A	25
Acoustical Infill Panels		5823	BioAcoustic™ Infill Panel	24 x 24 x 5/8"	Black Matte
	1713BL	School Zone® Fine Fissured™ Square Lay-in Panel	24 x 24 x 3/4"	White or Black	12
	1318	Backstage Noir® Square Lay-in Panel	24 x 24 x 3/4"	Black	12
	8200T10	Fiberglass Infill Panel	24 x 24 x 1"	Black Gloss	12
	2820BK	Calla® Square Lay-in Panel	24 x 24 x 7/8"	Black	10
Perimeter Trim	6481F01W1H_ _ _	4", 6", 8" Veneered Trim with 4 Clips - Item 5925 (With Faux Wood Edgebanding on Long Edges)	96" x 3/4"	All Veneers	N/A
	5925	Replacement Trim Clips	N/A	Mill Finish	25
	7239	Adjustable Trim Clip	N/A	Mill Finish	50
	AXSJ	Axiom® Slip Joint	2 x 120 x 2-1/4"	N/A	10 LF
	AX_VESTR_ _ _	Axiom Vector Straight Trim - Recommend in Black 6" and up	N/A	Silver Grey, Black, Gun Metal	10 LF
	AX_VECUR_ _ _	Axiom Vector Curved Trim - Recommend in Black 6" and up	N/A	Silver Grey, Black, Gun Metal	10 LF
	6408_ _ _	WoodWorks Edgebanding Coordinating Faux Wood	3/4" x 300"	All Veneers	25 LF

When ordering suspension system materials, please note that this product requires Prelude® XL® HD (Heavy-duty) 15/16" main beams and 2' cross tees that are full height (1-11/16"). Both suspension system components should be specified in Tech Black (BL).

◆ When specifying or ordering, include the height (4, 6, or 8) and 3-letter veneer suffix that coordinates with your WoodWorks ceiling (e.g. 6481F01W1H 4 N W M).
NOTE: Refer to installation instructions at armstrong.com/installation for a better understanding of suspension system requirements.

TechLine 877 276-7876

armstrongceilings.com/woodworkslinear

Armstrong®
World Industries

WOODWORKS® - Standard



WOODWORKS® Linear

Veneered Open

RECYCLED
CONTENT

LEED V5

UP TO
80%

USDA
CERTIFIED
BIOBASED
PRODUCT
PRODUCT 100%

COMMON MATERIALS FRAMEWORK

Human Health

Circular Economy

OCCUPANT EXPERIENCE

Climate Health

Ecosystem Health

Acoustics

EPD

EPD

FSC

✓

SYSTEM INSTALLATION DETAILS

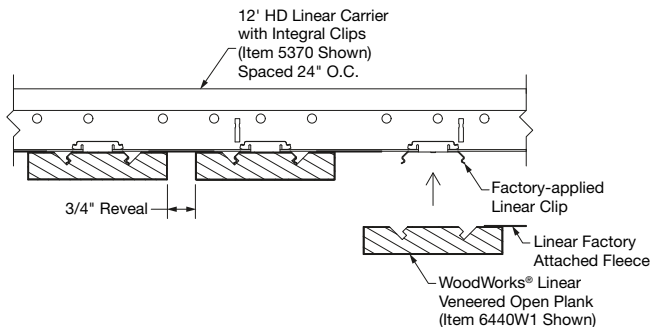

1 Linear Veneered Open Plank to Grid Install

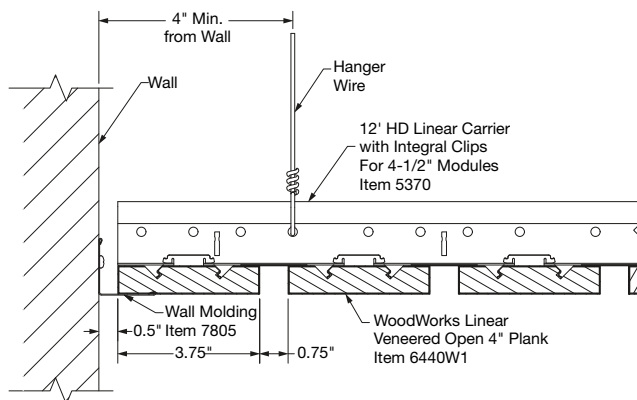

2 Linear Veneered Open Wall Perimeter Detail

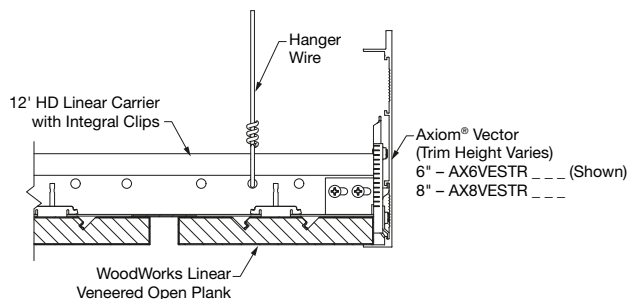

3 Axiom® Perimeter Trim

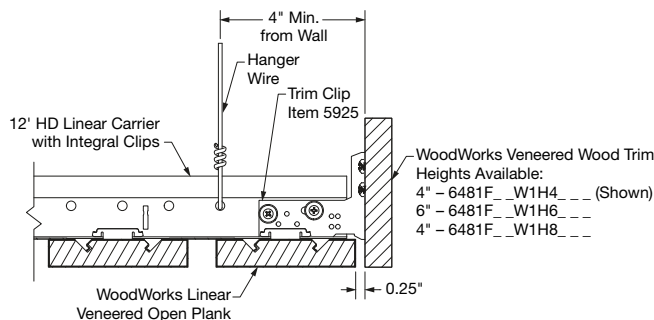

4 Veneered Perimeter Trim

PHYSICAL DATA

Material

Fire-rated particle board (FRPB) with real wood veneers. Vertical Grain Fir (NVF) is FRPB with a reconstituted veneer. Factory-applied black fleece on each plank to cover the reveal.

Surface Finish

Clear or tinted semi-gloss coating

Fire Performance

Class A: ASTM E84 surface burning characteristics. Flame Spread Index 25 or less. Smoke Developed Index 50 or less.

CAN/ULC S102 surface burning characteristics.

Flame Spread Rating 25 or less. Smoke Developed Classification 50 or less.

Linear wood, as with other architectural features located at the ceiling, may obstruct or skew the planned fire sprinkler water distribution pattern, or possibly delay or accelerate the activation of the sprinkler or fire detection systems by channeling heat from a fire either toward or away from the device. Designers and installers are advised to consult a fire protection engineer, NFPA 13, and local codes for guidance where automatic fire detection and suppression systems are present.

ASTM E1264 Classification
Type XX; Pattern: Z; Class A

Application Considerations

Variation among panels may occur due to the natural characteristics of the wood and grain. It is very important that WoodWorks planks are climatized prior to installation. Relative humidity between 25% and 55%, and temperatures between 50°F and 86°F, must be maintained.

Specification Consideration

Attention: For FSC-certified wood products to maintain their CoC certification, products must be sold to a CoC certified distributor or directly to the installing contractor. Failure to do so breaks the CoC.

Installation Considerations

Installation can use staggered, random joints for a monolithic appearance or consistent lengths for a modular style. For expansion, a 3/4\"/>

Design & Pre-Construction Service

For complimentary design and pre-construction assistance, contact ProjectWorks® or visit armstrong.com/projectworks

Seismic Restraint

WoodWorks Linear Veneered Open planks have been engineered, tested, and approved for application in all seismic areas when installed per Armstrong installation instructions.

Cleaning and Disinfecting

Cleaning and CDC-approved disinfecting options available on armstrong.com/cleaning

FAST134 Program Considerations

Size of Job Matters: Big jobs, over 2500 SF or 50 pieces for shapes/vertical elements will have longer lead times.

Location Matters: Transit time not included. We are ready to ship in 1 week on FAST1 items. However, transit to the states west of Wyoming may add time.

Distributor Truck Schedule Matters: We rely on distribution to help move products around the country. When speed matters, work with your local distributor to ensure FAST134 service.

Stock vs. Made-to-Order Matters: FAST3 & FAST4 items are made-to-order and will ship direct to distributor. FAST1 (stocked items) will go through distribution and depend on distributor truck schedules.

Warranty

Warranty details at armstrong.com/warranty

Weight

Refer to visual selection chart (Bulk packaged)