

USG Exterior Ceiling Systems

SYSTEMS GUIDE



IT'S YOUR WORLD. BUILD IT.®

USG EXTERIOR CEILING SYSTEMS

SYSTEMS GUIDE

For decades, USG exterior ceiling systems have been utilized in a wide variety of exterior applications because they not only satisfy stringent performance requirements and design criteria but also provide beauty and durability.

Introduction	4	SYSTEMS OVERVIEW Exterior Ceiling Applications Performance Selector
Exterior Ceiling Applications	9	LINEAR METAL CEILING SYSTEMS Paraline® II Paraline® Plus Planx™ Universal
	34	METAL PANEL CEILING SYSTEMS Celebration™ Snap-In Celebration™ Torsion Spring
	48	LAY-IN PANELS USG Sheetrock® Brand Gypsum Lay-In Panels (GLIP)
	54	CONTINUOUS CEILINGS USG Sheetrock® Brand Drywall with USG Drywall Suspension System (DWSS)
Other Considerations	56	Finishes Compression Posts Seismic Perimeter Applications
For More Information		Technical Service: 800.USG.4YOU Website: usg.com

USG EXTERIOR CEILING SYSTEMS

SYSTEMS GUIDE

Ceiling Product Data Sheets

LINEAR METAL CEILING SYSTEMS

[Paraline® II](#)

[Paraline® Plus](#)

[Planx™ Universal](#)

METAL PANEL CEILING SYSTEMS

[Celebration™ Snap-In](#)

[Celebration™ Torsion Spring](#)

LAY-IN PANELS

[USG Sheetrock® Brand Gypsum Lay-In Panels \(GLIP\)](#)

CONTINUOUS CEILINGS

[USG Sheetrock® Brand Drywall with USG Drywall Suspension System \(DWSS\)](#)

SYSTEMS OVERVIEW

Exterior Ceiling Applications

INTRODUCTION

USG provides seven systems for use in exterior environments that are not directly exposed to the weather, such as under soffits, parking garages, covered entrances, or drive-throughs:

- Paraline® II Linear Metal Ceiling System
- Paraline® Plus Linear Metal Ceiling System
- Planx™ Universal Linear Metal Panel System
- Celebration™ Snap-In Metal Panel Ceiling System¹
- Celebration™ Torsion Spring Metal Panel Ceiling System
- ZXLA™ with USG Sheetrock® Brand Lay-In Ceiling Panel
- USG Drywall Suspension System

These ceiling systems combine traditional modules, elegant linear pans, or metal panels with a specially engineered suspension system to create dynamic ceilings featuring clean, contemporary planes.

This guide covers flat ceilings attached to perimeter walls on all sides. installed per ASTM C636. For other installations including sloped or curved ceilings consult USG architectural Representative.

These guidelines outline the design considerations, test results, and construction details for the installation of each USG exterior ceiling system. USG exterior assemblies were tested per UL 580, UL 1897, TAS 202, and TAS 203.

For more information about UL Standards, please visit www.UL.com.

For more information about Florida Building Code Testing Application Standards (TAS), please visit www.floridabuilding.org.



¹ USG Celebration™ Snap-In system appropriate for exterior ceiling applications.

SYSTEMS OVERVIEW

Exterior Ceiling Applications

WIND DESIGN NOTES

Miles Per Hour (mph) versus Pounds Per Square Foot (psf)

ASCE 7-22, Minimum Design Loads for Buildings and Other Structures, American Society of Civil Engineers/Structural Engineering Institute (ASCE/SEI), contains a formula that converts wind speed into static pressure. The formula is a comprehensive approach to include factors such as height or location of the building or directionality of wind loads affecting the structure expressed as:

$$q_z = 0.00256 K_z K_{zt} K_e V^2$$

q_z = velocity pressure evaluated at height z above the ground (psf)

K_z = velocity pressure exposure coefficient

K_{zt} = topographic factor

K_e = ground elevation factor

V = basic wind speed (mph)

All the test results presented in this guide were achieved by measuring the maximum pressure that the system can withstand. The formula above provides guidance on how to estimate the wind speed correlating to the particular pressure. Because the factors (K_z , K_{zt} , K_e) are project specific, they were assumed to be equal to one. Therefore, the simplified formula to estimate wind speed based on given pressures is as follows:

$$V = \sqrt{q_z / 0.00256}$$

Wind load provisions of ASCE 7-22 are recognized in the 2024 International Residential Code (IRC) and the 2024 International Building Code (IBC). The information presented is correct to the best of our knowledge at the date of issuance. Because codes continue to evolve, check with a local official prior to designing and installing a ceiling system. Other restrictions and exemptions may apply.

WIND PRESSURE TEST METHODS

USG exterior assemblies were tested for both uplift (positive) and downward (negative) pressures. The positive values represent uplift capacity and the negative values represent downward capacity. Testing for both positive and negative pressures offers a more complete assessment of the performance of USG assemblies. It also allows USG to evaluate and certify the comparative resistance of USG assemblies to both positive and negative pressures. With the publication of this thorough wind load assessment, design professionals can be assured USG exterior assemblies satisfy the most stringent performance requirements and design criteria.

PRODUCT SELECTOR

Linear Metal Ceiling Systems

PARALINE® II (See page 11)

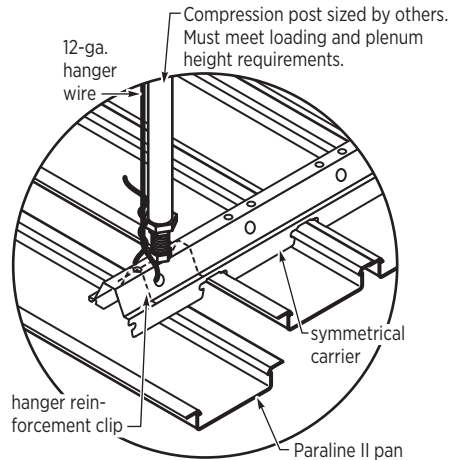

- One part system - pans with integral closed reveal.
- Pans can be removed for plenum access.
- 3-1/4" wide pans, 3/4" integral closed reveal, 12' long pans.

PRODUCT PERFORMANCE RANGES

Pressure psf (kPa)		Wind speed mph (Kph)
Up	Down	
46 to 102 (2.20 to 4.88)	-106 (-5.08)	135 to 200 (217 to 322)

STANDARD PAINTED METALS



PARALINE® PLUS (See page 11)

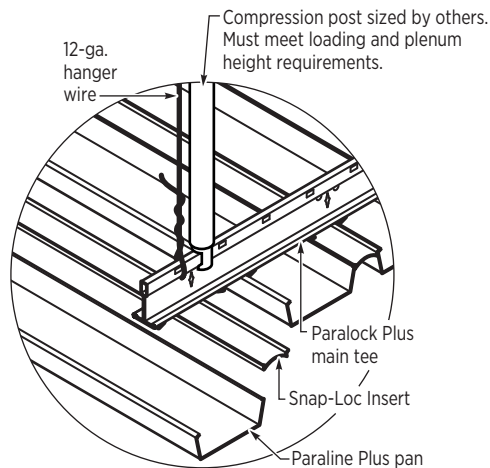

- 2 part system - pans with Snap-Loc inserts to close reveal between pans.
- Snap-Loc inserts and pans can be removed for plenum access.
- 3", 7" & 11" wide, 1" reveal, 12' long pans.
- Approved for installation in seismic category C, D, E, & F.
- Notice of Acceptance (NOA) issued by Miami Dade County.

PRODUCT PERFORMANCE RANGES

Pressure psf (kPa)		Wind speed mph (Kph)
Up	Down	
30 to 127 (1.44 to 6.08)	-25 to -38 (-1.20 to -1.82)	98 to 222 (158 to 357)

STANDARD PAINTED METALS

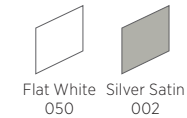

ANODIZED METALS



TIMBRE™

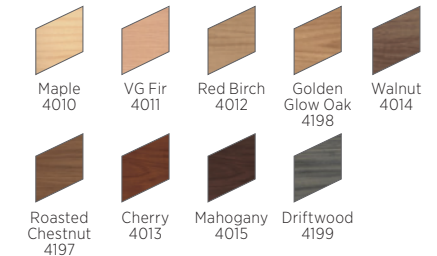

PRODUCT SELECTOR

Linear Metal Ceiling Systems

**PLANX™ UNIVERSAL -
OPTIONAL REVEAL**
(See page 11)

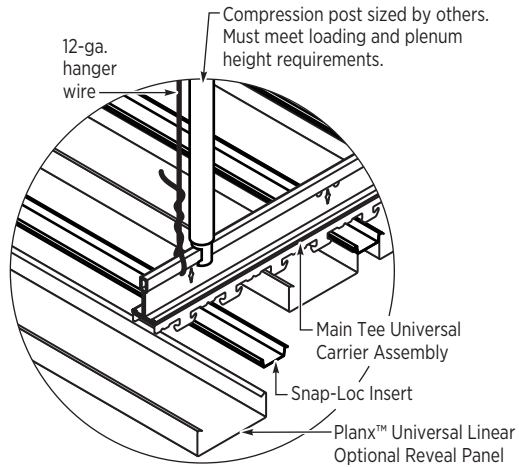

- 2-part system - Aluminum panels with Snap-Loc inserts to close reveal between panels.
- Snap-Loc inserts and panels can be removed for plenum access.
- 4", 6", 8", 10" & 12" modular width, 15/16" reveal, 12' long panels.
- ICC-ES ESL-1652 issued for exterior applications.

PRODUCT PERFORMANCE RANGES

Pressure psf (kPa)		Wind speed mph (Kph)
Up	Down	
103 (4.91)	-77 (-3.68)	173 to 200 (279 to 322)

STANDARD PAINTED METALS



SARANTE™ Premium Finishes



TIMBRE™

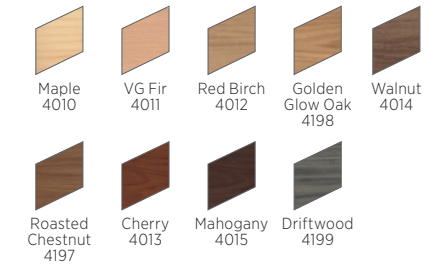

PRODUCT SELECTOR

Linear Metal Ceiling Systems

PLANX™ UNIVERSAL - INTEGRAL REVEAL (See page 11)

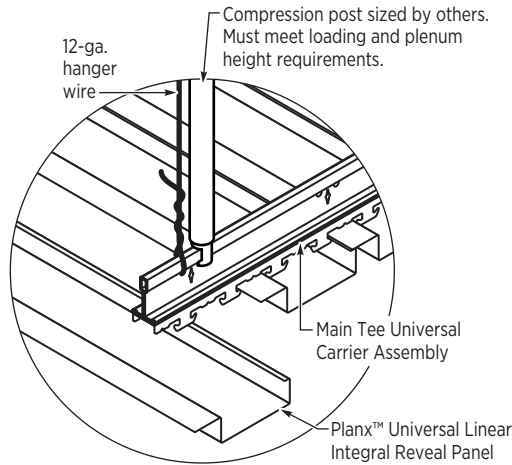

- One part system - Aluminum panels with integral closed reveal.
- Panels can be removed for plenum access.
- 4", 6", 8" & 10" modular width, 15/16" integral closed reveal, 12' long panels.
- ICC-ES ESL-1652 issued for exterior applications.

PRODUCT PERFORMANCE RANGES

Pressure psf (kPa)		Wind speed mph (Kph)
Up	Down	
	-73 (-3.48)	168 (271)

REFER TO PAGE 7 FOR ALL PLANX™ UNIVERSAL FINISHES

PLANX™ UNIVERSAL - NO REVEAL (See page 11)

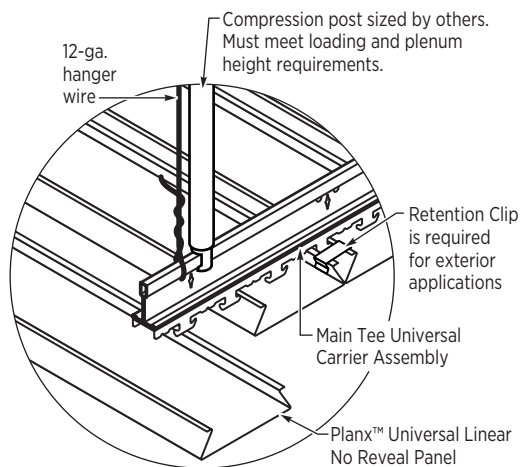

- One part system - Aluminum panels with no reveal (monolithic appearance).
- Panels can be removed for plenum access.
- 4", 6", 8" & 10" wide, with no reveal, 12' long panels.
- ICC-ES ESL-1652 issued for exterior applications.

PRODUCT PERFORMANCE RANGES

Pressure psf (kPa)		Wind speed mph (Kph)
Up	Down	
	-51 (-2.46)	142 (228)

REFER TO PAGE 7 FOR ALL PLANX™ UNIVERSAL FINISHES

PRODUCT SELECTOR

Metal Panel Ceiling Systems

**CELEBRATION™
SNAP-IN**
(See page 34)

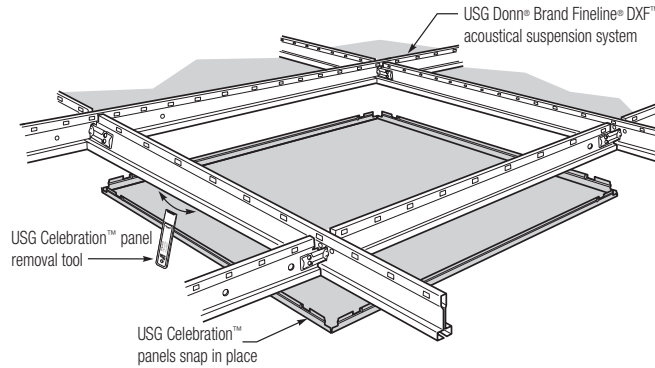

- Aluminum panels provide a monolithic appearance.
- Easy Installation into standard USG Donn® Brand Fineline "DXFEVH" Acoustical Suspension System.
- Available panel sizes: 2' x 2', 2' x 4', 2' x 6', 2' x 8', 4' x 4', 30" X 30" & 30" X 60".
- Downward panel access is excellent for shallow plenum areas.
- Approved for installation in seismic category C, D, E, & F.
- NOA issued by Miami Dade County.

PRODUCT PERFORMANCE RANGES

Pressure psf (kPa)		Wind speed mph (Kph)
Up	Down	
30 to 102 (1.44 to 4.88)	-25 to -70 (-1.20 to -3.35)	98 to 200 (158 to 321)

STANDARD PAINTED METALS



ANODIZED METALS

TIMBRE™



**CELEBRATION™
TORSION SPRING
(WITH HEAVY DUTY ZXLA™)**
(See page 34)

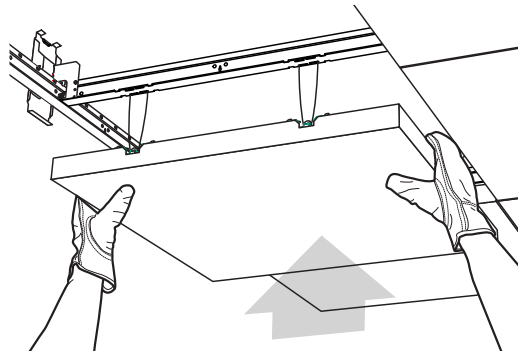

- Aluminum panels provide a monolithic appearance.
- Spring clip design provides superior panel alignment.
- Full 90-degree swing-down motion.
- Downward panel access is excellent for shallow plenum areas.
- Available panel sizes: 2' x 2', 2' x 4', 2' x 6', 2' x 8' & 4' x 4'.
- Approved for installation in seismic category C, D, E, & F.
- NOA issued by Miami Dade County.

PRODUCT PERFORMANCE RANGES

Pressure psf (kPa)		Wind speed mph (Kph)
Up	Down	
15 to 133 (0.72 to 6.37)	-13.3 (-0.64)	72 to 228 (124 to 367)

STANDARD PAINTED METALS



ANODIZED METALS

PRODUCT SELECTOR

Lay-In Panels

**USG SHEETROCK® BRAND
LAY-IN PANELS (GLIP)
(WITH HEAVY DUTY ZXLA™)**
(See page 48)



PRODUCT PERFORMANCE RANGES

Pressure psf (kPa)		Wind speed mph (Kph)
Up	Down	
21 to 85 (1.01 to 4.07)	-68 (-3.25)	90 to 182 (145 to 293)

STANDARD PAINTED METALS



Flat White
050

- Washable and scrubbable finish-impact and scratch resistant.
- Recommended for garage applications.
- Available panel sizes: 2' x 2' & 2' x 4'.
- Approved for installation in seismic category C, D, E, & F.

Continuous Ceilings

**DRYWALL
SUSPENSION SYSTEM**
(See page 54)

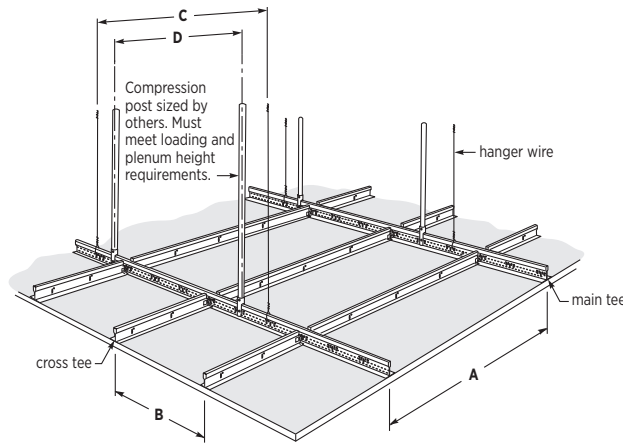

PRODUCT PERFORMANCE RANGES

Pressure psf (kPa)		Wind speed mph (Kph)
Up	Down	
15 to 90 (0.72 to 4.31)		77 to 188 (124 to 302)

FIELD PAINTED



- Must be finished for exterior application. See document WB2451 for additional information.
- Apply a synthetic-type direct-applied finish system in accordance with finish manufacturer's recommendations.
- Approved for installation in seismic category C, D, E, & F.
- NOA issued by Miami Dade County.

LINEAR METAL CEILING SYSTEMS

PARALINE® II, PARALINE® PLUS AND PLANX™ UNIVERSAL

Technical Data

Main Tee	All Acceptable Panel Sizes (Inch)	Main Tee Spacing (Inch)	Cross Tee Spacing (Inch)	Compression Post Spacing (Inch)	Test Standard	Maximum Load Rating (psf)		Equivalent Wind Speed mph (kph)
						Uplift psf (kPa)	Downward psf (kPa)	
Symmetrical Carrier	3-1/4	24	N/A	24	UL 1897 ¹	102 (4.88)	-106 (-5.08)	200 (322)
	3-1/4	24	N/A	24	UL 580 ²	90 (4.31)		188 (302)
	3-1/4	48	N/A	24	UL 1897 ¹	46 (2.20)		135 (217)
Paralock Plus	3, 7, 11	48	24	24	UL 580 ²	30 (1.44)		98 (158)
	3, 7, 11	48	24	24	UL 1897 ¹	55 (2.63)		147 (237)
	3	24	24	24	UL 1897 ¹	127 (6.08)	-38 (-1.82)	222 (357)
	7, 11	24	24	24	UL 1897 ¹	127 (6.08)	-25 (-1.20)	222 (357)
	3, 7, 11	24	24	24	UL 580 ²	90 (4.31)		188 (302)
	3, 7, 11	24	24	30	UL 580 ²	60 (2.87)		153 (246)
	3 and 7	24	24	24	Miami Dade NOA TAS 202 & 203 ⁵	75 (3.59)	-35 (-1.68)	171 (275)
Main Tee Assembly	4", 6", 8", 10" and 12"	48	24	24	UL 1897 ¹		-77 (-3.68)	173 (279)
		24	24	24	UL 1897 ¹	103 (4.91)		200 (322)
	4", 6", 8" and 10"	48	24	24	UL 1897 ¹		-73 (-3.48)	168 (271)
	4", 6", 8" and 10"	24	24	24	UL 1897 ¹		-51 (-2.46)	142 (228)

1. Factor of safety of 1.17 is included.

2. Factor of safety of 1.5 for 30 psf; 1.3 for 60 psf; 1.17 for 90 psf is included per test standard.

3. Factor of safety of 1.5 is included per test standard.

4. ICC-ES ESL-1652 issued for exterior applications.

PARALINE® II

PARALINE® PLUS

PLANX™ UNIVERSAL⁴
OPTIONAL REVEAL (OR)

INTEGRAL REVEAL (IR)

NO REVEAL (NR)

LINEAR METAL CEILING SYSTEMS

PARALINE® II, PARALINE® PLUS AND PLANX™ UNIVERSAL

WIND RESISTANCE

USG Paraline® ceiling systems and USG Planx™ Universal may be used for protected exterior applications not directly exposed to the weather. The Paraline® II, Paraline® Plus and Planx™ Universal systems have been tested for wind load resistance. The two units of measure commonly used are miles per hour (mph) and pounds per square foot (psf), equated by the methods in ASCE 7, Minimum Design Loads for Buildings and Other Structures, American Society of Civil Engineers/Structural Engineering Institute (ASCE/SEI).¹

Limitations: The Paraline® and Planx™ Universal finish is not UV-resistant; therefore, these ceiling systems should not be installed where direct exposure to sun or weather will occur, such as fascias or facades. These ceiling systems are not suitable for areas subject to high concentrations of acid rain. Indirect exposure to severe environmental conditions may shorten the lifespan of these products. The specific design of exterior ceiling installations requires the review and approval of the architect or engineer of record. For more information refer to *Paraline® Linear Metal Ceiling Systems IC463*, Planx™ Universal Install Guide IC349054 and ICC-ES ESL-1652.

TECHNICAL DATA

- The wind pressure is presented in accordance with applicable test standards.
- The compression posts used for the tests were minimum 1-5/8", 20-gauge steel studs. (maximum length of 24")
- For Paraline® II tests, EMT conduit with USG top and bottom clips were used.

GUIDELINES

- The building structure from which the Paraline® and Planx™ Universal systems are suspended, as well as hanger wire and compression post attachment connections must be capable of withstanding the design loads connections. For further information on the compression post, see page 59.
- Other materials can be used for compression posts, provided the capacity and attachment connections are approved for use by a structural engineer of record.
- The architect's details must cover the design and location of expansion joints and meet all applicable building code requirements.

PANEL SIZES

The Paraline® II and Paraline® Plus systems presented in this guide can accommodate 3-1/4" wide pans for Paraline® II and 3", 7" & 11" wide Paraline® Plus pan sizes.

The Planx™ Universal No Reveal & Integral Reveal can accommodate 4", 6", 8" & 10" wide panels. The Planx Universal Optional Reveal can accommodate 4", 6", 8", 10" & 12" wide panels.

1. The system shall comply with local wind load requirements. The engineer of record shall determine the final recommendation for the design wind pressure requirements of each project.

For more information about Paraline® linear metal ceiling systems, visit usg.com

LINEAR METAL CEILING SYSTEMS

PARALINE® II

System Components

PERIMETER MOLDING

U-2-3/32

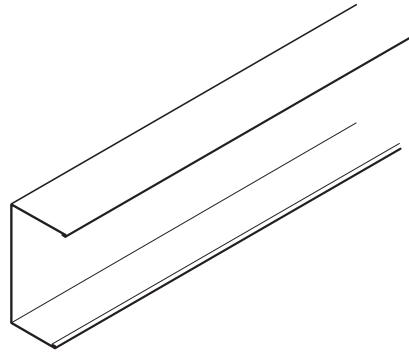
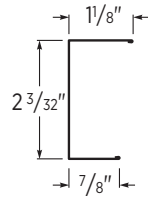

ACCESSORIES

U-2-3/32 Hold-Down Clip

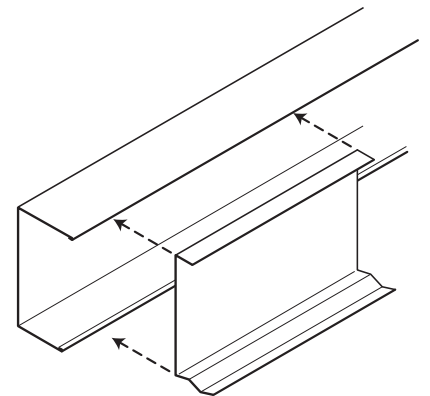
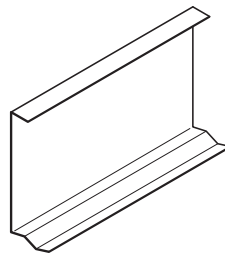
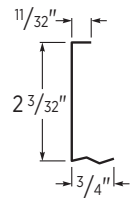

LINEAR METAL CEILING SYSTEMS

PARALINE® II

Application Details

GENERAL LAYOUT¹

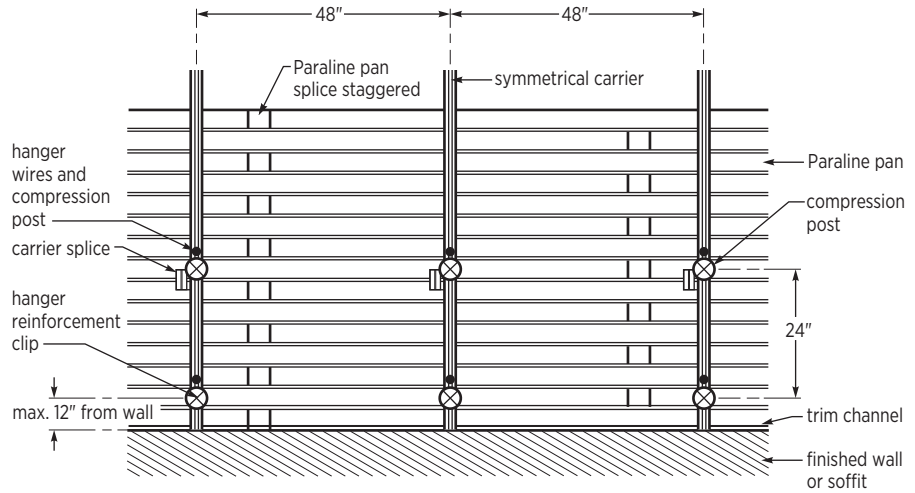

¹ The product layout and spacing will vary based on the load rating and uplift class. Refer to the technical data and associated reference pages for details.

USG SYMMETRICAL CARRIER RUN

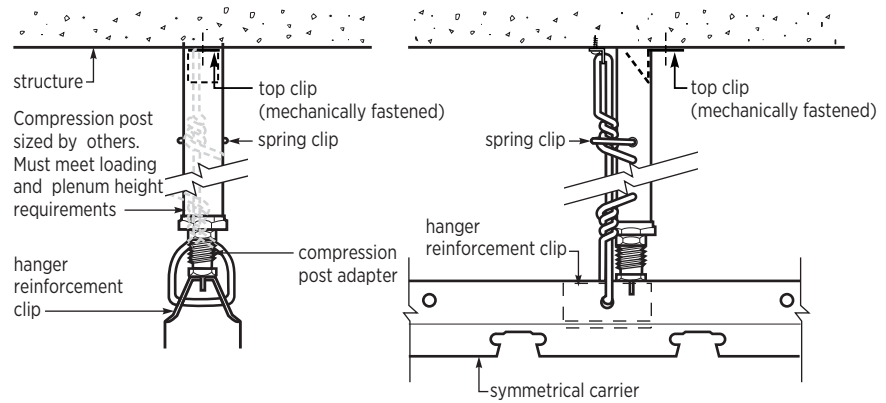

COMPRESSION POST DETAIL

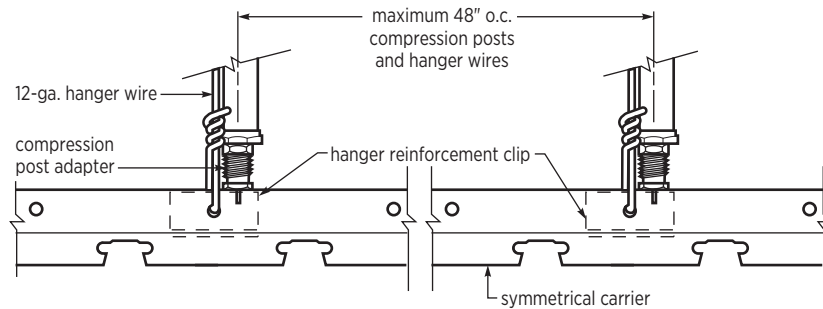

LINEAR METAL CEILING SYSTEMS

PARALINE® II

Application Details

WALL INTERSECTION

Pans Perpendicular to Wall

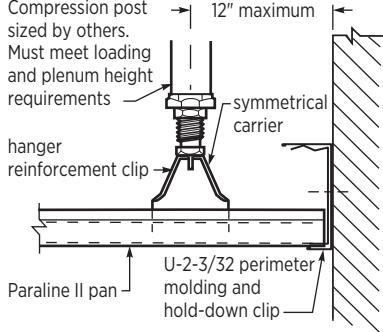

Pans Parallel to Wall

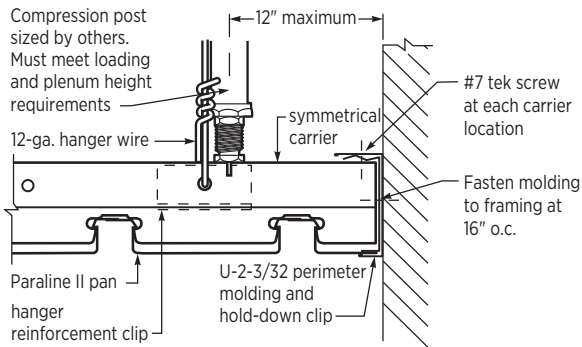

LINEAR METAL CEILING SYSTEMS

PARALINE® II

UL 1897
46 psf

Main Tees: 48 in. o.c.
Compression Posts: 24 in. o.c.

- ⊗ Hanger & Compression Post
- Paraline® Symmetrical Carrier

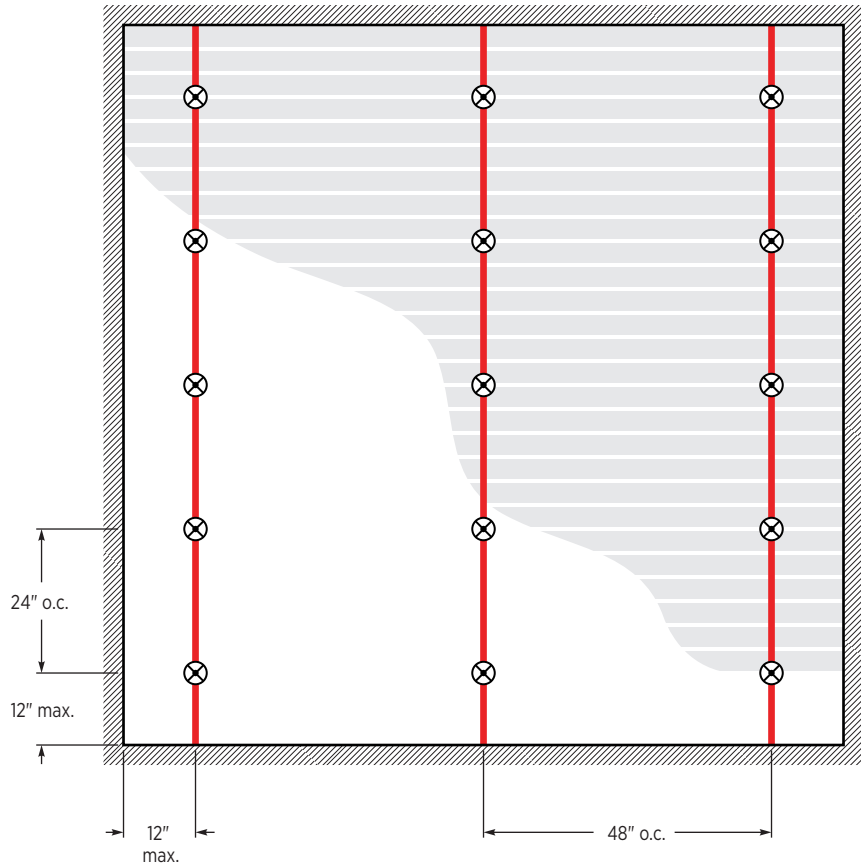

Paraline® II Assembly

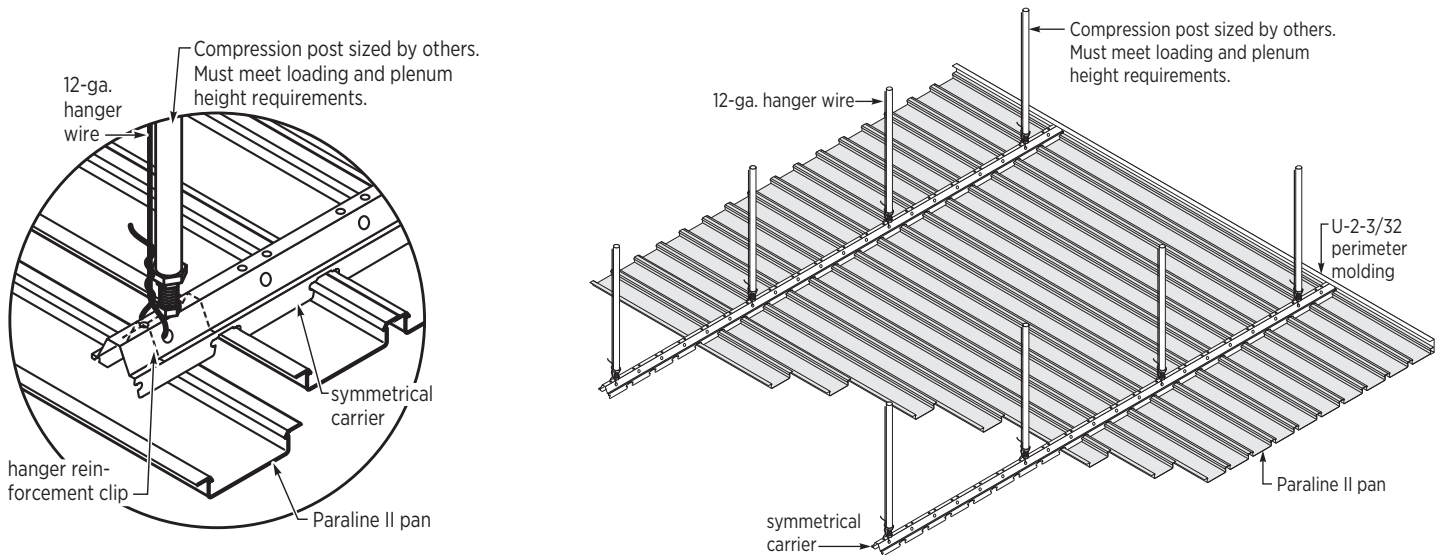

LINEAR METAL CEILING SYSTEMS

PARALINE® II

UL 580
Class 90

Main Tees: 24 in. o.c.
Compression Posts: 24 in. o.c.

- ⊗ Hanger & Compression Post
- Paraline® Symmetrical Carrier

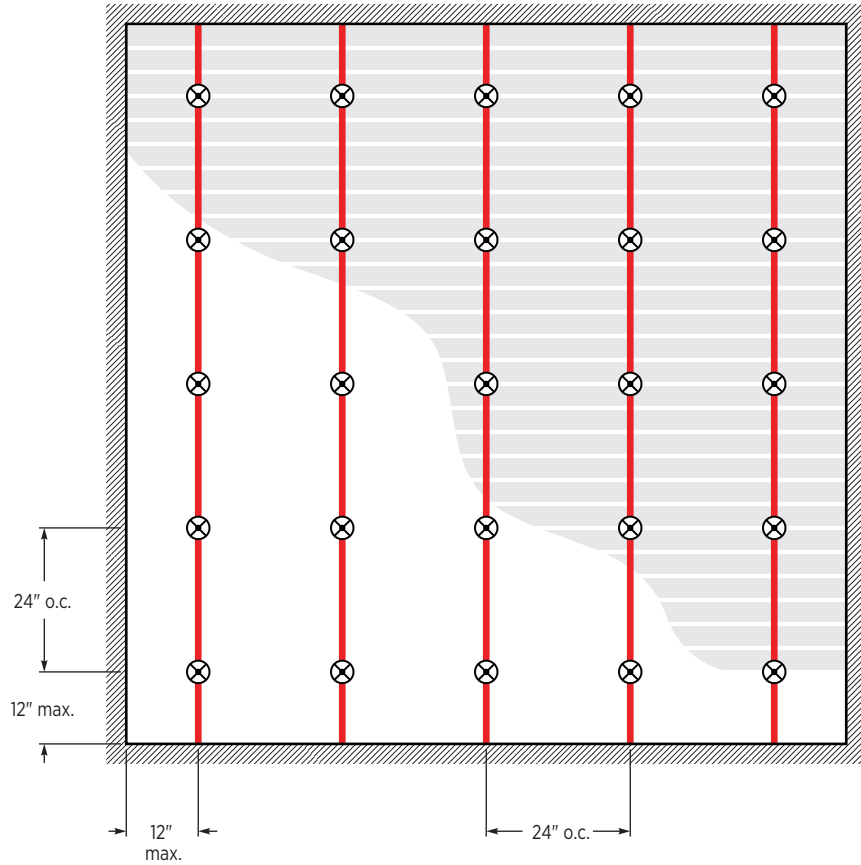

Paraline® II Assembly

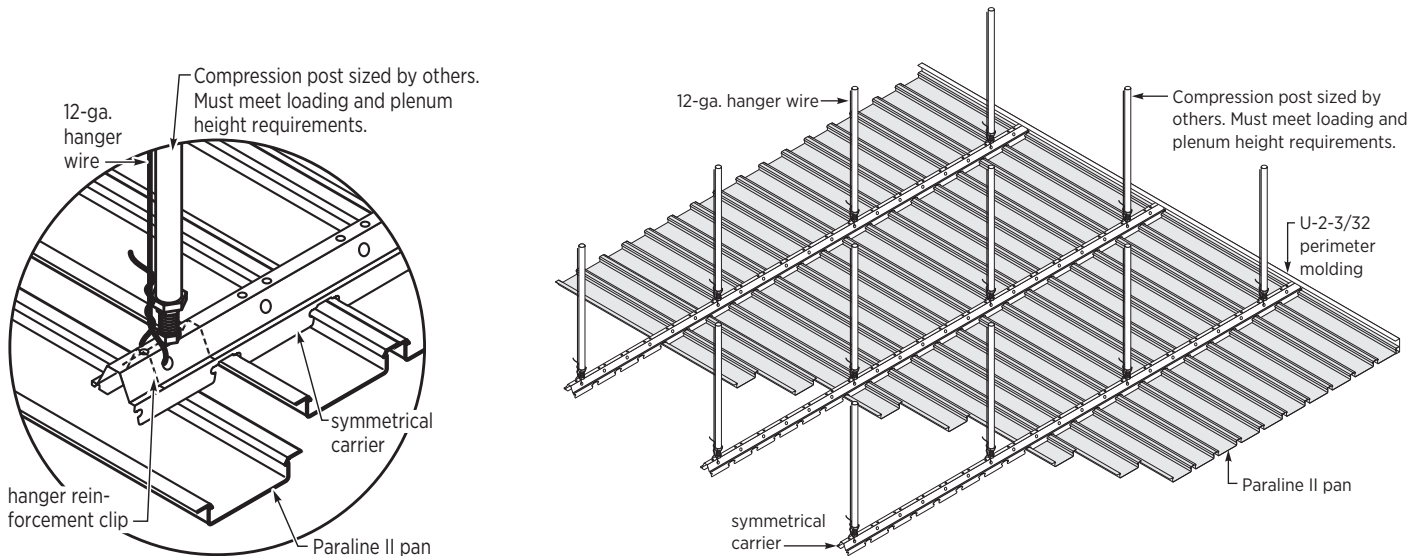

LINEAR METAL CEILING SYSTEMS

PARALINE® II

UL 1897
106 psf (Downward)

Main Tees: 24 in. o.c.
Compression Posts: 24 in. o.c.

- ⊗ Hanger & Compression Post
- Paraline® Symmetrical Carrier

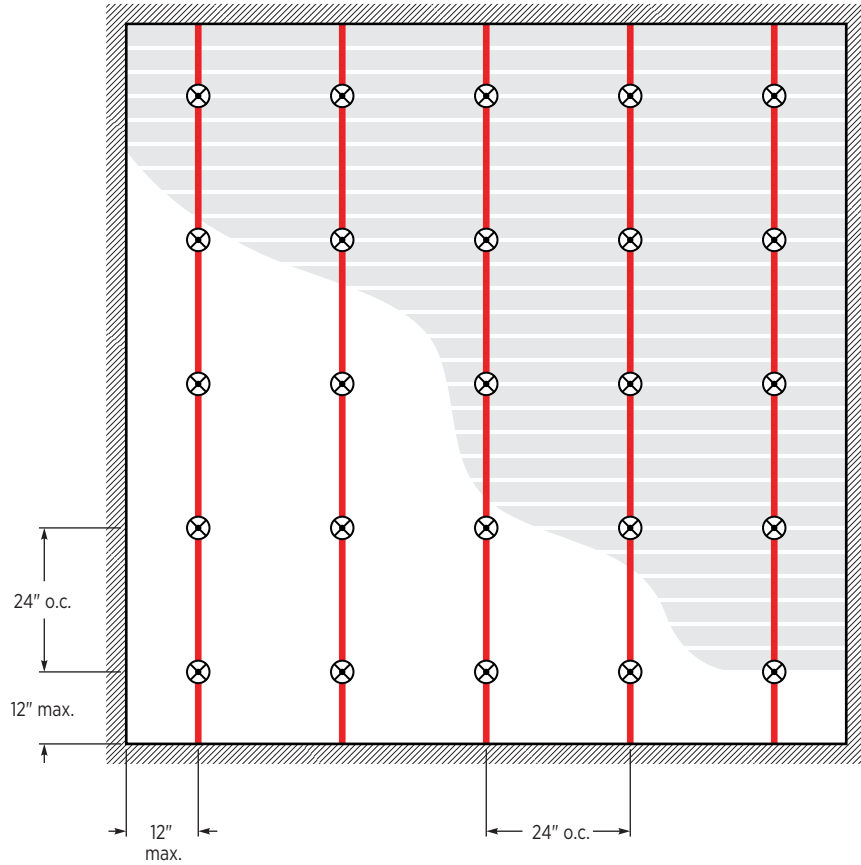

Paraline® II Assembly

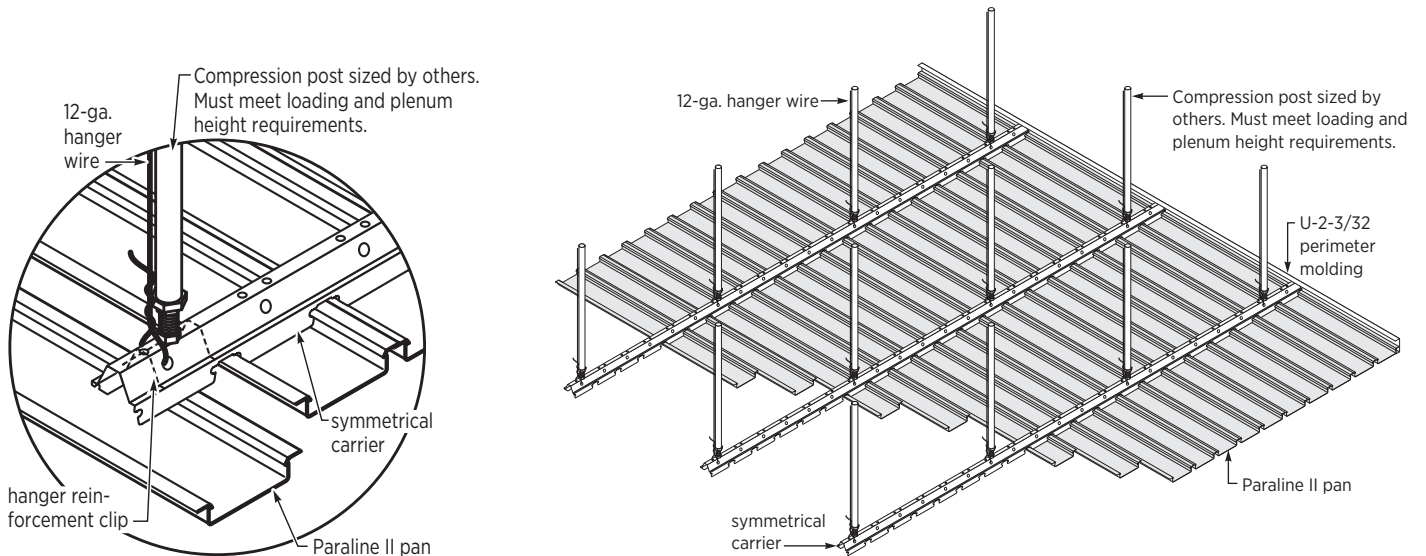

LINEAR METAL CEILING SYSTEMS

PARALINE® PLUS

System Components

PERIMETER MOLDING

U-2-5/8

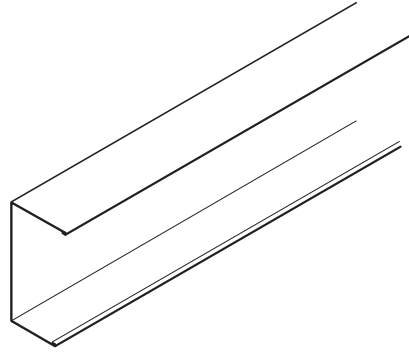
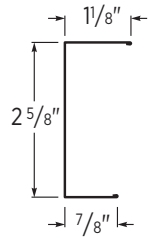

ACCESSORIES

U-2-5/8 Hold-Down Clip

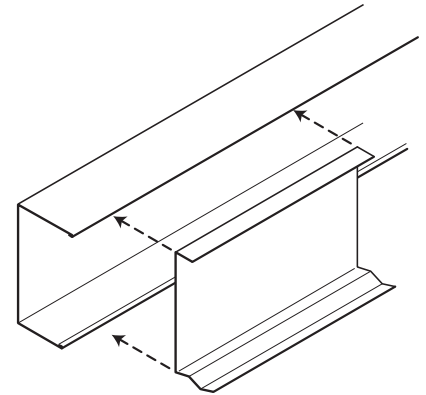
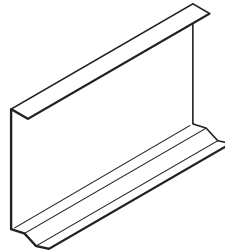
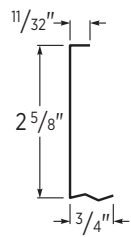

LINEAR METAL CEILING SYSTEMS

PARALINE® PLUS

Application Details

GENERAL LAYOUT¹

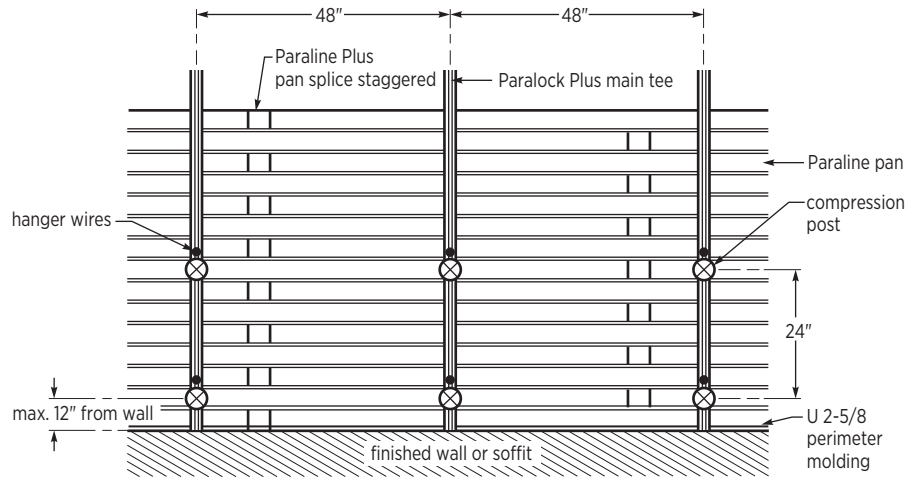

¹ The product layout and spacing will vary based on the load rating and uplift class. Refer to the technical data and associated reference pages for details.

PARALOCK™ CARRIER RUN

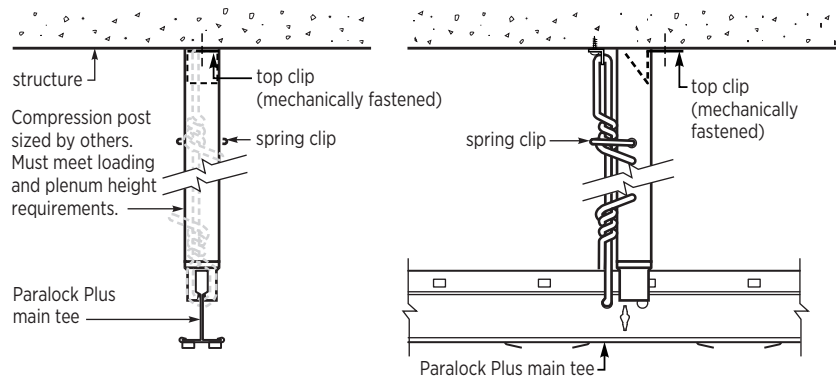

POST DETAIL

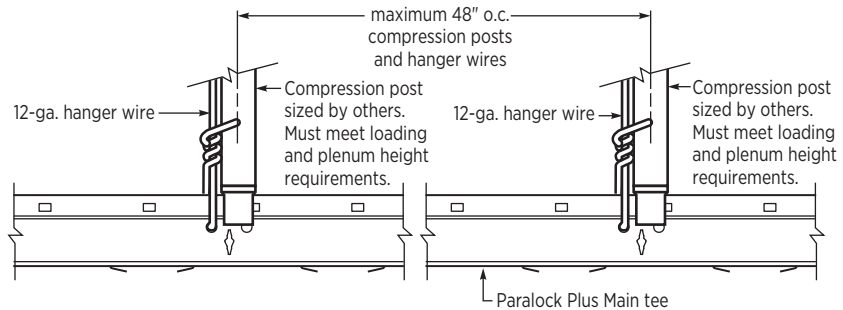

LINEAR METAL CEILING SYSTEMS

PARALINE® PLUS

Application Details

WALL INTERSECTION

Pans Perpendicular to Wall

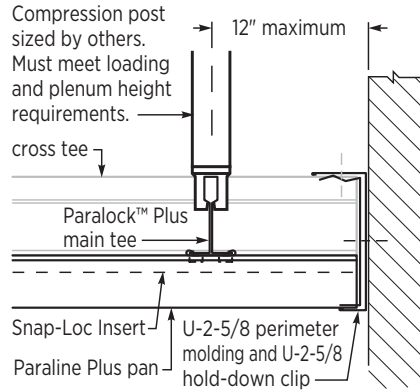

Pans Parallel to Wall

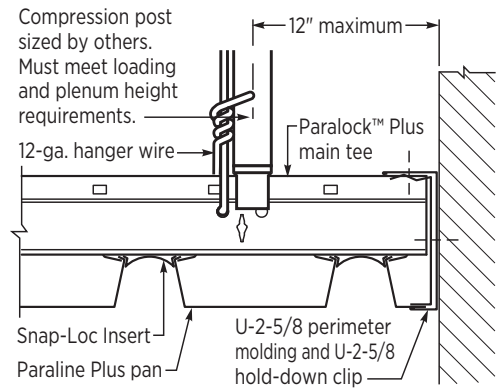

LINEAR METAL CEILING SYSTEMS

PARALINE® PLUS

UL 580
Class 30

UL 1897
55 psf

Main Tees: 48 in. o.c.
Compression Posts: 24 in. o.c.
Cross Tees: 24 in. o.c.

- ⊗ Hanger & Compression Post
- Paralock™ Plus Main Tee
- ZXLA™424 (48 in. Cross Tee)

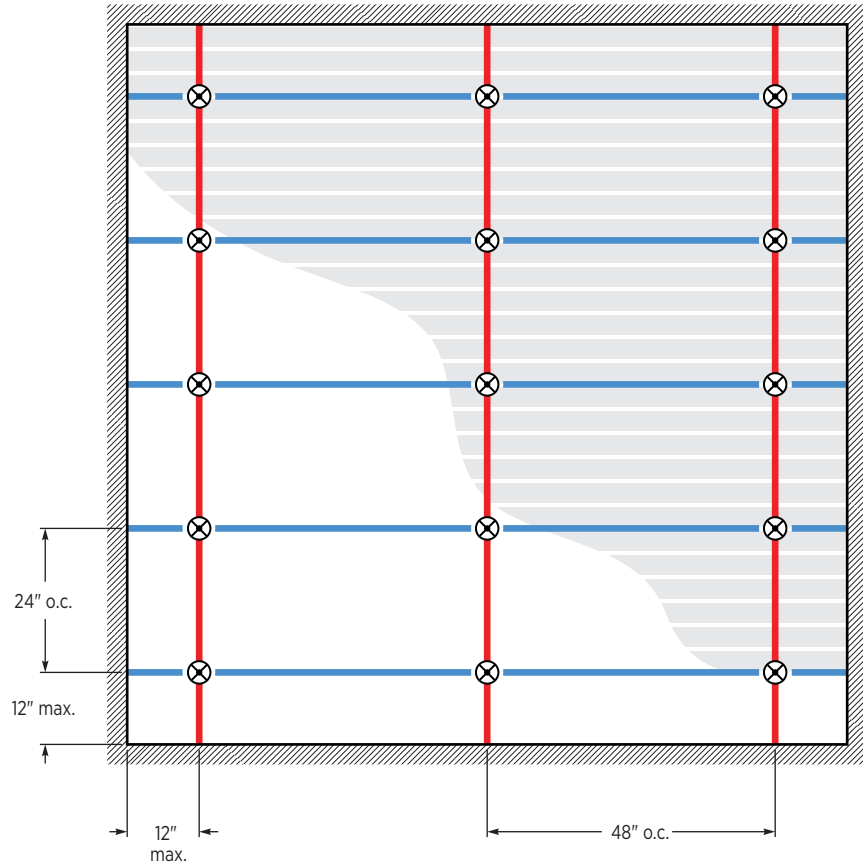

Paraline® Plus Assembly

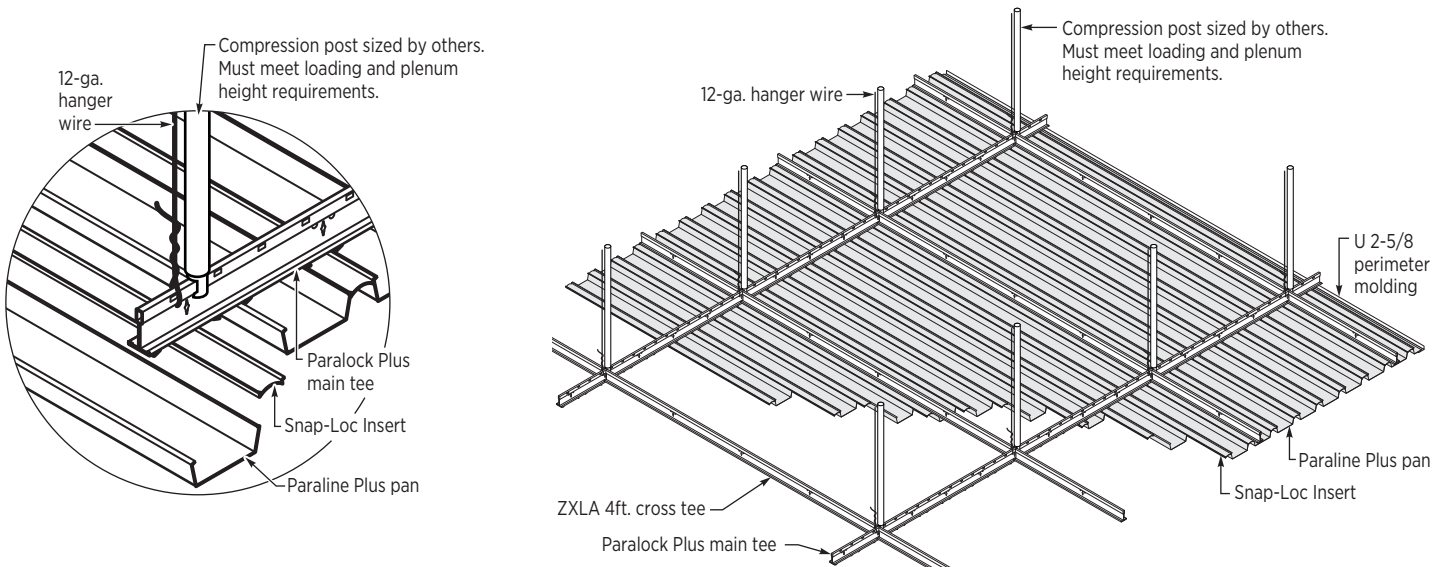

LINEAR METAL CEILING SYSTEMS

PARALINE® PLUS

UL 580
Class 60

Main Tees: 24 in. o.c.
Compression Posts: 30 in. o.c.
Cross Tees: 24 in. o.c.

- ⊗ Hanger & Compression Post
- Paralock™ Plus Main Tee
- ZXLA™224 (24 in. Cross Tee)

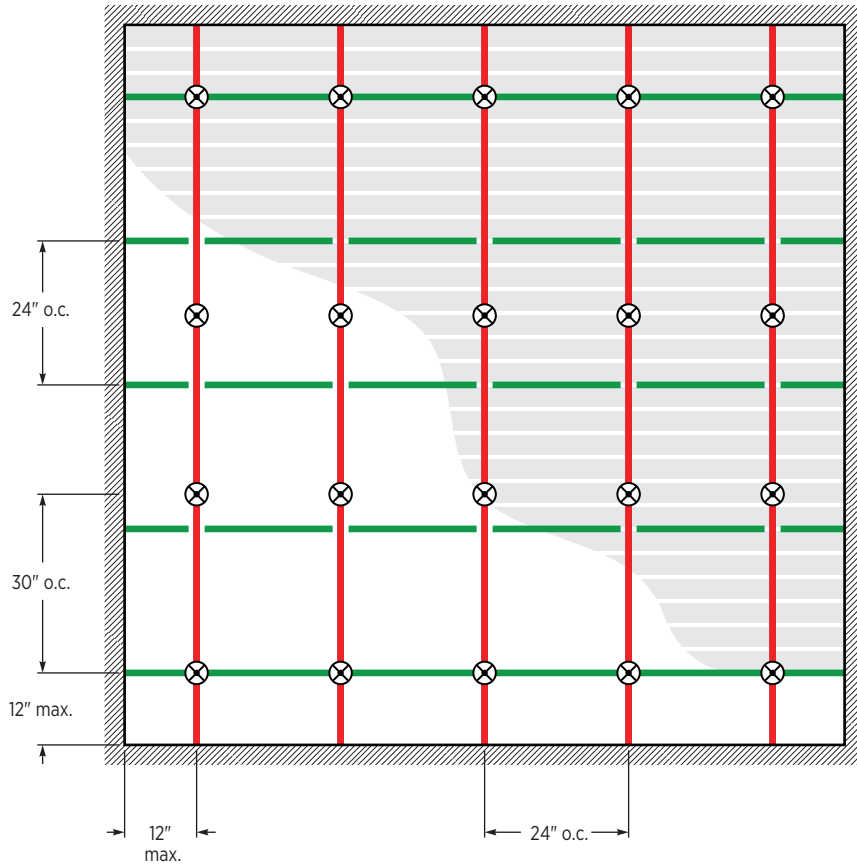

Paraline® Plus Assembly

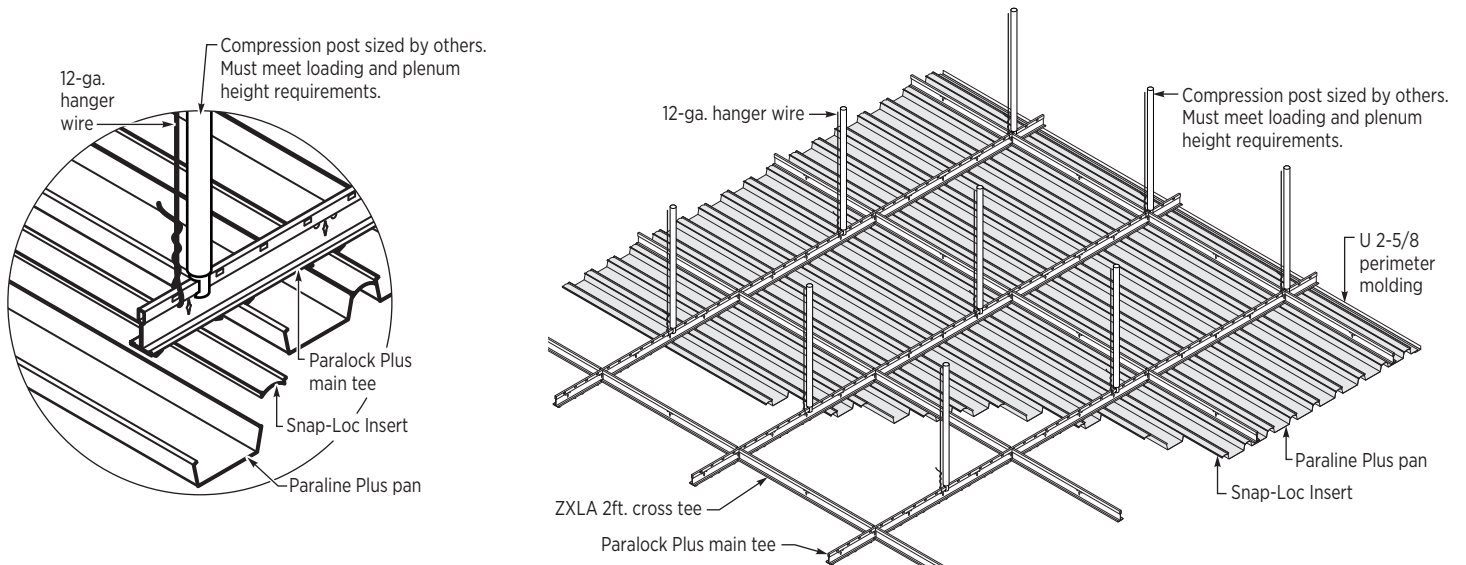

LINEAR METAL CEILING SYSTEMS

PARALINE® PLUS

UL 580
90 psf

UL 1897
102 psf

Miami-Dade NOA No. 24-1011.09
171 mph

Main Tees: 24 in. o.c.
Compression Posts: 24 in. o.c.
Cross Tees: 24 in. o.c.

- ⊗ Hanger & Compression Post
- Paralock™ Plus Main Tee
- ZXLA™224 (24 in. Cross Tee)

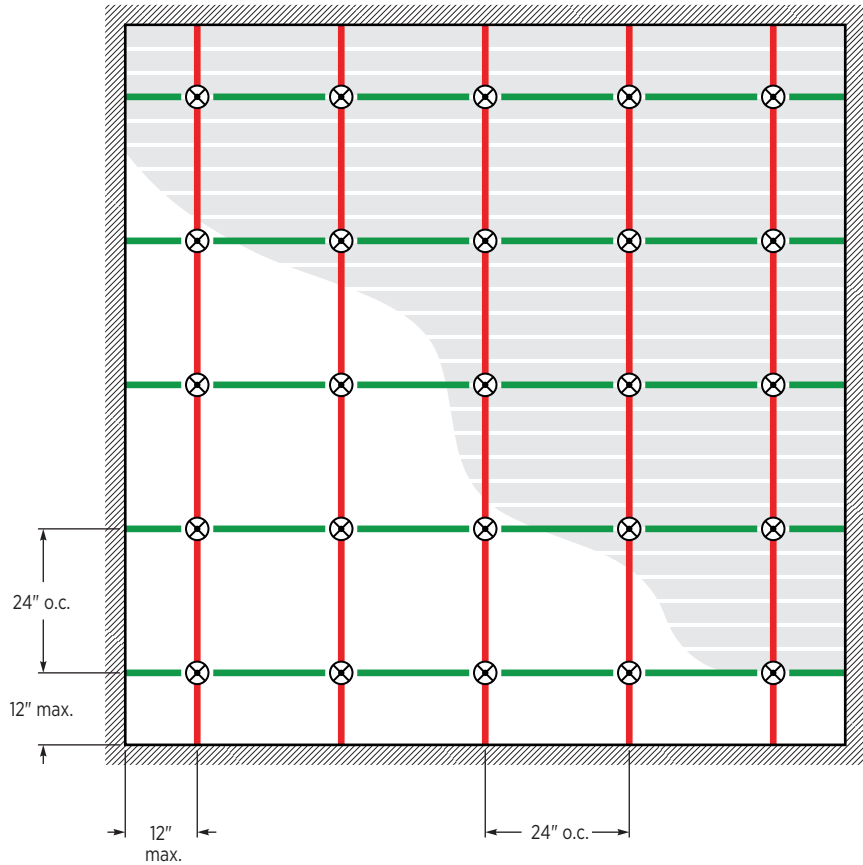

Paraline® Plus Assembly

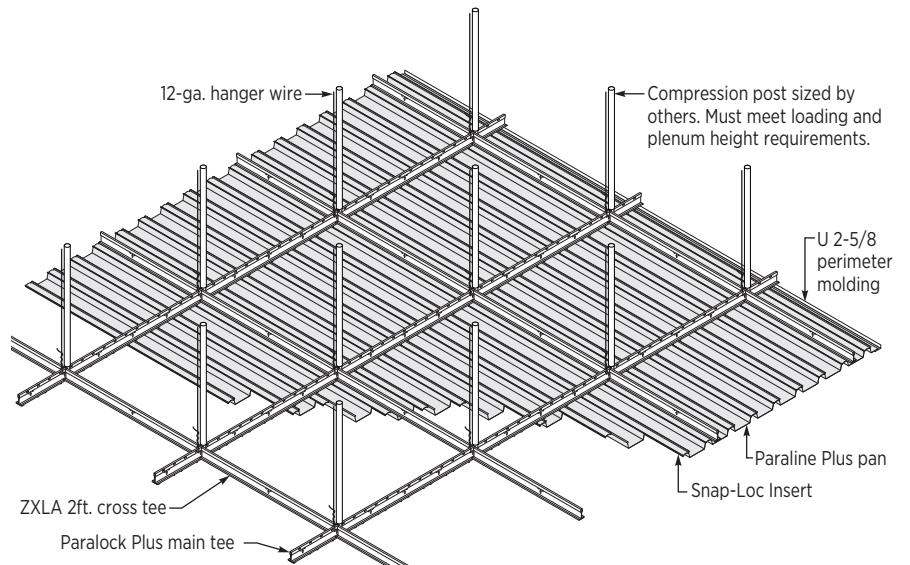
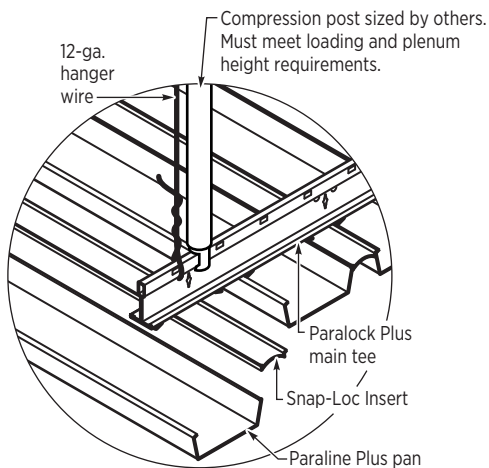

LINEAR METAL CEILING SYSTEMS

PARALINE® PLUS

UL 1897

17 psf (Downward Load)

Main Tees: 24 in. o.c.
Compression Posts: 24 in. o.c.
Cross Tees: 24 in. o.c.

- ⊗ Hanger & Compression Post
- Paralock™ Plus Main Tee
- ZXLA™224 (24 in. Cross Tee)

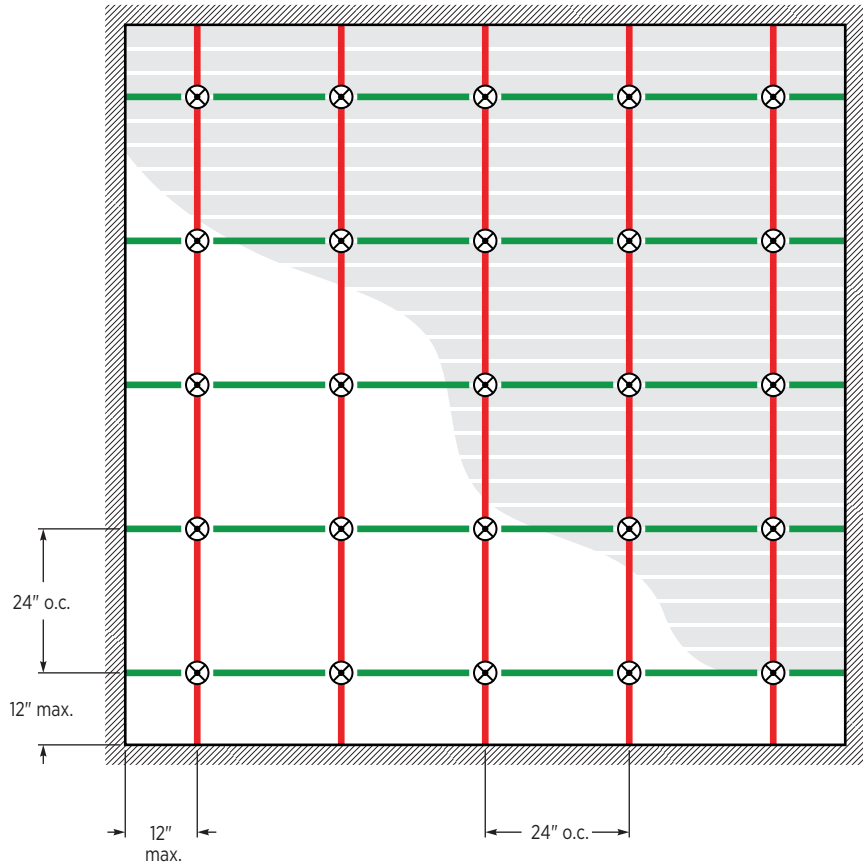

Paraline® Plus Assembly

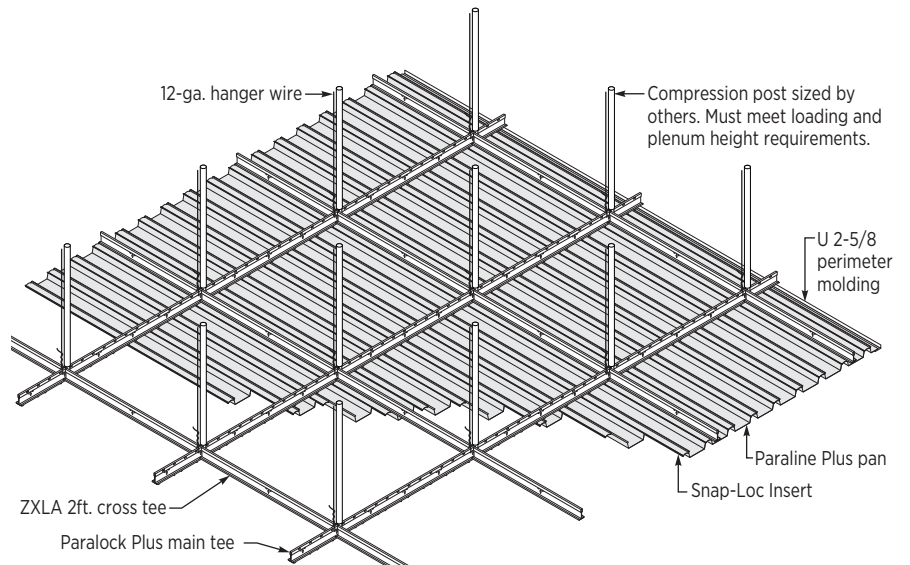
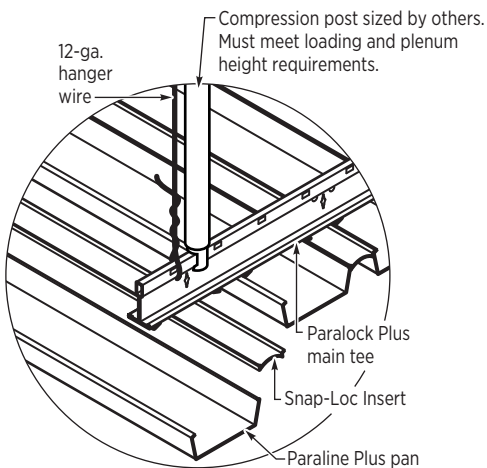

LINEAR METAL CEILING SYSTEMS

PLANX™ UNIVERSAL

System Components

PERIMETER MOLDING (12' long)

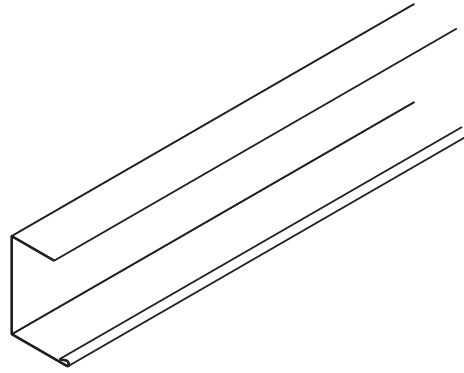
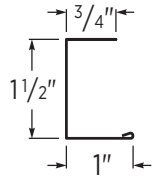

ACCESSORIES

Hold-Down Clip (2-3/4" long)

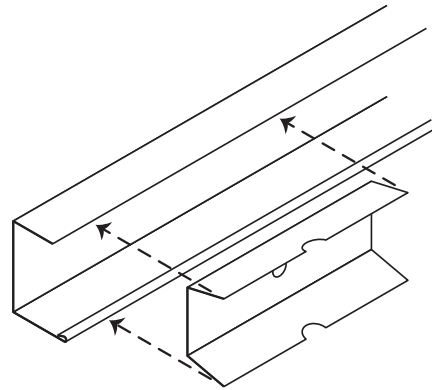
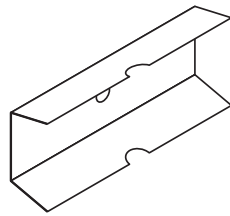
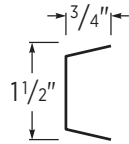

Planx Universal No Reveal (NR) Panel Retention Clip (@ 4'-0" o.c. placed within 2" max. from carrier main tees)

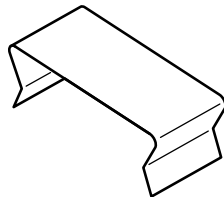

LINEAR METAL CEILING SYSTEMS

PLANX™ UNIVERSAL

Application Details

GENERAL LAYOUT¹

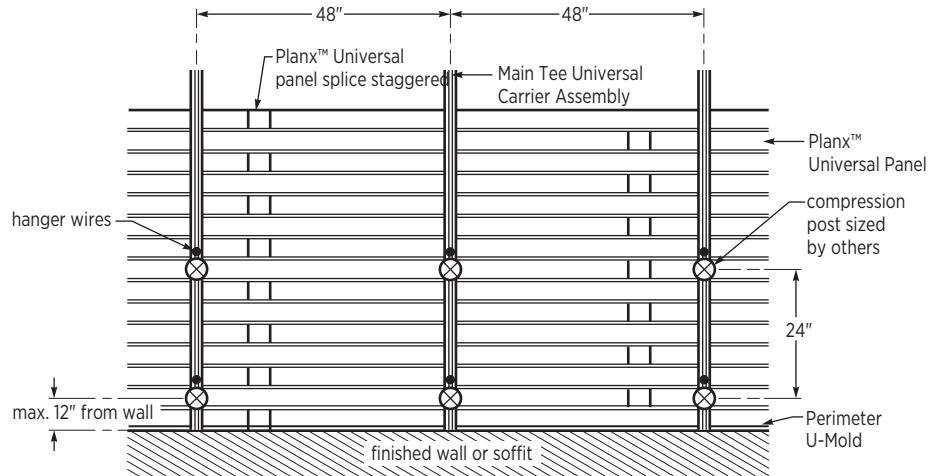

1. The product layout and spacing will vary based on the load rating and uplift class. Refer to the technical data and associated reference pages for details.

MAIN TEE UNIVERSAL CARRIER ASSEMBLY RUN

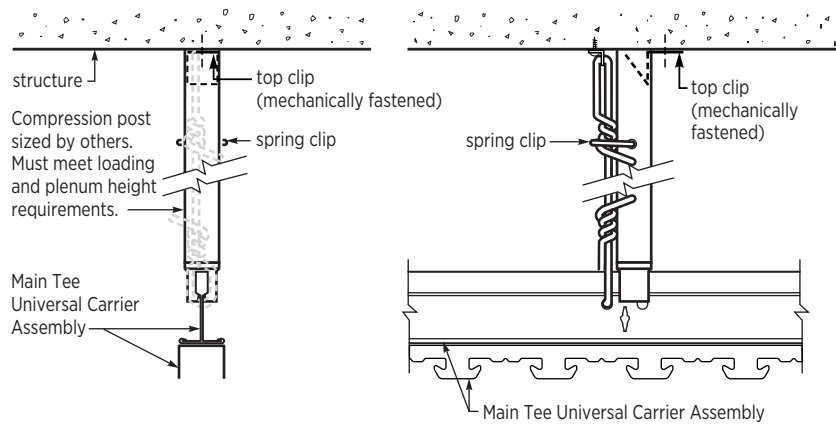

POST DETAIL

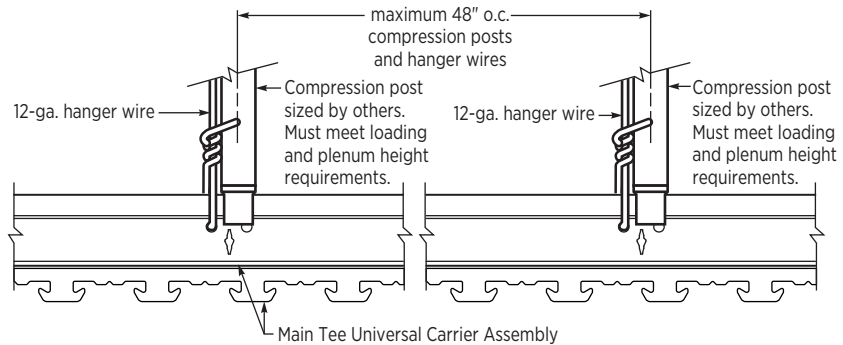

LINEAR METAL CEILING SYSTEMS

PLANX™ UNIVERSAL

Application Details

WALL INTERSECTION

Optional Reveal (Shown)

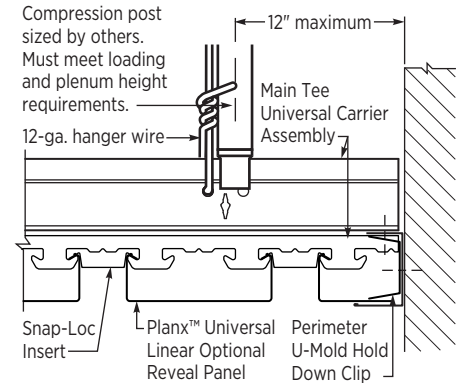
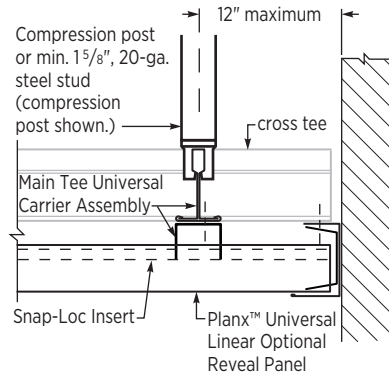

OTHER DETAILS

Optional Reveal

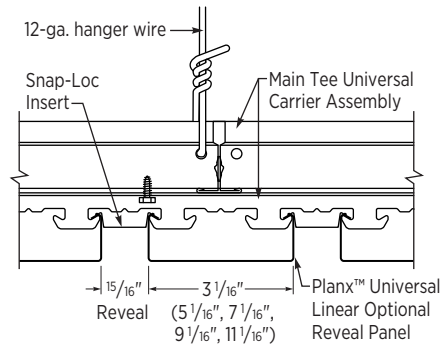

Integral Reveal

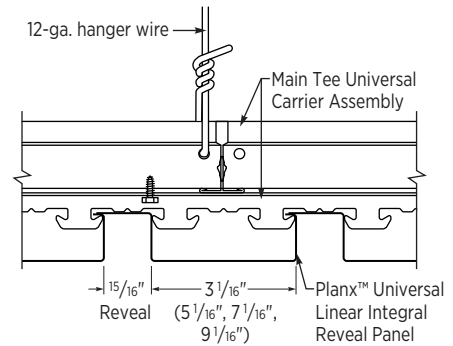

No Reveal

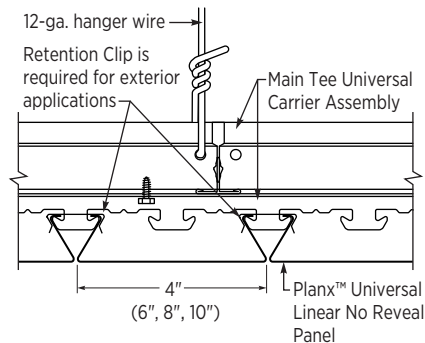

LINEAR METAL CEILING SYSTEMS

PLANX™ UNIVERSAL - OPTIONAL REVEAL

UL 1897 (ICC-ES ESL-1652)
-77 psf (Downward Load)

Main Tees: 48 in. o.c.
Compression Posts: 24 in. o.c.
Cross Tees: 24 in. o.c.

- ⊗ Hanger & Compression Post
- Exterior Main Tee Universal Carrier Assembly. (Field modified 9 in. o/c max. screws)
- ZXLA™424 (48 in. Cross Tee)

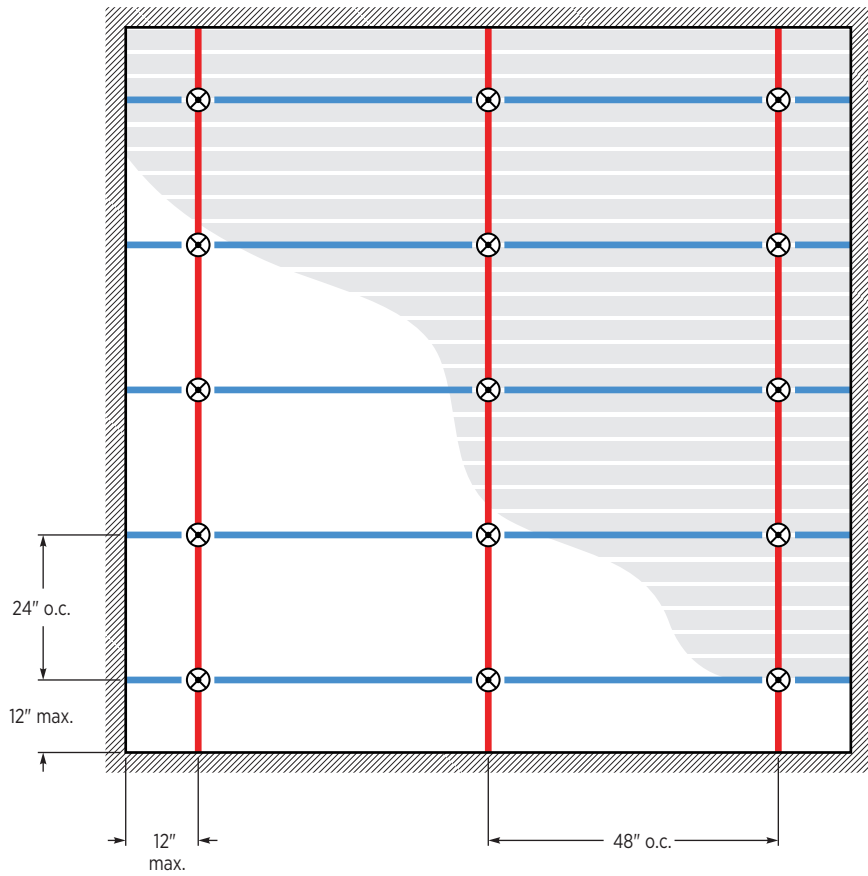

Planx™ Universal - Optional Reveal Assembly

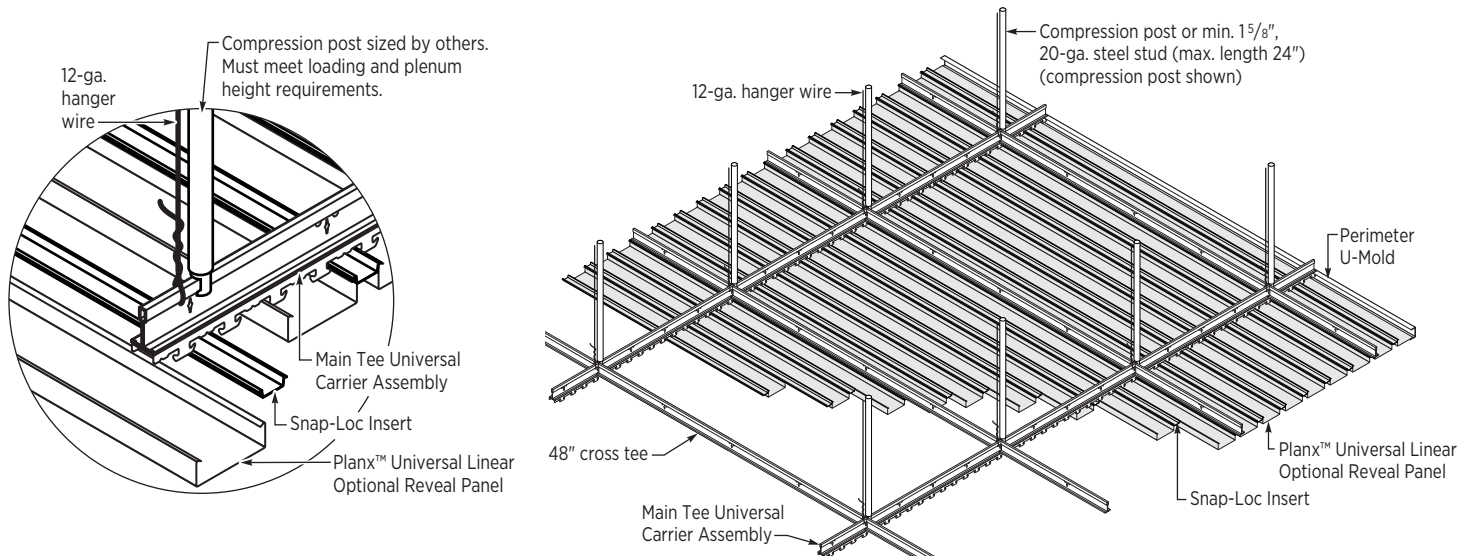

LINEAR METAL CEILING SYSTEMS

PLANX™ UNIVERSAL - OPTIONAL REVEAL

UL 1897 (ICC-ES ESL-1652)
103 psf

Main Tees: 24 in. o.c.
Compression Posts: 24 in. o.c.
Cross Tees: 24 in. o.c.

- ⊗ Hanger & Compression Post
- Exterior Main Tee Universal Carrier Assembly. (Field modified 9 in. o/c max. screws)
- ZXLA™224 (24 in. Cross Tee)

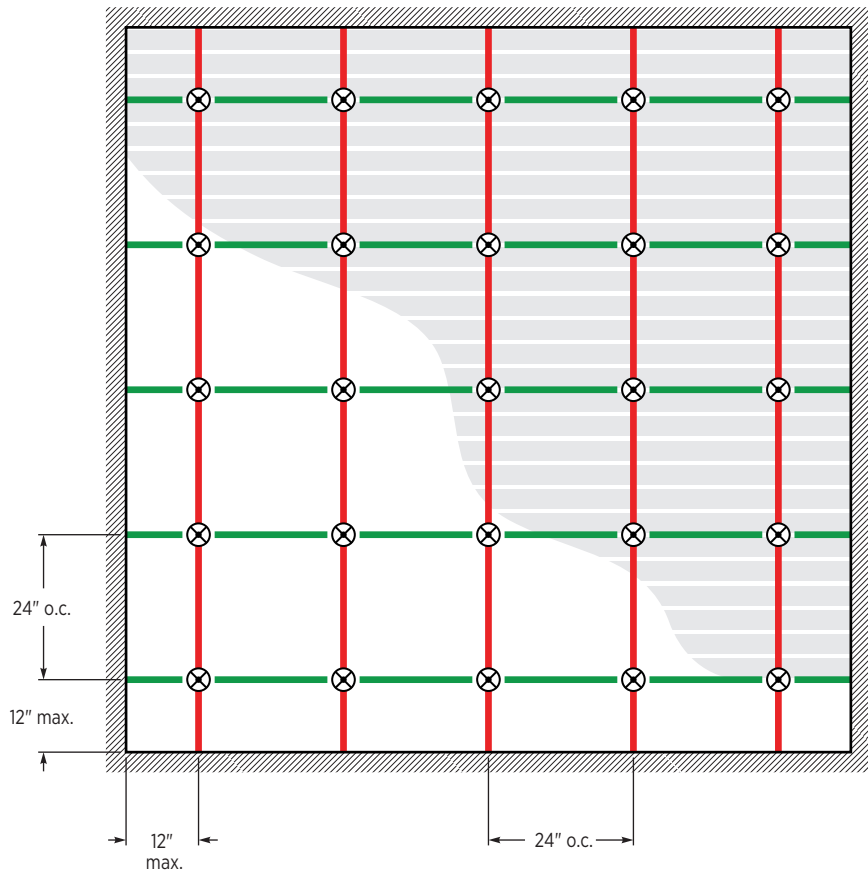

Planx™ Universal - Optional Reveal Assembly

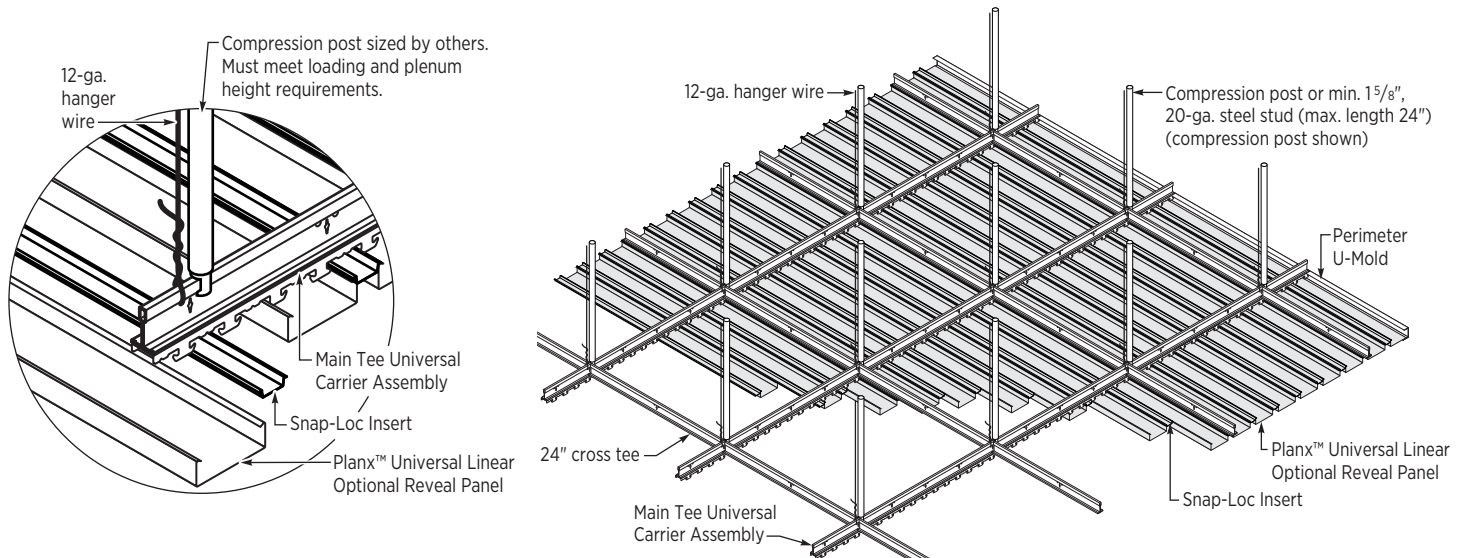

LINEAR METAL CEILING SYSTEMS

PLANX™ UNIVERSAL - INTEGRAL REVEAL

UL 1897 (ICC-ES ESL-1652)
-73 psf (Downward Load)

Main Tees: 48 in. o.c.
Compression Posts: 24 in. o.c.
Cross Tees: 24 in. o.c.

- ⊗ Hanger & Compression Post
- Exterior Main Tee Universal Carrier Assembly. (Field modified 9 in. o/c max. screws)
- ZXLA™424 (48 in. Cross Tee)

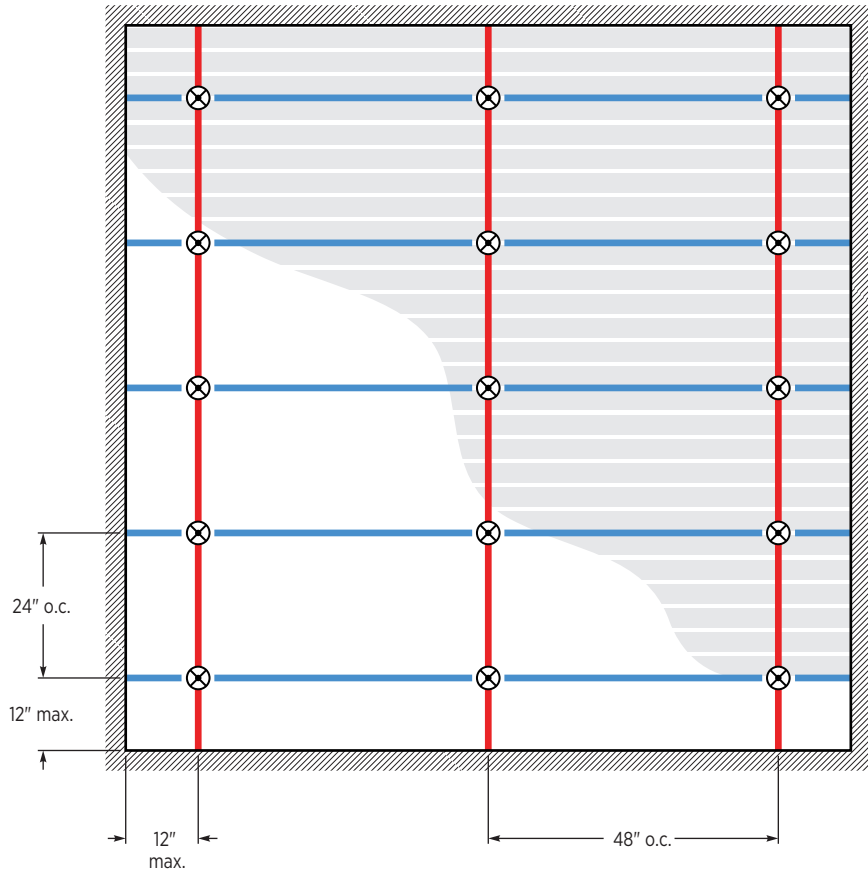

Planx™ Universal - Integral Reveal Assembly

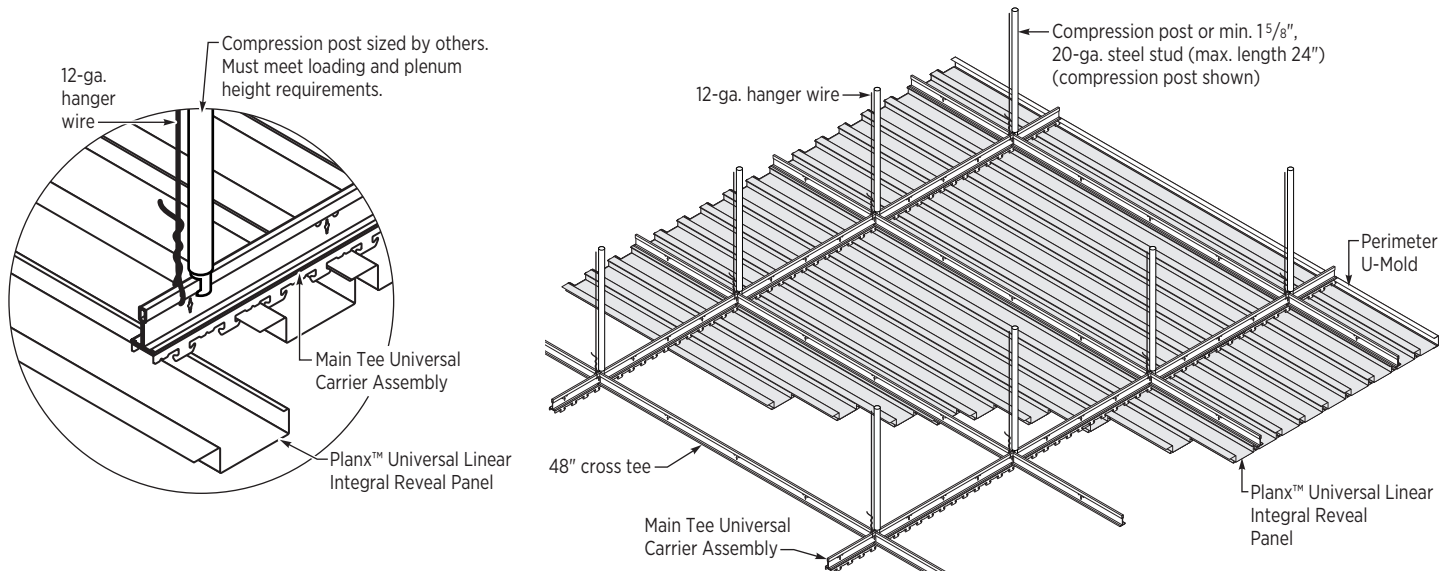

LINEAR METAL CEILING SYSTEMS

PLANX™ UNIVERSAL - NO REVEAL

UL 1897 (ICC-ES ESL-1652) -51 psf (Downward Load)

Main Tees: 24 in. o.c.
Compression Posts: 24 in. o.c.
Cross Tees: 24 in. o.c.

- ⊗ Hanger & Compression Post
- Exterior Main Tee Universal Carrier Assembly. (Field modified 9 in. o/c max. screws)
- ZXLA™224 (24 in. Cross Tee)

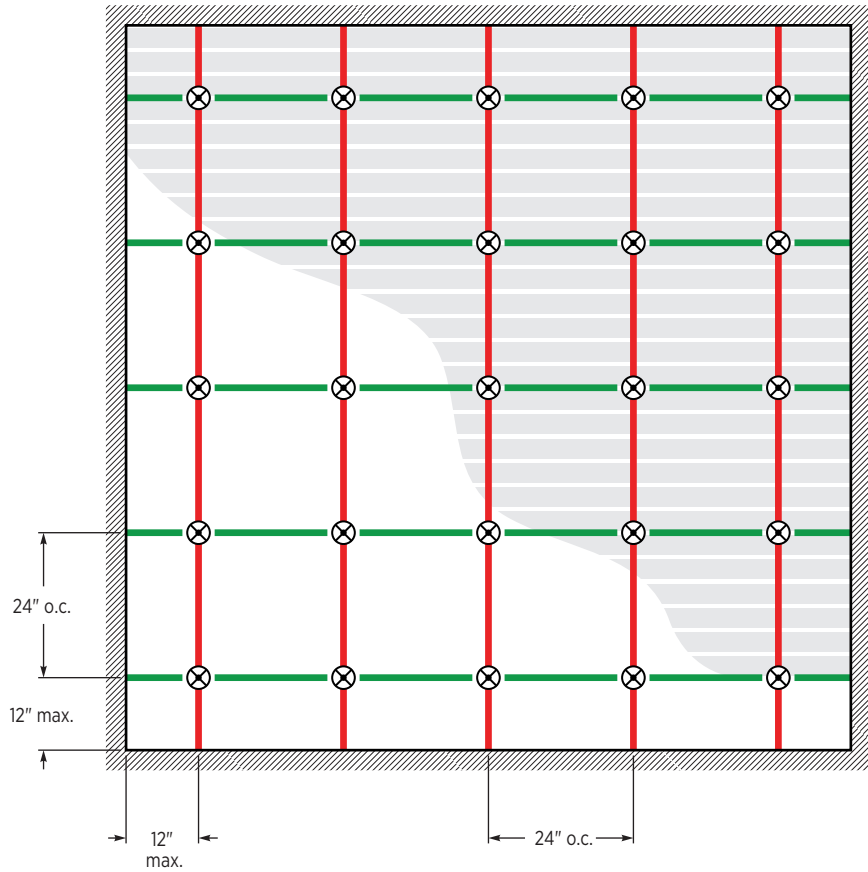

Planx™ Universal - No Reveal Assembly

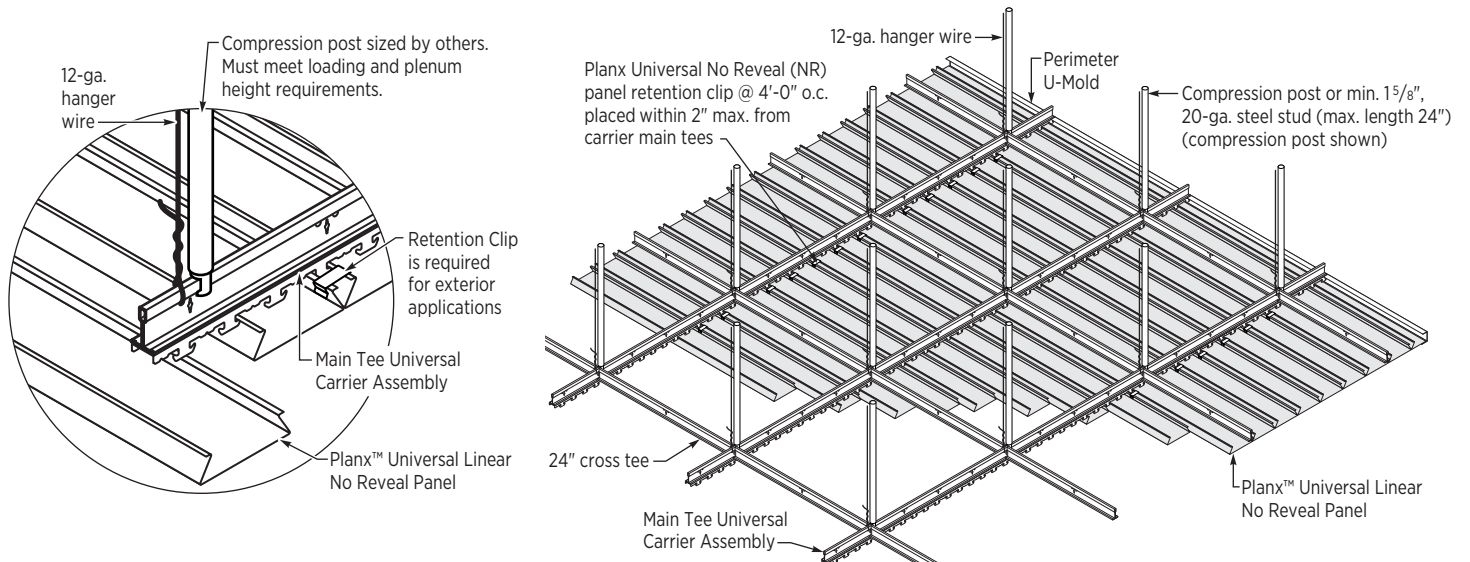

PAGE 24 INTENTIONALLY LEFT BLANK.

METAL PANEL CEILING SYSTEMS

CELEBRATION™ SNAP-IN

CELEBRATION™ TORSION SPRING

CELEBRATION™
SNAP-IN

CELEBRATION™
TORSION SPRING

Technical Data

Main Tee	All Acceptable Panel Sizes (Inch)	Main Tee Spacing (Inch)	Cross Tee Spacing (Inch)	Compression Post Spacing (Inch)	Test Standard	Maximum Load Rating (psf)		Equivalent Wind Speed mph (kph)
						Uplift psf (kPa)	Downward psf (kPa)	
DXFEVH2924	12 x 24, 12 x 48 24 x 24, 24 x 48	48	24	24	UL 1897 ¹	30 (1.44)	-25 (-1.20)	98 (158) ⁴
	24 x 24, 24 x 48 24 x 72, 24 x 96	24	24	24	UL 580 ²	90 (4.31)		188 (302)
	24 x 24, 24 x 48 24 x 72, 24 x 96	24	24	24	UL 1897 ¹	102 (4.88)		200 (321)
	24 x 24, 24 x 48	24	24	24	Miami Dade NOA TAS 202 & 203 ³	80 (3.83)	-70 (-3.35)	165 (266) ⁴
DXFEVH2930	30 x 30, 30 x 60	30	30	30	UL 1897 ¹	72 (3.45)	-51 (-2.44)	141 (227) ⁴
	30 x 30, 30 x 60	30	30	30	UL 580 ²	60 (2.87)		153 (246)
ZXLA™26	24 x 24, 24 x 48	24	24	24	UL 580 ²	90 (4.31)		188 (302)
	24 x 24, 24 x 48	24	24	24	UL 1897 ¹	133 (6.37)		228 (367)
	24 x 24	24	24	24	Miami Dade NOA TAS 202 & 203 ³	73.3 (3.51)	-13.3 (-0.64)	170 (274)
	24 x 72	72	24	48/24	UL 580 ²	30 (1.44)		98 (158)
	48 x 48	48	24	48	UL 580 ²	15 (0.72)		77 (124)
	24 x 48, 24 x 96	48	24	24	UL 580 ²	30 (1.44)		98 (158)

1. Factor of safety of 1.17 is included.

2. Factor of safety of 1.5 for 30 psf; 1.3 for 60 psf; 1.17 for 90 psf is included per test standard.

3. Factor of safety of 1.5 is included per test standard.

4. Corresponds to the lowest value. Consult to technical representatives for project specific needs.

METAL PANEL CEILING SYSTEMS

CELEBRATION™ SNAP-IN

CELEBRATION™ TORSION SPRING

WIND RESISTANCE

Both USG Celebration™ Snap-In and Torsion Spring metal panel ceiling systems may be used for protected exterior applications not directly exposed to the weather. Celebration™ Snap-In and Torsion Spring metal panel ceiling systems have been tested for wind load resistance. The two units of measure commonly used are miles per hour (mph) and pounds per square foot (psf), equated by methods in ASCE 7, Minimum Design Loads for Buildings and Other Structures, American Society of Civil Engineers/Structural Engineering Institute (ASCE/SEI).¹

Limitations: The Celebration™ finish is not UV-resistant; therefore, the Celebration™ Snap-In and Torsion Spring metal panel ceiling systems should not be installed where direct exposure to sun or weather will occur, such as fascias or facades. These systems are not suitable for areas subject to high concentrations of acid rain. Indirect exposure to severe environmental conditions may shorten the lifespan of these products. The specific design of exterior ceiling installations requires the review and approval of the architect or engineer of record. For more information refer to *Celebration™ and Panz™ Metal Ceiling Systems*, IC415.

TECHNICAL DATA

-
- The wind pressure is presented in accordance with applicable test standards.
 - The compression posts used for the tests were minimum 1-5/8", 20-gauge steel studs. (maximum length of 24")

GUIDELINES

-
- The building structure from which the Celebration™ Snap-In or Torsion Spring ceiling system is suspended and spaced, as well as the hanger wire, compression posts, or studs used in the assembly, must be capable of withstanding the design loads. For further information on the compression posts see page 50.
 - Heavy duty main tees shall be used.
 - Other materials can be used for compression posts provided the capacity and attachment connections are approved for use by a structural engineer of record.
 - The architect's details must cover the design and location of expansion joints and meet all applicable building code requirements.
 - Arrowhead Reveal Spacers (CA1) shall be installed.

PANEL SIZES

The Celebration™ Snap-In systems presented in this guide can accommodate all available panel sizes. The performance values are not limited to a particular panel size. All available panel sizes will meet the performance values presented.

The Celebration™ Torsion Spring systems presented in this guide can accommodate the following panel sizes: 2ft.x2ft., 2ft.x4ft., 2ft.x6ft., 2ft.x8ft., and 4ft.x4ft.

1. The system shall comply with local wind load requirements. The engineer of record shall determine the final recommendation for the design wind pressure requirements of each project.

For more information about Paraline® linear metal ceiling systems, visit usg.com

METAL PANEL CEILING SYSTEMS

CELEBRATION™ SNAP-IN

System Components

PERIMETER MOLDING

U-2-3/32

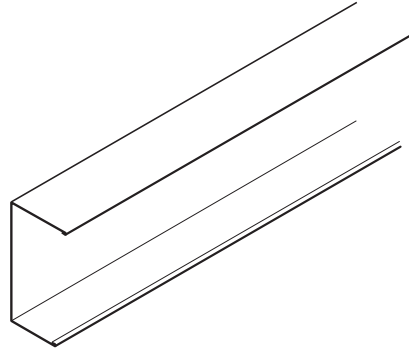
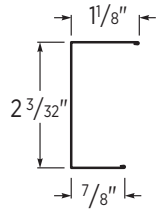

ACCESSORIES

U-2-3/32 Hold-Down Clip

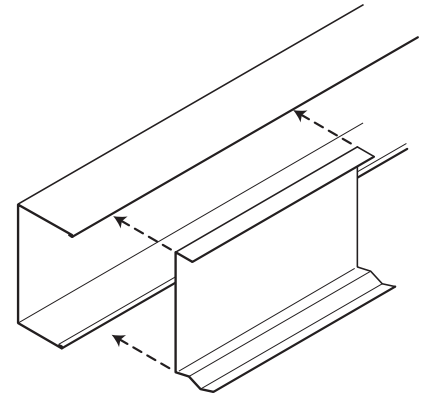
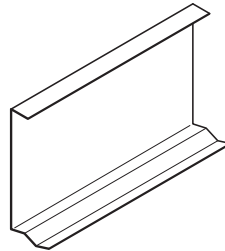
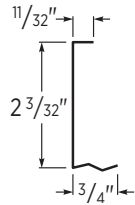

CA1 Arrowhead Reveal Spacer

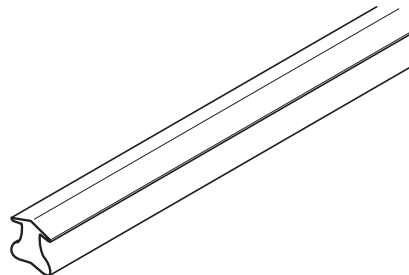
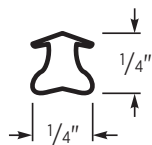

METAL PANEL CEILING SYSTEMS

CELEBRATION™ SNAP-IN

UL 1897

25 psf (Downward Load)

Main Tees: 48 in. o.c.
Cross Tees: 24 in. o.c.
Compression Posts: 24 in. o.c.

- ⊗ Hanger & Compression Post
- DXFEVH2924 (Heavy Duty Main Tee)
- DXFEV429N (48 in. Cross Tee)
- DXFEV229 (24 in. Cross Tee)

Note: Celebration™ Snap-In panels cannot be installed across a main tee and a 4 ft. cross tee.

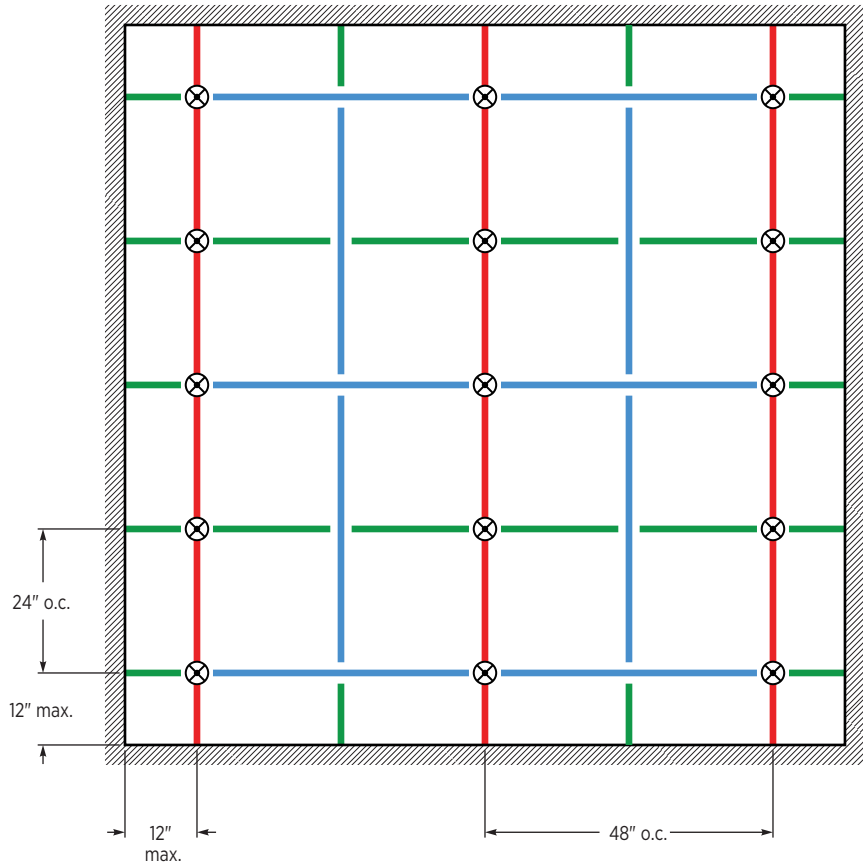

PERIMETER CONDITIONS

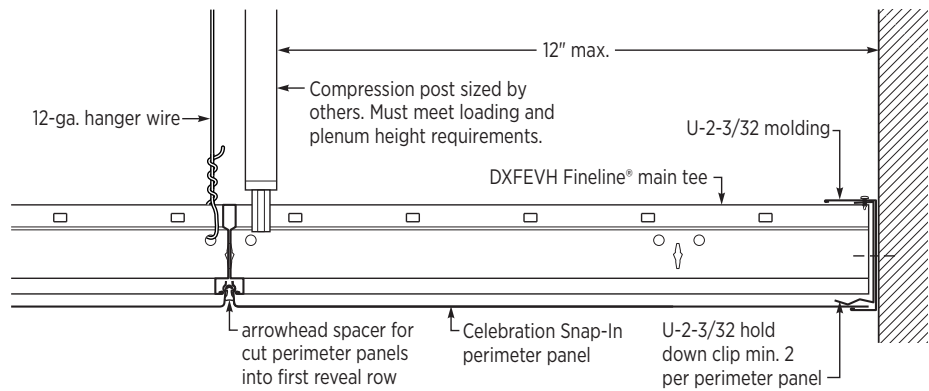

Note: A fastener attachment through the top leg of the molding into the tee bulb is required.

METAL PANEL CEILING SYSTEMS

CELEBRATION™ SNAP-IN

UL 580
Class 90

UL 1897
102 psf

Miami-Dade NOA No. 24-1011.08
176 mph

Main Tees: 24 in. o.c.
Cross Tees: 24 in. o.c.
Compression Posts: 24 in. o.c.

⊗ Hanger & Compression Post

— DXFEVH2924
(Heavy Duty Main Tee)

— DXFEV229 (24 in. Cross Tee)

Note: Celebration™ Snap-In panels cannot be installed across a main tee.

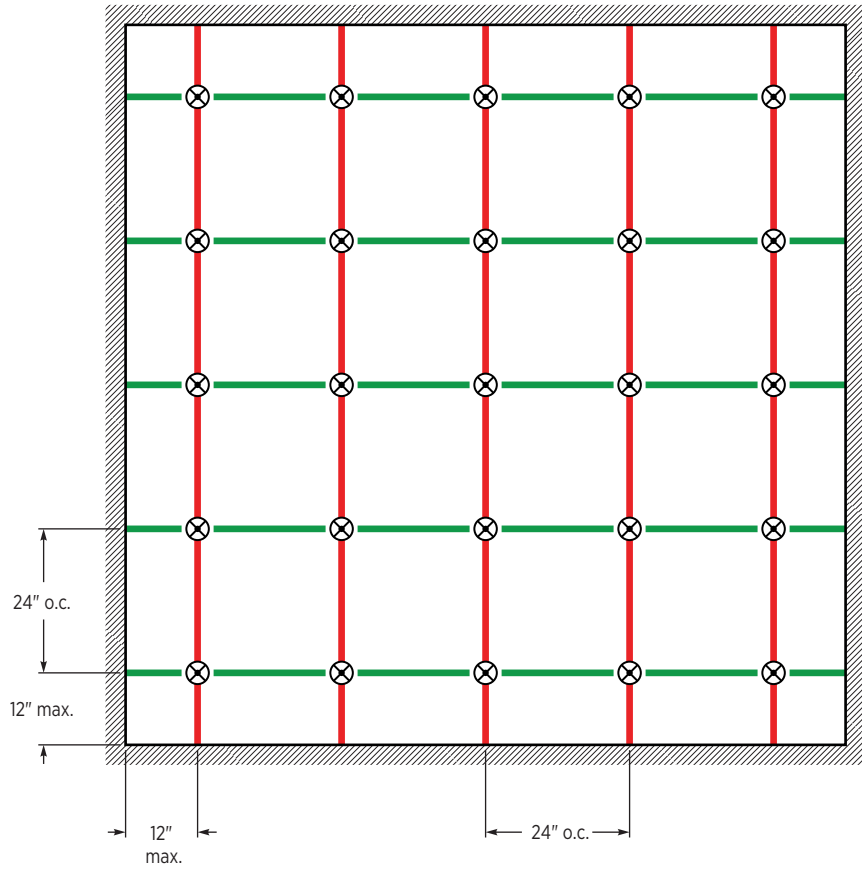

PERIMETER CONDITIONS

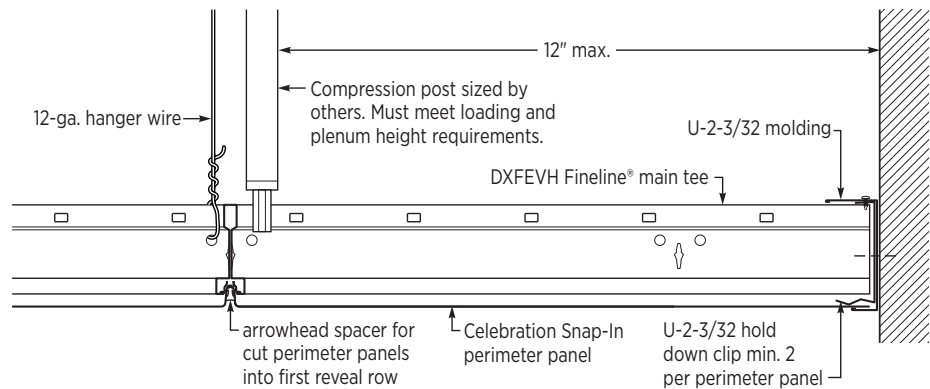

METAL PANEL CEILING SYSTEMS

CELEBRATION™ SNAP-IN

UL 1897
51 psf

Main Tees: 30 in. o.c.
Cross Tees: 30 in. o.c.
Compression Posts: 30 in. o.c.

- ⊗ Hanger & Compression Post
 - DXFEVH2930 (Heavy Duty Main Tee)
 - DXFEV30 (30 in. Cross Tee)¹
- ¹ Special Order

Note: Celebration™ Snap-In panels cannot be installed across a main tee.

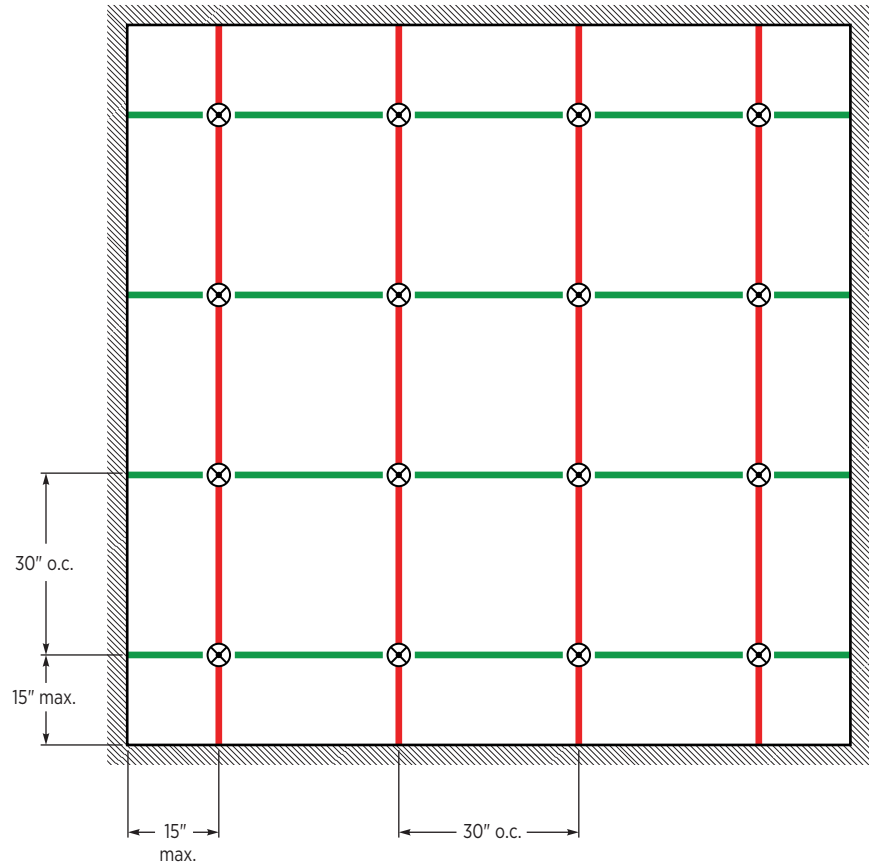

PERIMETER CONDITIONS

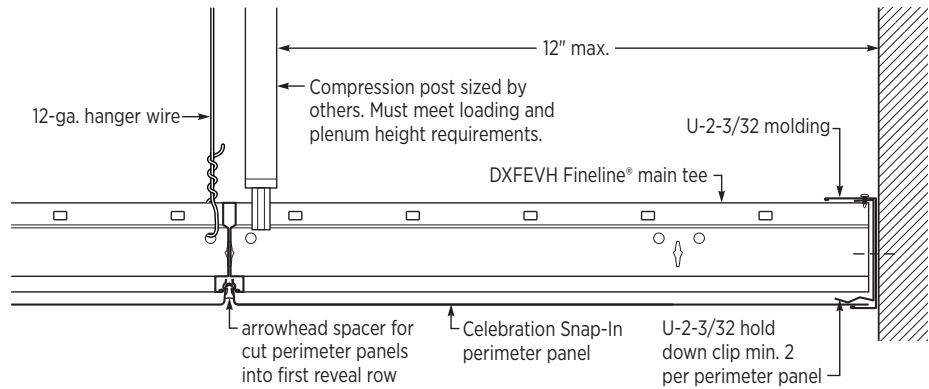

METAL PANEL CEILING SYSTEMS

CELEBRATION™ SNAP-IN

UL 1897
68 psf

UL 580
Class 60

Main Tees: 30 in. o.c.
Cross Tees: 30 in. o.c.
Compression Posts: 30 in. o.c.

- ⊗ Hanger & Compression Post
 - DXFEVH2930 (Heavy Duty Main Tee)
 - DXFEV30 (30 in. Cross Tee)¹
- ¹ Special Order

Note: Celebration™ Snap-In panels cannot be installed across a main tee.

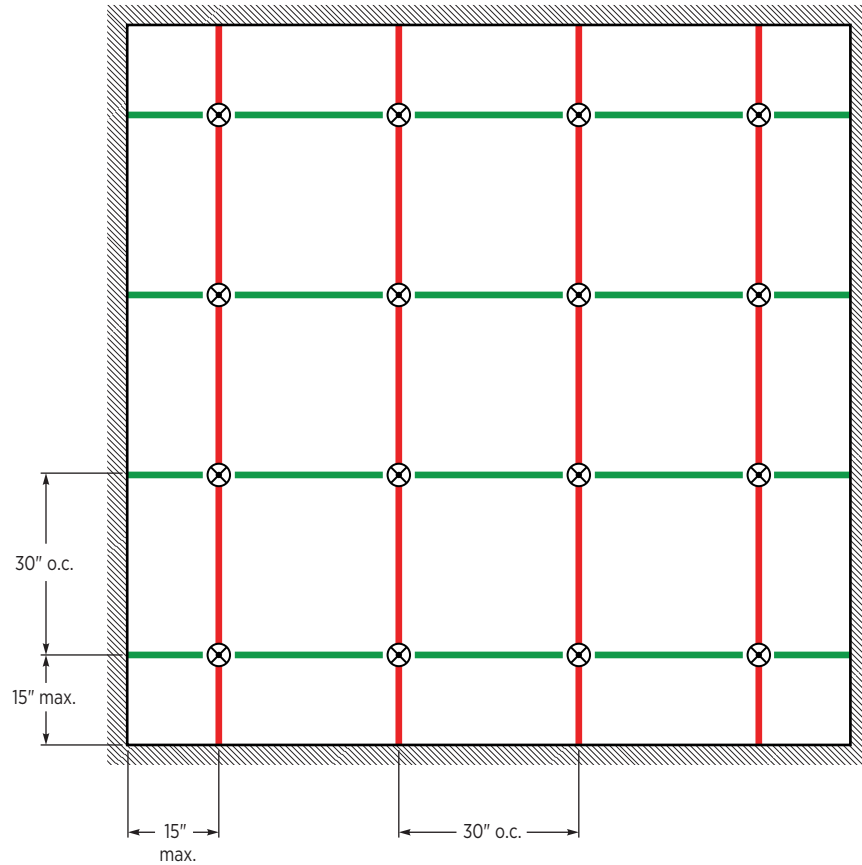

PERIMETER CONDITIONS

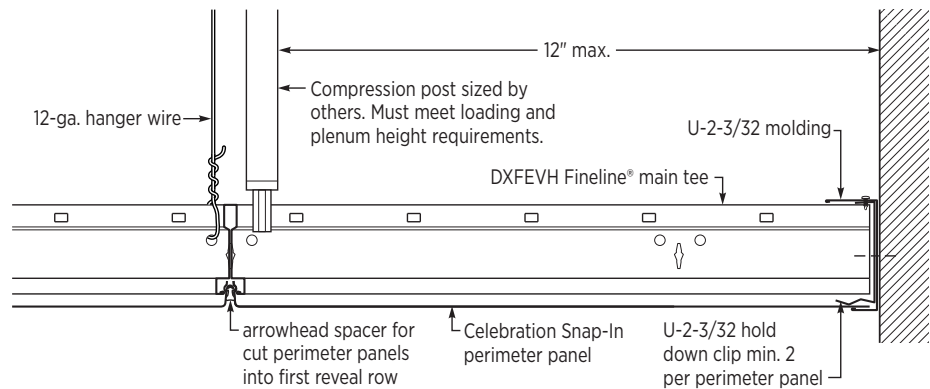

METAL PANEL CEILING SYSTEMS

CELEBRATION™ TORSION SPRING

System Components

PERIMETER MOLDING

Option 1 Two Layers of M7Z

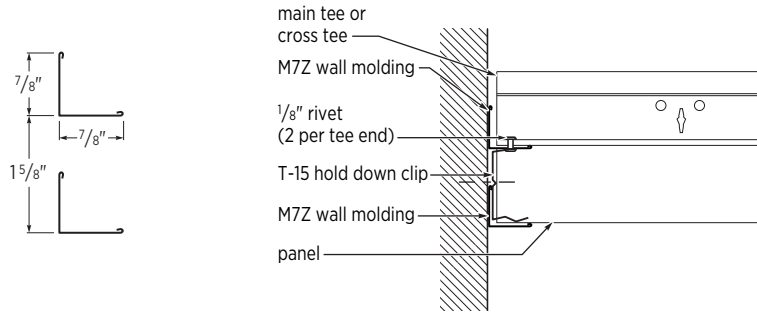

Option 2 CTS15AL Perimeter Molding

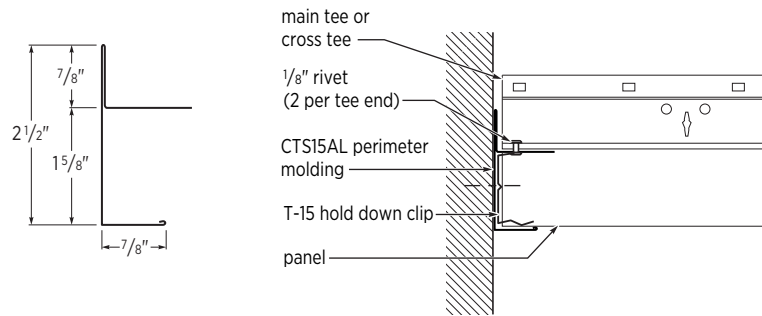

ACCESSORIES

T15 Hold-Down Clip

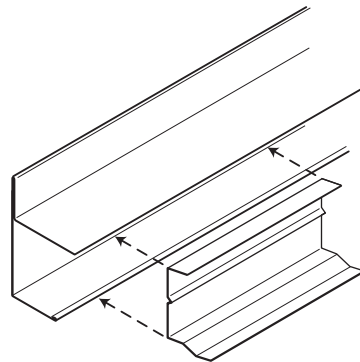
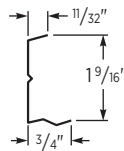

METAL PANEL CEILING SYSTEMS

CELEBRATION™ TORSION SPRING

UL 580
Class 90

UL 1897
133 psf

Miami-Dade NOA No. 24-1011.10
170 mph

Main Tees: 24 in. o.c.
Cross Tees: 24 in. o.c.
Compression Posts: 24 in. o.c.
Panel Sizes: 2 ft. x 2 ft. and
 2 ft. x 4 ft.

- ⊗ Hanger & Compression Post
- ZXLA™26 (Heavy Duty Main Tee)
- TSCT22ZX (24 in. Cross Tee)

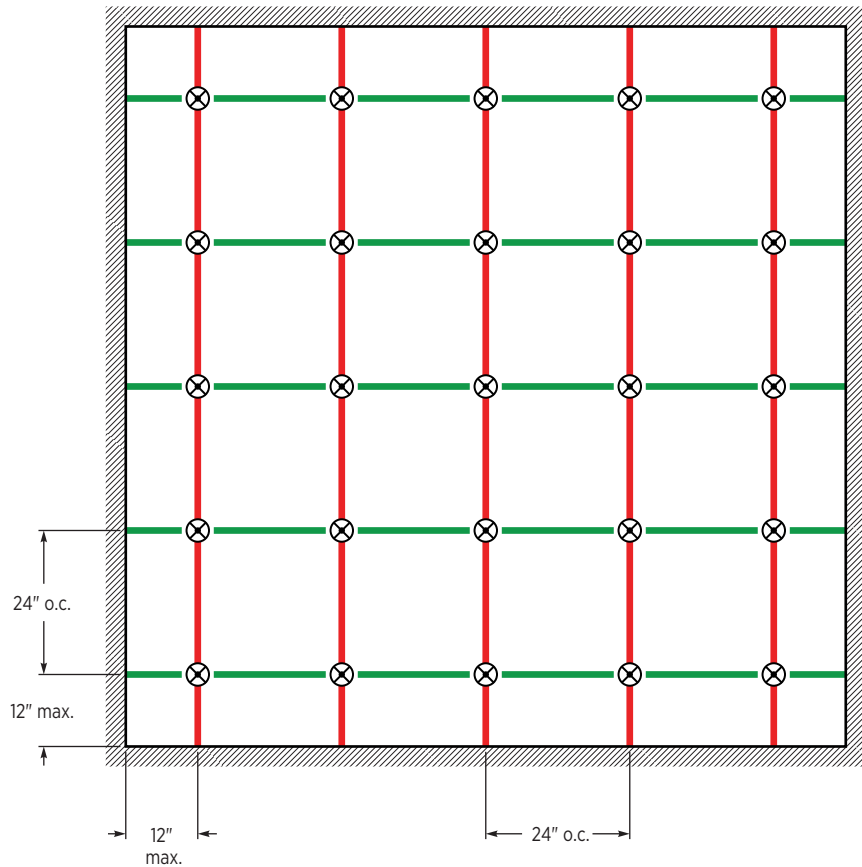

COMPRESSION POST DETAILS

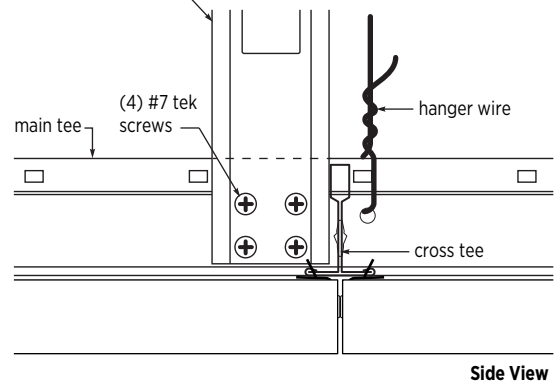
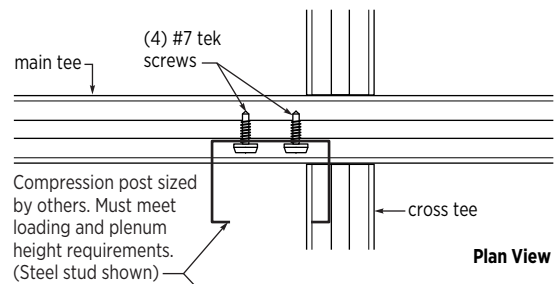
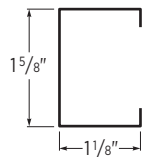

METAL PANEL CEILING SYSTEMS

CELEBRATION™ TORSION SPRING

UL 580 Class 30

Main Tees: 48 in. o.c.
Cross Tees: 24 in o.c.
Compression Posts: 48 in. o.c.
Panel Sizes: 2 ft. x 4 ft. and
 2 ft. x 8 ft.

- ⊗ Hanger & Compression Post
- ZXLA™26 (Heavy Duty Main Tee)
- TSCT44ZX (48 in. Cross Tee)

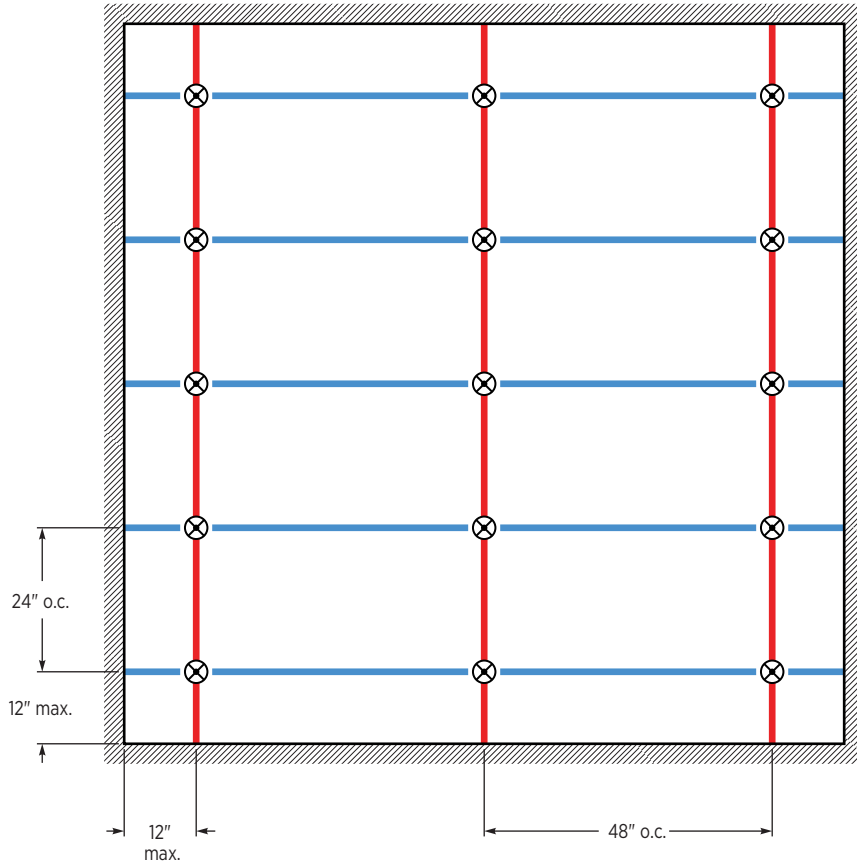

COMPRESSION POST DETAILS

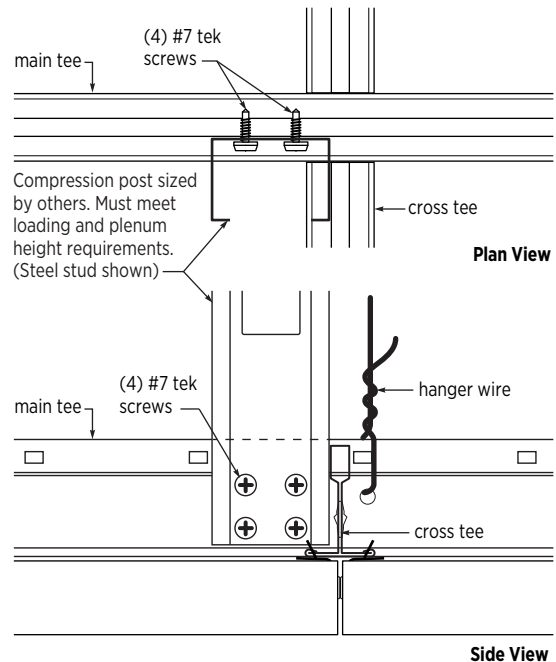
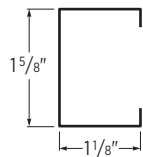

METAL PANEL CEILING SYSTEMS

CELEBRATION™ TORSION SPRING

UL 580 Class 30

Main Tees: 72 in. o.c.
Cross Tees: 24 in o.c.
Compression Posts: 24 in. o.c.
Panel Size: 2 ft. x 6 ft.

- ⊗ Hanger & Compression Post
- ZXLA™26 (Heavy Duty Main Tee)
- TSCT66ZXA (72 in. Cross Tee)
- ZXLA224 (24 in. Cross Tee)

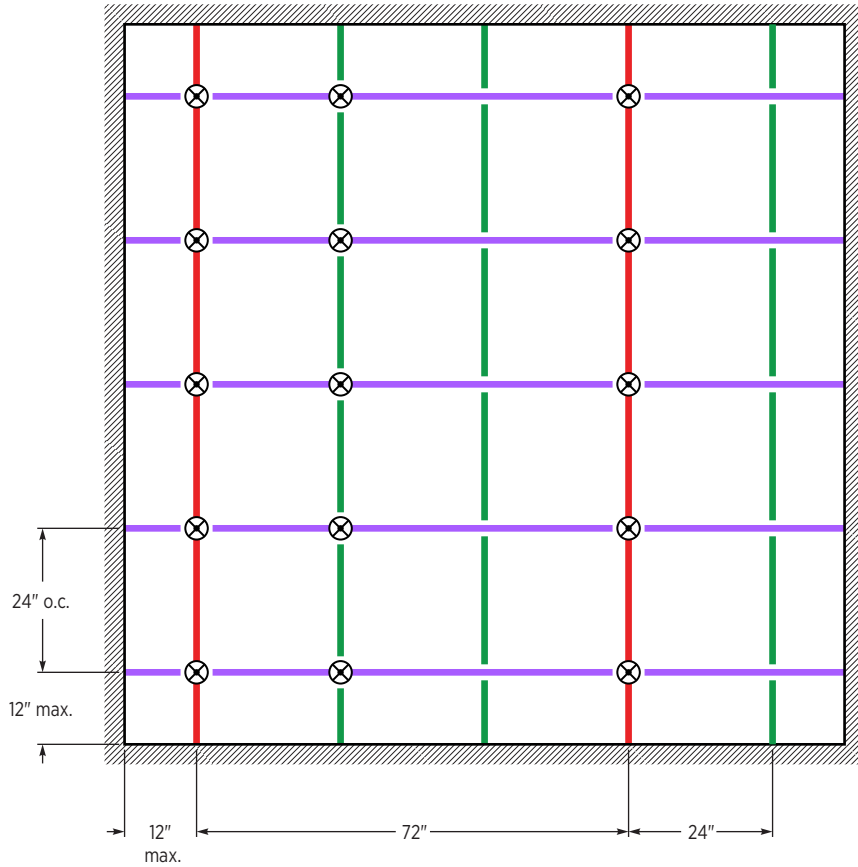

COMPRESSION POST DETAILS

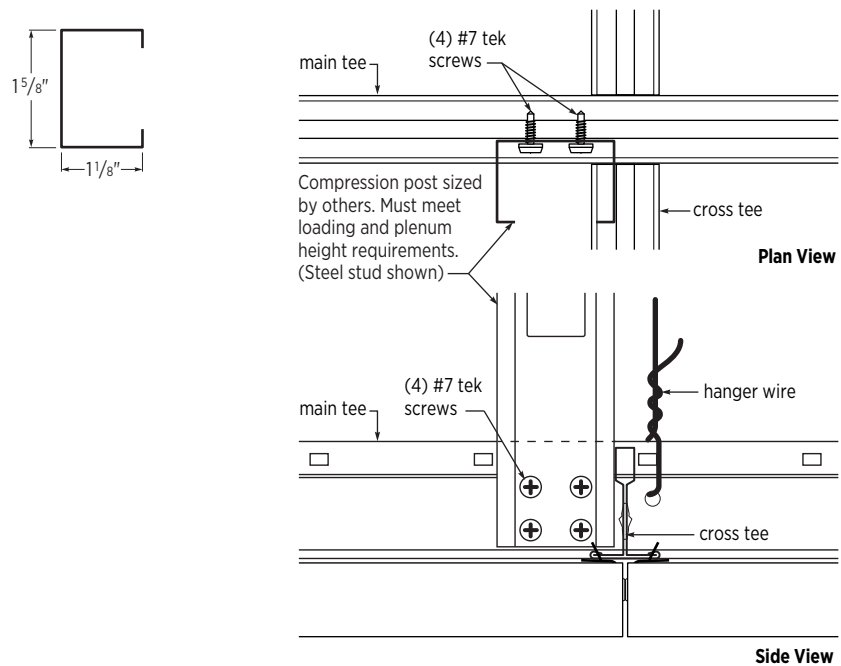

METAL PANEL CEILING SYSTEMS

CELEBRATION™ TORSION SPRING

UL 580 Class 15

Main Tees: 48 in. o.c.
Cross Tees: 24 in o.c.
Compression Posts: 48 in. o.c.
Panel Size: 4 ft. x 4 ft.

- ⊗ Hanger & Compression Post
- ZXLA™26 (Heavy Duty Main Tee)
- TSCT44ZX (48 in. Cross Tee)

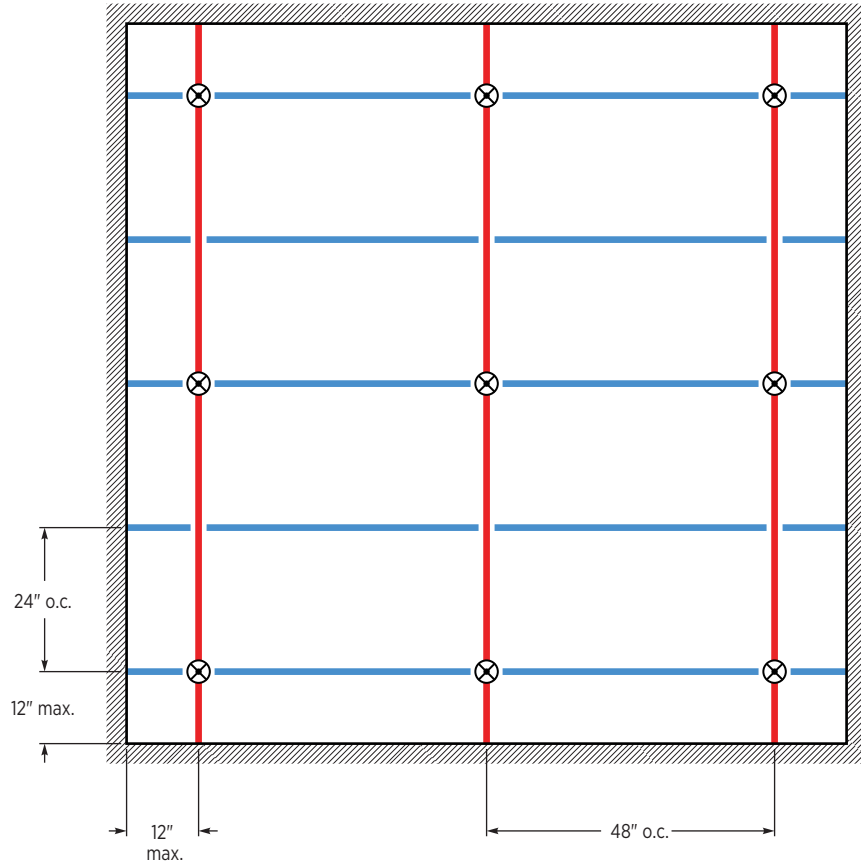

COMPRESSION POST DETAILS

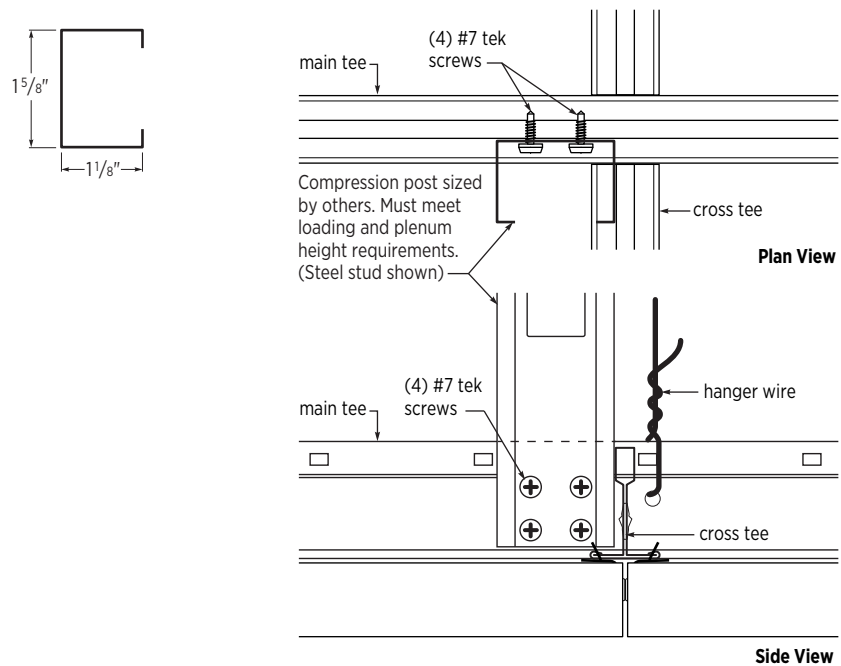

METAL PANEL CEILING SYSTEMS

CELEBRATION™ TORSION SPRING

UL 1897

13 psf (Downward Load)

Main Tees: 24 in. o.c.
Cross Tees: 24 in. o.c.
Compression Posts: 24 in. o.c.
Panel Size: 2 ft. x 2 ft.

- ⊗ Hanger & Compression Post
- ZXLA™26 (Heavy Duty Main Tee)
- TSCT22ZX (24 in. Cross Tee)

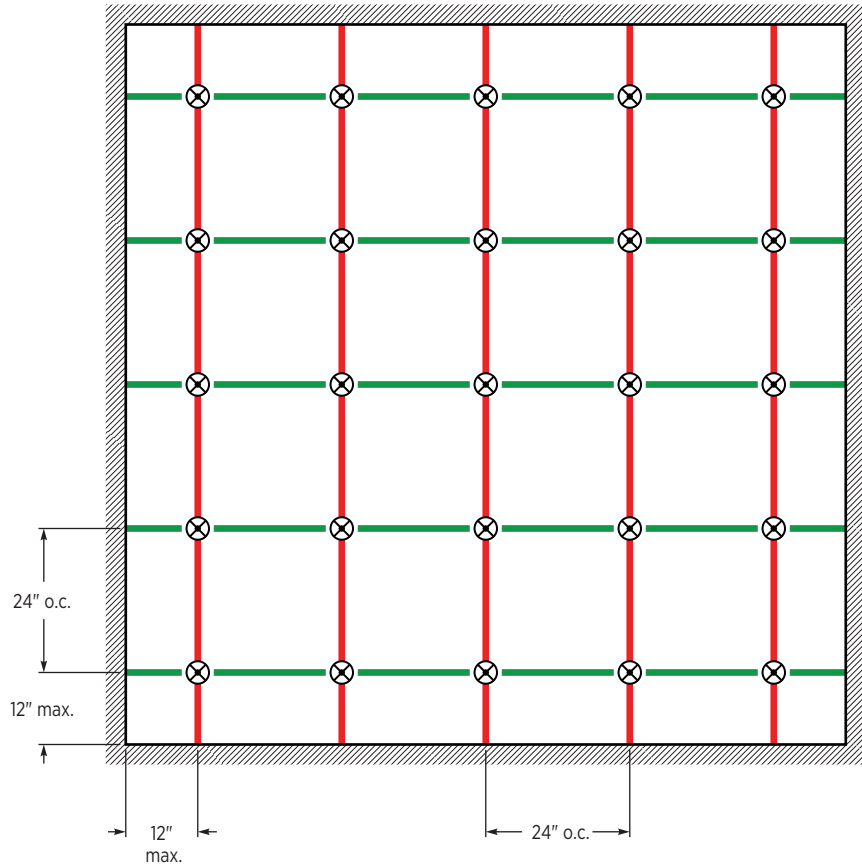

COMPRESSION POST DETAILS

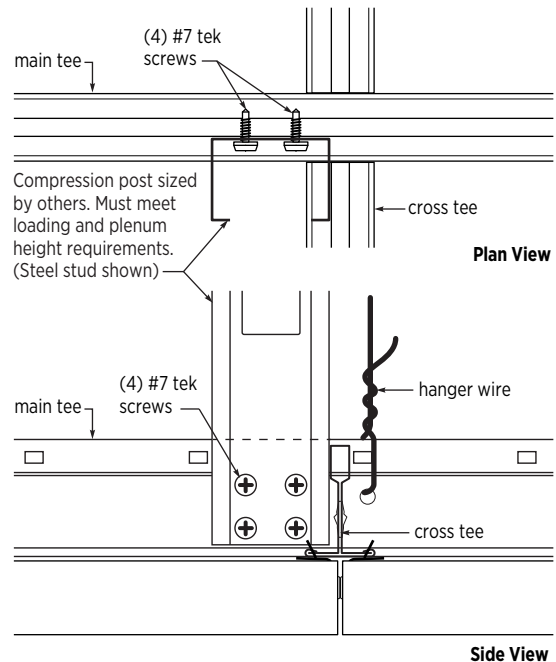
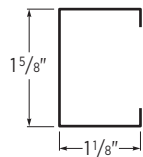

PAGE 38 INTENTIONALLY LEFT BLANK.

USG SHEETROCK® BRAND LAY-IN CEILING PANELS (GLIP) ZXLA™

ZXLA™ AND GLIP

Technical Data

Main Tee	All Acceptable Panel Sizes (Inch)	Main Tee Spacing (Inch)	Cross Tee Spacing (Inch)	Compression Post Spacing (Inch)	Test Standard	Maximum Load Rating (psf)		Equivalent Wind Speed mph (kph)
						Uplift psf (kPa)	Downward psf (kPa)	
ZXLA26	24 x 48	48	24	24	UL 1897 ¹	25 (1.20)	-13 (-0.62)	100 (161)
	24 x 24	48	24	24	UL 1897 ¹	21 (1.01)		90 (145)
	24 x 48	24	48	24	UL 1897 ¹	85 (4.07)	-68 (-3.25)	182 (293)

1. Factor of safety of 1.17 is included



USG SHEETROCK® BRAND LAY-IN PANEL (GLIP) WITH ZXLA™

2 FT. x 2 FT. AND 2 FT. x 4 FT. SYSTEMS

WIND RESISTANCE

USG ZXLA™ Suspension Systems with USG Sheetrock® Brand Lay-In Ceiling Panels may be used for sheltered exterior applications not directly exposed to the weather. These systems have been tested for wind load resistance. The two units of measure commonly used are miles per hour (mph) and pounds per square foot (psf), equated by methods in ASCE 7, Minimum Design Loads for Buildings and Other Structures, American Society of Civil Engineers/Structural Engineering Institute (ASCE/SEI).¹

Limitations: This system should not be installed where direct exposure to sun or weather will occur, such as fascias or facades. This system is not suitable for areas subject to high concentrations of acid rain. Indirect exposure to severe environmental conditions may shorten the lifespan of the product. The specific design of exterior ceiling installations requires the review and approval of the architect or engineer of record.

TECHNICAL DATA

- The wind pressure is presented in accordance with applicable test standards.
- Compression posts used for the tests or minimum 1-5/8 in., 20-gauge steel studs (maximum length of 24 in.).
Refer to Compression Post page 50

AVAILABLE PANELS

USG Sheetrock® Brand Lay-In Ceiling Panel, Vinyl	Edge	Panel Size	Item No.
	Square	2' x 2' x 1/2"	3260
	Square	2' x 4' x 1/2"	3270

GUIDELINES

- The building structure from which the USG Sheetrock® Brand Lay-In Ceiling Panel system is suspended and spaced, as well as hanger wire and compression post attachment methods, must be capable of withstanding the loads applied during wind conditions.
- Other materials can be used for compression posts if the compressive strength and attachment method are approved for use by a local structural engineer.
- A minimum of 16d common hold-down nails or similar devices shall be installed at regular intervals to prevent uplift. A minimum of six for each 2 ft. x 4 ft. panel module and a minimum of four for each 2 ft. x 2 ft. panel module are required.
- A minimum of 16d common hold-down nails or similar devices shall be inserted in alternating directions.
- A minimum of 16d common hold-down nails or similar devices may be installed through the hanger wire holes, cross tee clip holes, and through a field-punched hole in the web of the tee.
- The architect's details must cover the design and location of expansion joints and meet all applicable building code requirements.

1. The system shall comply with local wind load requirements. The engineer of record shall determine the final recommendation for the design wind pressure requirements of each project.

USG SHEETROCK® BRAND LAY-IN PANEL (GLIP) WITH ZXLA™

2 FT. x 4 FT. SYSTEMS

UL 1897
26 psf

Main Tees: 48 in. o.c.
Cross Tees: 24 in. o.c.
Compression Posts: 24 in. o.c.

- ⊗ Hanger & Compression Post
- ZXLA26 (Heavy Duty Main Tee)
- ZXLA424 (48 in. Cross Tee)
- Hold-Down Nail

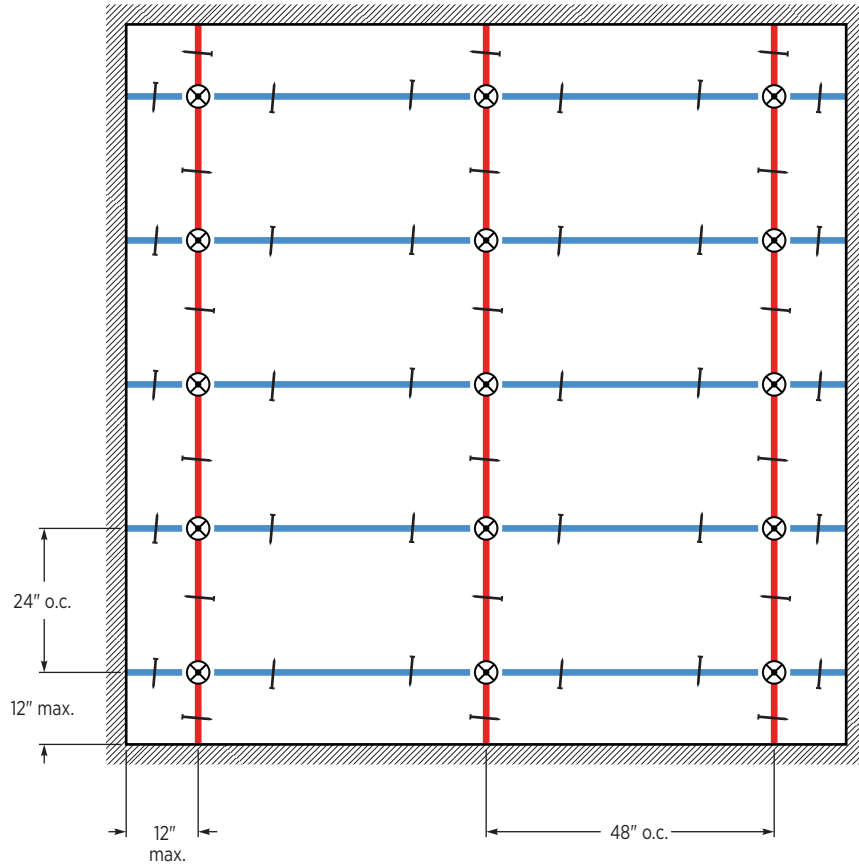

PERIMETER CONDITIONS

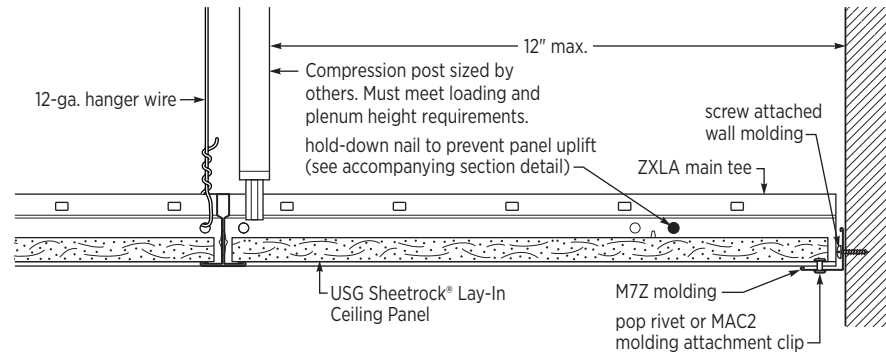

HOLD-DOWN NAIL

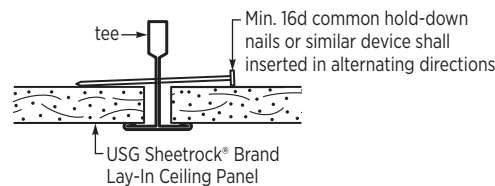

Note: Pop rivets are suitable for exterior use.

USG SHEETROCK® BRAND LAY-IN PANEL (GLIP) WITH ZXLA™

2 FT. x 4 FT. SYSTEMS

UL 580
Class 30

Main Tees: 24 in. o.c.
Cross Tees: 48 in o.c.
Compression Posts: 24 in. o.c.

- ⊗ Hanger & Compression Post
- ZXLA26 (Heavy Duty Main Tee)
- ZXLA224 (24 in. Cross Tee)
- Hold-Down Nail

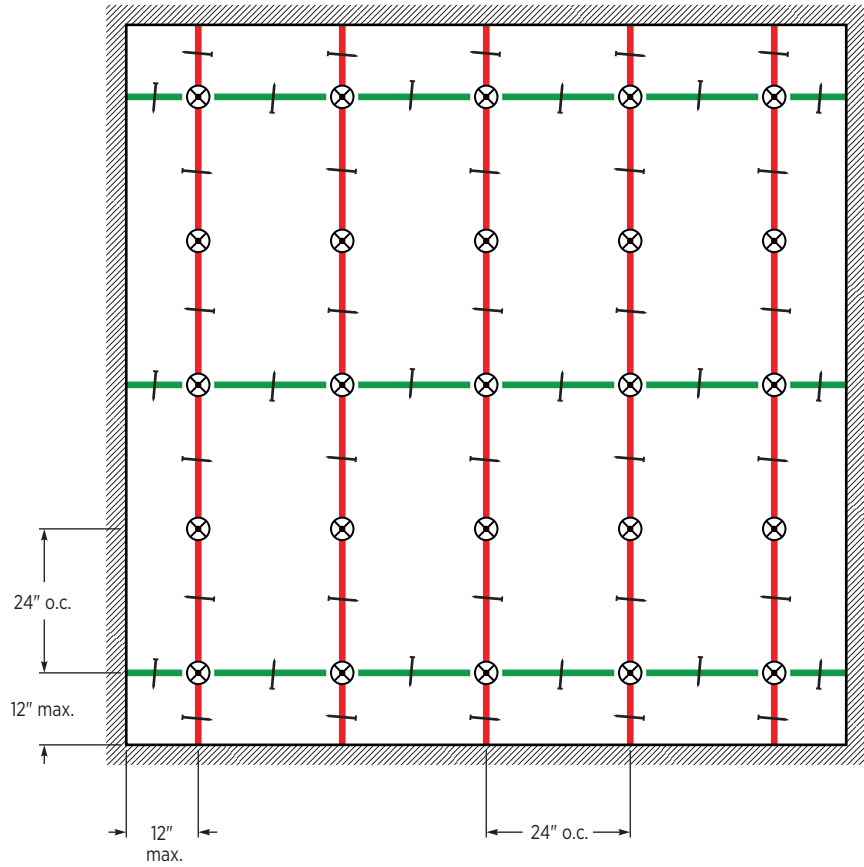

PERIMETER CONDITIONS

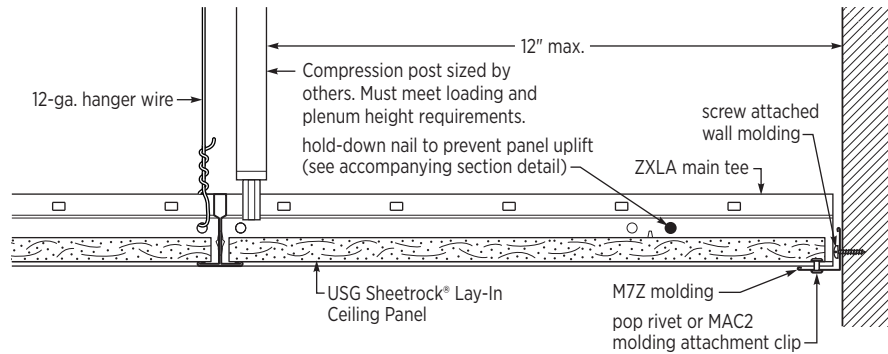

HOLD-DOWN NAIL

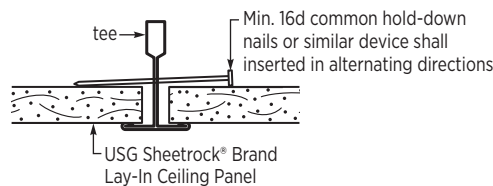

Note: Pop rivets are suitable for exterior use.

USG SHEETROCK® BRAND LAY-IN PANEL (GLIP) WITH ZXLA™

2 FT. x 2 FT. SYSTEMS

UL 1897

21 psf

Main Tees: 48 in. o.c.
Cross Tees: 24 in. o.c.
Compression Posts: 24 in. o.c.

- ⊗ Hanger & Compression Post
- ZXLA26 (Heavy Duty Main Tee)
- ZXLA424 (48 in. Cross Tee)
- ZXLA224 (24 in. Cross Tee)
- Hold-Down Nail

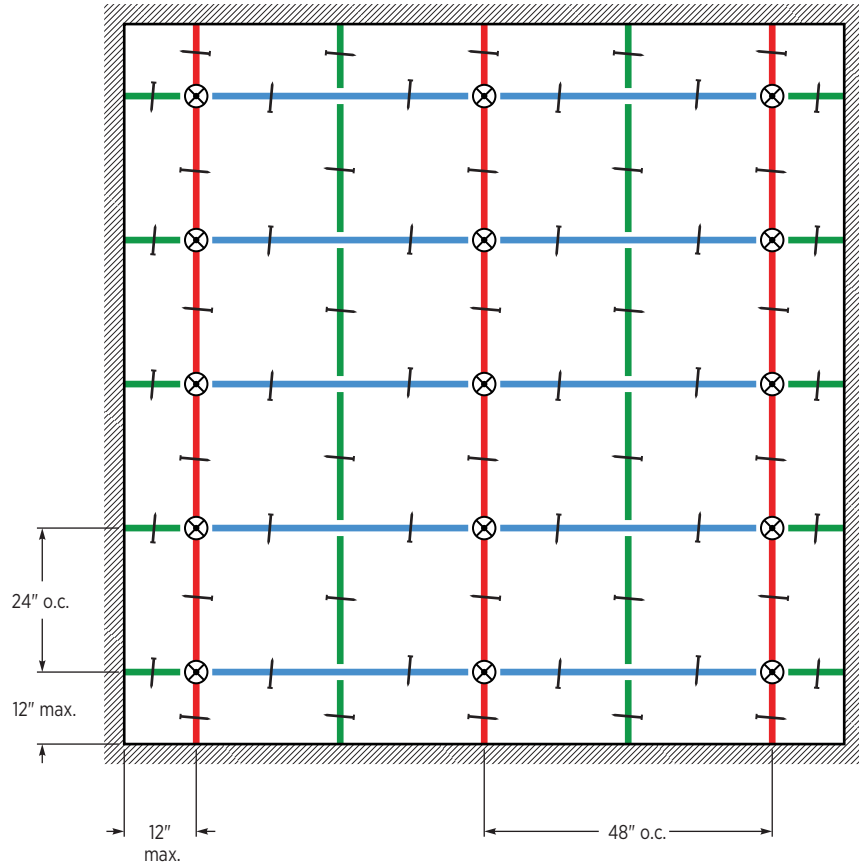

PERIMETER CONDITIONS

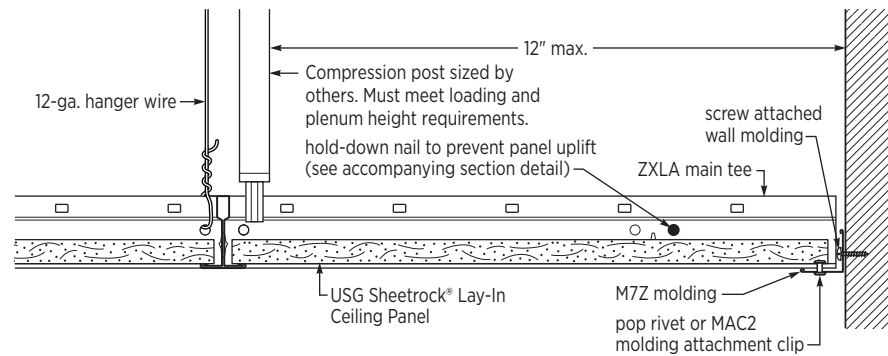

HOLD-DOWN NAIL

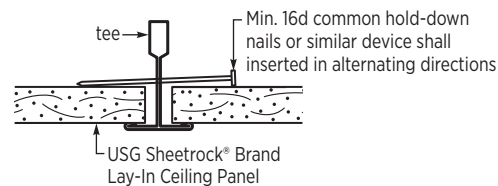

Note: Pop rivets are suitable for exterior use.

USG SHEETROCK® BRAND LAY-IN PANEL (GLIP) WITH ZXLA™

2 FT. x 4 FT. SYSTEMS

UL 1897

85 psf

Main Tees: 24 in. o.c.
Cross Tees: 48 in o.c.
Compression Posts: 24 in. o.c.

- ⊗ Hanger & Compression Post
- ZXLA26 (Heavy Duty Main Tee)
- ZXLA224 (24 in. Cross Tee)
- Hold-Down Nail

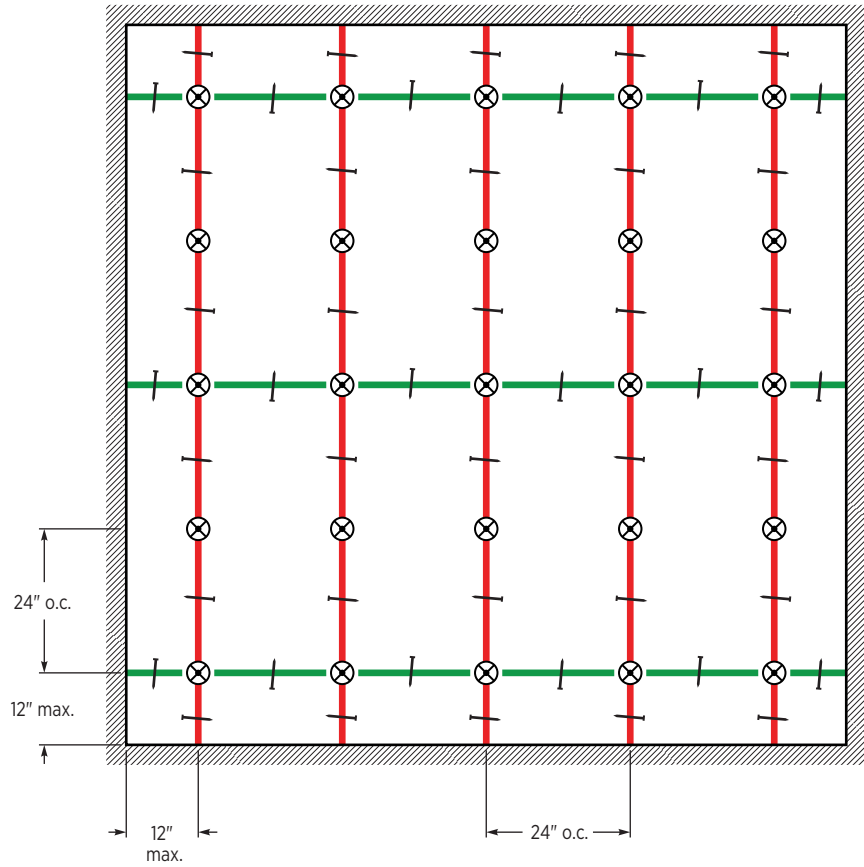

PERIMETER CONDITIONS

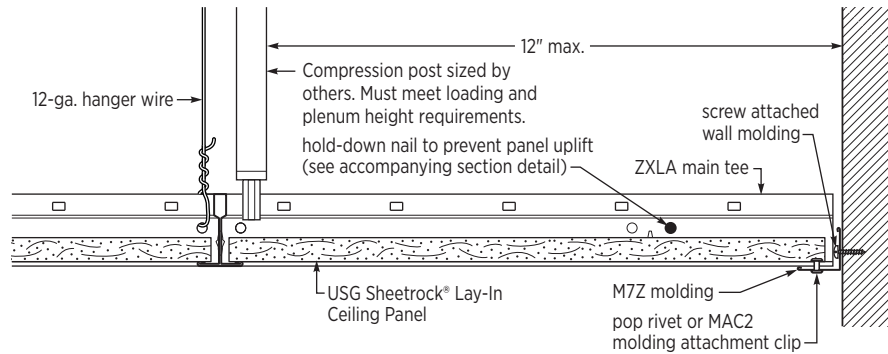

HOLD-DOWN NAIL

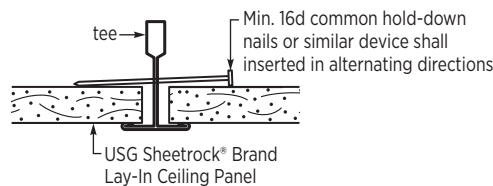

Note: Pop rivets are suitable for exterior use.

USG DRYWALL SUSPENSION SYSTEM

DGLW26E

NOA. No. 24-1011.07

Technical Data

Main Tee	All Acceptable Panel Sizes (Inch)	Main Tee Spacing (Inch)	Cross Tee Spacing (Inch)	Compression Post Spacing (Inch)	Test Standard	Maximum Load Rating (psf)		Equivalent Wind Speed mph (kph)
						Uplift psf (kPa)	Downward psf (kPa)	
DGLW26E	See note 4 below	24	16	24	Miami Dade NOA TAS 202 & 203 ³	75 (3.59)	-75 (-3.59)	171 (275)
	1 layer of 5/8"	48	24	24	UL 580 ²	15 (0.72)		77 (124)
	1 layer of 1/2"	48	16	30	UL 580 ²	15 (0.72)		77 (124)
	1 layer of 5/8"	48	24	30	UL 580 ²	15 (0.72)		77 (124)
	1 layer of 5/8"	24	24	30	UL 580 ²	30 (1.44)		108 (174)
	2 layers of 5/8"	24	24	42	UL 580 ²	60 (2.87)		153 (246)
	2 layers of 5/8"	24	24	30	UL 580 ²	90 (4.31)		188 (302)
	3/8" plywood and 5/8" drywall	24	16	24	UL 580 ²	90 (4.31)		188 (302)

- Factor of safety of 1.17 is included
- Factor of safety of 1.5 for 30 psf; 1.3 for 60 psf; 1.17 for 90 psf is included per test standard
- Factor of safety of 1.5 is included per test standard
- Min 1/2" Securock® Brand Glass Mat sheathing or
Min 1/2" Securock® Brand UltraLight Glass Mat Sheathing



DRYWALL AND DWSS

USG DRYWALL SUSPENSION SYSTEM

WIND RESISTANCE FOR EXTERIOR SOFFITS

The USG Drywall Suspension System may be used for protected exterior applications not directly exposed to weather. The system has been tested using applicable industry standards for wind resistance when installed in exterior soffits and canopies. For more information regarding test standards and online resources, please refer to the Systems Overview section of this guide.

Only USG Securock® Brand UltraLight Glass-Mat Sheathing is suitable for exterior applications. Refer to Securock® Brand submittal and installation instructions for more information.

WIND RESISTANCE FOR EXTERIOR SOFFITS

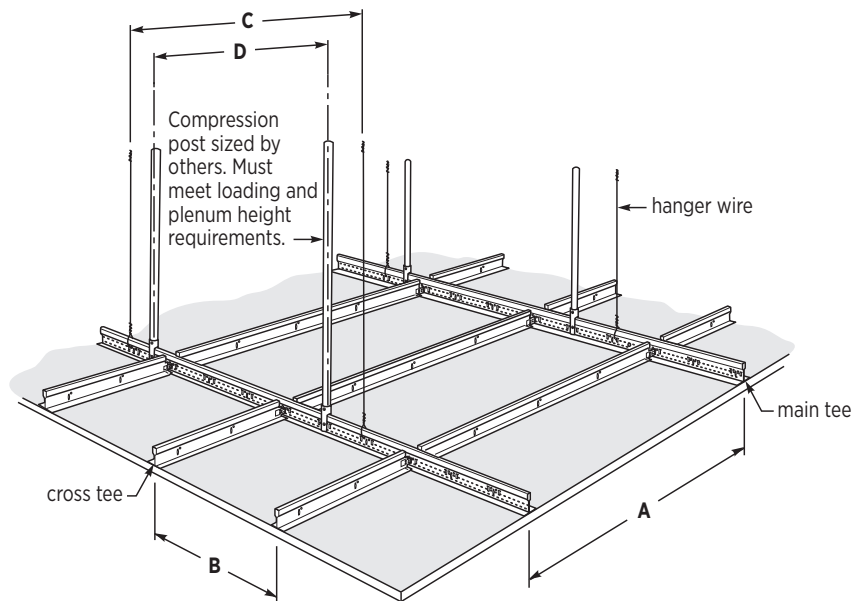

OTHER CONSIDERATIONS

Finishes

Compression Posts

Seismic Perimeter Applications



FINISHES

Selector

USG offers a wide selection of colors and finishes suitable for linear metal and metal panels in exterior applications. Available in painted and anodized finishes.

Painted: Flat White, Silver Satin

Anodized: Satin Chrome

Timbre™: Maple, VG Fir, Red Birch, Golden Glow Oak, Walnut, Roasted Chestnut, Cherry, Mahogany, Driftwood

Sarante®: CP Maple, Red Birch, Sable Walnut, Natural Walnut

Additional finish options may be available to meet specific project requirements or coating specifications. Contact your USG representative for more information.

PAINTED METALS

Flat White
050

Silver Satin
002

Blanco Mat®
4182
(Celebration Snap-In,
Celebration Torsion Spring
& Planx™ Universal)

Matte Black
(Planx™ Universal)

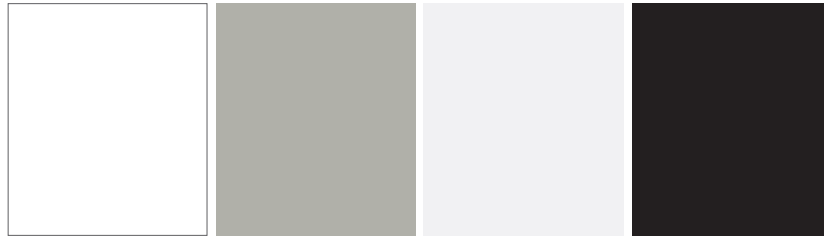

ANODIZED METALS

Paraline® II not available
in Satin Chrome (PM614)
(2' x 2' panels)

Satin Chrome
PM614



TIMBRE™
(Planx™ Universal,
Paraline® Plus and
Celebration™ Snap-In)

Maple
4010

VG Fir
4011

Red Birch
4012

Golden Glow Oak
4198

Walnut
4014

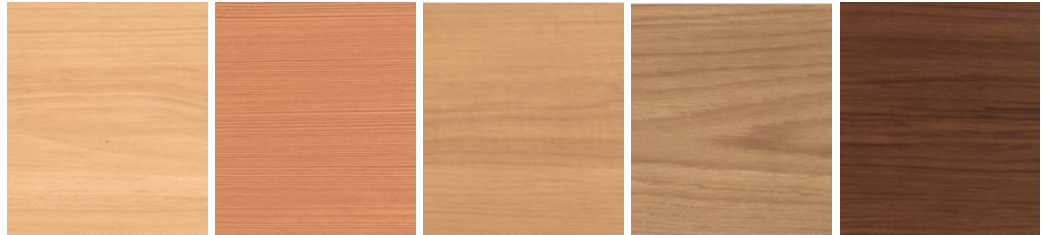

Roasted Chestnut
4197

Cherry
4013

Mahogany
4015

Driftwood
4199

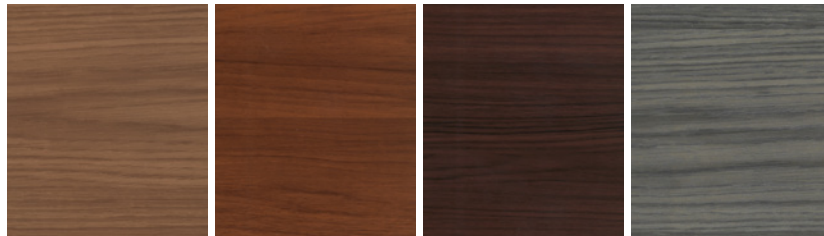

FINISHES

Selector

SARANTE®
Planx™ Universal

CP Maple S-32



Red Birch S-13



Sable Walnut S-18

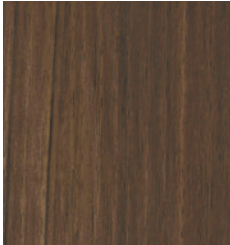

Natural Walnut S-38

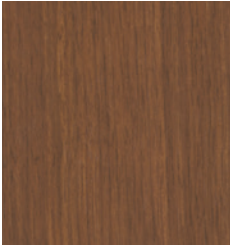

COMPRESSION POSTS

PARALINE® II COMPRESSION POSTS

EMT conduit is best used with USG Paraline® II. USG Paraline® II adapter is inserted into EMT conduit and into symmetrical carrier.

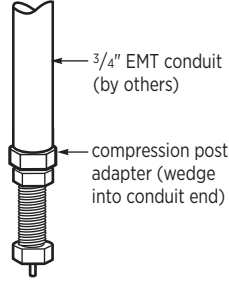
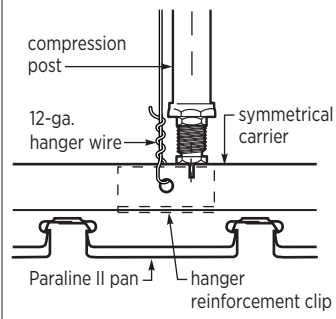
Paraline® II Compression Post Adapter	Paraline® II Compression Post Adapter in Conduit	Paraline® II Compression Post Application
	 <p>3/4" EMT conduit (by others)</p> <p>compression post adapter (wedge into conduit end)</p>	 <p>compression post</p> <p>12-ga. hanger wire</p> <p>symmetrical carrier</p> <p>Paraline II pan</p> <p>hanger reinforcement clip</p>

Note

When used with symmetrical carriers, compression post adapters must be purchased. The end plug of the compression post is removed and replaced with the adapter prior to installation. The Paraline® II compression post adapter is not included with the compression post and must be purchased separately.

STEEL FRAMING COMPRESSION STRUTS

Steel members with sufficient strength are allowed by code and may be suitable for use as a compression post. Below are some common, light-gauge steel members provided by others that are typically used as compression posts.

Uplift Class / Maximum Pressure	Maximum Length (in.)	Compression Post
Class 15 & Class 30 / 30 psf	96	Min. 1-5/8 in. — 20-ga. stud
		Min. 1-5/8 in. — 20-ga. track
Class 60 / 60 psf	48	Min. 1-5/8 in. — 20-ga. stud
		Min. 1-5/8 in. — 20-ga. track
	96	Min. 2-1/2 in. — 20-ga. stud back to back
		Min. 2-1/2 in. — 20-ga. stud back to back
Class 90 / 150 psf	48	Min. 1-5/8 in. — 20-ga. stud
		Min. 1-5/8 in. — 20-ga. track
	96	Min. 2-1/2 in. — 20-ga. stud back to back
		Min. 2-1/2 in. — 20-ga. stud back to back

Notes

1. The information provided is for quick reference only. Other restrictions and exemptions may apply.
2. All struts and allowable lengths should be verified by a design professional before use.
3. A structural engineer should be consulted for lengths greater than 8 ft.
4. Larger posts can be used; however, the compression post properties listed above shall be considered minimums.
5. The compression post must be attached to the grid member with at least four #8 screws.
6. The compression post attachment to the structure shall be determined by the engineer of record.

SEISMIC PERIMETER APPLICATIONS

PARALINE® II

PERIMETER CONDITIONS¹

Floating

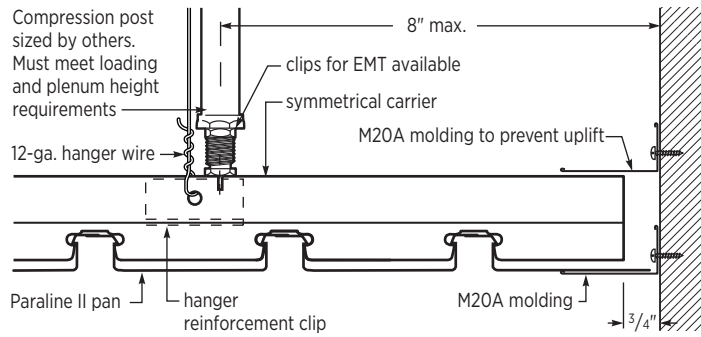

Fixed

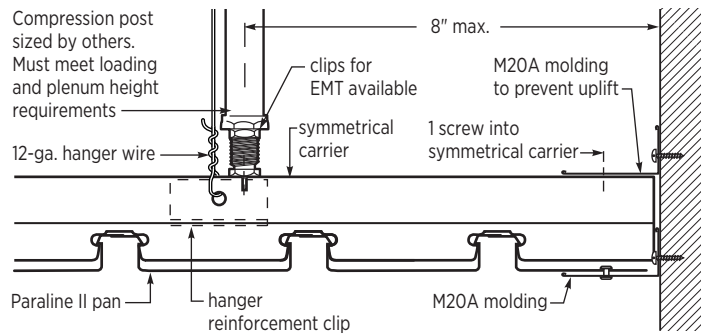

Note: A 3/4 in. gap is shown for typical seismic design categories D-F. Seismic design category C projects shall be constructed to satisfy seismic design category D-F, as illustrated.

1. Other seismic detailing in the field of the system may be required. Typically, the requirements for compression strut under wind loads are more stringent than those for seismic loads; however, there may be some exceptions. Please contact your representative or visit usg.com for more information.

SEISMIC PERIMETER APPLICATIONS

PLANX™ UNIVERSAL

OPTIONAL REVEAL PERIMETER CONDITIONS¹

Perimeter Floating Side - Along Main Tee

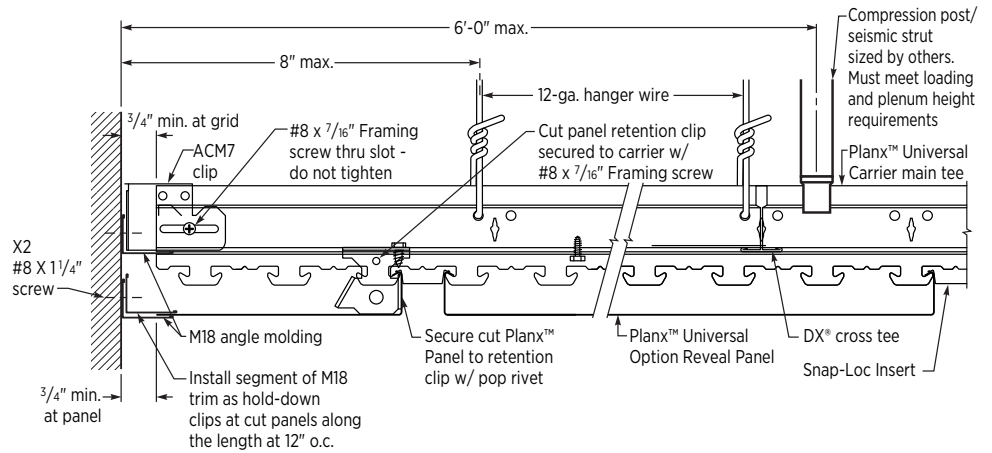

Perimeter Floating Side - Along Cross Tee

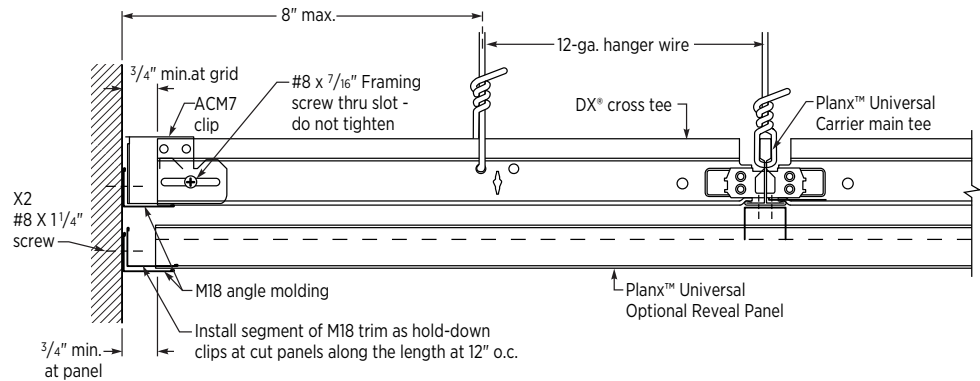

1. Consult the local code officials or engineer of record having jurisdiction over the project.

SEISMIC PERIMETER APPLICATIONS

PLANX™ UNIVERSAL

OPTIONAL REVEAL PERIMETER CONDITIONS¹

Perimeter Fixed Side - Along Main Tee

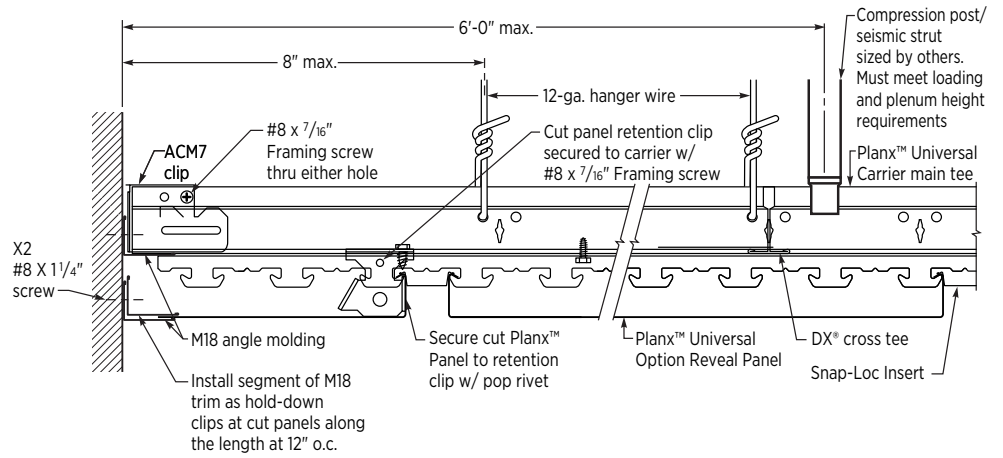

Perimeter Fixed Side - Along Cross Tee

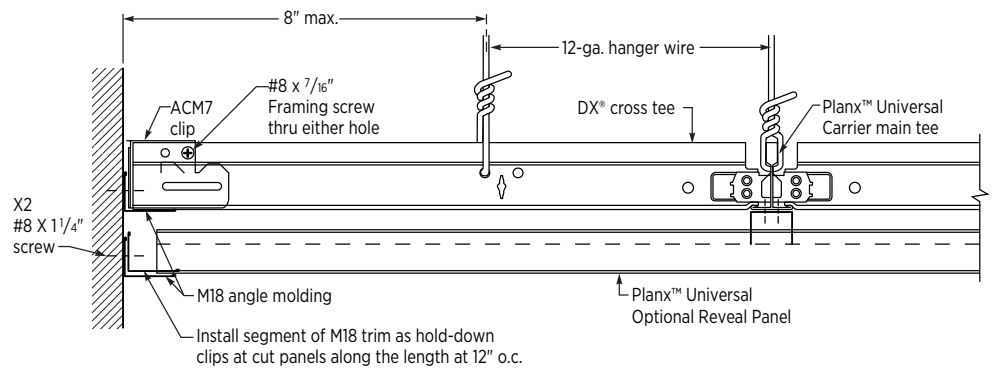

1. Consult the local code officials or engineer of record having jurisdiction over the project.

SEISMIC PERIMETER APPLICATIONS

PLANX™ UNIVERSAL

**OPTIONAL REVEAL
LATERAL FORCE
BRACING (LFB)¹**

Lateral Force Bracing (LFB) Detail - Along Main Tee

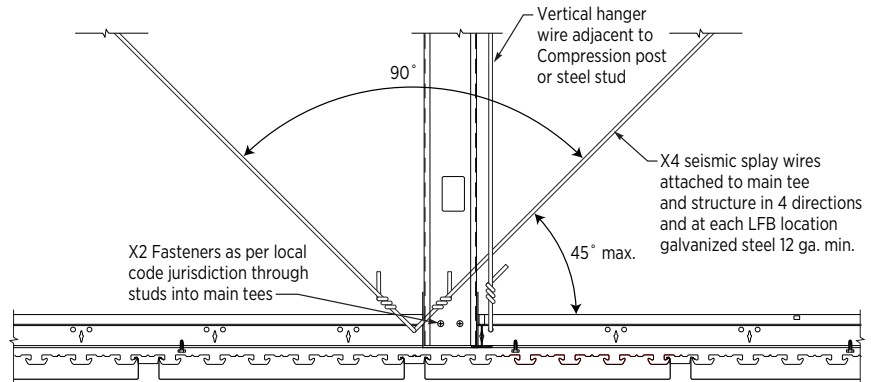

Lateral Force Bracing (LFB) Detail - Along Cross Tee

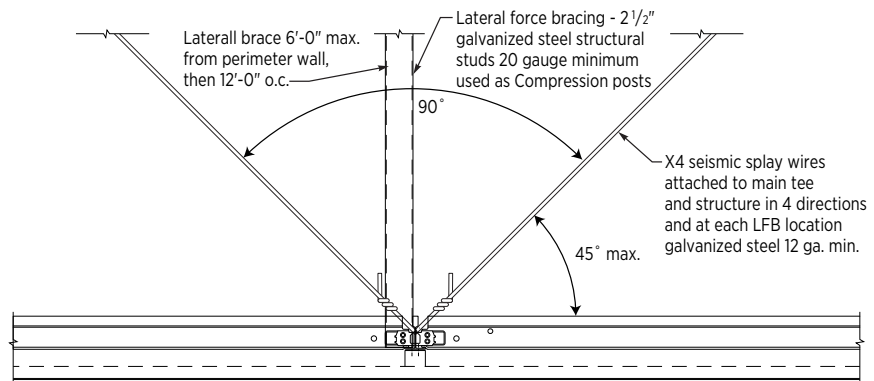

1. Install as per local code jurisdiction
Consult the local code officials or engineer of record having jurisdiction over the project

SEISMIC PERIMETER APPLICATIONS

PLANX™ UNIVERSAL

**NO REVEAL
PERIMETER CONDITIONS¹**

Perimeter Floating Side - Along Main Tee

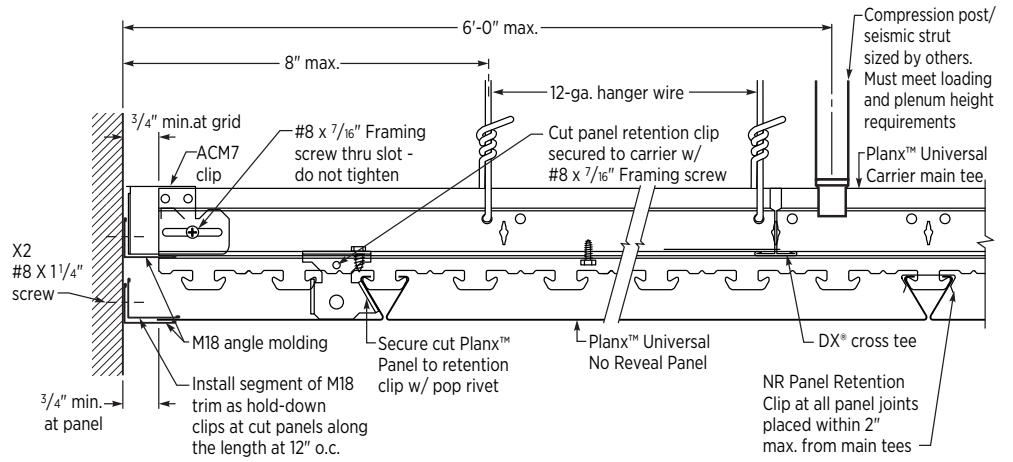

Perimeter Floating Side - Along Cross Tee

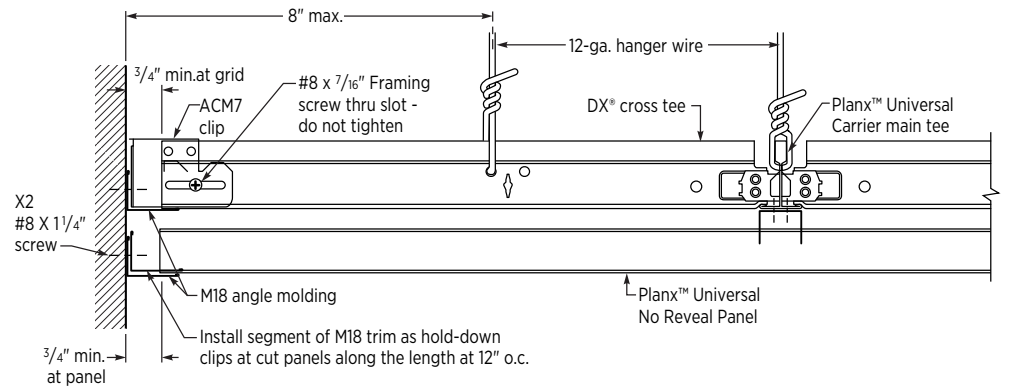

1. Consult the local code officials or engineer of record having jurisdiction over the project.

SEISMIC PERIMETER APPLICATIONS

PLANX™ UNIVERSAL

**NO REVEAL
PERIMETER CONDITIONS¹**

Perimeter Fixed Side - Along Main Tee

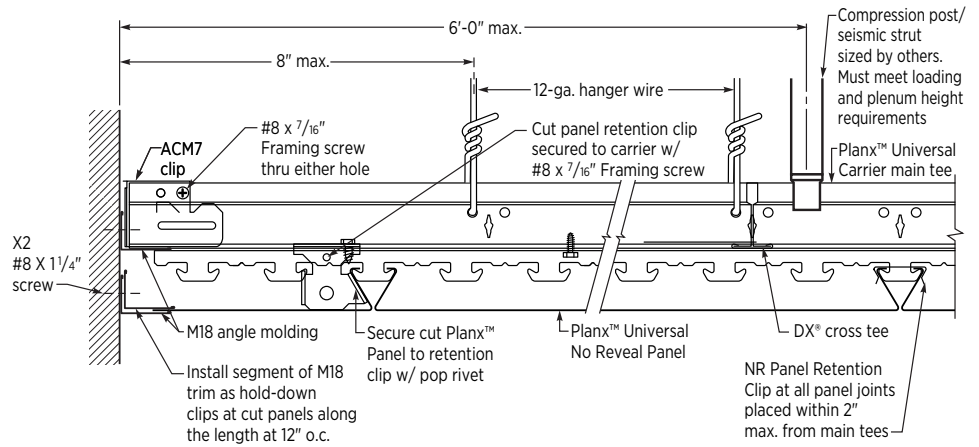

Perimeter Fixed Side - Along Cross Tee

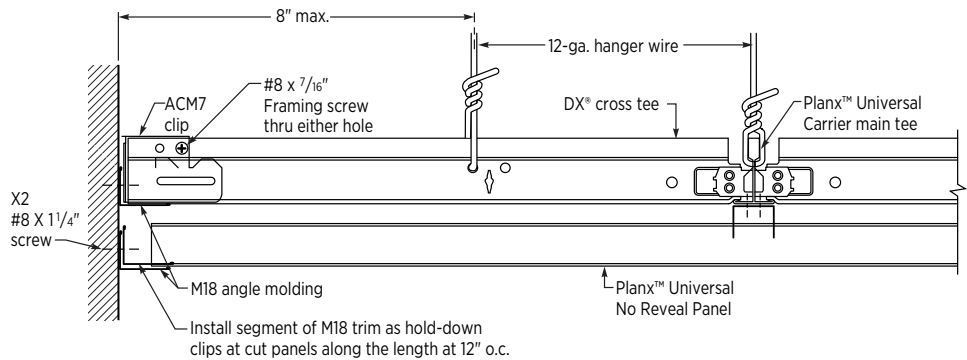

1. Consult the local code officials or engineer of record having jurisdiction over the project.

SEISMIC PERIMETER APPLICATIONS

PLANX™ UNIVERSAL

**NO REVEAL
LATERAL FORCE
BRACING (LFB)¹**

Lateral Force Bracing (LFB) Detail - Along Main Tee

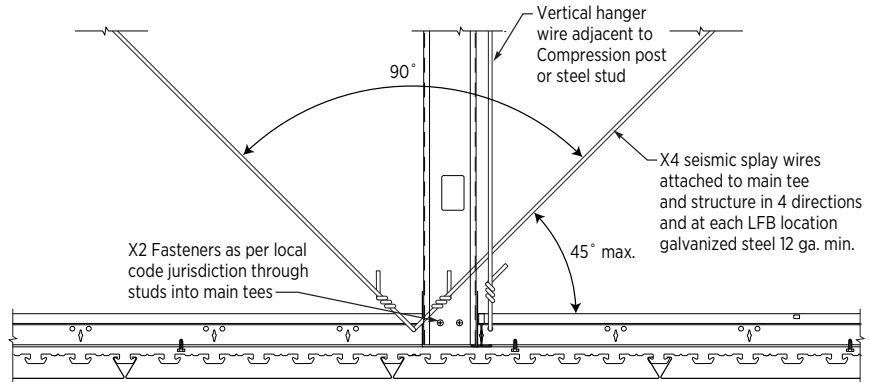

Lateral Force Bracing (LFB) Detail - Along Cross Tee

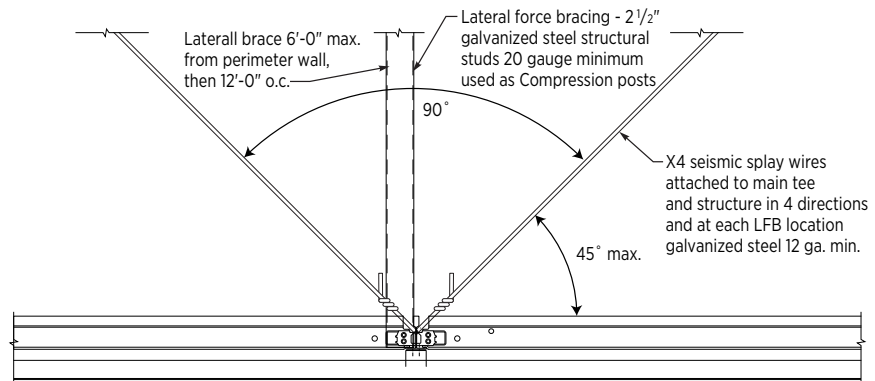

1. Install as per local code jurisdiction
Consult the local code officials or engineer of record having jurisdiction over the project

SEISMIC PERIMETER APPLICATIONS

PLANX™ UNIVERSAL

INTEGRAL REVEAL PERIMETER CONDITIONS¹

Perimeter Floating Side - Along Main Tee

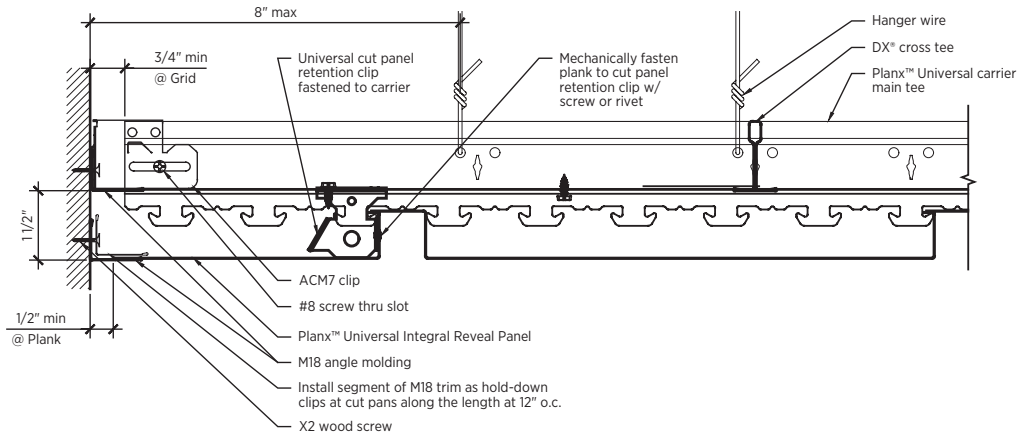

Perimeter Floating Side - Along Cross Tee

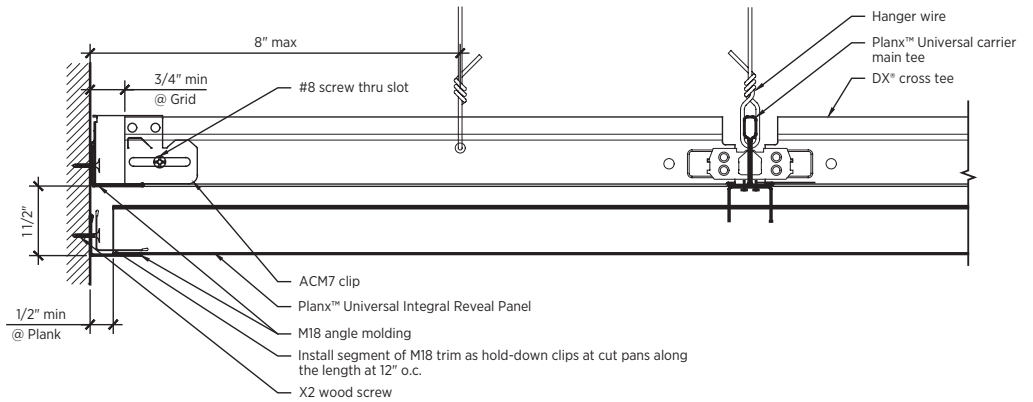

1. Consult the local code officials or engineer of record having jurisdiction over the project.

SEISMIC PERIMETER APPLICATIONS

PLANX™ UNIVERSAL

INTEGRAL REVEAL PERIMETER CONDITIONS¹

Perimeter Fixed Side - Along Main Tee

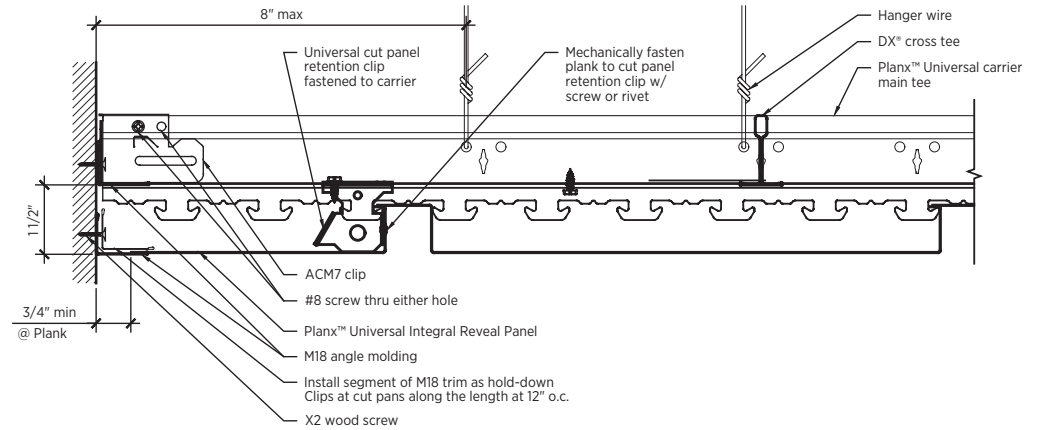

Perimeter Fixed Side - Along Cross Tee

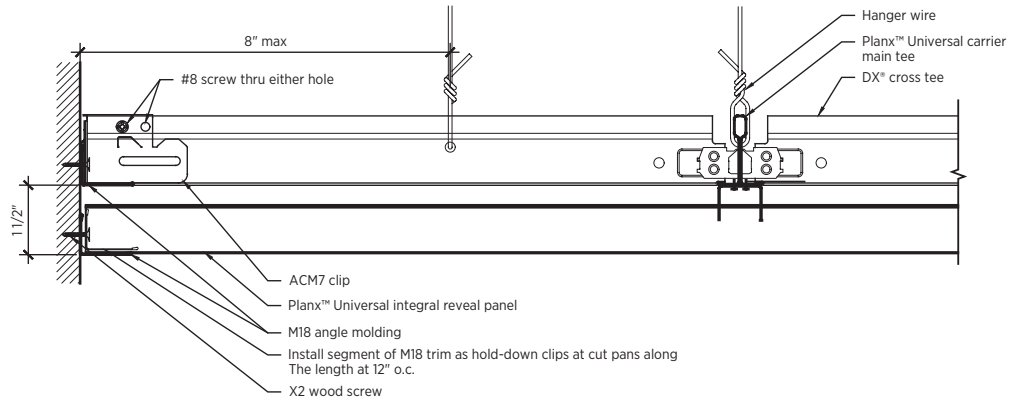

Perimeter Fixed Side - Along Main Tee - ALT (MAC90)

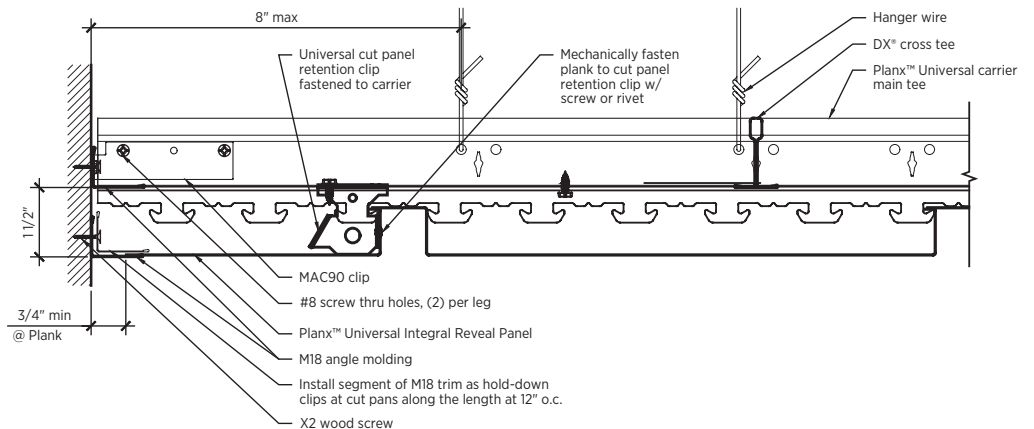

1. Consult the local code officials or engineer of record having jurisdiction over the project.

SEISMIC PERIMETER APPLICATIONS

PLANX™ UNIVERSAL

INTEGRAL REVEAL LATERAL FORCE BRACING (LFB)¹

Lateral Force Bracing (LFB) Detail - Along Main Tee

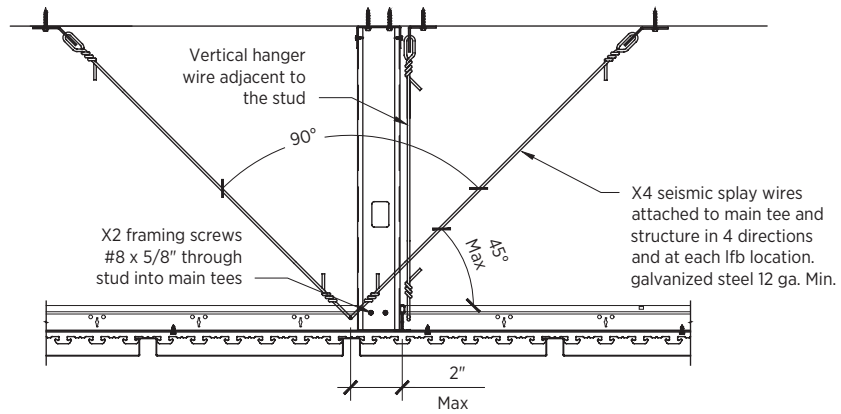

Lateral Force Bracing (LFB) Detail - Along Cross Tee

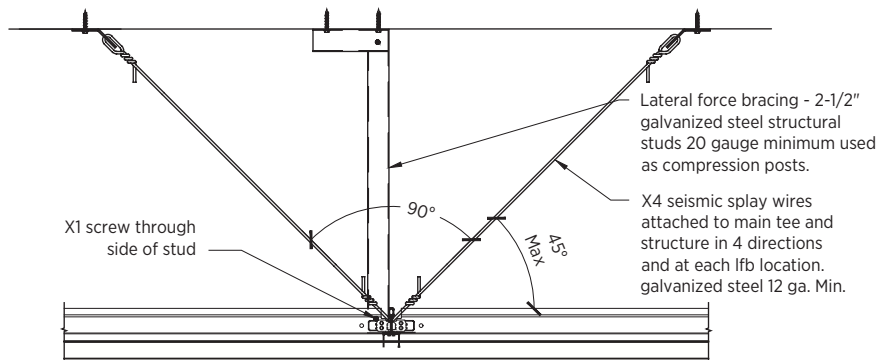

1. Install as per local code jurisdiction
Consult the local code officials or engineer of record having jurisdiction over the project

SEISMIC PERIMETER APPLICATIONS

CELEBRATION™ TORSION SPRING

PERIMETER CONDITIONS¹

Floating

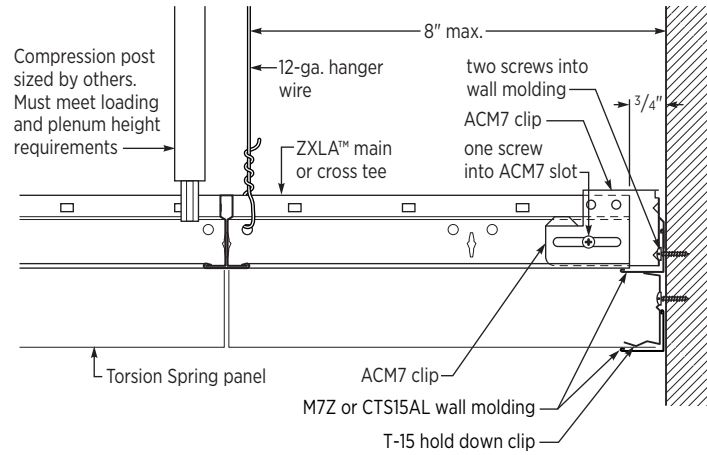

Fixed

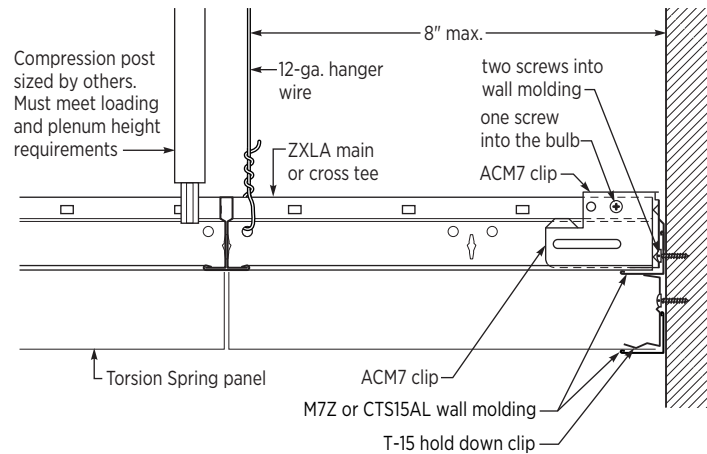

Note: A 3/4 in. gap is shown for typical seismic design categories D-F. Seismic design category C projects shall be constructed to satisfy seismic design category D-F, as illustrated.

1. Other seismic detailing in the field of the system may be required. Typically, the requirements for compression strut under wind loads are more stringent than those for seismic loads; however, there may be some exceptions. Please contact your representative or visit usg.com for more information.

SEISMIC PERIMETER APPLICATIONS

USG SHEETROCK® BRAND LAY-IN PANEL (GLIP) WITH ZXLA™

FLOATING PERIMETER TREATMENT OPTIONS

ACM7 Seismic Clip

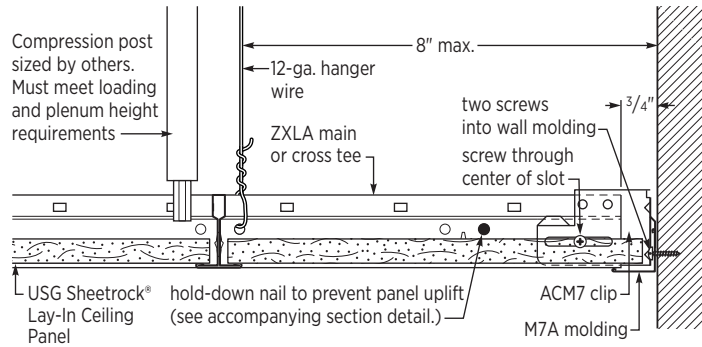

2 in. Wall Molding

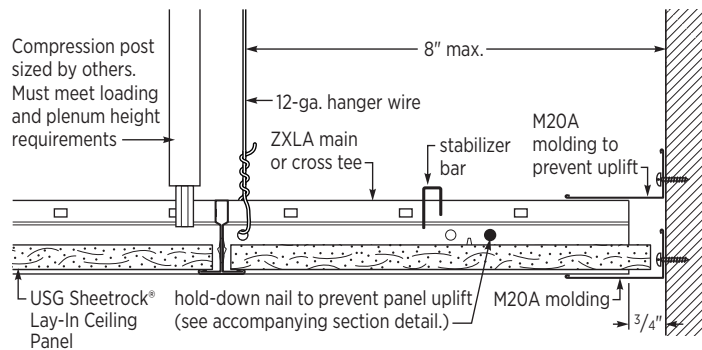

Note: A 3/4 in. gap is shown for typical seismic design categories D-F. Seismic design category C projects shall be constructed to satisfy seismic design category D-F, as illustrated.

HOLD-DOWN NAIL

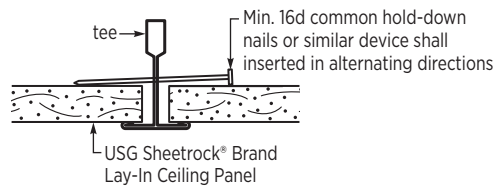

Note: Min. 16d common hold-down nails or similar devices shall be inserted in alternating directions.

1. Other seismic detailing in the field of the system may be required. Typically, the requirements for compression strut under wind loads are more stringent than those for seismic loads; however, there may be some exceptions. Please contact your representative or visit usg.com for more information.

SEISMIC PERIMETER APPLICATIONS

USG SHEETROCK® BRAND LAY-IN PANEL (GLIP) WITH ZXLA™

FIXED PERIMETER TREATMENT OPTIONS

ACM7 Seismic Clip

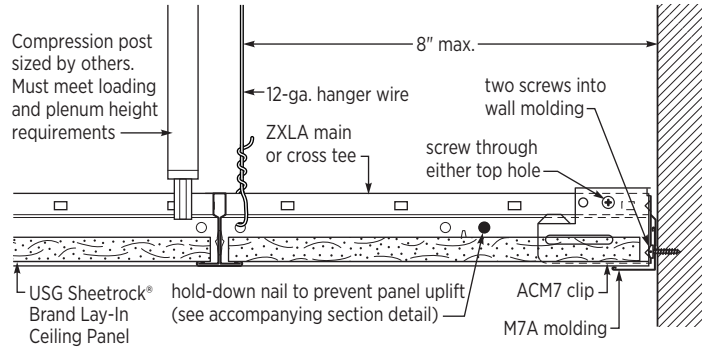

2 in. Wall Molding

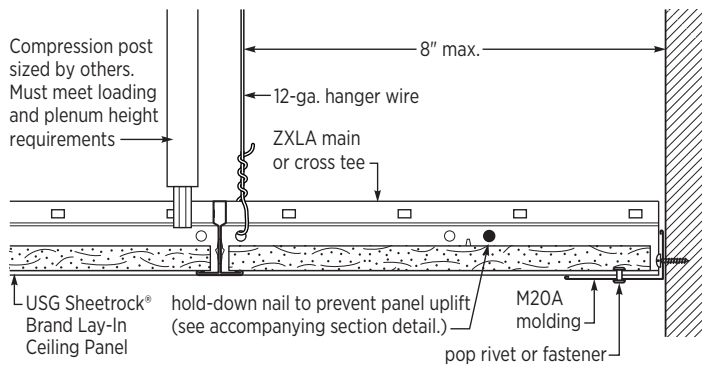

Note: A 3/4 in. gap is shown for typical seismic design categories D-F. Seismic design category C projects shall be constructed to satisfy seismic design category D-F, as illustrated.

HOLD-DOWN NAIL

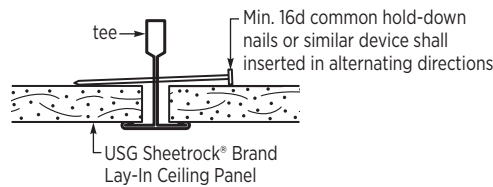

Note: Min. 16d common hold-down nails or similar devices shall be inserted in alternating directions.

1. Other seismic detailing in the field of the system may be required. Typically, the requirements for compression strut under wind loads are more stringent than those for seismic loads; however, there may be some exceptions. Please contact your representative or visit usg.com for more information.

SEISMIC PERIMETER APPLICATIONS

CELEBRATION™ SNAP-IN

PERIMETER CONDITIONS¹

Floating

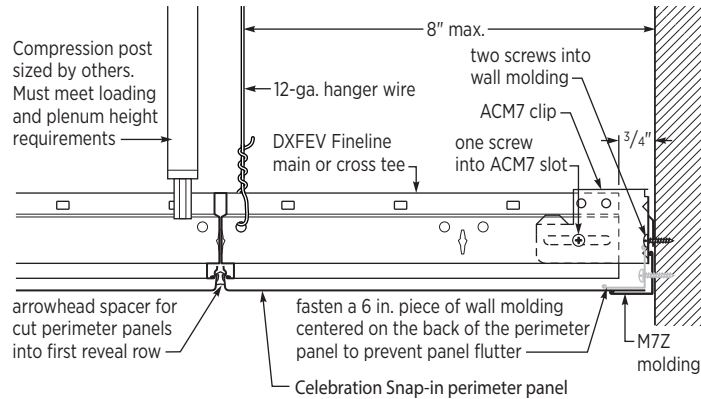

Fixed

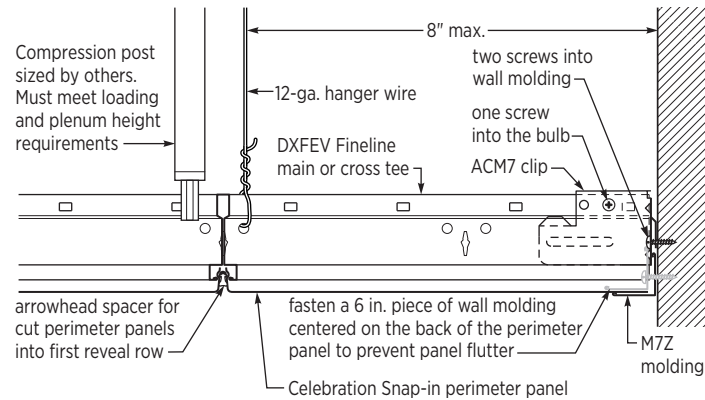

Note: A 3/4 in. gap is shown for typical seismic design categories D-F. Seismic design category C projects shall be constructed to satisfy seismic design category D-F, as illustrated.

1. Other seismic detailing in the field of the system may be required. Typically, the requirements for compression strut under wind loads are more stringent than those for seismic loads; however, there may be some exceptions. Please contact your representative or visit usg.com for more information.

WEBSITES

usg.com

cgcinc.com

usgdesignstudio.com

cgcdesignstudio.com

PRODUCT INFORMATION

DXFEV Data Sheet AC3304. Celebration™ Torsion Spring Exterior Accessories IC642. Exterior Ceilings Installation Guide SC3212. See usg.com for the most up-to-date product information.

INSTALLATION

Must be installed in compliance with ASTM C636, ASTM E580, CISCA, and standard industry practices. Refer to Exterior Ceilings Installation Guide SC3212.

CODE COMPLIANCE

The information presented is correct to the best of our knowledge at the date of issuance. Because codes continue to evolve, check with a local official prior to designing and installing a ceiling system. Other restrictions and exemptions may apply. This is only intended as a quick reference.

PURPOSE

This technical guide is intended as a resource for design professionals, to promote more uniform criteria for plan review and jobsite inspection of projects. This technical guide indicates an acceptable method for achieving compliance with applicable codes and regulations, although other methods proposed by design professionals may be considered and adopted. The renderings and details provided are for illustrative purposes only and are not a substitute for certified architectural and engineering drawings.

ICC EVALUATION SERVICE, INC., REPORT COMPLIANCE

Suspension systems manufactured by USG Interiors, LLC, have been reviewed and are approved by listing in ICC-ES Evaluation Report I222. Evaluation Reports are subject to reexamination, revision and possible cancellation. Please refer to usgdesignstudio.com or usg.com for current reports.

L.A. RESEARCH REPORT COMPLIANCE

Donn® brand suspension systems manufactured by USG Interiors, LLC, have been reviewed and are approved by listing in the following L.A. Research Report number: 25764.

NOTICE

We shall not be liable for incidental and consequential damages, directly or indirectly sustained, nor for any loss caused by application of these goods not in accordance with current printed instructions or for other than the intended use. Our liability is expressly limited to replacement of defective goods. Any claim shall be deemed waived unless made in writing to us within thirty (30) days from date it was or reasonably should have been discovered. Trademarks. Terms and conditions and limits of liabilities apply. For all terms and conditions see usg.com/terms-and-conditions.

SAFETY FIRST!

Follow good safety and industrial hygiene practices during handling and installation of all products and systems. Take necessary precautions and wear appropriate personal protective equipment as needed. Read safety data sheets and related literature on products before specification and/or installation.

Notice

The information in this document is subject to change without notice. CGC Inc. or USG Corp. assumes no responsibility for any errors that may inadvertently appear in this document.

Manufactured by
USG Interiors, LLC
550 West Adams Street
Chicago, IL 60661

SC2561/rev 12-25

© 2025, USG Corporation or its affiliates. All rights reserved. The trademarks BLANCO MAT, CELEBRATION, DONN, DFX, DX, FINELINE, PANZ, PARALINE, PARALOCK, PLANX, SARANTE, SECUROCK, SHEETROCK, TIMBRE, ZXLA, USG, CGC, IT'S YOUR WORLD BUILD IT, THE USG LOGO and related marks are trademarks of USG Interiors, LLC or a related company.

USG  **CGC**
IT'S YOUR WORLD. BUILD IT.®