



MODEL NUMBER:

□ **1662.601 Shower System Kit**

Includes:

- Colony Pressure Balance Valve w/stops 1371SS.240
- Fixed Handshower 1660.505
- Hose 8888.035
- Wall Supply 8888.037
- Standard Slide Bar 1660.225
- In-line Vacuum Breaker 1660.400

GENERAL DESCRIPTION:

Complete personal shower system includes: a Colony pressure balance valve, a wall supply with 1/2" NPT female inlet and 1/2" NPSM male outlet; a 59" (1500mm) shower hose; a "Fixed" personal shower; and a 25" Slide Bar. Valve features a cast brass body, washerless ceramic disc valve cartridge with back-to-back capability and hot limit safety stop. Cycles from off to hot through cold. Exclusive Colony pressure balancing cartridge maintains constant output temperature in response to changes in relative hot and cold supply pressure. One-half inch direct sweat inlets and outlets. With screwdriver stops. Durable metal handle provides easy, certain control for all users. Rough-in plaster guard designed for use as thin-wall mounting adaptor. Fixed handshower with 2.5 gpm/9.5L/min. flow restrictor. Slide bar features an adjustable shower holder which can be set at any height or position along the bar and angle up to 45°.

PRODUCT FEATURES:

VALVE: Cast Brass Valve Body: Durable.

Ceramic Disc Valve Cartridge: Assures a lifetime of drip-free performance.

Colony Pressure Balancing Valve Cartridge: Maintains constant output temperature in response to changes in hot and cold supply pressure.

Back-to-Back Capability: Hot and cold can be reversed quickly and easily.

Adjustable Hot Limit Safety Stop: Limits the amount of hot water allowed to mix with cold. Reduces the risk of accidental scalding.

Integral Plaster Guard and Mounting Plate: Protects valve during installation and serves as a mounting plate for thin-wall installations.

PERSONAL SHOWER:

Lightweight, Ergonomic Design: For a sure grip even with wet, soapy hands.

SLIDE BAR: Simple Height Adjustment: Allows positioning of the personal shower anywhere along the bar.

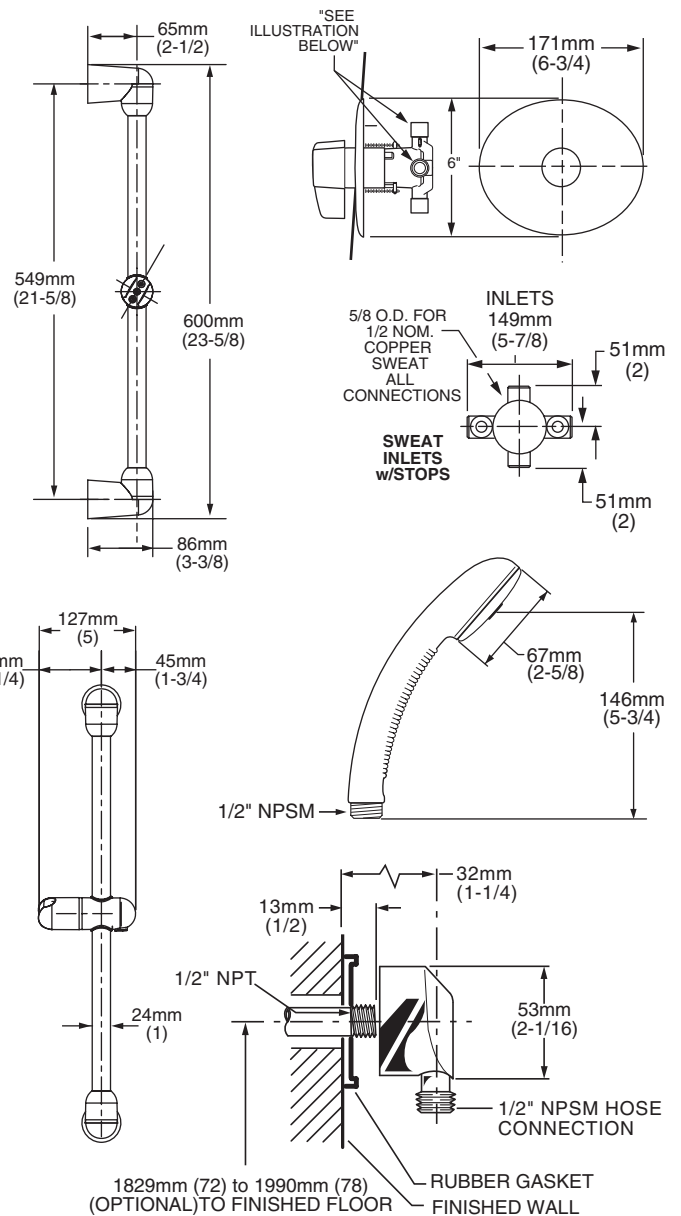

SUGGESTED SPECIFICATION:

Shower system shall feature a wall supply with 1/2" NPT female inlets, 1/2" NPSM male outlet, 59" hose, personal shower and a 25" Standard Slide Bar. Pressure Balance valve shall feature a cast brass body. Shall feature ceramic disc valve cartridge which is capable of back-to-back installation. Shall also feature hot limit safety stop. Fitting shall be American Standard Model # 1662.601.002.

CODES AND STANDARDS

Install as required to comply with local code requirements.

- ASME A112.18.1**
- ASSE 1016**
- ANSI A117.1**

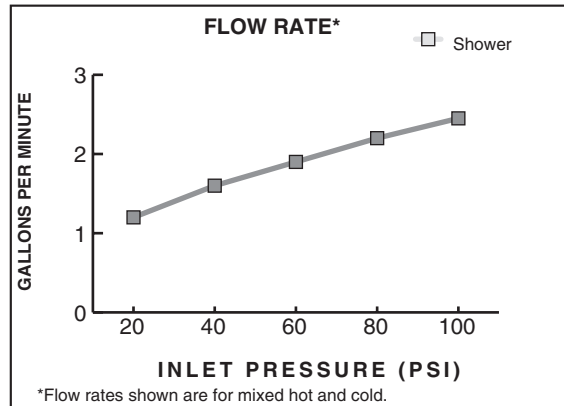

Product Number	Description	Finish
		Polished Chrome
1662.601*	Shower System Kit. Contains pressure balace valve, "Fixed" handshower, hose, wall supply and slide bar.	002

***NOTE:** Mounting brackets are available for corner installations (repair part# 030787-YYY0A).

 Meets the American Disabilities Act Guidelines and **ANSI A117.1** Requirements for the physically challenged.