

INSTALLATION INSTRUCTIONS CARE AND MAINTENANCE

American Standard

Model 2073 FloWise™ Normal Height Elongated High Efficiency Toilet

Thank you for selecting American Standard - the benchmark of fine quality for over 100 years.
To ensure this product is installed properly, please read these instructions carefully before you begin.
(Certain installations may require professional help.) Also be sure your installation conforms to local codes.

⚠ CAUTION: PRODUCT IS FRAGILE. TO AVOID BREAKAGE AND POSSIBLE INJURY HANDLE WITH CARE!
NOTE: Pictures may not exactly define contour of china and components.

NOTE: BACK-TO-BACK INSTALLATION

Depending upon your plumbing and venting conditions, the flow from the FloWise in a back-to-back installation may create a vacuum on the system and draw water from the opposing bowl. The National Standards Plumbing Code prohibits the use of a cross fitting for drainage as throw over is possible. The code does approve a directional "Y" style fitting with proper venting to direct the water downward and away from the other toilet.

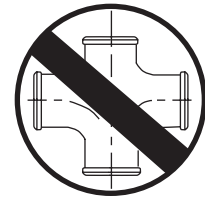
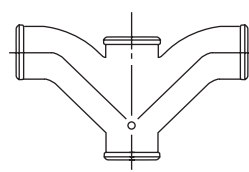

Recommended fitting type for back-to-back installations.

RECOMMENDED TOOLS AND MATERIALS

| | | | |
|--------------|---------------------|----------------------|------------------------------|
| Putty Knife | Regular Screwdriver | Adjustable Wrench | Sealant |
| Hacksaw | Wax Ring/Gasket | Flexible Supply Tube | 1/2" Deep Well Nut Driver or |
| Closet Bolts | Tape Measure | Carpenters Level | Deep Well Socket Wrench |

1 REMOVE OLD TOILET

- Close toilet supply valve and flush tank completely. Towel or sponge remaining water from tank and bowl.
 - Disconnect and remove supply line. NOTE: *If replacing valve, first shut off main water supply!*
 - Remove old mounting hardware, remove toilet and plug floor waste opening to prevent escaping sewer gases.
 - Remove closet bolts from flange and clean away old wax, putty, etc. from base area.
- NOTE: *Mounting surface must be clean and level before new toilet is installed!*

2 ROUGHING-IN DIMENSIONS: Normal Height Elongated Two Piece Toilet

NOTE: DRAWINGS ARE FOR DIMENSIONAL PURPOSES ONLY.
THEY ARE NOT EXACT REPRESENTATIONS.

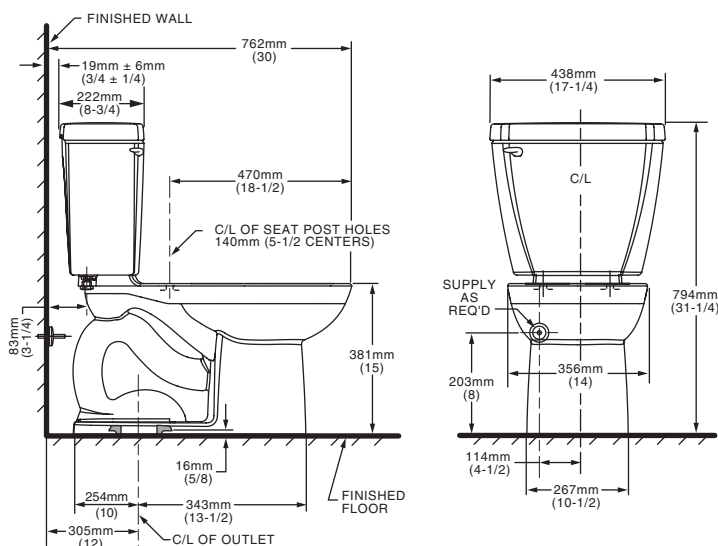

3

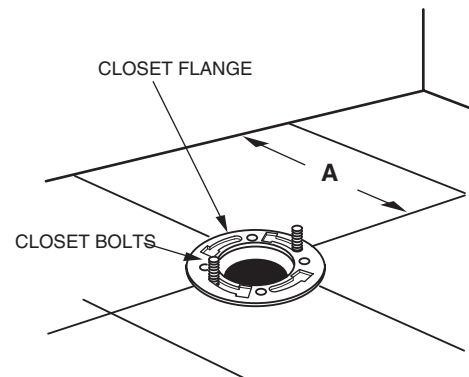

INSTALL CLOSET BOLTS

Install closet bolts in flange channel, turn 90°, and slide into place 6" (152 mm) apart and parallel to wall.

SAVE FOR FUTURE USE

4

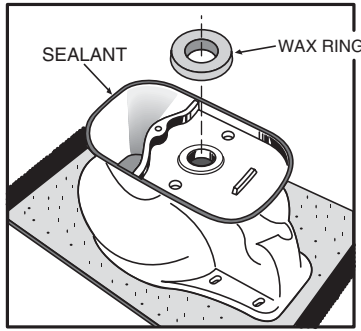

INSTALL WAX SEAL

Invert toilet on floor (cushion to prevent damage), and install wax ring evenly around waste flange, with tapered end of ring facing toilet. Apply a thin bead of sealant around toilet base.

5

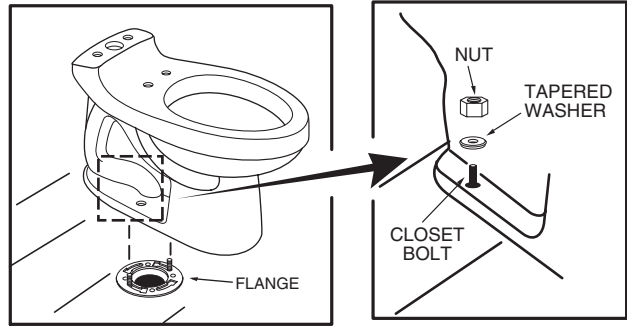

POSITION TOILET ON FLANGE

- a. Unplug floor waste opening and install toilet on closet flange so bolts project through mounting holes.
- b. Loosely install retainer washers and nuts. Side of washers marked "THIS SIDE UP" must face up!

6

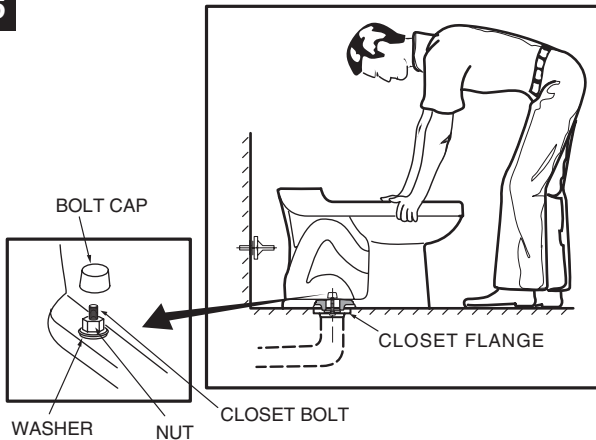

INSTALL TOILET

- a. Position toilet squarely to wall and, with a rocking motion, press bowl down fully on wax ring and flange. Alternately tighten nuts until toilet is firmly seated on floor.
 - ⚠ **CAUTION:** DO NOT OVERTIGHTEN NUTS OR BASE MAY BE DAMAGED!
- b. Install caps on washers. (If necessary, cut bolt height to size before installing caps.)
- c. Smooth off the bead of sealant around base. Remove excess sealant.

7

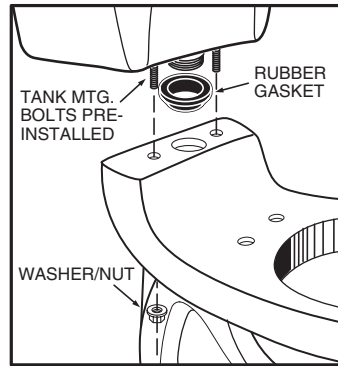

INSTALL TANK

- a. Install large rubber gasket over threaded outlet on bottom of tank and lower tank onto bowl so that tapered end of gasket fits evenly into bowl water inlet opening, and tank mounting bolts go through mounting holes. Secure with metal washer/nuts.
- b. With tank parallel to wall, alternately tighten hex nuts until tank is snugged down evenly against bowl surface.

Recommended tool: Deep socket tool included in tank kit.

- ⚠ **CAUTION:** DO NOT OVERTIGHTEN NUTS MORE THAN REQUIRED FOR A SNUG FIT!
DO NOT SPIN BOLTS WITH SCREWDRIVER

8

INSTALL TOILET SEAT Install toilet seat in accordance with manufacturer's directions.

9a

Before continuing, determine the type of water supply connection you have from the chart below and use the appropriate assembly parts required to properly reconnect the water supply. DO NOT use plumber's putty to seal these fittings.

METAL/COPPER FLARED TUBING

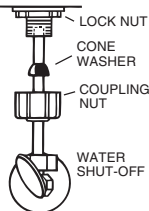

These parts must be used as illustrated to insure water-tight connection. Use of existing coupling nut may result in water leakage. Water supply tube or pipe must extend at least 1/2" inside threaded shank of valve (does not apply to flanged tubing).

METAL FLANGED TUBING

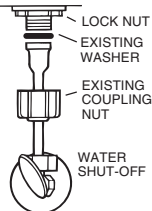

Use existing coupling nut and washer.

METAL SPIRAL TUBING

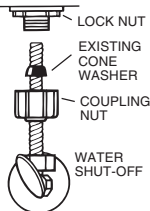

Use existing spiral cone washer. Fluidmaster cone washer may not seal completely on spiral type supply line.

VINYL/BRAIDED CONNECTOR

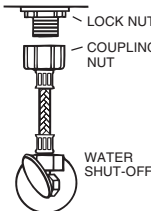

Captive cone washers already included. No additional washers needed.

CAUTION: DO NOT USE CONE WASHER WITH PLASTIC SUPPLY LINE.

CAUTION: Overtightening of LOCK NUT or COUPLING NUT could result in breakage and potential flooding.

9b

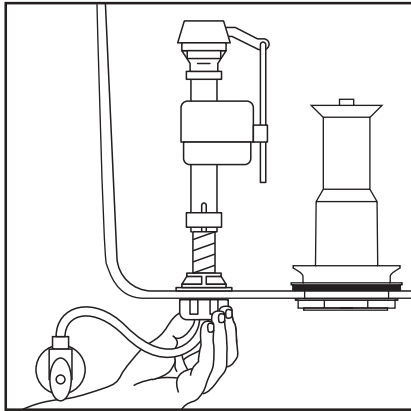

With correct washers in place (see Step 9a), tighten COUPLING NUT 1/4 turn beyond hand tight.

DO NOT OVERTIGHTEN.

10

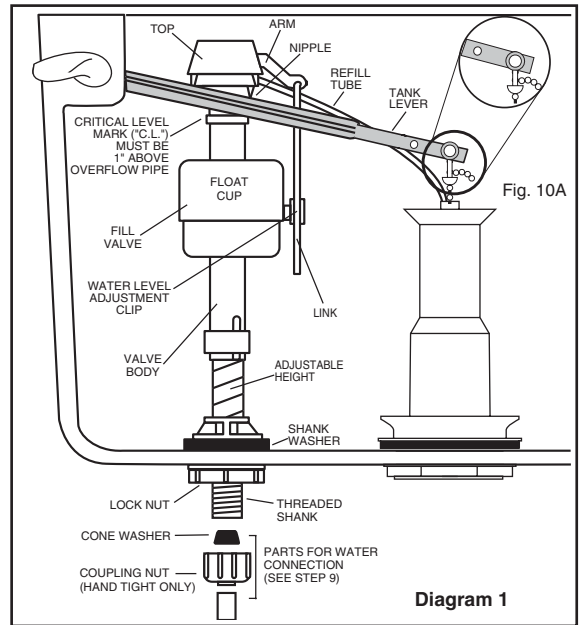

Diagram 1

ADJUSTMENTS

- a. Adjust water level. Water level should be adjusted to level indicated in tank by adjusting float cup. See Step 11 for water level adjustment method.

IMPORTANT:

- b. If bowl fails to siphon, an adjustment may be required with the lift chain. Simply remove the bead chain from the retainment clip (see Fig. 10A) and take up slack on the chain, and reinsert on lift rod. Make sure the chain is not too tight. Make sure the chain is not too tight. Proper adjustment will allow the tower to lift and auto release with the handle held down.

11

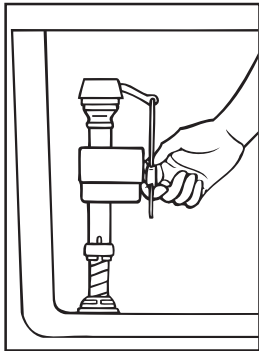

Turn on water supply. Adjust water to water level specified in the tank by squeezing water level adjustment clip and moving FLOAT CUP up or down along stainless steel link.

12

CARE AND CLEANING

When cleaning your toilet, wash it with mild, soapy water, rinse thoroughly with clear water and dry with a soft cloth.

! WARNING: Do not use in-tank cleaners. These products can seriously damage fittings in the tank. This damage can cause leakage and property damage.

American Standard shall not be responsible or liable for any damage caused by the use of in-tank cleaners.

13

TROUBLE SHOOTING FLUSH VALVE: SEAL REPLACEMENT:

1. Disconnect Chain.
2. Lift float up and remove flush valve seal by pulling seal out of groove and sliding up over float.
3. Reverse procedure to install new seal.

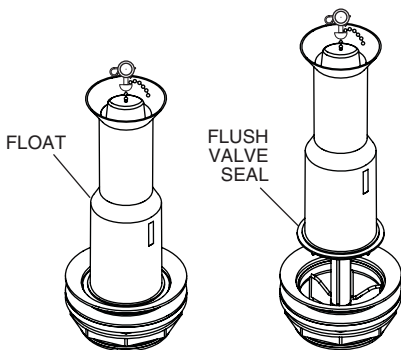

NOTE: DO NOT ADD ANY FOREIGN MATERIALS TO THE SEALING SURFACE.

13a

REFILL TUBE REPLACEMENT:

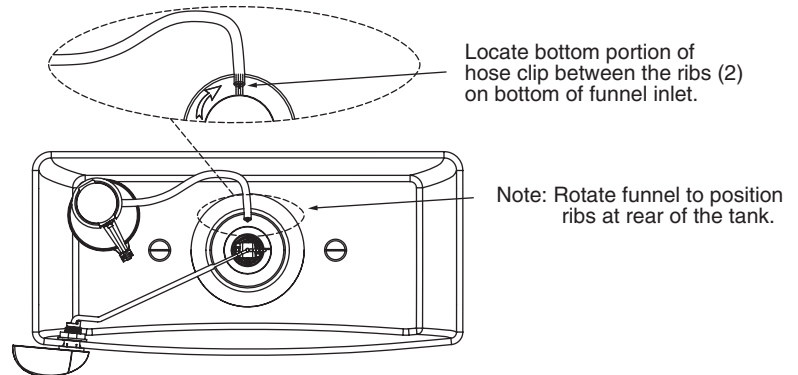

Locate bottom portion of hose clip between the ribs (2) on bottom of funnel inlet.

Note: Rotate funnel to position ribs at rear of the tank.

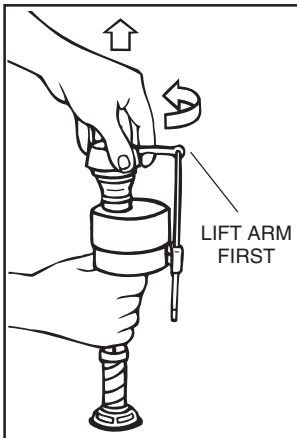

IMPORTANT: Always clear sand and rust from system. Make sure water supply is off. Remove valve TOP by lifting arm and rotating top and arm 1/8 turn counterclockwise, pressing down slightly on cap.

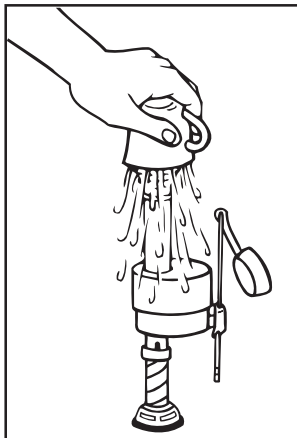

While holding a container over the uncapped VALVE to prevent splashing, turn water supply on and off a few times. Leave water supply off.

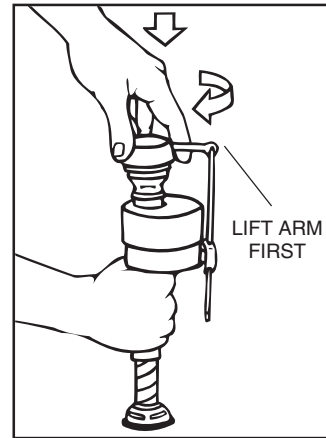

Replace TOP by engaging lugs and rotating 1/8 turn clockwise. **MAKE CERTAIN TIP IS TURNED TO THE LOCKED POSITION. VALVE MAY NOT TURN ON IF TOP IS NOT FULLY TURNED TO THE LOCKED POSITION.**

TROUBLESHOOTING FILL VALVE

IF FILL VALVE SHUTS OFF BUT CONTINUES TO LEAK SLOWLY, repeat Step 14.

IF FILL VALVE TURNS OFF AND ON DURING PERIODS OF NON-USE, it is a signal you are wasting water because:

- The end of the refill tube is inserted into overflow pipe, below water level in tank. Attach refill tube to overflow pipe using "S" clip provided.
- The flush valve is leaking because it's worn, dirty or misaligned (replace seal or flush valve).

IF FILL VALVE WON'T TURN ON OR SHUT OFF or REFILL OF TANK WATER IS SLOW after valve has been in use for some time, Fluidmaster Model 242 Replacement Seal may be needed.

For troubleshooting information please contact:

Fluidmaster Inc

30800 Rancho Viejo Road
San Juan Capistrano, CA 92675
(949) 728-2000 (800) 631-2011
www.fluidmaster.com

© 2001 Fluidmaster, Inc.

© Registered trademark of Fluidmaster, Inc.

Manufacturer's First Year Fill Valve Warranty:

GUARANTEE: This Fluidmaster product is guaranteed to be free from defective materials and workmanship for a period of one year. Units returned to Fluidmaster will be replaced without charge.

Always use quality Fluidmaster repair parts when maintaining your Fluidmaster products. Fluidmaster shall not be responsible or liable for any damages caused by products used with Fluidmaster valves that were not manufactured by Fluidmaster, Inc.

See next page for FloWise™ Ten-Year Worry-Free™ Limited Warranty.

REPAIR PARTS LIST

Repair parts are determined by toilet tank number which can be found marked inside tank.

NOTE: "XXX" represents color or trim finish options. Specify when ordering.

| PART NO. | DESCRIPTION |
|------------------|--|
| 738611-XXX0A | TRIP LEVER |
| 034783-XXX0A | BOLT CAP KIT (INCL 2 COVERS & WASHERS) |
| 738565-409-0070A | FLUIDMASTER 400A VALVE |
| 738651-0070A | FLUSH VALVE SEAL |
| 3175.002-0070A | FLUSH VALVE ASSEMBLY |
| 738930-0070A | BEAD CHAIN WITH CLEVIS PIN |
| 738657-0070A | SILICON REFILL TUBE |
| 738756-0070A | TANK TO BOWL COUPLING KIT #241 |
| 735119-400.XXX | TANK COVER |
| 072989-0070A | CLIP FOR REFILL TUBE |

TROUBLESHOOTING GUIDE

| PROBLEM | POSSIBLE CAUSE | CORRECTIVE ACTION |
|--------------------------|---|--|
| Does not flush | a. Water supply valve closed. | a. Open valve and allow water to fill tank. |
| | b. Supply line blocked. | b. Shut off water supply, disconnect supply line and inspect all gaskets and washers. Reassemble. Also, see Fluidmaster maintenance. (see Step 14) |
| | c. Flush valve chain too loose or disconnected. | c. Readjust chain length as required. |
| | d. Sand or debris lodged in water control. | d. Shut off water supply. Remove cap and clean as per Step 14. |
| Poor or sluggish flush | a. Bowl water level too low. | a. Check that refill tube is connected to water control and inserted into tank overflow without being kinked or damaged. (see Step 13a) |
| | b. Supply valve partly closed. | b. Open supply valve fully. Be sure that proper supply tube size is used. |
| | c. Partially clogged trapway and/or drain pipe and/or vent. | c. Remove obstruction. Consult a plumber if necessary. |
| | d. Supply pressure too low. | d. Normal supply pressure must be at least 20 psi. |
| | e. Flush valve chain too tight, pull rod not engaging. | e. Readjust chain length as needed. Review Step 10. |
| Toilet leaks | a. Poor supply line connection. | a. Review Step 9 of installation procedure. |
| | b. Poor bowl to tank/floor connection. | b. Review Step 4 through 7 of installation procedure. |
| Toilet does not shut off | a. Flush valve seal leaking or deformed. | a. Clean debris from seal surface. Replace flush valve seal as needed. (see Step 13) |
| | b. Sand or debris lodged in water control. | b. Shut off water supply. Remove cap and clean as per Step 14. |

FloWise™ HET TEN-YEAR WORRY-FREE™ LIMITED WARRANTY

For this warranty to become effective, the accompanying warranty registration card and proof of purchase must be completed and returned to the address on the warranty registration card within 30 days of purchase.

If inspection of this American Standard plumbing product, inclusive of china and all mechanical components, within ten years after its initial purchase, confirms that it is defective in materials or workmanship, American Standard will repair or, at its option, exchange the product for a similar model.

This warranty **does not apply** to local building code compliance. Since local building codes vary considerably, the purchaser of this product should check with a local building or plumbing contractor to insure local code compliance before installation.

This warranty **shall be void** if the product has been moved from its initial place of installation; if it has been subjected to faulty maintenance, abuse, misuse, accident or other damage; if it was not installed in accordance with American Standard's instructions; or if it has been modified in a manner inconsistent with the product as shipped by American Standard.

This warranty **DOES NOT COVER** any damage caused by the use of in-tank cleaners.

American Standard's option to repair or exchange the product under this warranty does not cover any labor or other costs of removal or installation, **nor shall American Standard be responsible for any other incidental or consequential damages attributable to a product defect or to the repair or exchange of a defective product, all of which are expressly excluded from this warranty.** (Some states or provinces do not allow the exclusion or limitation of implied warranties, so this exclusion may not apply to you.)

This warranty gives you specific legal rights. You may have other statutory rights that vary from state to state or from province to province, in which case this warranty does not affect such statutory rights.

For service under this warranty, it is suggested that a claim be made through the contractor or dealer from or through whom the product was purchased, or that a service request (including a description of the product model and of the defect) be sent to the following address:

In the United States:

American Standard Inc.
P.O. Box 6820

Piscataway, New Jersey 08855
Attention: Director of Consumer Affairs

For residents of the United States, warranty information may also be obtained by calling the following toll free number: (800) 442-1902
www.americanstandard-us.com

In Canada:

American Standard
2480 Stanfield Rd.
Mississauga, Ontario
Canada L4Y 1S2
Toll Free: (800) 387-0369
www.americanstandard.ca

In Mexico:

Customer Service Manager
Ideal Standard, S.A. de C.V.
Via Morelos #330
Col. Santa Clara
Ecatepec 55540 Edo. Mexico
www.americanstandard.com.mx