

SLOAN®

INSTALLATION INSTRUCTIONS BATTERY POWERED SENSOR OPERATED LAVATORY FAUCETS

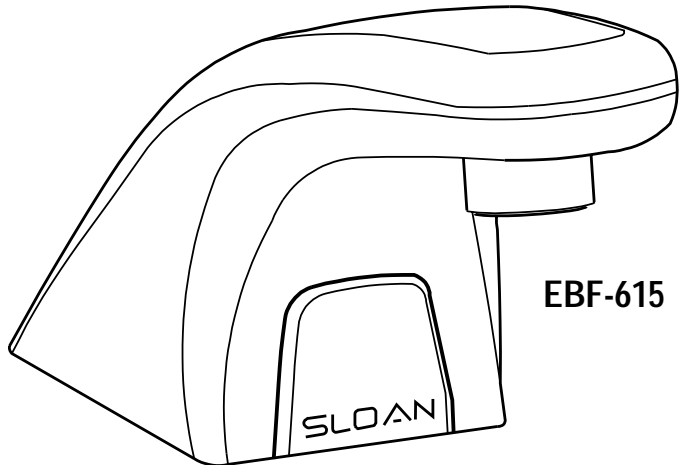

EBF-615
EBF-650
Battery Powered
Sensor Operated
Lavatory Faucets

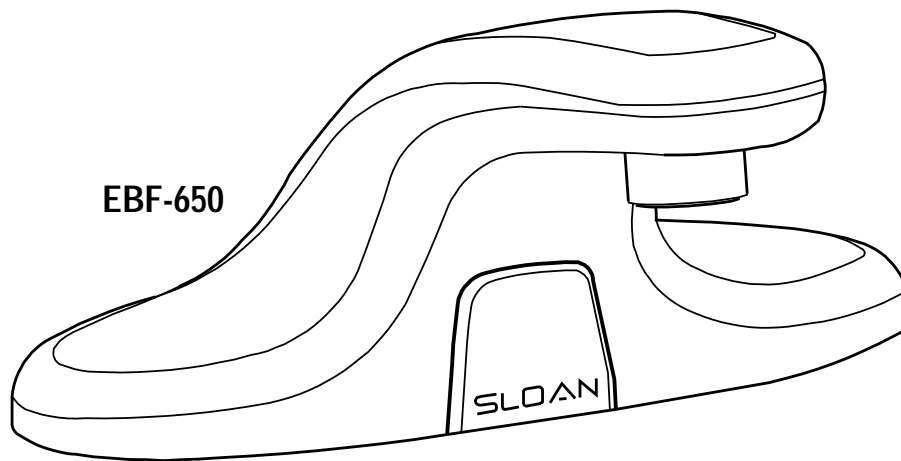

Includes Instructions for
Installation of Optional
Back Checks

Made in the U.S.A.

ANSI/ASME A112.18.1M



Installation of the Sloan OPTIMA *Plus* EBF-615 or EBF-650 Battery Powered, Sensor Operated Faucet makes wash-up totally "hands-free" providing the ultimate in sanitary protection and automatic operation. The OPTIMA *Plus* faucet uses infrared technology to sense the user's presence and turn on a water supply that has been pre-mixed to the desired water temperature. When the user's hands are removed from the invisible beam of light, the water supply automatically turns off. In addition, the faucet is powered by four "C" cell batteries which eliminates the need to run any electrical lines to the system.

The Sloan EBF-615 or EBF-650 battery powered, sensor operated faucet comes

complete with an integral faucet and sensor assembly, control module, alkaline batteries (Size C), and all mounting hardware. Back checks and a grid strainer are also available as optional equipment. The installer should supply 3/8 inch copper supply tube or flexible hose connections.

The following instructions serve as a guide when installing the Sloan EBF-615 or EBF-650 faucet. As always, good safety practices and care are recommended when installing your new faucet. If further assistance is required, contact your nearest Sloan Representative office or the Sloan Installation Engineering Department at 1-888-SLOAN-14.

LIMITED WARRANTY

Sloan Valve Company warrants its EBF-615 and EBF-650 Faucets to be made of first class materials, free from defects of material or workmanship under normal use and to perform the service for which they are intended in a thoroughly reliable and efficient manner when properly installed and serviced, for a period of three years (1 year for decorative finishes) from date of purchase. During this period, Sloan Valve Company will, at its option, repair or replace any part or parts which prove to be thus defective if returned to Sloan Valve Company, at customer's cost, and this shall be the sole remedy available under this warranty. No claims will be allowed for labor, transportation or other incidental costs. This warranty extends only to persons or organizations who purchase Sloan Valve Company's products directly from Sloan Valve Company for purpose of resale. This warranty does not cover the life of the batteries.

THERE ARE NO WARRANTIES WHICH EXTEND BEYOND THE DESCRIPTION ON THE FACE HEREOF. IN NO EVENT IS SLOAN VALVE COMPANY RESPONSIBLE FOR ANY CONSEQUENTIAL DAMAGES OF ANY MEASURE WHATSOEVER.

EBF-615 FAUCET ROUGH-IN — Figure A

EBF-615 FAUCET WITH DUAL LINE WATER SUPPLY

MODEL EBF-615-A-2 — 0.5 gpm (1.9 Lpm) Max.

MODEL EBF-615-B-2 — 2.2 gpm (8.3 Lpm) Max.

MODEL EBF-615-C-2 — 2.2 gpm (8.3 Lpm) Max. Laminar Flow

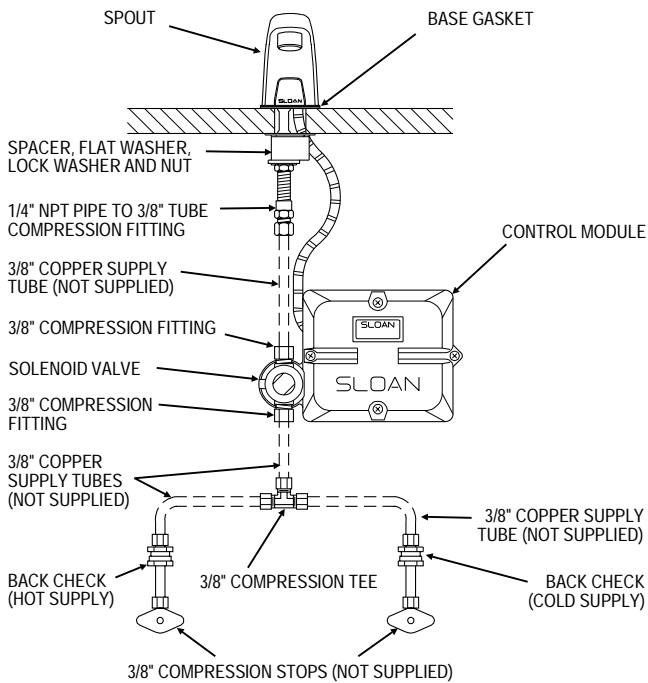

EBF-615 FAUCET WITH SINGLE LINE WATER SUPPLY

MODEL EBF-615-A — 0.5 gpm (1.9 Lpm) Max.

MODEL EBF-615-B — 2.2 gpm (8.3 Lpm) Max.

MODEL EBF-615-C — 2.2 gpm (8.3 Lpm) Max. Laminar Flow

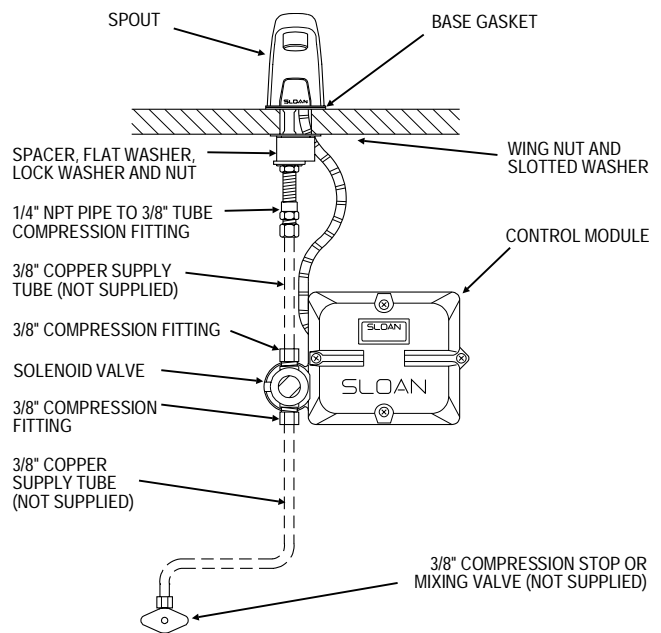

EBF-650 FAUCET ROUGH-IN — Figure B

EBF-650 FAUCET WITH DUAL LINE WATER SUPPLY

MODEL EBF-650-A-2 — 0.5 gpm (1.9 Lpm) Max.

MODEL EBF-650-B-2 — 2.2 gpm (8.3 Lpm) Max.

MODEL EBF-650-C-2 — 2.2 gpm (8.3 Lpm) Max. Laminar Flow

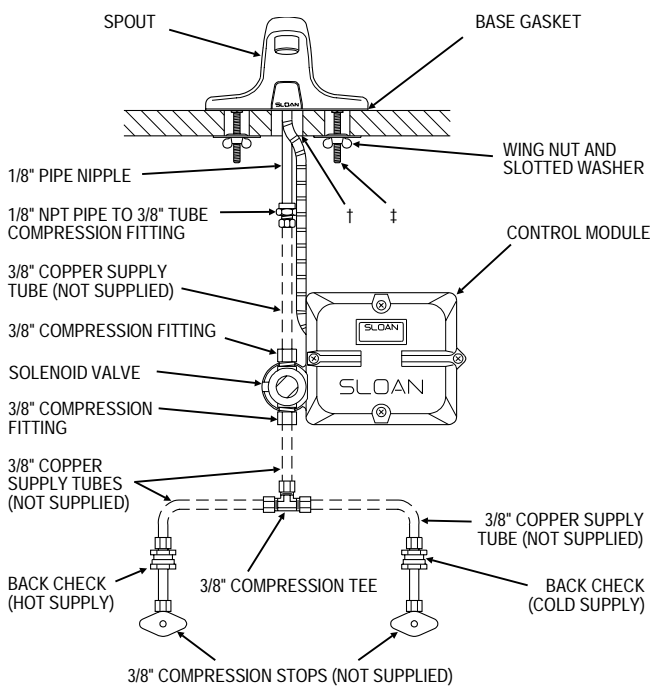

EBF-650 FAUCET WITH SINGLE LINE WATER SUPPLY

MODEL EBF-650-A — 0.5 gpm (1.9 Lpm) Max.

MODEL EBF-650-B — 2.2 gpm (8.3 Lpm) Max.

MODEL EBF-650-C — 2.2 gpm (8.3 Lpm) Max. Laminar Flow

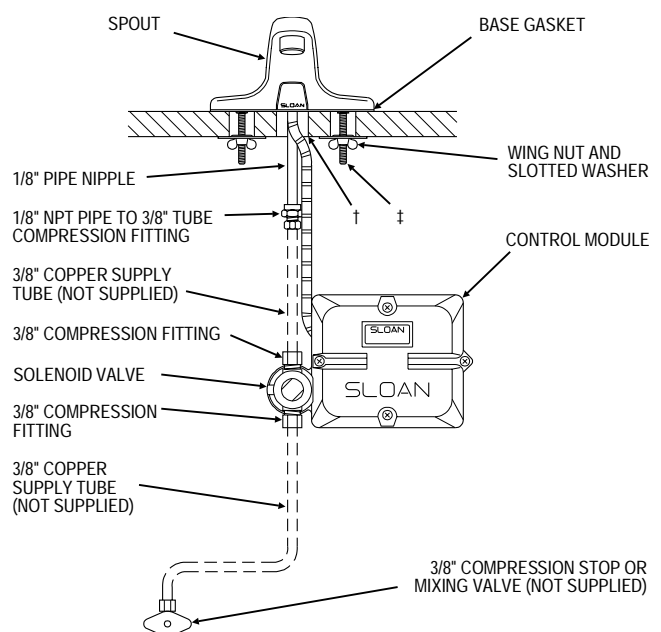

† 1" (25 mm) minimum diameter hole required to mount faucet shank on deck.

‡ 3/8" (10 mm) minimum diameter clearance for mounting studs.

FAUCET SIDE VIEW — Figure C

EBF-615 FAUCET WITH BOTH DUAL AND SINGLE LINE WATER SUPPLIES

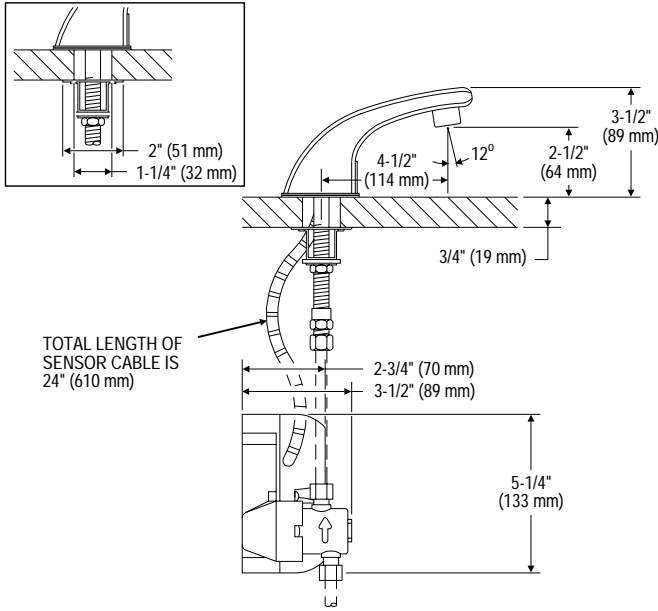

EBF-650 FAUCET WITH BOTH DUAL AND SINGLE LINE WATER SUPPLIES

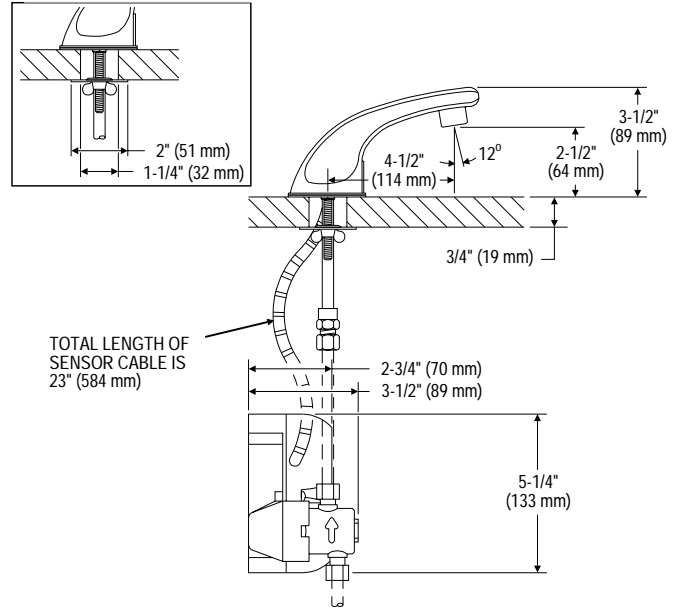

PRIOR TO INSTALLATION

Prior to installing the Sloan EBF-615 or EBF-650 faucet, install the items listed below. Also, refer to Figures A, B and C.

- Lavatory/sink
- Drain line
- Hot and cold water supply lines or tempered water supply line

IMPORTANT:

- ALL PLUMBING IS TO BE INSTALLED IN ACCORDANCE WITH APPLICABLE CODES AND REGULATIONS.
- FLUSH ALL WATER LINES PRIOR TO MAKING CONNECTIONS.

Mixing Valve

When installation includes Sloan's MIX-25-A or MIX-30-A Mixing Valve, these instructions AND those included with the Mixing Valve MUST be followed.

TOOLS REQUIRED FOR INSTALLATION

- Open end wrenches for the following hex sizes (In.): 1/2, 9/16, 5/8, 11/16, 1
- Basin wrench
- Phillips head screwdriver, #2
- Hammer (if installing plastic or hollow wall anchors to mount control module)
- Pliers
- 1/4" drill bit (if installing plastic wall anchors to mount control module)
- 5/16" drill bit (if installing hollow wall anchors to mount control module)
- 3/8" drill bit (if installing toggle nut anchors to mount control module)

INSTALLATION OF EBF-615 OR EBF-650 FAUCET

DO NOT INSTALL THE BATTERIES UNTIL THE FAUCET IS COMPLETELY INSTALLED. If the batteries are installed before the sensor cable has been connected to the control module, the faucet will not properly set the sensing range for the sink on which it has been installed.

The Sloan EBF-615 and EBF-650 battery powered, sensor operated faucets can be supplied with two back checks. When connecting the faucet to a hot and cold water supply, two back checks are required as shown in Figure 1. Water temperature can be controlled by adjusting the supply stops. When connecting the faucet to a single line water supply or a pre-tempered water supply, a back check is not required.

Step 1 — Install Back Checks (Option) (Figure 1)

The Sloan Back Check is designed for installation on a 3/8" Supply Stop. If an existing Stop is used, the Stop may require replacement or additional fittings not supplied by Sloan for connection of the Back Checks to the hot and cold water supply lines. Supply Stops should be furnished by the installer.

After flushing the water supply lines through the Stops, use a compression nut and compression sleeve to connect inlet end of Back Check to the Supply Stop. Tighten Securely.

Note: Failure to install the Back Checks can result in a cross flow connection when the faucet is in the off position and the supply stops are open. If the pressures of the hot water supply and cold water supply are different, hot water can migrate into the cold water supply or cold water can migrate into the hot water supply. Most plumbing codes require that the Back Checks be used to prevent this occurrence.

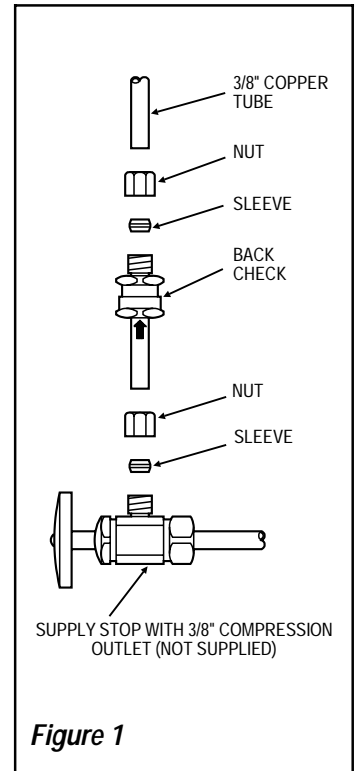

Figure 1

IMPORTANT NOTES

DO NOT INSTALL THE BATTERIES UNTIL THE FAUCET IS COMPLETELY INSTALLED. If the batteries are installed before the sensor cable has been connected to the control module, the faucet will not properly set the sensing range for the sink on which it has been installed.

Step 2 — Install Faucet

Use Step 2A for EBF-615 Faucet Model and Step 2B for EBF-650 Faucet Model.

Step 2A — Install EBF-615 Faucet (Figure 2A)

Note: Sloan Valve Company recommends that this faucet be installed with our trim plate. Our trim plate includes an anti-rotation feature to prevent rotary motion of this single-hole pedestal-style faucet.

Slide Faucet Base Gasket over Faucet Shank and Sensor Cable. Install optional Trim Plate next followed by the Trim Plate Gasket. Holding Faucet Base Gasket and optional Trim Plate assembly in place, insert Sensor Cable and Faucet Shank through the 1" (25 mm) center hole in deck or lavatory. Use plumber's putty to secure optional Trim Plate. Thread Sensor Cable through side of Mounting Spacer, and then secure Faucet to deck or lavatory using the mounting Washer, Lock Washer and Nut. Apply thread sealant or Teflon tape to threads at end of Faucet Shank. Install 3/8" Compression Fitting on end of Faucet Shank.

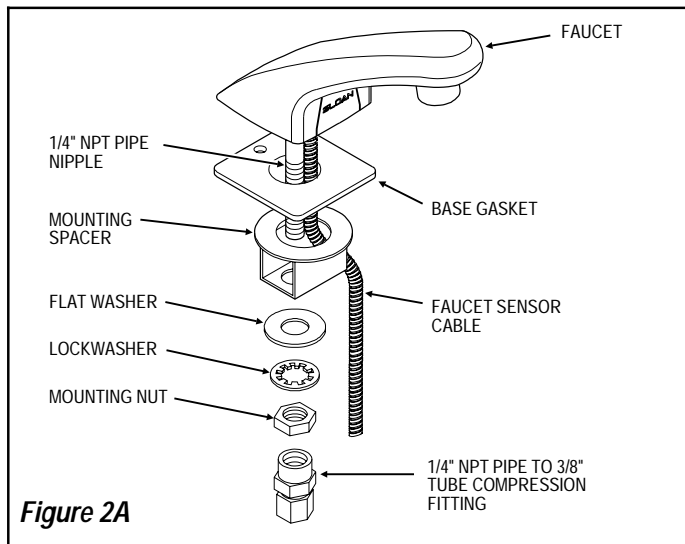

Step 2B — Install EBF-650 Faucet (Figure 2B)

Note: Refer to the Installation Instructions included with the ETF-578-A Trim Plate for additional information about using an 8" Trim Plate with an EBF-650 faucet.

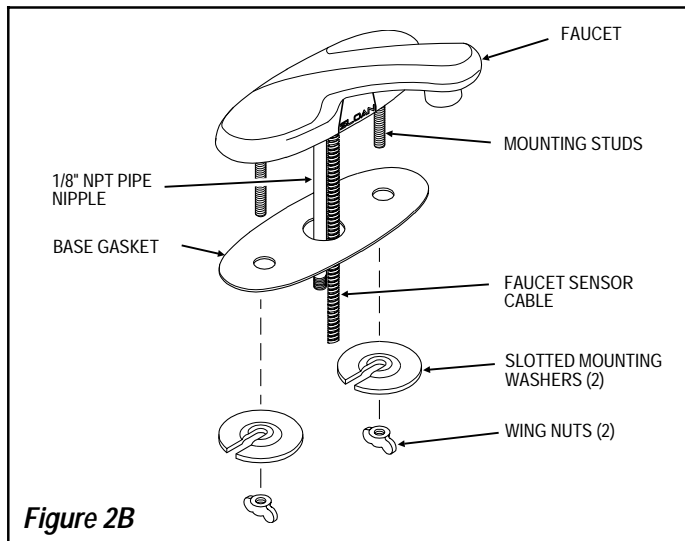

Slide Faucet Base Gasket onto Faucet as shown in Figure 2B.

Insert Faucet Sensor Cable, Pipe Nipple, and Mounting Studs through the 4 inch (102 mm) spread deck holes. Secure Faucet to deck using Slotted Mounting Washers and Wing Nuts supplied.

Step 3 — Mount Control Module to Wall (Figures A, B, and 3)

Important: DO NOT install Control Module upside down. The control module may be oriented so that it faces sideways (vertically); however, optimum performance is obtained when Control Module is horizontal with the Sloan logo on the cover facing up as shown in Figures A and B.

Install the Control Module in an appropriate location according to Figure A or B. All four (4) Cover Screws must be accessible from the chosen mounting position. After installation, the Cable from Spout to Control Module should have some slack.

Remove Control Module Cover from Control Module Base. Use the Control Module Base as a template to mark locations on wall for Mounting Fasteners. Determine the appropriate Mounting Fastener for the particular wall type (three different fastener types are included; see parts list). Drill four (4) appropriately sized holes.

- For plastic wall anchor — 1/4" (6 mm) holes
- For hollow wall anchor — 5/16" (8 mm) holes
- For toggle nut anchor — 3/8" (10 mm) holes

Attach Control Module Base to wall using the appropriate fastener.

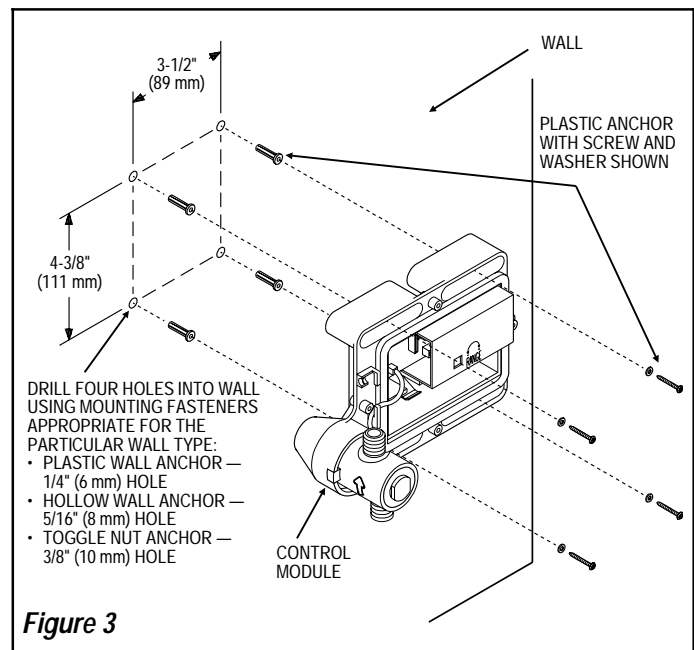

Step 4 — Connect Sensor Cable to Control Module (Figure 4)

Remove Circuit Board Cover from Control Module.

Route Sensor Cable from Spout to the Control Module, usually located under faucet with sufficient slack in Sensor Cable. Insert Locking Connector from Faucet Spout into mating Receptacle on Connector Board of Control Module.

Insert the Sensor Cable into the strain relief slot in the Control Module.

Install Circuit Board Cover into Control Module.

IMPORTANT NOTES

DO NOT INSTALL THE BATTERIES UNTIL THE FAUCET IS COMPLETELY INSTALLED. If the batteries are installed before the sensor cable has been connected to the control module, the faucet will not properly set the sensing range for the sink on which it has been installed.

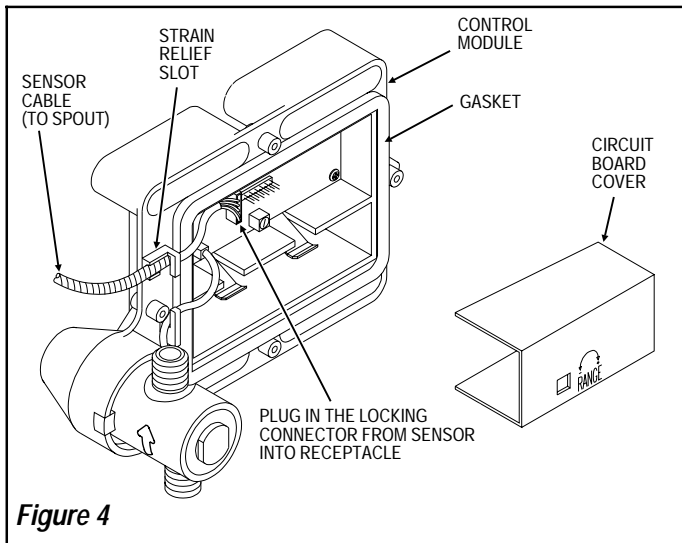

Figure 4

Step 5 — Connect Supply Line From Solenoid Valve Outlet to Faucet (Figures 5A and 5B)

Note: An arrow on the body of the Solenoid Valve indicates the water flow direction.

Important: Keep thread sealant out of your waterway and prevent component part damage! Do not use sealant on compression fittings. When thread sealant is used, do not apply it to the first two "starter" threads.

For Model 615 — Install the 1/4 inch Pipe to 3/8 inch Tube Compression Fitting onto the Spout's Pipe Nipple (refer to Figure 5A).

For Model 650 — Install the 1/8 inch Pipe to 3/8 inch Tube Compression Fitting onto the Spout's Pipe Nipple (refer to Figure 5B).

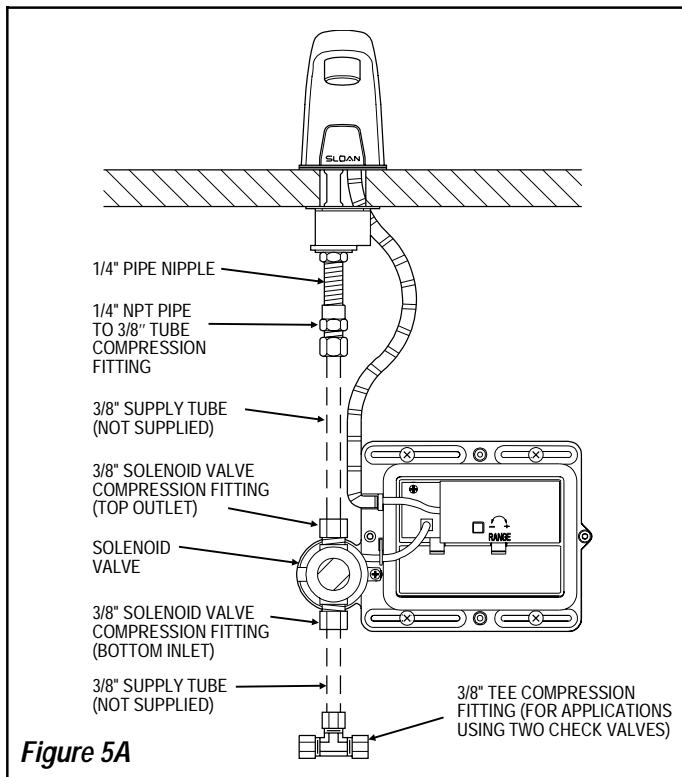

Figure 5A

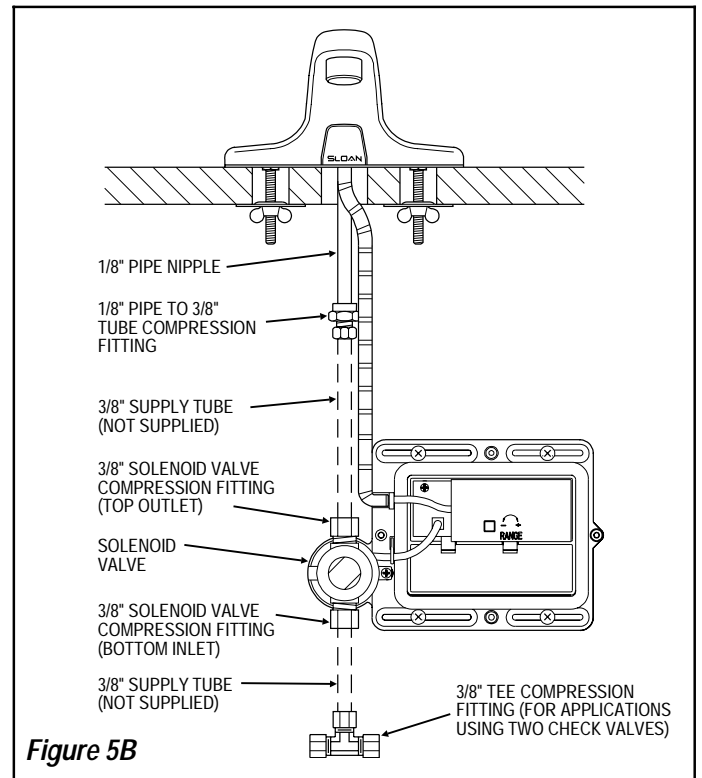

Figure 5B

For Models 615 and 650 — Connect 3/8 inch O.D. supply tube (furnished by installer) between the Compression Fitting on the Spout's Pipe Nipple and the top outlet Compression Fitting on the Solenoid Valve.

Step 6 — Connect Supply Line(s) From Supply Stop to Solenoid Valve Inlet (Refer to Figures A and B)

Note: Supply Stops should be furnished by installer.

Flush dirt, debris, and sediment from the supply line(s).

FOR DUAL LINE HOT AND COLD WATER SUPPLY APPLICATIONS

When connecting the Faucet to a hot and cold water supply, two Back Checks are required as described in Step 1. If Back Checks are not installed at this time, install them now referring back to Step 1 for instructions.

Install a 3/8 inch copper Supply Tube between each Back Check and the Compression Tee Fitting supplied (refer to Figure A or B).

Install a 3/8 inch copper Supply Tube between Compression Tee Fitting and the bottom inlet Compression Fitting of Solenoid Valve.

FOR SINGLE LINE WATER SUPPLY APPLICATIONS

When connecting the Faucet to a single line water supply or a pre-tempered water supply, no Back Check is required.

Install a 3/8" copper Supply Tube between the Supply Stop and the bottom inlet Compression Fitting of Solenoid Valve. (Refer to Figure A or B.)

Step 7 — Install Batteries (Figure 6)

Remove the Battery Compartment from the Control Module by gently pulling straight out. Spread the ends of the Battery Retainer and remove it from the Battery Compartment. Insert the four (4) "C" Cell Alkaline Batteries provided as indicated by the (+) and (-) symbols inside the Battery Compartment. Spread the ends of the Battery Retainer and slide it over the Battery Compartment until locked into place. **Note:** Battery Retainer must be installed as shown in Figure 6. If installed up-side-down, it will not install into the Control Module. Reinsert the Battery Compartment into the Control Module as shown in Figure 6.

IMPORTANT NOTES

DO NOT INSTALL THE BATTERIES UNTIL THE FAUCET IS COMPLETELY INSTALLED. If the batteries are installed before the sensor cable has been connected to the control module, the faucet will not properly set the sensing range for the sink on which it has been installed.

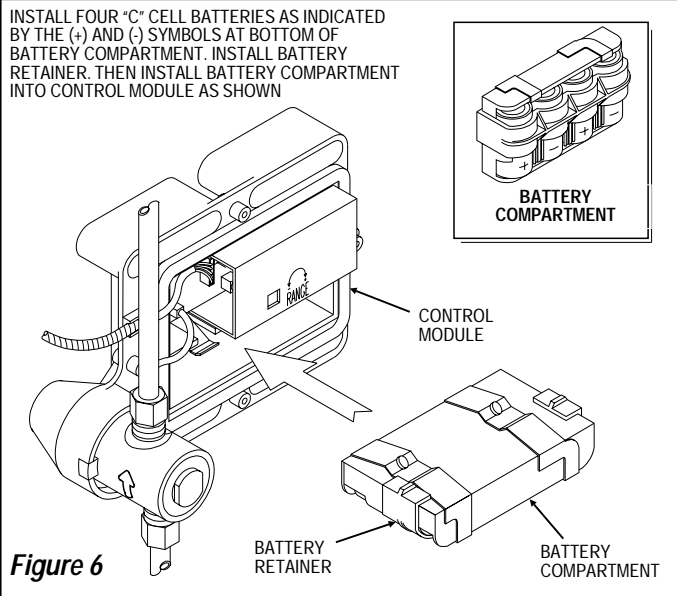

Step 8 — Start-Up

Open Supply Stops. Remove Spray Head, then activate Faucet for 30 seconds by placing hands in front of the Sensor. The Solenoid Valve should "click," Sensor LED indicator should blink and water should flow from the Spout. If this does not occur, refer to the Troubleshooting section of this instruction manual.

Note: The Sensor LED indicator should blink when Faucet is activated for the first 10 minutes after start-up.

Close Supply Stop(s) and install Spray Head in Spout using the Key provided. Reopen Supply Stop(s), activate Faucet and check for leaks.

Step 9 – Range Adjustment (Figure 7)

The OPTIMA Plus EBF-615 and EBF-650 Faucets are factory set to operate when hands are placed 4 to 5 inches (102 to 127 mm) from Sensor. This range should be satisfactory for most installations.

If range adjustment is required, use a small Phillips screwdriver.

ADJUST RANGE

The Range Potentiometer is located in the Control Module shown in Figure 7.

Important: Range Potentiometer adjustment screw rotates only 3/4 of a turn; DO NOT over-rotate.

The EBF-615 and EBF-650 Faucets are factory set to operate when hands are placed 4 to 5 inches (102 mm to 127 mm) from the sensor. If further adjustment is required, turn Range Potentiometer counterclockwise to decrease range or clockwise to increase range.

Cycle Faucet several times to assure that the Sensor range does not inadvertently pick up reflection off the edge of the sink. If reflection occurs, slightly adjust Range Potentiometer counterclockwise and again cycle Faucet.

Repeat adjustment procedure until desired range is achieved.

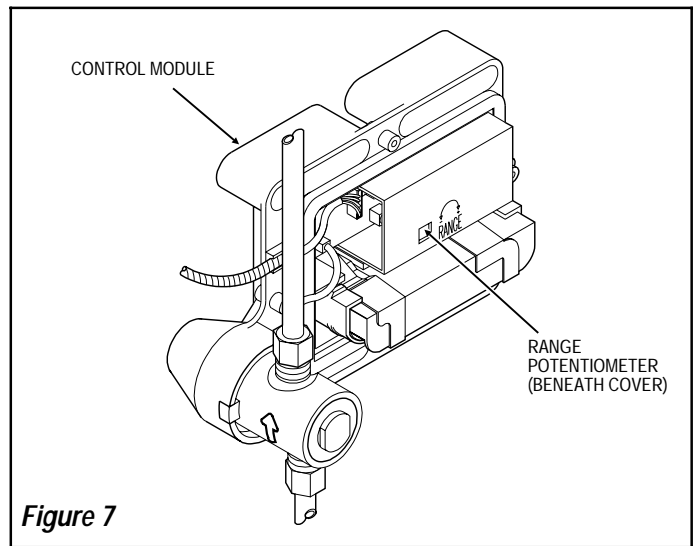

Step 10 — Install Cover to Control Module (Figure 8)

Place Cover over the Control Module and use the four (4) screws provided to attach it. Cover can be installed in only one orientation.

Important: Install all four (4) Cover Screws for proper installation.

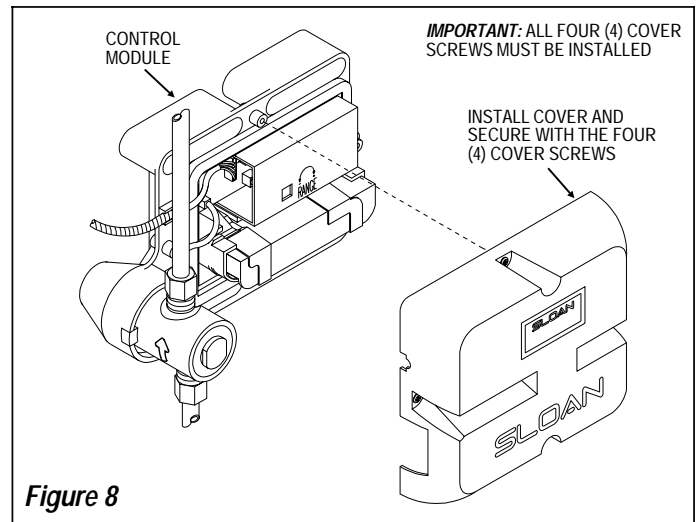

IMPORTANT NOTES

DO NOT INSTALL THE BATTERIES UNTIL THE FAUCET IS COMPLETELY INSTALLED. If the batteries are installed before the sensor cable has been connected to the control module, the faucet will not properly set the sensing range for the sink on which it has been installed.

OPERATION

1. A continuous invisible beam of infrared light is emitted from the sensor located on the throat of the lavatory faucet.

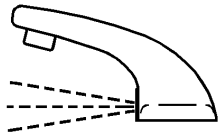

2. As the user's hands enter the beam's effective range (beneath the spray head), the beam is reflected back into the sensor receiver and activates the solenoid valve. Tempered water flows from the faucet into the sink until the hands are removed from the beam or until the faucet reaches an automatic time out limit setting.

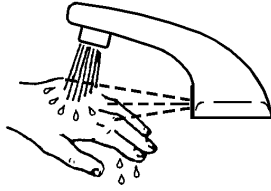

3. When hands are moved away from the sensor, the loss of reflected light initiates an electrical signal that deactivates the solenoid valve, shutting off the water flow. The circuit then automatically resets and is ready for the next user.

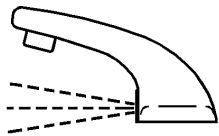

CARE AND CLEANING OF CHROME AND SPECIAL FINISHES

DO NOT use abrasive or chemical cleaners (including chlorine bleach) to clean faucets that may dull the luster and attack the chrome or special decorative finishes. Use ONLY soap and water, then wipe dry with clean cloth or towel.

Protect the faucet from any splattering of cleaner when cleaning bathroom tile. Acids and cleaning fluids will discolor or remove chrome plating.

IMPORTANT NOTES

DO NOT INSTALL THE BATTERIES UNTIL THE FAUCET IS COMPLETELY INSTALLED. If the batteries are installed before the sensor cable has been connected to the control module, the faucet will not properly set the sensing range for the sink on which it has been installed.

TROUBLESHOOTING GUIDE

1. **PROBLEM:** Sensor troubleshooting LED does not function (red indicator light does not flash during set-up procedure).

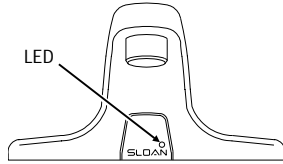

- CAUSE:** No battery power is being supplied to Sensor.
- SOLUTION:** Ensure that the batteries are installed properly. Check that the orientation of each battery matches the positive (+) and negative (-) symbols shown on the bottom of the battery compartment. Reinsert the Battery Compartment into the Control Module.
- CAUSE:** Insufficient battery power is being supplied to sensor.
- SOLUTION:** One (or more) of the batteries is "dead." To ensure proper operation, insert four (4) new C-size Alkaline batteries. Check that the orientation of each battery matches the positive (+) and negative (-) symbols shown on the bottom of the Battery Compartment. Reinsert the Battery Compartment into the Control Module.
- CAUSE:** Sensor Cable is not properly inserted.
- SOLUTION:** Disconnect and reconnect Sensor Cable to the Control Module.
- CAUSE:** Sensor range is set at minimum distance.
- SOLUTION:** Increase Sensor range. Use a small screwdriver to turn the potentiometer screw (white screw in a blue base) clockwise.
- CAUSE:** Control Module assembly is defective.
- SOLUTION:** Replace EBF-60-A Control Module assembly.
2. **PROBLEM:** Faucet does not deliver any water when Sensor is activated.
- INDICATOR:** Solenoid valve produces audible "CLICK."
- CAUSE:** Water supply valve is closed.
- SOLUTION:** Open the Supply Stop.
- INDICATOR:** Solenoid valve DOES NOT produce an audible "CLICK."
- CAUSE:** Solenoid lead is not properly connected to the Control Module.
- SOLUTION:** Disconnect and reconnect Solenoid lead to the Control Module.
- CAUSE:** Batteries are not installed properly.
- SOLUTION:** Check that the orientation of each battery matches the positive (+) and negative (-) symbols shown on the bottom of the battery compartment. Reinsert the Battery Compartment into the Control Module. The troubleshooting LED should flash RED when a user is detected.

3. **PROBLEM:** Faucet delivers only a slow flow or dribble when Sensor is activated.
- CAUSE:** Water supply valve is partially closed.
- SOLUTION:** Completely open the Supply Stop.
- CAUSE:** Solenoid Filter is clogged.
- SOLUTION:** Remove, clean, and reinsert. Replace EBF-1004-A Solenoid Filter Kit if necessary.
- CAUSE:** Aerator or Spray head is clogged.
- SOLUTION:** Remove, clean, and reinsert.
4. **PROBLEM:** Faucet does not stop delivering water or continues to drip after user is no longer detected (automatic shut-off fails even when batteries are removed).
- CAUSE:** Solenoid Valve has been connected backwards.
- SOLUTION:** Disassemble Solenoid Valve compression fittings at both the inlet and outlet positions. The water should flow from inlet through the Solenoid Valve to the outlet according to the direction of the arrow shown on the side of the Solenoid Valve. Reconnect the compression fittings in the correct orientation.
- CAUSE:** Solenoid Valve is dirty.
- SOLUTION:** Backflush by reversing water flow (opposite to the direction shown by the arrow on the side of the Solenoid Valve) through the Solenoid Valve. Reconnect the compression fittings in the correct orientation. Activate faucet.
- CAUSE:** Solenoid Valve Module is defective.
- SOLUTION:** Replace EBF-62-A Solenoid Valve Module.
5. **PROBLEM:** The water temperature is too hot or too cold on a faucet connected to hot and cold supply lines with two Back Checks.
- CAUSE:** Supply Stops are not adjusted properly.
- SOLUTION:** Adjust Supply Stops.
- CAUSE:** One Back Check is installed backwards.
- SOLUTION:** Reinstall Back Check.
- NOTE:** For some systems, a thermostatic mixing valve may be required.

If further assistance is required, please contact the Sloan Valve Company Installation Engineering Department at 1-888-SLOAN-14.

IMPORTANT NOTES

DO NOT INSTALL THE BATTERIES UNTIL THE FAUCET IS COMPLETELY INSTALLED. If the batteries are installed before the sensor cable has been connected to the control module, the faucet will not properly set the sensing range for the sink on which it has been installed.

BATTERY REPLACEMENT PROCEDURE (Water does not need to be turned off)

The Sloan Optima Plus EBF-615 and EBF-650 Battery Powered, Sensor Operated Lavatory faucets are furnished with (4) "C" cell alkaline batteries that provide up to two (2) years of operation (8000 cycles per month). A flashing LED signal indicates that battery power will be depleted within one (1) month. Replace batteries with four (4) new "C" cell alkaline batteries.

Remove the Cover of the Control Module by unscrewing the four (4) Cover Screws located at the center of each side.

Remove the Battery Compartment from the Control Module by gently pulling straight out with a firm grip. Spread the ends of the Battery Retainer and remove it from the Battery Compartment. Remove the old batteries and insert four (4) fresh "C" cell alkaline batteries into the Battery Compartment as indicated by the (+) and (-) symbols inside the Battery Compartment. Spread the ends of the Battery Retainer and slide it over the Battery Compartment until locked into place.

Note: Battery Retainer must be installed as shown in Figure 9. If installed up-side-down, it will not install into the Control Module. Reinsert the Battery Compartment into the Control Module as shown in Figure 9.

Place Cover over the Control Module and use the four (4) screws provided to attach it. Cover can be installed in only one orientation.

Important: Install all four (4) Cover Screws for proper installation.

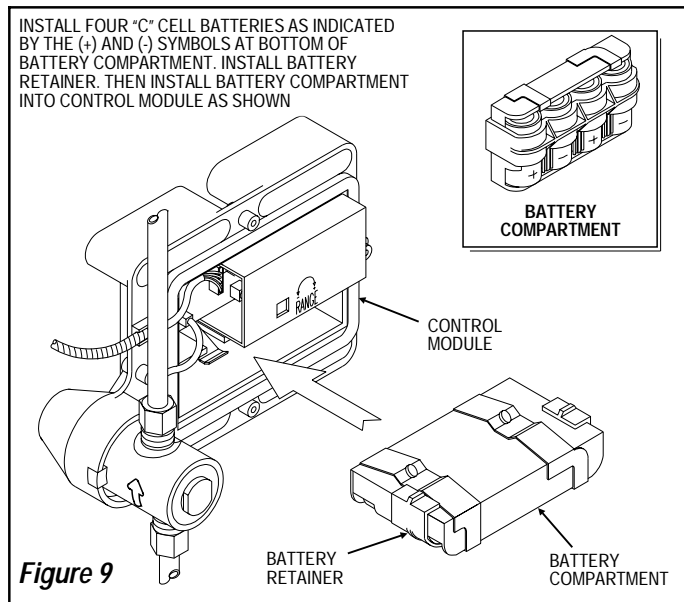

CLEANING OF SCREEN FILTER (Figure 10)

Before cleaning the Screen Filter, turn off the water supply at the supply stop(s). Activate the faucet to relieve any pressure in the system. Unscrew the Filter Plug and remove it from the Solenoid Valve Housing. Carefully pull the Screen Filter with attached rubber seals out from the Solenoid Valve Housing.

Clean the Screen Filter using fresh tap water only. If necessary, use a small brush to clean. Use caution while cleaning to prevent damage to the Solenoid Screen Filter. If any Filter components are damaged, order Filter Replacement Kit EBF-1004-A.

Carefully replace the Screen Filter into the groove of the Solenoid Valve Housing. Examine the Filter Plug O-Ring for wear or damage; replace if necessary. If necessary, lubricate the Filter Plug O-Ring with water to keep it in place in the groove of the Filter Plug. Screw the Filter Plug into the Solenoid Valve Housing.

Turn on the water supply at the supply stop(s). Activate the faucet to purge any air from the system lines. Check for leaks and repair as necessary.

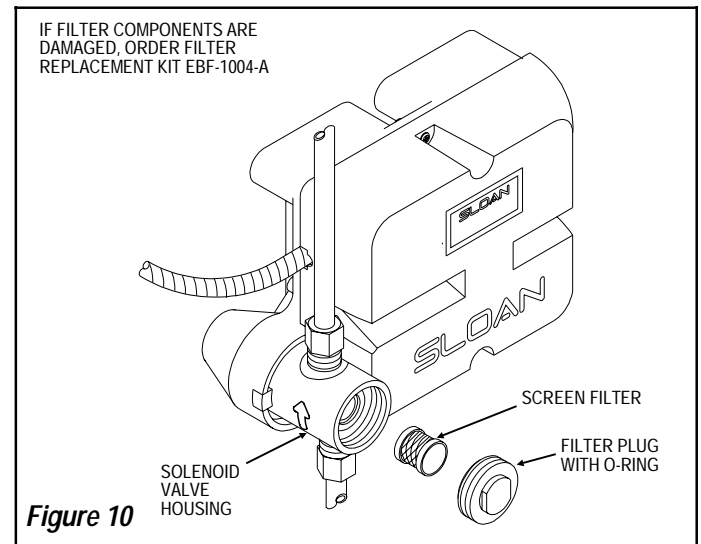

IMPORTANT NOTES

DO NOT INSTALL THE BATTERIES UNTIL THE FAUCET IS COMPLETELY INSTALLED. If the batteries are installed before the sensor cable has been connected to the control module, the faucet will not properly set the sensing range for the sink on which it has been installed.

PARTS LIST

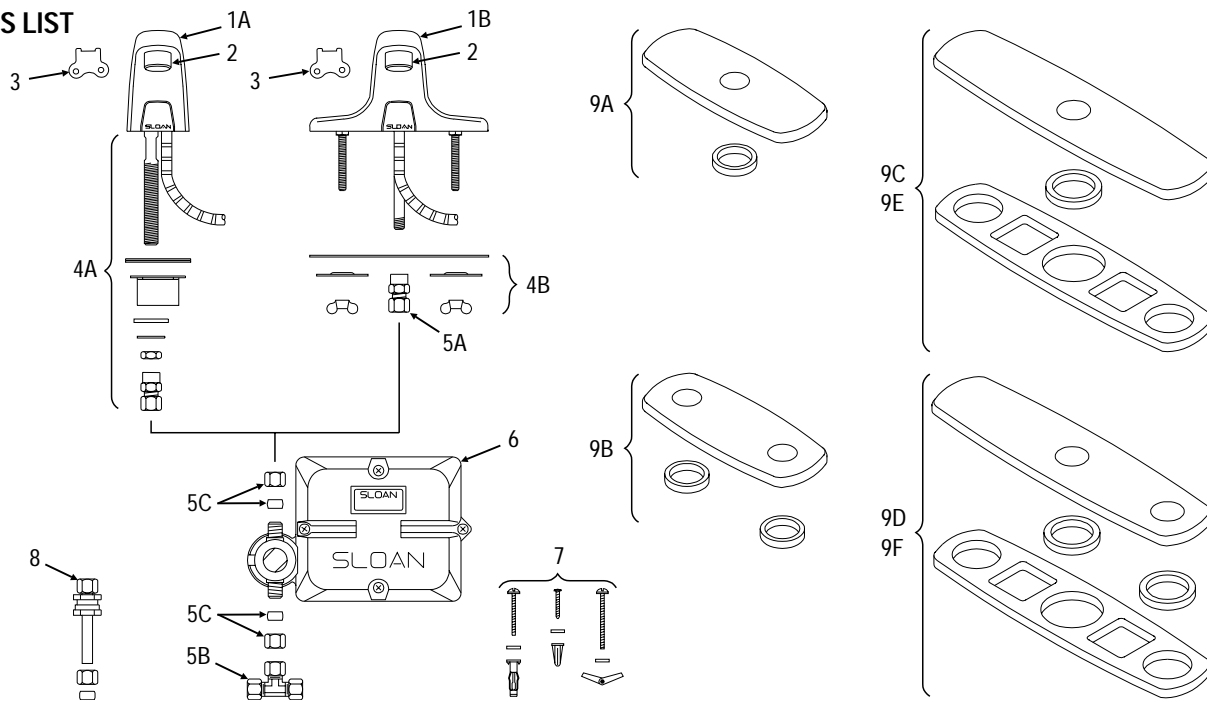

Item No.	Part No.	Description
1A	EBF-120-A	Pedestal Faucet Spout and Sensor Assembly (EBF-615)
1B	EBF-81-A	Faucet Spout and Sensor Assembly (EBF-650)
2	ETF-1023-A	0.5 gpm (1.9 Lpm) Spray Head with Key (male thread)
	ETF-1024-A	2.2 gpm (8.3 Lpm) Aerator Spray Head with Key (male thread)
	F-175-L	2.2 gpm (8.3 Lpm) Laminar Flow Spray Head (male thread)
3	ETF-435	Replacement Key Only for ETF-1023-A 0.5 gpm (1.9 Lpm) Spray Head and ETF-1024-A 2.2 gpm (8.3 Lpm) Aerator Spray Head (NOT required for F-175-L 2.2 gpm/8.3 Lpm Laminar Flow Spray Head)
4A	EBF-123-A	Faucet Mounting Kit for EBF-615 includes 3/8" RB Water Supply Tube, Base Gasket, Spacer, Washer, 9/16" Lockwasher, 1/4" NPSM Hex Nut, and ETF-547 Compression Fitting Connector
4B	ETF-546-A	Faucet Mounting Kit for EBF-650 includes Base Gasket, two (2) Slotted Mounting Washers, two (2) Wing Nuts, and ETF-547 Compression Fitting Connector
5A	ETF-547	1/8" NPT Pipe to 3/8" Tube Compression Fitting Connector (female)
5B	ETF-259	3/8" Tee Compression Fitting
5C	EBF-113-A	Single Solenoid Supply Kit includes two (2) Compression Nuts, two (2) Compression Sleeves, and Screwdriver (Not shown)
6	EBF-60-A	Control Module Assembly includes Base Enclosure, Cover Enclosure, two (2) Gaskets, Solenoid Body, Solenoid Enclosure, Solenoid Filter Plug and Battery Stop
7	EBF-79-A	Mounting Hardware Kit for Control Module Assembly includes four (4) Anchor Nuts, four (4) Toggle Nuts, four (4) Mounting Screws for Base Plate, four (4) Flat Washers, four (4) Anchors, and four (4) Metal Screws
8	ETF-470-A	Back Check
9A	ETF-103-A	4" (102 mm) Centerset Single-hole Trim Plate Kit for EBF-615 Faucet (Faucet only)
9B	MIX-102-A	4" (102 mm) Centerset Double-hole Trim Plate Kit for EBF-615 Faucet with Optional Mixing Valve
9C	ETF-105-A	8" (204 mm) Centerset Single-hole Trim Plate Kit for EBF-615 Faucet (Faucet only)
9D	MIX-102-A	8" (204 mm) Centerset Double-hole Trim Plate Kit for EBF-615 Faucet with Optional Mixing Valve
9E	ETF-576-A	8" (204 mm) Centerset Single-hole Trim Plate Kit for EBF-650 Faucet (Faucet only)
9F	ETF-577-A	8" (204 mm) Centerset Double-hole Trim Plate Kit for EBF-650 Faucet with Optional Mixing Valve
—	EBF-80-A	Sensor Replacement Kit includes Cable Assembly, Retainer for PC Board Assembly, and Housing for Sensor Window
—	EBF-62-A	Solenoid Replacement Kit includes Solenoid Body, Solenoid Enclosure, and Solenoid Filter Plug
—	EBF-1004-A	Solenoid Filter Replacement Kit includes Filter Screen Assembly and O-Ring
—	EBF-1006-A	Repair Kit for EBF-60-A Control Module Assembly includes EBF-61-A Battery Holder Assembly and EBF-159 Battery Gasket
—	EBF-50	Control Module Replacement Gasket (two required)
—	EBF-1007-A	Faucet Cable Assembly Repair Kit for EBF-650 includes Sensor Window Housing Assembly and Bracket for Sensor Window

NOTICE

The information contained in this document is subject to change without notice.

SLOAN
Copyright © 2000 Sloan Valve Company

SLOAN VALVE COMPANY • 10500 Seymour Avenue • Franklin Park, IL 60131
Phone: 1-800-9-VALVE-9 or 1-847-671-4300 • Fax: 1-800-447-8329 or 1-847-671-4380
<http://www.sloanvalve.com>
Printed in U.S.A. 06-00