

113-SMO

113-1.6-SMO

► **Description**

Exposed, Battery Powered, Side Mount Sensor Operated Water Closet Flushometer for floor mounted or wall hung top spud bowls.

► **Flush Cycle**

- Model 113-SMO Water Saver (3.5 gpf/13.2 Lpf)
- Model 113-1.6-SMO Low Consumption (1.6 gpf/6.0 Lpf)

► **Specifications**

Quiet, Exposed, Diaphragm Type, Chrome Plated Closet Flushometer for either left or right hand supply with the following features:

- ADA Compliant OPTIMA[®] Battery Powered Infrared Sensor for automatic "No Hands" operation
- Chrome Plated Infrared Sensor Housing
- Angled Sensor Window
- Manual Override Flush Button
- Four (4) Size C Batteries included
- "Low Battery" Flashing LED with Optional Audio Tone
- "User in View" Flashing LED
- Optional 24 Hour Sentinel Flush
- Infrared Sensor Range Adjustment Screw and Reset Button
- 1" I.P.S. Screwdriver Bak-Chek[™] Angle Stop
- Vandal Resistant Stop Cap
- Adjustable Tailpiece
- Vacuum Breaker Flush Connection
- Spud Coupling, Wall and Spud Flanges for 1½" Top Spud
- High Copper, Low Zinc Brass Castings for Dezincification Resistance
- Low Consumption Flush Accuracy Controlled by Para-Flo[™] Technology
- No External Volume Adjustment to Ensure Water Conservation
- Stop Seat and Vacuum Breaker to be molded from PERMEX[™] Rubber Compound for Chloramine resistance

Valve Body, Tailpiece and Control Stop shall be in conformance with ASTM Alloy Classification for Semi-Red Brass. Valve shall be in compliance with the applicable sections of ASSE 1037, ANSI/ASME A112.19.2 and Military Specification V-29193. Installation conforms to ADA requirements.

► **Variations**

- TP** Trap Primer
- YB** Sweat Solder Adapter Kit with Stamped Flange
- YBYC** Sweat Solder Adapter & Cast Wall Flange w/Set Screw

XL Regal Optima SMO XL

Flushometer includes Vandal Resistant Stop Cap with Set Screw, and Sweat Solder Adapter with Cover Tube and Cast Set Screw Wall Flange.

See Accessories Section and OPTIMA Accessories Section of the Sloan catalog for details on these and other OPTIMA[®] Flushometer variations.



► **ADA Compliant**

► **Automatic**

Sloan OPTIMA SMO equipped Flushometers provide the ultimate in sanitary protection and automatic operation. There is no need for AC hookups or wall alterations. The Flushometer operates by means of a battery powered infrared sensor. Once the user enters the sensor's effective range and then steps away, the Side Mount Unit initiates the flushing cycle to flush the fixture.

► **Hygienic**

User makes no physical contact with the Flushometer surface except to initiate the Override Button when required. Helps control the spread of infectious diseases. 24 Hour Sentinel Flush keeps fixture fresh during periods of nonuse.

► **Economical**

Automatic operation provides water usage savings over other flushing devices. Reduces maintenance and operation costs. Installation and battery replacement does not require turning off water to the valve.

► **Warranty**

3 year (limited)



This space for Architect/Engineer approval

Job Name _____ Date _____

Model Specified _____ Quantity _____

Variations Specified _____

Customer/Wholesaler _____

Contractor _____

Architect _____

113-SMO 113-1.6-SMO

► Description

Exposed, Battery Powered, Side Mount Sensor Operated Water Closet Flushometer for floor mounted or wall hung top spud bowls.

► Flush Cycle

- Model 113-SMO Water Saver (3.5 gpf/13.2 Lpf)
- Model 113-1.6-SMO Low Consumption (1.6 gpf/6.0 Lpf)

ELECTRICAL SPECIFICATIONS

- **Control Circuit**
Solid State
6 VDC Input
- **OPTIMA Sensor Type**
Infrared Convergence Type
Object Lock Detection
- **OPTIMA Sensor Range**
Nominal 8" - 54" (203 mm - 1372 mm), Factory Set at 24" (610 mm)
- **Battery Type**
(4) Size C Alkaline
- **Battery Life**
2 Years @ 3,000
Flushes/Month
- **Indicator Lights**
User in View/Low Battery
- **Operating Pressure**
15-100 psi (104-689 kPa)
- **Operation Features**
(can be turned on and off)
24 Hour Sentinel Flush
Audio Low Battery Tone

VISUAL INDICATOR GUIDE

USER-IN-VIEW L.E.D. — Green light flashes 3 times after 5 second delay when a user is in view. The green light flashes constantly when a user is in view during the 7 minute start up sequence.

BATTERY L.E.D. — Yellow light flashes indicating it is time to replace batteries with four (4) new Type "C" batteries.

OBJECT LOCK SENSOR — Detects user or object.

COURTESY MANUAL FLUSH BUTTON — Allows manual activation of flush when needed.

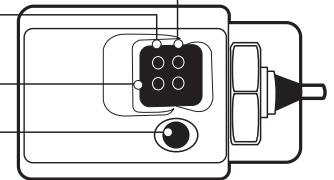

OPERATION

1. A continuous, invisible light beam is emitted from the Object Lock Infrared Sensor.

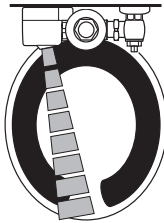

2. As the user enters the beam's effective range, 8" to 54" (203 mm - 1372 mm), the Object Lock Infrared Sensor senses the user.

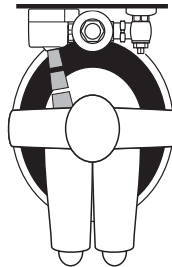

3. When the user steps away from the Object Lock Infrared Sensor, the circuit initiates the flushing cycle to flush the fixture. The Circuit then automatically resets and is ready for the next user.

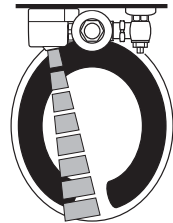

ROUGH-IN

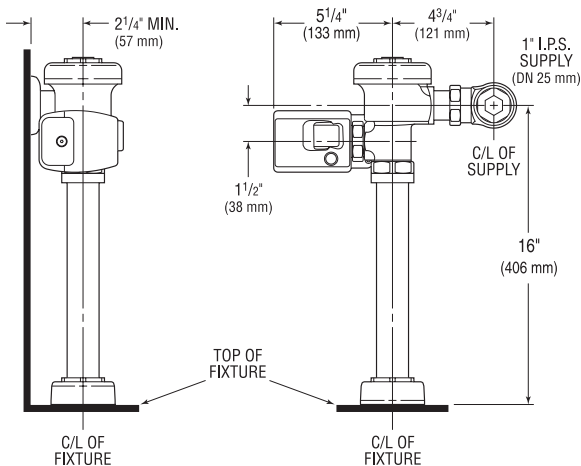

Includes EBV-89-A Side Mount Operator

FUNCTION SETTINGS

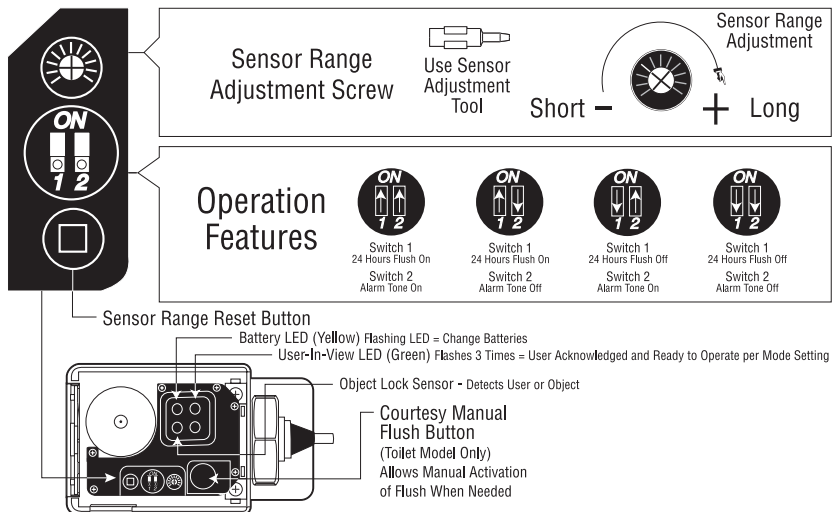

SLOAN VALVE COMPANY • 10500 SEYMOUR AVENUE • FRANKLIN PARK, IL 60131

Phone: 1-800-9-VALVE-9 or 1-847-671-4300 • Fax: 1-800-447-8329 or 1-847-671-4380 • <http://www.sloanvalve.com>